

# Parts Manual for

# SNAPPER®

## 21" SERIES 2 & 4\* BLADE BRAKE CLUTCH WALK MOWERS

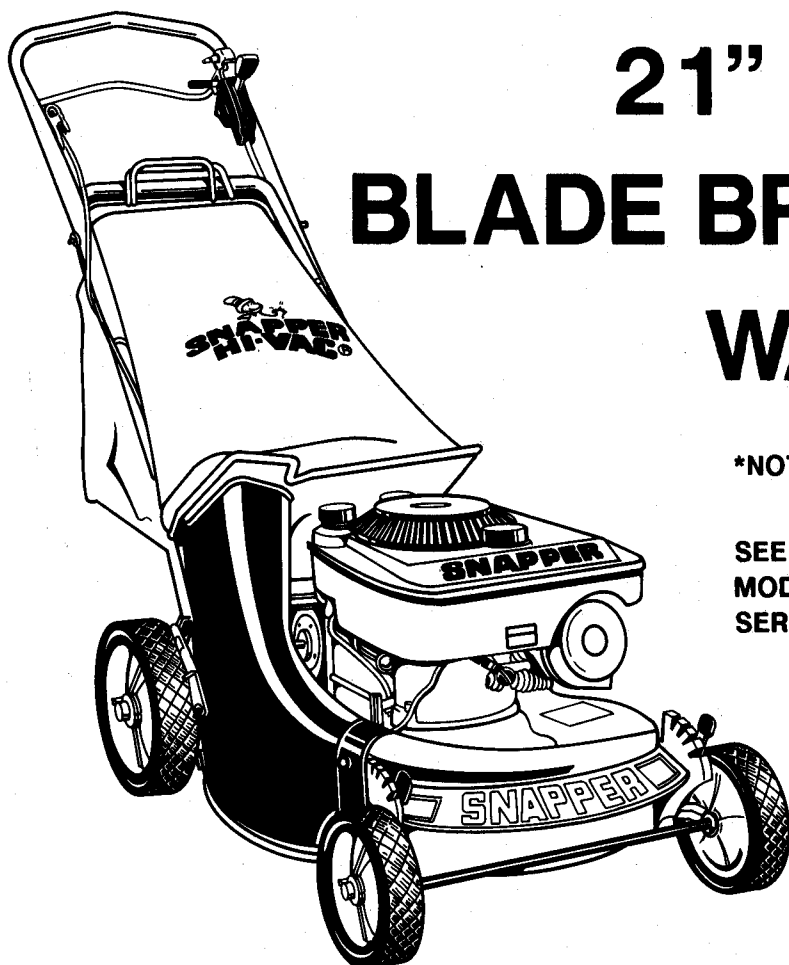

\*NOTE: THE SERIES NUMBER IS THE LAST NUMBER  
IN THE FIVE DIGIT MODEL DESIGNATION.

SEE PARTS MANUAL 06041 FOR 21" SERIES 1 & 5  
MODELS OR MANUAL 06141 FOR 21" COMMERCIAL  
SERIES 0 PARTS.

### PARTS GROUP INDEX

INDEX - GROUP	(SECTION)	PAGE(S)
HANDLES, CONTROLS	(ONE)	1.1 - 1.5
SIDE CHUTES, GRASS CATCHERS	(TWO)	2.1
CUTTING DECK, BLADES	(THREE)	3.1 - 3.2
DRIVE SYSTEM-SELF PROPELLED	(FOUR)	4.1 - 4.4
WHEELS, BRACKETS, LATCHES	(FIVE)	5.1 - 5.3
ACCESSORIES *	(SIX)	6.1 - 6.6
DECALS	(SIX)	6.2

\*PAC-N-SAC ACCESSORY COVERED IN PARTS MANUAL 06121

**SNAPPER POWER EQUIPMENT**

McDonough, GA • 30253



(REVISION 12/88)

(REPLACES 10/86)

**MANUAL #06131**

HANDLES & CONTROLS (SERIES 2) (SEE PAGES 1.3 & 1.4 FOR SERIES 4)

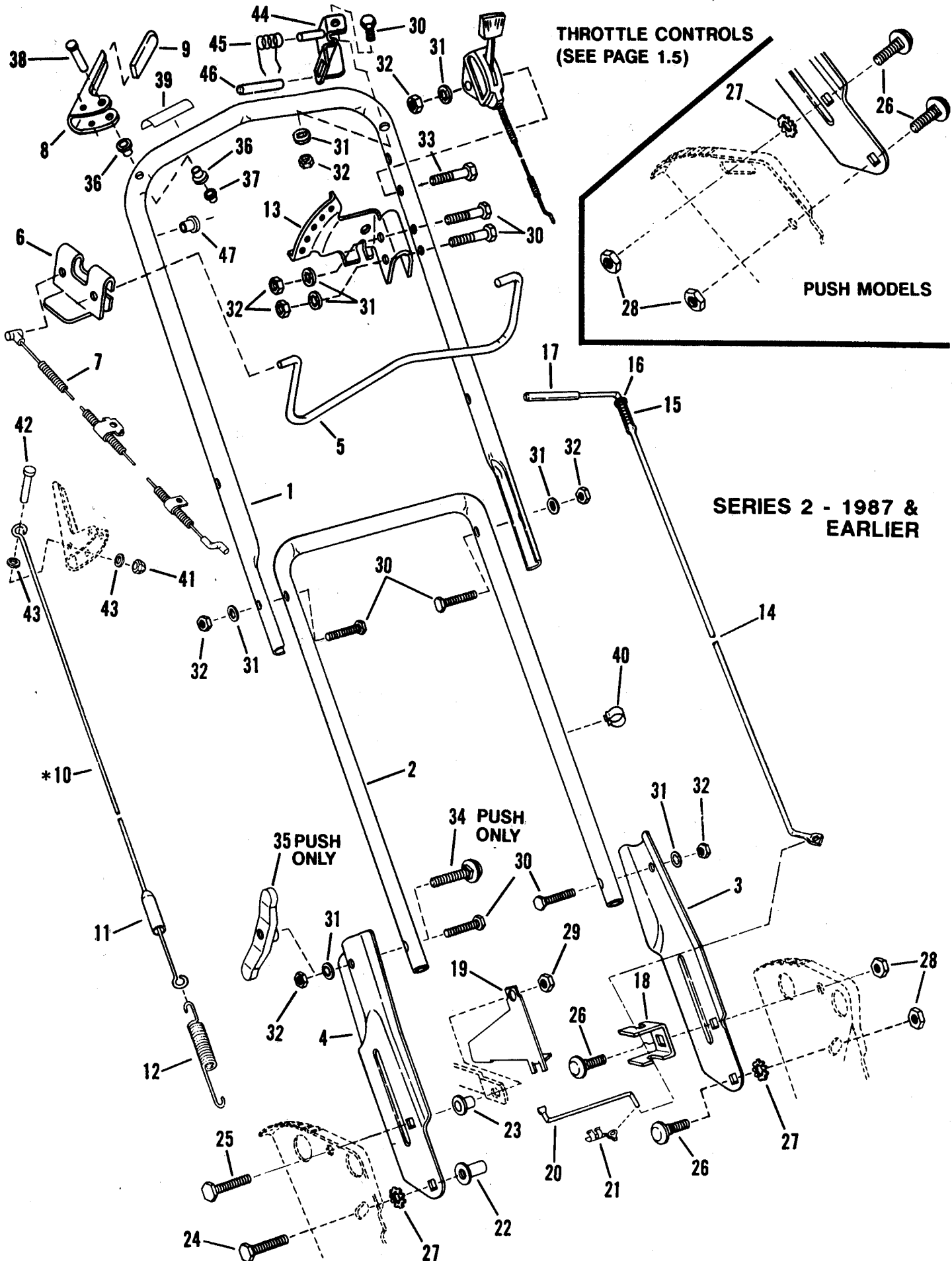

ITEM	PART NO.	DESCRIPTION	(USED ON)
1	3-6143	HANDLE, Upper	Push Models
-	3-6141	HANDLE, Upper	Self-Propelled
2	3-6037	HANDLE, Middle	All
3	3-8247	HANDLE, Lower L.H.	All
4	3-8246	HANDLE, Lower R.H.	All
5	1-9762	CONTROL, Blade	All
6	3-2445	CLIP, Blade Control	All
7	1-8841	CABLE, Clutch Control	All
8	3-2237	HANDLE, Wheel Drive	Self-propelled
9	1-4307	GRIP, Handle	Self-propelled
10	5-1672	CABLE, Clutch Pull	Self-propelled
-	2-3134	CABLE, Clutch Pull ('89 Models & Later)	Self-propelled
11	1-2121	COVER, Vinyl	Self-prop.(part of item 10)
12	1-2122	SPRING, Clutch	Self-propelled
13	3-7727	SECTOR, Speed	Self-propelled
14	1-2110	LEVER, Speed Control	Self-propelled
15	1-2093	SPRING, Speed Control	Self-propelled
16	9-0188	WASHER, 3/8 Flat	All
17	1-1879	GRIP, Speed Contr. Handle	Self-propelled
18	3-1755	ANCHOR, Speed Contr.	Self-propelled
19	3-2408	GUIDE, Lower(V-Belt)	Self-propelled
20	1-2255	ROD, Transfer	Self-propelled
21	1-0937	CLIP, Transfer Rod	Self-propelled
22	9-0895	TEE-NUT, 5/16-18	Self-propelled
23	1-2114	BUSHING, Differential	Self-propelled
24	9-0595	BOLT, 5/16-18x1" Hex Flange Lock	Self-propelled
25	9-0238	CAPSCREW, 5/16-24x1	Self-propelled
26	9-0799	BOLT, 5/16x18x5/8 Carr.	All
27	9-0189	LOCKWASHER, 5/16 I.E.Tooth	All
28	9-0585	NUT, 5/16-18 Hex Flange Lock	All
29	9-0222	NUT, 5/16-24 Center Lock	Self-propelled
30	9-0552	CAPSCREW, 1/4-28x1-3/8	All
31	9-0053	LOCKWASHER, 1/4 Int.Tooth	All
32	9-0095	NUT, 1/4-28 Hex	All
33	9-0111	CAPSCREW, 1/4-28x1-3/4	All
34	9-0950	BOLT, 1/4-20x1-7/8" Carriage	Push
35	1-4207	WING-NUT, 1/4-20	Push
36	1-4343	BUSHING	All
37	9-0489	PUSH-NUT	All
38	1-1886	PIN, Clutch Handle	Self-propelled
39	1-4945	DECAL, Starting Procedure	All (See back page)
40	1-4374	CLIP, Cable/Wiring	All
41	1-4734	PUSH-NUT	Self-propelled
42	1-4733	PIN, 3/16x1-3/4" Clevis	Self-propelled
43	9-0010	WASHER, #10 Flat (2)	Self-propelled
44	5-1544	ASSEMBLY, Blade Control Bracket	All
45	1-5108	SPRING, Blade Control	All
46	1-4946	GRIP, Pivot	All
47	1-5092	BUSHING	All

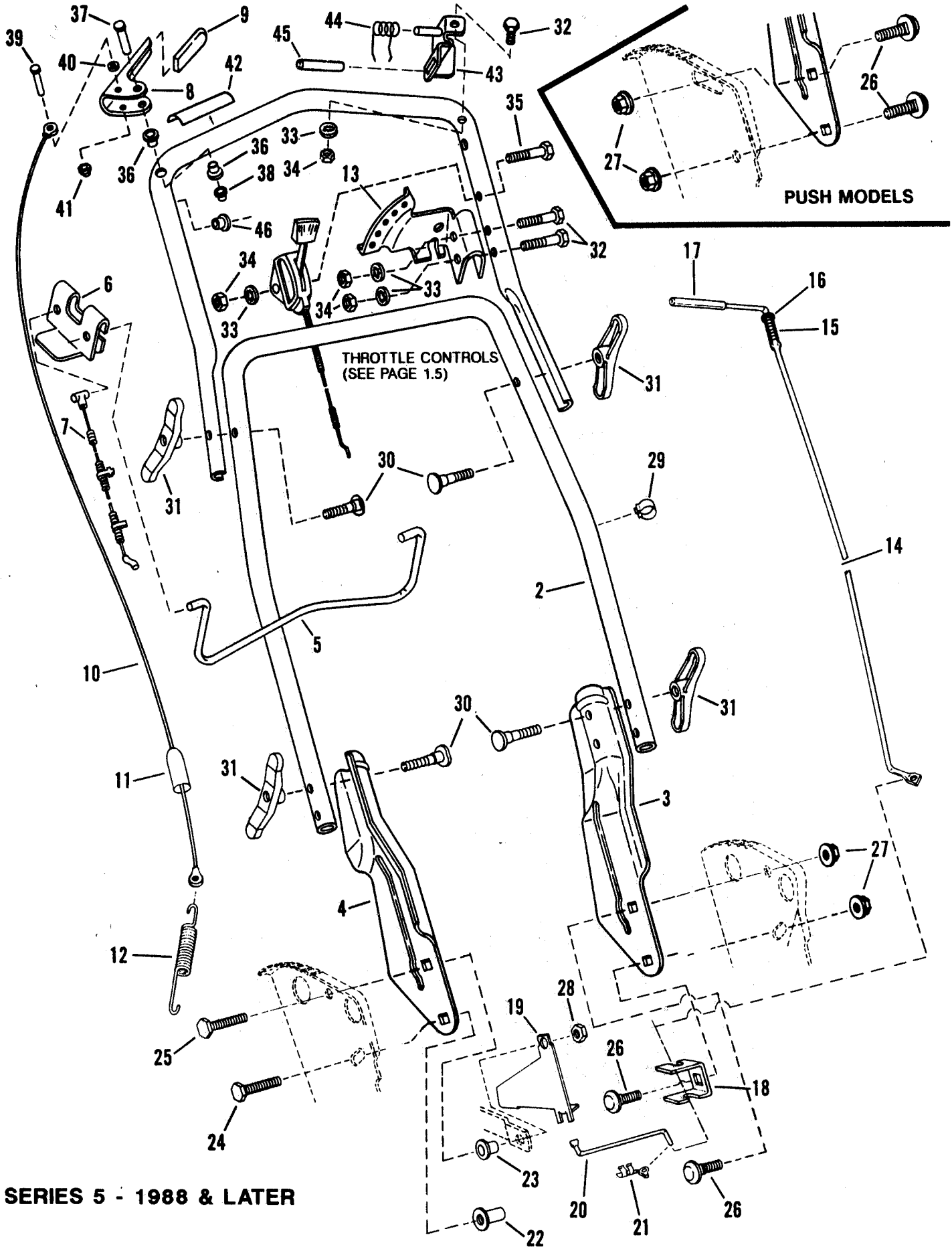

SERIES 5 - 1988 & LATER

MANUAL #06131 (REV.12/88)

1.3

21" BBC SERIES 2 & 4

# HANGLES & CONTROLS (SERIES 4)

ITEM	PART NO.	DESCRIPTION	(USED ON)
1	3-6203	HANDLE, Upper	Push
-	3-6204	HANDLE, Upper	Self-Propelled
2	3-6202	HANDLE, Middle	All
3	3-8401	HANDLE, Lower Left Hand	All
4	3-8402	HANDLE, Lower Right Hand	All
5	1-9762	CONTROL, Blade	All
6	3-2445	CLIP, Blade Control	All
7	1-8841	CABLE, Blade Control	All
8	3-2237	HANDLE, Wheel Drive	Self-propelled
9	1-4307	GRIP, Wheel Drive Handle	Self-propelled
10	5-1672	CABLE, Clutch Pull	Self-propelled (Incl. item 11)
-	2-3134	CABLE, Clutch Pull ('89 Models & Later)(Z-BEND)	Self-propelled
11	1-2121	COVER, Vinyl	Self-propelled (Part of item 10)
12	1-2122	SPRING, Clutch	Self-propelled
13	3-7727	SECTOR, Speed	Self-propelled
14	1-5695	LEVER, Speed Control (Replaces 1-2110)	Self-propelled
15	1-2093	SPRING, Speed Control	Self-propelled
16	9-0188	WASHER, 3/8 Flat	All-different locations
17	1-1879	GRIP, Speed Control Handle	Self-propelled
18	3-1755	ANCHOR, Speed Control	Self-propelled
19	3-2408	GUIDE, Lower V-Belt	Self-propelled
20	1-2255	ROD, Transfer	Self-propelled
21	1-0937	CLIP, Transfer Rod	Self-propelled
22	9-0895	TEE-NUT, 5/16-18	Self-propelled
23	1-2114	BUSHING, Differential	Self-propelled
24	9-0595	BOLT, 5/16-18x3/4 Flange Lock	Self-propelled
25	9-0238	CAPSCREW, 5/16-24x1	Self-propelled
26	9-0799	BOLT, 5/16-18x5/8 Carriage	All (different locations)
27	9-0585	NUT, 5/16-18 Hex Flange Lock	All (different locations)
28	9-0222	NUT, 5/16-24 Center Lock	Self-propelled
29	1-4374	CLIP Cable/Wiring	All
30	9-0965	SCREW, 1/4Cx1-7/8 Curved Head	All
31	1-5693	WING-NUT, 1/4C	All
32	9-0552	CAPSCREW, 1/4-28x1-3/8	Self-propelled
33	9-0053	LOCKWASHER, 1/4 Internal Tooth	All (different locations)
34	9-0095	NUT, 1/4-20 Hex	All (different locations)
35	9-0111	CAPSCREW, 1/4-28x1-3/4	All (throttle control)
36	1-4343	BUSHING	All
37	1-1886	PIN, Clutch Handle	Self-propelled
38	9-0489	PUSH-NUT (for handle pin)	Self-propelled
39	1-4733	PIN, 1-3/4 LG (Clutch cable)	Self-propelled
40	9-0010	WASHER, #10 Flat	Self-propelled
41	1-4734	PUSH-NUT (for clutch pin)	Self-propelled
42	1-4945	DECAL, Blade Control	All (see backpage)
43	5-1544	ASSEMBLY, Blade Control Bracket	All
44	1-5108	SPRING, Blade Control	All
45	1-4946	GRIP, Pivot	All
46	1-5092	BUSHING	All

# THROTTLE CONTROLS

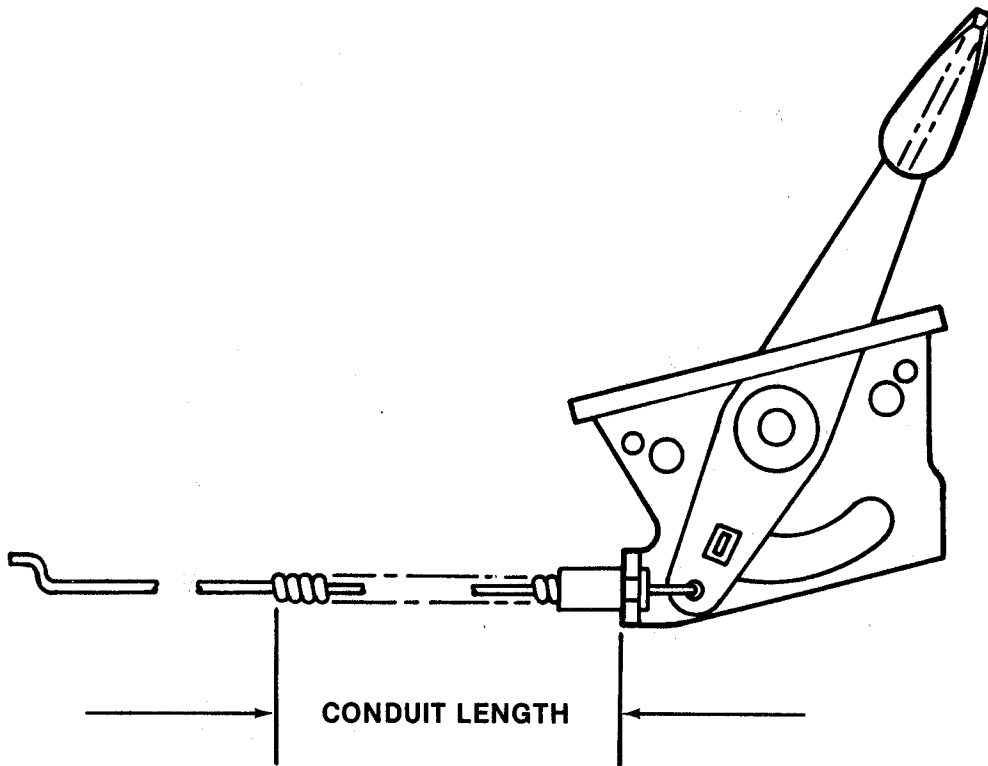

## THROTTLE CONTROLS SERIES 2

MOWER SERIES	ENGINE/MODEL	(Cycle)	PART NO.	CONDUIT LENGTH
21402 SERIES	BRIGGS 111702	(4)	1-8785	46.0"
21402P SERIES	BRIGGS 111702	(4)	1-8785	46.0"
214X2PR SERIES	ROBIN WI-145V	(4)	1-8839	40.75"
214X2PR-2 SERIES	ROBIN WTI-125V	(2)	1-8840	42.75"

## SERIES 4

MOWER SERIES	ENGINE/MODEL	(Cycle)	PART NO.	CONDUIT LENGTH
21404 SERIES	BRIGGS 111702	(4)	1-8785	46.0"
21404P SERIES	BRIGGS 111702	(4)	1-8785	46.0"
214X4PR SERIES	ROBIN WI-145V	(4)	1-8839	40.75"
214X4PR-2 SERIES	ROBIN WTI-125V	(2)	1-8840	42.75"

# SIDE CHUTE, ADAPTER

① (KIT, Side Chute)

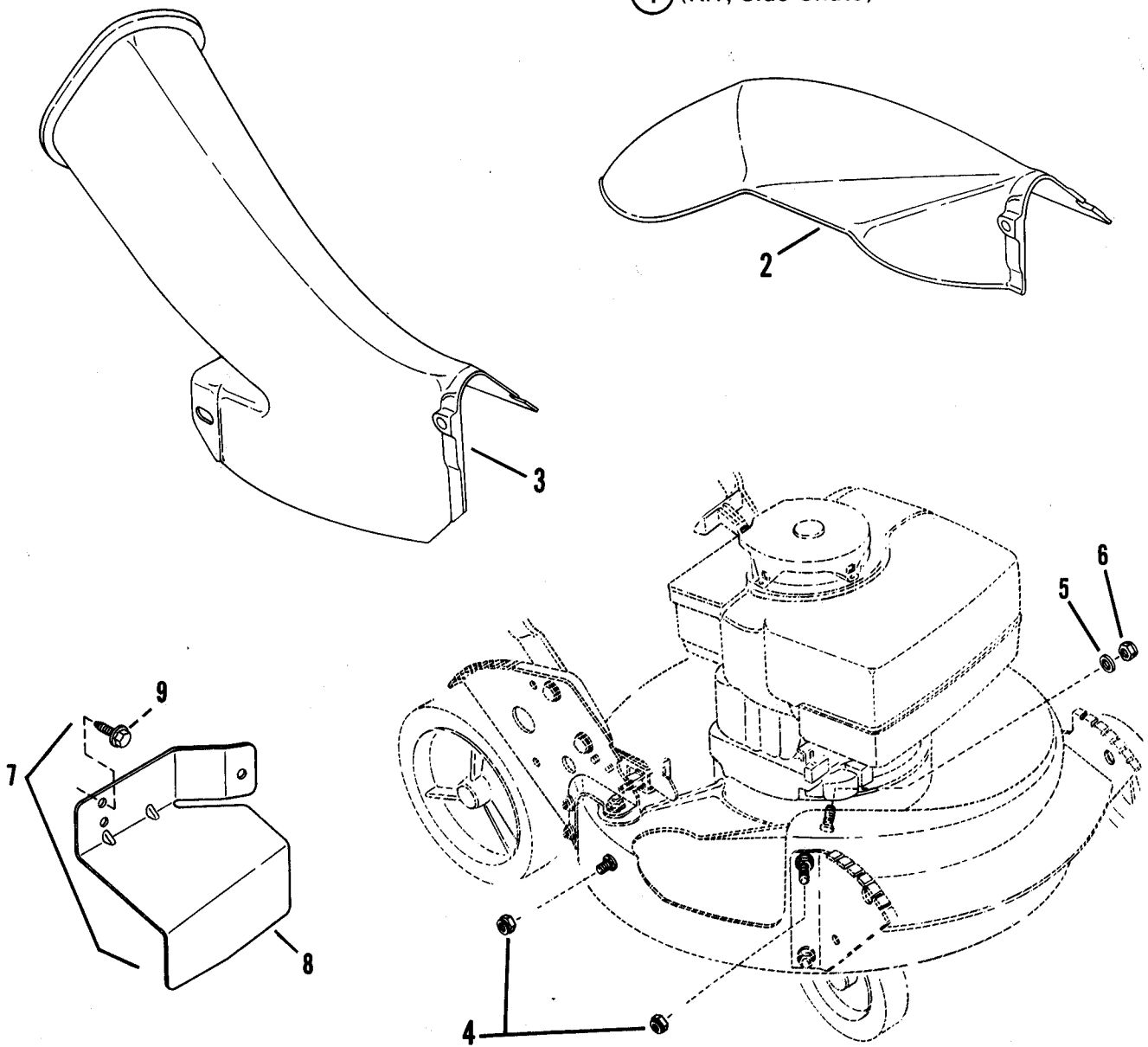

ITEM	PART NO.	DESCRIPTION
1	6-0542	KIT, Side Chute (Includes item 2)
2	1-9953	CHUTE, Side
3	1-6027	ADAPTER, Grass Bag Deck (Replace 1-9942)
4	9-0851	NUT, 5/16-18 Hex Lock (2)
5	9-0188	WASHER, 5/16 Flat
6	9-0951	NUT, 5/16-18 Hex Flange Lock
*7	6-0866	KIT, Exhaust Shield (Includes items 8&9)
*8	3-8391	SHIELD, Exhaust Heat
*9	9-0531	SCREW, #10-16x1/2" Self-Tapping (3)
-	6-0723	KIT, KWIK-N-EZY (See page 6.1)

\*BRIGGS & STRATTON ONLY

# CUTTING DECK, BLADE, INTERLOCK

REAR WHEEL BRACKETS  
See Pages 5.1-5.2.

DECK BRACKET  
See Pages 4.1-4.2

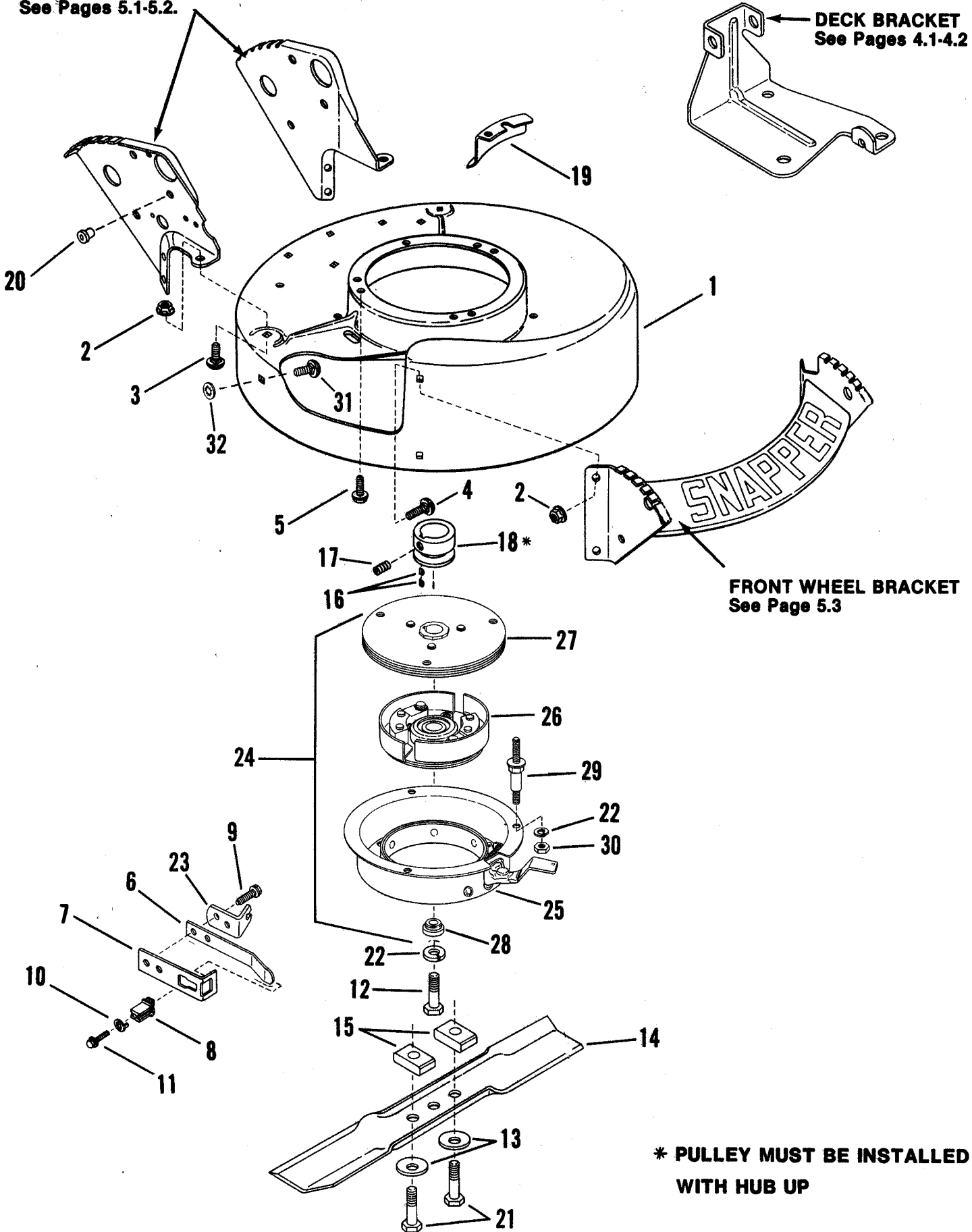

FRONT WHEEL BRACKET  
See Page 5.3

**\* PULLEY MUST BE INSTALLED  
WITH HUB UP**



# CUTTING DECK, BLADE, INTERLOCK

ITEM	PART NO.	DESCRIPTION
1	5-1598	DECK, Mower (Includes painted Deck with decals)
2	9-0585	NUT, Hex Flanged Lock (10)
3	9-0731	BOLT, 5/16-18x1/2" Short Neck Carriage Gr. 5 (9)
4	9-0383	BOLT, 5/16-18x1" Short Neck Carriage (4)
5	9-0324	SCREW, 3/8-16x1" Hex Head Self-tapping (Engine Mounting) (3)(Push Models)
*	9-0595	BOLT, 5/16-18x3/4" Hex Flange Lock (3) (Used on Robin Eng. Only)
6	3-2417	SPRING, Wheel Bracket Type Interlock
7	3-2416	BRACKET, Wheel Bracket Type Interlock
8	1-2048	INSULATOR, Interlock
9	9-0539	SCREW, 1/4-20x1/2" Hex Self-tapping (2)
10	9-0385	WASHER, No. 8 TAB Int. Tooth Lock
11	9-0379	SCREW, No. 8-18x3/4" Hex Head Machine
12	9-0167	SCREW, 3/8-24x2.0" Hex Head Cap
13	1-2063	WASHER, Cone (2)
14	1-9795	BLADE, Cutter, (Robin) (Replaces 1-9702)
-	1-7002	BLADE, Cutter (B&S)
15	3-2175	SPACER, Blade (2)
16	1-0783	KEY, Hi-Pro
17	9-0201	SCREW, 5/16-18x5/16" Hex Socket Set
18	2-1707	PULLEY, Engine (Propelled Models Only) (7/8" I.D. x 1-7/8" O.D.)
-	1-5779	PULLEY, Engine (Propelled Models Only) (Robin) (7/8" I.D.x 2-1/8" O.D.)
19	3-1968	SHIELD, Cover, Belt Opening (Push Models Only)
20	1-2135	BUSHING, Interlock Wire
21	9-0503	SCREW, 3/8-16x1-3/4" Hex Head Cap (2)
22	9-0118	WASHER, 3/8 Split Lock (4)
23	3-2421	BRACKET, CABLE - BBC
24	5-9706	ASSEMBLY, Blade Clutch (Includes items 25 thru 28)
25	1-9785	ASSEMBLY, Bowl & Brake
26	1-4178	ASSEMBLY, Clutch Bearing
27	1-8511	ASSEMBLY, Flywheel
28	1-4176	WASHER, Blade
29	1-5095	STAND-OFF (3)
30	9-0613	NUT, 3/8-16 Hex Flange Lock (3)
31	9-0799	BOLT, 5/16-18x1" Short Neck Carriage (3)
32	1-1791	RETAINER, 5/16 Bolt (3)

# DRIVE SYSTEM-SELF PROPELLED

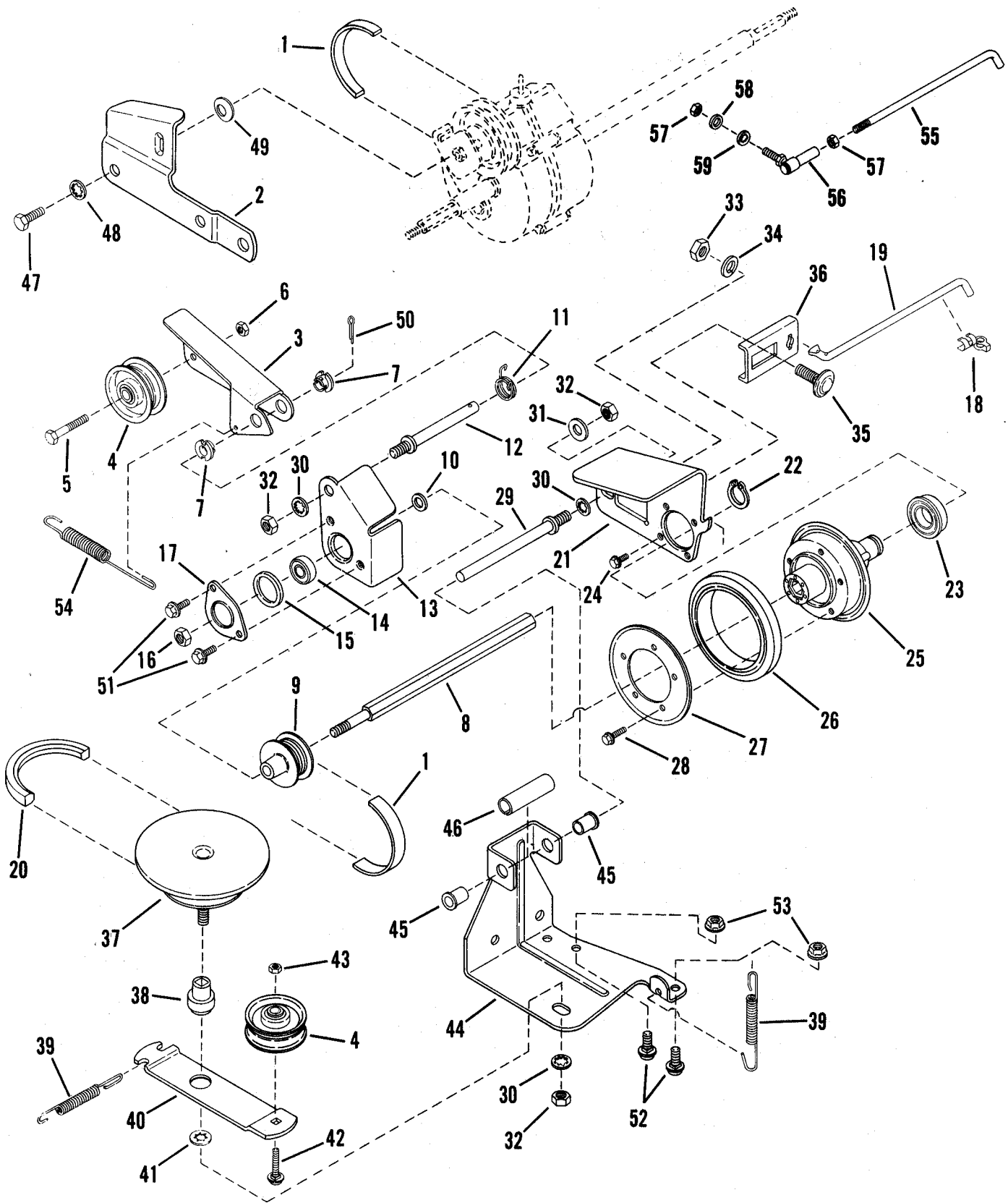

# DRIVE SYSTEM-SELF PROPELLED

ITEM	PART NO.	DESCRIPTION
1	1-2354	BELT, Poly-Vee
2	3-1880	LINK, Differential
-	5-0706	ASSEMBLY, Clutch Idler (Includes items 3 thru 7)
3	3-1877	ARM, Clutch Idler
4	1-2124	PULLEY, Idler
5	9-0552	CAPSCREW, 1/4-28x1-3/8" Hex Head
6	9-0303	NUT, 1/4-28 Hex Lock
7	1-2117	BUSHING, 3/8 I.D. Nylon (2)
8	2-1745	HEX-SHAFT
9	1-2140	PULLEY
10	1-2316	WASHER
11	1-2126	SPRING, Torsion
12	1-2111	STUD
13	3-1873	HOLDER, Bearing (Inner Half)
14	1-2304	BEARING, Ball
15	1-1025	O-RING
16	9-0289	NUT, 3/8 Hex Center Lock
17	3-1809	HOLDER, Bearing (Outer Half)
18	1-0937	CLIP, 1/4 Right Arc (Transfer Rod)
19	1-2255	ROD, Transfer
20	1-2508	BELT, Engine Drive
-	5-7444	ASSEMBLY, Driven Disc (Includes items 21 thru 28)
21	3-8154	PLATE, Thrust
22	1-0746	RING, Retaining
23	1-5474	BEARING, Ball
24	9-0981	SCREW, #10-32x1/4" Self-Tapping Machine (4)
25	5-1616	ASSEMBLY, Hub (Includes Bushing)
26	1-0927	DRIVEN-RING
27	3-1013	PLATE, Ring Retaining
28	9-0913	SCREW, #10-24x1/2 Self-Tapping Machine (5)
29	1-2125	GUIDE, Thrust Plate
30	9-0390	WASHER, 3/8 Internal Tooth Lock (2)
31	9-0122	WASHER, 3/8 Flat (3)
32	9-0155	NUT, 3/8-24 Hex (3)
33	9-0196	NUT, 5/16-18 Hex
34	9-0187	WASHER, 5/16 Split Lock
35	9-0316	BOLT, 5/16-18x3/4 Carriage
36	3-1874	CONNECTOR, Transfer Rod
37	*	ASSEMBLY, Drive-Disc
38	*	BUSHING
39	1-3694	SPRING (Wheel Drive & Idler) (2)
40	3-2116	ARM, Idler
41	1-3847	RETAINER, 3/8 Bolt
42	9-0078	BOLT, 1/4-20x1-1/4" Carriage
43	9-0372	NUT, 1/4-20 Hex Center Lock
-	5-0751	ASSEMBLY, Deck Bracket (Includes items 44 thru 46)
44	3-1919	BRACKET, Deck
45	1-2306	BUSHING, Flange (2)
46	2-1758	SPACER
47	9-0534	SCREW, 5/16-18x1/2" Hex Head Cap
48	9-0391	WASHER, 5/16 Internal Tooth Lock
49	1-1079	WASHER, Spring
50	9-0555	COTTER-PIN, 3/32x1/2"
51	9-0539	SCREW, 1/4-20x1/2" Self-Tapping
52	9-0731	BOLT, 5/16-18x5/8" Short Neck Carriage (2)
53	9-0585	NUT, 5/16-18 Hex Flange Lock (2)
54	1-2122	SPRING, Clutch
55	1-5752	LINK, Transfer ('89 Models & Later)
56	1-5753	JOINT, Ball ('89 Models & Later)
57	9-0095	NUT, 1/4-28 Hex ('84 Models & Later)
58	9-0055	WASHER, 1/4 Flat ('89 Models & Later)
59	9-0053	WASHER, 1/4 Internal Tooth Lock ('89 Models & Later)

\* NOTE: Order Kit #6-0710 for replacement.

# TRANSMISSION (DIFFERENTIAL) ('88 MODELS & EARLIER)

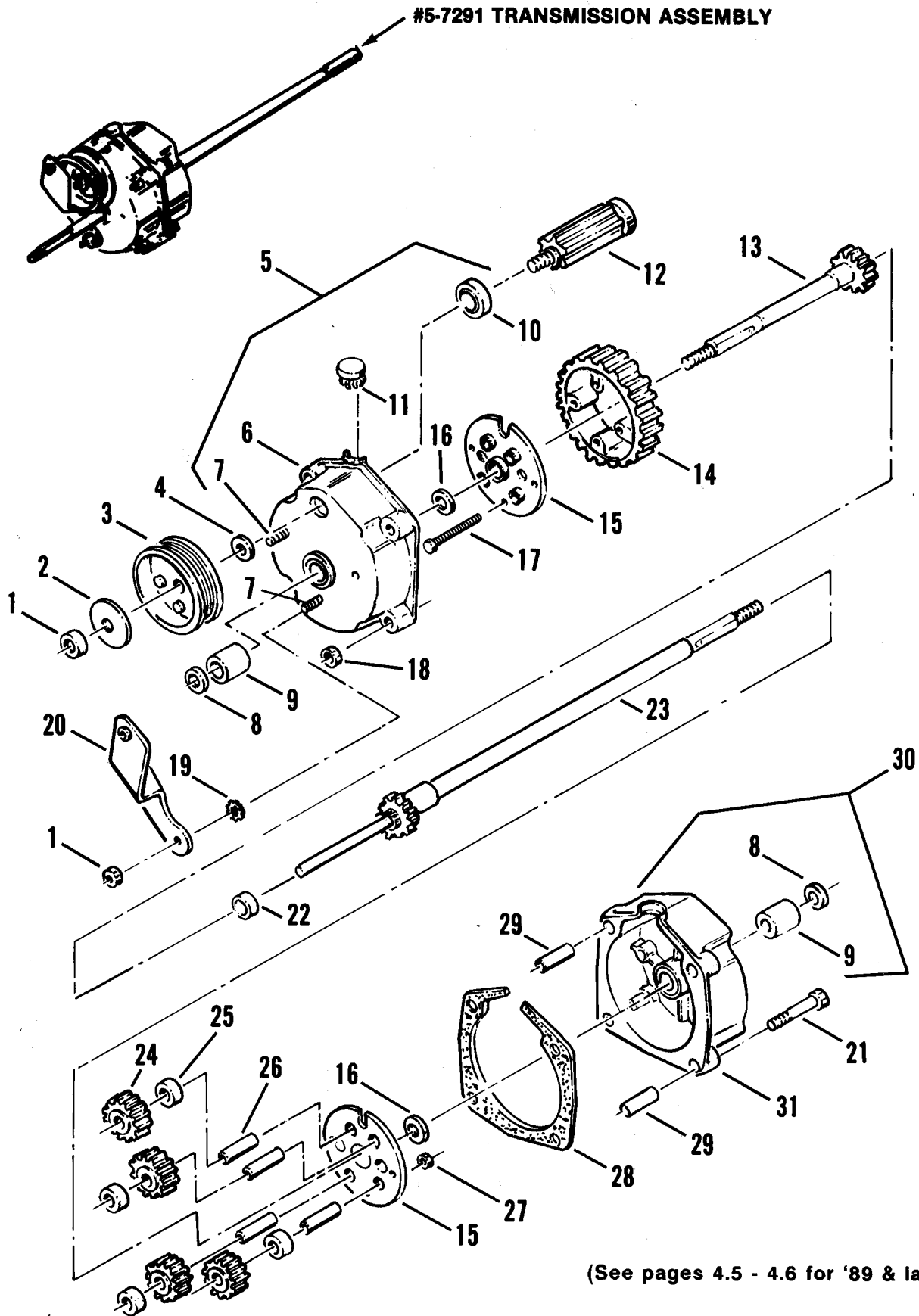

(See pages 4.5 - 4.6 for '89 & later)

# ('88 MODELS & EARLIER) TRANSMISSION (DIFFERENTIAL)

ITEM	PART NO.	DESCRIPTION
-	5-7291	ASSEMBLY, Transmission (Includes items 1 thru 31)
1	1-1201	NUT, 5/16-24 Hex Lock (3)
2	1-1132	WASHER, Spring
3	1-2109	PULLEY, Poly-Vee Belt
4	1-1724	WASHER, Spring
5	5-7290	HOUSING ASSEMBLY, Right (Includes items 6,7,8,9,10)
6	1-8512	HOUSING, Right Side
7	1-4155	SCREW, 5/16-24x1-1/8" Rib Neck
8	1-2314	SEAL, 5/8" ID (2)
9	1-2507	BEARING, Differential (2)
10	1-1767	BEARING, Ball
11	1-1133	PLUG, Housing
12	5-0767	GEAR, Input
13	5-0830	AXLE, Short
14	1-2495	GEAR, Differential, 46 Tooth
15	3-1970	PLATE (2)
16	3-1965	WASHER, Thrust (2)
17	9-0557	SCREW, 10-32x1-1/2" Hex Head Cap (4)
18	9-0303	NUT, 1/4-28 Hex Lock
19	9-0189	WASHER, 5/16" Internal External Tooth Lock
20	4-0474	BRACKET, Differential
21	9-0552	SCREW, 1/4-28x1-3/8 Hex Head Cap (4)
22	1-2543	SPACER, Axle Gear
23	5-0831	AXLE, Long
24	2-1115	GEAR, Pinion, 12 Tooth (4)
25	1-2500	SPACER, Pinion Gear (4)
26	1-1110	SHAFT, Pinion (4)
27	9-0376	NUT, 10-32 Hex Lock (4)
28	1-1774	GASKET, Housing
29	1-2512	PIN, 3/8-7/16" Roll (2)
30	5-7245	HOUSING ASSEMBLY, Left (Includes items 8,9,31)
31	1-8216	HOUSING, Left Side

NOTE: 6-0337 KIT, Transmission Gear (includes items 14 thru 17 & 22 & 24 thru 27)

# TRANSMISSION (DIFFERENTIAL) ('89 MODELS & LATER)

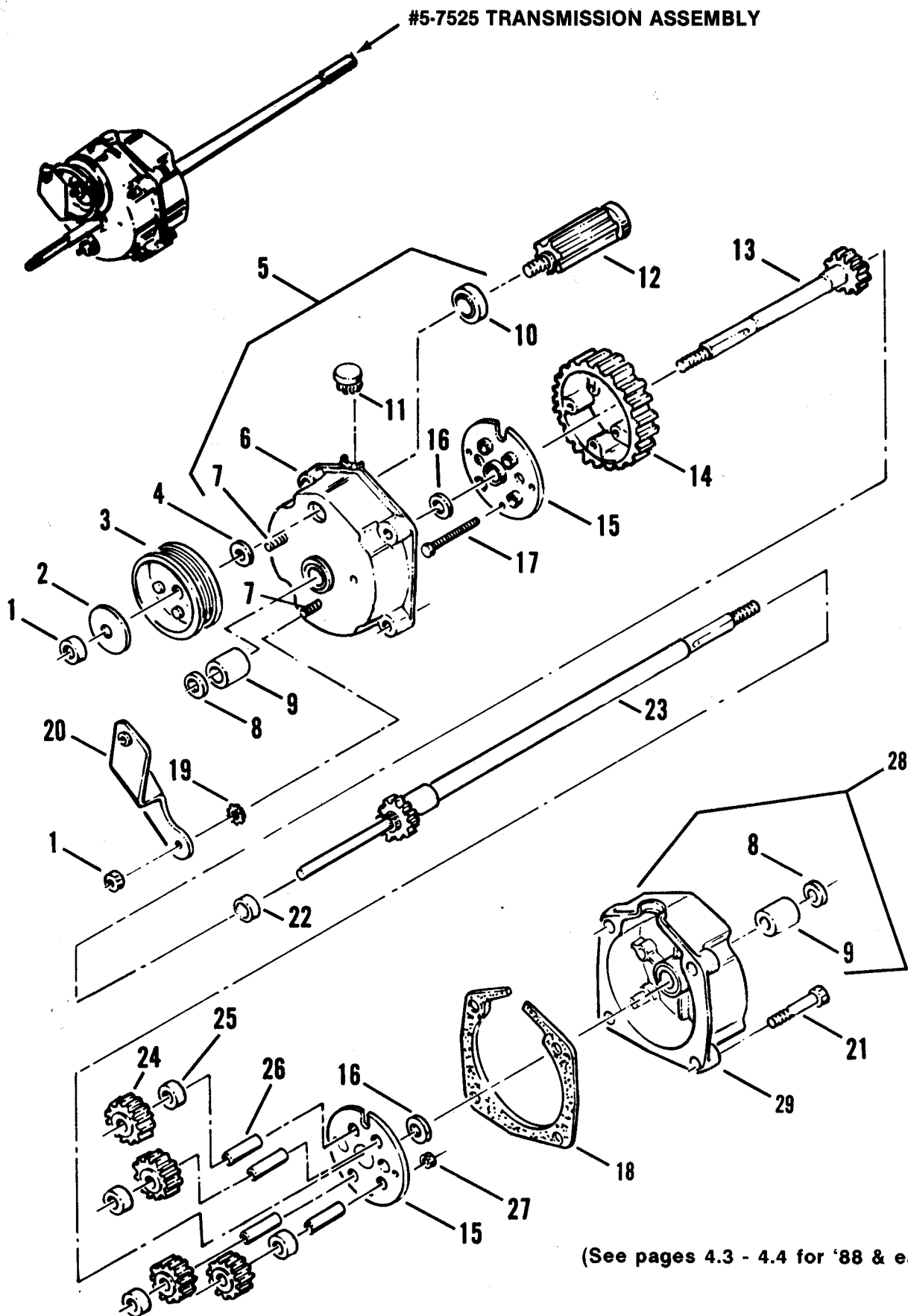

(See pages 4.3 - 4.4 for '88 & earlier)

# '89 MODELS & LATER) TRANSMISSION (DIFFERENTIAL)

ITEM	PART NO.	DESCRIPTION
-	5-7525	ASSEMBLY, Transmission (Includes items 1 thru 29)
1	1-1201	LOCKNUT, 5/16-24 Hex (3)
2	1-1132	WASHER, Spring
3	1-2109	PULLEY, Poly-Vee Belt
4	1-1724	WASHER, Spring
5	5-7522	HOUSING ASSEMBLY, Right (Includes items 6,7,8,9,10)
6	1-7014	HOUSING, Right Side
7	1-4155	SCREW, 5/16-24x1-1/8" Rib Neck (2)
8	1-2314	SEAL, 5/8" ID (2)
9	1-2507	BEARING, Differential (2)
10	1-1767	BEARING, Ball
11	1-1133	PLUG, Housing
12	5-0767	GEAR, Input
13	5-0830	AXLE, Short
14	1-2495	GEAR, Differential, 46 Tooth
15	3-1970	PLATE (2)
16	3-1965	WASHER, Thrust (2)
17	9-0557	SCREW, Cap, 10-32x1-1/2" (4)
18	1-1774	GASKET, Housing
19	9-0189	WASHER, 5/16" Internal External Tooth Lock
20	4-0474	BRACKET, Differential
21	9-0911	SCREW, 1/4-20x1-1/4 Self-Tapping (4)
22	1-2543	SPACER, Axle Gear
23	5-0831	AXLE, Long
24	2-1115	GEAR, Pinion, 12 Tooth (4)
25	1-2500	SPACER, Pinion Gear (4)
26	1-1110	SHAFT, Pinion (4)
27	9-0376	LOCKNUT, 10-32 (4)
28	5-7523	HOUSING ASSEMBLY, Left (Includes items 8,9,29)
29	1-7015	HOUSING, Left Side

# REAR WHEELS, BRACKETS, LATCHES

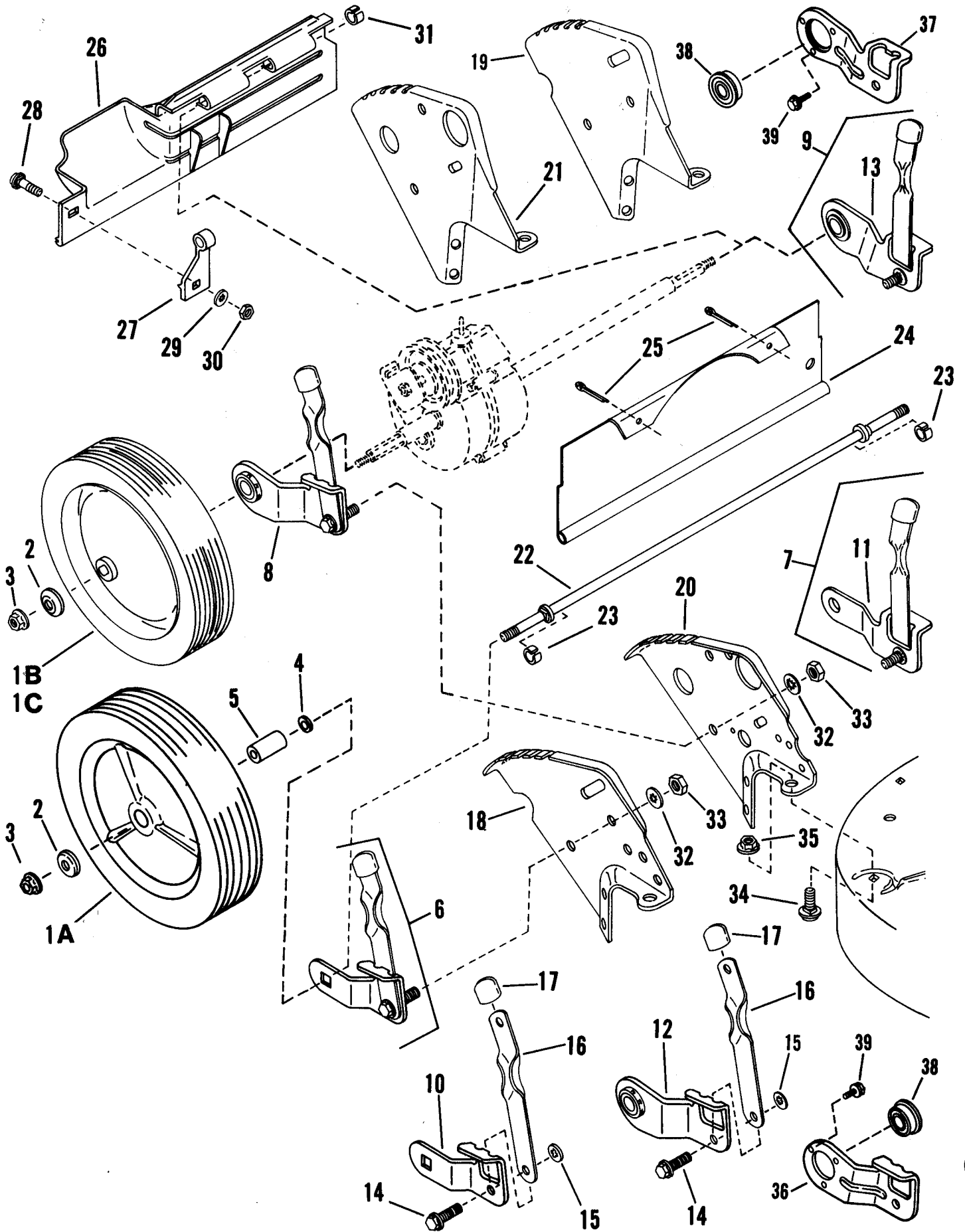



# REAR WHEELS, BRACKETS, LATCHES

ITEM	PART NO.	DESCRIPTION
1A	1-2579	WHEEL, 9x1.75 Plastic Rim (Push Models) (B&S)
1B	1-4604	WHEEL, 9x1.75 Steel Rim (Self Propelled Models) (B&S)
1C	1-2345	WHEEL, 9x1.95 (Self-Propelled Models) (Robin)
2	3-1960	HUB-CAP (Self-Propelled Models)
3	9-0394	NUT, 7/16-20 Hex Center Lock
4	3-1961	WASHER, Steel (Push Models)
5	1-2309	BUSHING, Axle (Used with item 1B)
6	5-0760	WHEEL ARM ASSEMBLY (Front Left & Rear Right) Square opening-(Includes items 10,14,15,16,17) (Push Models)
7	5-0761	WHEEL ARM ASSEMBLY (Front Right & Rear Left) Round opening-(Includes items 11,14,,15,16,17) (Push Models)
8	5-7402	WHEEL ARM ASSEMBLY (Rear Right "P" Models) (Includes items 12,14,15,16,17)
9	5-7401	WHEEL ARM ASSEMBLY (Rear Left "P" Models) (Includes items 13,14,15,16,17)
10	3-1016	ARM (Square Axle End)
11	3-1017	ARM (Round Axle End)
12	5-1558	ARM & BEARING ASSEMBLY, Rear Right "P" Models
13	5-1557	ARM & BEARING ASSEMBLY, Rear Left "P" Models
14	1-5761	BOLT, 5/16-18x1 Shoulder
15	1-1791	RETAINER, 5/16 Bolt
16	1-2325	LATCH, Height Adjusting
17	1-1093	GRIP, Latch
18	3-6050	BRACKET, Right Rear Wheel (Push Models)
19	3-6049	BRACKET, Left Rear Wheel (Push Models)
20	3-6048	BRACKET, Right Rear Wheel (Self-prop. "P" Models)
21	3-6242	BRACKET, Left Rear Wheel (Self-prop. "P" Models)
22	2-1119	AXLE, (Rear on Push Models also front on all)
23	1-1780	RING (2)
24	3-7765	GUARD, Rear Foot (Push Models) ('88 Models & Earlier)
-	1-9068	GUARD, Rear Foot (Push Models) (Plastic) ('89 Models & Later)
25	9-0297	COTTER PIN, 1/8x1-1/2" (2) ('88 Models & Earlier)
26	1-9522	GUARD, Rear Foot (Self-prop. "P" Models)
27	1-2616	SUPPORT, Foot Guard
28	9-0005	BOLT, 1/4-20x1/2 Short Neck Carriage Gr.5
29	9-0053	WASHER, 1/4 Int. Tooth Lock
30	9-0063	NUT, 1/4-20 Hex
31	1-0996	RING
32	9-0391	WASHER, 5/16 Int. Tooth Lock
33	9-0196	NUT, 5/16-18 Hex
34	9-0731	BOLT, 5/16-18x1/2 Short Neck Carriage
35	9-0585	NUT, 5/16-18 Hex Flange Lock
36	3-2722	ARM, Wheel Rear Right "P" Models) ('89 Models & Later)
37	3-2723	ARM, Wheel Rear Left "P" Models ('89 Models & Later)
38	1-8767	BEARING
39	4-0981	SCREW, #10-32 x 1/4" Self-Tapping (3)

# FRONT WHEELS, BRACKET, LATCHES

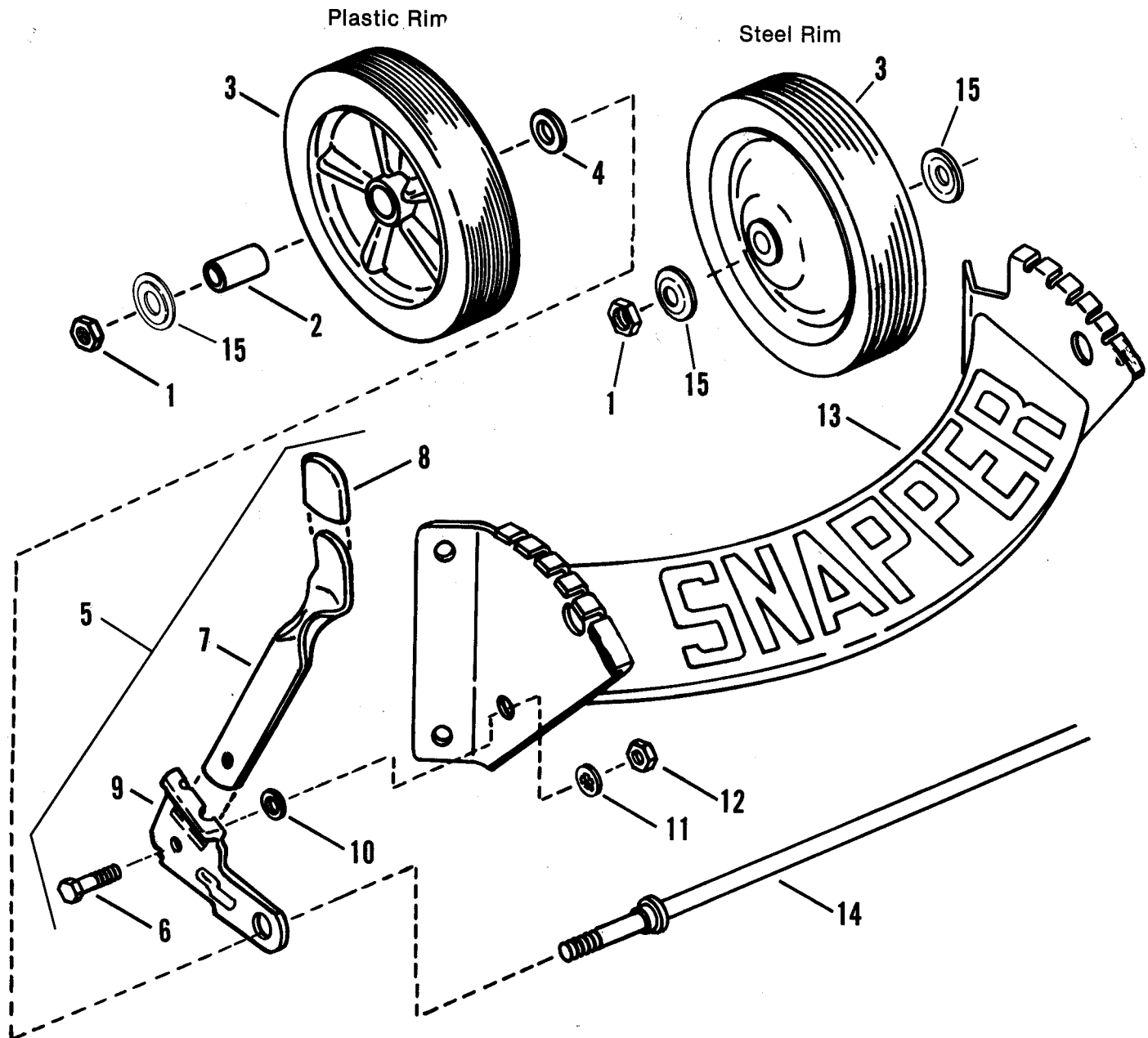

ITEM	PART NO.	DESCRIPTION
1	9-0394	NUT, 7/16-20 Hex Centerlock
2	1-2309	BUSHING, Axle (2)
3	1-8189	WHEEL, Front, (7x1.50 Plastic Rim) (2) (B&S)
-	1-2347	WHEEL, Front (7x1.75 Steel Rim) (2) (Robin)
4	3-1961	WASHER, Steel (2)
5A	5-0760	ARM ASSEMBLY, Left Wheel (Consists of Items 8,9,10,11A,12)
5B	5-0761	ARM ASSEMBLY, Right Wheel (Consists of Items 8,9,10,11B,12)
6	1-5761	BOLT, 5/16-18 Shoulder
7	1-2325	LATCH, Height
8	1-1093	GRIP
9A	3-1016	ARM, Left Wheel
9B	3-1017	ARM, Right Wheel
10	1-1791	RETAINER, 5/16 Bolt
11	9-0391	WASHER, 5/16 Int. Toothlock
12	9-0196	NUT, 5/16-18 Hex
13	4-7815	BRACKET, Front Wheel
14	2-1119	AXLE
15	3-1121	HUB-CAP (2 per wheel)

① KIT

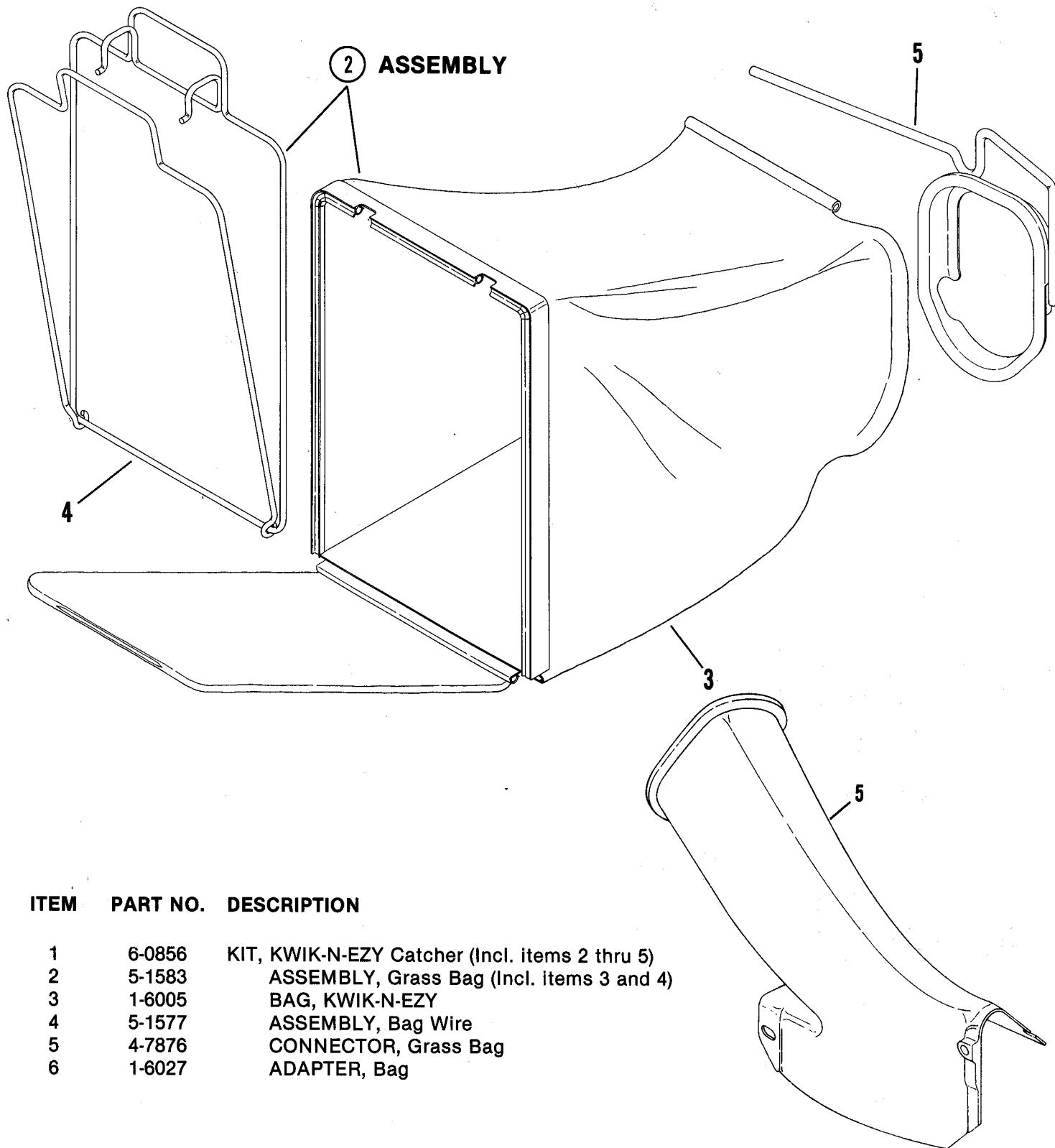

ITEM	PART NO.	DESCRIPTION
1	6-0856	KIT, KWIK-N-EZY Catcher (Incl. items 2 thru 5)
2	5-1583	ASSEMBLY, Grass Bag (Incl. items 3 and 4)
3	1-6005	BAG, KWIK-N-EZY
4	5-1577	ASSEMBLY, Bag Wire
5	4-7876	CONNECTOR, Grass Bag
6	1-6027	ADAPTER, Bag

NOTE: Exhaust Shield required with Briggs & Stratton 3.5 & 4 HP engines (SEE PAGE 2.1)

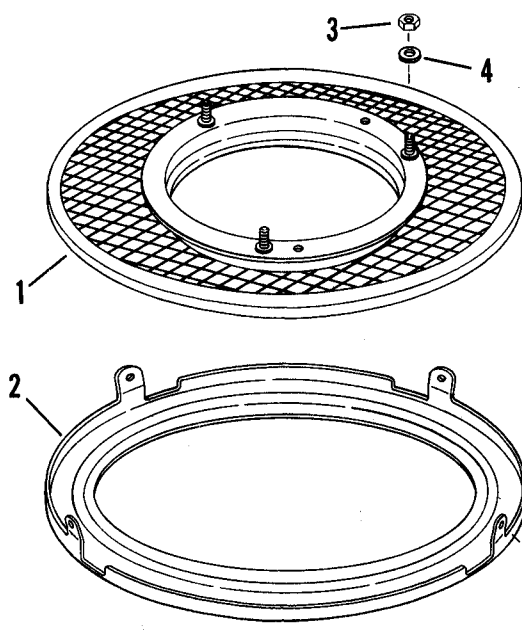

ITEM	PART NO.	DESCRIPTION
-	6-0440	KIT, Snapperizer (Includes items 1 thru 5)
1	5-1243	SCREEN, Fastener Assembly
2	3-9759	RING, Bottom
3	9-0223	NUT, 5/16-24 Hex (3)
4	9-0187	WASHER, 5/16 Split Lock (3)
5	1-2587	SPRING (3)

**DECALS**

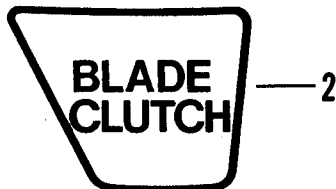

ITEM	PART NO.	DESCRIPTION
1	1-3010	DECAL, CPSC (Danger)
2	1-5203	DECAL, Blade Clutch
3	1-4944	DECAL, Warning
4	1-4945	DECAL, Blade Start
5	1-5489	DECAL, 4 HP

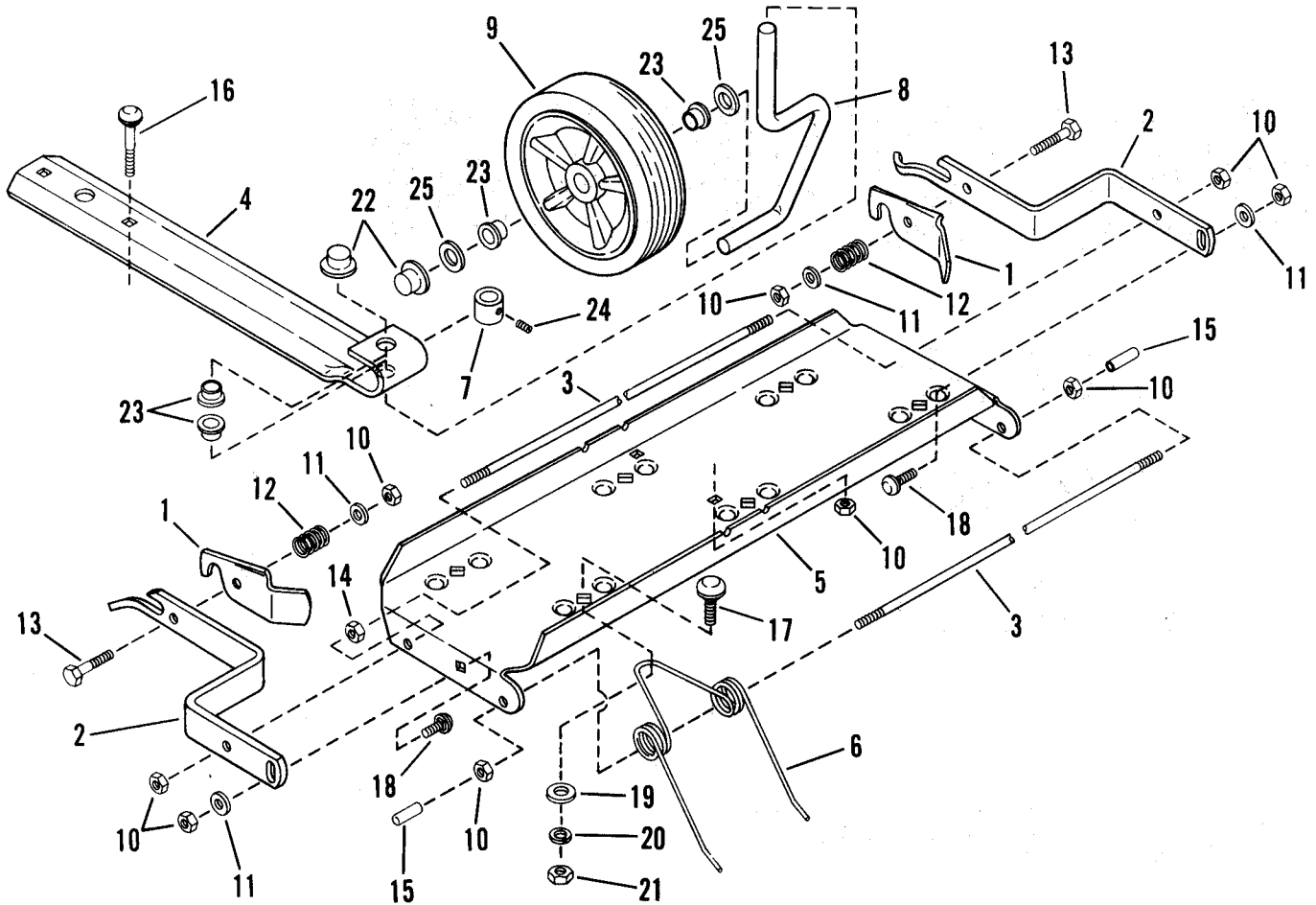

ITEM	PART NO.	DESCRIPTION	ITEM	PART NO.	DESCRIPTION
-	6-0476	KIT, Thatcherizer (Includes 1 thru 27)			
1	1-4113	LATCH, Frame Attachment (2)	14*	9-0063	NUT, 1/4-20 Hex (2)
2A	1-8497	BAR, Mount (Right Hand)	15**	1-4111	CAP, Vinyl (2)
2B	1-8498	BAR Mount (Left Hand)	16*	9-0015	BOLT, 1/4-20x1-3/4 Carriage (2)
3	1-8499	ROD, Tine (2)	17*	9-0383	BOLT, 5/16-18x1 Carriage (6)
4	1-8700	SUPPORT, Wheel	18*	9-0074	BOLT, 1/4-20x3/4 Carriage (2)
5	1-9948	TRAY, Tine	19*	1-4098	WASHER, Reinforcing (6)
6***	1-8496	SPRING, Tine Thatching (6)	20*	9-0187	LOCKWASHER, 5/16 (6)
7**	1-4100	BUSHING, Wheel Adj.	21*	9-0196	NUT, 5/16-18 Hex (6)
8	1-8493	AXLE, Wheel	22**	1-4101	PUSH NUT, 1/2 (2)
9	1-8189	WHEEL, Gage 7x1.50	23**	1-4342	BEARING, Nyliner (4)
10*	9-0761	LOCKNUT, 1/4-20 Hex (10)	24**	1-4103	SETSCREW, 5/16x1/4
11*	9-0598	WASHER, 1/4 SAE (4)	25*	9-0250	WASHER, 1/2 (2)
12**	1-4114	SPRING, Compression (2)	26	1-4115	DECAL, Adjustment (Not Shown)
13*	9-0825	BOLT, 1/4-20x1-1/4 Hex (2)	27	1-4062	DECAL, Thatcherizer (Not Shown)

\*Part of Hardware Bag #6-0554

\*\*Part of Hardware Bag #6-0555

\*\*\*Part of Hardware Bag #6-0574 (6 spring in bag)

Parts Manual for

# **SNAPPER**<sup>®</sup>

**BLADE  
BRAKE  
CLUTCH**

**WALK BEHIND  
MOWERS**

IT IS THE POLICY OF SNAPPER POWER EQUIPMENT TO IMPROVE ITS PRODUCTS WHENEVER IT IS POSSIBLE AND PRACTICAL TO DO SO. WE RESERVE THE RIGHT TO MAKE CHANGES OR ADD IMPROVEMENTS AT ANY TIME WITHOUT INCURRING ANY OBLIGATION TO MAKE SUCH CHANGES ON PRODUCTS MANUFACTURED PREVIOUSLY.

**SNAPPER POWER EQUIPMENT**  
McDonough, GA • 30253



**MANUAL #06131**

**(REV.12/88)**

**Printed in U.S.A.**

Download from [www.Somanuals.com](http://www.Somanuals.com). All Manuals Search And Download.

## Free Manuals Download Website

<http://myh66.com>

<http://usermanuals.us>

<http://www.somanuals.com>

<http://www.4manuals.cc>

<http://www.manual-lib.com>

<http://www.404manual.com>

<http://www.luxmanual.com>

<http://aubethermostatmanual.com>

Golf course search by state

<http://golfingnear.com>

Email search by domain

<http://emailbydomain.com>

Auto manuals search

<http://auto.somanuals.com>

TV manuals search

<http://tv.somanuals.com>