

SERVICE MANUAL

for

SNAPPER®

1600, 1650, 1855

SERIES

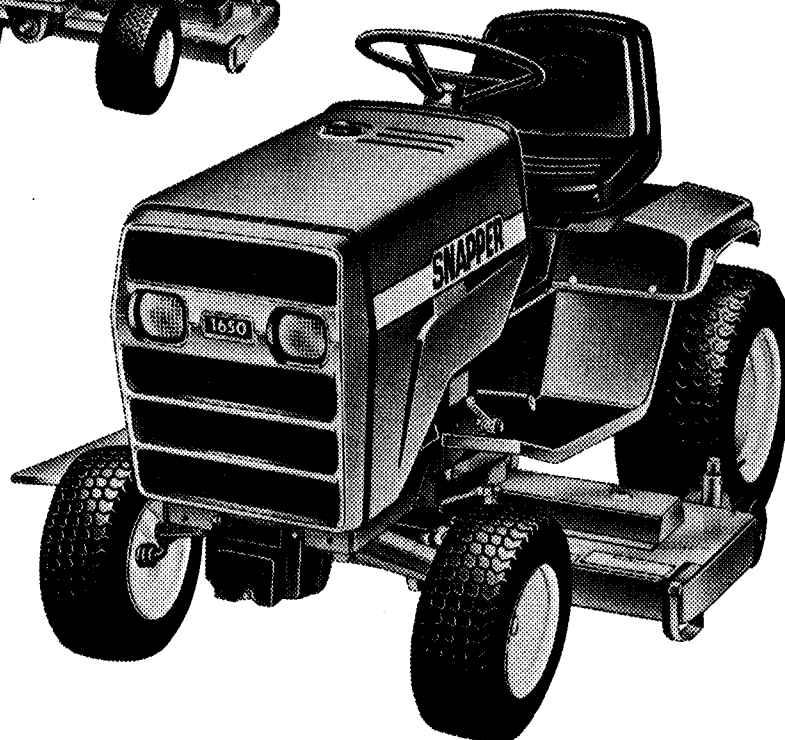
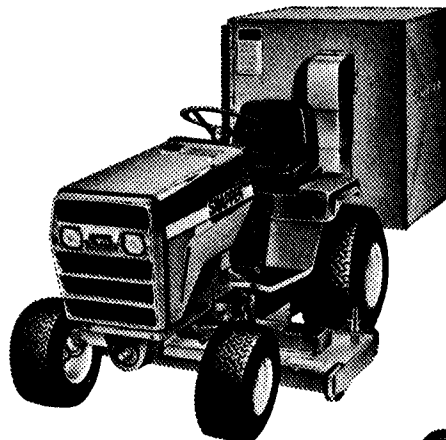

**GARDEN TRACTORS
& MOWER ATTACHMENTS**

SNAPPER POWER EQUIPMENT

McDonough, GA • 30253

E/I

**FUGUA
INDUSTRIES
Company**

#07005

Download from www.Somanuals.com. All Manuals Search And Download.

SERVICE SECTION INDEX

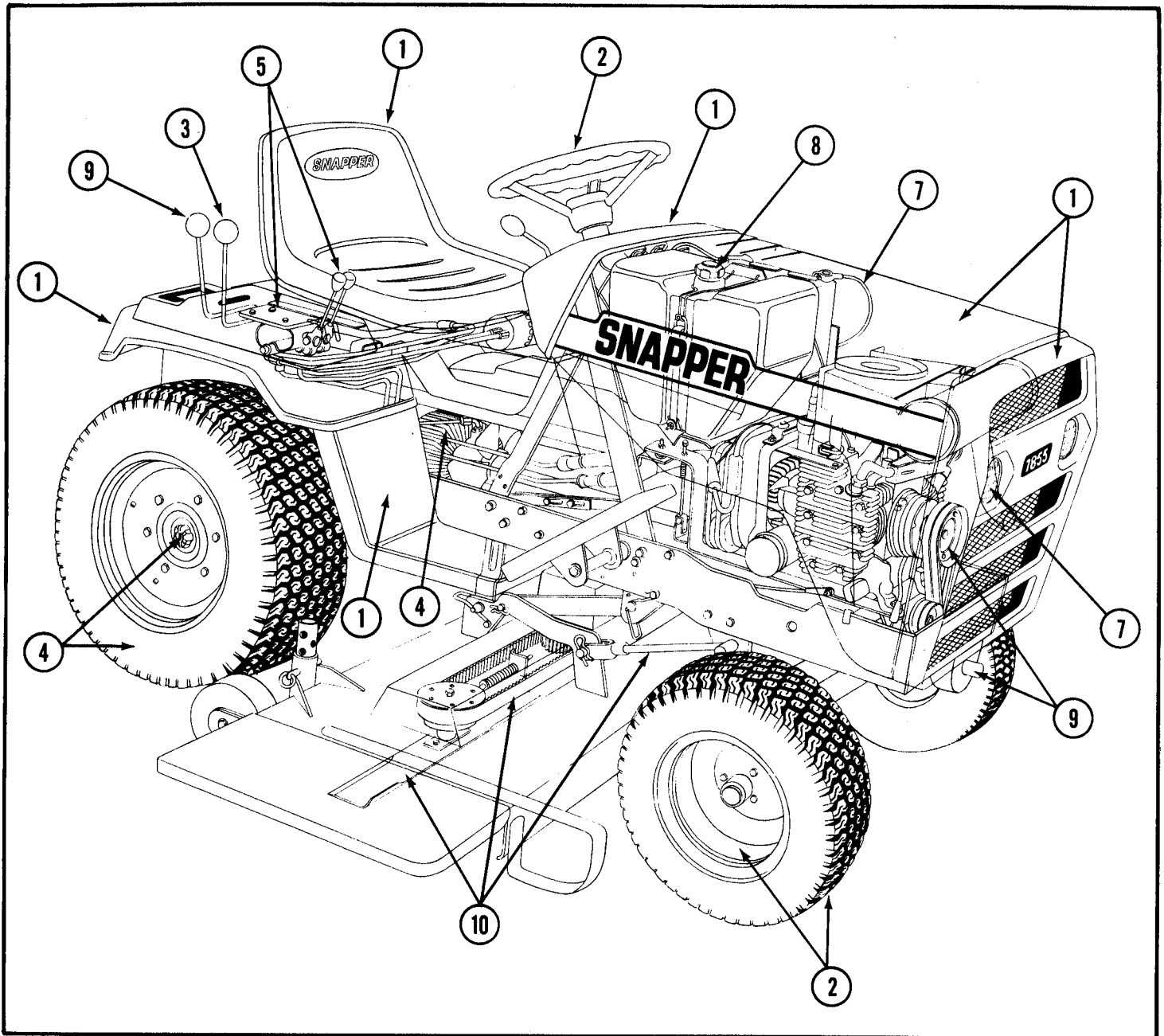

SECTION # & COVERAGE

- 1 SHEET METAL, PANELS, SEAT
- 2 STEERING, FRONT AXLES & WHEELS
- 3 BRAKING & TRANSMISSION CONTROLS
- 4 TRANSMISSIONS, REAR AXLES & WHEELS
- 5 HYDRAULIC LIFT SYSTEMS

SECTION # & COVERAGE

- 6 ENGINE TROUBLE SHOOT & REMOVAL
- 7 ELECTRICAL SYSTEMS
- 8 FUEL SYSTEMS
- 9 POWER TAKE OFF SYSTEMS
- 10 MOWERS & MOWER DRIVES

SECTION 1 — SHEET METAL & OPERATOR'S SEAT

INTRODUCTION

Removal of items such as the console cover, rear fender, side panels and hood will be required in certain repair situations to gain complete access to other tractor components. Detailed instructions for removal and reinstallation of these items plus the operator's seat are covered in this first section only. Where removal is required in the following sections, it will be mentioned briefly as one of the procedural steps.

CONSOLE COVER

Removal of the console cover allows access to the clutch-brake interlocks, mid-mount implement hydraulic lift cylinder, steering gear and other items. The cover is quickly removed as follows:

STEP 1: Turn the knob in counterclockwise direction and remove from the gearshift or speed control lever.

STEP 2: Use screwdriver to remove the four phillips head screws securing the cover to the side panels and lift the cover off.

STEP 3: Reverse the foregoing procedure to reinstall the cover after making necessary repairs or adjustments.

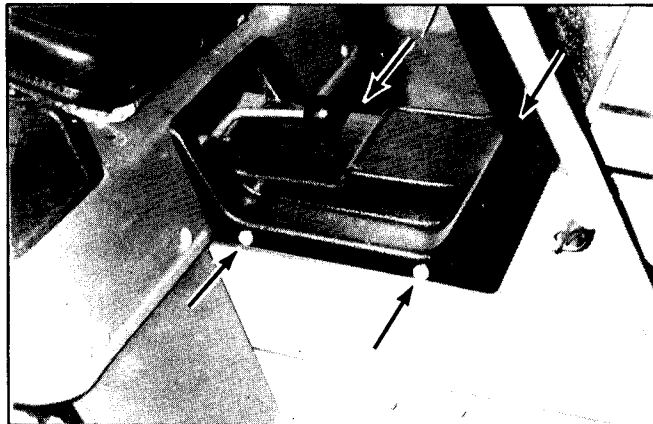

FIG. 1.1 -- CONSOLE-1600 SERIES

REAR FENDER

Limited access to components located under the center of the rear fender can be gained by raising the seat and lifting the tool tray out of the recess in the fender. For complete access, remove the fender with the operator's seat attached as follows:

STEP 1: Disconnect electrical leads at the terminals to the tail-lights, seat interlocks and rear P.T.O. interlocks if so equipped.

STEP 2: Turn the knobs off the levers on the control console on right side of the fender.

STEP 3: Slide the operator's seat into full forward position then raise the seat and remove the two bolts at the rear of the seat rails.

STEP 4: Remove the four carriage bolts securing the lower front edges of the fender to the step plates.

STEP 5: Lift the fender-seat assembly off the frame. After making necessary repairs, reverse the foregoing procedure to reinstall the fender and reconnect wiring.

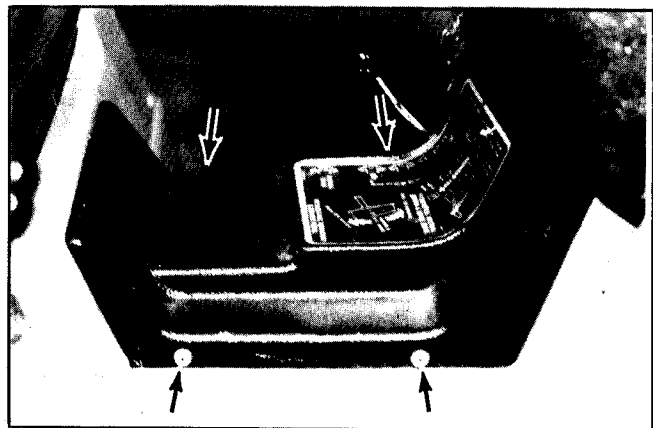

FIG. 1.2 -- CONSOLE-1650 & 1855

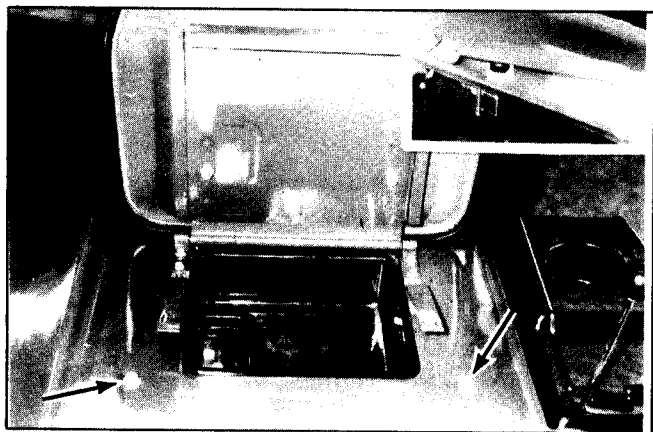

FIG. 1.3 -- FENDER/SEAT-1600 SERIES

SEAT & SEAT RAILS

If the operators seat has to be replaced simply tilt it forward and remove the four flange lock bolts securing the seat to the hinge frame assembly, install the replacement seat and secure with the same hardware. If seat rail replacement is required, proceed as follows:

STEP 1: Separate the seat from the fender by removing one of the retaining rings from the end of the seat pivot pin then pull the pin and remove the seat.

STEP 2: Remove the two bolts securing each rail to the fender and the bolt at front securing the seat pivot frame to the rail. Replace the rail or rails and reverse the foregoing procedure to reassemble the components.

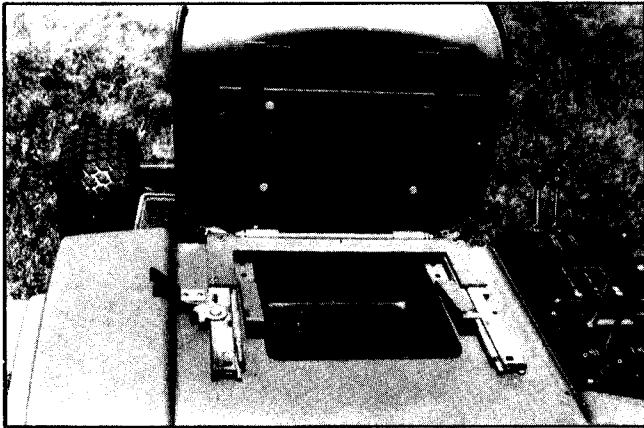

**FIG. 1.4 -- FENDER & SEAT ASSEMBLY
DETAIL - 1650 & 1855 SERIES**

INSTRUMENT (DASH COWL) PANEL

The steering wheel must be pulled to replace the instrument panel. Refer to section two for steering wheel removal procedure. After pulling the steering wheel, lift the hood and proceed as follows to replace the instrument panel.

STEP 1: Disconnect and remove the ammeter and hourmeter if so equipped.

STEP 2: Disconnect throttle and choke cables and pull cables out of the panel.

STEP 3: Remove retaining nuts from the choke, ignition and PTO switches. Turn the knob off the speed control lever.

STEP 4: Use a phillips head screwdriver to remove the four screws securing the panel to the pedestal frame then remove the panel. Reverse the foregoing procedure to install the replacement panel and to reassemble the instruments and controls.

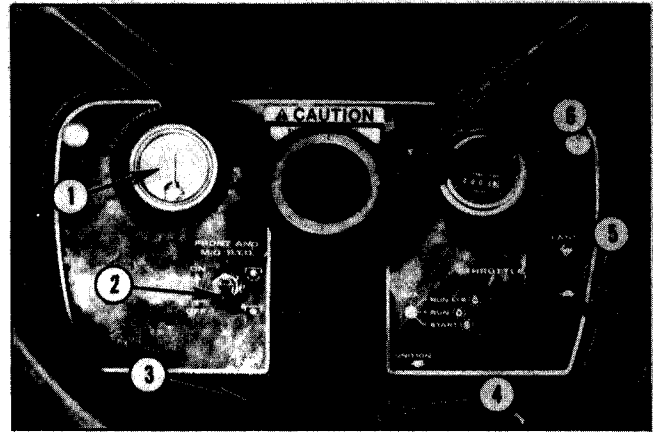

FIG. 1.5 -- INSTRUMENT PANEL DETAIL

- | | |
|---------------|-----------------------|
| 1. AMMETER | 4. IGNITION |
| 2. PTO SWITCH | 5. THROTTLE |
| 3. CHOKE | 6. HOURMETER (OPTION) |

HOOD & GRILLE

Tilting the hood full forward usually provides sufficient access for most front area works, however, it is easily from the tractor as follows:

STEP 1: Tilt the hood assembly forward and unplug the headlight wires at the terminals.

STEP 2: Tilt the hood backward enough to take tension off the stop cable, then pull the hair pin from the clip and disconnect the cable.

STEP 3: With the hood tilted forward, lift upward and pull forward until the tilt hinges on both sides clear the slots in the frame front cross member.

STEP 4: If the grille is to be removed, turn the flange locknuts off the seven studs welded to the forward edges of the hood. Disengage the studs from the grille tabs and separate these items. The screen can now be removed from the inside of the grille if required. Reverse the foregoing procedure to reassemble and reinstall hood components.

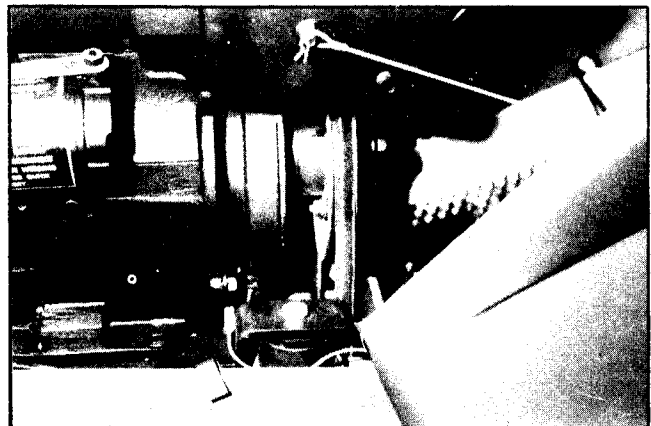

FIG. 1.6 -- ACCESS WITH HOOD FORWARD

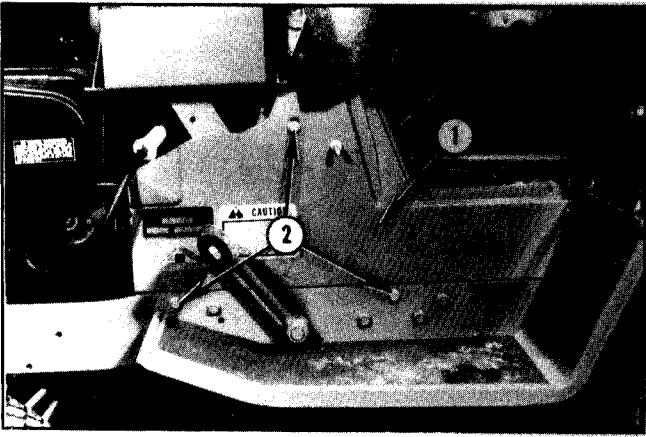

FIG. 1.7 -- LEFT PANEL (1) & ATTACHMENT(2)

SIDE PANELS & STEP PLATES

The step plates do not normally have to be removed except for replacement purposes. Each step plate is attached to the rear fender at two points and to the frame at two points. To replace, simply remove these fasteners, install the replacement plate and secure with the same fasteners.

The side panels are often removed for access to other components inside the tractor frame. These are easily removed as follows:

STEP 1: Remove the console cover as described earlier in the section.

STEP 2: Each panel attaches to the frame at three points. Remove the three flange lock bolts (weldnuts on inside of frame) and lift the upward and outward to remove.

NOTE: When removing the right side panel on 1600 series, it will be necessary to detach the lift lever from the shaft before pulling the panel.

STEP 3: Reverse the foregoing steps to reinstall the side panels.

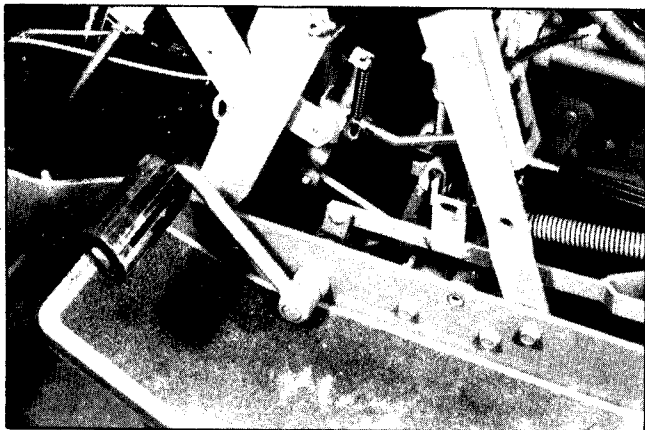

FIG. 1.8-- ACCESS WITH LEFT PANEL REMOVED

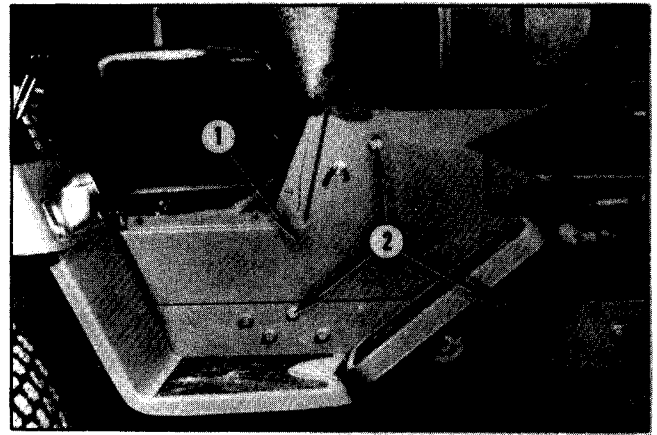

FIG. 1.9 -- RIGHT PANEL (1) & ATTACHMENT (2)

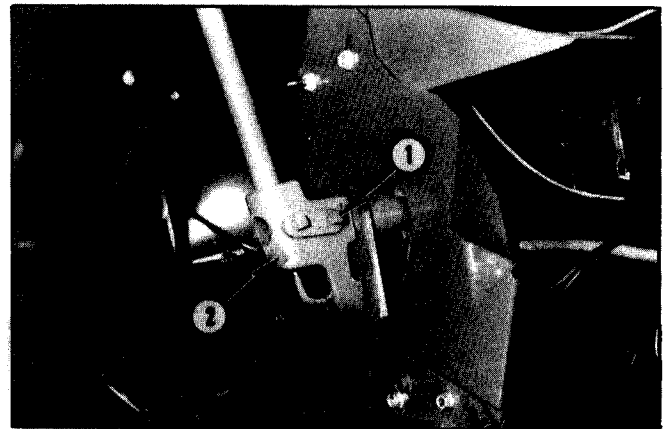

FIG. 1.10 -- 1600 LIFT LEVER SCREWS (1) & SUPPORT(2)

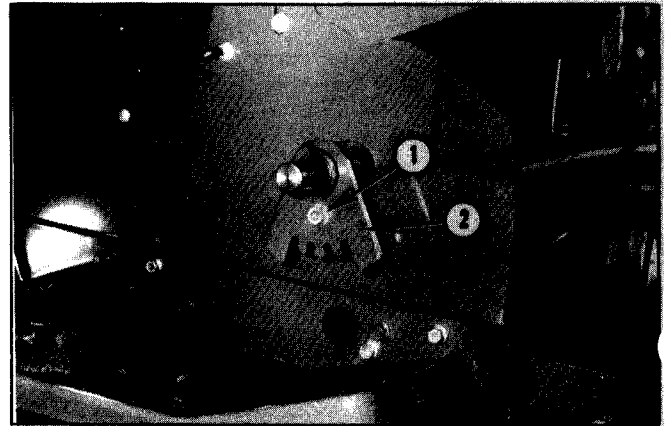

FIG. 1.11 -- 1600 LIFT SPECIAL NUT (1) & CAM(2)

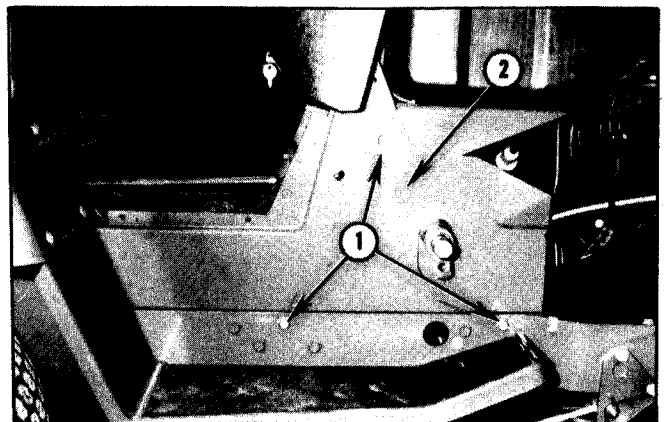

FIG. 1.12 -- 1600 RIGHT PANEL (2) & ATTACHMENT(1)

SECTION 2 - STEERING, & FRONT AXLE & WHEELS

The steering gear assembly used on the 1600 and 1650 series tractors is different than that used on the 1855 models. Because of this, the two types are described separately on the following pages of this section. The front power take-off is considered part of the front axle pivot on the 1855 and is therefore covered with the 1855 steering portion starting on page 2.5. The 1600-1650 series steering components are covered on pages 2.1—2.4.

STEERING GEAR ASSEMBLY REMOVAL (1600-1650)

1. Disconnect battery cables.
2. Remove fuel tank.
3. Remove cover over drive shaft and remove side shields.
4. Disconnect choke cable at engine.
5. Remove wire plug from ignition switch and PTO control switch.
6. Disconnect ammeter wires.
7. Remove steering wheel.
8. Remove retaining screws and lift instrument panel off tractor.
9. Disconnect hydraulic cylinder bracket and lower cylinder down as far as possible. Fig. 2.1.
10. Remove retaining bolts and lift steering gear assembly out.

INSTALLATION (1600-1650)

1. Position steering gear assembly in place and secure with retaining bolts. Figs. 2.1 & 2.2.
 2. Connect hydraulic cylinder bracket to frame with retaining bolts. Fig. 2.2.
 3. Install instrument panel in place and secure with retaining screws.
 4. Reconnect wires to ignition switch, PTO switch and ammeter. Fig. 2.3.
- NOTE:** Green wire connects to (plus) side of ammeter and red wire to (minus) side.
5. Install steering wheel and fuel tank.
 6. Install side shields and cover over drive shaft.
 7. Connect battery cables.

DISASSEMBLY (1600-1650)

Refer to Fig. 2.4 and proceed as follows:

1. Remove locknut and retaining nut from steering arm and remove arm, felt seal and retainer.
2. Remove adjusting nut and slide shaft and bearing from housing.
3. Remove upper bearing from housing.



FIG. 2.1 — STEERING GEAR LOCATION

1. STEERING GEAR RETAINING BOLTS.
2. HYDRAULIC CYLINDER BRACKET.

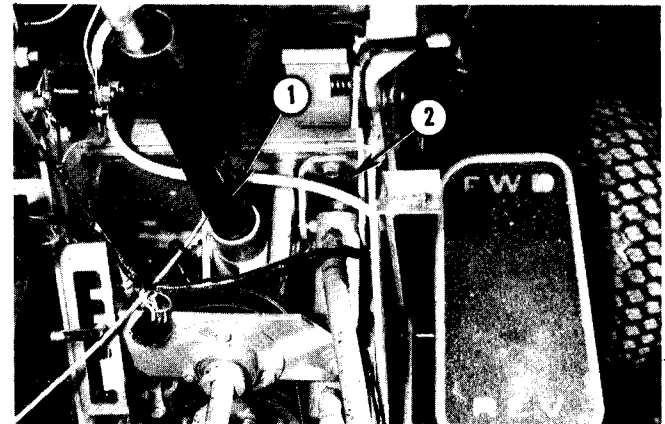

FIG. 2.2 — HYDRAULIC CYLINDER LOCATION

1. STEERING GEAR HOUSING (1600-1650).
2. HYDRAULIC CYLINDER BRACKET.

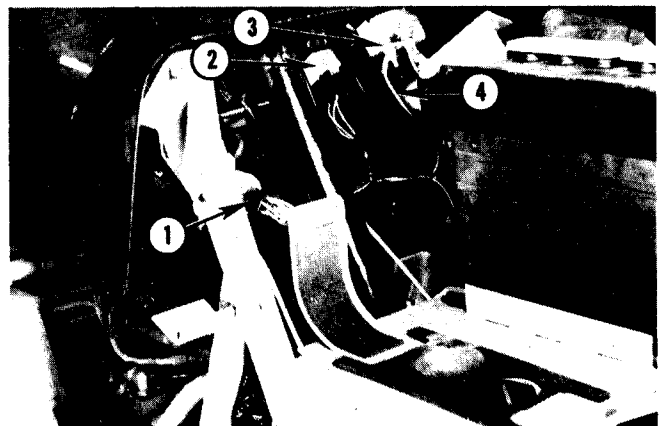
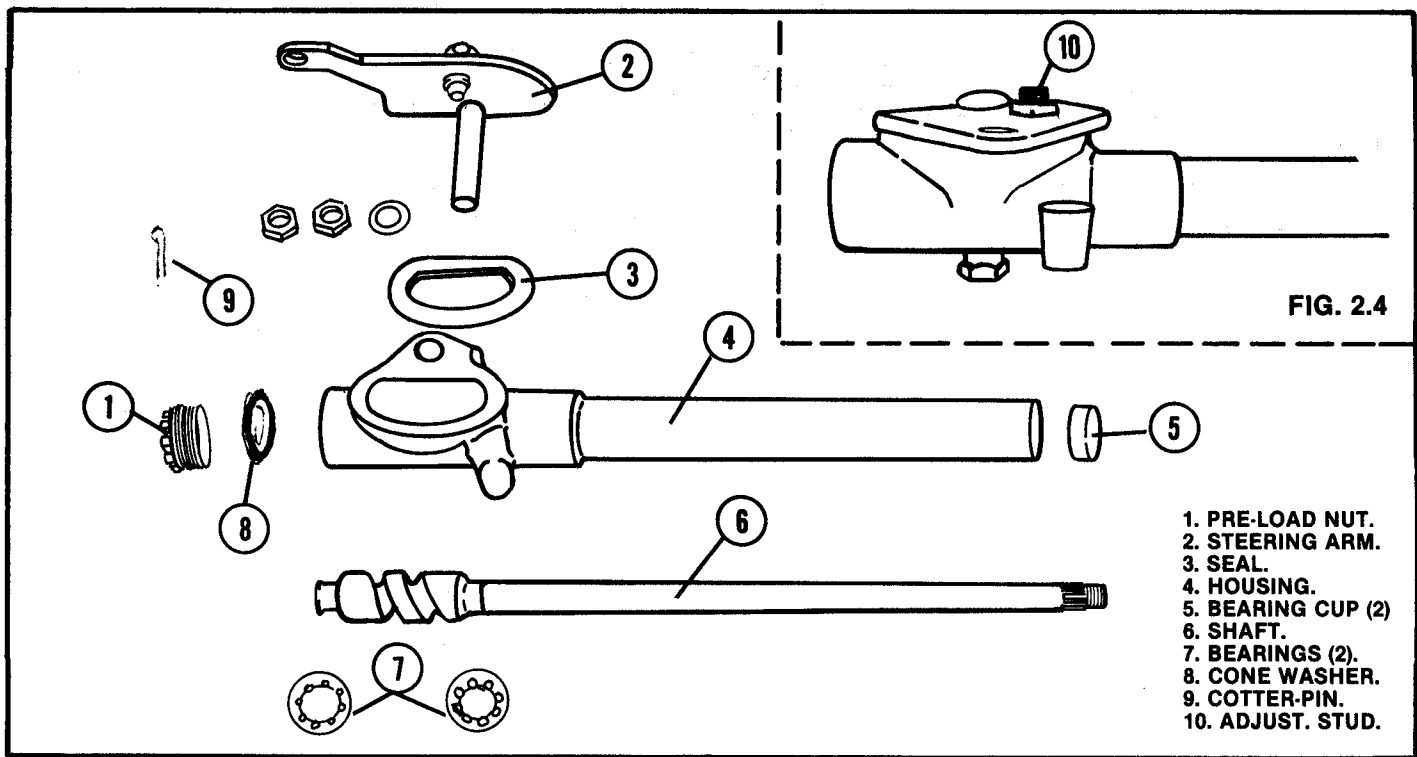

FIG. 2.3 — INSTRUMENT PANEL DISCONNECT

1. IGNITION SWITCH. 2. PTO SWITCH.
3. AMMETER NEGATIVE. 4. AMMETER POSITIVE.



1. PRE-LOAD NUT.
2. STEERING ARM.
3. SEAL.
4. HOUSING.
5. BEARING CUP (2)
6. SHAFT.
7. BEARINGS (2).
8. CONE WASHER.
9. COTTER-PIN.
10. ADJUST. STUD.

2.5—GEAR COMPONENTS

REASSEMBLY (1600-1650)

Refer to Fig. 2.5 for identification of parts and proceed as follows:

1. Lubricate bearings and insert one cup and bearing into gear housing.
2. Slide steering shaft into gear housing, followed with another bearing cone and cup.
3. Install adjusting nut and tighten until steering shaft has a slight bind when turned, Fig. 2.6. At this point adjust nut until shaft has no end-play with no binding when turned. Secure adjusting nut with cotter key.
4. Install bearing at upper end of shaft and tube.

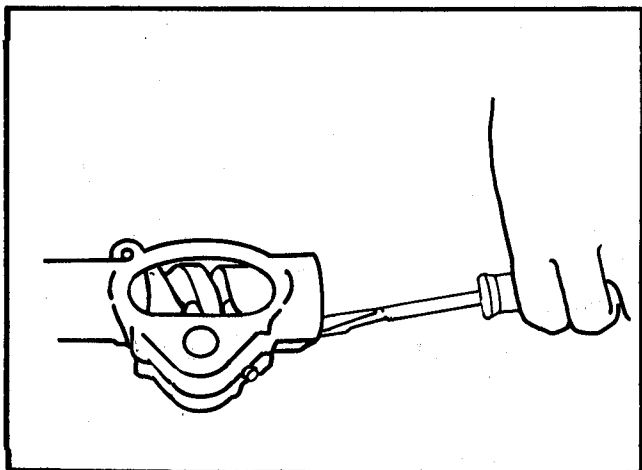

FIG. 2.6 -- SHAFT PRE—LOAD SETTING

5. Loosen adjusting screw in steering arm and install arm into housing with seal and retainer in place.

6. Install washer and one retaining nut on steering arm shaft. Tighten nut until steering arm has no binding or end-play. Secure retaining nut in this position with locknut.

7. Turn in on adjusting screw until a slight drag is felt on steering shaft at mid range of steering (this would be a straight ahead position of front wheels).

8. Back out adjusting screw to eliminate any binding of steering shaft and secure in this position with locknut, Fig. 2.7

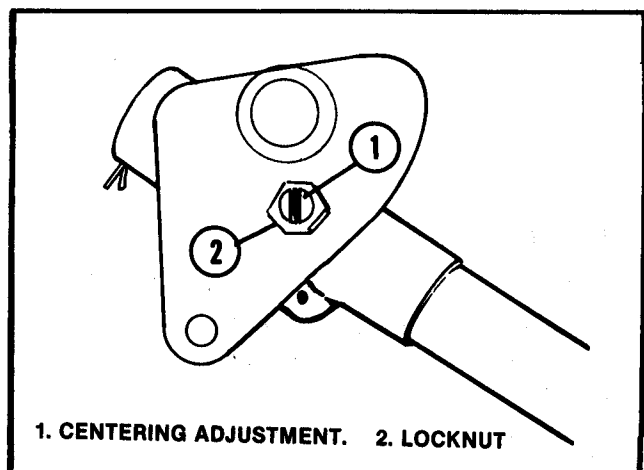

1. CENTERING ADJUSTMENT. 2. LOCKNUT

FIG. 2.7 -- STEERING GEAR ADJUSTMENT

FRONT AXLE AND LINKAGE (1600-1650)

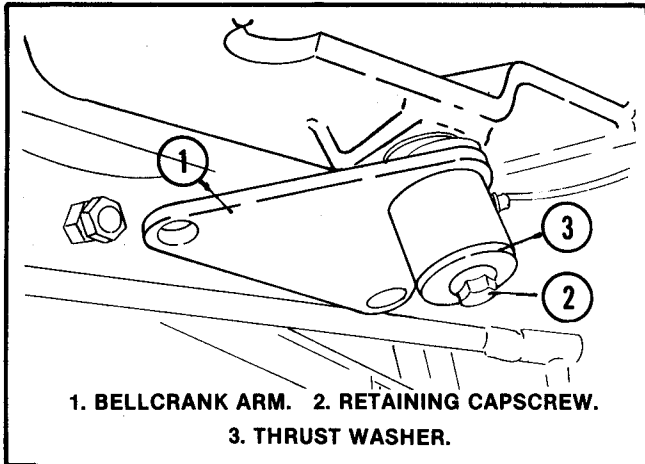

FIG. 2.8 — STEERING BELLCRANK DETAIL

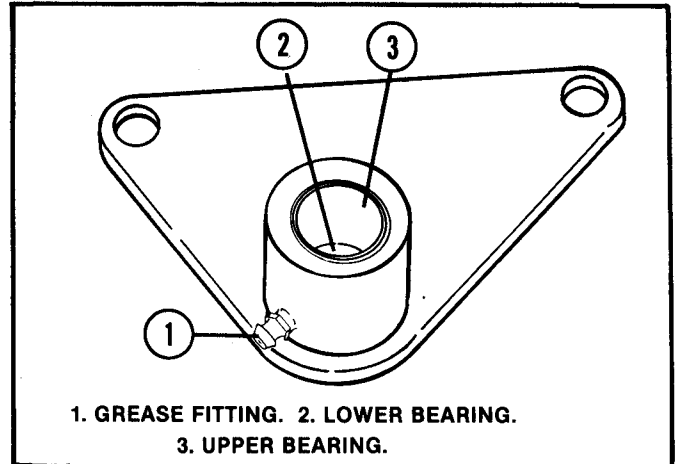

FIG. 2.9 — BELLCRANK BEARINGS IN PLACE

STEERING LINKAGE

The steering linkage consist of a drag link, bellcrank arm assembly and two tie rods. Check all connections and pivot points for looseness. Tie rod and drag link ends are ball socket type and are replaceable. Bellcrank arm has two replaceable bearings.

BELLCRANK ARM AND BEARING REPLACEMENT

1. Disconnect drag links from bellcrank.
2. Remove retaining bolt and slide bellcrank off Fig. 2.8.
3. Remove old bearings and install new bearings flush with outside surface Fig. 2.9.
4. Install bellcrank and secure with retaining bolt, Fig. 2.8.
5. Connect drag links.

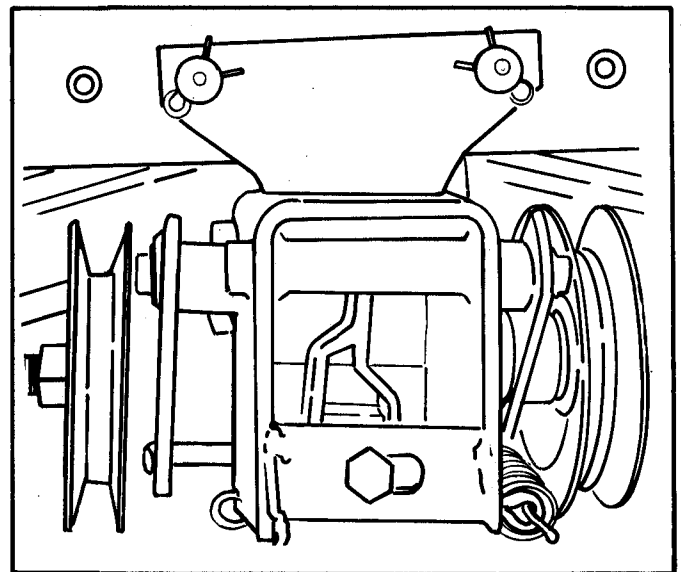

FIG. 2.10 — MOWER "MULE" DRIVE

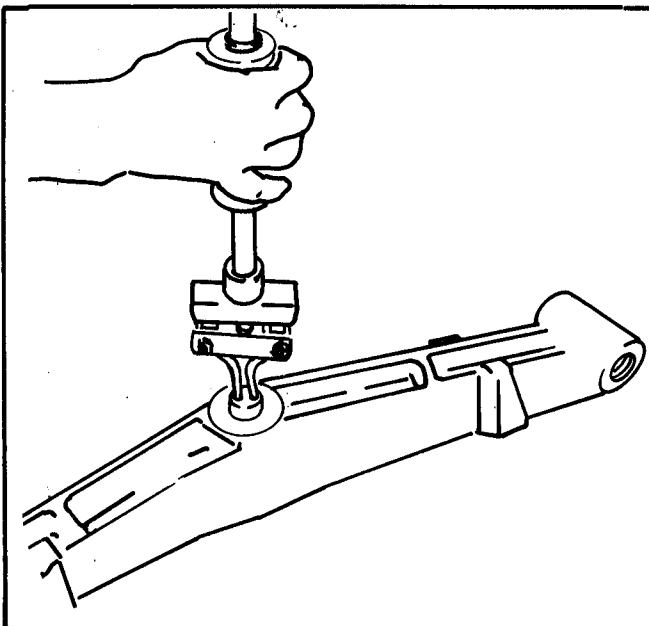

FIG. 2.11 — REMOVING AXLE PIVOT BUSHING

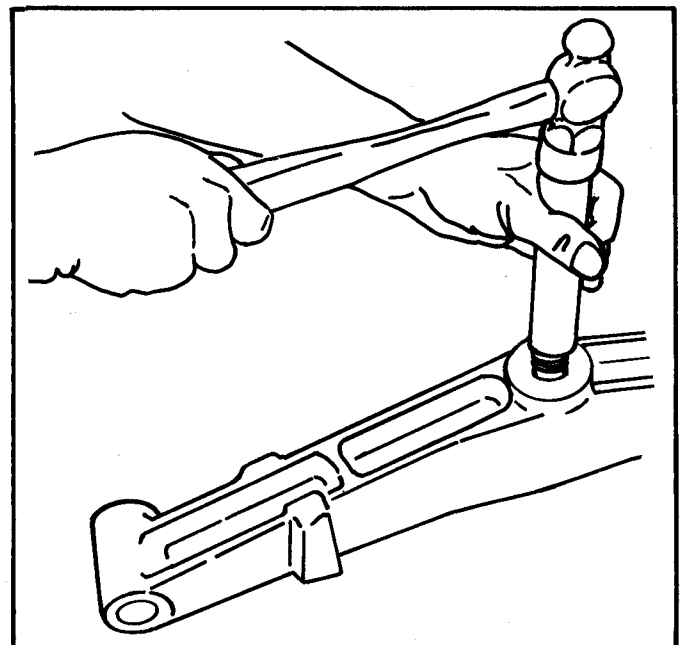

FIG. 2.12 — INSTALLING PIVOT BUSHINGS

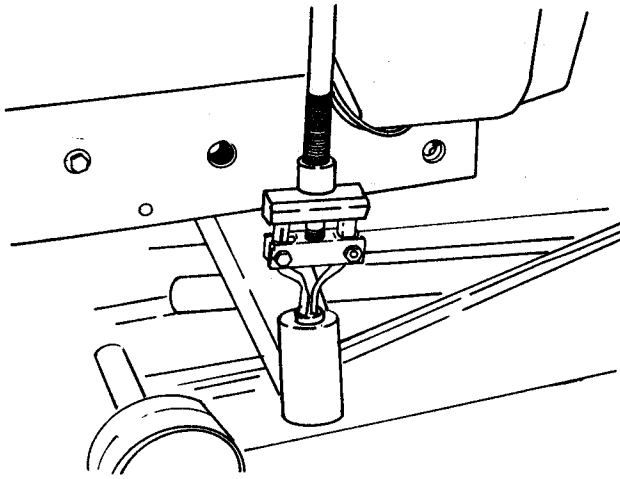

FIG. 2.13 — REMOVING SPINDLE BUSHINGS

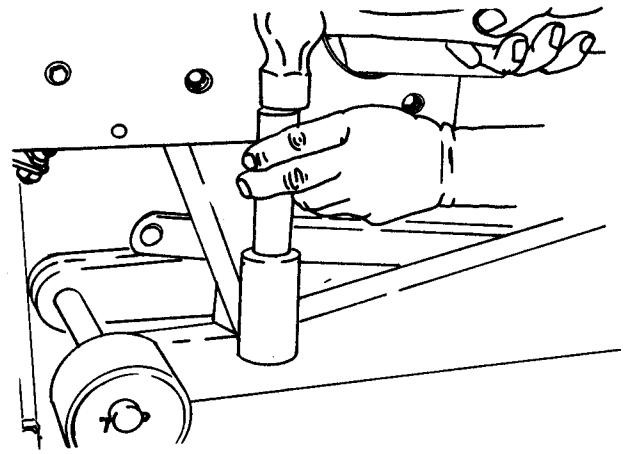

FIG. 2.14 — INSTALLING SPINDLE BUSHINGS

AXLE PIVOT BUSHING REPLACEMENT

1. Remove mower drive idler at front of tractor. Fig. 2.10.
2. Remove wheels and spindles.
3. Remove nut at rear on retaining bolt and remove bolt.
4. Lower axle and remove pivot pin.
5. Remove bushings from axle. Fig. 2.11.
6. Install new bushings, Fig. 2.13.
7. Reinstall axle onto tractor.

SPINDLE ARM BUSHING REPLACEMENT

1. Disconnect tie rod from spindle arm.
2. Remove retaining ring at upper end of spindle and remove spindle.
3. Remove spindle bushings. Fig. 2.13
4. Install new bushings, Fig. 2.14.
5. Reinstall spindle arm and connect tie rod.

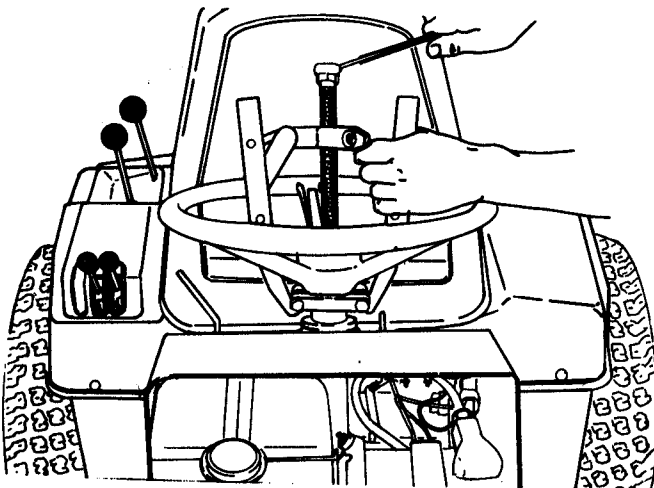

FIG. 2.15 — USE PULLER TO REMOVE WHEEL

WHEEL BEARING REPLACEMENT (1600-1650)

1. Remove wheel and drive bearings out from inside of wheel with a suitable punch.
2. Install bearings with flange of bearing against outside of wheel hub.
3. Reinstall wheel on axle and secure with retaining bolt.

CHECKING AND ADJUSTING TOE-IN (1600-1650)

- Before adjusting toe-in, be sure tie rods are of equal length.
- Adjust toe-in so the distance between front of wheels measure $1/8''$ less than at back.

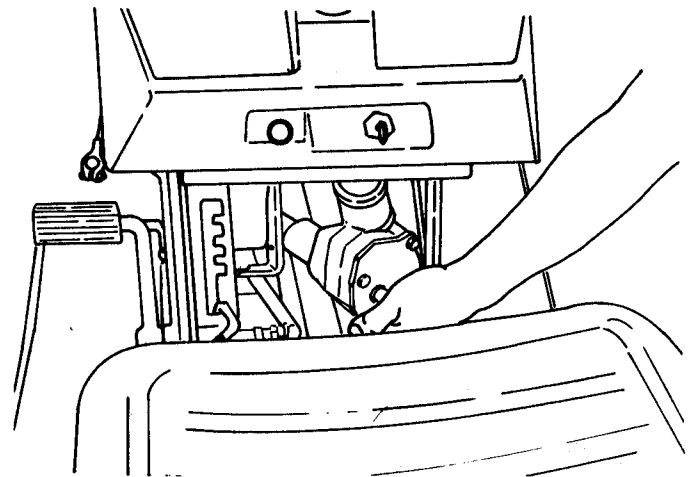

FIG. 2.16 — REINSTALLING STEERING GEAR

1855 SERIES STEERING, FRONT AXLE AND FRONT PTO

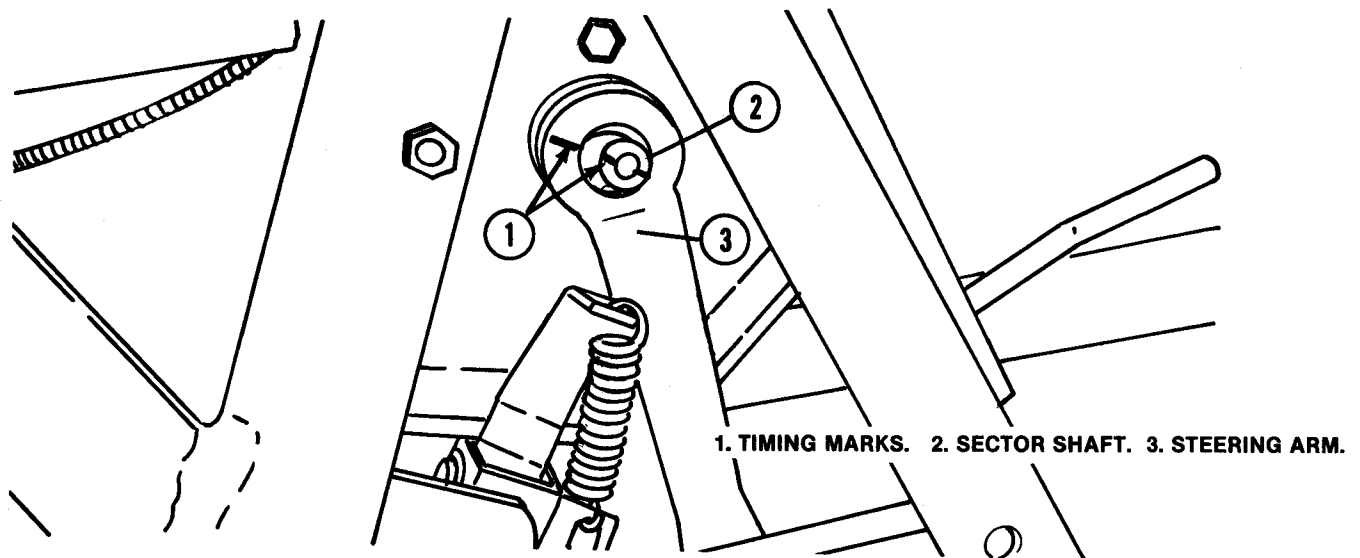

FIG. 2.17 — STEERING ARM LOCATION ON 1855 SERIES
STEERING GEAR ASSEMBLY (1855)

REMOVAL (1855)

1. Disconnect battery and remove wire connector from ignition switch.
2. Use a suitable pulley and remove steering wheel, Fig. 2.15.
3. Remove panel over drive shaft and side panels on each side of tractor.
4. Disconnect drag link and remove arm from steering sector shaft.
5. Remove bolts securing instrument panel in place.
6. Remove bolts securing steering gear and work assembly down and out toward right side of tractor. Fig. 2.16.

INSTALLATION (1855)

1. Work steering gear up from right side of tractor and into place as shown in Fig. 2.16.
2. Secure steering gear assembly into place with retaining bolts.
3. Install steering arm while aligning timing marks. Fig. 2.17. And secure with retaining washer and nut.
4. Install bolts securing instrument panel.
5. Install steering wheel, side panels and panel over drive shaft.
6. Install wire terminal on ignition switch and connect battery cables to battery.

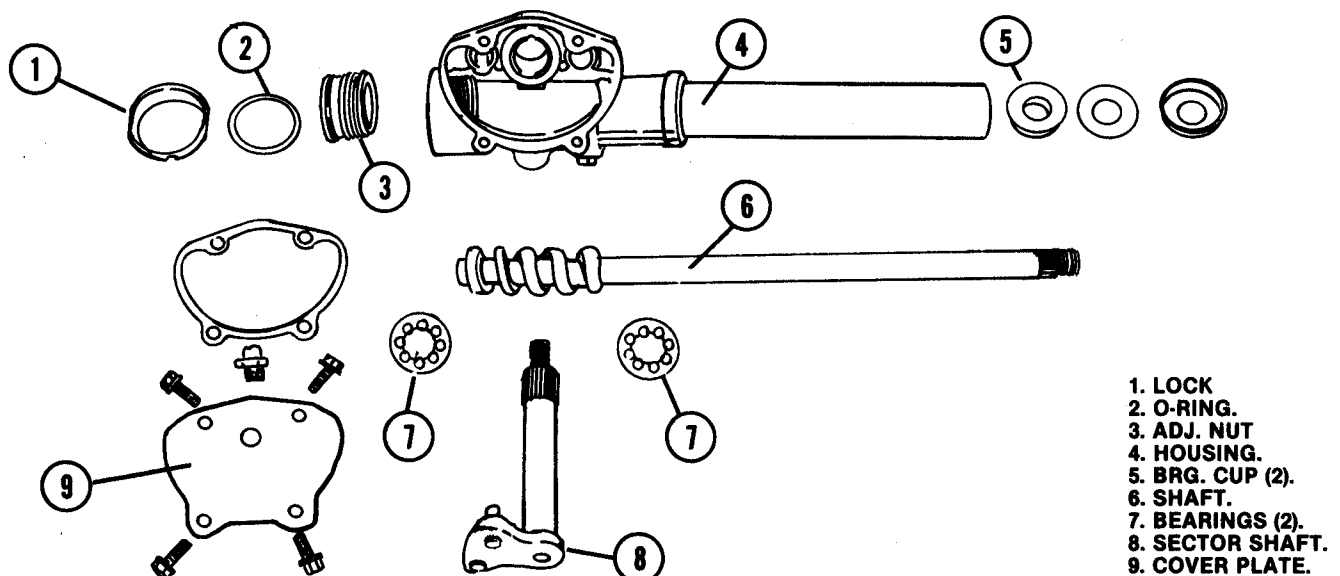

FIG. 2.18 — 1855 SERIES STEERING GEAR COMPONENTS

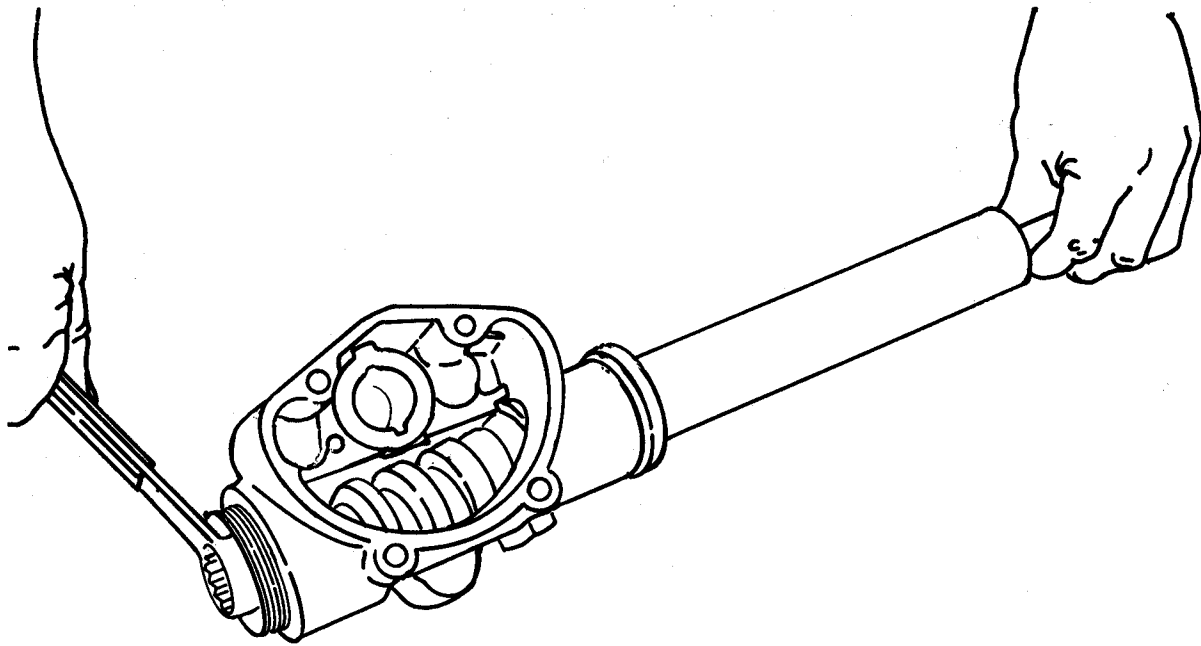

FIG. 2.19 — PRE—LOAD SETTING ON 1855 SHAFT BEARINGS

DISASSEMBLY (1855)

1. Remove capscrews securing plate and remove plate.
2. Slide sector shaft from housing.

REASSEMBLY (1855)

1. Lubricate both bearings and insert one cup and bearing cone into gear housing, followed with another bearing cone and cup.
2. Install adjusting nut and tighten until steering shaft has a slight bind when turned. Fig. 2.19. At this point adjust nut until shaft has no end-play with no binding when turned. Secure adjusting nut with lock.

3. Install bearing, seal and retainer over upper end of shaft and into housing.
4. Fill cavity in housing with a good grade of lithium base grease and install sector shaft.
5. Position gasket and plate over shaft and secure with retaining bolts. Fig. 2.20.
6. Adjust steering gear back lash as follows:
 - a. Turn in on adjusting screw until a slight drag is felt on steering shaft at mid range of steering (this would be a straight ahead position of front wheels)
 - b. Adjust screw by turning in or out to eliminate any binding and secure in this position with lock nut.

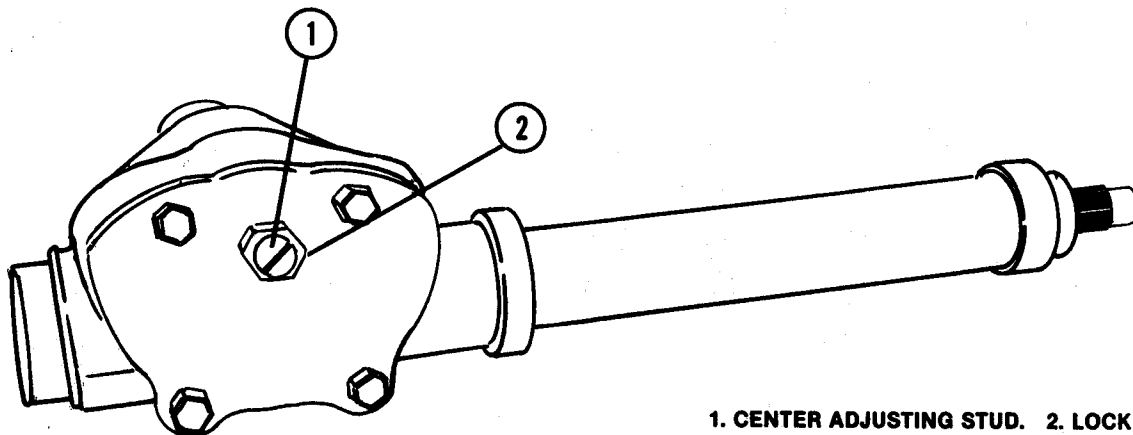

1. CENTER ADJUSTING STUD. 2. LOCKNUT.

FIG. 2.20 — 1855 SERIES STEERING SHAFT ADJUSTMENT

FRONT AXLE AND FRONT PTO (1855)

Front power take-off is part of front axle pivot on the 1855 series therefore servicing of these units are together.

REMOVAL (1855)

1. Remove front pulley shield and remove drive belts.
2. Remove retaining ring and remove pulley. Fig. 2.21.
3. Unscrew large nut and bearing assembly off axle mounting sleeve and slide off. Fig. 2.22.
4. Remove retaining ring from shaft. Fig. 2.23.
5. Remove large nut from rear of axle mounting sleeve and slide PTO shaft with nut and bearing out rearward. Fig. 2.24.

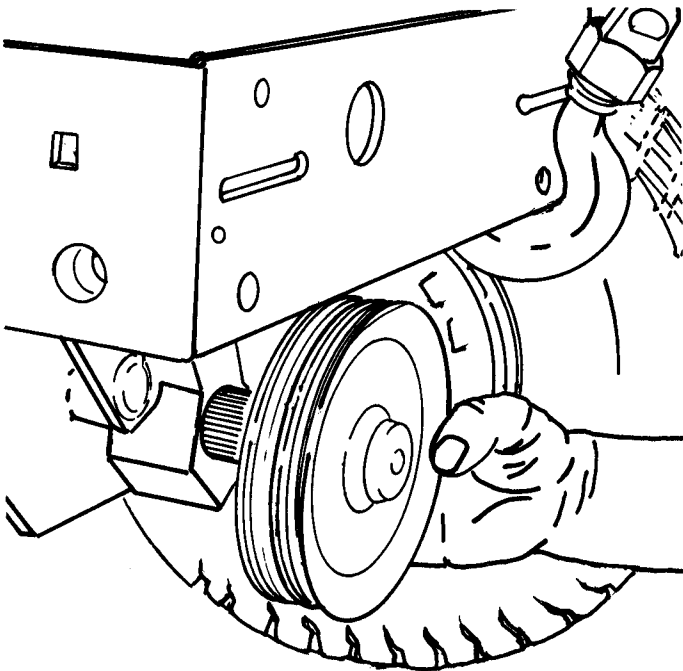

FIG. 2.21 — REMOVING FRONT PULLEY

6. Disconnect drag link from steering pivot and attach a suitable lifting device to raise tractor.

7. Raise tractor enough to remove pressure on axle and remove mounting sleeve. Fig. 2.25.

8. Continue raising tractor and remove axle, thrust washers and pivot tube. Fig. 2.26.

9. Inspect bushings if worn, remove old bushings and install new ones flush with machined surface of axle. Fig. 2.27.

10. Install bushings in bellcrank arm flush with machined surface. Fig. 2.28.

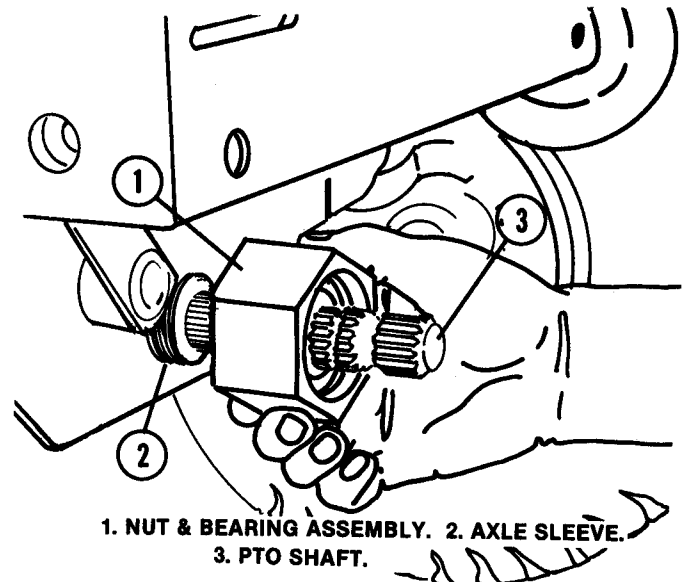

FIG. 2.22 — FRONT PTO BEARING PARTS

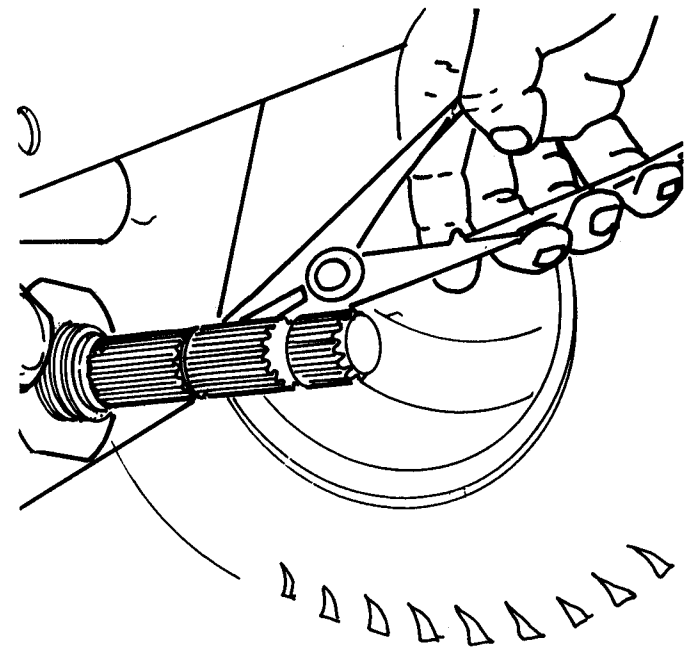

FIG. 2.23 — REMOVING RETAINING RING

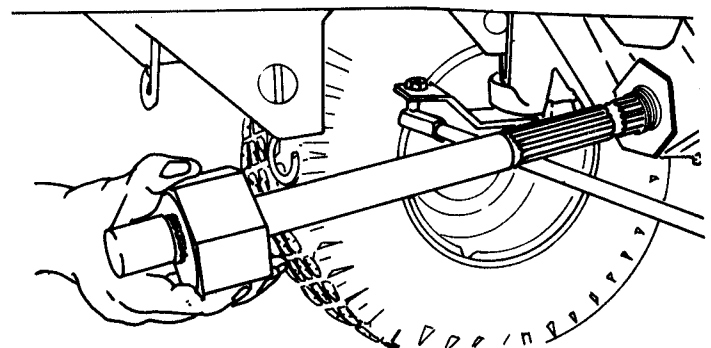
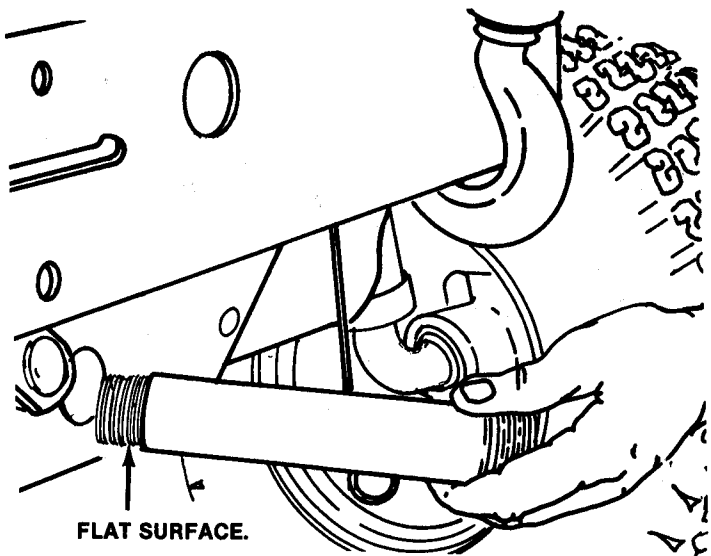

FIG. 2.24 — PULLING FRONT PTO SHAFT



FLAT SURFACE.

FIG. 2.25 — REMOVING FRONT AXLE

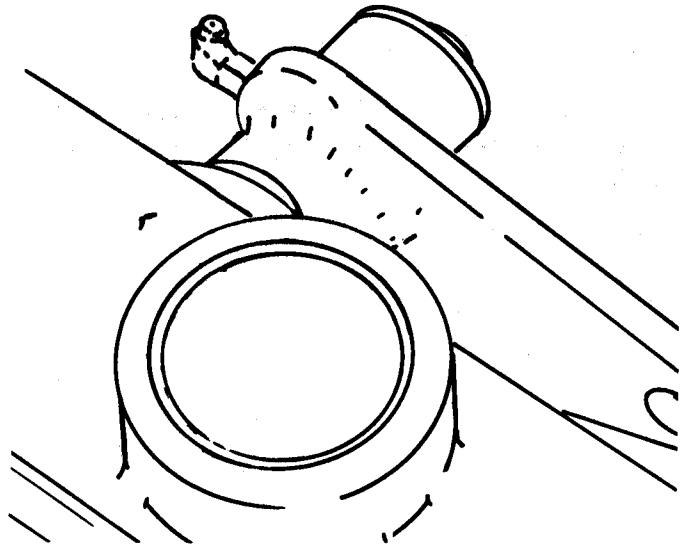

FIG. 2.27 — PIVOT BUSHING IN PLACE

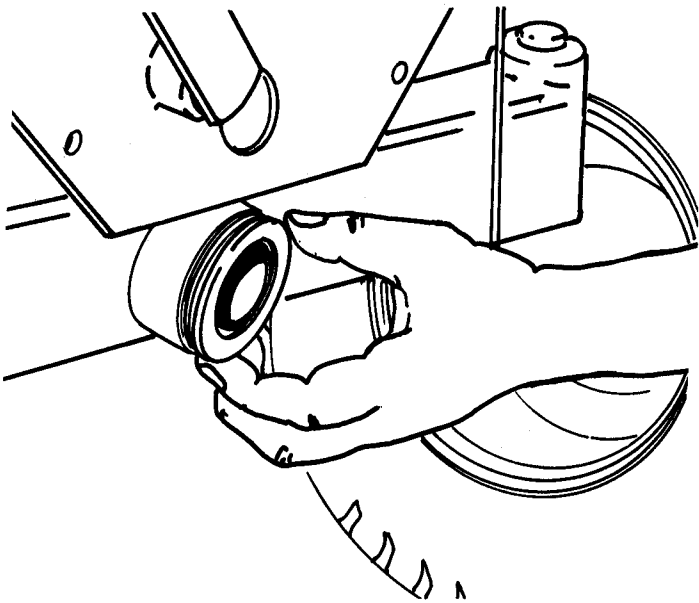

FIG. 2.26 — THRUST WASHER & PIVOT TUBE

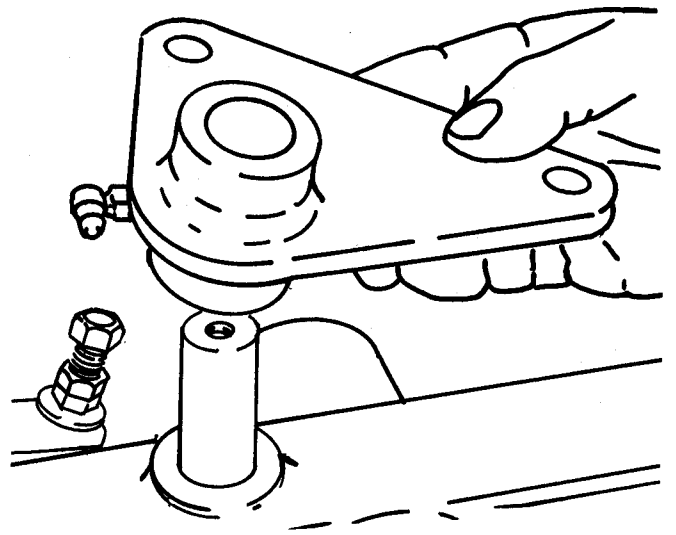

FIG. 2.28 — REMOVING BELLCRANK

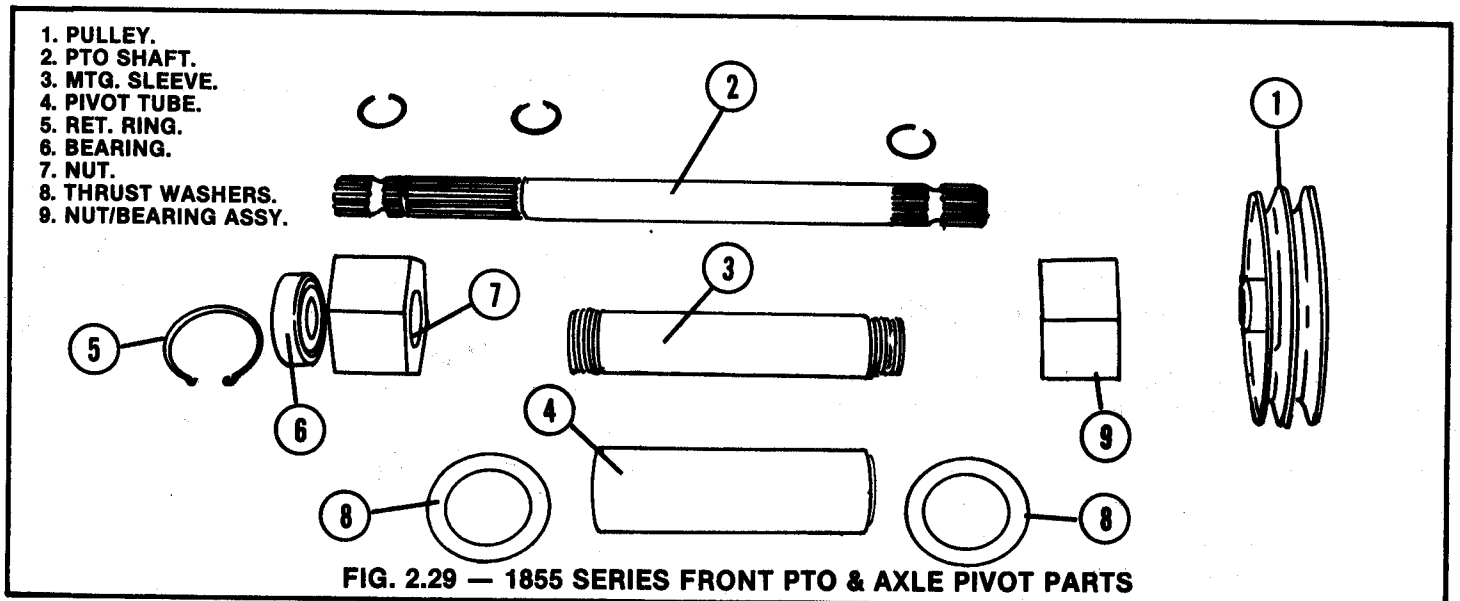

FIG. 2.29 — 1855 SERIES FRONT PTO & AXLE PIVOT PARTS

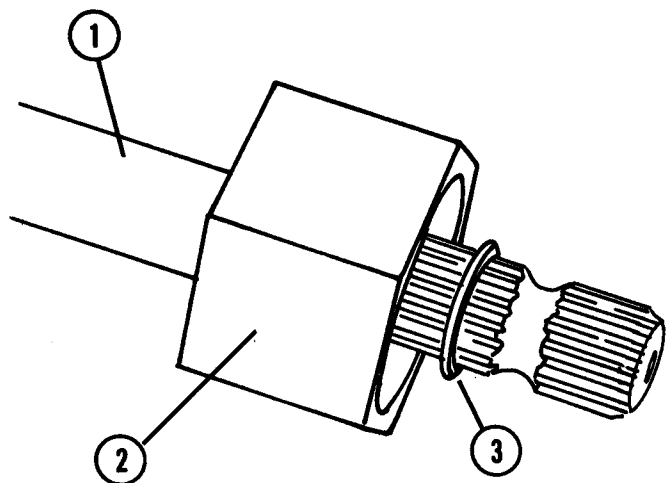

FIG. 2.30 — PTO REAR NUT & BEARING

1. PTO SHAFT.
2. NUT & BEARING ASSEMBLY.
3. RETAINING RING.

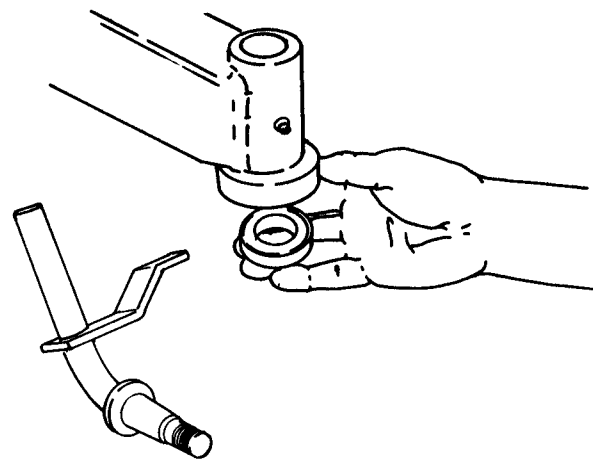

FIG. 2.32 — LOWER SPINDLE BUSHING

INSTALLATION (1855)

1. Place pivot tube in axle and position thrust washers on end of tube. Fig. 2.30.

2. Lower tractor over axle pivot tube and thrust washers as shown in Fig. 2.26.

3. Install axle mounting sleeve with flat on sleeve down and rearward. Fig. 2.25.

4. Install rear nut and bearing assembly on PTO shaft and install retaining ring in groove on shaft. Fig. 2.30.

5. Install shaft into axle mounting tube at rear. Fig. 2.24.

6. Secure shaft in place by turning nut and bearing onto threaded end of axle mounting tube.

7. Position shaft so retaining ring can be installed at front. Fig. 2.31.

8. Install nut and bearing over front end of PTO shaft and tighten both large nuts securely.

9. Install double pulley and secure with retaining ring.

10. Connect drag link to bellcrank and tighten nut securely.

SPINDLE ARM BUSHING REPLACEMENT (1855 SERIES)

1. Remove wheel and disconnect tie rod from spindle arm.

2. Remove retaining ring at upper end of spindle and remove spindle.

3. Remove upper bushing and reinstall new one flush with machined surface of axle.

4. Drive lower bearing out and reinstall new. Figs. 2.32 and 2.33.

5. Reinstall spindle, connect tie rod and install wheel.

1. DOUBLE PULLEY.
2. RETAINING RING.
3. PTO SHAFT.

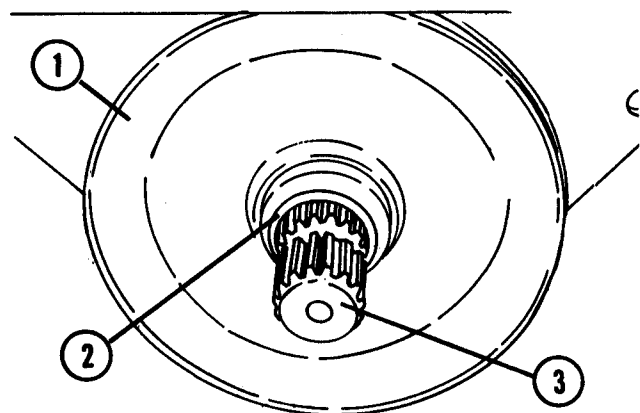

FIG. 2.31 — FRONT PULLEY REINSTALLER

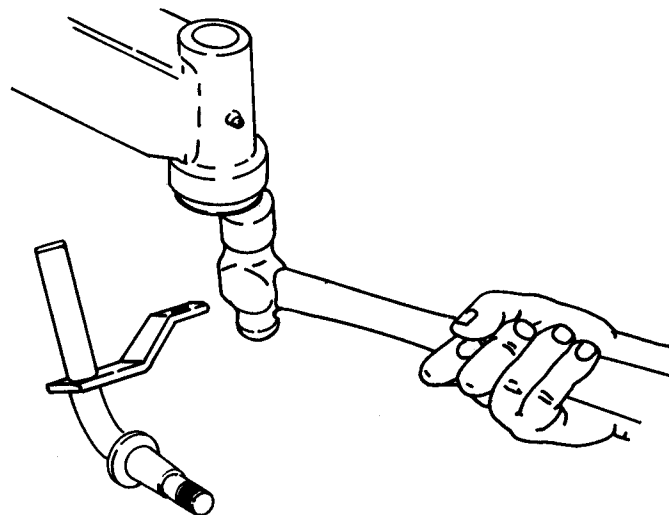

FIG. 2.33 — INSTALLING LOWER SPINDLE BUSHING

WHEEL BEARING REPLACEMENT (1855)

1. Remove wheel and clean bearings with a suitable solvent. Remove old grease from inside of hub.

2. Inspect bearings and seals for wear. Replace as required.

3. Pack each bearing with Lithium Base grease. Install inner bearing in wheel and install new seal with lip of seal toward bearing.

4. Pack grease between lips of seal and bearing.

5. Install wheel on spindle and tighten retaining nut 15-20 ft. lbs. while rotating wheel.

6. Install retainer on nut so that castellations are aligned with cotter pin hole.

7. Back off nut and retainer one castellation and secure with cotter pin.

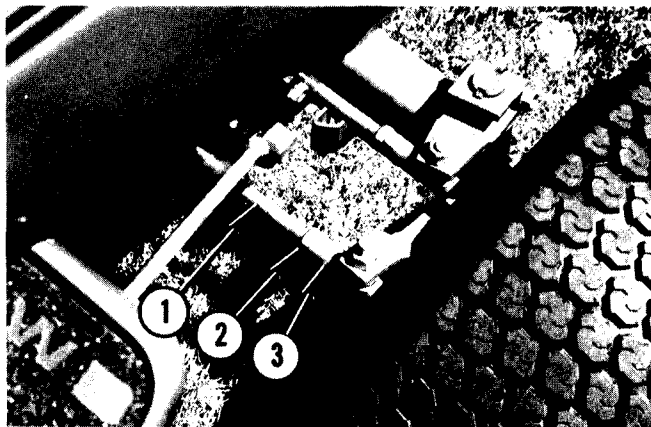
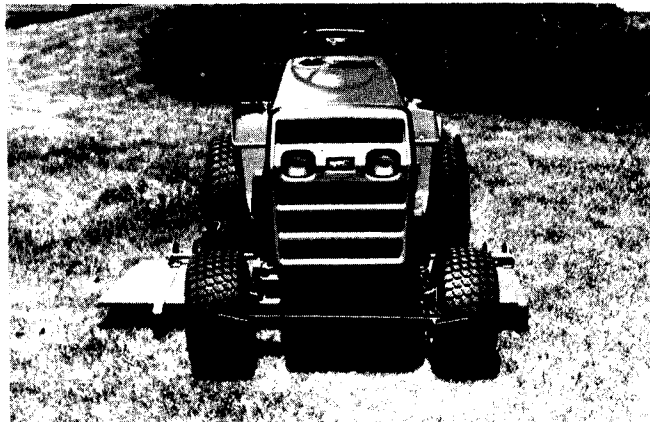

CHECKING AND ADJUSTING TOE-IN (1855)

Adjust toe-in so the distance between front of wheels measure $1/8$ " less than at back. Adjust by loosening tie rod lock nuts and turning tie rod.

FIG. 2.34 -- 1855 SERIES TOE-IN SETTING

1. TIE-ROD. 2. LOCKNUT. 3. BALL JOINT.

SECTION 3 - BRAKES & HYDROSTATIC DRIVE CONTROLS

On the 1600 series tractors, braking is provided by left pedal activated brake band which clamps around a drum on the transaxle to brake the tractor. The adjustment and service procedure for the 1600 series is covered on pages 3.5 and 3.6. On tractors with hydrostatic drive, braking action is provided by the forward/reverse pedal activated drive system when the engine is running and by the left pedal operated disc brake mechanism when the engine is off. This also serves as a parking brake when engaged by the parking brake-speed selector lever. Brake service on the hydrostatic drive equipped 1650 and 1855 series tractor is covered in first part of this section.

BRAKE SERVICE

To gain access for brake service, it will be necessary to remove the center console, left side panel and the rear fender-seat assembly. To do this, remove the control knobs. The console is secured to the frame with four phillips head screws. The left side panel is attached to the frame with three flange lock bolts which are turned into locknuts on the inside of the frame. To remove the fender-seat assembly, disconnect the tail light and seat interlock leads, slide the seat full forward and remove the two bolts at rear of the seat rails then remove the four carriage bolts holding the fender to the step plates and lift the fender/seat off the tractor. Use kit #6-0538 for brake repairs on hydrostatic drive tractors.

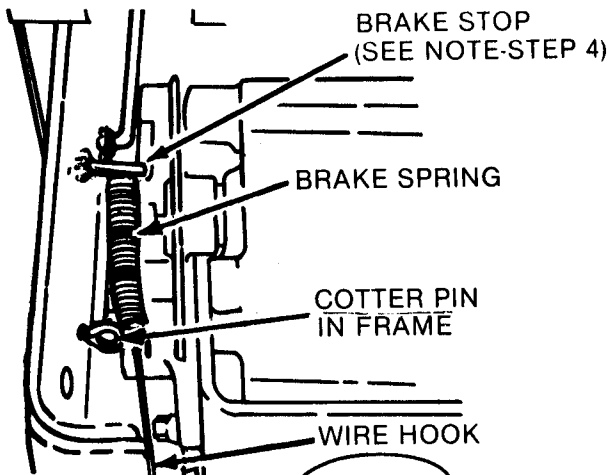

FIG. 3.1--BRAKE SPRING & STOP DETAIL

1. Block front wheels and jack rear of tractor up and remove the left rear wheel.
2. Disconnect the brake spring from the cotter pin in tractor frame (Figure 3.1).
3. Remove the two bolts that hold the brake assembly to the transmission (Figure 3.2).
4. Pull the brake disc toward the outside and remove the inside brake pad from behind the disc. Inspect the brake disc surface condition. Replace disc if badly warped, scored or pitted.

NOTE: If the brake disc has to be replaced, it will be necessary to saw 3/8" off the end of the brake stop stud which is welded to the frame directly behind the brake actuating arm as shown in figure 3.1. The brake assembly also has to be removed. This requires the large access hole shown in figure 3.2.

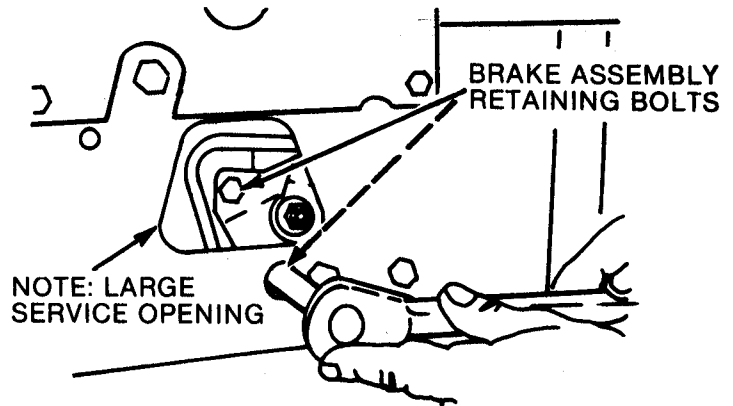

FIG. 3.2--BRAKE ASSEMBLY REMOVAL

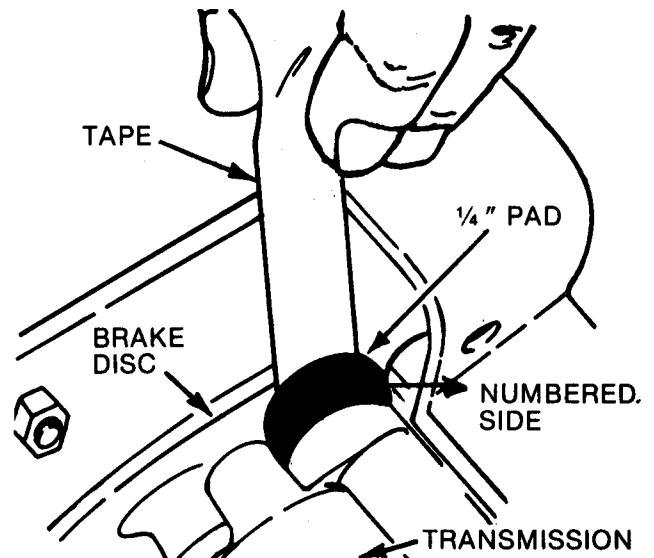

FIG. 3.3--BRAKE DISC INSTALLATION

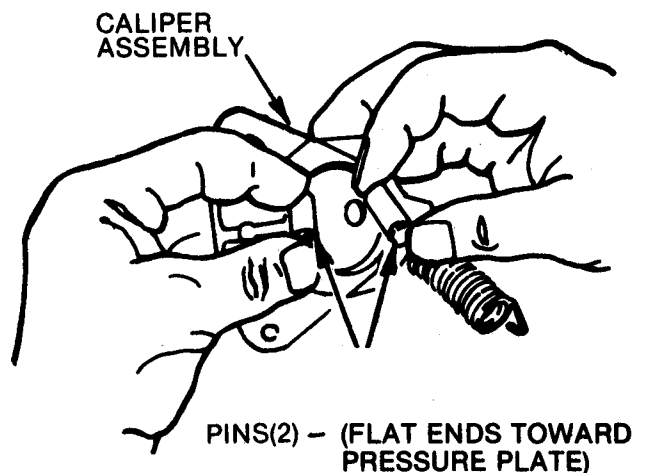

FIG. 3.4--INSPECT CALIPER PINS

5. Apply a small amount of non-hardening adhesive to the numbered side of the 1/4 inch pad from kit to secure the pad in the transmission. Use a strip of duct tape about 12 inches long to suspend the new 1/4 inch pad behind the disc and position the pad into the recess in the transmission case (Figure 3.3). Push the disc in toward the transmission to hold the pad in position then remove the tape. Inspect to make sure there is not tape left on the pad that will interfere with later adjustments.
6. Remove the 1/2 inch brake pad from the brake caliper assembly and inspect the caliper assembly to make sure that the pins move freely and that actuator linkage has adequate freedom of movement for positive braking operation (Figure 3.4). Make sure flat end of pins are installed toward the pressure plate. NOTE: If pins do not move freely, remove and clean before proceeding further. Lubricate the pins with dry graphite.
7. Insert the metal pressure plate into the brake assembly then install the new 1/2 inch brake pad with numbers facing away from the brake disc (Figure 3.5). Position the brake assembly on the transmission and reinstall the mounting bolts.
8. Reconnect the brake spring to the cotter pin in tractor frame (Figure 3.1).

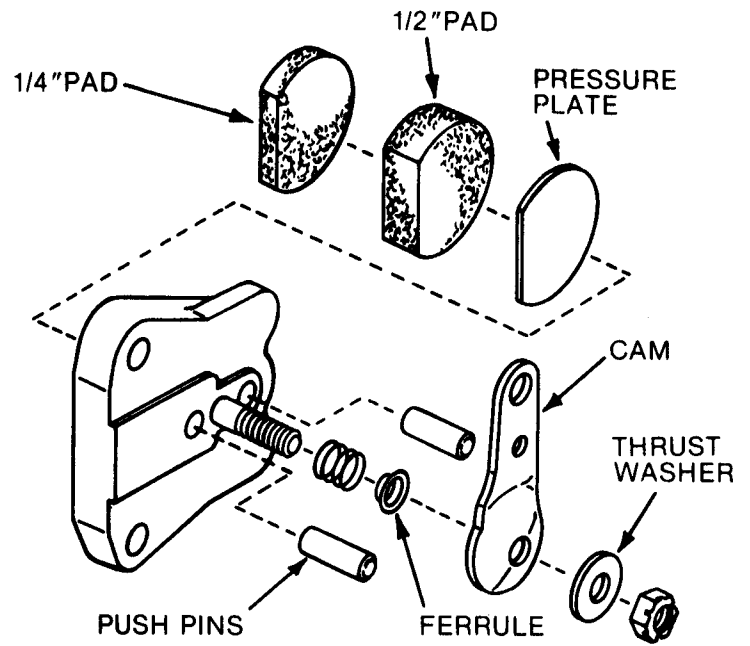
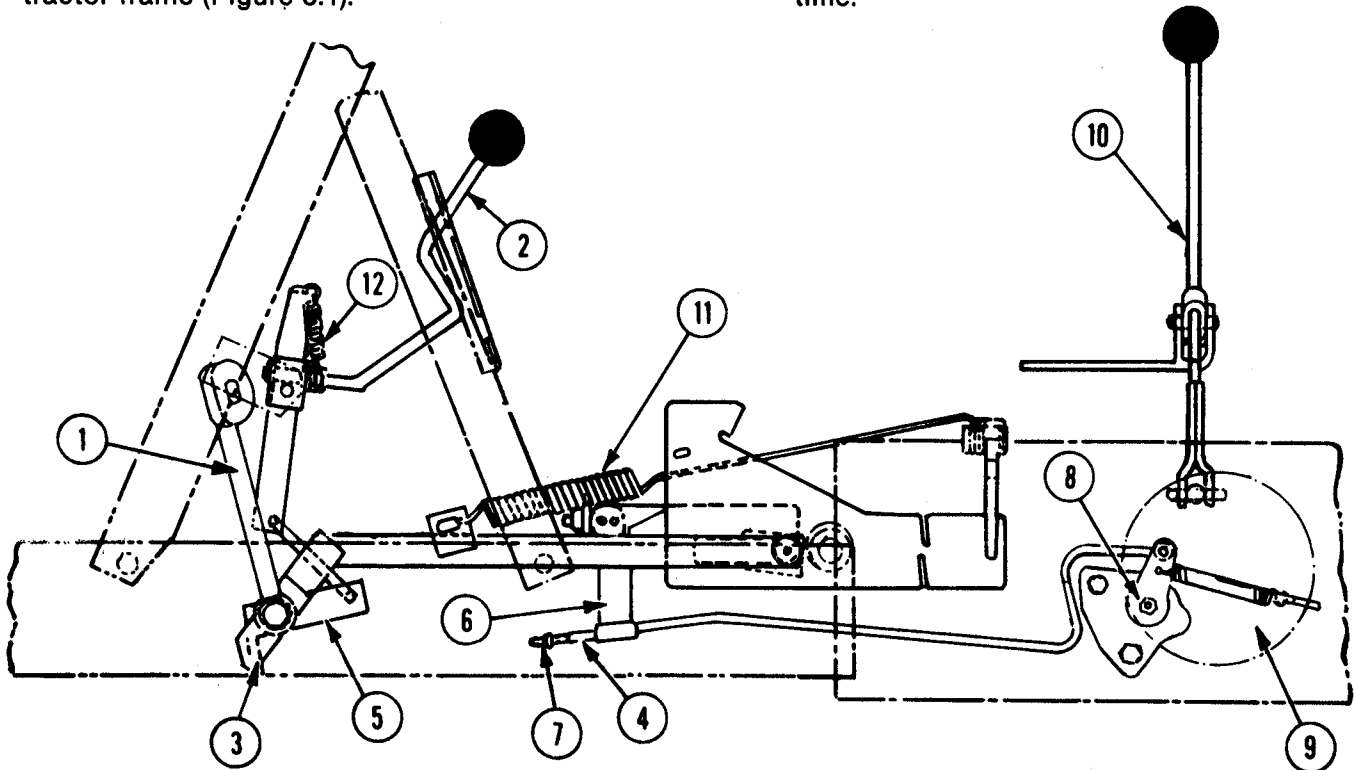

FIG. 3.5--BRAKE COMPONENT SEQUENCE

9. Remove the nut from the brake adjusting stud and install the slotted nut from kit in its place (Figure 3.8). Do not install cotter pin at this time.



- | | | |
|------------------------|---------------------|-----------------------|
| 1. PARKING PEDAL | 5. PEDAL LINK SHAFT | 9. BRAKE DISC |
| 2. PARKING BRAKE LEVER | 6. ENGAGING SLEEVE | 10. HI-LO SHIFT LEVER |
| 3. ADJUSTER LINK | 7. BRAKE ROD NUT | 11. RETURN SPRING |
| 4. BRAKE ROD | 8. BRAKE ASSEMBLY | 12. PARK LEVER SPRING |

FIG. 3.6--LOCATION OF BRAKING SYSTEM COMPONENTS (HYDROSTATIC DRIVE UNITS)

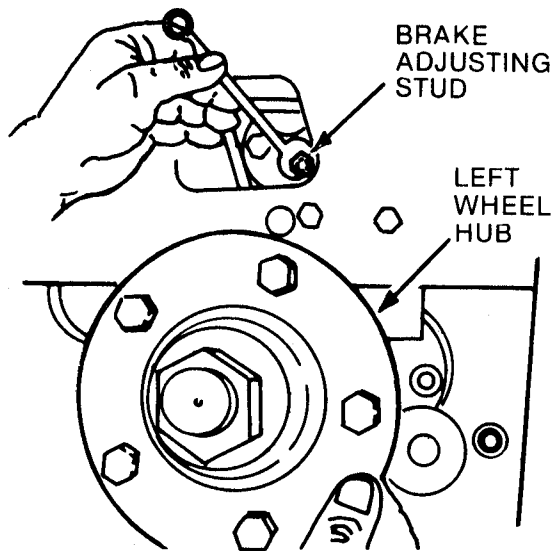

FIG. 3.7--BRAKE ADJUSTMENT PROCEDURE

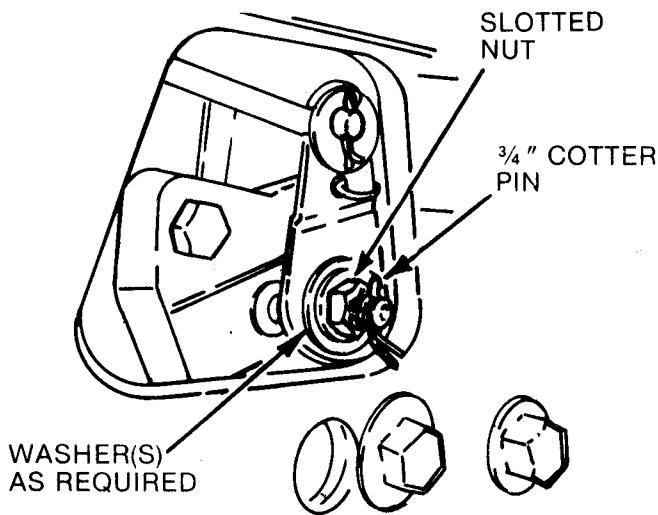

FIG. 3.8--ADD SPACER WASHERS AS REQUIRED

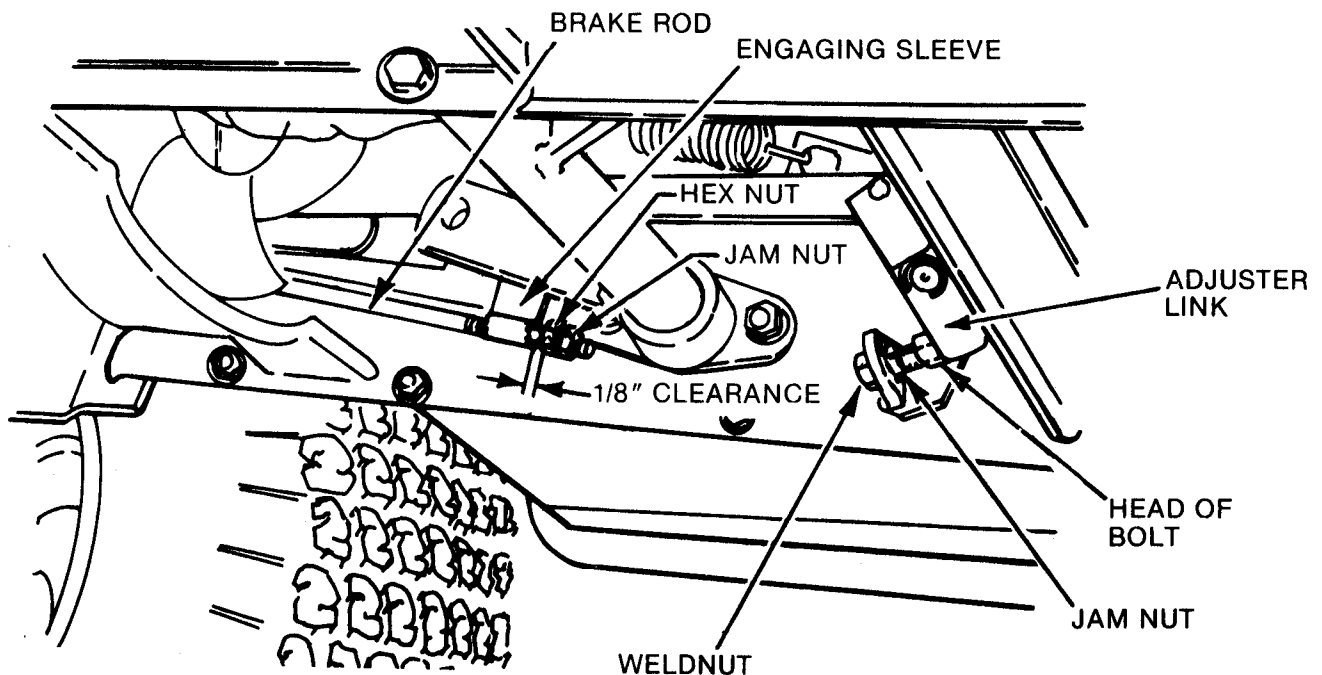

FIG. 3.9--BRAKE ENGAGING SLEEVE CLEARANCE ADJUSTMENT

BRAKE ADJUSTMENT PROCEDURE

1. Inspect the brake rod and make sure the cotter pin is secure in the end of the rod. Back the nut on the brake rod (Figure 3.6-item 7) to the end of the rod and shift the parking brake shift lever (Figure 3.6-item 2) out of park. Next, place the HI-LO shift lever in neutral.
2. With the right wheel on the ground or otherwise secured to prevent rotation, turn the left rear wheel hub while tightening the nut on the brake adjusting stud until the wheel hub can no longer be turned (Figure 3.7). This achieves zero clearance between the brake pads and the disc. Now, back off on the adjusting nut 1/2 turn and secure the nut with a 3/32x3/4 cotter pin through the hole in the adjusting stud then bend the cotter pin to secure (Figure 3.8).

NOTE: It may be necessary to add washers (provided in kit) behind the adjusting nut to insure that the cotter pin is securely engaged in the slot of the nut.

3. All tractors shipped after November, 1980 have heat treated parking brake levers (item 2, Figure 3.6). If the tractor involved does not have a heat treated lever or if there is any doubt whether it is heat treated, replace the lever with the one provided in brake kit. To replace, disconnect the park lever spring, remove the cotter pin or retaining ring and remove the lever. Install the kit lever and secure with 1/8x3/4 cotter pin. Replace the park lever spring.
4. Place the parking brake lever in the park position.

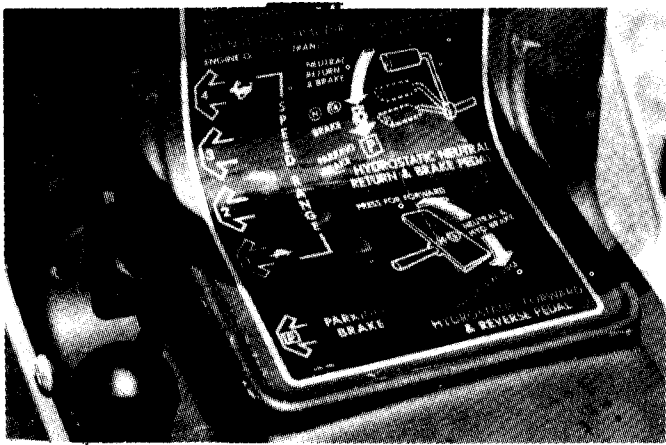

FIG. 3.10--PARKING BRAKE/SPEED SELECTOR

5. Depress the left pedal and hold all the way down. Adjust the selector link adjuster screw (Figure 3.6-item 3) until there is zero clearance between the end of the screw and the selector link.
6. After making the selector link adjustment, if the adjuster screw does not appear to hit squarely against the selector link, it will be necessary to replace the adjuster screw with a 5/16x1-1/4 hex head bolt (Figure 3.9). Loosen the jam nut on the adjuster screw and remove the screw. Install the hex head bolt and jam nut with the head of the bolt toward the selector link to increase the area of contact between the adjustment bolt and the selector link. Make adjustment as previously described and lock jam nut.
7. Place the parking brake brake lever into the first speed notch and tighten the nut on the end of the brake rod until there is 1/8 inch clearance between the nut on the rod and the brake engaging sleeve of the linkage (Figure 3.9). Install and lock a jam nut against the brake rod nut.
8. **TEST BRAKES** by placing tractor on level surface. With engine off, HI-LO shift lever in neutral and parking brake set, attempt to roll tires by pushing tractor. If tires roll, brake must be readjusted.

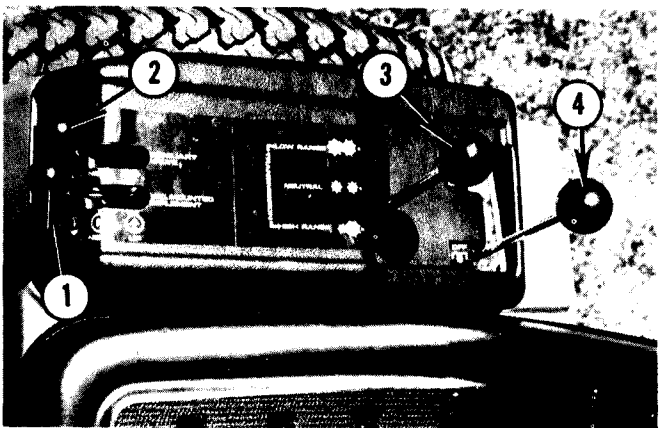

FIG. 3.11--CONTROLS LEVERS LOCATION

1. Mid-Mount. 2. Three Point Hitch.
3. HI-LO Shifter. 4. Rear P.T.O.

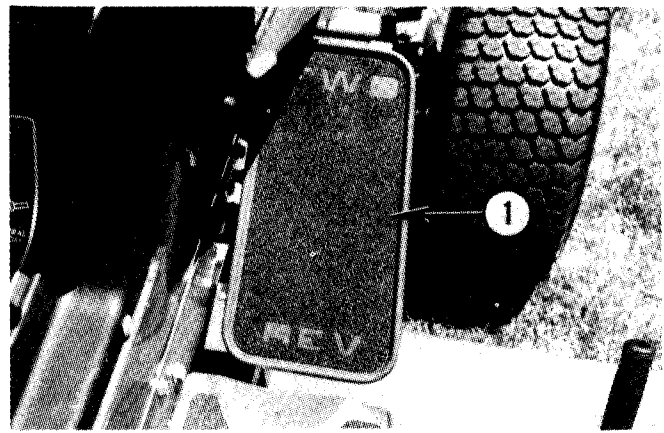

FIG. 3.12--FORWARD/REVERSE PEDAL

HYDROSTATIC DRIVE CONTROL

On tractors with hydrostatic transmission, the forward/reverse pedal on the right side controls the direction of travel. The tractor should move forward when the forward or toe of the foot pushes the pedal down and rearward when the heel pushes the lower part of the pedal down. When the heel or toes are not pressing against the pedal, the tractor should stop and remain stationary provided the engine is running. The Parking brake pedal and lever on left side must be engaged to brake and keep the tractor stationary when the engine is stopped.

Before attempting to adjust the transmission linkage on hydrostatic drive tractors, perform following checks;

1. Start tractor.
2. Place rear axle shift lever in low speed range.
3. Release neutral return and brake pedal.
4. Place right foot on heel and toe pedal.
5. Tilt right foot to rotate toe end of pedal downward. Tractor should travel forward.
6. Remove foot from pedal, tractor should stop and remain stopped.
7. Place right foot on pedal and tilt foot to rotate heel end of pedal downward. Tractor should travel rearward.
8. Remove foot from pedal, tractor should stop and remain stopped.

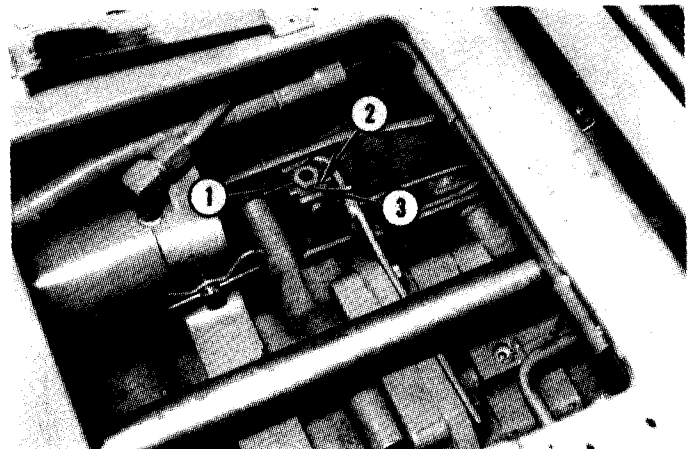

FIG. 3.13--TRANSMISSION SHIFT ADJUSTMENT

1. Adjuster. 2. Retainer. 3. Cotter Pin.

LINKAGE ADJUSTMENTS

1. Block tractor up so that rear wheels are free to rotate.
2. Loosen nut on end of brake rod to end of rod.
3. Place speed control/parking brake lever in park position.
4. Depress clutch/brake pedal down against step plate. Adjust selector link adjuster screw to obtain zero clearance between end of screw and selector link, then tighten jam lock nut.
5. Raise tractor seat and clamp safety switch to hold circuit closed so engine will start.
6. Depress directional control pedal forward and backward to insure no binding occurs in pedal or linkage.

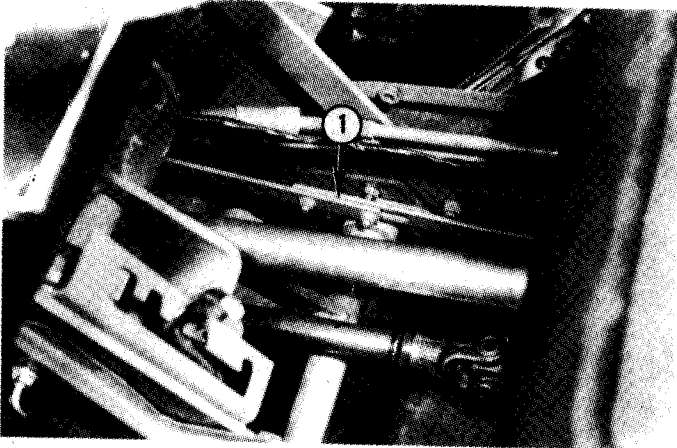

FIG. 3.14--FORWARD/REVERSE PEDAL LINKAGE
1. Linkage Adjustment.

7. Remove cotter pin and retainer from transmission adjuster stud.
8. Start engine, shift speed control lever out of park and axle shift lever in gear.
9. Turn adjuster in one direction until wheels rotate then while counting complete turns of adjuster stud, turn adjuster in opposite direction until wheels rotate in opposite direction. Back up half the number of complete turns counted to place the transmission in a neutral position. The wheels should not rotate in either direction in neutral.
10. Make a final check of adjustments as follows:
 - A. Depress forward end of control pedal. Wheels must rotate in forward direction. Remove pressure from pedal allowing it to return to neutral automatically. Wheels must stop rotation within seven seconds.
 - B. Depress reverse end of control pedal. Wheels must rotate in rearward direction. Remove pressure from pedal allowing it to return to neutral automatically. Wheels must stop within seven seconds.

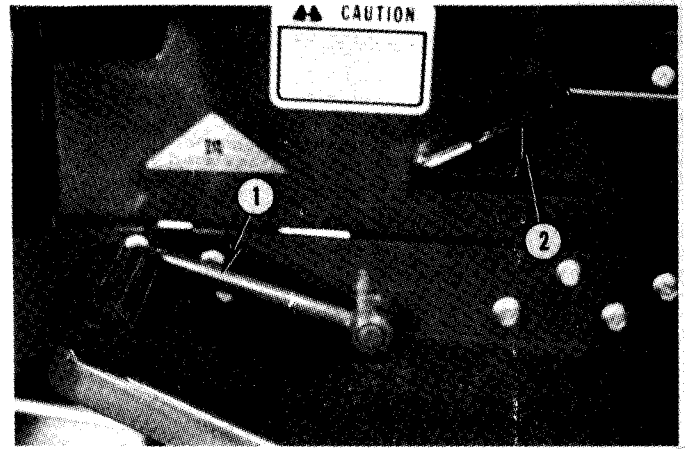

FIG. 3.15--1600 CLUTCH/BRAKE PEDAL ENGAGED
1. Pedal down. 2. Brake Lever Up.

11. Readjust nut on brake rod as follows:
 - A. Place speed selector lever in first speed notch of speed selector detent. (Brake rod adjusting lock nut should be making no contact with brake engaging sleeve in this position.)
 - B. Adjust the nut on the brake rod so that the engaging sleeve will make contact with the brake rod nut when the speed selector lever is 1/4 inch below the first speed notch.
12. Adjust forward/reverse linkage to obtain operator's desired pedal position.

BRAKE ADJUSTMENT (1600 SERIES)

1. Depress clutch-brake pedal, No. 1, Fig. 3.15, and engage parking brake lever, No. 2.
2. If lever will not engage, raise Tractor seat, remove tool box.
3. With clutch-brake pedal, No. 1, Fig. 3.16, in up position, increase clearance between bolt head, No. 5, Fig. 3.17, and brake arm, No. 4. Repeat Step 1 and readjust if necessary. Tighten jam nut, No. 3.

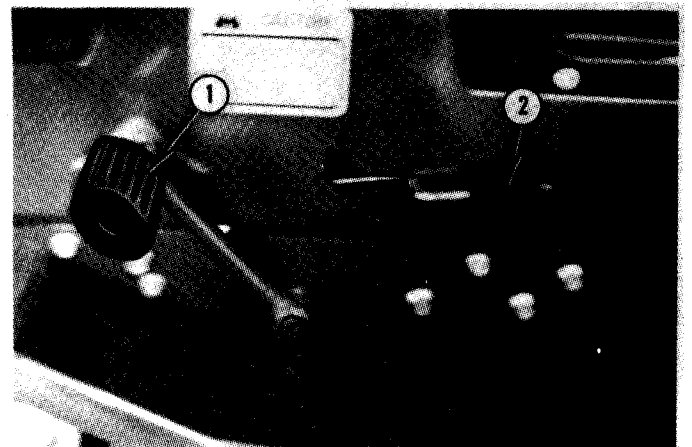

FIG. 3.16--1600 CLUTCH/BRAKE PEDAL RELEASED
1. Pedal up 2. Brake Lever down

BRAKE SERVICE - 1600 SERIES

Access to brake components on 1600 series tractors is gained by tilting the operator's seat forward and removing the tool tray. However, when brake band or drum replacement is required, it may be easier to jack the back of the tractor up and to remove the left rear wheel. If the brake does not function properly after readjusting as described on page 3.5, the band is probably worn excessively. Replace as follows:

1. Release parking brake to relieve tension on the brake band.
2. Remove the retaining ring securing the actuator rod to the brake lever and detach the rod.
3. Pull the cotter pin from the clevis pin holding the forward loop of the brake band to the brake lever and pull the pin.

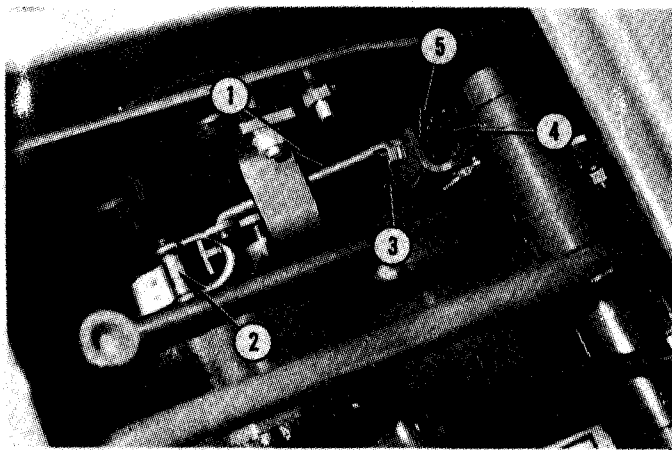

FIG. 3.17--1600 BRAKE ADJUSTMENT POINTS

1. Brake Actuator Rod. 2. Brake Band. 3. Jam Nut.
4. Brake Arm. 5. Bolt Head.

4. Remove the retainers and pull the pin holding the lever link and rear loop of the band to the lever. The band can now be removed and replaced. Before replacing, carefully inspect the surface of the brake drum. If excessively worn replace as described in step 5.

5. The brake drum is keyed to the transaxle and is held in position by a retaining ring. Remove the ring and use a puller to separate the drum from the transaxle. Reverse the foregoing to install replacement drum and/or brake band. Readjust brake after replacing.

SECTION 4 — TRANSMISSION, REAR AXLES & WHEELS

The first segment of this section covers the overhaul and repair of the transaxle and gearbox drive used on the 1600 series tractors. The hydrostatic transmission used on the 1650 and 1855 series is covered in the second segment.

A lifting device such as block and chain will be required to raise the tractor frame off the transmission — rear wheel assembly after these units are separated.

1600 SERIES TRANSAXLE AND GEARBOX

The transmission and rear axle assembly (transaxle) is driven by a "V" belt through a gear box. This part of the manual is divided into two parts, transaxle and gearbox. The transaxle has 4 speeds forward and 1 speed reverse.

TRANSAXLE REMOVAL

1. Disconnect wires and remove rear fender and seat assembly.
2. Remove drive belt from transaxle pulley and disconnect brake linkage at brake. Fig. 4.1.
3. Attach a suitable lifting device to tractor frame.
4. Remove transaxle retaining bolts. Fig. 4.1.
5. Raise tractor and remove transaxle assembly from tractor. Fig. 4.2.

TRANSAXLE INSTALLATION

1. Position transaxle under tractor as shown in Fig. 4.2 and lower tractor into place.
2. Install retaining bolts and tighten securely. Fig. 4.1.
3. Install belt and reconnect brake linkage.
4. Install rear fender and seat assembly and reconnect wires.

TRANSAXLE DISASSEMBLY AND REASSEMBLY

1. Shift transmission to neutral and remove shift lever. Fig. 4.3.
2. Remove both axle housings.
3. Block up transmission so that no pressure is in brake shaft with case side facing up. Fig. 4.4.
4. Cap dowel pins out of case into cover and remove bolts.
5. Lift case 1-1/2 to 2 inches above cover, tilt so case will clear shift rods, rotate case and remove from cover and gears. Fig. 4.4.

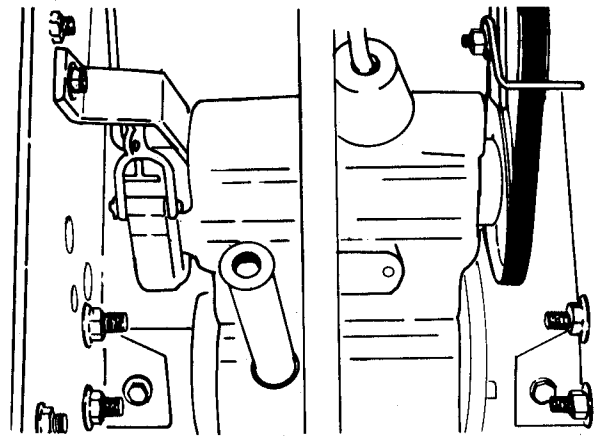

FIG. 4.1-TRANSAXLE RETAINING BOLTS

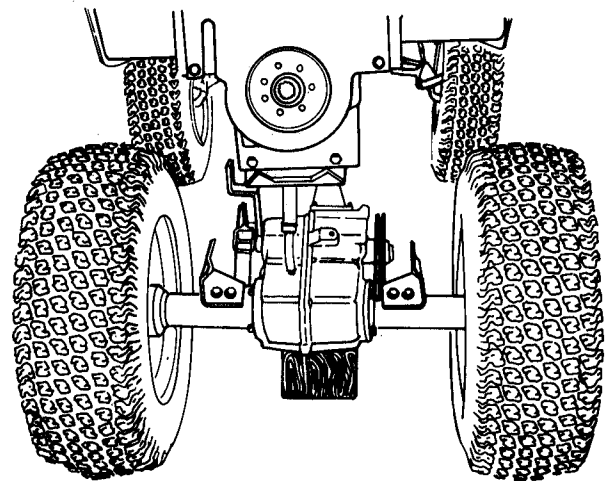

FIG. 4.2-LIFT TRACTOR OFF TRANSAXLE

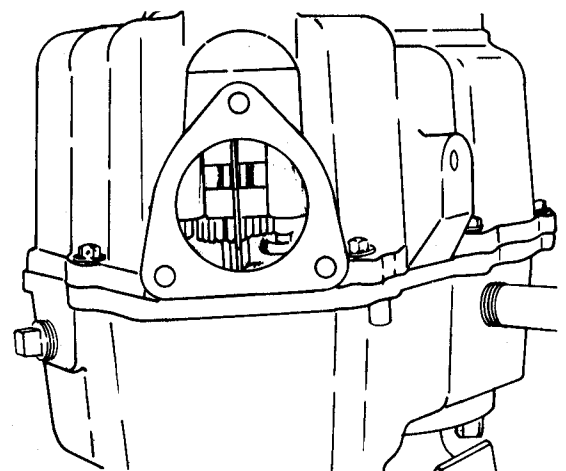

FIG. 4.3-TRANSAXLE SHIFT REMOVED

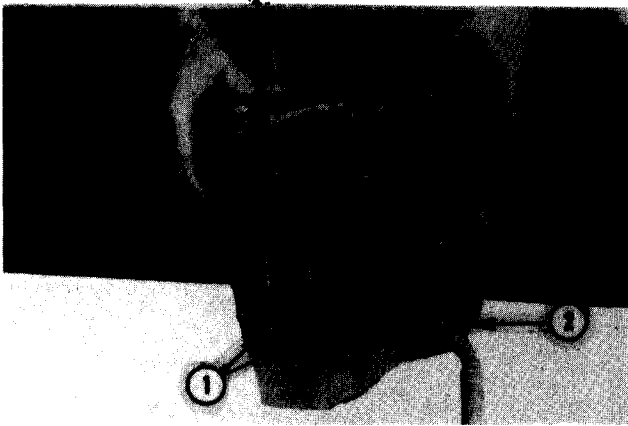

FIG. 4.4-PULLING TRANSAXLE

- 1. Shifter Rods.
- 2. Transaxle Case.
- 3. Transaxle Cover.

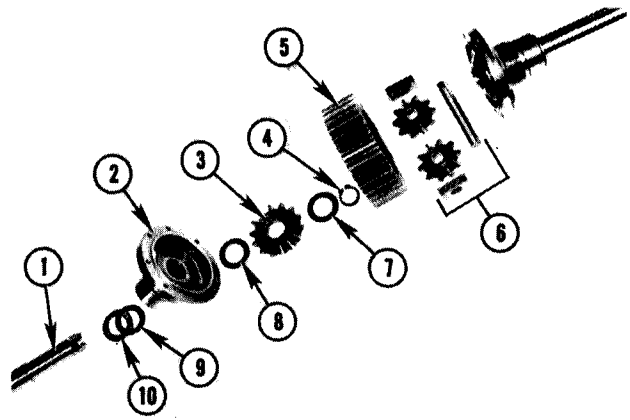

FIG. 4.7-DIFFERENTIAL PARTS SEQUENCE

- 1. Axle. 2. Carrier. 3. Side Gear. 4. Ret. Ring.
- 5. Ring Gear. 6. Pinions & Shaft. 7. Washer
- 8. Washer. 9. Washer. 10. Bearing.

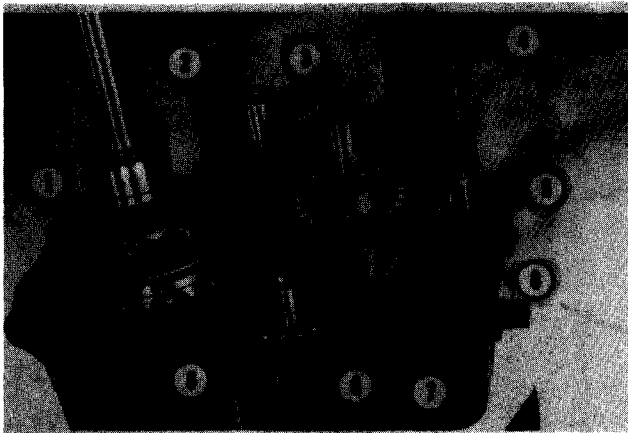

FIG. 4.5-TRANSAXLE GEARS & SHAFTS

- 1. Differential. 2. Output Shaft. 3. Brake Shaft.
- 4. Shift Rods. 5. Shifter Shaft. 6. Reverse Idler.
- 7. 2-Cluster Gear. 8. 3-Cluster Gear. 9. Low Gear Shaft.

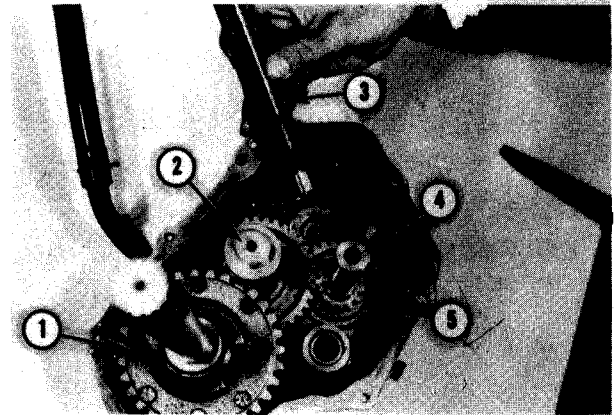

FIG. 4.8-SHAFT DETAIL

- 1. Differential Assembly.
- 2. Output Shaft. 3. Shifter Shaft.
- 4. Brake Shaft. 5. 2-Cluster Gear.

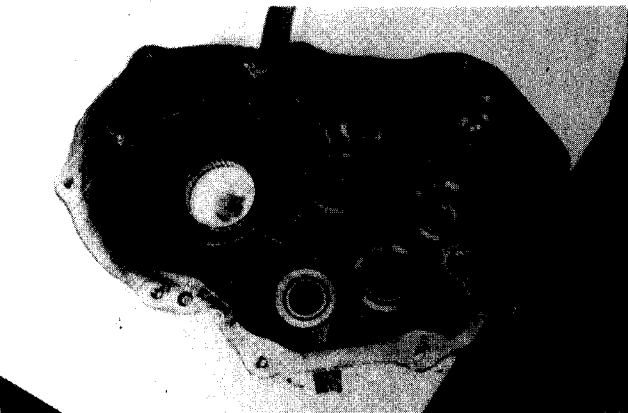

FIG. 4.6-GEAR CASE BEARINGS

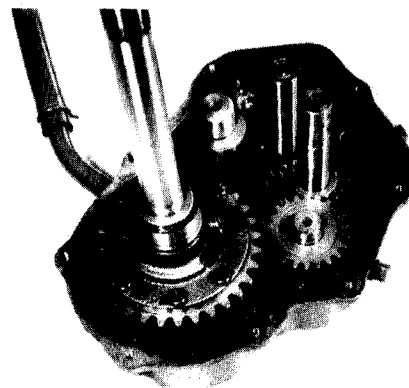

FIG. 4.9-LOW GEAR AND SHAFT

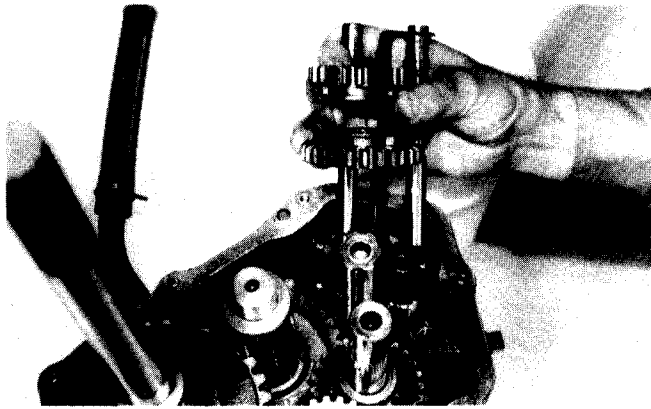

FIG. 4.10-SHIFT RODS AND GEARS

6. Refer to Fig. 4.5 and remove the following:

- a. Thrust washer and 3 gear cluster from brake shaft.
- b. Reverse idler gear and shaft.
- c. Hold shifter assembly together and lift out.
- d. Low gear and shaft.
- e. 2 cluster gear from brake shaft.
- f. differential assembly.
- g. Output Shaft.
- h. brake shaft.
- i. Input shaft and bearing.

7. Inspect all parts for wear or damage, replace as required. Replace all seals and gaskets. If bearings require replacement, position bearing cage flush with machined surface of bearing bore and press against lettered side of bearing. Fig. 4.6.

If differential requires any servicing refer to Fig. 4.7 for identification and sequence of parts.

8. Install input shaft into case. Use a soft mallet to seat shaft completely in cover.

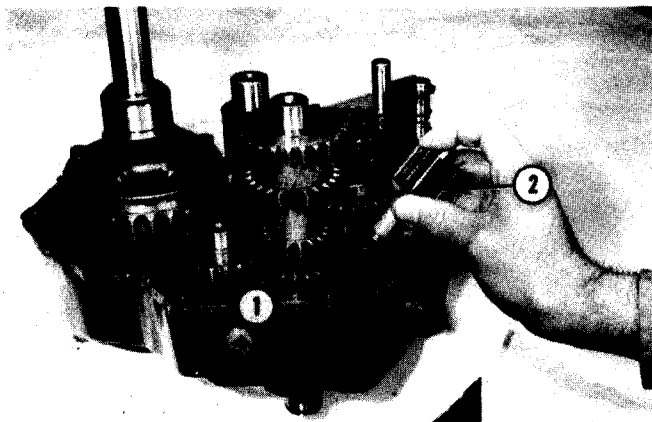

FIG. 4.11-REVERSE IDLER SHAFT & GEAR
1. 3-Cluster Gear. 2. Reverse Idler Gear & Shaft.



FIG. 4.12-AXLE HOUSING INSTALLATION

9. Refer to Fig. 4.8 and install the following:

- a. Brake shaft and 2 cluster gear.
- b. Output shaft and gear.
- c. Differential assembly with bolt heads away from output gear.
- d. Shifter shaft.

10. Install low gear and shaft. Fig. 4.9.

11. Hold shifter assembly together and install over shaft and into cover, Fig. 4.10.

12. Install 3 gear cluster and reverse idler shaft and gear, Fig. 4.11.

13. Work case around gears by tilting and rotating and install in place, Fig. 4.4 and secure with retaining bolts.

NOTE: If case and cover does not go completely together, rotate input shaft to cause gears to mesh. Case should drop to about 1/4 inch from cover.

14. Install axle housing and secure with retaining bolts. Fig. 4.12.

15. Install shim washes and hub, Fig. 4.13. Add or remove shims to eliminate axle end-play.

16. Fill transaxle to level plug with SAE-EP 90 transmission oil.

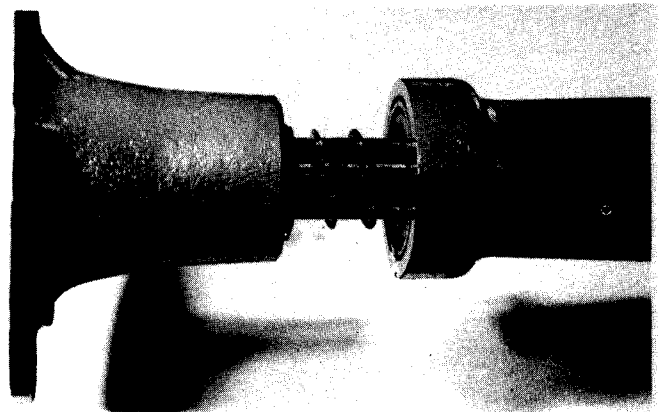

FIG. 4.13-SHIMS ELIMINATE END PLAY

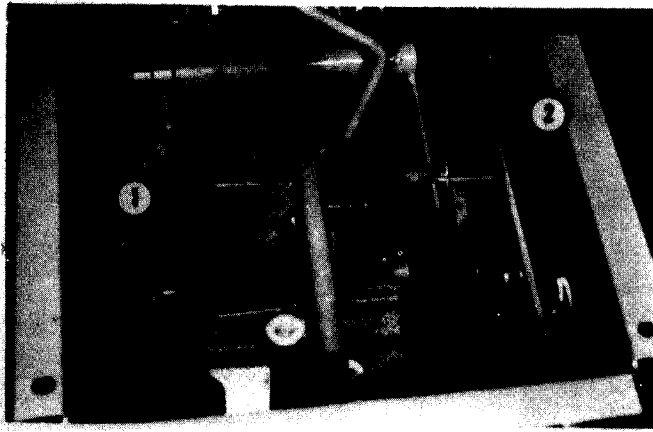

FIG. 4.14-GEARBOX LOCATION
1. Gear Box. 2. Drive Belt.

1600 GEARBOX

1. Remove cover over drive shaft and remove belt from gear box pulley.
2. Remove bolts securing gear box to tractor frame.
3. Remove gear box from beneath tractor Fig. 24.
4. To reinstall gear box proceed as follows:
 - a. Position gear box in place as shown in Fig. 4.14.
 - b. Install bolts and tighten securely. Fig. 4.15.

Gearbox Disassembly

1. Remove gearbox from tractor and remove pulley.
2. Punch two small holes in output shaft seal with a sharp punch as close to outer edge as possible. Do not drill these holes or bearing below seal could be damaged.
3. Install two metal screws into these holes. Fig. 4.16.
4. Pry seal out of housing with a suitable bar or screwdriver.
5. Remove cover and seal from over input shaft. Fig. 4.17.

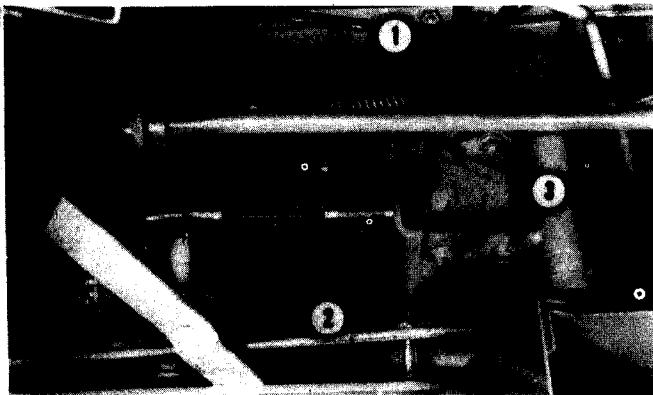

FIG. 4.15-GEARBOX RETAINING BOLT
1. Drive Belt. 2. Coupling. 3. Retaining Bolts.

6. Pull input shaft and bearing out of housing and gear as shown in Fig. 4.18.
7. Remove snap ring from output shaft as shown in Fig. 4.19.
8. Remove output gear, bearing and shaft from housing.
9. Remove snap ring and remove gear and bearing from output shaft. Fig. 4.20.
10. If the other bearing for the input shaft requires removal, heat housing and remove bearing.

Gearbox Reassembly

See Fig. 4.21

1. Heat housing and install input shaft bearing, if removed. Fig. 4.22.
2. Assemble bearing and gear on output shaft and secure with retaining ring, Fig. 4.20.

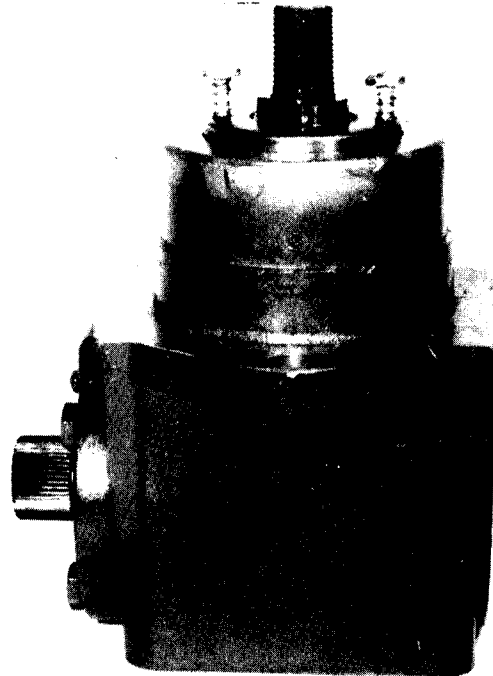

FIG. 4.16-GEARBOX ASSEMBLY

3. Install output shaft into housing as shown in Fig. 4.23.
4. Hold output shaft in place and install snap ring, as shown in Fig. 4.9.
5. Carefully slide seal over output shaft and install into housing. Drive seal into housing until it is flush with housing. Fig. 4.24.
6. Install input shaft with bearing into housing and gear, as shown in Fig. 4.18.
7. Install new seal into input shaft cover .040" to .050" below flush.
8. Install cover and seal with gasket over input shaft and secure with retaining bolts.
9. Fill case with approximately 4 oz. of moly EP lithium grease.

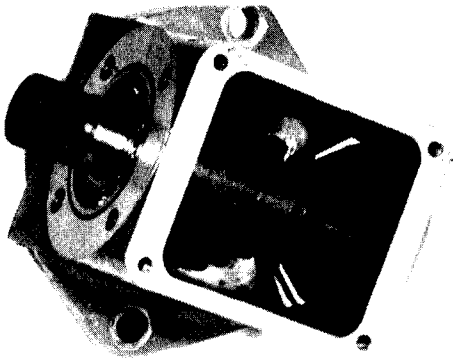

FIG. 4.17-COVER & SEAL REMOVED

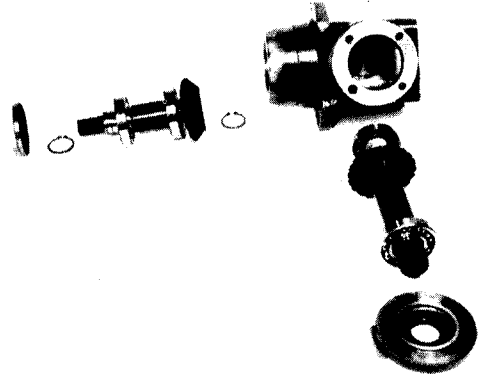

FIG. 4.21-GEARBOX PARTS SEQUENCE

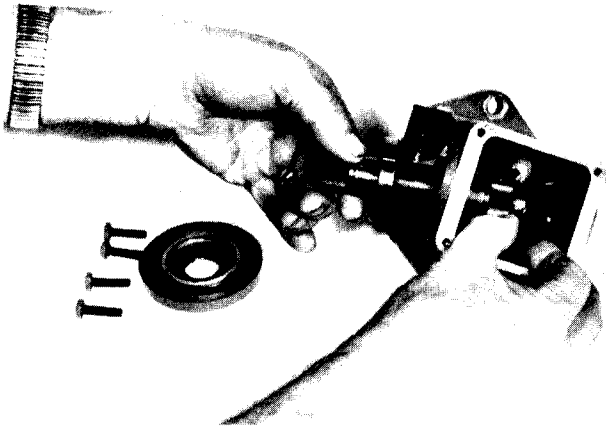

FIG. 4.18-PULLING INPUT SHAFT

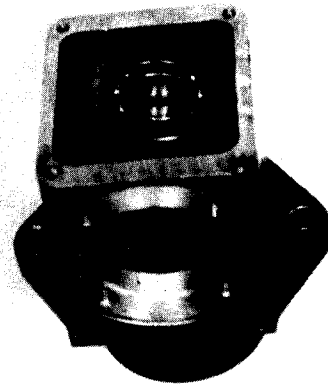

FIG. 4.22-INPUT SHAFT BEARING

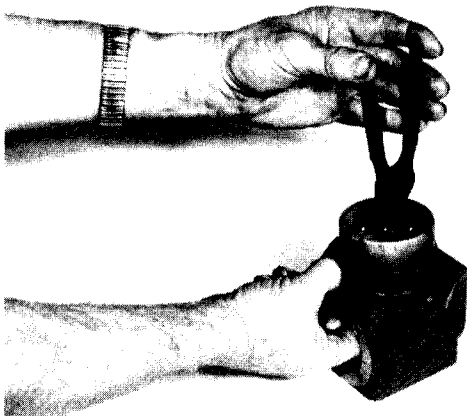

FIG. 4.19-OUTPUT SHAFT SNAP RING



FIG. 4.23-OUTPUT SHAFT INSTALLATION



FIG. 4.20-GEAR RETAINING SNAP RING

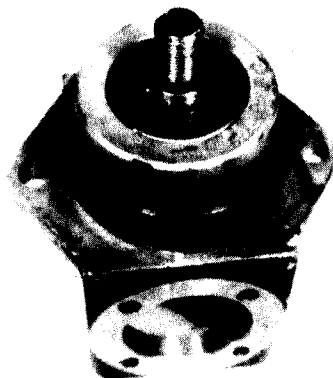

FIG. 4.24-OUTPUT SHAFT SEAL INSTALLED

HYDROSTATIC TRANSMISSION (1650 & 1855 SERIES)

This hydrostatic transmission is composed of four major components: A charge pump, a variable displacement radial ball-piston pump, a fixed displacement radial ball-piston motor and a system of valves located between the pump and motor.

The charge pump draws oil from the rear axle housing and performs three functions:

1. Maintains pressure (30-50 psi) on the low pressure side of the circuit to charge the variable displacement pump.
2. Supplies oil lost due to internal leakage in the loop circuit.
3. Provides a source of auxiliary hydraulic power to operate double-acting cylinders.

The variable displacement ball-piston pump consists of five "free" ball-pistons, each contained in a single piece five bore rotor unit. Like the charge pump, it is con-

trols the amount of oil being pumped by infinite movement from neutral to a maximum off center position.

The fixed displacement ball-piston motor is similar in appearance to the pump. Its cam ring is permanently fixed in an off center position. The motor turns only when the pump is pumping oil and since the pump can pump oil in either direction, it can make the motor rotate in either direction. Also, since the pump output volume of oil can be controlled by the pump cam ring it can make the motor turn fast or slow and any infinite speed in between.

The motor is connected to the rear axle input shaft and thus the Tractor moves forward, backward, slowly or swiftly.

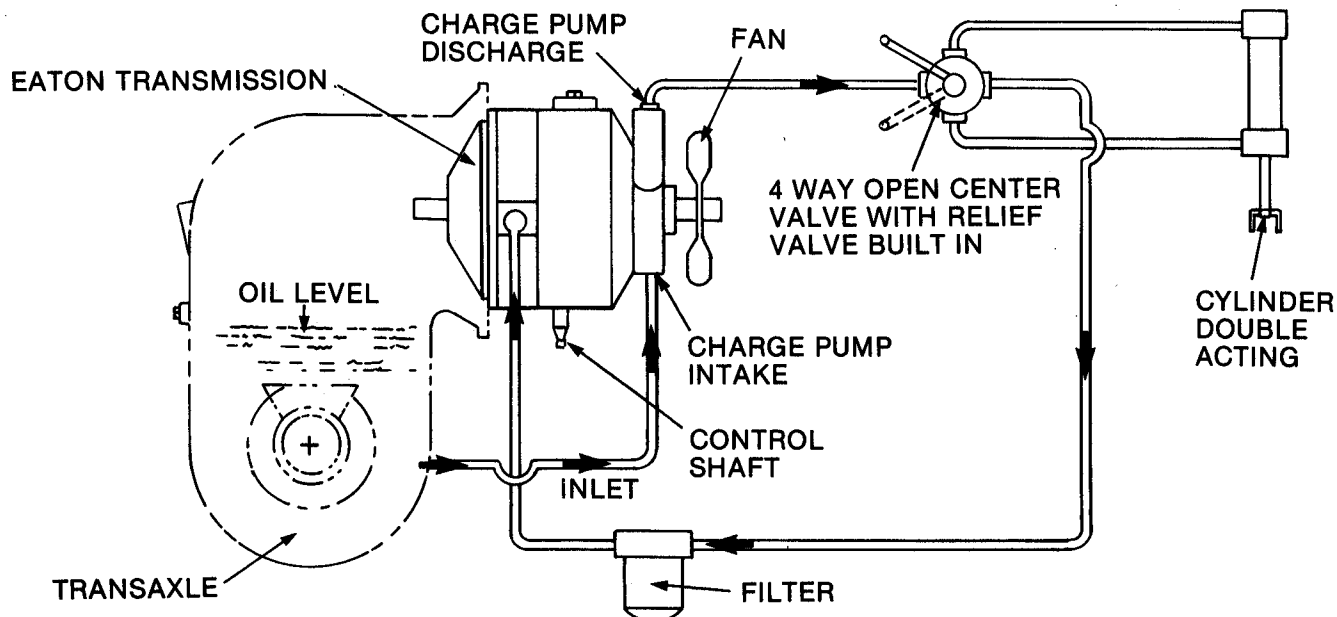

FIG. 4.25-SCHEMATIC OF HYDROSTATIC DRIVE SYSTEM

stant running unless disconnected from the engine. The ball-pistons travel within a radius controlled by a moveable cam ring. The cam ring is controlled by the operator.

When the cam ring is centered around the rotor unit the ball-pistons do not move in or out within the bores thus, no pumping action takes place and the transmission is considered to be in neutral. Moving the cam ring off center around the rotor unit will cause the ball-pistons to move in and out within their bores and oil will be pumped.

Since the cam ring can be moved off center in either direction from neutral, the pump can pump oil in either direction without a change in rotation. The cam ring also con-

trols the amount of oil being pumped by infinite movement from neutral to a maximum off center position. The valve system located between the pump and motor consists of check valves, acceleration valves, a charge pump relief valve and dampening pistons. Fig. 4.25 shows the complete hydraulic circuit on the Tractor. On 3-point hitch equipped tractors there would be an extra valve, cylinder and two connecting lines.

IMPORTANT NOTE

This transmission does not contain an implement relief valve. Implement relief valve is located in the auxiliary hydraulic control valve.

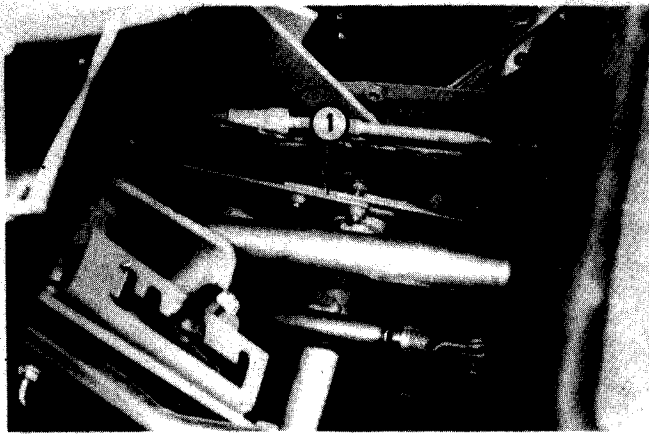

FIG. 4.26-FORWARD/REVERSE LINKAGE

1. Adjustable links.

LINKAGE CHECKS

Before attempting to adjust transmission linkage, perform following checks:

1. Start tractor
2. Place rear axle shift lever in low speed range
3. Release neutral return and brake pedal.
4. Place right foot on heel and toe pedal
5. Tilt right foot to rotate toe end of pedal downward. Tractor should travel forward.
6. Remove foot from pedal, tractor should stop and remain stopped.
7. Place right foot on pedal and tilt foot to rotate heel end of pedal downward. Tractor should travel rearward.
8. Remove foot from pedal, tractor should stop and remain stopped.
9. Drive tractor forward at maximum speed, then flip rear axle shift lever to neutral position and depress neutral return brake pedal. Rear wheels should slide.

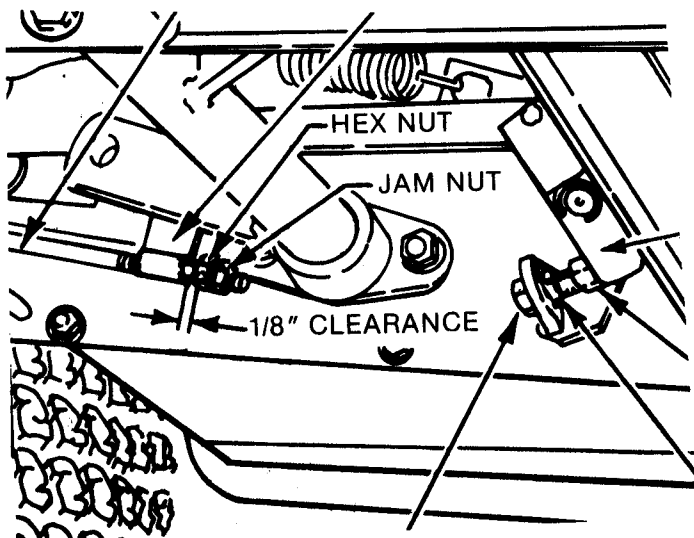

FIG. 4.27-LINKAGE ADJUSTMENT POINTS

LINKAGE ADJUSTMENTS

1. Block tractor up so that rear wheels are free to rotate.
2. Loosen nut on brake rod to end of rod Fig. 4.26.
3. Place speed control/parking brake lever in park position.
4. Depress clutch/brake pedal against step plate.
Adjust screw no. 3 Fig. 4.27 to obtain zero clearance between end of screw and selector link, then tighten lock nut.
5. Raise tractor seat and clamp safety switch to hold circuit closed so engine will start.
6. Remove cotter pin and retainer from adjuster. Fig. 87.
7. Start engine, shift speed control lever out of park and axle shift lever in gear.

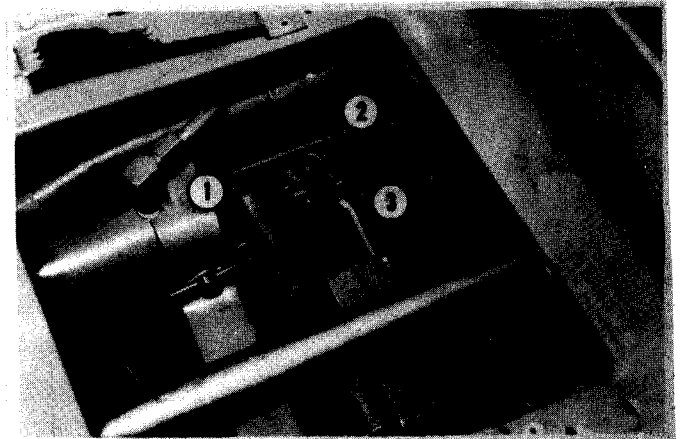

FIG. 4.28-TRANSMISSION SHIFT ADJUSTMENTS

1. Shift Adjuster. 2. Retainer. 3. Cotter Pin.

8. Turn adjuster no. 1, Fig. 4.28 in one direction until wheels rotate then turn adjuster in opposite direction until wheels rotate in other direction. Place adjuster in center of these two turns. (This is a neutral position and wheels should not rotate)

9. Make final check of adjustments as follows:

a. Depress forward end of forward-reverse pedal. Wheels must rotate in forward direction. Remove pressure from pedal allowing it to return to neutral automatically. Wheels must stop within seven seconds.

b. Depress reverse end of forward-reverse pedal. Wheels must rotate in rearward direction. Remove pressure from pedal allowing it to return to neutral automatically. Wheels must stop within seven seconds.

10. Readjust nut on brake rod as outlined under heading "Brake adjustment"

11. Adjust Forward/Reverse linkage Fig. 4.26 to obtain pedal position to suit operator.

BRAKE ADJUSTMENT

1. Place speed control/parking brake lever in park position.
2. Loosen nut no. 2 Fig. 4.27 at end of brake rod.
3. Tighten nut no. 1 Fig. 4.29 to eliminate clearance between brake pucks and disc then back off one-half turn. This provides approximately .020" running clearance for brake disc.
4. With speed control lever in park position, pull brake rod forward with 10-20 lbs. tension and tighten brake rod nut against tubular guide. Continue to tighten nut two additional turns.

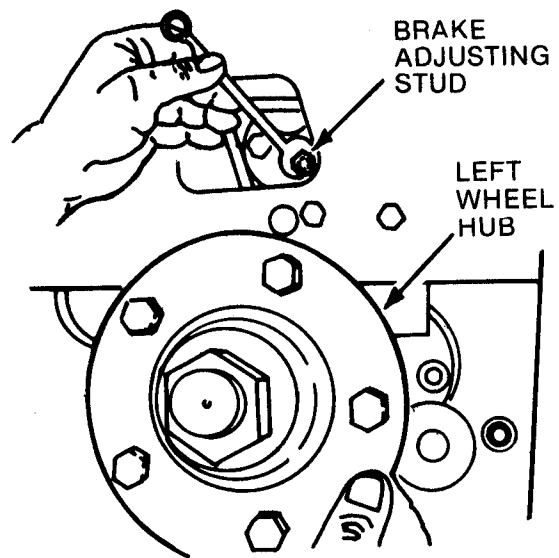

FIG. 4.29-BRAKE PUCKER ADJUSTMENT

TRANSMISSION TROUBLE SHOOTING GUIDE

Problem	Possible Cause
Tractor will travel one direction but not the other	<ul style="list-style-type: none"> Check valve stuck or out of position Control shaft inboard bearing web broken. Control shaft spacer bent or broken Control shaft dowel-pin out of position One acceleration valve stuck open Control linkage out of adjustment
Tractor will not move either direction.	<ul style="list-style-type: none"> Axle in neutral Control linkage broken or disconnected Control shaft dowel pin broken Output shaft dowel pin broken Oil supply lost Oil filter blocked Restriction, such as plastic caps or plugs in oil circuit
Erratic tractor motion travel demand	<ul style="list-style-type: none"> Erratic check valve Malfunctioning acceleration valves
Output torque trails off after short operating period	<ul style="list-style-type: none"> Loss of oil Filter restricted Restriction, such as plastic caps or plugs in oil circuit Oil temperature in excess of 180 degrees F. caused by overloading.

TRANSMISSION TROUBLE SHOOTING GUIDE (continued)

Problem	Possible Cause
Output Torque Trails Off, Etc. (Continued)	<p>Cooling fan inoperative or ineffective because of foreign material such as grass blocking air flow thru cooling fins.</p> <p>Water in oil</p> <p>Internal leakage between ball-pistons and bores, leakage between rotor and pintle journal</p>
Output torque "not as good as new"	<p>Loss of engine power</p> <p>Internal leakage due to wear</p> <p>Control linkage needs adjustment</p>
Engine lugged to a stall — input shaft will not turn	<p>Pump seized to pintle</p> <p>Ball-piston seized in bore</p>
Loss of charge pump pressure	<p>Loss of oil</p> <p>Scored charge pump cam, carrier or plate</p> <p>Loose charge pump mounting bolts</p> <p>Restriction, such as plastic caps or plugs in charge pump inlet circuit</p> <p>Implement relief valve in auxiliary hydraulic control valve defective or incorrectly set</p>
Oil leaks	<p>Porous or cracked castings</p> <p>Oil seals defective</p> <p>Oil line connections loose or defective</p> <p>Back pressure due to non-ventilated rear axle</p>
<p>Noise</p> <p>NOTE: Complaint in most cases is personal opinion which cannot be resolved as the fault of the transmission. Noise that forecasts failure should be given serious attention.</p>	<p>Worn control linkage</p> <p>Stuck check or acceleration valves</p> <p>Motor bushing rotated</p> <p>Worn motor bushing</p> <p>Aeration — Cavitation</p> <ol style="list-style-type: none"> a. Loose fittings b. Improper filter installation c. Restriction in charge pump inlet line <p>Excessive load</p> <ol style="list-style-type: none"> a. Incorrect brake release b. Defective final drive train in rear axle <p>Low on oil or water in oil.</p>

1650, 1855 TRANSMISSION REMOVAL/INSTALLATION

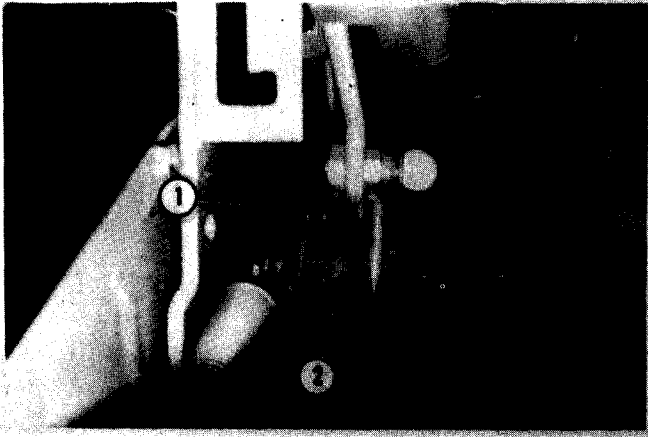

FIG. 4.30-CLUTCH/BRAKE ROD DISCONNECTED

1. Control Arm. 2. Clutch Pedal Arm.

REMOVAL

Rear axle and transmission should be removed from tractor as an assembly. To remove proceed as follows:

1. Disconnect rear light wires and wires from seat safety switch.

2. Remove bolt at rear of each seat slide and bolts from rear of step plates.

3. Remove knobs from controls and lift seat and rear fender assembly off tractor.

4. Remove dress panel over drive shaft.

5. Disconnect clutch/brake control rod at front. Fig. 4.30.

6. Disconnect Forward/Reverse pedal linkage at rear, Fig. 4.31.

7. Remove three point hitch if equipped, Fig. 4.32, as follows:

a. Disconnect lower links at axle housings.

b. Disconnect check chains at front end of chains.

c. Unhook hydraulic cylinder from rock shaft.

d. Remove bolts securing rock shaft brackets to tractor and remove complete three point hitch.

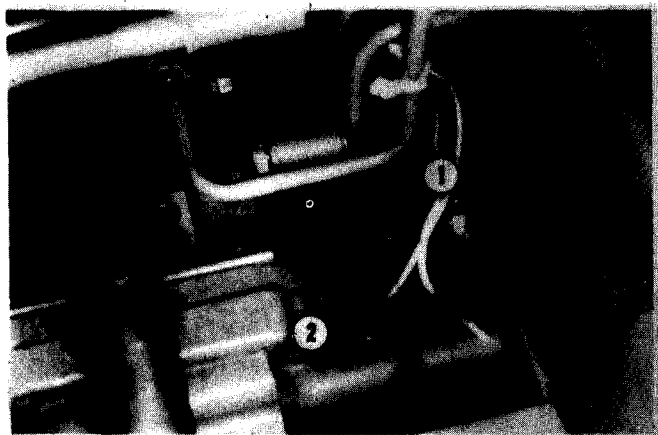

FIG. 4.31-FORWARD/REVERSE LINKAGE

1. Linkage. 2. Shift Arm.

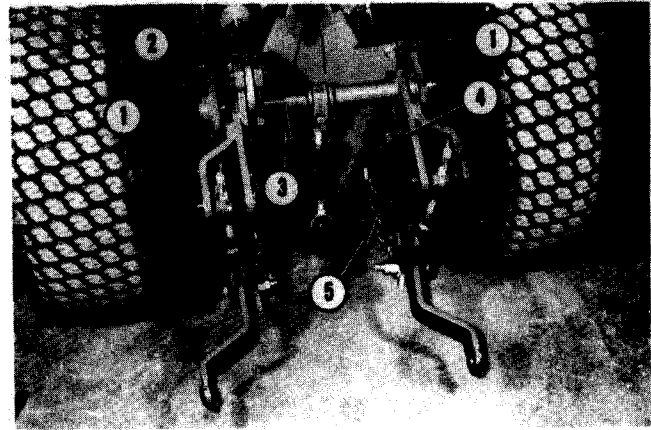

FIG. 4.32-THREE-POINT HITCH PARTS

1. Bracket Bolts (4) 2. Hydraulic Lift Cylinder.
3. Rock Shaft. 4. Lower Link Pin. 5. Check Chain.

8. Remove four bolts securing plate or PTO belt cover, if equipped with PTO to tractor frame, Fig. 4.33.

9. If tractor is equipped with PTO refer to Fig. 4.34 and proceed as follows:

a. Remove bolts securing rear plate and bearing assembly in place.

b. Remove PTO assembly from tractor.

10. Disconnect brake return spring from cotter key at left rear of tractor frame and remove PTO plate assembly, if equipped. Fig. 4.35.

11. Disconnect wires from clutch/brake safety switch.

12. Block front axle pivot to prevent tractor from tipping and attach a suitable lifting device to rear frame.

13. Remove bolts securing mounting plate at axle housing and frame.

14. Remove bolts and spacers at upper side of transaxle.

NOTE: Spacers at upper side of transaxle are different lengths. Right spacer is longer and is identified by a groove around it.

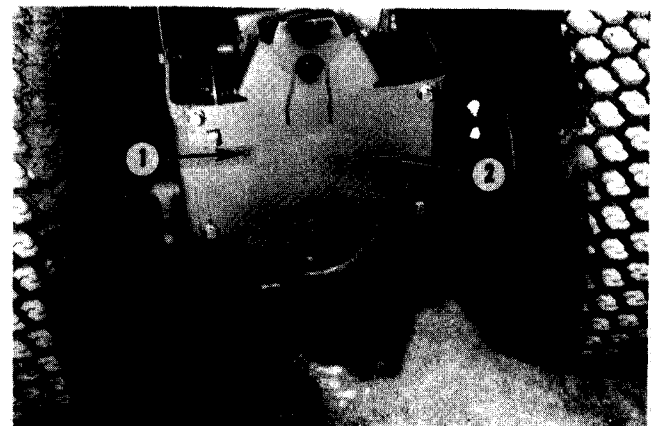

FIG. 4.33-REAR PTO COVER

1. Belt Guide Pin (Early Models). 2. Cover.

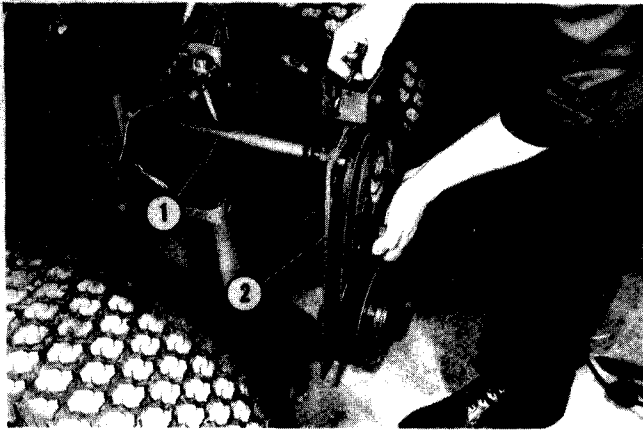

FIG. 4.34-PULLING REAR PTO

1. Rear PTO Shaft. 2. Rear Plate & Bearing.

15. Place foot on drawbar and maneuver assembly out while raising tractor frame Fig. 4.36.

16. Continue rolling unit out and place block under transmission. Fig. 4.37.

INSTALLATION

1. Raise tractor frame and maneuver transmission and axle assembly into place. Fig. 4.36.

2. Bolt axle housings to frame using adapter plates.

3. Install bolts and spacers at upper side of transaxle — Longest spacer on right side identified by a groove around it.

4. Connect wires to clutch/brake safety switch.

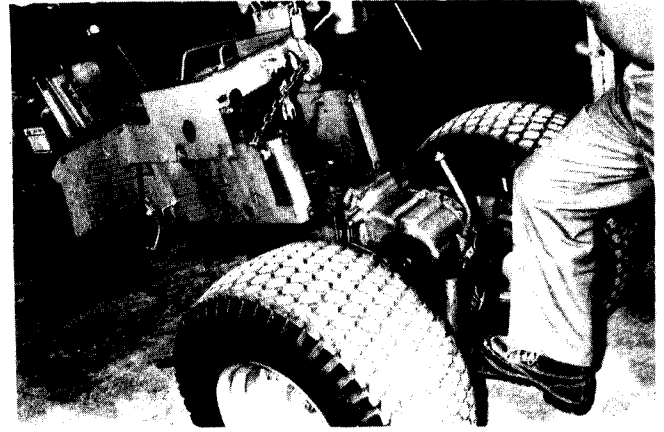

FIG. 4.36-LOWERING TRACTOR ON TRANSAXLE

5. Connect brake return spring. Fig. 4.35.

6. If equipped install PTO and align coupler between engine and shaft. Fig. 4.34.

7. Install rear plate or belt cover to rear of frame. If belt cover be sure belt guide in cover is on outside of belts. Fig. 4.33.

8. Install three point hitch, if equipped.

9. Connect forward/reverse pedal linkage at rear. Fig. 4.31.

10. Connect clutch/brake control rod at front. Fig. 4.30.

11. Install dress panel over drive shaft.

12. Install rear fender assembly, control knobs, connect wires to seat safety switch and rear lights.

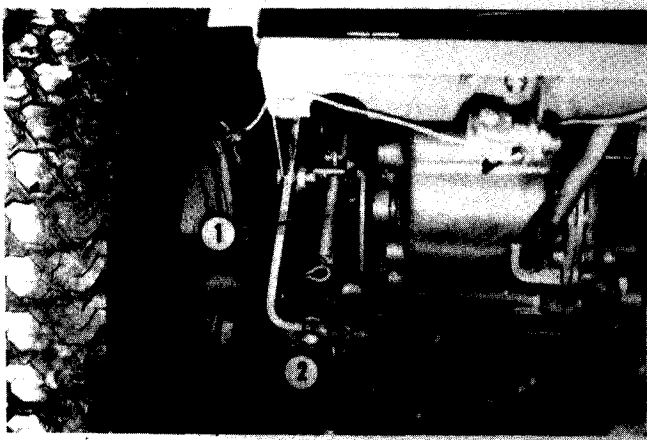

FIG. 4.35-BRAKE RETURN SPRING

1. Brake Return Spring. 2. PTO Mounting Plate.

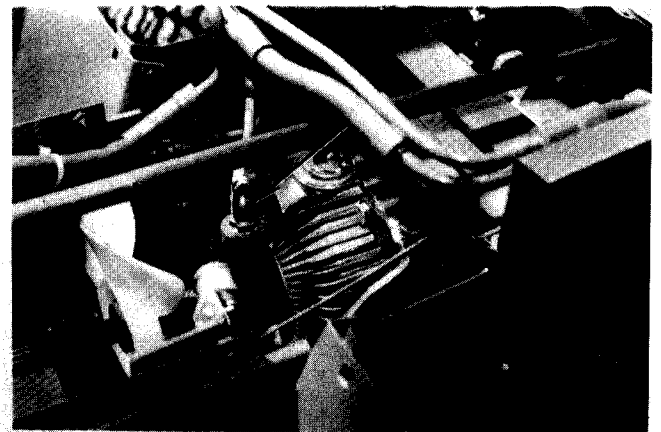

FIG. 4.37-TRANSMISSION INSTALLED

TRANSMISSION OVERAL & REPAIR

IMPORTANT!

Do not start disassembling this transmission without following these instructions. The ballpistons are select fit in each bore and must not be mixed. These ball-pistons can fall out of the rotor if precautions are not taken during rotor removal. If that happens a new ball-piston and rotor assembly must be installed.

NOTE: Cap all open ports and thoroughly clean transmission externally before disassembly. A fast drying agent that is not harmful to lip seal rubber, gaskets or plastic is recommended.

Air pressure may be used for cleaning or drying provided high pressure is not directed at lip seals. Work area must be clean; fresh clean paper is suggested to cover work bench or table for layout of parts.

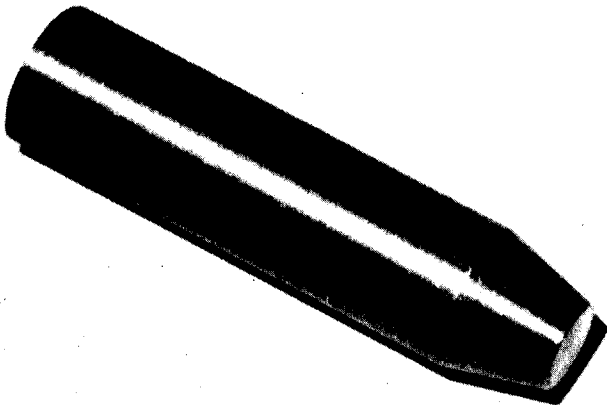

FIG. 4.38-SEAL SLEEVE TOOL

OIL SEAL REPLACEMENT

The transmission input shaft oil seal and the control shaft oil seal can be replaced without disassembly of the transmission, however transmission should be removed from the Tractor and cleaned externally before attempting seal replacement. Either seal may be removed by piercing it with a narrow sharp tool.

NOTE: Care must be exercised not to damage the shafts or seal counterbores during seal removal. Also, care must be taken when removing the control arm from the control shaft as internal damage can occur if arm is pried or driven severely. A suitable puller is recommended.

New seals should be installed using seal, sleeve tool, Fig. 4.38. The seal lip must be toward the inside and it is recommended that the outside diameter of the seal be coated with a thin coat of Loctite prior to installation.

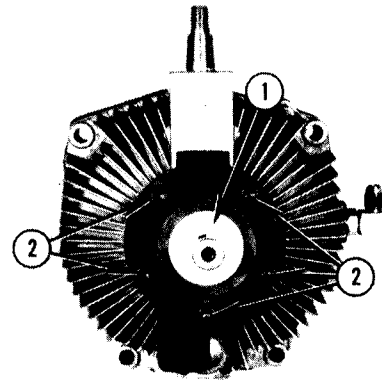

FIG. 4.39-EATON #1100-031 TRANSMISSION

1. Grass Shield. 2. Retaining Bolts (5).

DISASSEMBLY OF TRANSMISSION

NOTE: A block of wood 2"x6"x10" with a 3/4" hole in the center is recommended as a stand.

1. Position transmission in stand with input shaft up.
2. Remove grass shield, No. 1, Fig. 4.39, and then remove five bolts, No. 2, noting location of long bolt.
3. Lift off charge pump body being careful not to damage oil seal noting position of six rolls, No. 1 Fig. 4.40.
4. Before removing the roll carrier, carefully note its position on the pump shaft as it can be installed incorrectly. The leading surface of the roll carrier will form a straight line to the center of the pump shaft when it is

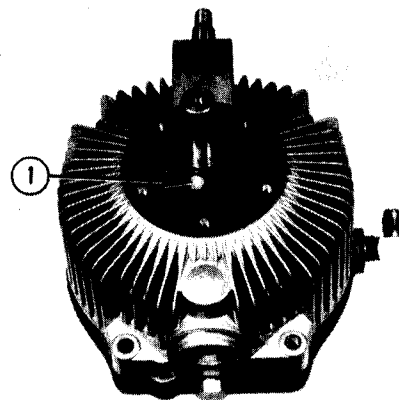

FIG. 4.40-CHARGE PUMP CARRIER & ROLLS (6)

1. Charge Pump Carrier Rolls (6).

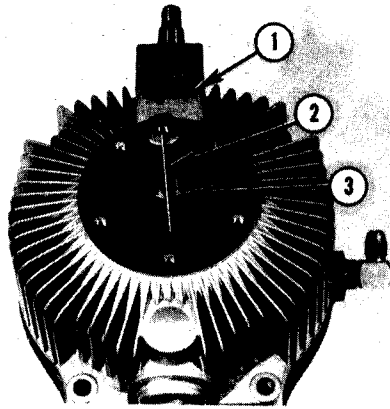

FIG. 4.41-PUMP ROTATION INDICATOR

1. Rotational Direction Arrow.
2. Reference line.

correctly installed, note rotation of pump, No. 1, Fig. 4.41, and straight line, No. 2. Remove snap ring, No. 3, to remove roll carrier.

5. When roll carrier, No. 1, Fig. 4.42, is lifted off note position of carrier drive pin, No. 2. Be extra careful in removing this pin. It is round and loose fitting and may be easily dropped.

6. Remove pump plate, No. 1, Fig. 4.43, noting "O" - ring, No. 2.

NOTE: If no further disassembly of the transmission is needed the charge pump may now be repaired as necessary and re-assembled.

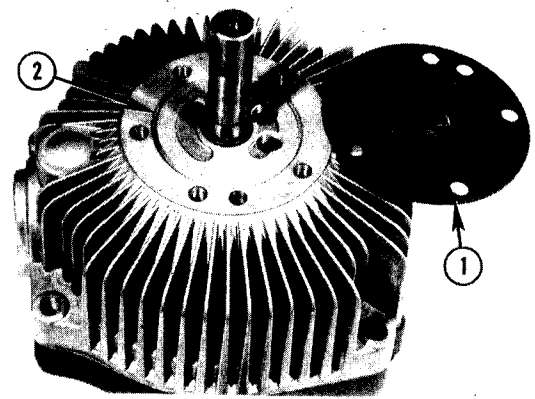

FIG. 4.43-PUMP PLATE & O-RING

1. Pump Plate Removed.
2. O-Ring.

7. Repair charge pump as necessary noting the following.

a. If pump plate is scored, it must be replaced along with rolls, roll carrier and pump body as a set.

b. It is recommended that new "o" - rings be installed on both sides of the pump plate during reassembly. One "o" - ring is located in groove, No. 2, Fig. 4.43 and the other is in groove, No. 2, Fig. 4.44.

c. Check for excessive wear between bushing, No. 1, Fig. 4.44, in charge pump and input shaft. Specified clearance is .0013" to .0033". Replace parts as necessary.

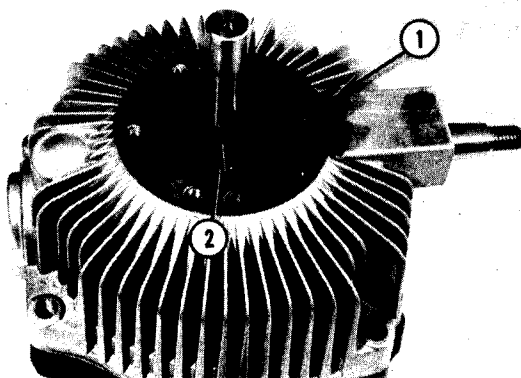

FIG. 4.42-CARRIER DRIVE PIN

1. Roll Carrier.
2. Carrier Drive Pin.

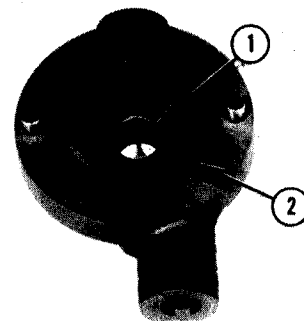

FIG. 4.44-CHARGE PUMP BUSHING & O-RING

1. Charge Pump Bushing.
2. O-Ring.

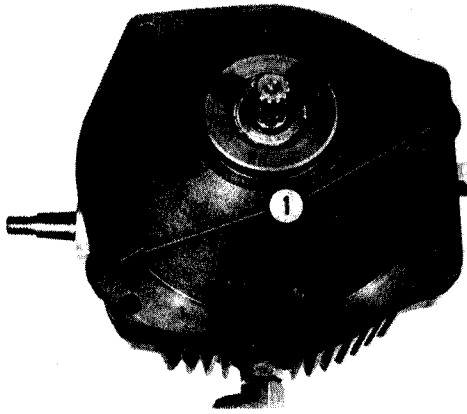

FIG. 4.45-OUTPUT SHAFT SIDE UP

1. Housing Retaining Screws

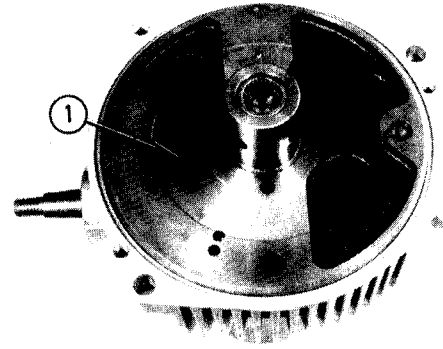

FIG. 4.48-PINTLE VALVE BODY

1. Pintle Assembly Body.

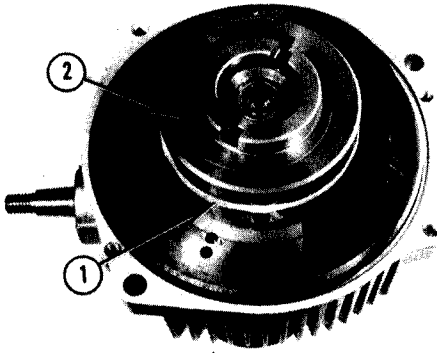

FIG. 4.46-MOTOR ROTOR BALL-PISTONS

1. Rubber Band. 2. Motor Rotor.

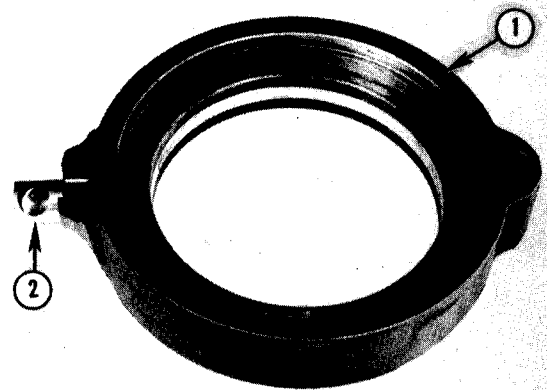

FIG. 4.49-CAM RING & PUMP RACE

1. Cam Ring & Race. 2. Ring Insert.

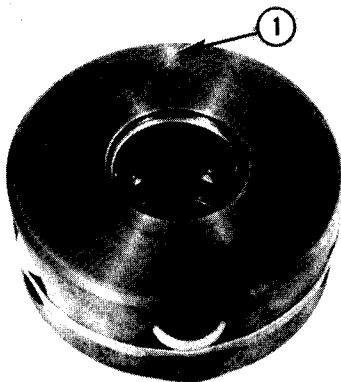

FIG. 4.47-LETTER STAMPING ON ROTOR

1. Location of Letter Stamping.

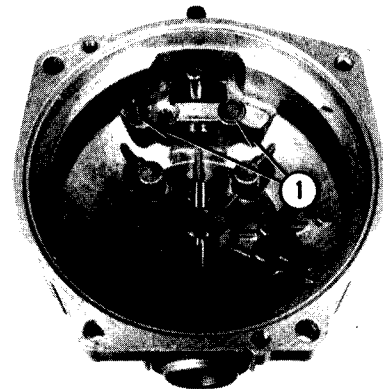

FIG. 4.50-CAM RING WEAR BUTTONS

1. Wear Button Location (2).

REASSEMBLY OF TRANSMISSION

NOTE: The input shaft cannot be replaced without complete disassembly of transmission. If further disassembly is necessary follow the next steps.

8. Invert transmission on wood block so that output shaft is up as shown in Fig. 4.45.

NOTE: Be sure transmission is level and stable on the wood block.

9. Remove two cap screws, No. 1, Fig. 4.45, and then re-install about two threads.

10. The cast iron assembly is now ready for initial separation from the aluminum body. If possible lift the cast iron assembly to the limit of the cap screw stops. If difficulty is encountered in separating the two components use a plastic hammer to tap the components to break the fluid seal.

When the seal is broken, remove cap screws and very gently lift off the cast iron assembly.

11. Being careful not to disturb the transmission place a strong rubber band, No. 1, Fig. 4.46, around the motor rotor to prevent the ball-pistons from falling out.

12. The motor rotor assembly may now be lifted out but extra care should be exercised in handling.

13. Select an egg carton and number two rows of five holes.

14. Locate a letter, No. 1, Fig. 4.47, stamped on the face of the rotor.

15. Working clockwise from the letter remove ball-pistons one at a time and place in egg carton.

16. The pintle assembly (valve body). No. 1, Fig. 4.48 may now be lifted from the aluminum body.

17. The pump rotor assembly is now ready to be lifted out exercising the caution and method to hold the ball-pistons in place as with the motor rotor.

18. Locate letter, stamped on the face of the pump rotor.

19. Working clockwise from the letter, remove the ball-pistons one at a time and place them in egg carton.

20. The cam ring and pump race assembly, No. 1, Fig. 4.49, may now be lifted out noting carefully the position of cam ring insert, No. 2. (The thin wall end of the insert must always be positioned outboard).

21. With the pump cam ring now removed the inside of the aluminum body is now exposed, Fig. 4.50. Note that there are two buttons. No. 1, loose fitting in holes in the aluminum body. The buttons serve to prevent the cam ring from contacting the aluminum cover.

Reassembly of this transmission is the reverse of disassembly. It is during this procedure that final examination of all parts should be made and replacements installed as necessary. Following is recommended procedure for reassembly.

1. Examine aluminum body for any evidence of cracks and if found replace body.

2. Inspect for excessive clearance between input shaft and aluminum body bushing. Specified clearance is .0013" to .0033". If clearance is excessive replace body as bushing is not replaceable.

3. Remove snap ring, No. 1, Fig. 4.51, from input shaft, No. 2, and slide shaft inward. Inspect input shaft assembly, Fig. 4.52, for excessive wear and replace if necessary.

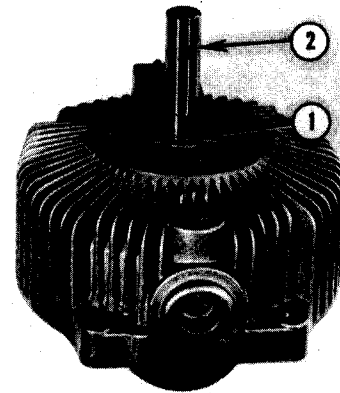

FIG. 4.51-INPUT SHAFT SNAP RING

1. Input Shaft Snap Ring Location.
2. Input Shaft.

4. Inspect cam ring dowel pin, No. 1, Fig. 4.53, in aluminum body. If loose, body must be replaced.

5. Inspect control shaft assembly, in cover, If shaft is excessively loose in the cover it is highly probable that a new cover will be required.

6. Examine pump ball-piston race in cam ring. If scored, cam ring and race assembly must be replaced.

7. Examine pump rotor bores and ball-pistons for any evidence of scoring, pitting, contamination, or excessive wear and replace if necessary.

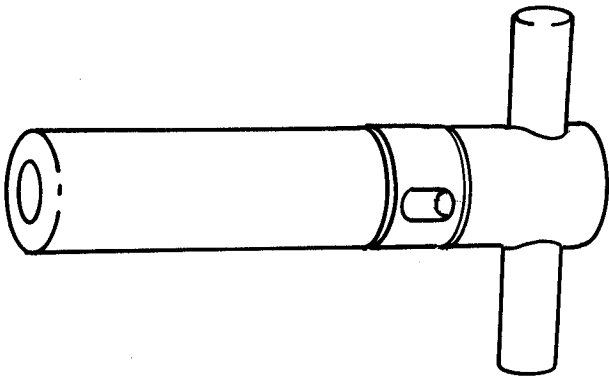

FIG. 4.52-CHECK INPUT SHAFT

NOTE: Rotor and ball-pistons must be replaced as a matched set. The ball-pistons are selected to fit their own individual bores electronically from .0002" to .0006" clearance.

8. Examine pintle (valve body) assembly externally for any damage. If any damage is evident on the shaft portion that passes through the rotors re-check inside both rotors for possible related damage. Check bearing in output shaft end for possible damage or excessive wear and replace as necessary. (Bearing can be removed by hydraulic shunt.)

NOTE: Do not remove the two pipe plugs at the other end of the pintle shaft, they are solid body plugs.

9. It is usually not necessary to remove the charge relief valve located in the outer circumference of the pintle as shown in Fig. 4.56, to remove it, remove plug, No. 1, Fig. 4.56. Inspect spring, No. 2, for bends. Inspect ball, No. 3, and seat in pintle for pitting or grooves.

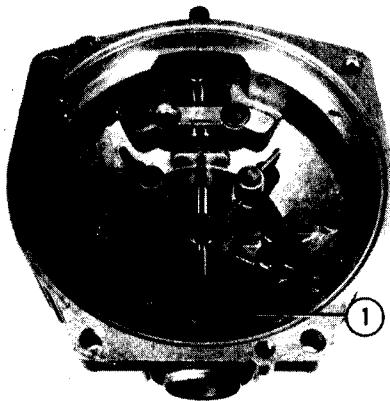

FIG. 4.53-CAM RING & CONTROL SHAFT

1. Cam Ring Dowel Pin.

10. It is usually not necessary to remove the two check valves located in pintle bores as shown in Fig. 4.57. The check valve balls must roll free in the pintle bore by their own weight. If the pintle is shaken the balls can be heard if they are rolling free. To remove the check valves proceed as follows:

- a. Remove spiral pin, No. 1, Fig. 4.58.
- b. Using a tap as shown in Fig. 4.58, tap the hole in the valve bodies and use a bolt or puller to withdraw valve bodies from bores.
- c. Remove balls and inspect for pitting or grooves.

d. Fig. 4.59 shows check valves removed, No. 1, spiral pin, No. 2, retaining rings, No. 3, balls, No. 4, valve bodies.

11. The acceleration valves will not normally require service. They are located in the pintle circumference 180 degrees from the check valves as shown in No. 1, Fig. 4.60.

NOTE: The check valves must be removed before the acceleration valves can be removed.

To remove proceed as follows:

- a. Remove check valves.
- b. Remove pin, No. 2, Fig. 4.60
- c. Obtain a 3/16" rod about 8" long and insert it through the check valve passageways in the pintle.

d. Tap lightly on the rod to push out balls, valves and springs.

e. Removed components are shown in Fig. 4.61, No. 1, springs, No. 2, valves, No. 3 balls and No. 4, retaining pin.

12. Remove and check dampening pistons if necessary. They are located as shown in Fig. 4.62. To remove, hold pintle with pistons away from you and facing down. Tap outside edge of pintle on work bench firmly being careful not to strike shaft portion on anything. If this does not dislodge pistons, they more than likely do not need service. But, if they are scored on the surface and need replacement, they may be removed by cementing a bolt to the face of the piston as shown in Fig. 4.62 and pulling straight out. The pistons are reversible, however the "O" rings and back-up rings on the pistons must be installed so that the back-up rings are toward the outside.

13. Inspect motor rotor and ball-pistons for damage in the same manner as the pump rotor.

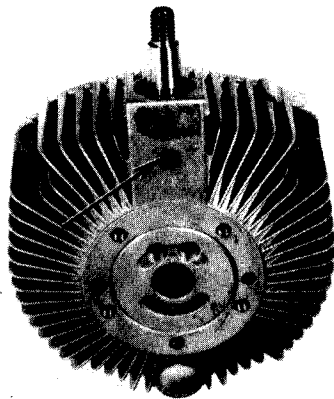

FIG. 4.54-CONTROL SHAFT PIN LOCATION

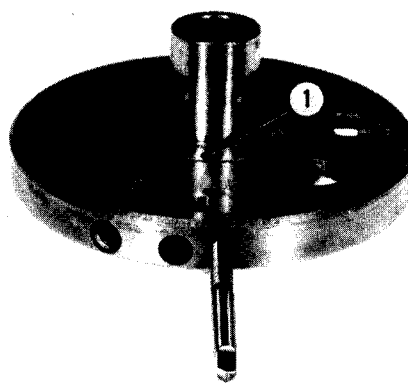

FIG. 4.58-SPIRAL PIN REMOVED

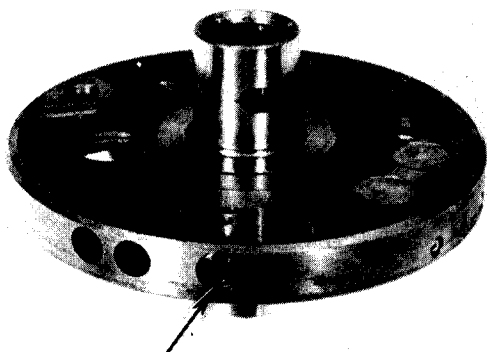

FIG. 4.55-CHARGE RELIEF VALVE LOCATION

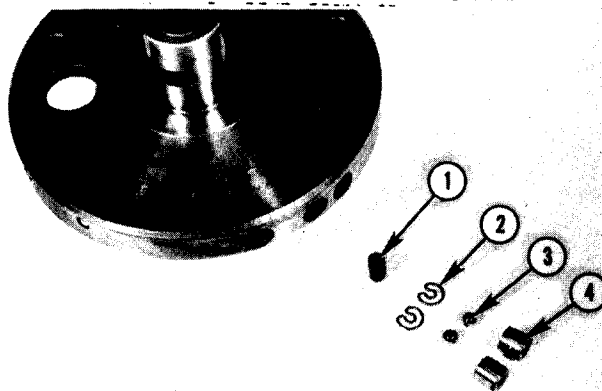

FIG. 4.59-CHECK VALVE PARTS
1. Valves. 2. Rings. 3. Balls. 4. Bodies.

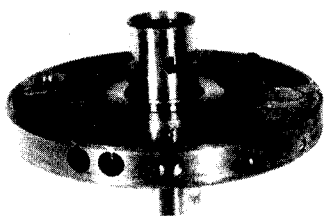

FIG. 4.56-RELIEF VALVE PARTS
1. Plug. 2. Spring. 3. Ball

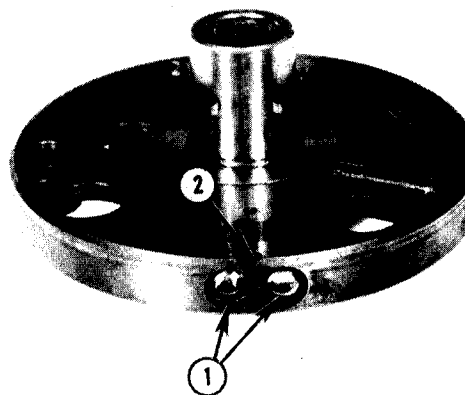

FIG. 4.60-ACCELERATION VALVE (2) LOCATION
1. Check Valves. 2. Acceleration Valves.

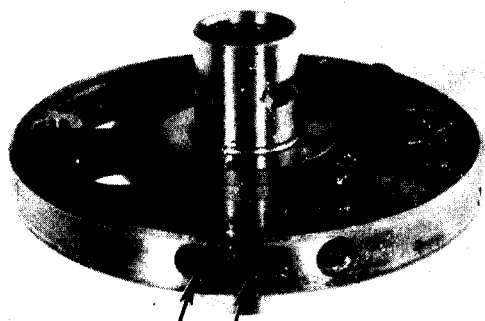

FIG. 4.57-CHECK VALVE LOCATION (2)

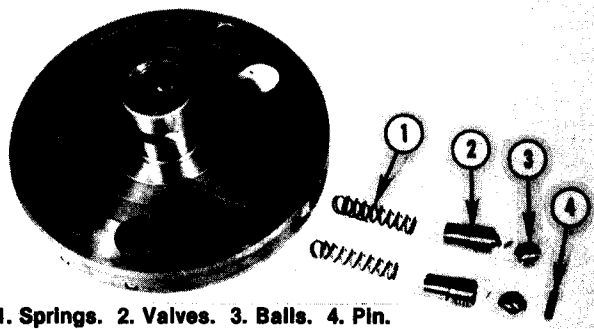

FIG. 4.61-ACCELERATION VALVE PARTS

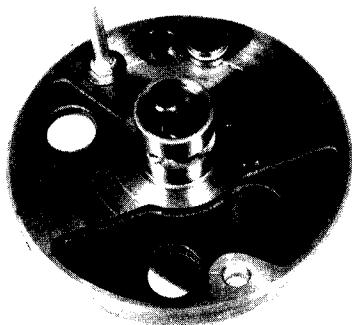

FIG. 4.62-PINTLE DAMPENING PISTONS

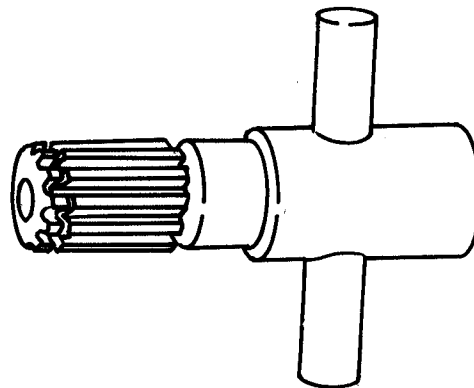

FIG. 4.64-CHECK OUTPUT SHAFT ASSEMBLY

14. Inspect motor ball-piston race, Fig. 4.63, in cast iron body for possible damage and replace if necessary using suitable puller and press.

15. Inspect output shaft assembly, Fig. 4.64 and replace if damaged or excessively worn. It is a slightly press fit in the bearing and can be removed by tapping inward. The shaft cannot be reinstalled without using Tool No. 1145, however, the output shaft bearing must be removed to permit usage of tool.

To remove bearing, remove retaining ring, No. 1, Fig. 4.65 and tap bearing out. The oil seal, No. 1, Fig. 4.66 is located inboard from the bearing and its lip must be positioned toward the inboard. After output shaft is installed support the inboard end on a block of wood and reinstall bearing.

After transmission has been completely reassembled it must be filled with oil before reinstalling in Tractor.

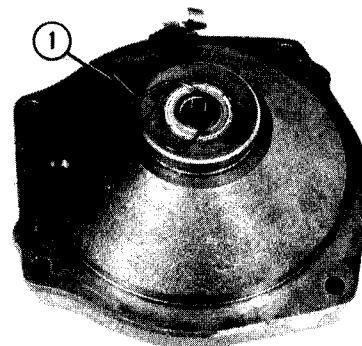

FIG. 4.65-OUTPUT SHAFT BEARING

1. Output Shaft Bearing Retaining Ring.

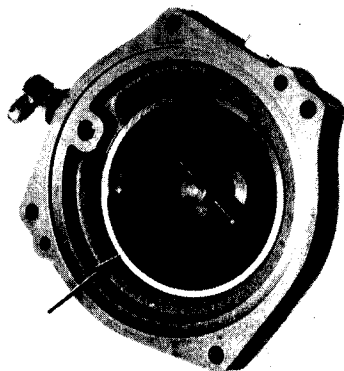

FIG. 4.63-CHECK MOTOR BALL PISTON RACE

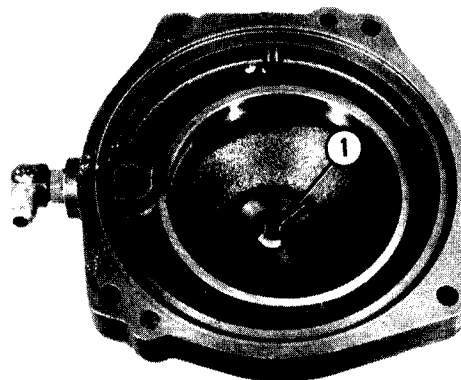

FIG. 4.66-OUTPUT SHAFT OIL SEAL

1. Oil Seal In Place.

SECTION 5 - HYDRAULIC LIFT SYSTEM

The hydraulic lift system on tractors with hydrostatic drives includes the hydraulic control valve located under the right rear fender, the mid-mount implement lift cylinder on the right side of the frame approximately under the instrument panel and the rear PTO attachment lift cylinder on the left rear side of the frame. Hydraulic pressure for the lift system is supplied by the transmission charge pump indicated by the arrow in figure 5.1.

Normal operating pressure for the hydraulic lift system should be in the 700 to 800 psi range. If too low, the cylinders will not lift properly. If too high, seal leakage will eventually occur. A 0-1000 psi pressure gauge and a Tee fitting of appropriate size are needed for checking pressure in the hydraulic lift system. To check the pressure, proceed as follows.

1. Remove center console cover.
2. With engine off, disconnect hose fitting from charge pump (see figure 1) and install Tee fitting then reconnect hose to Tee fitting.

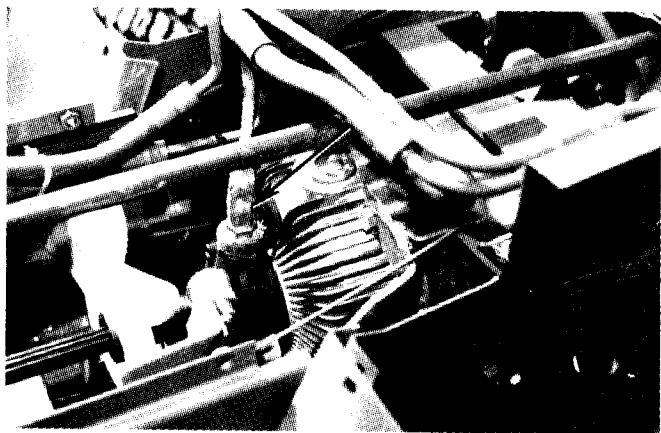

FIG. 5.1--CHARGE PUMP HOSE FITTING.

3. Connect the pressure gauge to the Tee fitting.
4. Start tractor engine and activate lift lever until relief valve "pops" then hold lever and observe pressure on gauge.
5. If the pressure is considerably higher than 800 psi or lower than 700 psi, readjust as described in step 6.
6. Pressure adjustment is made on the adjuster of the control valve as shown in figure 5.2. Loosen the jam-nut and turn setscrew in clockwise direction to increase pressure or in opposite direction to decrease the pressure. When pressure is in the correct range, hold setscrew and tighten the jam-nut to lock in the new setting. Stop engine and remove Tee fitting and reconnect hose to charge pump.

NOTE: If the pressure can not be corrected by readjusting, remove and recondition the control valve as described in the follow.

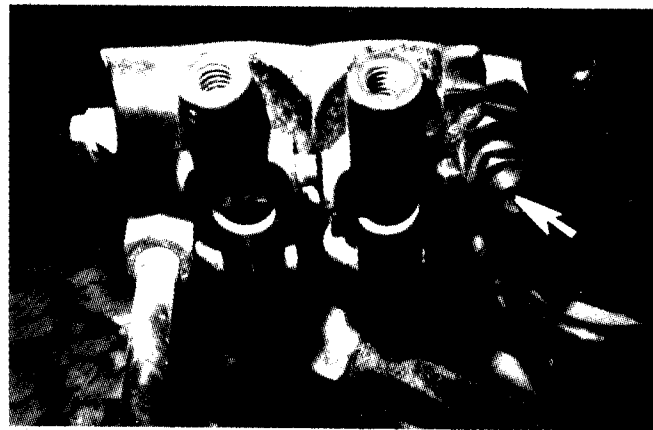

FIG. 5.2--CONTROL VALVE PRESSURE ADJUSTER.

CONTROL VALVE

Complete access to the control valve is gained by removing the rear fender-seat assembly. To remove the control valve for reconditioning, disconnect the hydraulic lines as shown in figure 5.3 and remove the three bolts securing the valve body to the mounting bracket. Reverse this procedure when reinstalling the reconditioned control valve.

RECONDITIONING CONTROL VALVE

Three tie bolts hold the valve bodies together. If a spool or body is damaged, replace the complete valve body. Always use new O-rings and shims. These are supplied in kit form which is listed along with other repair kits in the hydraulic section of the tractor parts manuals. Separate the valve bodies as follows:

1. Stand the control valve on the heads of the three tie-bolts and remove the nuts and washers from the tie-bolts. The plates and bodies are identified in figures 5.5. and 5.6.

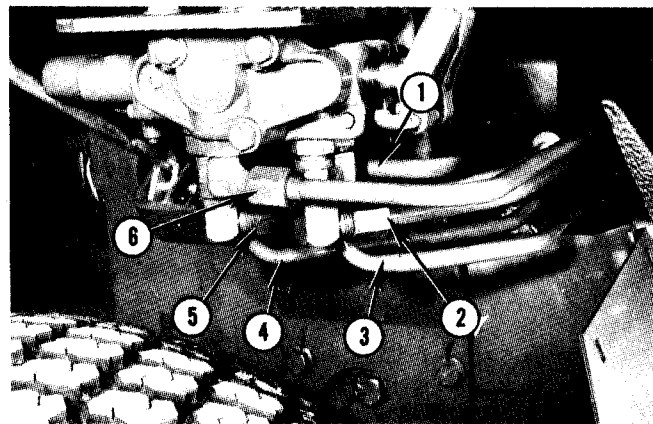

FIG. 5.3--CONTROL VALVE LINE CONNECTIONS.

1. Pump inlet. 2. Rear lift cylinder. 3. Mid lift cylinder.
4. Mid lift cylinder. 5. Rear lift cylinder. 6. Outlet line.

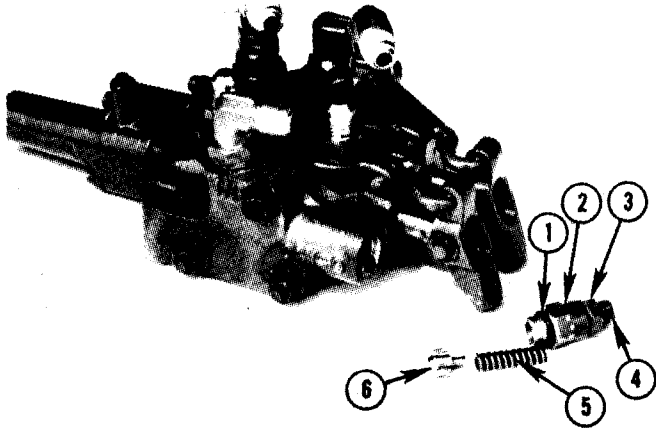

FIG. 5.4--PRESSURE RELIEF & ADJUSTER VALVE PARTS.

1. O-ring. 2. Relief body. 3. Jam-nut.
4. Adjuster. 5. Relief spring. 6. Valve

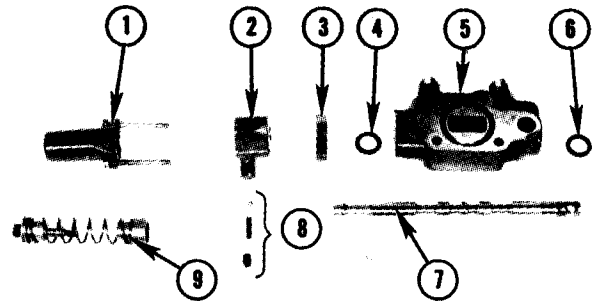

FIG. 5.7--MID MOUNT LIFT VALVE PARTS.

1. Cap. 2. Detent Housing. 3. Spacer.
4. O-Ring. 5. Body. 6. O-Ring.
7. Spool 8. Detent Assembly. 9. Spring & Retainer.

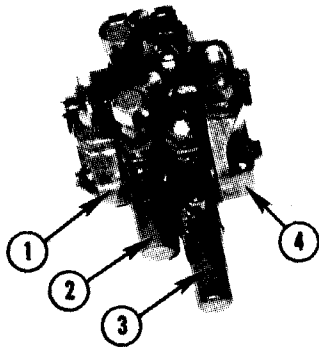

FIG. 5.5--MAIN COMPONENTS ASSEMBLED.

1. Outlet Plate. 2. Three point lift valve.
3. mid-mount lift valve. 4. Inlet Plate.

2. Remove the inlet plate. Note the clear mylar shims --during reassembly the shims must be replaced in exact same quantity and sequence.

3. Remove the three O-rings from the mid-mount linkage valve body then separate this body from the hitch valve body. Again note sequence of mylar shims between the bodies.

4. Remove O-rings and separate the 3-point hitch body from the outlet plate. Note sequence of mylar shims for reassembly.

5. The adjuster valve components are shown disassembled in figure 5.4. Remove and replace these parts from the outlet body if required. Service valve bodies as follows.

VALVE BODY SERVICE: Refer to figure 5.7 for components of the mid-mount lift valve and figure 5.8 for the three-point hitch control valve components. Disassemble and recondition the valve bodies as follows.

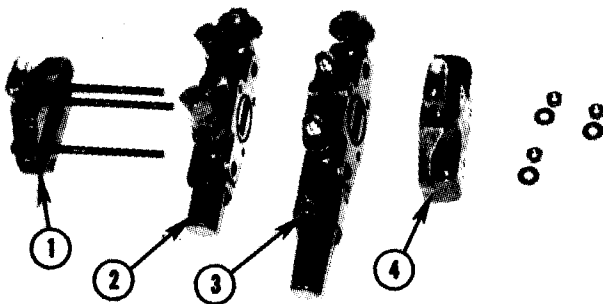

FIG. 5.6--MAIN COMPONENTS SEPARATED.

1. Outlet Plate. 2. Three point lift body.
3. Mid mount lift body. 4. Inlet plate.

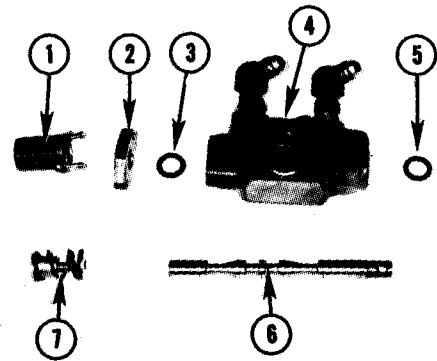

FIG. 5.8--3 POINT HITCH LIFT VALVE PARTS.

1. Cap. 2. Spacer. 3. O-ring. 4. Body.
5. O-ring. 6. Spool. 7. Spring & Retainer.

1. Remove end cap retaining screws and pull the cap.
2. Use allen wrench to remove spring retainer - be careful not to let the spring fly loose as the retainer separates.
3. On mid-mount valve assembly, remove the setscrew from the detent housing and pull the detent assembly parts (item 8, figure 5.7).
4. Remove retainer from control handle pin then remove handle and "S" hook.
5. Push spool out toward rear of valve body then remove the O-rings from both sides of the body.
6. Carefully inspect spools and bodies and replace if worn or damaged. Use new O-ring seals and shims. Reverse the foregoing steps to reassemble and reinstall the reconditioned control valve to the tractor. Adjust pressure as described earlier.

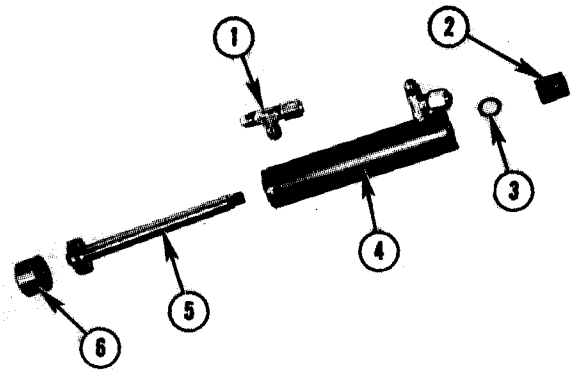

FIG. 5.10--TYPICAL LIFT CYLINDER PARTS

1. Fitting. 2. Fitting. 3. Seal. 4. Barrel.
5. Piston and rod. 6. Plug with seal.

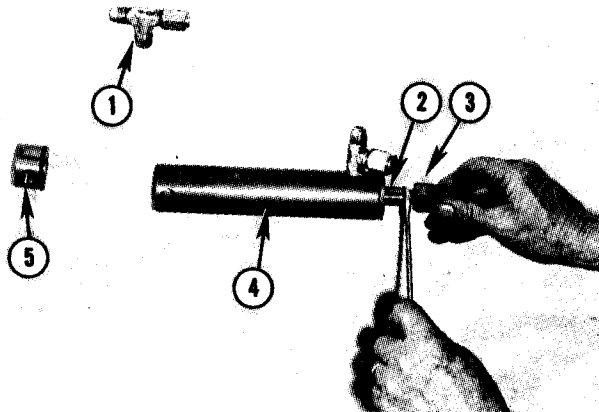

FIG. 5.9--DISASSEMBLY OF TYPICAL LIFT CYLINDER

1. Fitting. 2. Piston Rod. 3. Fitting.
4. Cylinder Barrel. 5. Plug.

LIFT CYLINDER RECONDITIONING

Several different types of lift cylinders are used. Refer to the parts manual for identification of the types used. While the following steps apply specifically to one type of lift cylinder, the same general procedure should be used in reconditioning all type lift cylinders after removal from the tractor.

1. Remove the fitting from the plug end of the cylinder and remove the hitch fitting from the piston rod (Figure 5.9).
2. Using a soft face mallet and punch, gently drive the piston shaft inward until the plug (item 6, figure 5.10) can be removed from the end of the cylinder barrel. Be careful to avoid damaging threads on piston rod when doing this.
3. Push the piston and rod out of the cylinder barrel.

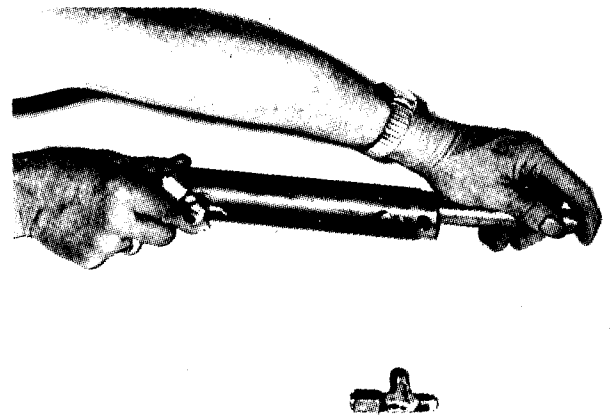

FIG. 5.11--INSTALLING PLUG AND SEAL

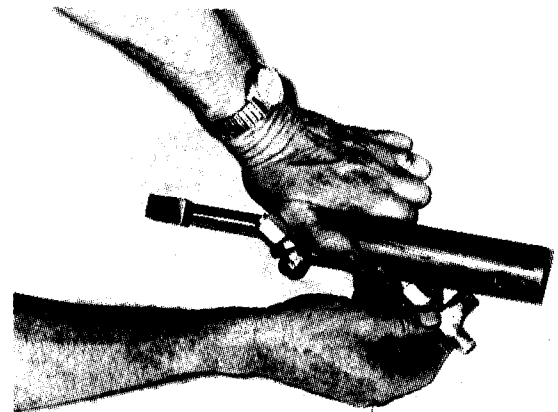

FIG. 5.12--INSTALLING PLUG END FITTING

4. Service the cylinder barrel as follows. Clean all paint off and remove burrs specifically in area around attachment pin holes. Using a small screwdriver or sharp point pick, pry and remove the dust seal at the piston rod end of barrel. Also remove the O-ring at the rod end. Replace the dust seal and O-ring with new parts.

5. Replace the piston O-ring, lightly lubricate the piston then carefully guide it into the barrel being careful not to damage the O-ring as it passes the holes inside the barrel. Use a lightly lubricated sleeve over threaded end of the barrel to prevent damage to the barrel end dust seal and O-ring.

6. Lightly lubricate the plug end replacement O-ring and install in plug then reinstall plug in barrel. Note: Make sure that threaded fitting hole in plug lines up with fitting hole in barrel and be careful not to damage O-rings on plug when they pass by the holes in the barrel.

7. Reinstall fitting in plug end of cylinder then hitch fittings before reinstalling reconditioned cylinder in tractor.

SECTION 6 - ENGINE SERVICE & REMOVAL

Since extensive repairs and overhaul of the engine are to be handled by dealers authorized to do so by the engine manufacturer, only certain routine service adjustments plus the procedures for removing and reinstalling the engines are covered in this section. The procedures differ in certain areas for the single and twin cylinder engines and are covered separately in this section.

ENGINE TROUBLE SHOOTING GUIDE

HARD STARTING OR LOSS OF POWER

1. Faulty ignition. (See Section 7).
 - a. Leads grounded or loose.
 - b. Breaker points faulty or improperly gapped.
 - c. Spark plug faulty or improperly gapped.
 - d. Coil or condenser defective.
2. Faulty Carburetion.
 - a. Fuel line or filter clogged (dirt, gum, etc.).
 - b. Fuel pump faulty.
 - c. Carburetor dirty or improperly adjusted.
3. Poor compression.
 - a. Head loose or gasket leaking.
 - b. Valves sticking or leaking.
 - c. Piston rings worn.

WON'T START

Check interlocks switches. (See Section 7).

1. If engine won't crank check neutral return brake pedal, rear PTO switch and circuit breaker.
2. If engine cranks but does not start check seat switch.

OPERATING ERRATICALLY

1. Clogged fuel line.
2. Water in fuel.
3. Vent in gas cap plugged.
4. Faulty fuel pump.
5. Gasket leaking (carburetor-manifold).
6. Governor improperly set.
7. Carburetor improperly adjusted.

KNOCKING

1. Fuel octane too low.
2. Ignition timing wrong.
3. Carbon build-up in combustion chamber.
4. Engine overheated.

OCCASIONAL SKIP AT HIGH SPEED

1. Spark plug fouled, faulty or gap too wide.
2. Ignition timing wrong.
3. Carburetor improperly adjusted.
4. Breaker points faulty or improperly adjusted.

OVERHEATING

1. Air intake screen or fins clogged.
2. Oil level too high (or low).
3. Fuel mixture too lean.
4. Ignition timing wrong. Spark too far advanced.
5. Engine overloaded.
6. Tappet clearance too close.

IDLES POORLY

1. Idle speed too low.
2. Idle fuel improperly adjusted.
3. Gasket leaking (carburetor-manifold).
4. Spark plug gap too close.

BACKFIRING

1. Carburetor set too lean (main fuel).
2. Breaker points improperly gapped (timing).
3. Valve sticking.

CARBURETOR ADJUSTMENTS

Lack of power and black sooty exhaust smoke usually indicates that fuel mixture is too rich. An overrich mixture may also be caused by a clogged air cleaner — check this before readjusting carburetor. Fuel mixture may be too lean if engine skips or backfires at high speed.

SINGLE CYLINDER ENGINES

MAIN FUEL: For preliminary setting, turn main fuel screw, in clockwise direction until it bottoms lightly (do not force) then back out two turns. With engine thoroughly warmed up and running at full throttle and full load, turn main fuel screw in until engine slows (lean setting) then turn screw out until engine regains speed and then starts to slow down (overrich setting). Turn screw back in until it is positioned halfway between lean and overrich settings — when properly adjusted engine will accelerate smoothly and operate with steady governor action.

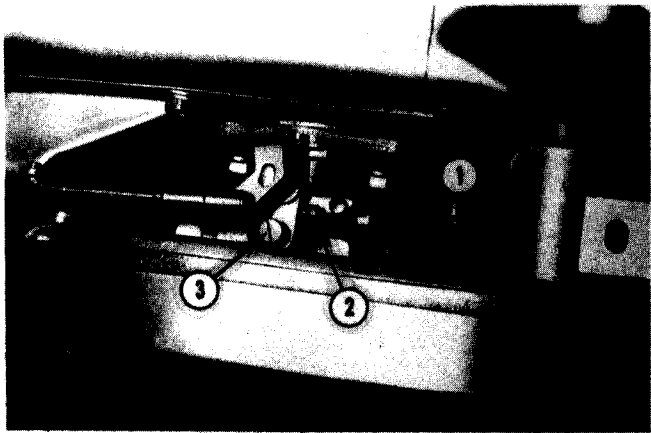

FIG. 6.1-CARBURETOR-SINGLE CYL.

1. Idle Fuel. 2. Idle Speed. 3. Main Fuel.

IDLE ADJUSTMENT: Rough idle is usually caused by idle speed being set too low. Turn idle speed screw, in clockwise direction to increase speed. If engine still idles poorly after speed is increased, stop engine and turn idle fuel screw all the way in (clockwise) until it bottoms lightly (do not force screw), then back out 1-1/4 turns. Restart engine and check idle — turn needle in or out (1/4 turn at a time) until smoothest idle is achieved. Idle speed should be 2100-2300 rpm.

TWIN CYLINDER ENGINES

1. Stop engine, remove hood from Tractor and turn both fuel mixture screws in until they bottom (do not force).

2. Turn high speed mixture screw out two turns and turn idle mixture screw out one turn. This is an initial setting.

3. Start engine and run at full throttle (do not exceed 3650 rpm), turn high speed mixture screw in until engine starts to slow down. Then turn screw out slowly until engine regains full speed. If adjusted properly, engine should accelerate smoothly and operate at a steady governor speed. If it doesn't open adjustment screw slightly.



FIG. 6.2-CARBURETOR ADJ-TWO CYL.

1. Spark Plug. 2. Breaker Point Case.
3. Idle Mixture. 4. High Speed (Main) Fuel Mixture.

4. Operate engine at about 1200 rpm and turn idle mixture screw in until engine slows down (runs rough) then open screw until engine runs smooth.

5. Reset idle speed to 1800-2000 rpm.

NOTE: If these adjustments do not correct carburetor problems, carburetor should be removed and overhauled.

GOVERNOR ADJUSTMENT

The governor functions to maintain engine speed under changing load conditions and also acts as a speed limiting device. Governors are set at the factory and further adjustment should not be required unless linkage works loose or becomes disconnected. Readjustment should be made if engine surges with changing load or if speed drops considerably when a normal load is applied.

SINGLE CYLINDER ENGINES

INITIAL ADJUSTMENT: With engine stopped, loosen (do not remove) hex nut, securing governor arm, to governor cross shaft. Grasp end of cross shaft with pliers and turn shaft as far as possible in counterclockwise direction — tab on shaft will stop internally against governor gear mechanism. Hold shaft in this position, pull governor arm all the way away from carburetor then retighten governor arm nut to complete initial adjustment.

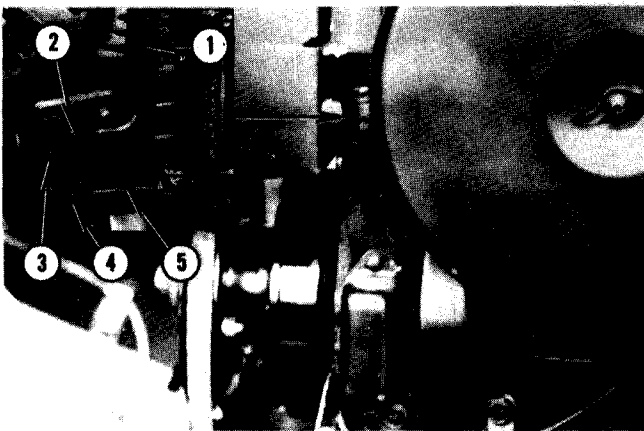

FIG. 6.3-GOVERNOR ADJ-SINGLE CYL.

1. Governor Arm.
2. Cross Shaft.
3. Hex Nut.
4. Governor Control Bracket.
5. Governor Spring.

SPEED ADJUSTMENT: Maximum allowable speed is 3600 rpm. This speed must not be exceeded. If overspeed condition is suspected, check rpm's with hand tachometer and readjust as follows:

Adjust high speed stop screw, until correct maximum speed is attained.

SENSITIVITY: If speed drops considerably when a normal load is applied, governor should be set for greater sensitivity. If set too sensitive, speed surging will occur when changing load. Governor sensitivity is adjusted by repositioning governor spring, in holes provided on governor control bracket, and

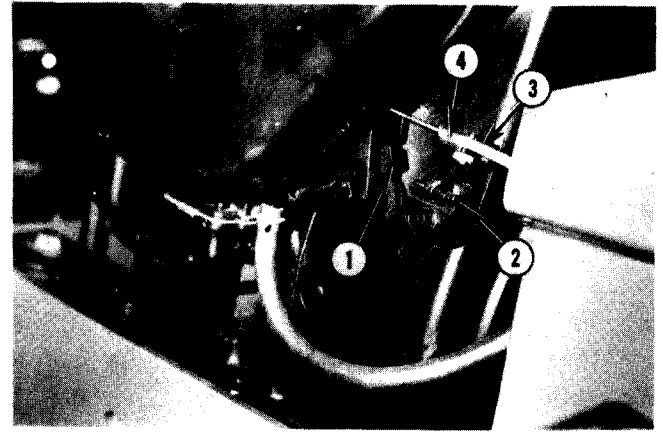

FIG. 6.4-SPEED ADJUSTMENTS-SINGLE

1. High speed Bracket.
2. High Speed Stop Screw.
3. Throttle Control Cable.
4. Choke Cable.

speed bracket. Increase tension on spring (and sensitivity) by moving spring hooks into holes spaced further apart — conversely, decrease sensitivity by reducing tension on spring.

TWIN CYLINDER ENGINES

To adjust high speed setting (no load governed speed): Position set screw on end of throttle control bellcrank so that when control lever on dash is in forward position rearward arm of bellcrank is against stop of fixed bracket. This should provide 3600 rpm engine speed. If it does not bend stop pad to achieve 3600 rpm. It may be necessary to reposition throttle control wire in set screw on bellcrank.

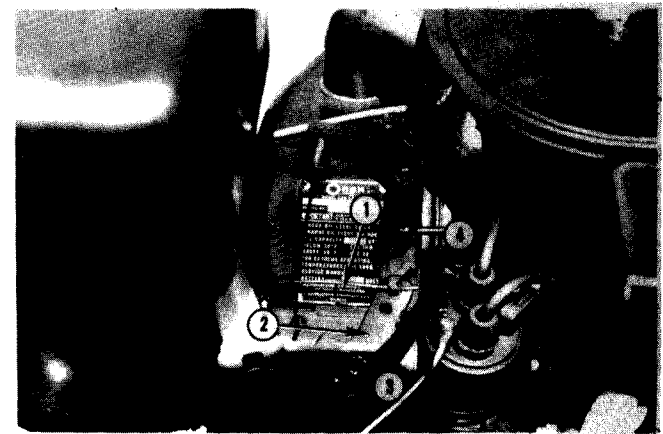

FIG. 6.5-SPEED ADJUSTMENTS-TWO CYL.

1. Throttle Control Cable.
2. Throttle Control Bellcrank.
3. High Speed Stop Pad.
4. High Speed Adjustment Screw.

ENGINE REMOVAL & INSTALLATION

REMOVAL - SINGLE CYLINDER

Refer to figures 6.6 and 6.7.

1. Remove hood and grille assembly.
2. Disconnect battery cables and electrical wires from engine.
3. Disconnect cable from starter motor.
4. Shut off fuel and remove line from carburetor.
5. Disconnect choke and throttle cables from engine.
6. Remove battery ground cable bolt from battery platform.

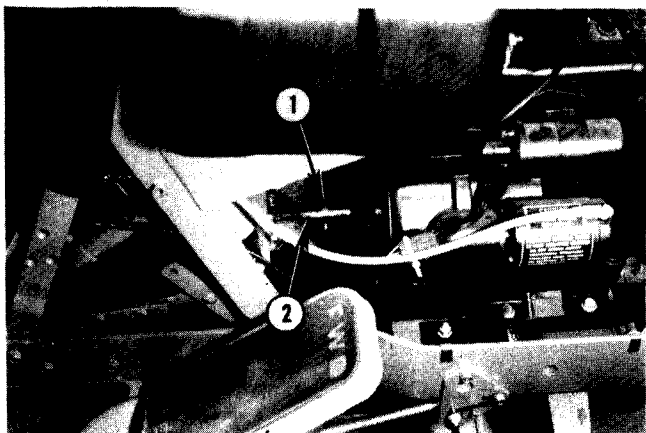

FIG. 6.6-COUPLER PIN & SLEEVE

1. Coupler Pin. 2. Coupler Sleeve.

7. Remove pin from drive coupler and slide coupler sleeve rearward.
8. Remove engine mounting bolts and lift engine out.

INSTALLATION - SINGLE CYLINDER

1. Position engine on frame and secure with retaining bolts.
2. Reconnect cables, wires and fuel lines.
3. Slide drive coupler onto engine shaft and secure with pin.
4. Install hood and grille assembly.

REMOVAL - TWIN CYLINDER

1. Remove hood and grille assembly.
2. Remove right side panel to gain access to tractor belt tension adjustment.
3. Disconnect battery cables.
4. Close fuel tank shut-off, disconnect fuel supply line from fuel pump and remove fuel tank.
5. Disconnect electrical wiring (alternator wire) at right rear of engine and remove harness clamp bolt.

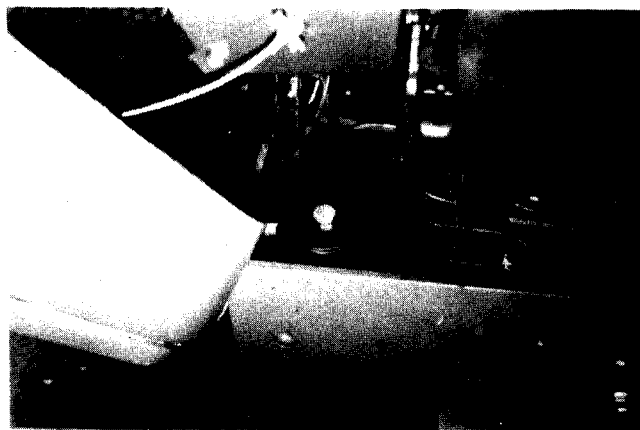

FIG. 6.7-MOUNTING BOLT-SINGLE CYL.

6. Loosen traction belt tension by turning nuts at lower portion of rod and remove pin from end of rod.
7. Remove traction belts.
8. Remove retaining clip from traction drive belt tension bracket.
9. Remove complete exhaust system and disconnect throttle and choke cables from engine.
10. Remove pin and slide coupling rearward on PTO shaft if equipped.
11. Disconnect battery cable from starter motor.
12. Disconnect ignition wire from ignition coil.

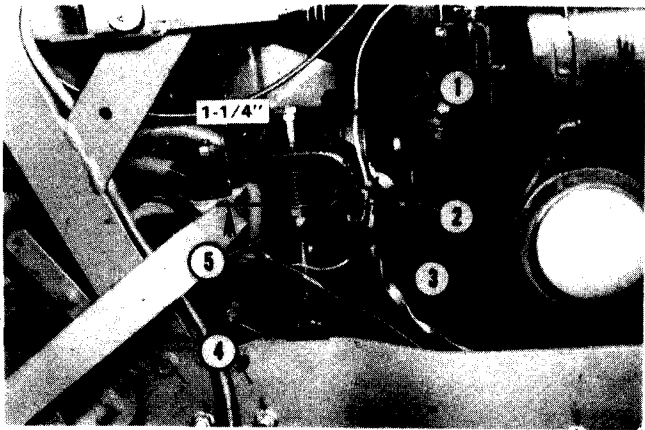

FIG. 6.8-TRACTION DRIVE-TWO CYL.

- 1. Traction Drive Belts. 2. Alternator Wiring.
- 3. Clamp Bolt. 4. Pin. 5. Belt Tensioning Nuts.

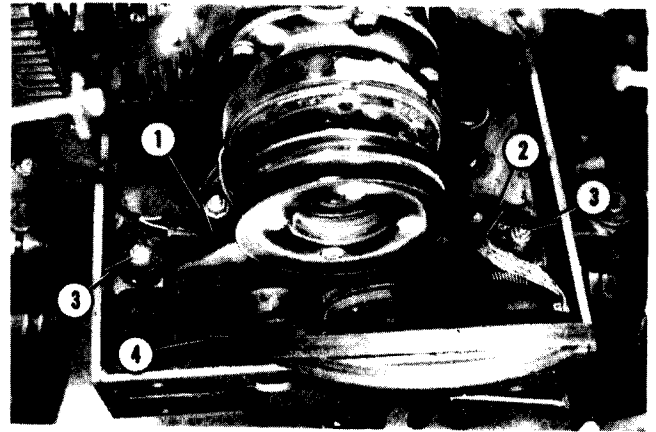

FIG. 6.11-ENGINE MOUNTING DETAIL

- 1. Electric Clutch Wire. 2. Grounding Strap.
- 3. Mounting Bracket Nuts. 4. PTO Drive Belts.



FIG. 6.9-TENSION BRACKET RETAINING CLIP

13. Disconnect electric clutch wire (blue wire) at right front of engine.

14. Remove front PTO drive belts.

15. Disconnect ground strap and remove engine mounting bracket nuts at front of engine.

16. Drain engine oil and remove drain pipe.

17. Remove nuts at rear of engine mounting brackets.

18. Attach a suitable lifting device and raise engine just enough to clear mounting studs.

19. Slide traction drive tension bracket from its pivot post while moving engine forward. Continue lifting engine clear



FIG. 6.10-DRIVE COUPLER & PIN

- 1. Twin Cylinder Engine Coupler. 2. Throttle Cable.

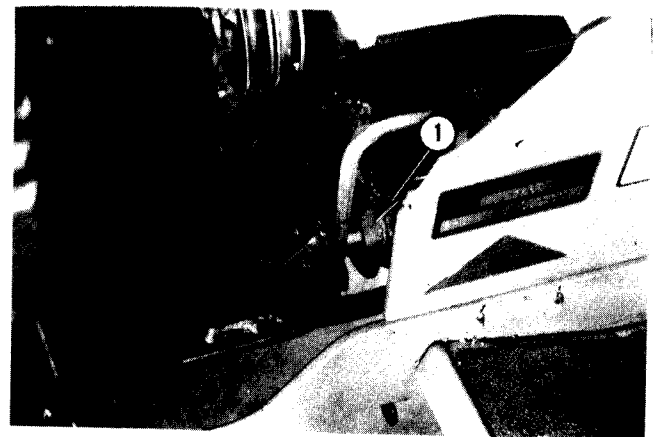

FIG. 6.12-TRACTION DRIVE TENSION BRACKET

- 1. Drive Tension Bracket — Twin Cylinder.

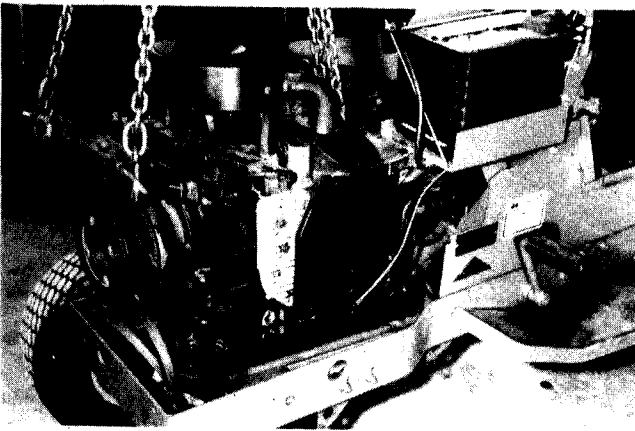

FIG. 6.13-LIFTING OUT OF FRAME

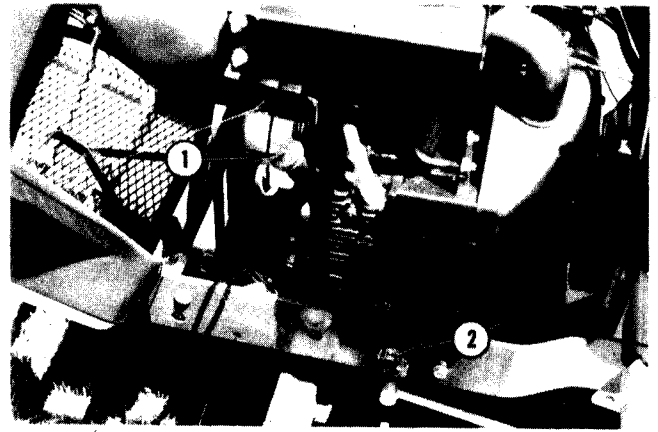

FIG. 6.14-ENGINE REINSTALLED

1. Oil Fill Tube. 2. Oil Drain Tube.

INSTALLATION - TWIN CYLINDER

1. Position engine in place, start tension bracket over pivot post at same time.
2. Continue aligning mounting brackets with studs and secure engine in place with retaining nuts.
3. Reconnect the following:
 - a. Ground strap
 - b. Ignition wire to coil
 - c. Electric clutch wire
 - d. Cable to starter motor
 - e. Throttle cable
 - f. Alternator wire at right rear of engine
4. Install choke

5. Install retaining clip on tension bracket post.
6. Install exhaust system.
7. Slide PTO coupling (if equipped) forward on engine shaft and secure with pin.
8. Install traction drive belts and insert pin at lower end of belt tension rod.
9. Adjust belt tension nut until length of spring is 1-1/4" and secure with lock nut.
10. Install front PTO drive belts.
11. Install oil drain pipe and fill engine with oil.
12. Install fuel tank and reconnect battery cables.
13. Install hood and grille assembly.

SECTION 7 - ELECTRICAL SYSTEM

IGNITION - GENERAL SERVICES

SPARK PLUGS: Remove and check condition every 100 hours of operation or annually. If gapping is needed, set at .035". Do not sandblast, wire brush or scrape plug. If needed, replace with Champion RH 10.

BREAKER POINTS: Check and service at least every 100 hours of operation or annually. If oxidized, oily or dirty, clean with a coarse cloth. Do not use emery cloth or sandpaper. Replace badly pitted or burned points. To adjust, turn engine over by hand until points are at maximum opening. Check gap with feeler gauge. If gap is not .020", loosen retaining screw and shift plate until proper gap is obtained. Retighten screw, then recheck gap when points are fully open. Replace condenser if necessary.

IGNITION SWITCH: Ignition switch is key operated and is on right lower portion of instrument panel. It has four positions; off, run with lights, run and start. Turning key to start cranks starter motor. When key is released, it returns to run position. Turning key one notch to left of "Run" turns on lights. Turning key one more notch to left shuts off engine.

AMMETER: Ammeter is on left side of instrument panel. Normally needle will be on right (plus) side of dial when engine is running, indicating alternator's rate of charge. If ammeter indicates a discharge (with needle on (minus) side of dial) for any length of time, check wiring, battery and circuit breaker for shorts or other malfunctions.

HOURMETER — (ACCESSORY): Hourmeter indicates accumulated hours of engine operation.

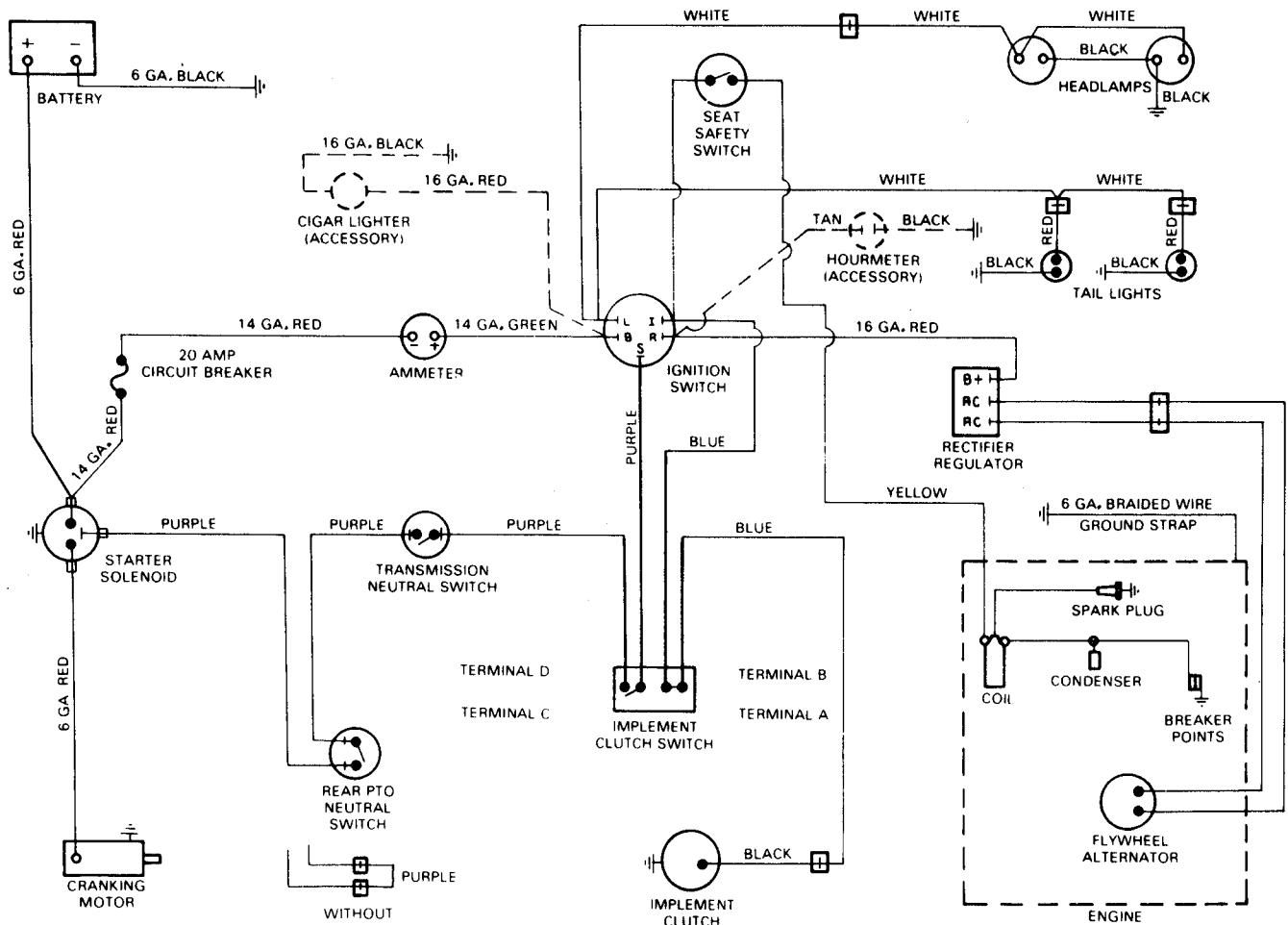

NOTE All wires 18 gauge unless otherwise specified.

FIGURE 7.1--GARDEN TRACTOR SCHEMATIC WIRING DIAGRAM

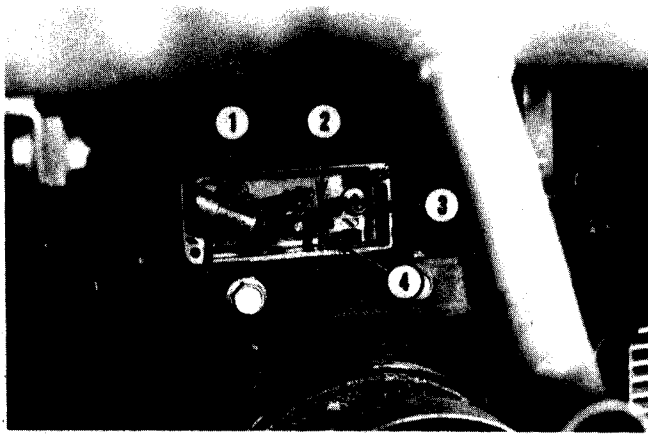

FIG. 7.2--BREAKER POINTS-2CYL.

1. Condenser. 2. Breaker Points.
3. Retaining Nut. 4. Plunger.

INTERLOCK SWITCHES

The function of these switches is to allow the engine to start when the following starting conditions exist.

1. Operator seated in tractor's seat.
2. Clutch/Brake pedal depressed.
3. Front PTO switch in OFF position.
4. Rear PTO (if tractor so equipped) lever is OFF.

The mechanism controlling condition, No. 1, above is in the engine ignition circuit. The mechanisms controlling conditions, No. 2, 3 and 4, above are in the engine cranking circuit. Therefore, it is important to remember that ALL these starting conditions must exist before the engine will start. Also, if starting conditions, Nos. 2, 3 and 4, exist the engine will crank over using the starter but will not start if starting condition, No. 1, is not existing.

TESTING INTERLOCK SWITCHES:

1. Remove wires from switch, connect test light or ohmmeter to switch terminals.
2. The following results should be obtained.

Switch	Location	Light	Ohmmeter
Seat (with Seat raised)	under seat	off	no reading
Clutch (Pedal down)	above transmission fan	on	reading
Mower Clutch (off)	disconnect purple wires at switch	on	reading
Rear PTO (off)	under left fender above drive shaft	on	reading

CIRCUIT BREAKER

The electrical system is protected by a 20 AMP circuit breaker which is mounted on the backside of the instrument panel near the battery.

If this fails, the engine will not start or run. The circuit breaker can not be reset and must be replaced if it fails. When connecting the replacement, make sure the starting solenoid wire is connected to the "BAT" terminal and the positive side of the ammeter is connected to the "AUX" terminal as shown in figure 7.3.

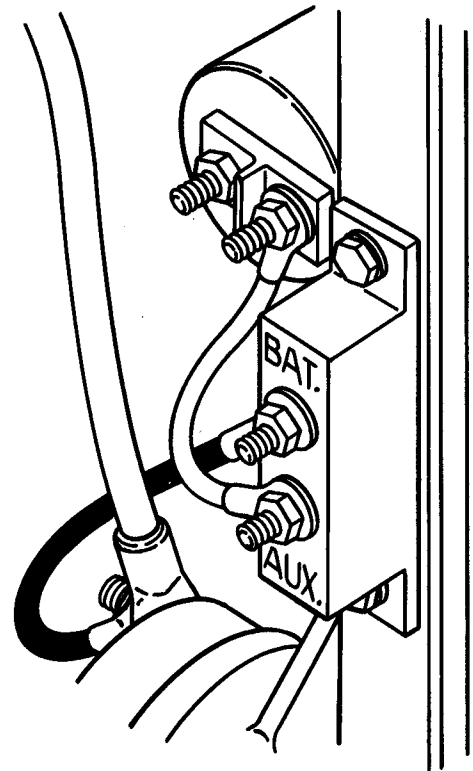

FIG. 7.3--CIRCUIT BREAKER WIRING

1. Remove battery cables, connect an ohmmeter between ammeter terminals and ground. You should get no reading, if a reading occurs ammeter is grounded.

ALTERNATOR CHARGING SYSTEM

PRECAUTIONS:

1. Do not connect battery to cables in wrong polarity. This will cause regulator-rectifier damage.

2. Break continuity between regulator-rectifier unit and battery when using a remote charger on battery or when jumping from another battery. This will eliminate damage to regulator-rectifier if polarity is reversed.

3. Disconnect wiring harness at regulator-rectifier before using arc welder equipment.

PRE-SERVICE CHECKS

1. Check for good ground between regulator-rectifier and mounting.

2. Check for poor connections or broken wires.

TROUBLE SHOOTING

BATTERY CHARGING AT HIGH RATE:

1. Connect DC Voltmeter across battery. If voltage is over 14.7 volts, regulator-rectifier is not functioning. If voltage is under 14.7 volts, battery is defective.

BATTERY NOT FULLY CHARGED:

1. Connect a jumper wire from battery positive terminal to coil positive terminal.

2. Start engine and disconnect B plus wire from circuit breaker (wire going to solenoid)

3. Connect DC Voltmeter positive lead to wire removed from circuit breaker terminal and negative lead to ground. Run engine at full speed and check DC Voltage. Disconnect jumper wire to coil after test is completed.

Volt meter reads:

a. Above 14 volts.	Check alternator. OK ammeter may be defective.
b. Less than 14 volts but above "0" volts.	Defective regulator-rectifier.
c. "0" voltage.	Defective Stator or regulator-rectifier.

4. Reconnect circuit breaker. Start engine and check voltage across battery. If reading is 13.8 volts or more, place a load on battery to reduce voltage to below 13.6 volts. This can be done by turning on lights for a short time.

a. Charging rate increases.	Alternator OK.
b. Charging rate does not increase.	Defective stator or regulator-rectifier.

5. A check to determine if stator or regulator-rectifier is defective, unplug ac leads at regulator-rectifier and connect voltmeter leads in spade connector. Check voltage with engine running at full speed.

a. Less than 20 volts.	Defective Stator.
b. More than 20 volts.	Defective regulator-rectifier.

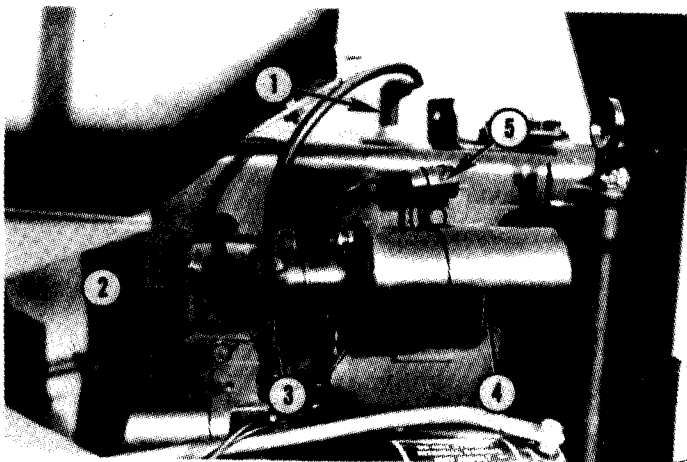

FIG. 7.4--IGNITION-SINGLE CYLINDER

1. Spark Plug 2. Regulator. 3. High Tension Wire.
4. Coil. 5. Condenser.

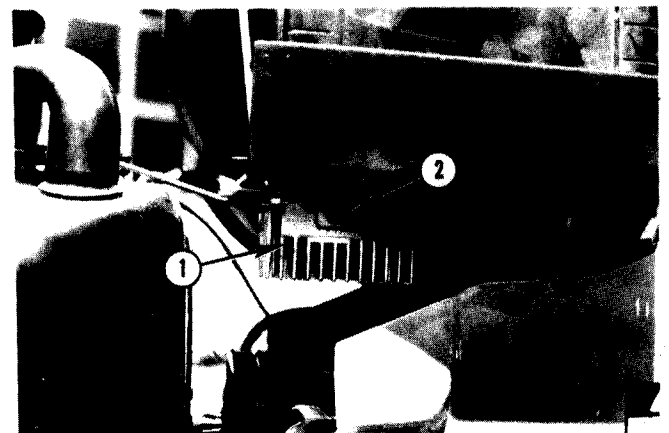

FIG. 7.5--RECTIFIER/REGULATOR-2 CYL.

1. Rectifier-Regulator. 2. Terminal.

SECTION 8 — FUEL SYSTEM

INTRODUCTION

The fuel system on all tractors includes a 2-3/4 gallon tank mounted on a insulator pad on the pedestal frame of the tractor. The capacity is the same for all tanks however the configuration on the 1855 series tank differs from the tank used on both the 1600 and 1650 series. A fuel shut off valve is provided on the outlet of each tank. The fuel line leading to the engine included a replaceable in-line fuel filter. Tilt the tractor hood forward to gain access to the fuel system components. The tank may have to be removed to gain access to components on the backside of the instrument panel and steering shaft in some repairs.

CAUTION: Take necessary cautions when handling fuel system components to prevent ignition of the gasoline! Service and/or replace fuel system components as follows:

FUEL FILTER

The case of the in-line fuel filter is transparent to allow frequent visual checks. The filter should be replaced when water, dirt and/or sediment builds-up inside the case. If excessive build-up is noted, the tank and fuel lines should be cleaned before installing the replacement filter. Replace filter as follows.

STEP 1: Turn the fuel shut-off valve under tank in clockwise direction to full off position.

STEP 2: Using a pair of pliers, compress the ends of the hose clamps above and below the filter and slide the clamps back over the inlet and outlet flanges of the filter.

STEP 3: Pull the fuel inlet hose off the top of the filter then pull the outlet hose of the bottom of the filter. Discard the used filter and install replacement by reversing the foregoing procedure. **NOTE:** The widest part of the filter must be installed down and connected to the outlet hose to the engine.

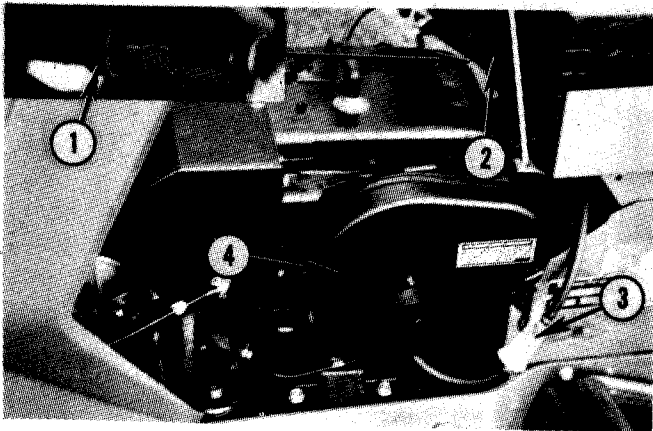

FIG. 8.1 — FUEL SYSTEM (SINGLE CYL.)

1. SHUT-OFF VALVE. 2. FUEL TANK.
3. IN-LINE FILTER. 4. AIR CLEANER.

CAUTION: Check routing of the fuel hoses afterward to make sure they are routed above the throttle cable and away from the rotating grass screen of the engine to eliminate possible cutting later during operation.

FUEL TANK

The fuel tank should be checked at the start of each operational season. If water or dirt is present, the tank and fuel lines should be removed and thoroughly cleaned. Remove tank as follows:

STEP 1: Lift hood and turn fuel shut-off valve under tank in clockwise direction to full off position.

STEP 2: Using a pair of pliers, compress the hose clamp at the valve and slide the clamp downward away from the flange of the valve. Pull the hose off the fuel valve.

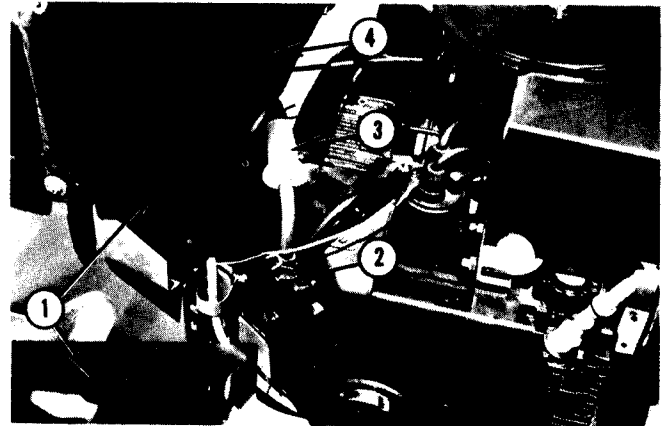

FIG. 8.2 — FUEL SYSTEM (TWO CYL.)

1. SHUT-OFF VALVE. 2. FUEL PUMP.
3. IN-LINE FILTER. 4. FUEL TANK.

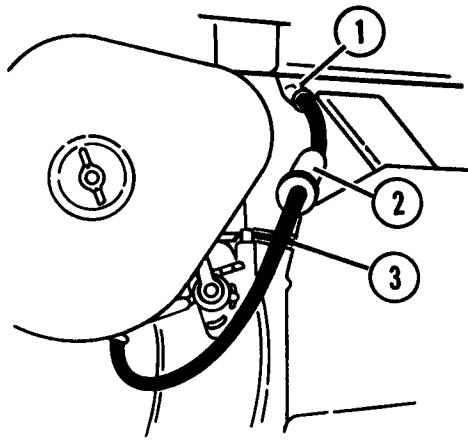

FIG. 8.3 — LINE ROUTING (SINGLE CYL.)

1. TANK OUTLET. 2. FUEL FILTER.
3. THROTTLE & CHOKE CABLES.

STEP 3: Unhook the retaining strap from the tank bail or clamp, lift the bail then remove the tank.

STEP 4: Remove the fuel cap-guage then carefully dispose of the contaminated or stale fuel remaining in the tank. Clean the tank by swishing with clean gasoline. Clean or replace the fuel lines at this time if excessive dirt or water was present.

STEP 5: Before installing the tank, check the bottom and rear side of tank for evidence of rubbing. Replace the vibration insulation pads at rear and bottom if worn also replace tank if worn then at these points. Reverse foregoing procedure to reinstall tank.

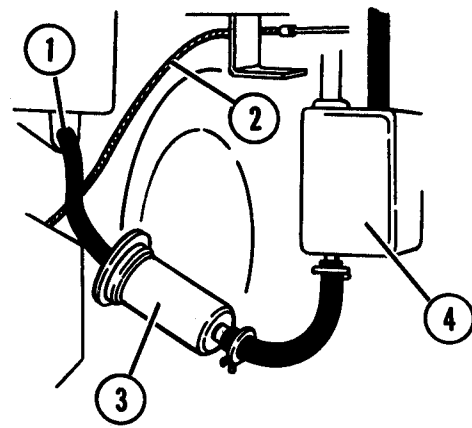

FIG. 8.4 — LINE ROUTING (TWO CYL.)

1. TANK OUTLET. 2. THROTTLE CABLE.
3. FUEL FILTER. 4. FUEL PUMP.

CAUTION: Carefully route the fuel hoses over the throttle cable away from the rotating grass screen on engine to eliminate chances of the screen cutting or wearing thru the hoses during operation.

FUEL LINE ROUTING

Always route the fuel line above the throttle cable as shown in figure 8.1 to prevent the rotating grass screen on the engine from rubbing thru the hoses during operation! This routing will keep the hoses sufficiently away from the screen.

SECTION 10 - MOWERS & DRIVES

Covered in this section are the 42 and 48" mid-mount mowers which are belt driven off a "mule" drive unit attached to the front of the 1600 and 1650 series tractors. Also covered are the gear driven 54" mid-mount mowers used on the 1855 series tractors. Differences are pointed out wherever pertinent in this section.

DETACHING MOWERS

1. Raise mower with mower lift then shut off Tractor engine. Place gauge wheels in full up position.
2. Lower mower to ground.
3. Disconnect four lift links from anchor plates.
4. Disconnect hanger straps and disconnect drive belt from clutch and idler pulleys, on 54" mowers, disconnect PTO shaft from mid PTO.
5. If mounting ramps are used, simply put in place and back Tractor up and over mower.
6. If mower mounting ramps are not used, slide mower out sideways from under Tractor.

REPLACING BELT AND/OR BLADES AND TIMING BLADES

IMPORTANT NOTE

The three blade spindles are in a straight line to prevent leaving a narrow uncut strip between the cutting swath of each blade. There is an overlap relationship between cutting swath of center blade and cutting swath of outside blades. The blades must therefore, be timed so that they do not make contact during rotation. Time blades so that outside blades are parallel to each other while the center blade is perpendicular.

TIMING BELT REPLACEMENT

1. Detach mower from Tractor.
2. Remove belt covers and back off nuts on outboard spindle housing mounting bolts one turn. Tighten nuts on belt tensioning bolts to bring outboard spindles inboard to slacken belts.
3. Remove top belt, then bottom belt. Install new belts in reverse order.
4. Adjust tension of bottom belt first then top belt. Replace covers.

TIMING BELT TENSION

1. Remove belt covers and measure length of spring, Fig. 10.1. If measurement is not 4.38", adjustment is necessary.
2. Tighten central mower spindle housing bolts.
3. Loosen outboard spindle housing nuts, No. 2, Fig. 10.3, one turn only.
4. Loosen nuts, Fig. 10.1, completely which will allow springs, to move spindles outboard to tension belts.

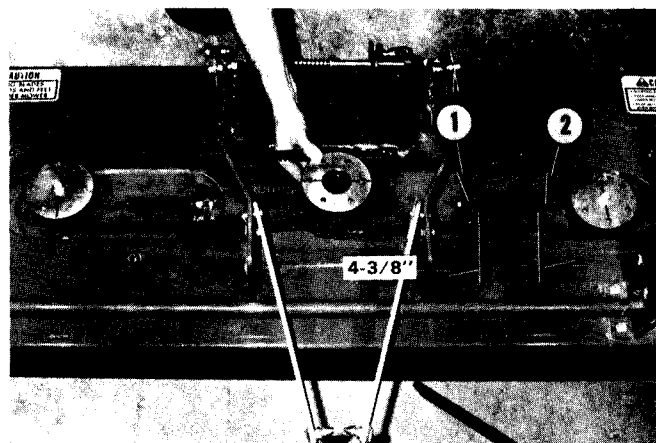

FIG. 10.1--REPLACING BELTS AND TIMING BLADES (48" SHOWN)

1. Adjusting Nut
2. Belt Tensioning Bolt

5. Tap spindle housing, Fig. 10.1, under mower base with a hammer to overcome any friction at mounting bolts.
6. Again check length of spring. If measurement is less than 4.38" remove washer. If measurement is more than 4.38" add washers between spring and anchor bracket until spring length is correct.
7. Tighten nuts, until there is 1/16" clearance between nut. No. 2, and anchor bracket.
8. Tighten spindle housing bolts, Fig. 10.3 to 30-35 ft.-lbs. torque. Reinstall belt covers.

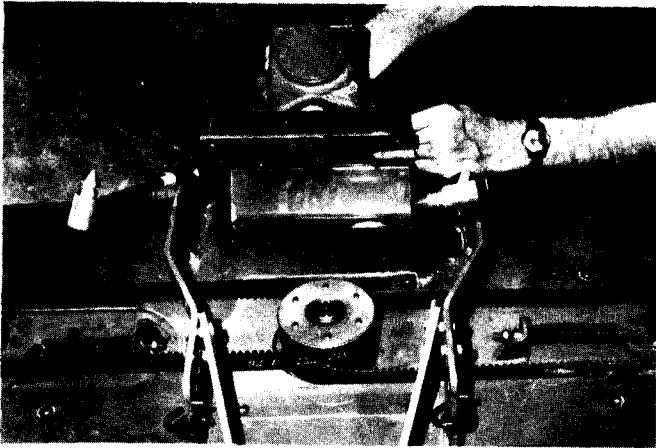

FIG. 2--TOP SIDE OF MOWER WITH SHIELDS AND GEAR BOX REMOVED

REPLACING BLADES

To keep blade from turning while loosening bolt, place a 2"x4" or similar block between blade and deflector under mower. Note order components are taken off so they can be replaced same way. Blades are attached to spindle by means of blade adaptor, two shear pins and a bolt with a belleville spring washer and lockwasher.

When sharpening blades on a grinder, take care not to overheat or metal will lose its temper and become soft. Grind each blade edge equally so that blade balance will be maintained. Replace blade and attaching parts in same order as removed. Tighten nut to 45 ft.-lbs. torque.

NOTE: Mower blades must be properly timed. The two outboard blades must be in line (parallel to each other) and center blade at 90 degree (perpendicular to outboard blades.)

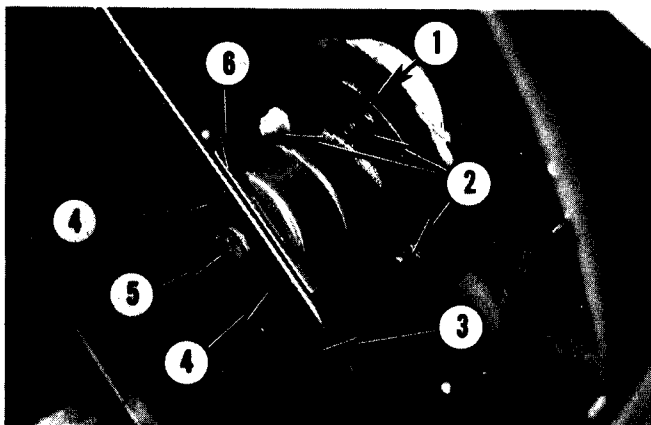

FIG. 10.3--BLADE SPINDLE DETAIL

1. Spindle Housing
2. Spindle Housing Retaining Bolts
3. Mower Blade

4. Shear Pins
5. Blade Retaining Bolt
6. Adapter

TIMING BLADES:

For blade replacement, timing does not have to be done via the belts. The spindle shaft hole in the blade provides various attaching positions.

1. Place a mark across all pulleys in line with cutting blade.
2. Position marks on outer pulleys lengthwise with mower and center pulley mark crosswise.
3. Install belts and slide center pulley on shaft.
4. Adjust nut on belt tension bolt until length of spring is 4-3/8", Fig. 10.1.
5. Tighten bolts holding spindle assembly in mower deck and complete reassembly.

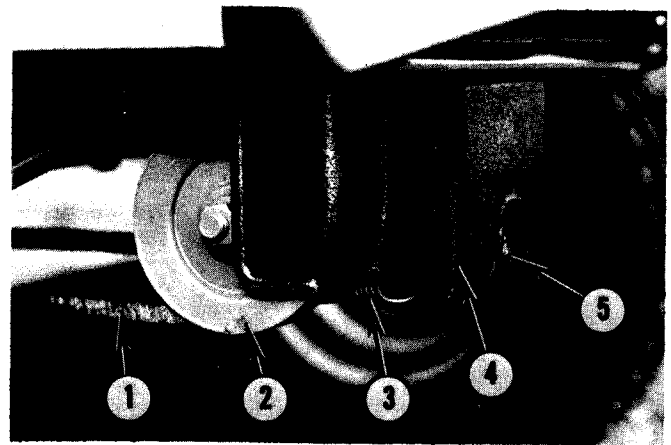

FIG. 10.4--MOWER "MULE DRIVE"

1. Mower Drive Belt
2. Right-Hand Pulley (Mule Drive Unit)
3. Tension Spring
4. Mule Drive Cover
5. Adjusting Bolt

DRIVE BELT REPLACEMENT (42" & 48" MOWERS ONLY)

1. Remove mule drive cover by removing two bolts, see Fig. 10.4.
2. Rotate adjusting bolt, No. 6, Fig. 49, counter-clockwise to relieve belt tension.
3. Push up on right-hand mule drive pulley, No. 5, Fig. 10.5, and remove belt, No. 2, from pulley.
4. Remove belt from left-hand mule drive pulley and then mower pulley.
5. Remove mule drive by removing two hair pins.
6. Install new belt, reinstall mule drive, adjust belt tension and replace mule drive cover.

DRIVE BELT TENSION(42" & 48")

1. Make sure mower is level before attempting to adjust belt tension.
2. With mower in lowered position, turn adjusting bolt, No. 6, Fig. 10.5, clockwise to adjust belt tension. When belt, No. 2, is properly tensioned, pulleys, Nos. 5 and 7, should be approximately same height from ground.
3. Place mower gauge wheels in full up position.
4. Adjust length of front lift links until the attaching points line up with the holes in front anchor plate.

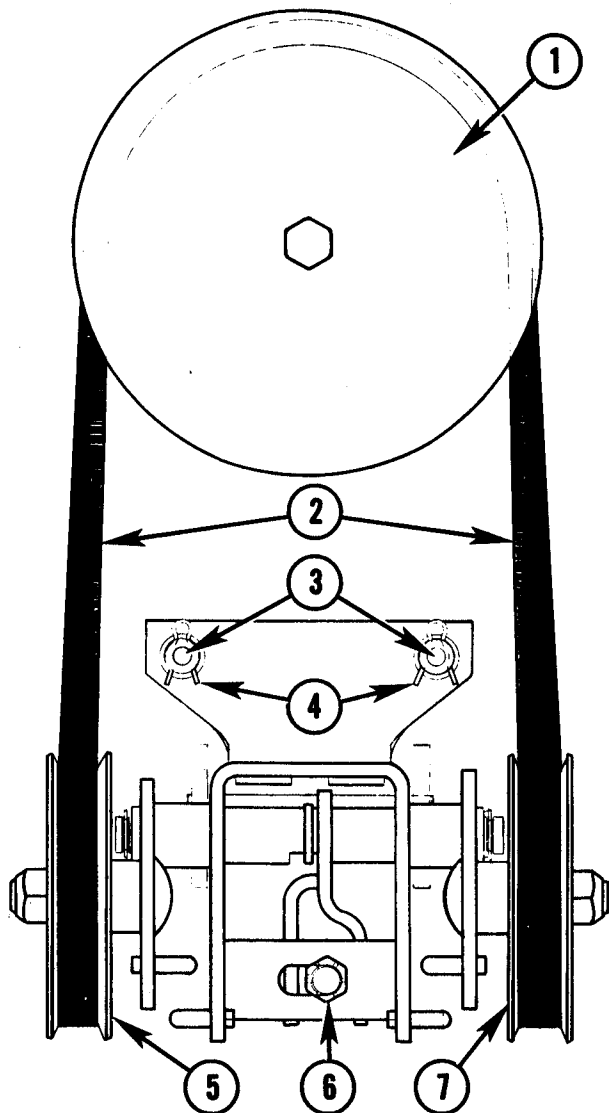

FIG. 10.5--DRIVE BELT ARRANGEMENT (FRONT)

1. Mower Drive Clutch Pulley
2. Mower Drive Belt
3. Mule Drive Mounting Pins
4. Mule Drive Retaining Clips
5. Right-Hand Pulley
6. Adjusting Bolt
7. Left-Hand Pulley

5. Remove mule drive cover by removing 2 bolts, see Fig. 10.4.
6. Remove mule drive unit by removing 2 spring clips, see Fig. 10.5.
7. Place mower drive belt over implement drive clutch pulley, see Fig. 10.5.
8. Reinstall mule drive.
9. Rotate bolt, No. 6, Fig. 10.5, counterclockwise and install belt, No. 2, Fig. 10.5, under left pulley, No. 7, Fig. 10.5, then place belt around mower clutch pulley, No. 5, Fig. 10.6.
10. Raise spring loaded pulley, No. 5, Fig. 10.5, and install belt under it as shown.
11. Rotate bolt, No. 6, Fig. 10.5, clockwise until both mule drive pulleys are the same height.
12. Reinstall mule drive cover.
13. If mower is not level refer to "Levelling" section on page 10.8.

SPINDLE REPAIRS

The mower has three similar spindles and blades. The outer spindles are connected to center spindle with a notched timing belt.

The spindles are the same except the center one has a longer shaft and double pulley.

1. Remove mower from Tractor.
2. Remove mower belt covers as necessary and remove "V" -belt pulley from center spindle if center spindle is to be serviced.
3. Tighten mower belt tensioner nuts as necessary to relieve belt tension on spindle pulleys, remove pulleys as necessary and then turn mower over and remove blades as necessary. Follow same procedure for 54" mowers except that a gearbox and mounting bracket assembly instead of a "V" -belt pulley will have to be removed.

CAUTION: Wrap a cloth around blade to prevent injury.

4. Remove bolts securing spindle assembly to mower and remove spindle.
5. Remove retaining ring from housing and bump shaft and bearing out. Fig. 10.8
6. Inspect bearings and seals, replace as required.
7. Install roller bearing and seal into housing until seal is flush with outside of housing. Fig. 10.9.

8. Reinstall shaft into housing and secure with retaining ring.

9. Reinstall spindle assembly in mower deck but do not tighten bolts unless center spindle was serviced.

10. Reinstall blades and pulleys and then refer to "Replacing Belts and/or Blades and Timing Blades".

NOTE: When reinstalling gearbox and mounting bracket assembly, extreme care should be taken to insure that the splined shaft of the gearbox is a free sliding fit in the center pulley. Mis-alignment will cause deterioration of pulley splines.

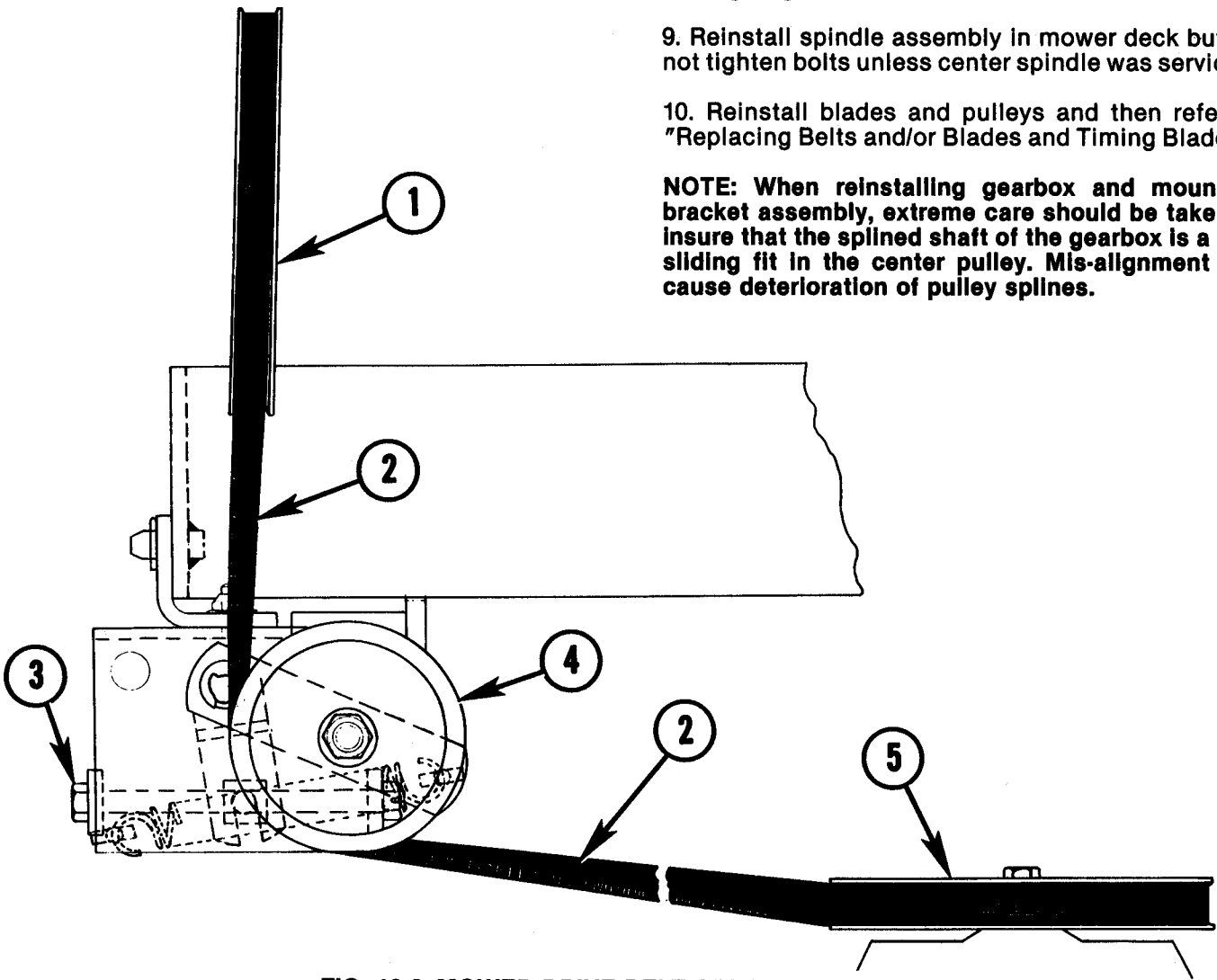

FIG. 10.6--MOWER DRIVE BELT ARRANGEMENT

- 1. Mower Drive Clutch Pulley
- 2. Mower Drive Belt
- 3. Adjusting Bolt

- 4. Mule Drive Pulleys
- 5. Mower Driven Pulley



FIG. 10.7--BEARING AND SEAL INSTALLED

- 1. Seal
- 2. Bearing

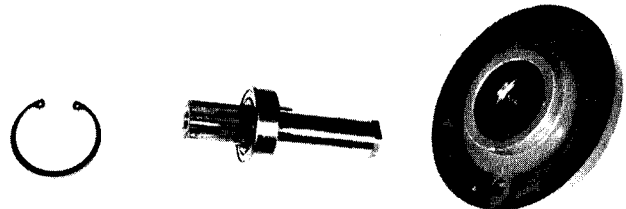

FIG. 10.8--SHAFT AND BEARING REMOVED

GEARBOX REPAIRS - 54" MOWERS

1. Remove mower from Tractor.
2. Remove gearbox from mower, Fig. 10.6.
3. Remove cover and clean grease from inside of case.
4. Slide both retaining rings together on input shaft.
5. Remove plate and shims from case at end of input shaft.
6. Bump shaft through bearings and gear through opening where plate was removed until bearing can be removed.
7. Remove bearing and lift shaft out of case through top opening.

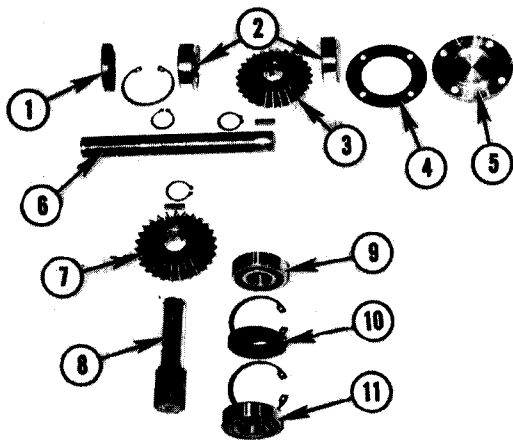

FIG. 10.9--GEARBOX COMPONENTS

- | | | |
|---------------|-----------------|-------------|
| 1. Seal | 6. Input Shaft | 11. Bearing |
| 2. Bearings | 7. Output Gear | |
| 3. Input Gear | 8. Output Shaft | |
| 4. Shim | 9. Bearing | |
| 5. Plate | 10. Seal | |

8. Remove seal, retaining ring and bearing from case.
9. Remove gear and retaining rings from input shaft.
10. Remove retaining ring and gear from output shaft.
11. Bump output shaft from bearings and out of case.
12. Remove bearings, retaining rings and seal from case.
13. Inspect all parts for wear or damage, replace as required. Refer to Fig. 10.9, for identification and sequence of parts.
14. Install retaining ring in groove in lower side of gearbox.
15. Install seal with lip of seal toward inside of gearbox and install another retaining ring, Fig. 10.10.

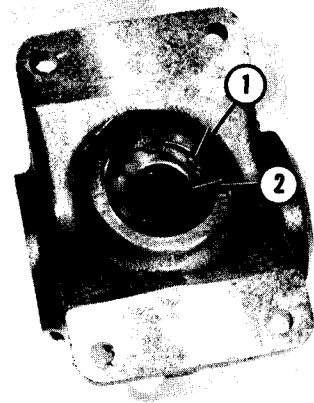

FIG. 10.10--OUTPUT SHAFT SEAL AND RETAINING RINGS INSTALLED

1. Retaining Ring
2. Seal

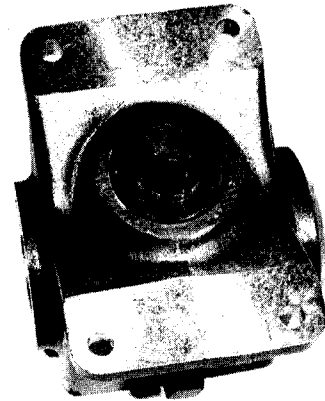

FIG. 10.11--OUTPUT SHAFT AND BEARING INSTALLED IN GEARBOX

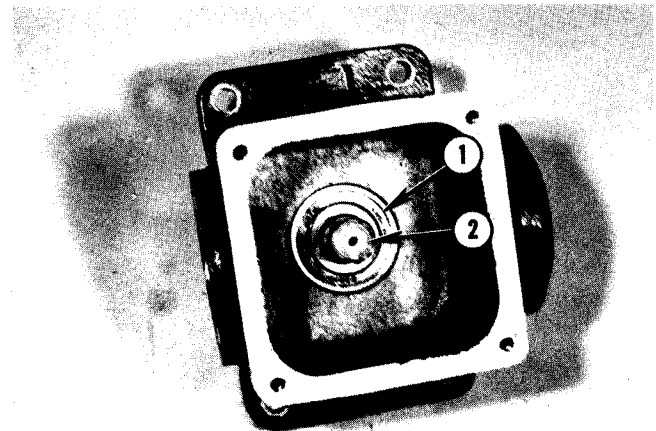

FIG. 10.12--OUTPUT SHAFT BEARING INSTALLED

1. Bearing
2. Output Shaft

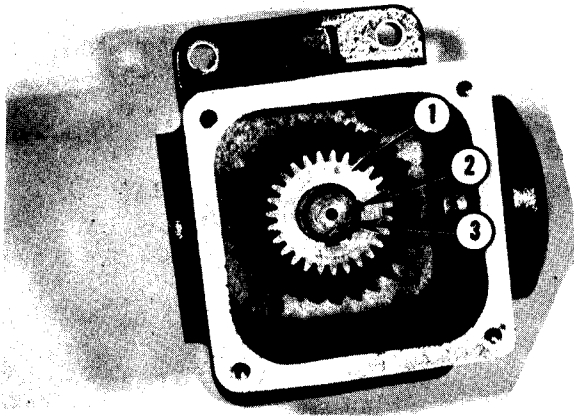

FIG. 10.13--OUTPUT GEAR INSTALLED

- 1. Gear
- 2. Retaining Ring
- 3. Output Shaft

16. Install one bearing on output shaft and install into gearbox against retaining ring, Fig. 10.11.

17. Install another bearing over other end of output shaft and against retaining ring, Fig. 10.12.

18. Install output gear with key and secure with retaining ring, Fig. 10.13.

19. Install retaining rings and one bearing on input shaft, Fig. 10.14.

20. Insert input shaft into gearbox and through gear with key. Fig. 10.15.

21. Install bearing on other end of input shaft. Fig. 10.16.

22. Install plate with shims then check gears backlash. Backlash in gear should be .002"-.005". Add or remove shims to obtain correct gear backlash. Fig. 10.17.

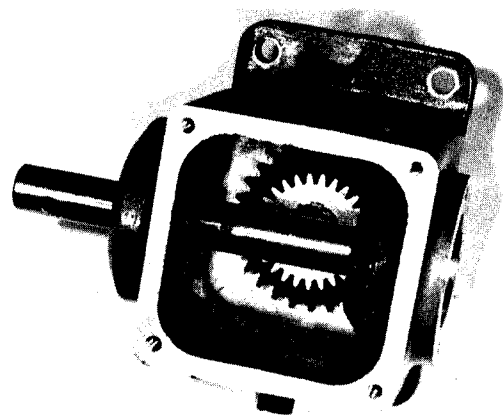

FIG. 10.15--INPUT SHAFT POSITIONED IN GEAR-BOX

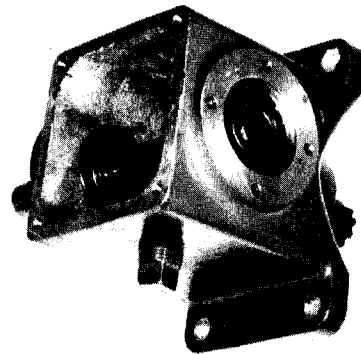

FIG. 10.16--BEARING INSTALLED OVER INPUT SHAFT

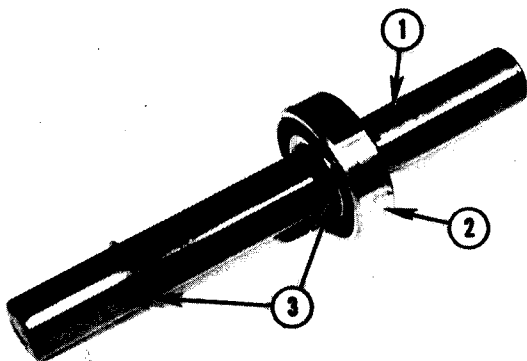

FIG. 10.14--INPUT SHAFT AND BEARING

- 1. Input Shaft
- 2. Bearing
- 3. Retaining Rings

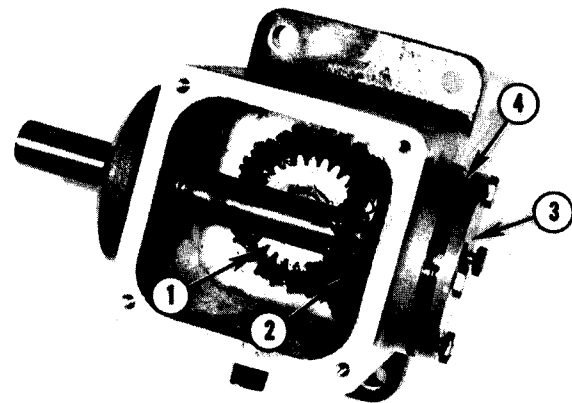

FIG. 10.17--ADJUSTING GEAR BACK-LASH

- 1. Output Gear
- 2. Input Gear
- 3. Plate
- 4. Shims

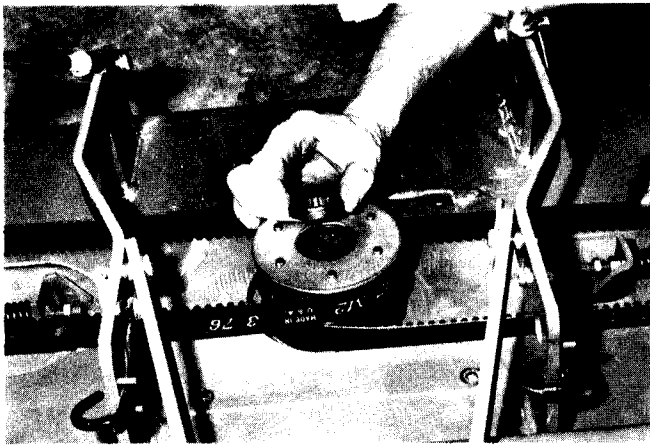

FIG. 10.18--INSTALLING SPACER BETWEEN GEAR-BOX AND PULLEY

23. Fill gearbox with molybdenum disulphide grease and install cover.

24. Install spacer, with chamfer up, on pulley as shown in Fig. 10.18 and install gearbox.

NOTE: When installing gearbox and mounting bracket assembly extreme care should be taken to insure that the splined shaft of the gearbox is a free sliding fit in the center pulley. Mis-alignment will cause deterioration of pulley splines.

ATTACHING 42" & 48" MOWERS TO TRACTOR

1. Slide mower under Tractor or using mounting ramp accessory, drive Tractor over mower.

2. Start Tractor engine, lower lift arms and then shut off Tractor engine.

3. Attach rear lift arms to rear anchor plates as shown in Fig. 10.19

4. Attach hanger straps to mower as shown in Fig. 10.19

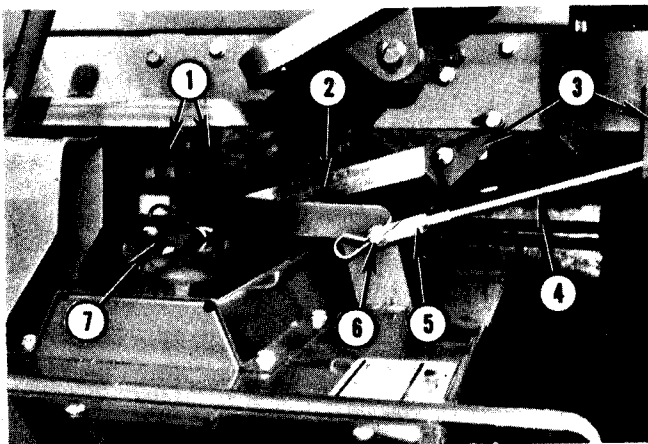

FIG. 10.19--ATTACHING MOWER

- | | |
|--------------------|----------------------|
| 1. Hanger Straps | 5. Yoke |
| 2. Rear Lift Link | 6. Bolt and Hair Pin |
| 3. Front Lift Link | 7. Retainer Spring |
| 4. Front Lift Link | |

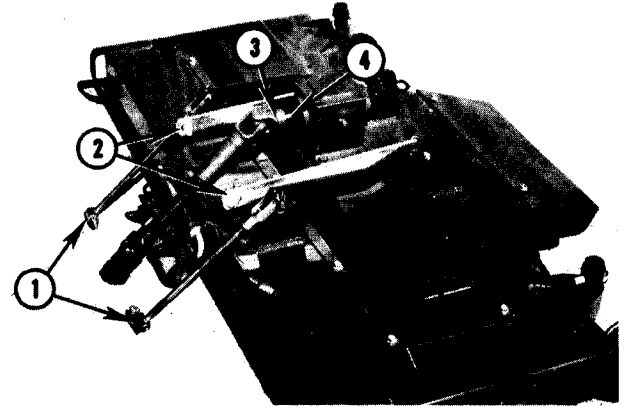

FIG. 10.20--LIFT LINK INSTALLATION

ATTACHING 54" MOWER TO TRACTOR

1. Slide mower under Tractor or using mounting ramp (accessory), drive Tractor over mower.

2. Start Tractor engine, lower hanger straps and then shut off engine.

3. Attach lift arms to anchor plates and hanger straps to mower. Secure in place with spring link retainers.

NOTE: Hanger straps are installed on left side of mower mounting brackets.

4. Place rear gauge wheels in full up position.

5. Place a 2x4 edgewise under the front edge to raise the front of the mower approximately 1/4 to 1/2 inch above the rear of mower.

6. Attach yoke end of front lift links to mower and then rotate lift link until the correct length fits snugly into front anchor plate.

7. Install PTO drive shaft on Tractor and secure with sliding lock.

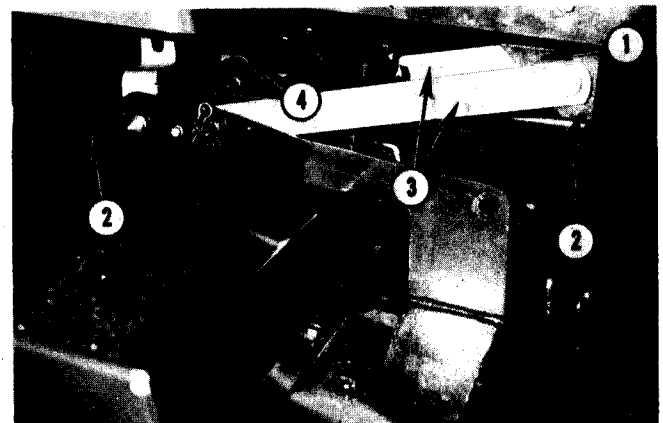

FIG. 10.21--MOWER INSTALLATION

- | | |
|-----------------|------------------|
| 1. Anchor Plate | 3. Lift Arms |
| 2. Link Springs | 4. Hanger Straps |

LEVELLING - MID MOUNT MOWERS

Tractor must be on level surface with tires properly inflated.

1. Place rear gauge wheels in full up position.
2. Place a two inch block under the front edge when required to raise the front of the mower approximately 1/4 to 1/2 inch above the rear of mower.

3. Allow mower to rest on gauge wheels.

4. Adjust front lift links so that they will snugly fit in to front anchor plates.

NOTE: Mower should be level or sloping up slightly at the front when on a flat surface when resting on gauge wheels in the full up position.

Free Manuals Download Website

<http://myh66.com>

<http://usermanuals.us>

<http://www.somanuals.com>

<http://www.4manuals.cc>

<http://www.manual-lib.com>

<http://www.404manual.com>

<http://www.luxmanual.com>

<http://aubethermostatmanual.com>

Golf course search by state

<http://golfingnear.com>

Email search by domain

<http://emailbydomain.com>

Auto manuals search

<http://auto.somanuals.com>

TV manuals search

<http://tv.somanuals.com>