

# Operator's Manual and Mower Assembly Instructions

for

# SNAPPER®

Model  
1600  
1600A

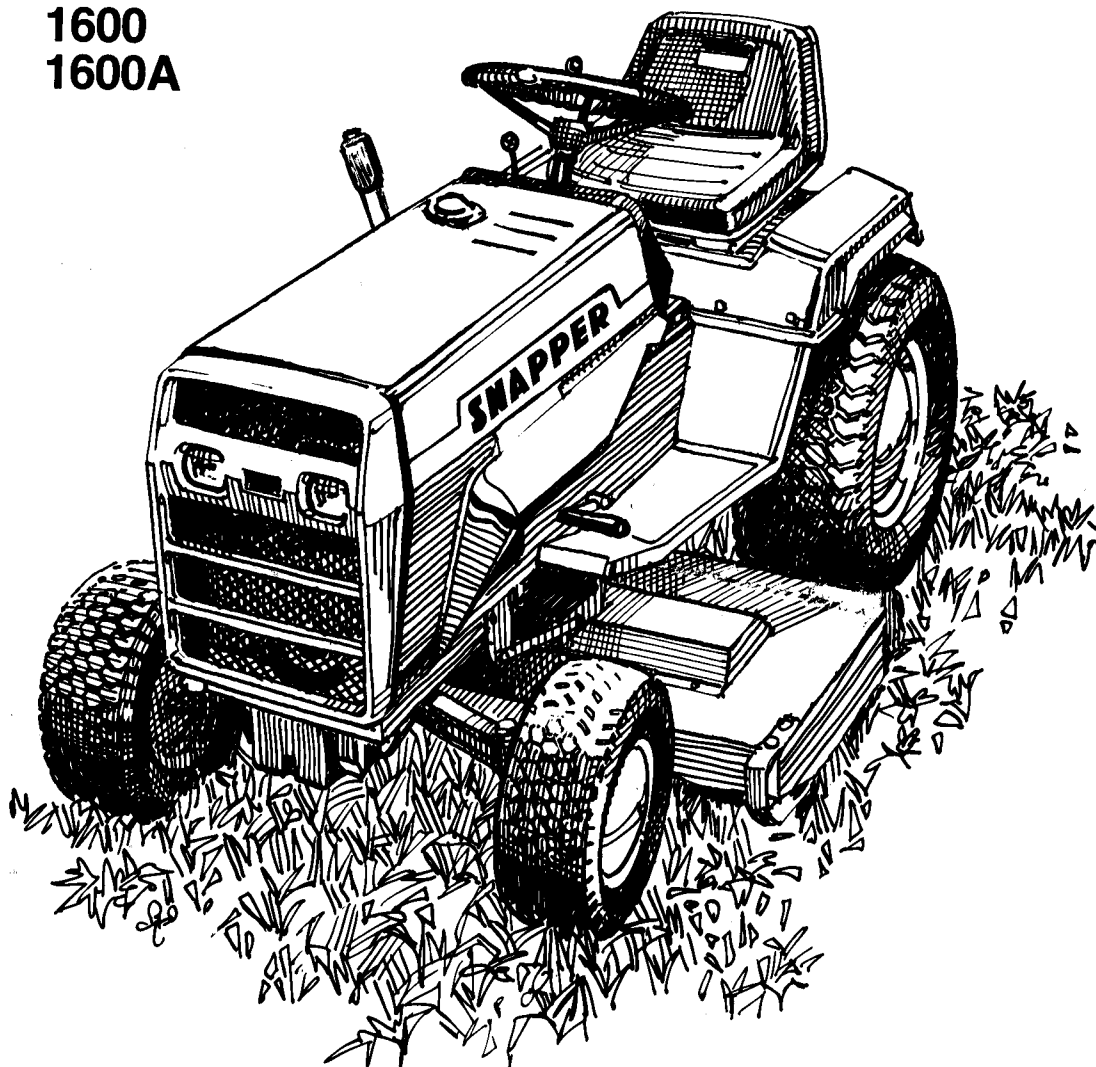

## GARDEN TRACTORS & MOWERS

McDonough Power Equipment, McDonough,  
Georgia 30253. A Fuqua Industry.



MANUAL 1-3015



## SAFETY PRECAUTIONS



Read this Manual carefully before operating machine. Give special attention to all safety suggestions. They are included for your protection.

- Know the controls and how to stop quickly. **READ THE OPERATOR'S MANUAL.**
- Do not allow children to operate the vehicle. Do not allow adults to operate it without proper instruction.
- Do not carry passengers. Keep children and pets a safe distance away.
- Wear substantial shoes and long pants while using Mower.
- Clear work area of objects which might be picked up and thrown.
- Disengage power to mower blades, depress clutch-brake pedal and shift into neutral before attempting to start engine.
- Disengage power to mower blades, shut off engine and remove key before leaving operator's seat.
- Disengage power to mower blades and shut off engine before making any repairs or adjustments.
- Disengage power to mower blades when transporting or not in use.
- Take all possible precautions when leaving the vehicle unattended, such as disengaging power, lowering mower blades, shifting into neutral, setting parking brake, shutting off engine and removing key.
- Set mower at highest cutting height when mowing in rough ground or in tall weeds.
- Do not stop or start suddenly when going uphill or downhill.
- Reduce speed on slopes and in sharp turns to prevent tipping or loss of control. Exercise extreme caution when changing direction on slopes.
- Stay alert for holes in terrain and other hidden hazards.
- Do not operate mower in wet grass.
- Use care when pulling loads.
- Use only approved drawbar hitch point.
- Limit loads to those you can safely control.
- Do not turn sharply. Use care when backing.
- Watch out for traffic when crossing or near roadways.
- This Tractor is not designed, nor intended for street or highway use.
- When operating mower blades, never direct discharge of material toward bystanders nor allow anyone near vehicle while in operation.
- Handle gasoline with care — it is highly flammable.
- Use approved gasoline container.
- Never remove cap of fuel tank or add gasoline while engine is running or hot. Never fill fuel tank indoors. Wipe up spilled gasoline.
- Open doors if engine is run in garage — exhaust fumes are dangerous.
- Keep unit in good operating condition, and keep safety devices in place.
- Keep all nuts, bolts and screws tight to be sure equipment is in safe working condition.
- Never store equipment with gasoline in tank inside a building where fumes may reach an open flame or spark. Allow engine to cool before storing in any enclosure.
- To reduce fire hazard, keep engine free of grass, leaves or excessive grease.
- Mower should be stopped and inspected for damage after striking a foreign object, and damage should be repaired before restarting and operating.

- Do not change engine governor settings or over-speed engine.

- When using unit, proceed as follows:

Mow only in daylight or in good artificial light.

Never make a cutting height adjustment while engine is running.

Shut engine off when unclogging mower.

Check blade mounting bolts for proper tightness at frequent intervals.

- With riding mowers mow slopes up and down. Moving across slopes could tip a rider over.

- Make sure tractor is equipped with rear PTO shield.

**PERSONAL INJURY MAY RESULT IF THESE PRECAUTIONS ARE NOT FOLLOWED.**



Look for this symbol to point out important safety precautions. It means – ATTENTION! BECOME ALERT! YOUR SAFETY IS INVOLVED.

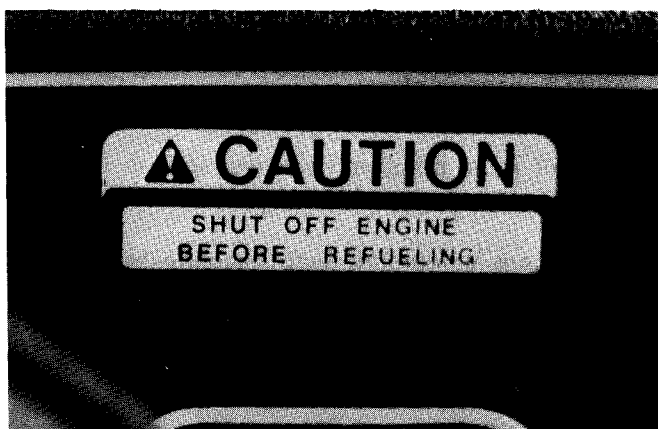
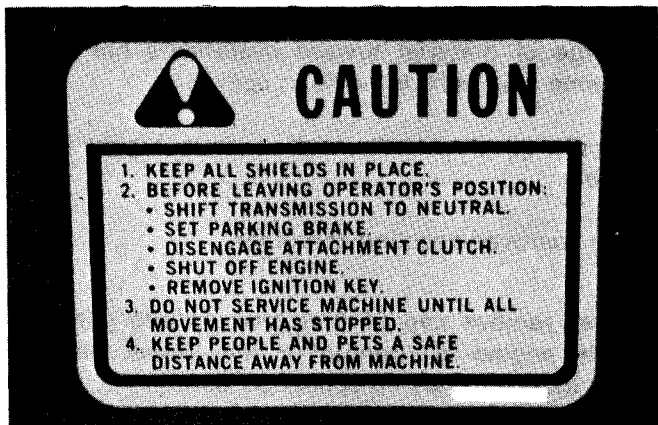

# INDEX

	PAGE		PAGE
INTRODUCTION .....	4	Breaker Points .....	19
IDENTIFICATION PLATES .....	5	Engine Cylinder Head Bolts .....	19
ASSEMBLY AND		Carburetor Adjustment .....	19
PRE-DELIVERY INSTRUCTIONS .....	7	Governor Adjustment .....	20
CONTROLS .....	9	Power Take-Off .....	21
Ammeter .....	9	Front Belt Adjustment .....	21
PTO Switch .....	9	Front Belt Replacement .....	21
Choke .....	9	Rear Belt Adjustment .....	21
Ignition Switch .....	9	Rear Belt Replacement .....	22
Throttle .....	9	Brake Adjustment .....	22
Hourmeter (Accessory) .....	9	Transaxle Belt Guide	
Gearshift Lever .....	9	Adjustment .....	22
Rear PTO Lever .....	10	Toe-In .....	23
Implement Lift Lever .....	10	Wiring .....	23
Clutch-Brake Pedal .....	10	Tractor Storage .....	23
Seat Adjustment .....	11	Removing From Storage .....	25
TRACTOR OPERATION .....	12	Trouble-Shooting .....	25
Pre-Starting Inspection .....	12	TRACTOR SPECIFICATIONS .....	26
Operating Tips .....	12	ROTARY MOWER .....	27
Starting Engine .....	12	Installation .....	27
Driving Tractor .....	14	Preparing Tractor .....	27
Stopping Tractor .....	14	Preparing Mower .....	27
Travel Speeds .....	14	Attaching .....	27
Moving By Hand .....	14	Operation .....	28
Attaching Implements .....	14	Detaching .....	30
PTO Shield Installation .....	15	Attaching and Detaching .....	30
LUBRICATION .....	16	Using Mounting Ramps .....	30
TRACTOR MAINTENANCE .....	18	Mower Adjustments .....	30
Battery .....	18	Levelling .....	30
Air Cleaner .....	18	Mower Drive Belt Tension .....	30
Tires and Wheels .....	18	Mower Drive Belt	
Fuel Filter .....	18	Replacement .....	31
Cooling System .....	18	Mower Belt Tension .....	31
SERVICING .....	19	Belt Replacement .....	31
Spark Plug .....	19	Replacing Blades .....	31
MANUFACTURER'S LIMITED WARRANTY .....		Mower Storage .....	31
		Removing Mower	
		From Storage .....	32
		MOWER SPECIFICATIONS .....	32
			INSIDE BACK COVER

## INTRODUCTION

The Snapper 1600 series tractor is equipped with a 16 horsepower, air-cooled, four-cycle engine and a four-speed manual shift transaxle with reverse.

PTO driven implements are controlled by an electric clutch, which is driven by engine front PTO shaft. Mounted implements are raised and lowered by a hydraulic lift. Rear PTO, which is standard on 1600A and optional on 1600 models, is controlled by a belt idler clutch.

Tractors are equipped with headlights, twin tail lights and electric starter. A variety of front, mid and rear mounted implements are usable with machine.

This Manual contains two sections regarding care of Tractor. "Maintenance" Section is concerned with usual servicing procedures, requiring average mechanical ability. "Servicing" Section discusses more complex procedures, requiring above average mechanical ability and tools. Although all service must be performed in a competent manner, it is recommended that procedures discussed in "Servicing" Section be performed by able mechanics, such as those available at Snapper Dealers.

All directions, left or right, are when seated on Tractor seat. **READ THIS MANUAL CAREFULLY BEFORE OPERATING TRACTOR AND ROTARY MOWER.** Give special attention to paragraph entitled "Pre-Starting Inspection".

The rotary lawn mowers are a new concept with three in line overlapping blades synchronized through heavy-duty timing belts. Input drive to mower includes a belt drive, from electric clutch pulley and idler pulleys on the Tractor, to input pulley on central mower spindle.

## IDENTIFICATION PLATES

Tractor chassis, engine and Mower base each have identification plates. Record numbers on these plates in spaces provided and refer to them when requesting parts. Note that engine has model, serial and specification numbers, while other plates have only model and serial numbers.

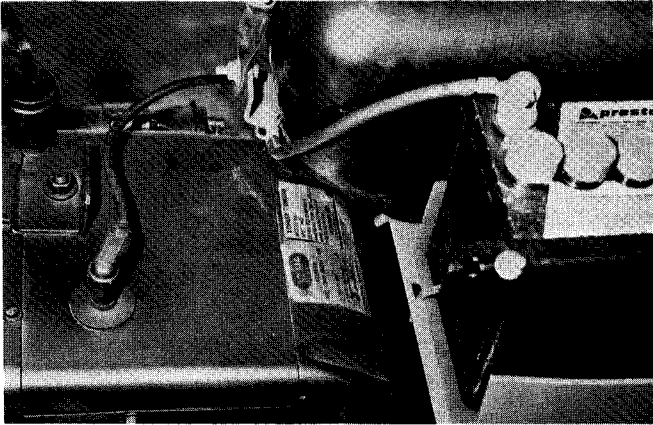

**ENGINE SERIAL NO.**

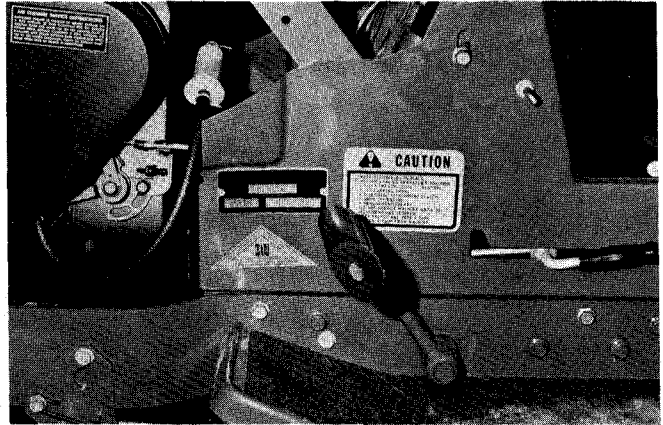

**CHASSIS SERIAL NO.**

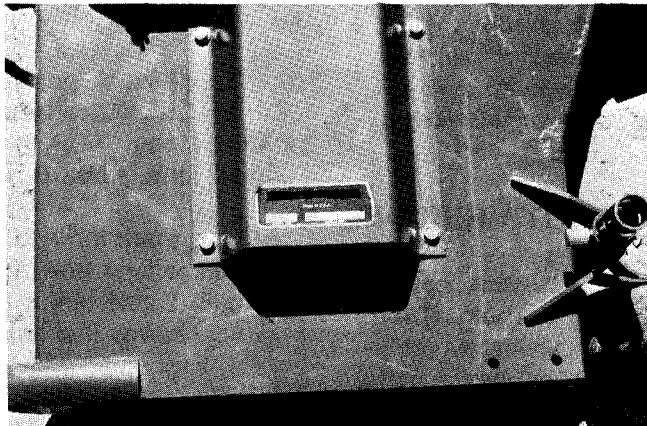

**MOWER SERIAL NO.**

## FUEL

Refill tank after using Tractor, except when storing machine. If a fuel tank is partially filled for an extended period of time, condensation may occur. Fill tank with clean, fresh, unleaded (preferred) or regular gasoline. **NEVER USE A MIXTURE OF GASOLINE AND MOTOR OIL.**

If dirt, water or other contaminants are present in fuel, drain fuel tank and line. Blow out line, clean tank and refill.



**CAUTION: Fill fuel tank outdoors and never fill while engine is running or hot.**

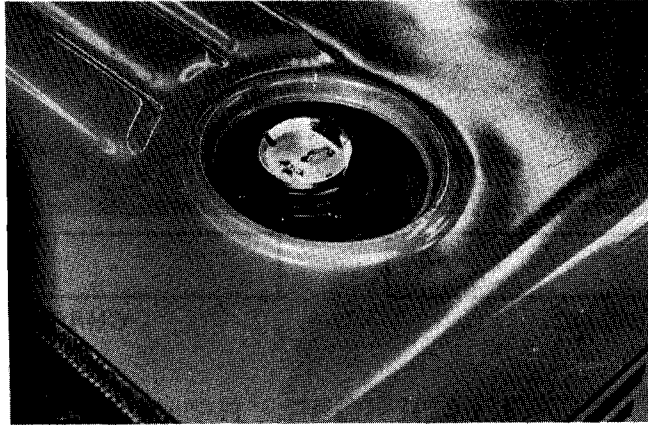

# ASSEMBLY AND PRE-DELIVERY INSTRUCTIONS

These Instructions have been prepared as a guide to assist in pre-delivery and inspection, as outlined on New Tractor Pre-Delivery Inspection Check List (see back of Manual). Each item on the Check List is explained in these Instructions.

To ensure new tractor performance and complete customer satisfaction, carry out each inspection operation completely and accurately.

## ASSEMBLY

### STEERING WHEEL

The Garden Tractor is shipped completely assembled, except for steering wheel and operator's seat. With front wheel straight forward, position steering wheel on shaft, install washer and nut and tighten to 35-45 ft.-lbs. Insert center cover into groove in top of steering wheel with tang in recess in groove.

### MOWER

See Page 27 for mower installation.

## PRE-DELIVERY

### ENGINE OIL LEVEL

Engine crankcase is filled at the factory to proper oil level. If oil level is low, fill to full mark on dipstick, Page 16.

### ALL OIL DRAIN PLUGS

Check oil drain plugs for tightness.

### FUEL LINE CONNECTIONS

Fill fuel tank and check for leaks at all connections.

### SERVICE AIR FILTER

Check that air cleaner element is properly installed and retainer is tight.

### ELECTRICAL CONNECTIONS

Check wiring connections for tightness.

### CHOKE CONTROL

Be sure choke control operates freely and butterfly in carburetor is completely opening and closing.

### ACTIVATE BATTERY



**CAUTION: Electrolyte contains sulphuric acid. Keep acid out of eyes, off skin and clothes.**

Tractor is shipped with a dry charge battery. Following procedure is recommended for activation of battery:

1. Remove battery from Tractor.
2. Remove caps and be sure vent holes are open.
3. Battery and electrolyte temperature should be at least 70° F.
4. Fill each cell with electrolyte to level of indicator, or 3/16 inch above top of separators.
5. Permit battery to stand for 30 minutes.
6. Check electrolyte level and add as necessary. **DO NOT OVERFILL.**
7. Replace filler caps and charge battery at a rate not exceeding 4 amps, until specific gravity of each cell reaches 1.250.
8. Install battery.

### ALTERNATOR CHARGING RATE

Observe alternator charging rate by visual observation of ammeter.

### ENGINE RPM (IDLE)

Engine idle speed should be 2100 to 2300 rpm. See Page 20.

### ENGINE RPM (FULL THROTTLE)

Full throttle engine rpm should be 3500 to 3650 rpm, with no load. See Page 20.

### CARBURETOR ADJUSTMENT

Carburetor is adjusted by engine manufacturer and should not be changed unless engine does not function satisfactorily.

Idling air adjustment should be made at same time as high speed adjustment as each affects the other. See page 20.

### GOVERNOR PERFORMANCE

Governor action should be responsive without surging. Surging is the result of incorrect adjustment or binding of governor linkage.



## **TRANSAXLE OIL LEVEL**

Remove oil level plug from front of transaxle housing. If oil does not run out, add SAE 90 transmission oil through filler plug, located below seat, until oil runs out oil level hole.

## **LUBRICATE FITTINGS**

Lubricate grease fittings with a good grade of lithium base, general purpose grease. See Page 16.

## **CLUTCH BRAKE LINKAGE**

Check adjustment. See Page 22.

## **TIGHTEN ALL CHASSIS BOLTS AND SCREWS**

Check chassis bolts carefully. Some are in aluminum housings and if overtightened threads may be easily damaged.

## **WHEEL BOLTS (REAR)**

Check rear wheel bolts for tightness. See Page 18.

## **TIRE PRESSURE**

Tractors are shipped with tires inflated from 25 to 30 psi. Check tires carefully and bring pressures to amounts listed on Page 18.

## **ENGINE CYLINDER HEAD BOLTS**

Check cylinder head bolts, in order shown, Fig. 22, to 300 in.-lbs. (30 ft.-lbs.) torque.

## **DRIVE TEST**

Drive Tractor, observing ammeter, controls and clutch-brake operation. Check operation of all safety switches in brake, seat and PTO controls.

## **IS OPERATOR'S MANUAL AND ASSEMBLY INSTRUCTIONS WITH TRACTOR?**

Make sure Operator's Manual and Assembly Instructions are with Tractor and explain following to owner:

- Controls
- Wheel Tread Adjustments
- Operating Procedures
- Lubrication
- Air Filter Service
- Tire and Battery Care
- Storage
- Operator's Manual
- Safety and Caution Notes and Procedures.

# CONTROLS

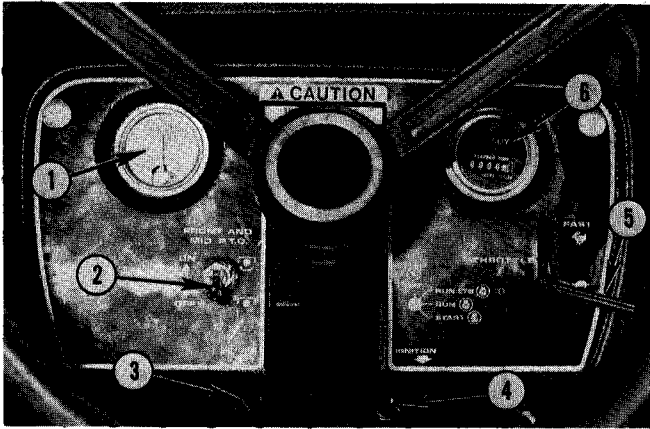

Fig. 1 — Instrument Panel

- |               |                          |
|---------------|--------------------------|
| 1. Ammeter    | 4. Ignition Switch       |
| 2. PTO Switch | 5. Throttle Lever        |
| 3. Choke      | 6. Hourmeter (Accessory) |

## AMMETER — NO. 1, FIG. 1

Ammeter is on left side of instrument panel. Normally needle will be on right (+) side of dial when engine is running, indicating alternator's rate of charge. If ammeter indicates a discharge (with needle on (-) side of dial) for any length of time, check wiring, battery and circuit breaker for shorts or other malfunctions.

## PTO SWITCH (IMPLEMENT DRIVE) — NO. 2, FIG. 1

PTO switch is above choke control. Pull out and raise switch lever over safety cap to activate implement drive clutch and flipping down switch (disengaged) turns it off. Clutch is located on PTO shaft on front of engine, Fig. 25. Ignition switch must be turned on to activate PTO switch. PTO switch must be disengaged (down) to start engine. Verify that engine starter will not engage with PTO switch in engaged position.

## CHOKE — NO. 3, FIG. 1

Pull knob out when starting a cold engine. As engine warms up and begins to run smoothly, push knob in.

## IGNITION SWITCH — NO. 4, FIG. 1

Ignition switch is key operated and is on right lower portion of instrument panel. It has four positions; off, run with lights, run and start. Turning

key to start cranks starter motor. When key is released, it returns to run position. Turning key one notch to left of "Run" turns on lights. Turning key one more notch to left shuts off engine.

## SEAT SWITCH (DEAD MAN CONTROL)

A switch in ignition cut off circuit is located under seat, Fig. 7. Operator must be seated on Tractor to start or run engine.

## THROTTLE — NO. 5, FIG. 1

Pushing lever up increases engine speed. When lever is all the way down, engine is at idling speed.

## HOURLMETER — NO. 6, FIG. 1 (ACCESSORY)

Hourmeter indicates accumulated hours of engine operation.

## GEARSHIFT LEVER — NO. 1, FIG. 2

*IMPORTANT: Never attempt to shift gears when Tractor is moving.*

The gearshift lever is located just in front of seat. Forward and reverse gear locations are indicated on console label, No. 2, in front of lever.

*IMPORTANT: If gears do not engage, allow clutch pedal to raise slightly, then depress and shift into gear.*

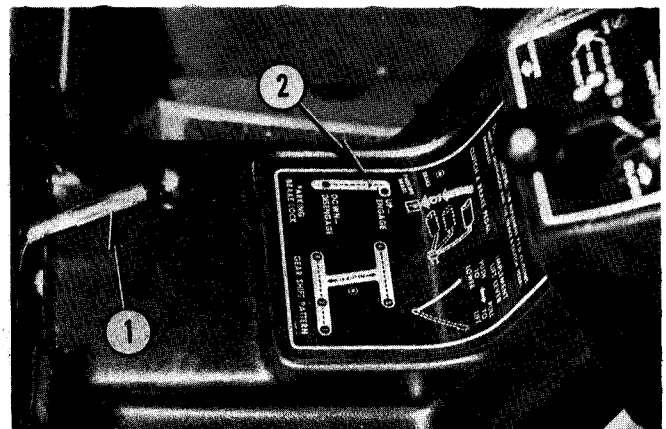
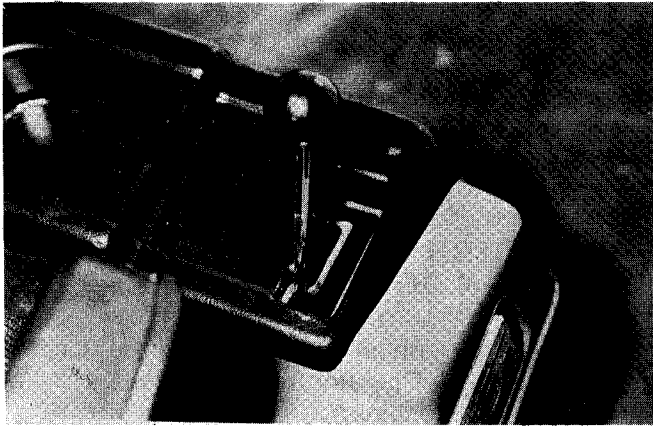

Fig. 2 — Gearshift Lever

- |                    |                  |
|--------------------|------------------|
| 1. Gearshift Lever | 2. Console Label |
|--------------------|------------------|



**Fig. 3 — Rear PTO Control Lever**

### REAR PTO CONTROL LEVER — FIG. 3

Moving lever to right engages rear PTO and moving lever to left disengages PTO. Control lever must be in "Off" position to start engine. Verify that engine starter will not engage with rear PTO engaged.

### IMPLEMENT LIFT LEVER — NO. 1, FIG. 4

Implement lift lever is located on right side of Tractor. To raise an implement, depress thumb button and pull back on lever. To lower an implement, depress button and push lever forward. Lever allows four positions for height or depth of mounted implements. Releasing button locks implement in position.

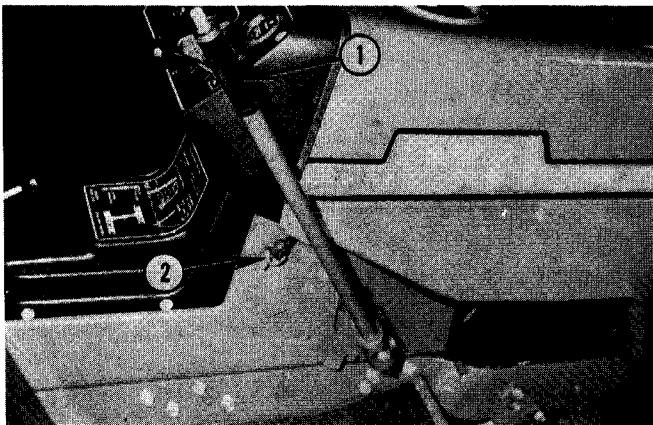

**Fig. 4 — Implement Lift Lever**

1. Lift Lever      2. Hood Latch

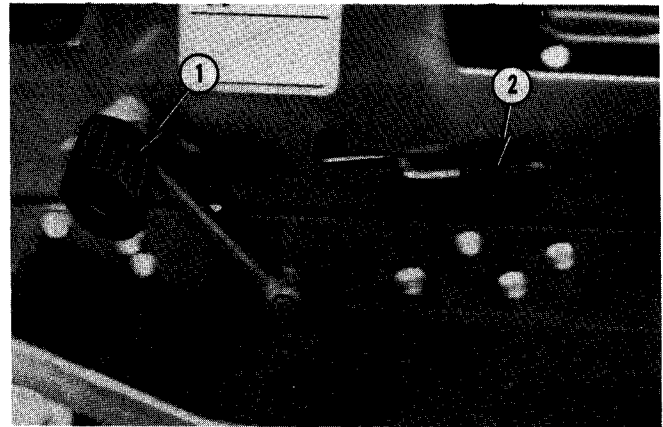

**Fig. 5 — Clutch-Brake Pedal**

1. Clutch-Brake Pedal      2. Parking Brake Lever

### CLUTCH-BRAKE PEDAL — NO. 1, FIG. 5

When pedal is all the way up clutch is engaged. Pushing pedal part way down disengages clutch. Pushing pedal all the way down engages brake. To lock brake in "Park" position, hold pedal completely down and move parking brake lever, No. 2, up into slot (see Fig. 6). Pedal must be depressed to start engine and to shift gears.



**CAUTION: Verify that engine starter will not engage without depressing clutch brake.**

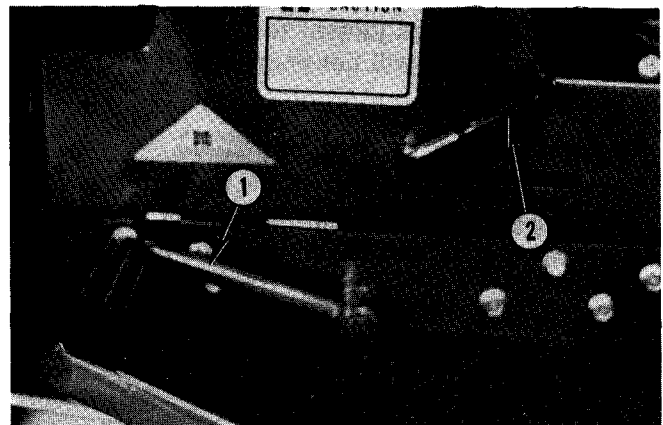
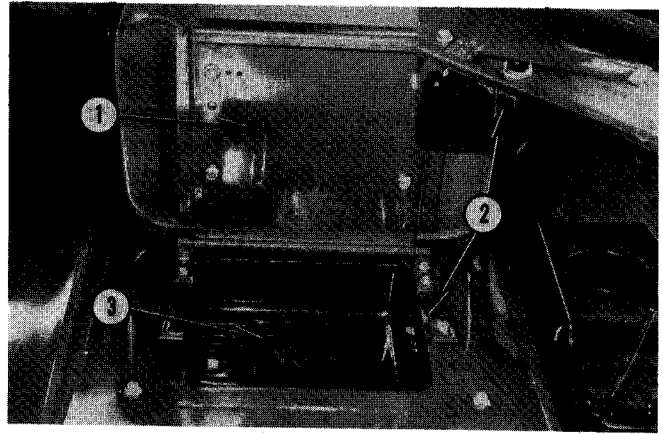

**Fig. 6 — Clutch-Brake Pedal Locked**

1. Clutch-Brake Pedal      2. Parking Brake Lever

## SEAT ADJUSTMENT

There are three sets of holes on underside of seat plate, Fig. 7, permitting seat to be moved forward or backward to match operator size.



**Fig. 7 — Seat**

- 1. Seat Plate**
- 2. Safety Switch**
- 3. Tool Box**

# TRACTOR OPERATION

Read these instructions carefully before operating Tractor! Become thoroughly familiar with all controls and their operating characteristics. TAKE TIME TO BE SAFE!

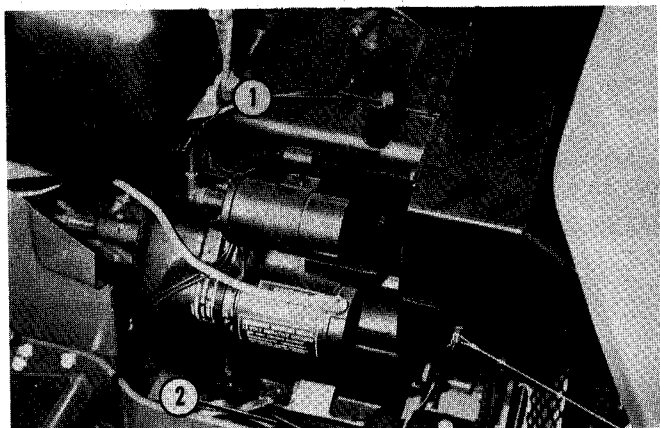

Fig. 8 — Engine Crankcase Lubrication

1. Dipstick and Fill Point
2. Drain Plug — Underneath Engine

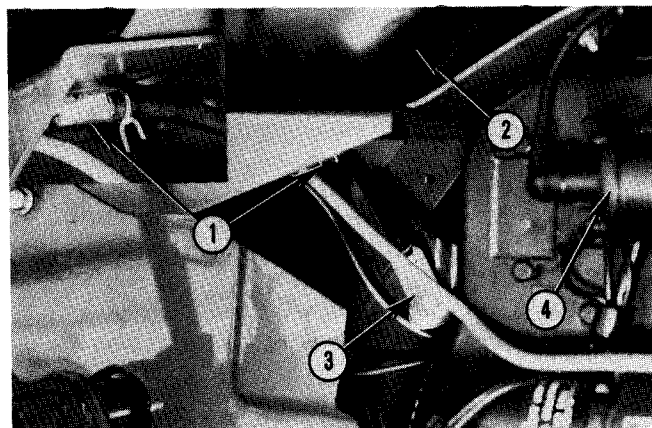

Fig. 9 — Fuel Shut-Off Location

1. Fuel Shut-Off Valve
2. Fuel Tank
3. Fuel In-Line Filter
4. Coil

## PRE-STARTING INSPECTION

**IMPORTANT:** Carefully check Tractor, giving special attention to lubrication, before starting engine! An inadequately filled crankcase can quickly damage an engine.

Check following:

1. Remove dipstick, No. 1, Fig. 8, wipe carefully with clean cloth, then replace in filler hole, pushing it all the way in. Remove and check oil level. If not to full mark, fill to this point. **DO NOT OVER-FILL.** Use only lubricants recommended in "Lubrication" Section. With proper oil level, dipstick will indicate excessive oil level when dipstick is removed after stopping engine. Wipe off and reinsert dipstick and remove again to check.

**NOTE:** After first five hours of operation with a new engine, drain and refill crankcase as recommended. See Page 16.

2. Check oil level of transmission rear axle, filling if needed.
3. Fill fuel tank with clean, fresh, unleaded (preferred) or regular grade gasoline.



**CAUTION:** Never smoke when filling fuel tank. Never fill tank near sparks or flame. If fuel is spilled on Tractor, wipe up and allow time to evaporate before attempting to start engine.

4. If there are traces of dirt, water or other contaminants in fuel, as visible through transparent

case containing in-line filter, No. 3, Fig. 9, close fuel shut-off valve, No. 1, and remove and replace in-line filter. Make certain valve is open at least two full turns before attempting to start engine.

## OPERATING TIPS



**CAUTION:** Never operate Tractor nor any power driven attachments with shields or guards removed.

Operate Tractor at 3/4 to full throttle for first five hours. It should be under full load (such as with Rotary Mower in operation) during entire break-in period.

Always maintain sufficient engine speed to prevent lugging. Required engine speed will vary with implement or load.

Maintain safe operating speeds at all times in relation to ground conditions.

When leaving Tractor seat, always turn off engine, make sure all controls are in "Neutral" or "Off" position, engage parking brake and remove key.

## STARTING ENGINE

### WARM WEATHER



**CAUTION:** Make sure all operating controls of Tractor and implement are in neutral or disengaged before attempting to start engine.

1. Depress clutch-brake pedal and disengage PTO switch and if equipped, PTO lever. Pedal, switch, seat and PTO lever are equipped with safety switches. If pedal is not depressed and PTO controls are not disengaged, starter motor should not operate. If operator is not on seat, ignition will be grounded and engine will not start or run.

2. Advance throttle approximately 1/4 and pull choke all the way out.

*NOTE: If engine is warm, it may not be necessary to use choke to start engine.*

3. Turn ignition key to start position. Release key when engine starts. If lights are needed, turn key to lights position after engine starts.

4. If engine is cold, allow it to warm up briefly before engaging transmission or implement drive.

5. Adjust choke for smooth operation, pushing in to off position when engine is warm. See IMPORTANT after "Cold Weather".

## COLD WEATHER



**CAUTION: Make sure all operating controls of Tractor and implement are in neutral or disengaged before attempting to start engine.**

Engine starting is possible in cold weather providing correct weight of oil is used (see "Lubrication" Section), battery is fully charged, and proper starting procedure is followed. Best procedure for starting at temperatures near or below freezing is as follows:

1. Pull choke all the way out into full choke position.

2. Move throttle lever downward into slow position.

3. Transmission must be in neutral position.

4. Move key switch into start position and hold until engine starts. As soon as it starts, release key and slowly push choke in part way.

*NOTE: In cold weather, starting motor may disengage prematurely. This is caused by engine firing once but failing to continue running. If this happens several times, engine will be flooded and it will be necessary to start as described in Step 5.*

5. Leave throttle in slow position, but push choke in all the way, then turn key to start position and slowly pull choke out to position which will cause engine to start and continue running. If engine falters after shifting gears, pull choke out part way until engine runs smoothly, then gradually push choke back in as engine warms.

See IMPORTANT section following these procedures.

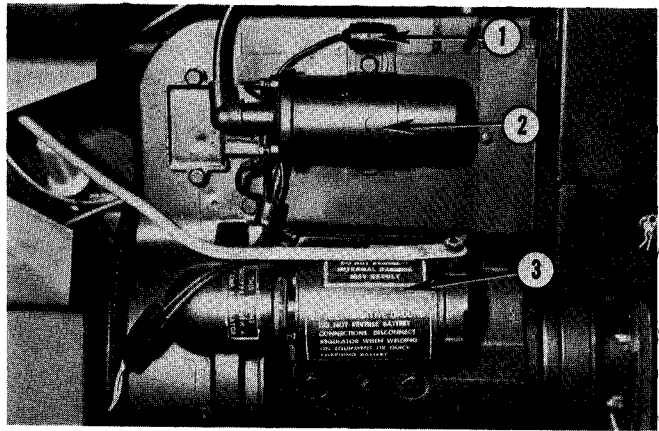

**Fig. 10 — Starter Motor Location**

1. Condenser      2. Coil      3. Starter

**IMPORTANT: READ FOLLOWING INFORMATION CAREFULLY. IT PERTAINS TO PROPER OPERATION AND PROTECTION OF ELECTRICAL SYSTEM!**

1. Never operate starter motor, Fig. 10, continuously for more than 30 seconds. Prolonged operation can damage starter motor. If engine does not start after a few seconds, release ignition key and allow a few moments for starter to cool before again attempting to start.

2. If battery loses its charge and requires jumping, make sure alternator is disconnected. To disconnect, pull connector, No. 2, Fig. 11, from rectifier-regulator, No. 3. Failure to do so can cause damage to alternator when battery is jumped. When using a booster battery, always connect cables positive (+) to positive, and negative (-) to negative, Fig. 12. Battery posts are marked. If battery requires charging, always remove from Tractor. Reconnect plug in rectifier-regulator after engine is started.

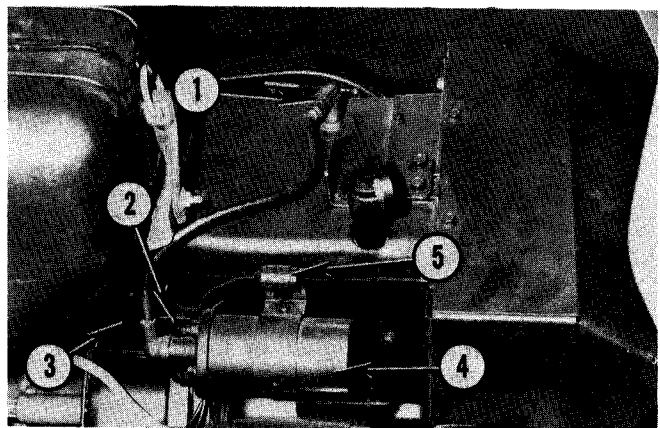

**Fig. 11 — Rectifier-Regulator**

1. Spark Plug      3. Rectifier-Regulator  
2. Connector      4. Coil  
5. Condenser

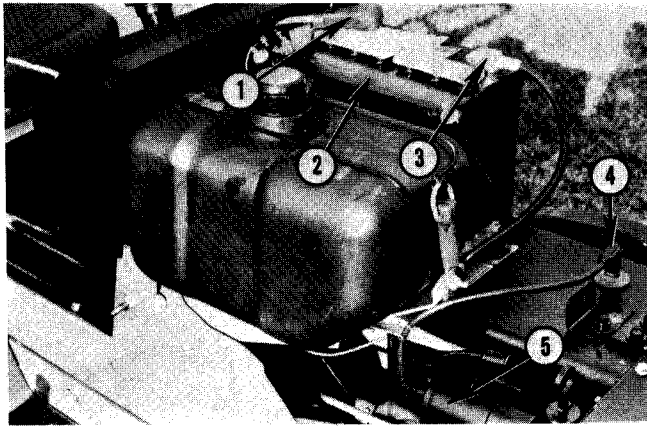

Fig. 12 — Battery

- |                      |                      |
|----------------------|----------------------|
| 1. Positive Post (+) | 3. Negative Post (-) |
| 2. Battery           | 4. Spark Plug        |
|                      | 5. Coil              |



**CAUTION:** Gases which emanate from a battery are explosive. Never smoke nor allow flame or sparks near a battery that is being charged.

3. Never operate Tractor with battery removed, unless connector from rectifier-regulator is unplugged.

4. If welding, using Tractor frame as a ground, always unplug connector to rectifier-regulator.

## DRIVING TRACTOR



**CAUTION:** Carbon monoxide is odorless, tasteless and deadly. Never operate Tractor engine in a closed building.

1. When engine is warm, set throttle at idle and depress pedal enough to release clutch.

2. Move parking brake lever to "disengage".

3. Shift into desired gear. If gears do not engage readily allow pedal to raise slightly.



**CAUTION:** Always keep hands on steering wheel and feet on footrests or step plates when driving Tractor.

4. With Tractor in gear, allow clutch-brake pedal to raise all the way, removing foot from pedal. Do not drive with foot on pedal.

5. Move throttle lever forward until desired speed is attained. If rate of speed is unsatisfactory stop Tractor and shift to a higher or lower gear. Never shift gears while Tractor is moving.

## STOPPING TRACTOR

1. Depress clutch-brake pedal until Tractor stops.
2. Pull throttle lever all the way back.

3. Place gearshift lever in neutral.
4. Place parking brake in engaged position.
5. Turn off ignition and remove key from switch.

*NOTE: In warm weather, especially when Tractor has been working hard for an extended period, allow engine to run at idle for a few minutes. This will permit even cooling and extend engine life.*

6. If Tractor is to be idle for several days, close fuel shut-off valve.

## TRAVEL SPEEDS — MPH

Tractor has four forward speeds and one reverse speed.

1st Gear .....	0.76 mph
2nd Gear .....	2.27 mph
3rd Gear .....	3.9 mph
4th Gear .....	5.9 mph
Reverse .....	3.12 mph

## MOVING BY HAND

If it is necessary to move Tractor without engine power, place gearshift lever in neutral then move Tractor by hand.

*IMPORTANT: Never push or tow Tractor with another vehicle, over 10 mph.*

## ATTACHING IMPLEMENTS

Tractor is equipped with a heavy-duty drawbar, Fig. 13, for attaching pull-behind implements.

A rear lift hitch (Standard on 1600A), Fig. 13, is available to raise or lower rear-mounted implements with implement lift lever.

A rear PTO shield (Accessory item), Fig. 13A, is available and must be installed before operating any attachment that requires rear PTO drive. Except tiller which has PTO shield on its gear box.



**CAUTION:** Never attach pull-behind equipment at any point on Tractor other than drawbar.

For information regarding attachments other than Rotary Mower, refer to Operator's Manual for implement. For information regarding installation and operation of Rotary Mower, refer to Page 27.

## PTO SHIELD INSTALLATION



**CAUTION:** Make sure tractor engine is shut off.

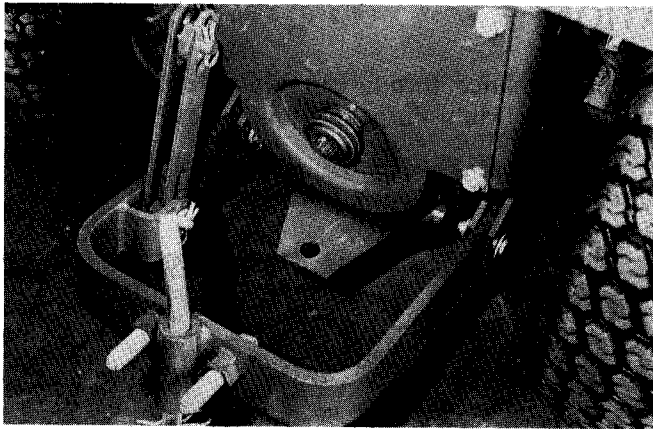

**Fig. 13 — Drawbar and Lift Hitch**

1. Remove and discard two lower bolts from rear PTO cover.
2. Install PTO shield, No. 2, Fig. 13A, to rear PTO cover, No. 1, using 3/8" x 7/8" Hex Head bolts, No. 3.
3. Make sure caution decal is installed on top of PTO shield.

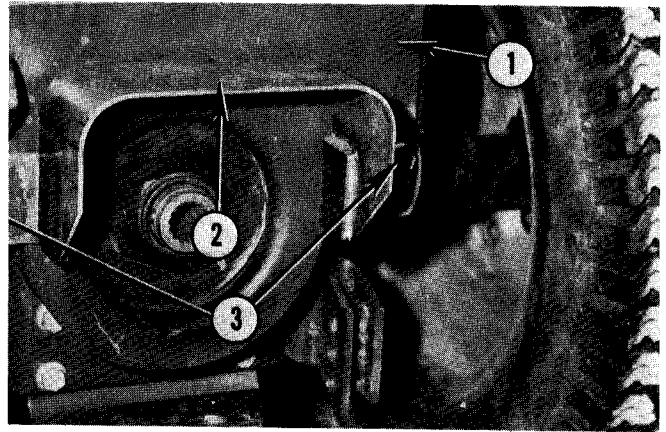

**Fig. 13A — PTO Shield Installation**

1. PTO Rear Cover
2. PTO Shield
3. 3/8" x 7/8" Hex Head Bolts (Two)



# LUBRICATION

Proper lubrication is necessary to ensure trouble-free performance throughout life of unit. Make it a habit to lubricate at recommended intervals. Use a good quality Multi-Purpose lithium base type grease. Always clean grease gun and fittings before and after greasing.

**IMPORTANT:** Never attempt to operate unit unless it is properly lubricated.

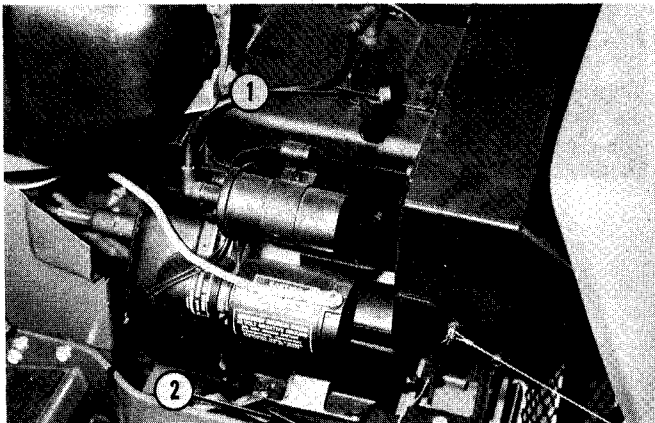

**Fig. 14 — Engine Crankcase Lubrication**

- 1. Dipstick and Fill Point
- 2. Drain Plug — Underneath Engine

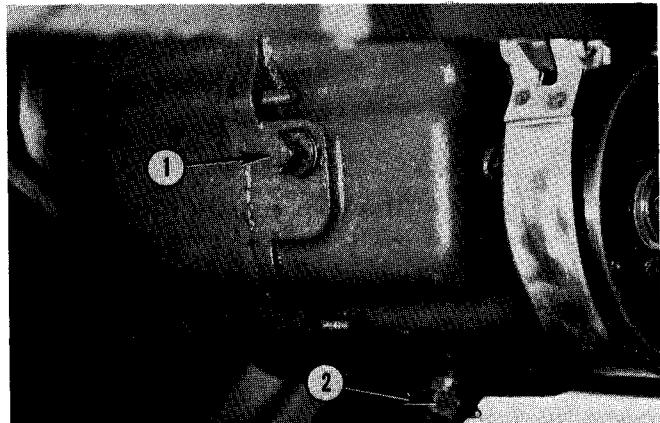

**Fig. 15 — Rear Axle Lubrication**

- 1. Level Plug
- 2. Drain Plug

## AFTER FIRST FIVE HOURS OF OPERATION

Drain crankcase and refill after first five hours of operation. Refer to 25 Hours.

### CHECK CRANKCASE — FIG. 14

Remove dipstick and check oil level before starting engine at beginning of each day's operation. If oil is not to full mark, add to this point. Do not overfill. If overfilled, drain until oil is at full mark on dipstick.

## 25 HOURS

### CHANGE ENGINE CRANKCASE OIL

Drain crankcase with engine stopped and oil warm.

1. Remove crankcase drain plug, Fig. 14.
2. Replace drain plug and fill crankcase, Fig. 14, with SAE 30 oil, Service Class SE/CC (see Temperature Chart).
3. Run engine until warm and check for leaks.
4. Check oil level on dipstick.

### TEMPERATURE CHART

Above 30° F. ....	SAE 30
30° to 0° F. ....	SAE 10W/30
Below 0° F. ....	SAE 5W/20

## REAR AXLE

**IMPORTANT:** Make certain rear axle is properly lubricated before operating Tractor.

Remove oil level plug, No. 1, Fig. 15, on bottom front side of axle and if oil does not run out, fill until it does, using lubricant recommended below. Filler pipe, No. 2, Fig. 16, is located beneath seat. Replace cap, No. 1, on filler pipe and oil level plug after filling.

Use SAE 90 EP Transmission Oil

Capacity ..... 4 U.S., 3.2 Imp. pts.

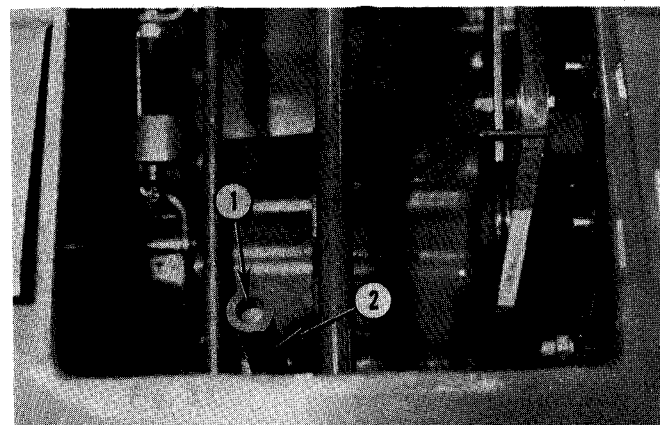

**Fig. 16 — Rear Axle Lubrication**

- 1. Cap
- 2. Filler Pipe

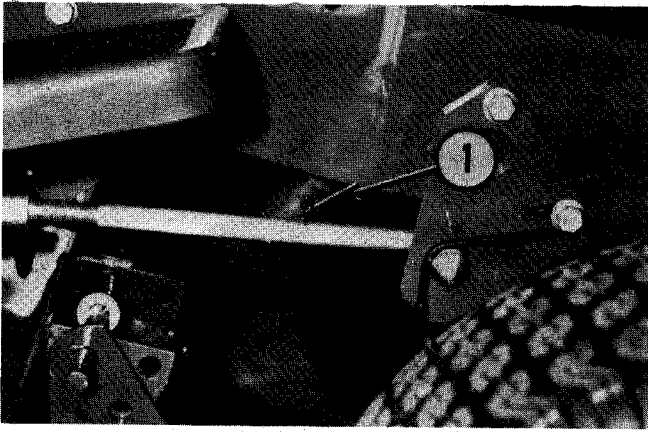

**Fig. 17 — Steering Bellcrank Lubrication**

1. Grease Fitting

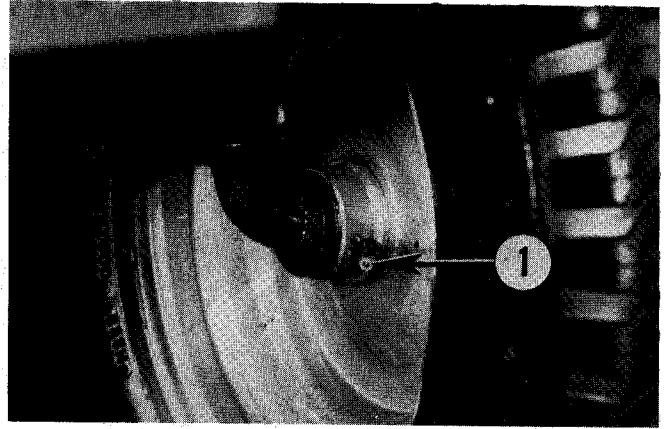

**Fig. 18 — Front Wheel Lubrication**

1. Grease Fitting

## 50 HOURS

### STEERING BELLCRANK

Lubricate fitting, Fig. 17, with two shots of multi-purpose lithium base grease.

### FRONT WHEEL BEARINGS

Lubricate fittings, No. 1, Fig. 18, with two shots of multi-purpose lithium base grease. In addition to the fitting shown in Figure 18, there are two fittings on the spindle and one at the axle pivot point.

## 300 HOURS OR ANNUALLY

### CHANGE REAR AXLE LUBRICANT

Remove filler cap, No. 1, Fig. 16, oil level plug, No. 1, Fig. 15, and drain plug, No. 2. Allow lubricant to drain thoroughly, then clean and replace drain plug securely. Fill through filler pipe, No. 2, Fig. 16, until oil runs out oil level hole, then replace plug and cap securely.

***IMPORTANT:** Do not overfill Tractor rear axle. Make sure Tractor is on level surface and allow oil to run out oil level hole until it stops, when filling.*

# TRACTOR MAINTENANCE

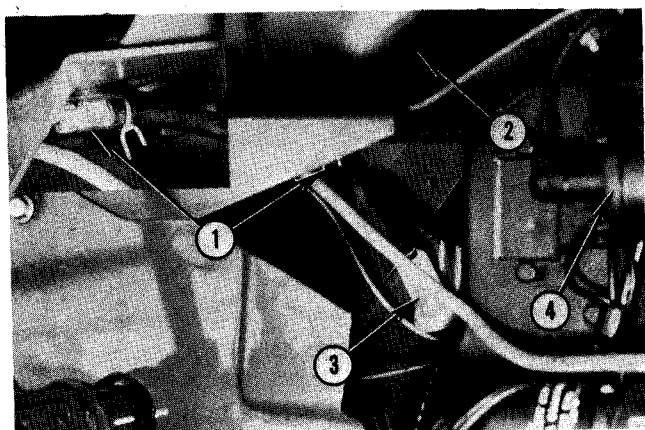

**Fig. 19 — Draining Fuel Tank**

- |                        |                        |
|------------------------|------------------------|
| 1. Fuel Shut-Off Valve | 3. Fuel In-Line Filter |
| 2. Fuel Tank           | 4. Coil                |

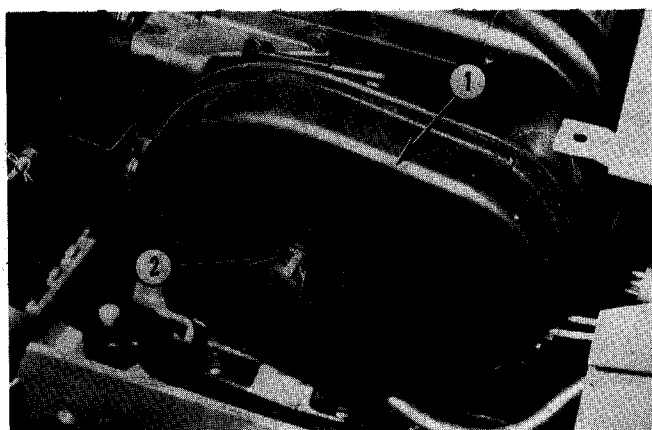

**Fig. 20 — Air Cleaner**

- |                |             |
|----------------|-------------|
| 1. Air Cleaner | 2. Wing Nut |
|----------------|-------------|

## BATTERY — FIG. 12

Check and maintain level of electrolyte every 20 hours of operation, or once each month. Fill slightly above plates with distilled water. Don't overfill. Keep battery posts and cable ends clean and lightly coated with petroleum jelly. Maintain boot on positive post.

## AIR CLEANER — FIG. 20

**IMPORTANT:** If air cleaner becomes too dirty, engine will not receive sufficient air to run properly. Symptoms: Loss of power, flooding, hard to start and overheating.

The air cleaner has a paper element and a polyurethane pre-cleaner. Both must be kept clean for proper engine operation and long life. Clean paper element at least every 50 hours by tapping it lightly on a flat surface. Replace after every 100 to 200 hours of operation. Clean or replace more frequently under severe conditions. Hold a light bulb inside ring to check element. Never wash or oil paper element. If it becomes plugged and cannot be cleaned by tapping, it should be replaced.

Pre-cleaner element will become discolored when dirty. It may be washed in a solvent or non-sudsing detergent and warm water. After washing, allow element to dry thoroughly before replacing in air filter. Never oil pre-cleaner.

**IMPORTANT:** Never run engine with air cleaner removed. Dirt will enter engine and score cylinder.

## TIRES AND WHEELS

Keep treads free of debris and tires inflated to correct pressures. Tires which are overinflated or

underinflated will wear more rapidly. Proper pressures for various tire sizes are as follows:

### FRONT

16 x 6.50-8 ..... 8-10 psi

### REAR

23 x 10.50-12 ..... 6-8 psi

23 x 8.50-12 ..... 6-8 psi

Periodically check front wheel bolts for 30 ft.-lbs. torque. Rear wheel hub bolts (10) should be tightened to 50-60 ft.-lbs. torque.

## FUEL FILTER — FIG. 19

Fuel filter is an in-line filter. If excessively dirty, as viewed through transparent case, shut off fuel valve, remove and replace filter.

Inspect fuel tank at start of each operating season. If water or dirt is present, clean tank and fuel line.

## COOLING SYSTEM

Inspect engine cooling fins frequently and remove any accumulation of debris.

Inspect rotary screen at rear of engine daily for debris plugging screen. To clean, wipe chaff off of rotary screen to engine.

**NOTE:** If air pressure is available, blowing air in reverse direction into fins will dislodge grass or dirt accumulations.

**IMPORTANT:** A dirty screen or fins can cause overheating and damage to engine. Clean them frequently.



**CAUTION:** To prevent a fire hazard, keep engine fins and surrounding area free of grass, leaves and excessive grease.

## SERVICING

This Section is concerned with procedures beyond normal maintenance and care. Most of these operations require above average mechanical ability. It is recommended that these services be performed at least annually. Such services are available, with trained personnel, at your Snapper Dealer.



**CAUTION:** Never operate engine in a poorly ventilated area. Carbon monoxide is odorless, tasteless and deadly.

Never make adjustments on Tractor with engine running unless absolutely necessary. If necessary, exercise extreme caution. Do not wear loose clothing that might become entangled in moving parts.

### SPARK PLUG — FIG. 11

Remove plug and check its condition every 100 hours of operation or annually. If gapping is needed, set at .035". Do not sandblast, wire brush or scrape plug. If needed, replace plug with Champion RH 10.

### BREAKER POINTS

The point cover is located on left front of engine, Fig. 21. Check and service at least every 100 hours of operation or annually. If oxidized, oily or dirty, clean with a coarse cloth. Do not use emery cloth or sandpaper. Replace badly pitted or burned points. To adjust, turn engine over by hand until points are at maximum opening. Check gap with feeler gauge. If gap is not .020", loosen retaining screw and shift plate until proper gap is obtained. Retighten screw, then recheck gap when points are fully open. Replace condenser if necessary.

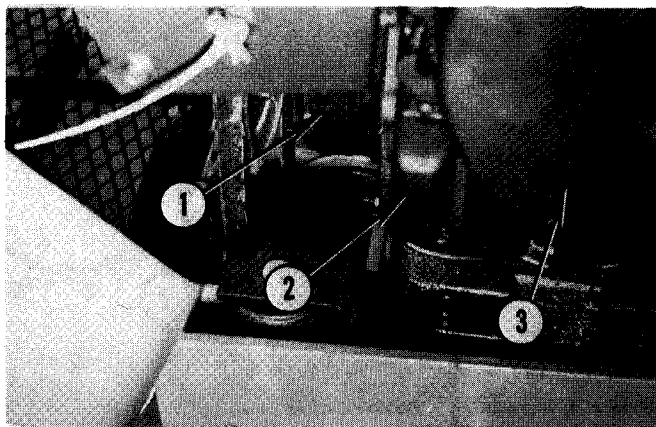

Fig. 21 — Breaker Point Adjustment

1. Implement Drive Clutch
2. Breaker Point Case
3. Air Cleaner

### ENGINE CYLINDER HEAD BOLTS

Within first 25 hours of operation, cylinder head bolts must be retightened to 30 ft.-lbs. torque (with engine at operating temperature). Follow sequence shown in Fig. 22.

### CARBURETOR ADJUSTMENT — FIG. 23



**CAUTION:** Do not touch muffler while adjusting carburetor.

Lack of power and black sooty exhaust smoke usually indicates that fuel mixture is too rich. An overrich mixture may also be caused by a clogged air cleaner — check this before readjusting carburetor. Fuel mixture may be too lean if engine skips or backfires at high speed.

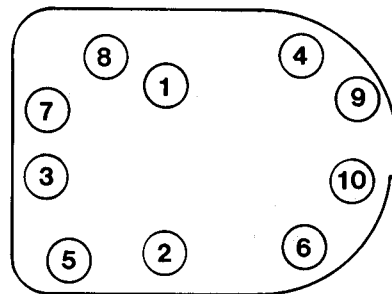
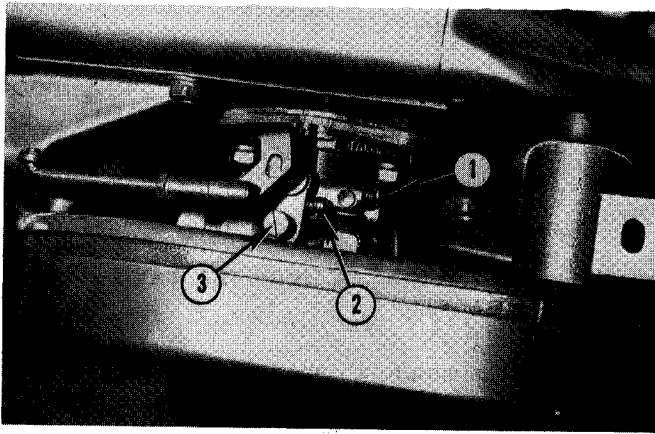

Fig. 22 — Cylinder Head Torque Sequence



**Fig. 23 — Carburetor Adjustments**

- 1. Idle Fuel Screw
- 2. Idle Speed Screw
- 3. Main Fuel Screw

### MAIN FUEL ADJUSTMENT

For preliminary setting turn main fuel screw, No. 3, Fig. 23, in clockwise direction until it bottoms lightly (do not force) then back out two turns. With engine thoroughly warmed up and running at full throttle and full load, turn main fuel screw in until engine slows (lean setting) then turn screw out until engine regains speed and then starts to slow down (overrich setting). Turn screw back in until it is positioned halfway between lean and overrich settings — when properly adjusted engine will accelerate smoothly and operate with steady governor action.

### IDLE ADJUSTMENT

Rough idle is usually caused by idle speed being set too low. Turn idle speed screw, No. 2, in clockwise direction to increase speed. If engine still idles poorly after speed is increased, stop engine and turn idle fuel screw, No. 1, all the way in (clockwise) until it bottoms lightly (do not force screw), then back out 1-1/4 turns. Restart engine and check idle — turn needle in or out (1/4 turn at a time) until smoothest idle is achieved. Idle speed should be 2100-2300 rpm.

*NOTE: If these adjustments do not correct carburetor problems, carburetor should be removed and overhauled.*

### GOVERNOR ADJUSTMENT

The governor functions to maintain engine speed under changing load conditions and also acts as a speed limiting device. Governors are set at the factory and further adjustment should not be required unless linkage works loose or becomes disconnected. Readjustment should be made if engine surges with changing load or if speed drops considerably when a normal load is applied.

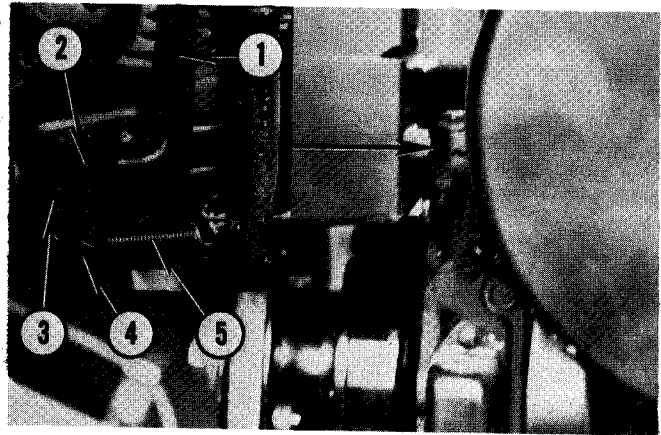

**Fig. 24 — Governor Adjustment**

- 1. Governor Arm
- 2. Cross Shaft
- 3. Hex Nut
- 4. Governor Control Bracket
- 5. Spring

### INITIAL ADJUSTMENT

With engine stopped, loosen (do not remove) hex nut, No. 3, Fig. 24, securing governor arm, No. 1, to governor cross shaft, No. 2. Grasp end of cross shaft with pliers and turn shaft as far as possible in counterclockwise direction — tab on shaft will stop internally against governor gear mechanism. Hold shaft in this position, pull governor arm all the way away from carburetor then retighten governor arm nut to complete initial adjustment.

### SPEED ADJUSTMENT

Maximum allowable speed is 3600 rpm. This speed must not be exceeded. If overspeed condition is suspected, check rpm's with hand tachometer and readjust as follows:

Adjust high speed stop screw, No. 2, Fig. 25, until correct maximum speed is attained.

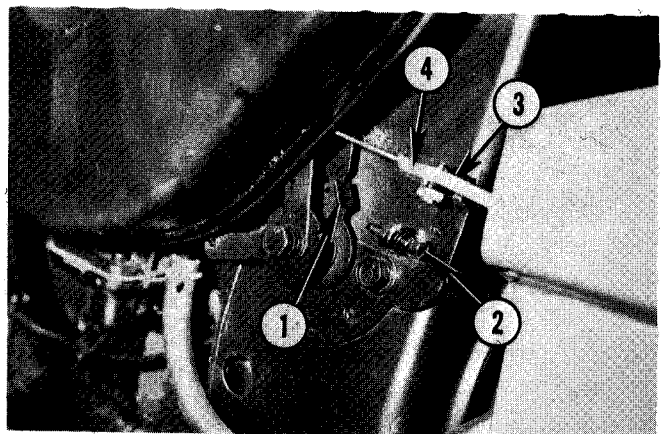

**Fig. 25 — Governor Adjustment**

- 1. High Speed Bracket
- 2. High Speed Stop Screw
- 3. Throttle Control Cable — Behind Choke Cable
- 4. Choke Cable

## SENSITIVITY ADJUSTMENT

If speed drops considerably when a normal load is applied, governor should be set for greater sensitivity. If set too sensitive, speed surging will occur with changing load. Governor sensitivity is adjusted by repositioning governor spring, No. 5, Fig. 24, in holes provided on governor control bracket, No. 4, and speed bracket, No. 1, Fig. 25. Increase tension on spring (and sensitivity) by moving spring hooks into holes spaced further apart — conversely, decrease sensitivity by reducing tension on spring.

## POWER TAKE-OFF BELTS (OPTIONAL) —

*NOTE: Front belt adjustment and replacement requires removal of left-hand side panel.*

### FRONT BELT ADJUSTMENT

Proper tension of drive belts is when length of spring, No. 4, Fig. 26, is 1-1/4". Check measurement and if necessary adjust nuts, No. 2, until correct spring length is obtained (1-1/4"). (Also see Fig. 27.)

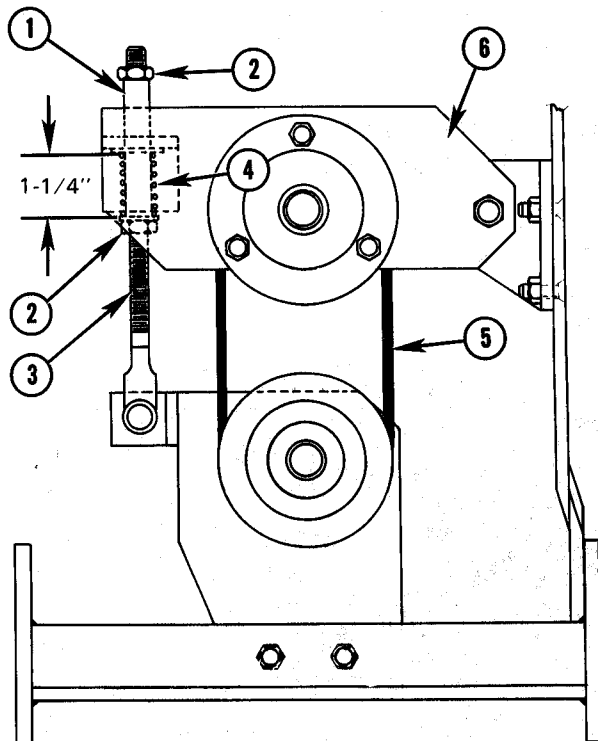

**Fig. 26 — PTO Front Belt Adjustment — Rear View**

- |                   |                   |
|-------------------|-------------------|
| 1. Sleeve         | 4. Spring         |
| 2. Adjusting Nuts | 5. Belts          |
| 3. Rod            | 6. Pulley Bracket |

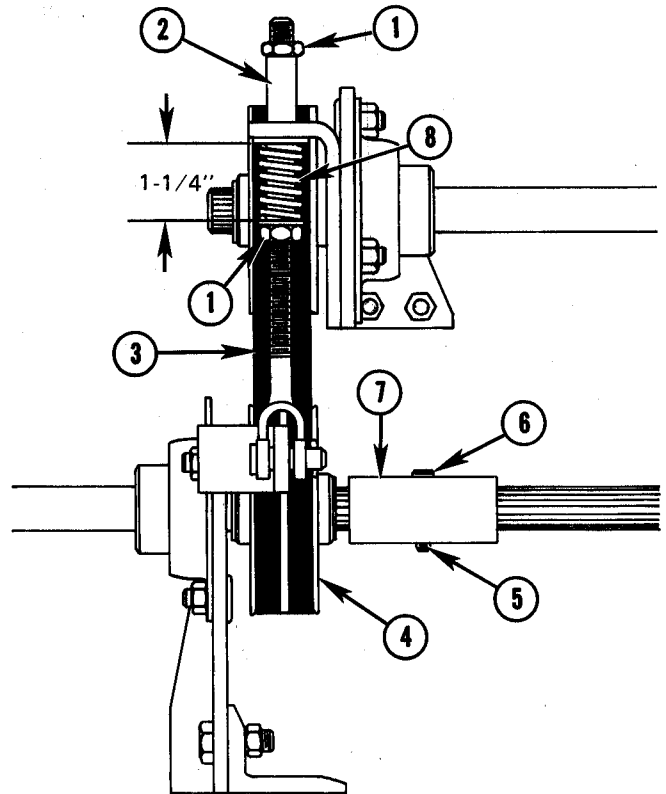

**Fig. 27 — PTO Front Belt Replacement**

- |                   |               |
|-------------------|---------------|
| 1. Adjusting Nuts | 5. Cotter Pin |
| 2. Sleeve         | 6. Clevis Pin |
| 3. Belts          | 7. Coupling   |
| 4. Lower Pulley   | 8. Spring     |

### FRONT BELT REPLACEMENT

*NOTE: Belts must be replaced as a matched set.*

1. Loosen lower adjusting nut, No. 1, Fig. 27, lower upper pulley bracket, No. 6, Fig. 26, and remove belts, No. 5.
2. Remove cotter pin, No. 5, Fig. 27, and clevis pin, No. 6. Slide coupling, No. 7, rearward and remove belts, No. 3, from lower pulley, No. 4.
3. Install new set of belts around upper and lower pulleys.
4. Slide coupling forward and secure with clevis pin and cotter pin.
5. Adjust belt tension.

### REAR BELT ADJUSTMENT

*NOTE: This can be done without removing fender or rear PTO cover plate.*

To adjust belt tension on rear PTO:

1. Loosen nut, No. 1, Fig. 28.
2. Push idler arm and pulley, No. 3, towards centerline of Tractor to remove slack from belts, No. 4.

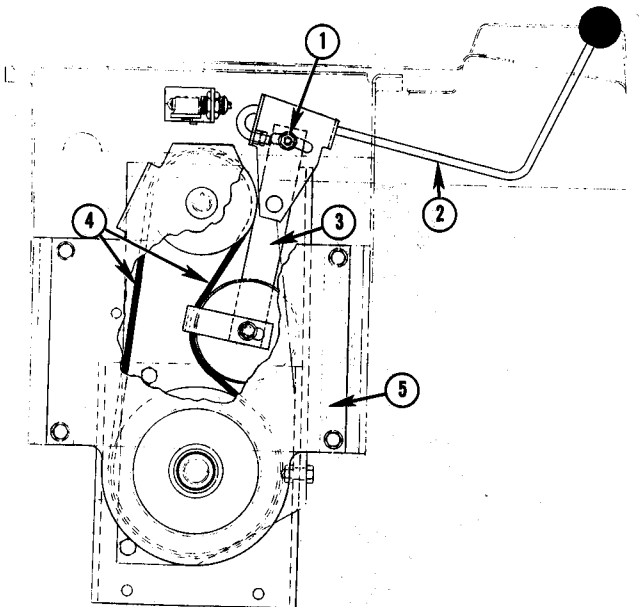

**Fig. 28 — Rear PTO Belt Adjustment**

- |                  |                         |
|------------------|-------------------------|
| 1. Adjusting Nut | 3. Idler Arm and Pulley |
| 2. Control Lever | 4. Belts                |
|                  | 5. PTO Cover Plate      |

3. Place control handle, No. 4, Fig. 3, in center of slot in fender.

4. Tighten nut, No. 1, while maintaining relative position of idler arm and lever (Steps 2 and 3).

5. Spring steel handle then provides sufficient force to properly tension V-belts in engaged position.

### REAR BELT REPLACEMENT

*NOTE: Belts must be replaced as a matched set.*

1. Remove rear PTO cover plate, No. 5, Fig. 29, and loosen belt tension.

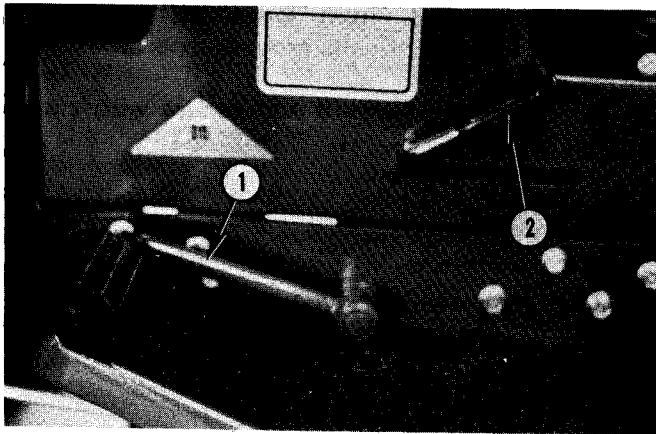

**Fig. 29 — Brake Adjustment**

- |                       |                        |
|-----------------------|------------------------|
| 1. Clutch-Brake Pedal | 2. Parking Brake Lever |
|-----------------------|------------------------|

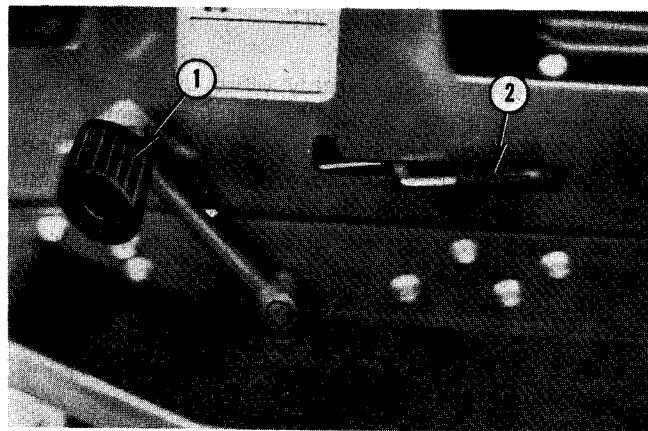

**Fig. 30 — Brake Adjustment**

- |                       |                        |
|-----------------------|------------------------|
| 1. Clutch-Brake Pedal | 2. Parking Brake Lever |
|-----------------------|------------------------|

2. Remove old belts and install matched set of new belts.

3. Adjust belt tension and reinstall PTO cover plate.

### BRAKE ADJUSTMENT

1. Depress clutch-brake pedal, No. 1, Fig. 29, and engage parking brake lever, No. 2.

2. If lever will not engage, raise Tractor seat, remove tool box.

3. With clutch-brake pedal, No. 1, Fig. 30, in up position, increase clearance between bolt head, No. 5, Fig. 31, and brake arm, No. 4. Repeat Step 1 and readjust if necessary. Tighten jam nut, No. 3.

### TRANSAXLE BELT GUIDE ADJUSTMENT

Check clearance between belt, No. 3, Fig. 32, and belt guide, No. 5. If clearance is not 1/16", loosen nut, No. 4, and adjust guide until correct clearance is obtained. Tighten nut.

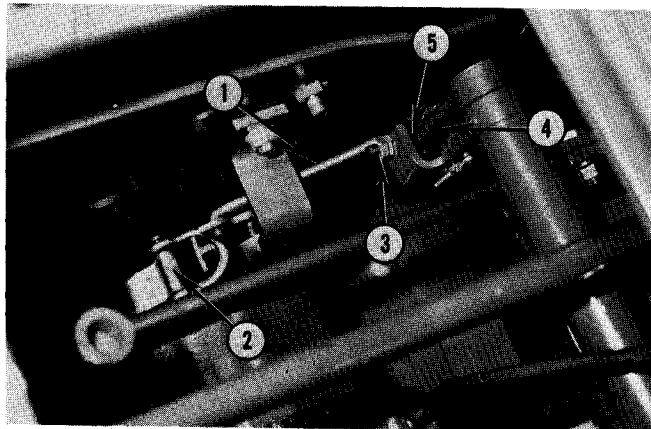

**Fig. 31 — Brake Adjustment**

- |                       |              |
|-----------------------|--------------|
| 1. Brake Actuator Rod | 3. Jam Nut   |
| 2. Brake Band         | 4. Brake Arm |
|                       | 5. Bolt Head |

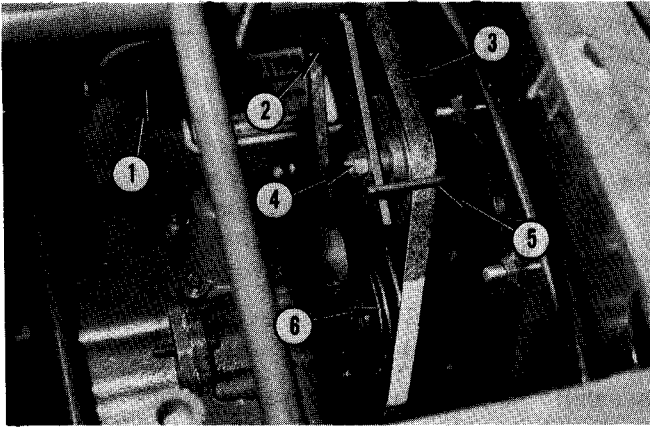

**Fig. 32 — Transaxle Drive Line**

- |                 |                              |
|-----------------|------------------------------|
| 1. Gearbox      | 4. Idler Pulley Bolt and Nut |
| 2. Drive Pulley | 5. Belt Guide                |
| 3. Belt         | 6. Driven Pulley             |

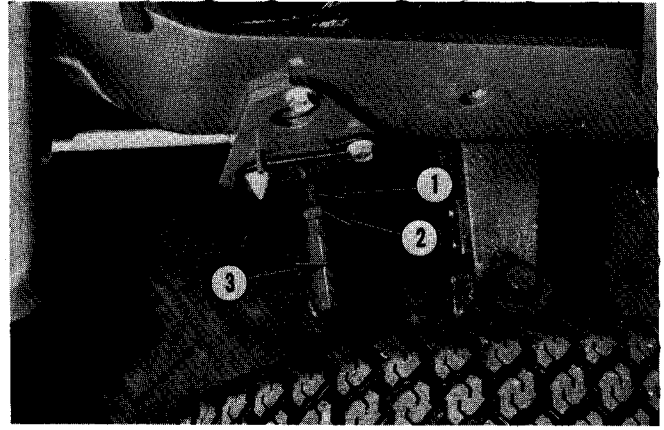

**Fig. 33 — Toe-In Adjustment**

- |            |             |               |
|------------|-------------|---------------|
| 1. Tie-Rod | 2. Lock Nut | 3. Ball Joint |
|------------|-------------|---------------|

## TOE-IN

With wheels pointed straight ahead, check toe-in by measuring distance between front wheels at front and rear. Dimensions at front edge should be 1/8" less than at rear. If adjustment is needed, loosen tie-rod lock nut, No. 2, Fig. 33, at each end of tie-rod, No. 1, and turn tie-rod until correct toe-in is obtained.

## WIRING

Should wiring become disconnected, or require replacement, refer to wiring diagram, Page 24, for proper connections.

## IGNITION SWITCH

The ignition switch has 4 positions as follows.

1. Off and key removal.
2. On/Running with lights.
3. On/Running without lights.
4. On/Start.

## SAFETY START SWITCHES

The function of these switches is to allow the engine to start when the following safe starting conditions exist.

1. Operator seated in tractor's seat.

2. Clutch/Brake pedal depressed.
3. Front PTO switch is OFF position.
4. Rear PTO (if tractor so equipped) lever in OFF position.

The mechanism controlling condition, No. 1, above is in the engine ignition circuit. The mechanisms controlling conditions, No. 2, 3 and 4, above are in the engine cranking circuit. Therefore, it is important to remember that ALL these safe starting conditions must exist before the engine will start. Also, if safe starting conditions, Nos. 2, 3 and 4, exist the engine *will crank over* using the starter *but will not start* if safe starting condition, No. 1, is not existing.

For repair of any of these safety start mechanisms, contact your Dealer.

## TRACTOR STORAGE

If Tractor is to be idle for an extended period of time, it should be prepared for storage.

1. Store Tractor in a dry area where it will be protected from weather.
2. Open fuel shut-off valve, No. 1, Fig. 19, and drain all fuel from tank, close valve. Start engine and run until it runs out of fuel.
3. Remove spark plug, No. 1, Fig. 12, and put a tablespoon of engine oil into spark plug hole. Turn engine over two or three times with starter and regap spark plug to .025" and replace. Leave spark plug wire disconnected.



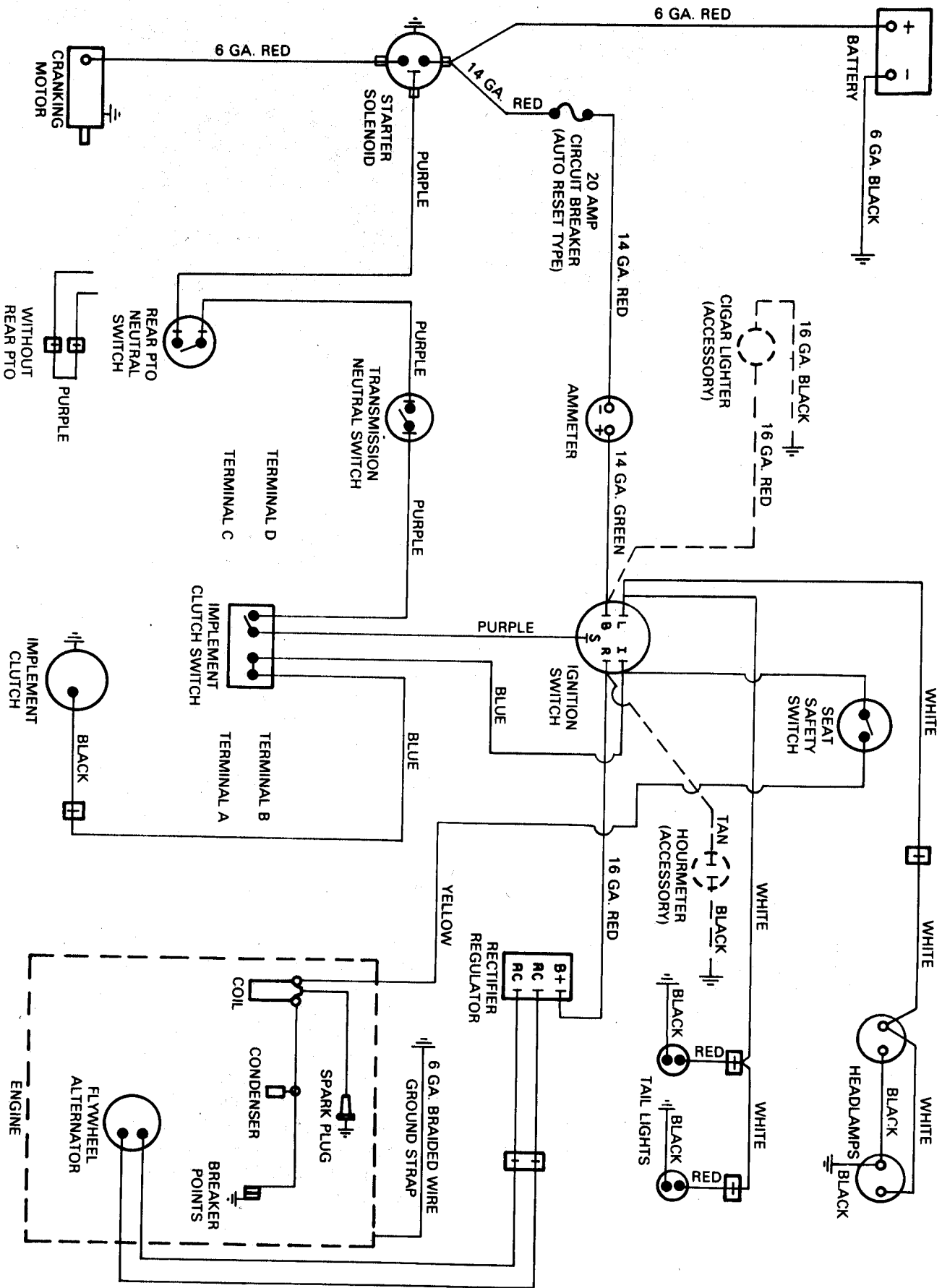

NOTE: All wires 18 gauge unless otherwise specified.

Wiring Diagram

4. Lubricate fully as described in "Lubrication" Section.

5. Remove battery, clean case and terminals thoroughly. Coat terminals with a thin coating of petroleum jelly. Charge battery and store in a cool dry place. Do not store on a cement floor. Recharge at least monthly while in storage.

## REMOVING TRACTOR FROM STORAGE

1. Install fully charged battery, placing boot over positive terminal.

2. Clean or replace air filter element. Refer to "Maintenance" Section for procedure.

3. Check crankcase oil level. If needed, drain after running engine until warm, and refill.

4. Move Tractor outside and fill fuel tank. Connect spark plug wires and run engine several minutes before placing Tractor under load.

5. Check transmission oil level. Fill using procedure prescribed in "Lubrication" Section.

6. Check tire pressures. Refer to "Maintenance" Section for correct pressures.

## TROUBLE-SHOOTING

*NOTE: Clutch brake switch and front and rear PTO switch must make a circuit when pedal is down and rear PTO lever is in disengaged position. Seat switch has an open circuit when seat is "Up" and makes a circuit when operator is seated.*

### ENGINE

#### HARD STARTING OR LOSS OF POWER

1. Faulty ignition.
  - a. Leads grounded or loose.
  - b. Breaker points faulty or improperly gapped.
  - c. Spark plug faulty or improperly gapped.
  - d. Coil or condenser defective.
2. Faulty carburetion.
  - a. Fuel line or filter clogged (dirt, gum, etc.).
  - b. Fuel pump faulty.
  - c. Carburetor dirty or improperly adjusted.
3. Poor compression.
  - a. Head loose or gasket leaking.
  - b. Valve sticking or leaking.
  - c. Piston rings worn.

## WON'T START

Check safety switches.

1. If engine won't crank check clutch brake pedal and front and rear PTO switches.
2. If engine cranks but does not start check seat switch.

## OPERATING ERRATICALLY

1. Clogged fuel line.
2. Water in fuel.
3. Vent in gas cap plugged.
4. Faulty fuel pump.
5. Gasket leaking (carburetor-manifold).
6. Governor improperly set.
7. Carburetor improperly adjusted.

## KNOCKING

1. Fuel octane too low.
2. Ignition timing wrong.
3. Carbon build-up in combustion chamber.
4. Engine overheated.

## OCCASIONAL SKIP AT HIGH SPEED

1. Spark plug fouled, faulty or gap too wide.
2. Ignition timing wrong.
3. Carburetor improperly adjusted.
4. Breaker points faulty or improperly adjusted.

## OVERHEATING

1. Air intake screen or fins clogged.
2. Oil level too high (or low).
3. Fuel mixture too lean.
4. Ignition timing wrong. Spark too far advanced.
5. Engine overloaded.
6. Tappet clearance too close.

## IDLES POORLY

1. Idle speed too low.
2. Idle fuel improperly adjusted.
3. Gasket leaking (carburetor-manifold).
4. Spark plug gap too close.

## BACKFIRING

1. Carburetor set too lean (main fuel).
2. Breaker points improperly gapped (timing).
3. Valve sticking.

# TRACTOR SPECIFICATIONS

## ENGINE:

Model .....	Kohler K341AQS
Cylinders .....	1
Horsepower .....	16 @ 3600 rpm
Displacement .....	35.89 cu. ins.
Bore .....	3.75 inches
Stroke .....	3.25 inches
Crankcase Oil Capacity .....	4 pints
Weight .....	120 pounds
Ignition .....	12 volt
Fuel System .....	Internally vented float carburetor and fuel pump
Cooling System .....	Air cooled
Idle Speed .....	2100-2300 rpm
Governed Speed (No Load) .....	3600 rpm
Air Intake System .....	Intake to air cleaner through fan

## TRANSAXLE:

Model .....	Peerless 2300 series
System Capacity .....	4 U.S. qts.

Fuel Tank Capacity ..... 2-3/4 gallons

Battery ..... 12 volt — 46 ampere hour

## CHASSIS:

Wheelbase .....	47 inches
Length (Overall) .....	70-3/4 inches
Width .....	41-1/2 inches
Height (Over Steering Wheel) .....	45-1/2 inches
Ground Clearance (Under Step Plates) .....	13-1/2 inches
Front Wheel Tread .....	30 inches
Rear Wheel Tread .....	30-1/2 inches
Drawbar Height .....	8-1/4 inches

## TIRES:

Front .....	16 × 6.50-8 2 Ply
Rear .....	23 × 10.50-12 2 Ply

Front PTO — Standard ..... Electric clutch with V-belt pulley and idler pulleys

Rear PTO — Standard 1600A (Optional-1600) ..... Speed 2000 rpm

Weight (Approx.) without Mower ..... 760 lbs.

ACCESSORIES: ..... See your Snapper Dealer

# ROTARY MOWER

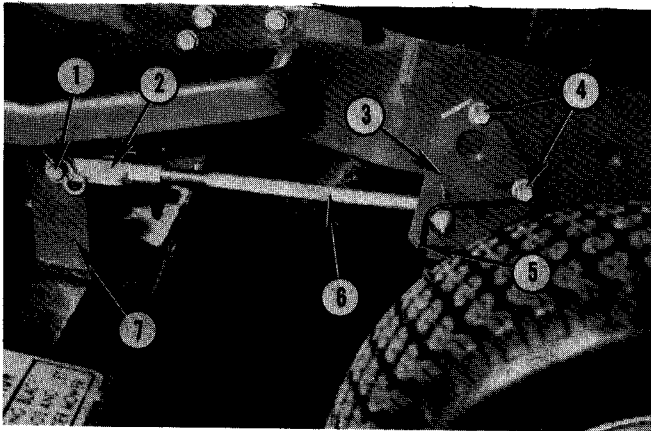

**Fig. 34 — Preparing Tractor**

1. Clevis Pin and Hair Pin
2. Yoke
3. Anchor Plate — Front
4. 3/8" x 1-1/4" Hex Head Bolts, Flange Lock Nuts
5. Link Springs (Four Used — Two Right-Hand, Two Left-Hand)
6. Lifter Link
7. Mower Bracket

## INSTALLATION

### PREPARING TRACTOR

*NOTE: Rear anchor plates are installed on inside of frame.*

1. Bolt anchor plates and link springs to Tractor frame (each side). Secure with 3/8" x 1-1/4" bolts and flange lock nuts. Tighten nuts finger tight, then tap lower end of front brackets rearward and lower end of rear brackets forward.

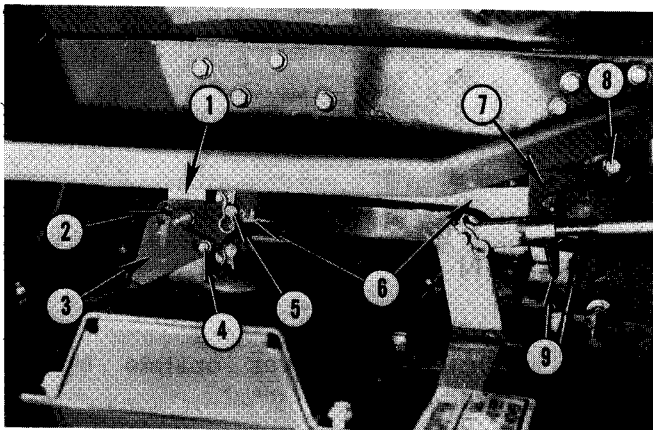

**Fig. 35 — Preparing Tractor**

1. Hanger Straps
2. Link Spring
3. Mower Bracket
4. 1/4" x 3/4" Hex Head Bolt and Flange Lock Nut
5. Clevis Pin and Hair Pin
6. Lift Arm
7. Anchor Plate — Rear
8. 3/8" x 1-1/4" Hex Head Bolt and Flange Lock Nut
9. Link Spring

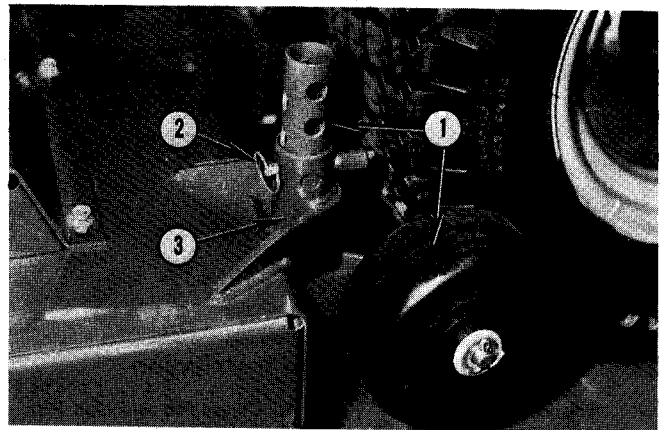

**Fig. 36 — Preparing Mower**

1. Gauge Wheel
2. Klik Pin
3. Bracket

*NOTE: The purpose of this is to seat parts in their eventual position to prevent a second levelling of the mower.*

2. Tighten nuts to 40 ft.-lbs. torque, Figs. 34 and 35.
3. Attach hanger straps to outside of Tractor lift arms with flatwashers and cotter pins. These parts may be retained on Tractor when mower is detached, see Fig. 35.

### PREPARING MOWER

1. Install link springs, No. 2, Fig. 35, on outside of mower rear attaching brackets, No. 3, with 1/4" x 3/4" Hex Head bolt and flange lock nut, No. 4.
2. Install center lift links, No. 6, with clevis pin and hair pin, No. 5.
3. Install gauge wheel unit, No. 1, Fig. 36, to bracket, No. 3, and secure with klik pin, No. 2. Repeat for other side.
4. Install chute with bolt heads down.

*NOTE: Rear chute to be installed after mower is on Tractor unless mounting ramps are used.*

### ATTACHING

1. Slide mower under Tractor from right side or, using mounting ramp, (Accessory), drive Tractor over mower. Refer to Page 30 for proper use of mounting ramps.
2. Lower lift arms.
3. Attach lift arms, No. 4, Fig. 37, to rear anchor plate, No. 3, and hanger straps, No. 1, Fig. 35, to mower. Secure in place with link springs.
4. Relocate gauge wheels in full up position.
5. Install lifter link, No. 7, to front anchor plates, No. 1, and secure with link spring. Adjust yoke, No. 6, until holes line up and secure with clevis pin and hair pin, No. 5.

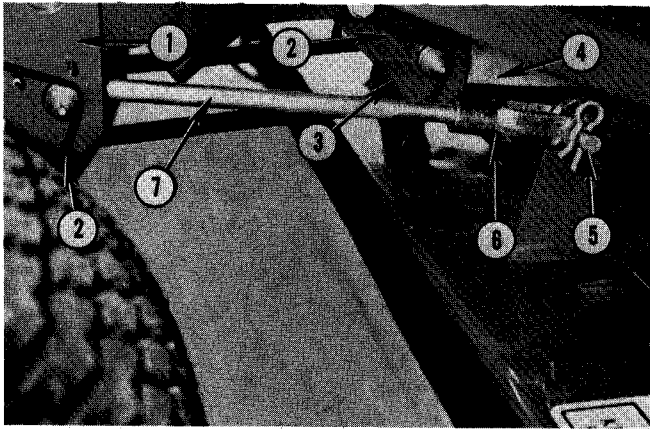

**Fig. 37 — Mower Installation**

- |                         |                            |
|-------------------------|----------------------------|
| 1. Anchor Plate — Front | 5. Clevis Pin and Hair Pin |
| 2. Link Springs         | 6. Yoke                    |
| 3. Anchor Plate — Rear  | 7. Lifter Link             |
| 4. Lift Arm             |                            |

6. Remove mule drive cover by removing two retaining bolts.

7. Remove mule drive unit by removing two pins, No. 4, Fig. 39.

8. Attach mower drive belt, No. 2, Fig. 38, to pulley, No. 1, on implement drive clutch, No. 3.

9. Reinstall mule drive and cover.

10. Rotate bolt, No. 6, counterclockwise and install belt, No. 2, over left pulley, No. 7, then around pulley, No. 5, Fig. 40, on mower.

11. Raise spring-loaded right pulley, No. 5, Fig. 39, and install belt, No. 1, around pulley.

12. Rotate bolt, No. 6, clockwise until both pulleys are at same height. Install cover, No. 4, Fig. 41, with 5/16" x 7/8" Hex Head bolts and washers.

13. If mower is not level refer to "Levelling", Page 30.

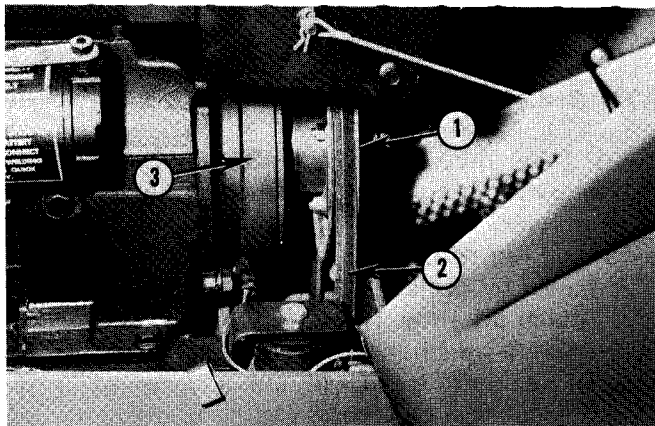

**Fig. 38 — Mower Installation**

1. Pulley
2. Mower Drive Belt
3. Implement Drive Clutch

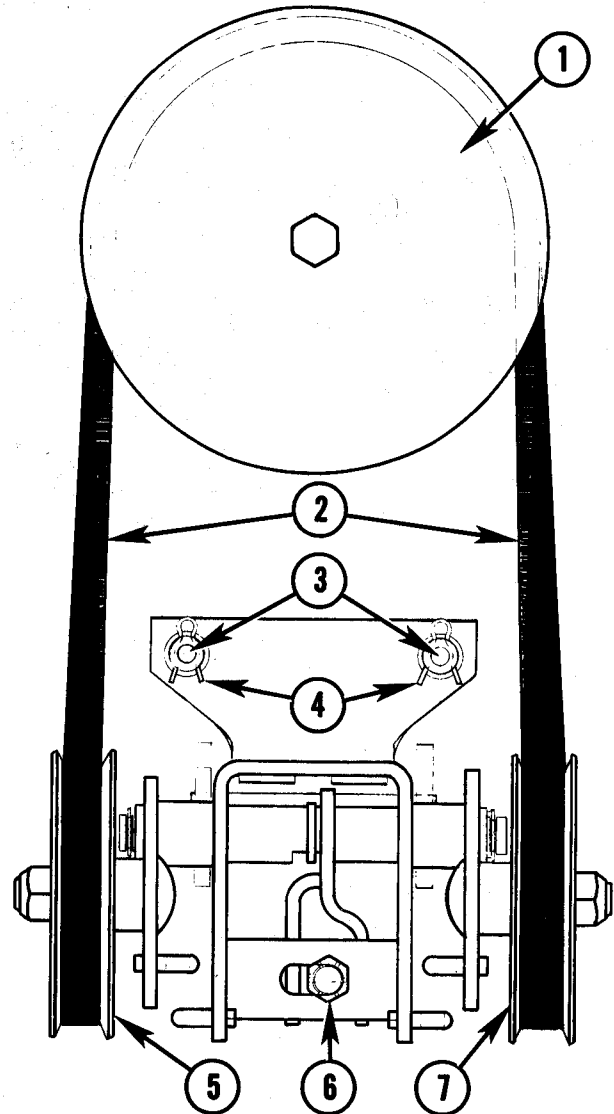

**Fig. 39 — Mower Installation**

- |                                    |                         |
|------------------------------------|-------------------------|
| 1. Pulley — Implement Drive Clutch | 4. Cotter Hair Pins     |
| 2. Belt                            | 5. Spring-Loaded Pulley |
| 3. Pins                            | 6. Adjusting Bolt       |
|                                    | 7. Pulley — Left-Hand   |

## OPERATION



**CAUTION: Never operate Mower with shields removed.**

Always check area to be mowed before operating. Remove sticks, stones, bones or other material that could come in contact with blades and be thrown and cause injury to persons, or damage to implements. Take note of any obstructions that cannot be moved and might be difficult to see when operating. Mark small pipes, curbs or other objects that are difficult to see, as a warning.

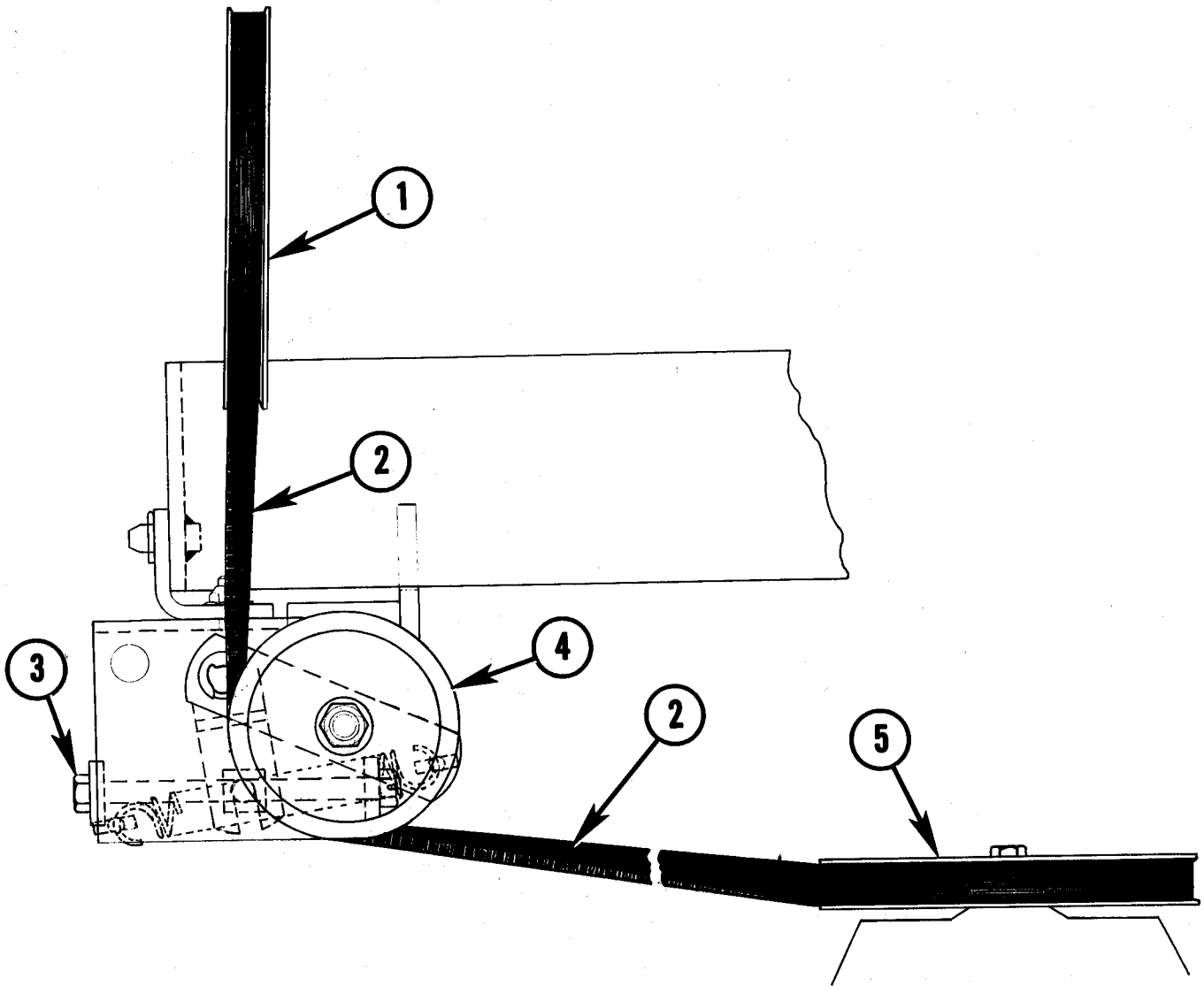

**Fig. 40 — Mower Installation**

- 1. Pulley — Implement Drive Clutch
- 2. Belt
- 3. Adjusting Bolt
- 4. Pulley — Left-Hand
- 5. Mower Pulley

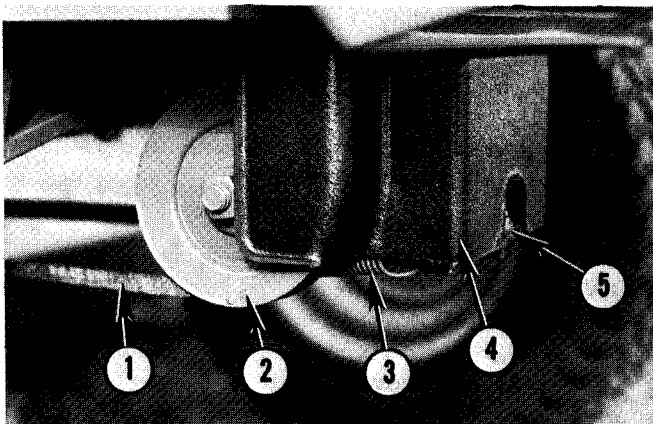

**Fig. 41 — Mower Installation**

- 1. Belt
- 2. Spring-Loaded Pulley
- 3. Spring
- 4. Cover
- 5. Adjusting Bolt

Should anything solid come in contact with mower blades, stop Tractor and shut-off engine immediately. Carefully inspect both Tractor and mower. If needed, make repairs or adjustments before proceeding. Mower blade drive is protected by shear pins in blade mounting assembly. If blades get out of time and strike each other stop immediately. Replace shear pins and retime blades. Blades can be retimed by shifting blade mounting assembly on square end of spindle shafts, Page 31.

**IMPORTANT:** Check shear pins on all blades.

When crossing gravel driveways, walks, etc., or when in transport, always disengage implement drive and raise mower all the way up.

To mow, proceed as follows:

- 1. While on Tractor seat, depress the clutch —

brake pedal and disengage PTO drives. Start Tractor engine, allowing a few minutes for warm-up, and drive to area to be mowed.

2. In grass of normal height, lower mower to desired cutting height. In unusually heavy grass or weeds, lower mower partially, go over area once, then go over area again with mower lowered to normal cutting height. Cutting height is adjustable from 1-1/2" to 4" by means of implement lift lever.

3. Always operate with throttle set at from 3/4 to full throttle. Forward speed should be approximately 3.5 mph, under good conditions, for best mowing results.

4. Engage implement drive by engaging implement clutch switch, Fig. 1.

5. Place gear shift lever in desired range and then slowly let up on the clutch/brake pedal with your foot. Do not mow in reverse with rear discharge mower.



**CAUTION: Turn off engine while unclogging discharge chute.**

## DETACHING

1. Raise Mower up with mid mounted implement lever. Shut off Tractor engine. Place gauge wheels in top hole.

2. Lower mower to ground.

3. Disconnect lifter links and center lift arms from anchor plates.

4. Disconnect hanger straps from mower and remove rear discharge chute on rear discharge mower.

5. Slide mower out from under tractor on right side, or back over mower using mower Accessory Kit Mounting Ramp.

## ATTACHING AND DETACHING MOWER USING MOWER MOUNTING RAMPS (OPTIONAL)

### ATTACHING

1. Position ramps at rear of mower with one end under gauge wheel shaft and other resting on ground.

2. Drive Tractor up ramps until front wheels are resting on belt shield. Shut engine off.

3. Reposition ramps to front of mower. Start engine and drive Tractor forward until mower is directly underneath Tractor. Shut off engine and proceed to attach mower to Tractor.

## DETACHING

1. Detach mower from Tractor. If mower has rear discharge remove chute.

2. Position mounting ramps at front of mower.

3. Start Tractor and back up until front wheels are resting on belt shield. Shut off engine.

4. Reposition ramps to rear of mower under gauge wheel shaft.

5. Start engine and continue to back up until Tractor is clear of mower.

## MOWER ADJUSTMENTS

### LEVELLING

With Tractor on level surface and tires correctly inflated, place 2 x 4" edgewise under front center of mower and gauge wheels in full up position. Shorten adjusting links, No. 7, Fig. 37, sufficiently so that they will just enter brackets, No. 1. Press links into place with latch springs in grooves of front link pins.

### MOWER DRIVE BELT TENSION

1. Make sure mower is level before attempting to adjust belt tension.

2. With mower in lowered position, turn adjusting bolt, No. 6, Fig. 39, clockwise to adjust belt tension. When belt, No. 2, is properly tensioned, pulleys, Nos. 5 and 7, should be approximately same height from ground.

### MOWER DRIVE BELT REPLACEMENT

1. Remove mule drive cover and mule drive.

2. Rotate adjusting bolt, No. 3, Fig. 40, counter-clockwise to relieve belt tension.

3. Pry up right pulley, No. 5, Fig. 39, and remove belt, No. 2, from pulley.

4. Remove belt from left pulley, No. 7, from pulley, No. 5, Fig. 40, on mower and from pulley, No. 1.

5. Install new belt, adjust tension and reinstall mule drive and mule drive cover.

### MOWER BELT TENSION

#### — FIGS. 42 AND 43

1. Remove belt covers and measure length of spring, No. 4, Fig. 43. If measurement is not 4.38" adjustment is necessary.

2. Tighten central mower spindle housing bolts.

3. Loosen outboard spindle housing nuts, No. 2, Fig. 42, one turn only.

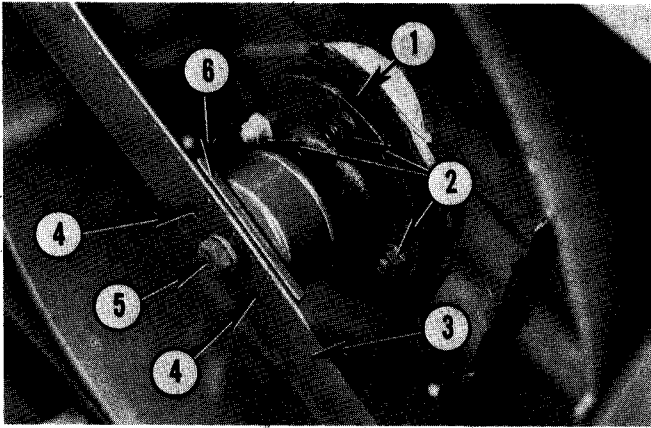

**Fig. 42 — Belt Adjustment**

1. Spindle Housing
2. 3/8" x 1-1/8" Round Head Bolts and Flange Lock Nuts
3. Mower Blade
4. Shear Pins
5. Bolt, Belleville Washer and Lockwasher
6. Adaptor

4. Loosen nuts, Nos. 1 and 2, Fig. 43, completely which will allow springs, No. 4, to move spindles outboard to tension belts.

5. Tap spindle housing, No. 1, Fig. 42, under mower base with a hammer to overcome any friction at mounting bolts.

6. Again check length of spring. If measurement is less than 4.38" remove washer, No. 3, Fig. 43. If measurement is more than 4.38" add washers between spring and anchor bracket until spring length is correct.

7. Tighten nuts, Nos. 1 and 2, until there is 1/16" clearance between nut, No. 2, and anchor bracket.

8. Tighten spindle housing bolts, No. 2, Fig. 42, to 30-35 ft.-lbs. torque. Reinstall belt covers.

#### BELT REPLACEMENT — FIG. 44

1. Remove mower from Tractor.
2. Remove belt covers and back off nuts on outboard spindle housing mounting bolts one turn. Tighten nuts on belt tensioning bolts to bring outboard spindles inboard to slacken belts.
3. Remove top belt, then bottom belt. Install new belts in reverse order.
4. Adjust tension of bottom belt first then top belt, Page 30. Replace covers.

#### REPLACING BLADES

Wrap blade with heavy cloth and hold while loosening bolt. Note order components are taken off so they can be replaced same way. Blades are attached to spindle by means of blade adaptor, two shear pins and a bolt with a belleville spring washer and a lockwasher, Fig. 42.

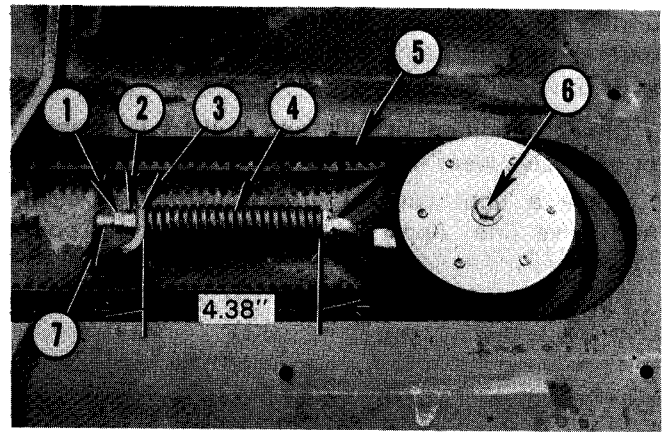

**Fig. 43 — Belt Adjustment**

- |                         |           |
|-------------------------|-----------|
| 1. Jam Nut              | 4. Spring |
| 2. Adjusting Nut        | 5. Belt   |
| 3. Washer               | 6. Pulley |
| 7. Belt Tensioning Bolt |           |

When sharpening blades on a grinder, take care not to overheat or metal will lose its temper. Grind each blade edge equally so that blade balance will be maintained. Replace blade and attaching parts in same order as removed. Tighten nut to 45 ft.-lbs. torque.

*NOTE: Mower blades must be properly timed. The two outboard blades must be in line (parallel to each other) and center blade at 90° (perpendicular to outboard blades).*

#### MOWER STORAGE

When mowing season is over, remove mower from Tractor and clean it carefully.

Remove shields from top of Mower and clean interior carefully. Remove all grass deposits from

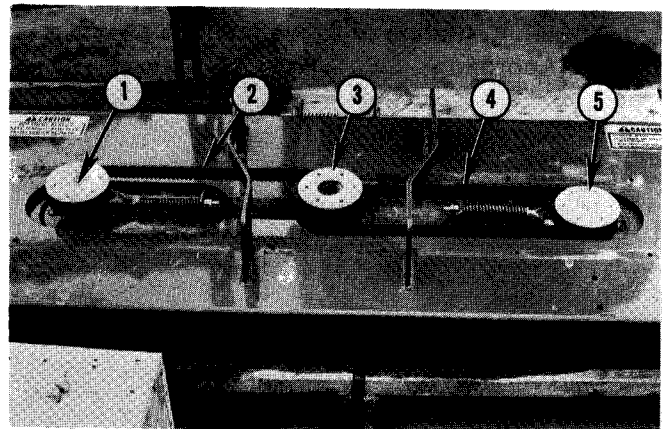

**Fig. 44 — Belt Replacement**

- |                      |                   |
|----------------------|-------------------|
| 1. Left-Hand Pulley  | 3. Center Pulleys |
| 2. Top Belt          | 4. Bottom Belt    |
| 5. Right-Hand Pulley |                   |



underside of housing, remove all rust and touch up bare spots with paint, available in spray cans from your Snapper Dealer.

Check condition of belt and pulleys for damage or excessive wear. Replace if necessary.

Apply a light coat of grease to mower blades and drive line. Apply oil lightly to all pivot points on mower linkage.

Place mower where it will not come in contact with excessive moisture.

## REMOVING MOWER FROM STORAGE

Sharpen blades if necessary.

Check bolts on cutting blades for proper tightness.

Check lubrication points and wipe off excess oil or grease.

Check all nuts on attaching parts on Tractor for proper tightness.

## MOWER SPECIFICATIONS

### 42" MOWER

Blades — Three .....	14-1/2 inches
Overlap .....	3/4 inch
Cutting Width .....	42 inches
Cutting Height (Range of Adjustment) .....	1-1/2" to 4"
Weight (Approx.) .....	150 lbs.

### 48" MOWER

Blades — Three .....	16-1/2 inches
Overlap .....	3/4 inch
Cutting Width .....	48 inches
Cutting Height (Range of Adjustment) .....	1-1/2" to 4"
Weight (Approx.) .....	175 lbs.

# FACTORY RECOMMENDED

## NEW TRACTOR PRE-DELIVERY INSPECTION CHECK LIST

Date \_\_\_\_\_

Customer: \_\_\_\_\_ Address \_\_\_\_\_

Tractor Model \_\_\_\_\_ Serial No. \_\_\_\_\_ Engine No. \_\_\_\_\_

**THIS PRE-DELIVERY INSPECTION CHECK LIST IS PROVIDED TO IDENTIFY THE ITEMS CHECKED AND IF NECESSARY ADJUSTED BY THE DEALER PRIOR TO DELIVERY OF THIS MACHINE.**

INSPECT THE FOLLOWING AND ADJUST IF NECESSARY

### ENGINE

- |  |   |
|--|---|
| <ul style="list-style-type: none"><li><input type="checkbox"/> Engine Oil Level</li><li><input type="checkbox"/> All oil drain plugs</li><li><input type="checkbox"/> Fuel line connections</li><li><input type="checkbox"/> Service air filter</li><li><input type="checkbox"/> Electrical connections</li><li><input type="checkbox"/> Choke control</li><li><input type="checkbox"/> Throttle control</li></ul> | <ul style="list-style-type: none"><li><input type="checkbox"/> Activate battery</li><li><input type="checkbox"/> Alternator charging</li><li><input type="checkbox"/> Engine RPM (idle)</li><li><input type="checkbox"/> Engine RPM (full throttle)</li><li><input type="checkbox"/> Carburetor adjustment</li><li><input type="checkbox"/> Governor performance</li><li><input type="checkbox"/> Safety Switch Operation</li></ul> |
|--|---|

### CHASSIS

- |   |   |
|---|---|
| <ul style="list-style-type: none"><li><input type="checkbox"/> Transaxle oil level</li><li><input type="checkbox"/> Lubricate fittings</li><li><input type="checkbox"/> Clutch-brake adjustment</li><li><input type="checkbox"/> Steering gear</li><li><input type="checkbox"/> Mower level</li></ul> | <ul style="list-style-type: none"><li><input type="checkbox"/> Mower blade timing</li><li><input type="checkbox"/> Torque all chassis bolts</li><li><input type="checkbox"/> Wheel bolts (rear)</li><li><input type="checkbox"/> Tire pressure</li><li><input type="checkbox"/> Drive test</li><li><input type="checkbox"/> Is Operator's Manual with Tractor</li></ul> |
|---|---|

INSPECTION PERFORMED BY: \_\_\_\_\_

Signature \_\_\_\_\_

### Explain the following to the owner

- |  |   |
|--|---|
| <ul style="list-style-type: none"><li><input type="checkbox"/> Instruments and Controls</li><li><input type="checkbox"/> Wheel tread adjustment</li><li><input type="checkbox"/> Operating procedures</li><li><input type="checkbox"/> Lubrication</li></ul> | <ul style="list-style-type: none"><li><input type="checkbox"/> Air filter service</li><li><input type="checkbox"/> Tire and battery care</li><li><input type="checkbox"/> Storage</li><li><input type="checkbox"/> Operator's Manual</li><li><input type="checkbox"/> Safety Instructions</li></ul> |
|--|---|

**FACTORY RECOMMENDED**  
**NEW TRACTOR PRE-DELIVERY INSPECTION CHECK LIST**

Date \_\_\_\_\_

Customer: \_\_\_\_\_ Address \_\_\_\_\_

Tractor Model \_\_\_\_\_ Serial No. \_\_\_\_\_ Engine No. \_\_\_\_\_

**THIS PRE-DELIVERY INSPECTION CHECK LIST IS PROVIDED TO IDENTIFY THE ITEMS CHECKED  
AND IF NECESSARY ADJUSTED BY THE DEALER PRIOR TO DELIVERY OF THIS MACHINE.**

INSPECT THE FOLLOWING AND ADJUST IF NECESSARY

**ENGINE**

- |   |   |
|---|---|
| <input type="checkbox"/> Engine Oil Level       | <input type="checkbox"/> Activate battery           |
| <input type="checkbox"/> All oil drain plugs    | <input type="checkbox"/> Alternator charging        |
| <input type="checkbox"/> Fuel line connections  | <input type="checkbox"/> Engine RPM (idle)          |
| <input type="checkbox"/> Service air filter     | <input type="checkbox"/> Engine RPM (full throttle) |
| <input type="checkbox"/> Electrical connections | <input type="checkbox"/> Carburetor adjustment      |
| <input type="checkbox"/> Choke control          | <input type="checkbox"/> Governor performance       |
| <input type="checkbox"/> Throttle control       | <input type="checkbox"/> Safety Switch Operation    |

**CHASSIS**

- |  |  |
|--|--|
| <input type="checkbox"/> Transaxle oil level     | <input type="checkbox"/> Mower blade timing                |
| <input type="checkbox"/> Lubricate fittings      | <input type="checkbox"/> Torque all chassis bolts          |
| <input type="checkbox"/> Clutch-brake adjustment | <input type="checkbox"/> Wheel bolts (rear)                |
| <input type="checkbox"/> Steering gear           | <input type="checkbox"/> Tire pressure                     |
| <input type="checkbox"/> Mower level             | <input type="checkbox"/> Drive test                        |
|  | <input type="checkbox"/> Is Operator's Manual with Tractor |

**INSPECTION PERFORMED BY:** \_\_\_\_\_

Signature \_\_\_\_\_

**Explain the following to the owner**

- |   |  |
|---|--|
| <input type="checkbox"/> Instruments and Controls | <input type="checkbox"/> Air filter service    |
| <input type="checkbox"/> Wheel tread adjustment   | <input type="checkbox"/> Tire and battery care |
| <input type="checkbox"/> Operating procedures     | <input type="checkbox"/> Storage               |
| <input type="checkbox"/> Lubrication              | <input type="checkbox"/> Operator's Manual     |
|   | <input type="checkbox"/> Safety Instructions   |

**Dealer Copy**

## MANUFACTURER'S 90 DAY LIMITED WARRANTY

For ninety (90) days from purchase date for a non-commercial user, or for **Thirty (30) days from purchase date for a commercial user**, McDONOUGH POWER EQUIPMENT, through any factory authorized service dealer, will replace for the original purchaser, free of charge, any part or parts found upon examination by the factory at McDonough, Georgia, to be defective in material or workmanship or both.

All transportation cost incurred by the purchaser in submitting material to an authorized service dealer for replacement under this warranty must be borne by the purchaser.

This warranty does not apply to engines or transmissions and their components, as these items are warranted separately by their manufacturers. Neither does it apply to parts that have been damaged by accident, alteration, abuse, improper lubrication, normal wear, or other cause beyond our control.

There is no other express warranty.

Implied warranties, including those of merchantability and fitness for a particular purpose, are limited to ninety (90) days from purchase for non-commercial users, and for thirty (30) days from purchase for commercial users and to the extent permitted by law any and all implied warranties are excluded. This is the exclusive remedy. Liabilities for consequential damages under any and all warranties are excluded.

Some states do not allow limitations on how long an implied warranty lasts or do not allow the exclusion or limitations of incidental or consequential damages, so the above limitation or exclusion may not apply to you.

This warranty gives you specific legal rights, and you may also have other rights which vary from state to state.

**WARNING: Use of replacement parts other than genuine SNAPPER parts may impair the safety of your tractor.**

**IMPORTANT:** Please fill out the attached Snapper Guarantee Card and mail to:

**McDONOUGH POWER EQUIPMENT, McDONOUGH, GEORGIA 30253**

IT IS THE POLICY OF McDONOUGH POWER EQUIPMENT TO IMPROVE ITS PRODUCTS WHENEVER IT IS POSSIBLE AND PRACTICAL TO DO SO. WE RESERVE THE RIGHT TO MAKE CHANGES OR ADD IMPROVEMENTS AT ANY TIME WITHOUT INCURRING ANY OBLIGATION TO MAKE SUCH CHANGES ON PRODUCTS MANUFACTURED PREVIOUSLY.



## Free Manuals Download Website

<http://myh66.com>

<http://usermanuals.us>

<http://www.somanuals.com>

<http://www.4manuals.cc>

<http://www.manual-lib.com>

<http://www.404manual.com>

<http://www.luxmanual.com>

<http://aubethermostatmanual.com>

Golf course search by state

<http://golfingnear.com>

Email search by domain

<http://emailbydomain.com>

Auto manuals search

<http://auto.somanuals.com>

TV manuals search

<http://tv.somanuals.com>