

Rear Power Take Off

MFG. NO. 1600315

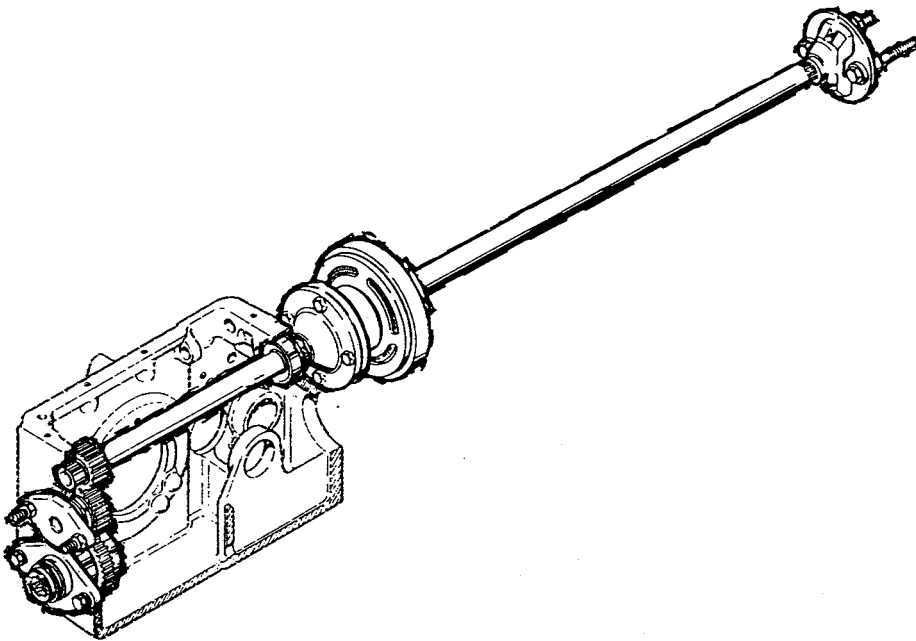

OPERATOR'S MANUAL

FORM - 1651579
PRINTED IN U.S.A.
7411

ASSEMBLY INSTRUCTION w/PARTS LIST

TABLE OF CONTENTS

Paragraph	Description	Page
A	Rear PTO Installation	1
B	Rear PTO Breakdown (w/Parts List and Exploded View)	2,3
C	Part Availability and Cleaning	4
D	Three-Point Hitch Removal	4
E	Tractor Component Removal	4
F	Final Drive Installation	5
G	Drive Unit Installation	5
H	Rear PTO Clutch Switch and Jumper Wire Installation	9
I	Tractor Components Installation	9
J	Three-Point Hitch Installation	10

A. REAR PTO INSTALLATION

Installation of the rear PTO is accomplished by installing a final drive unit in the transmission and a drive unit from the transmission to the engine pulleys. Refer to Figure 1 for both installations.

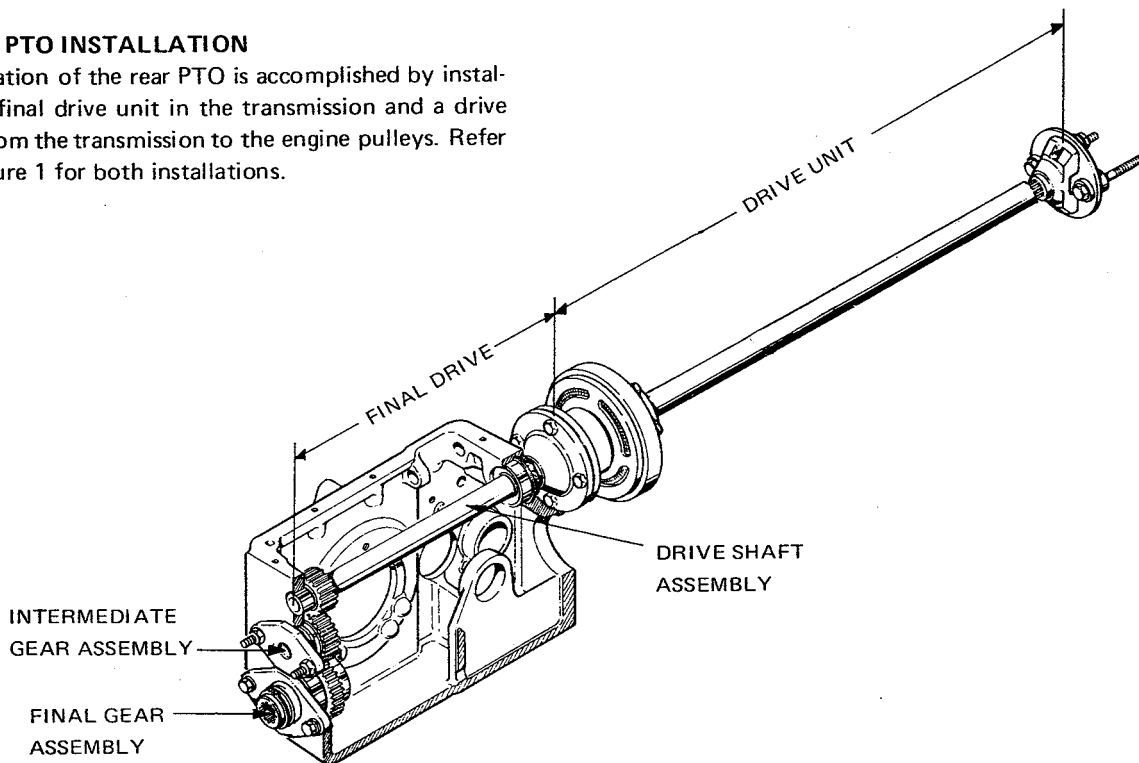

Figure 1. Rear PTO Installation

B. REAR PTO BREAKDOWN

1. Final Drive Unit

The rear PTO final drive consists of three major assemblies: they are (a) drive shaft, (b) intermediate gear, and (c) final gear.

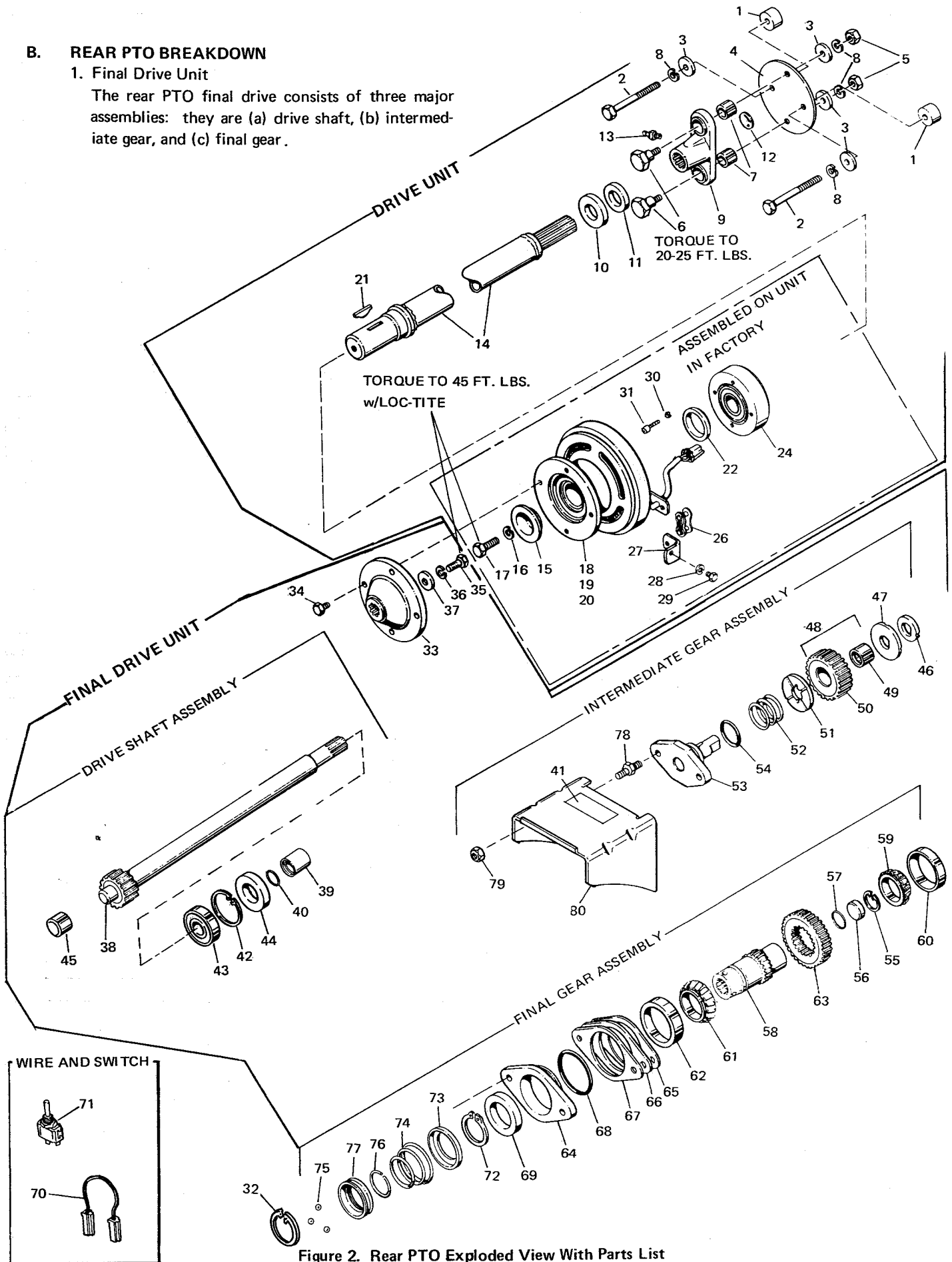

Figure 2. Rear PTO Exploded View With Parts List

Ref. No.	Qty.	Description
1	2	SPACER
2	2	CAPSCREW, Hex,
3	4	WASHER, Special
4	1	COUPLING
5	2	NUT, hex ham, 3/8-16
6	2	BOLT, Shoulder
7	2	BUSHING
8	4	LOCKWASHER, 3/8
9	1	YOKE
10	1	WASHER
11	1	WASHER, Felt
12	1	PLUG
13	1	FITTING, Grease
14	1	SHAFT ASSEMBLY
15	1	COLLAR
16	1	LOCKWASHER, 3/8
17	1	CAPSCREW, hex, 3/8-16 x 1-1/4
18	1	CLUTCH, Electric
19	1	FIELD ASSEMBLY
20	1	ROTOR ARMATURE ASSY.
21	1	KEY
22	1	WASHER
24	1	BEARING ASSEMBLY
26	1	LINK, Connector
27	1	BRACKET ASSEMBLY
28	1	LOCKWASHER, 1/4
29	1	CAPSCREW, Hex, 1/4-20 x 3/4
30	4	LOCKWASHER No. 10
31	4	SCREW, Socket Head, No.10- 32 x 1/2
32	1	RING, Retaining
33	1	HUB
34	4	CAPSCREW, Hex, 5/16-18 x 1
35	1	CAPSCREW, Hex, 3/8-16 x 1
36	1	LOCKWASHER, 3/8
37	1	WASHER, Special
38	1	PTO SHAFT ASSEMBLY
39	1	SPACER
40	1	"O" RING
41	1	FILM, Safety

Ref. No.	Qty.	Description
42	1	RING, Retaining
43	1	BEARING, Ball
44	1	SEAL, Brake
45	1	BEARING
46	1	WASHER
47	1	WASHER, Thrust
48	1	GEAR ASSEMBLY
49		(includes ref. nos. 49 & 50)
49	1	BEARING
50	1	GEAR
51	1	WASHER, Thrust
52	1	SPRING
53	1	CAP ASSEMBLY
54	1	"O" RING
55	1	RING, Retaining
56	1	PLUG
57	1	"O" RING
58	1	GEAR, Drive
59	1	CONE, Bearing
60	1	CUP, Bearing
61	1	CONE, Bearing
62	1	CUP, Bearing
63	1	GEAR
64	1	CAP
65	3	SHIM, .002
66	3	SHIM, .010
67	3	SHIM, .003
68	1	"O" RING
69	1	SEAL
70	1	WIRE, Jumper
71	1	SWITCH, Electric
72	1	RING, Retaining
73	1	RETAINER
74	1	SPRING
75	3	BALL
76	1	RETAINER, Spring
77	1	COLLAR
78	2	STUD
79	2	NUT, Full hex, 3/8-16
80	1	SHIELD

2. Drive Unit

Major components of the drive unit are a coupling, keyed shaft, electric clutch, and hub.

C. PARTS AVAILABILITY AND CLEANING

Before installing the rear PTO on the tractor, check to see if all parts listed with Figure 2 are available. Clean all parts prior to installation with clean rags and solvent. Bearings should soak long enough in solvent to remove any grease or dirt, dried thoroughly, and lubricated lightly with Type A or Dexron automatic transmission fluid.

D. THREE-POINT HITCH REMOVAL (FIGURE 3)

NOTE

If three-point hitch is not on tractor, refer to Mfg. No. 735 Assembly Instructions when PTO installation is complete

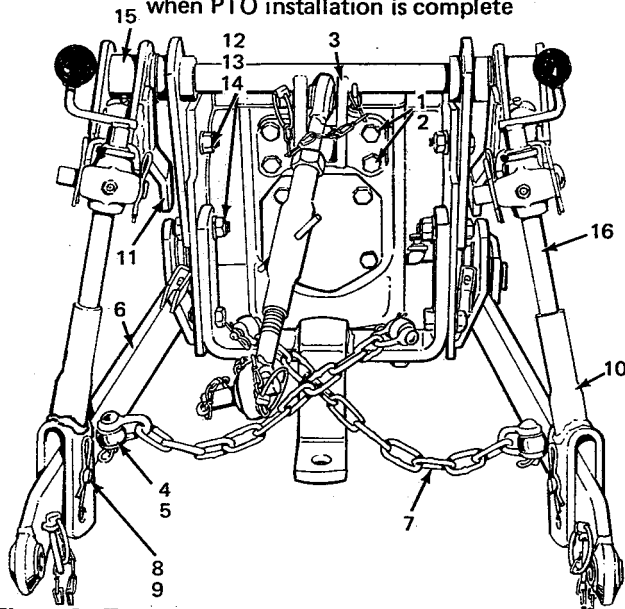

Figure 3. Three-Point Hitch Removal and Installation

Ref. No.	Qty.	Description
1	4	Capscrew
2	4	Lockwasher
3	1	Turnbuckle Link Assembly
4	2	Hairpin Clip
5	2	Pin
6	2	Pull Link Assembly
7	2	Chain
8	2	Hairpin Clip
9	2	Pin
10	2	Clevis Assembly
11	1	Left Lift Arm
12	4	Nut
13	4	Lockwasher
14	4	Capscrew
15	2	Lift Arm Assembly
16	2	Link Assembly

1. Refer to applicable attachment owners manual and remove attachment from three-point hitch.
2. Remove four capscrews (1) and lockwashers (2) mounting turnbuckle link assembly (3) to transmission case.

3. Remove four nuts (12) lockwashers (13) and capscrews (14) attaching lift arm assemblies (15) to tractor and remove lift arm assemblies with link assemblies (16) from tractor.

E. TRACTOR COMPONENT REMOVAL

1. Raise tractor hood and disconnect negative terminal battery cable.
2. Remove four capscrews and lockwashers attaching seat support to differential case cover. Remove seat and support.
3. Remove six washer-head screws attaching top cover to frame. Remove top cover.
4. Remove capscrew and locknut securing steering wheel to shaft. Turn and pull steering wheel until it is worked free of shaft.
5. Remove three thread-forming screws and a speed clip attaching clutch lever panel assembly. Remove panel assembly. (Left hand panel only).
6. Remove six thread-forming screws attaching instrument panel to support.
7. Being careful not to break electrical wires and connections, lift instrument panel up and out from support.
8. Remove one thread-forming screw and three washers attaching left side of oil cooler to frame. Carefully bend back oil cooler.

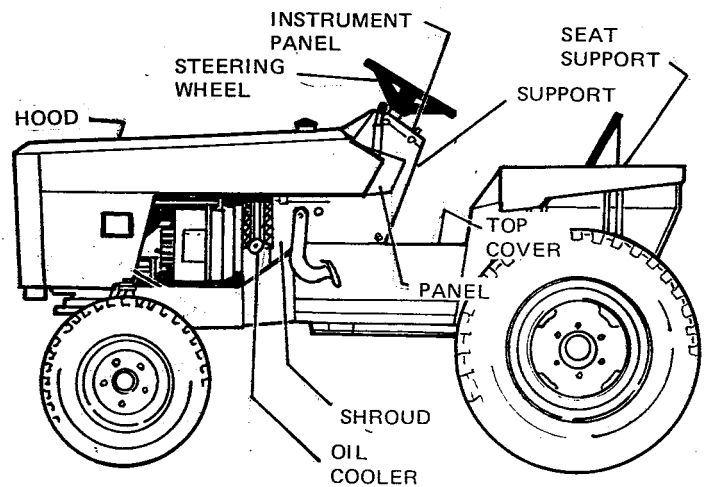

Figure 4. Tractor Components

F. FINAL DRIVE INSTALLATION

1. Raise rear end of tractor approximately six inches and block in this position. This will allow PTO installation into transmission without draining oil.
2. On 4041 tractor, remove dip stick from differential case cover. Remove five capscrews attaching differential case cover. Remove cover and gasket.

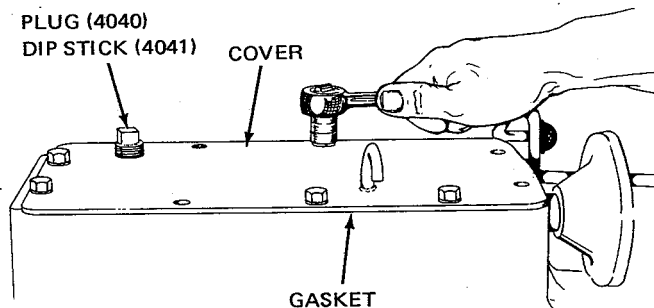

Figure 5. Transmission Top Cover

3. Remove four capscrews and lockwashers attaching transmission rear cover to case. Remove rear cover and gasket. Clean gasket area using caution not to get gasket material in transmission case.

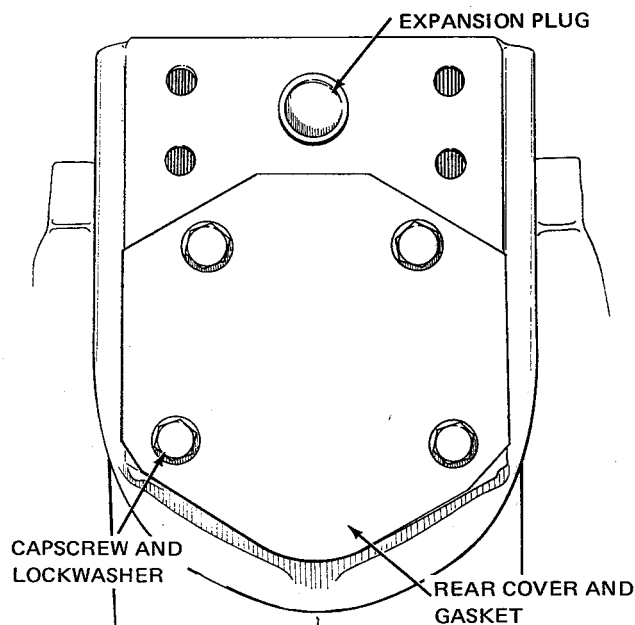

Figure 6. Transmission Rear Cover

4. Final Gear Assembly Installation

- a. Using a long wooden block and hammer, carefully and evenly tap clean inner bearing cup in large partition hole of transmission case (Figure 7). Install bearing cone in inner bearing cup.

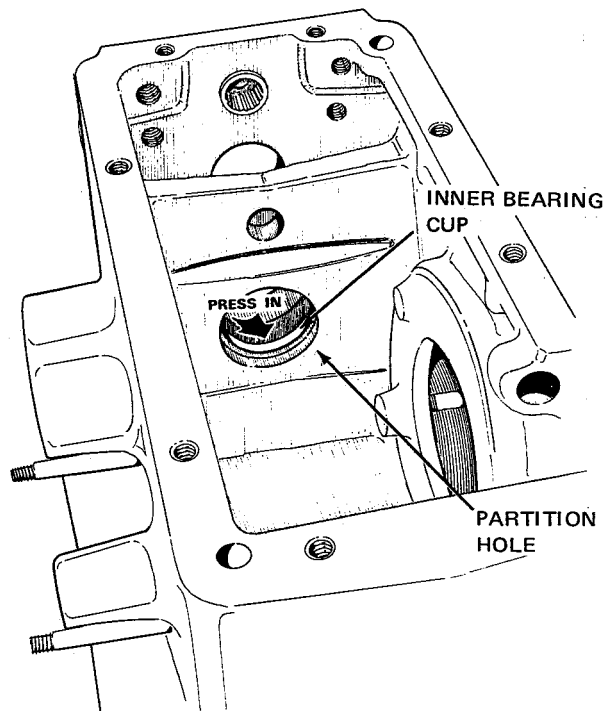

Figure 7. Final Gear Inner Bearing Installation

- b. Using block of wood and hammer, carefully and evenly tap outer bearing cone on final gear assembly shaft, bringing it up flush against side of gear teeth (Figure 8).

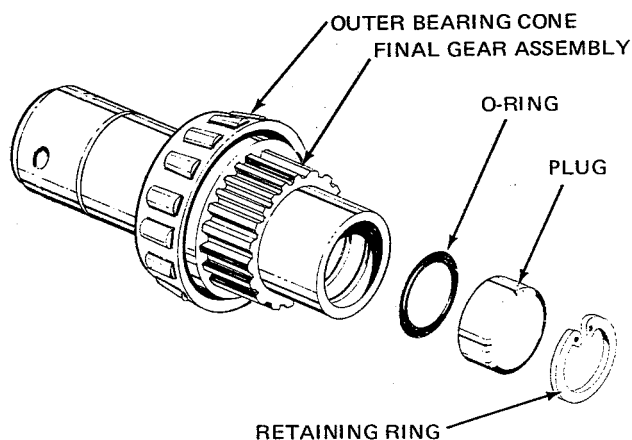

Figure 8. Final Gear Plug Installation

- c. Install O-ring, plug, and retaining ring in final gear assembly shaft (Figure 8).
- d. Holding 36-tooth gear in place, insert final gear assembly through large hole on outer wall of transmission case (Figure 9), through gear, and into inner bearing cone.

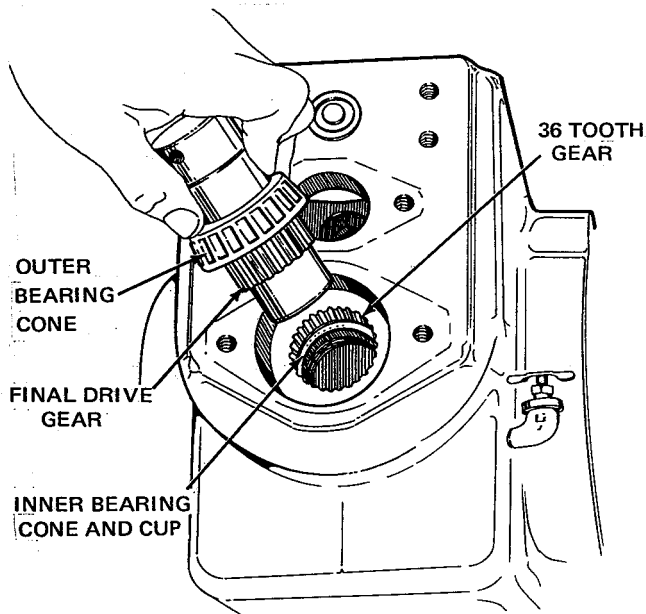

Figure 9. Final Drive Gear Installation

- e. Using a wooden block and hammer carefully and evenly tap the bearing cup into the large hole on the outer wall of the transmission case until it is snug against installed outer bearing cone. Be sure large diameter of cup faces toward bearing.
- f. Install O-ring on cap and, using two capscrews and lockwashers removed when removing transmission rear cover, torque cap to case at 30 foot pounds.
- g. The cap should now be flush against outer bearing cup. It is necessary, however, to have 0.002 to 0.005 inch end-play between the cap and the outer bearing cup. Refer to Figure 10 for dimension required.

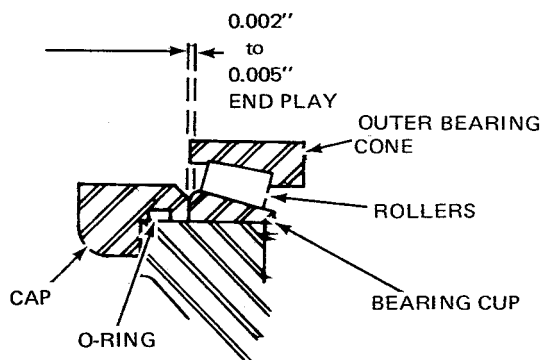

Figure 10. Final Gear Assembly Cap End Play

- h. To establish required end-play in, insert a tapered feeler gauge (Figure 11) in between tightened cap and transmission case. Any type feeler gauge may be used, however, a

tapered feeler gauge is recommended. The reading obtained on gauge plus 0.010 inch is the shimming required to obtain 0.002 to 0.005 end-play.

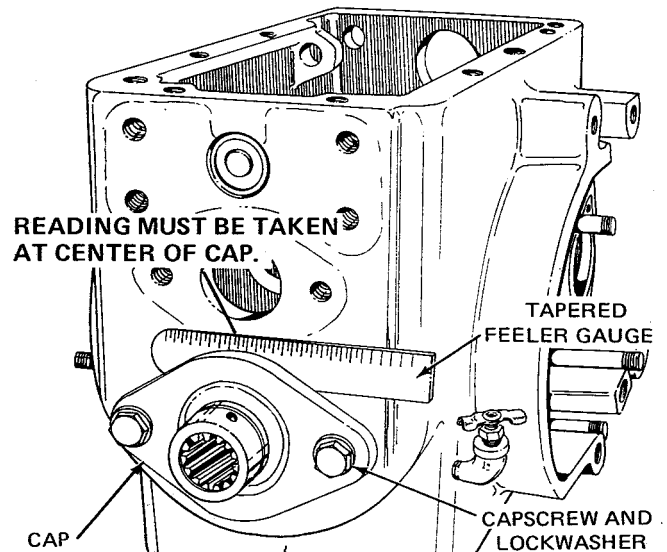

Figure 11. Final Gear Assembly Shimming Measurement

- i. Remove cap and install required shimming and seal in cap. Red shim is 0.002 inch, green shim 0.003 inch, and rust shim 0.010 inch. Torque cap again to 30 foot pounds.
- j. Set up dial indicator on end of gear assembly shaft and manually push and pull shaft. Indicator reading should be between 0.002 to 0.005 inch. If reading is not as specified, reshim per (step i) above.
- k. Using Tru-arc pliers, install retaining ring on final gear assembly shaft (Figure 12). Install retainer and spring on shaft, large coil of spring in concave side of retainer.
- l. Place a dab of grease on each of the three balls and place balls in shaft holes. Compress spring retainer in collar and press collar, retainer on inside, against spring until balls pass over spring retainer and collar is locked in position.
- j. Install Retaining Ring.

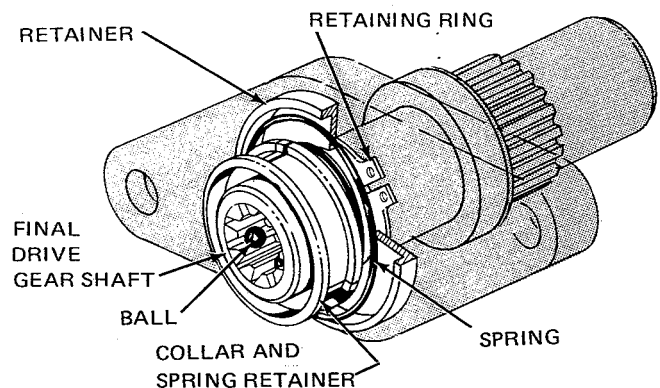

Figure 12. Locking Collar Installation

5. Intermediate Gear Assembly Installation (Figure 13).

- a. Grease metal washer and place it over small partition hole notch up and flat inside diameter to right.

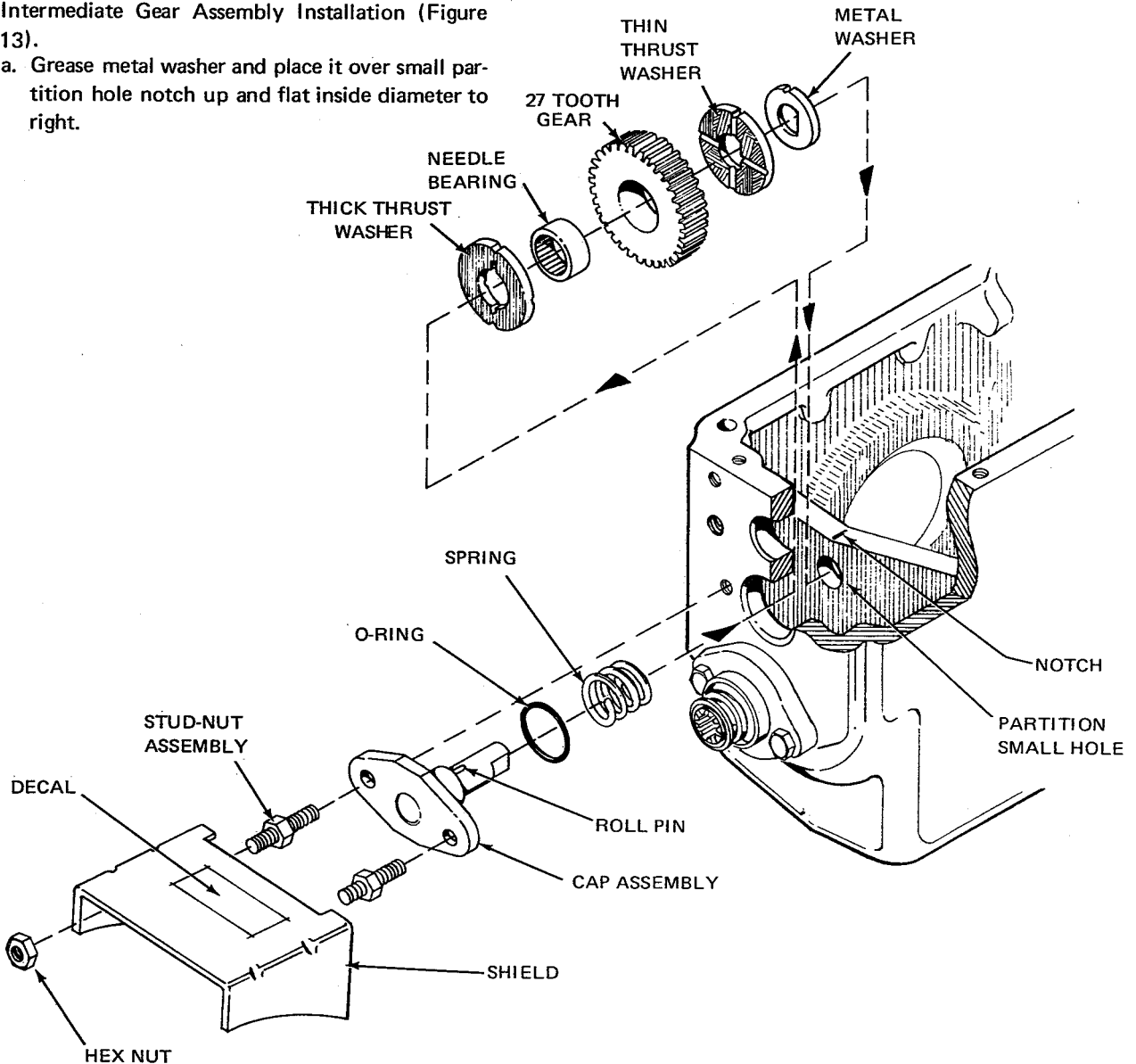

Figure 13. Intermediate Gear Installation

- b. Install O-ring in cap and insert cap, (roll pins installed) into transmission case.
- c. Install two stud-nut assemblies, O-ring, and spring on cap assembly. Be sure both roll pins are inserted completely into cap assembly.
- d. Assure that needle bearing is clean, lightly lubricated with Type A or Dexron automatic transmission oil and securely pressed into 27 tooth gear.
- e. Assemble thick and thin thrust washers and gear assembly as shown in Figure 13 between partition and transmission case wall, aligning washer and gear holes. Be sure thrust washers have notches up, grooves facing gear assembly and that thick thrust washer is to the outside next to spring.

NOTE

Thrust washers and metal washer notches must be aligned with notch on partition.

- f. Using caution not to damage roll pins, insert cap assembly (Flat side of shaft to right) through transmission case middle hole, thrust washer and gear alignment, metal washer, and partition hole. Compress spring as required to loosely secure cap to case with stud-nut assemblies.
- g. Torque cap to case at 30 foot pounds.
- h. Apply decal to shield and secure shield to stud-nut assemblies with two hex nuts.

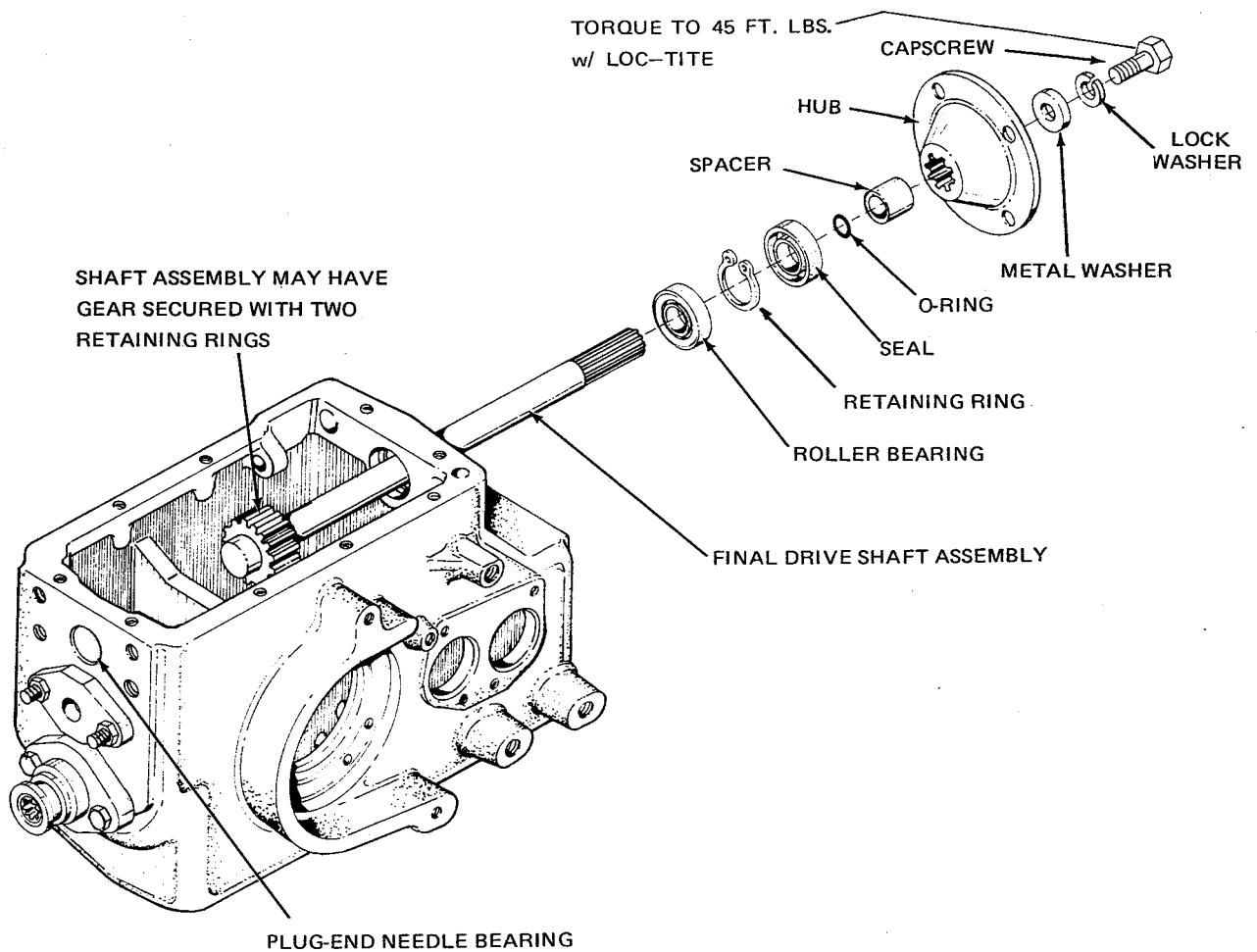

Figure 14. Final Drive Shaft Installation

6. Drive Shaft Assembly Installation (Figure 14).

- a. Remove expansion plugs from top holes in transmission case. Press plug-end needle bearing into position (plug-end facing out) in top hole of transmission, final drive unit end.
- b. On some early production models, the 20 tooth gear is to be installed on drive shaft and secured with two retaining rings. Be sure concave side of gear faces installed plug-end needle bearing.
- c. Install roller bearing on shaft against shaft shoulder and press it firmly against case shoulder at the same time guiding the other end of the shaft into the installed needle bearing. Using a

Tru-arc pliers, install retaining ring in groove forward of roller bearing.

- d. Install O-ring in spacer and firmly seat spacer on shaft against bearing. Install seal against retaining ring.
 - e. Install hub on shaft and secure it with a metal washer, lockwasher, and cap screw. Apply Loc-tite to cap screw and torque to 45 foot pounds.
7. Secure differential case cover and new gasket to case with five cap screws. Install dipstick in case cover on 4041 tractor or plug on 4040 tractor.
 8. Remove blocks from under rear of tractor and lower tractor to ground.

G. DRIVE UNIT INSTALLATION

1. Electric clutch is assembled on the drive shaft at the factory and should be checked only for tightness and freedom of movement. Capscrew attaching collar to shaft should be torqued to 45 foot pounds.
2. Install grease fitting (13, Figure 2), and plug (12) in position on yoke (9).
3. Slide rubber washer (10, Figure 2) felt washer (11) and yoke (9) on shaft (14). Attach coupling (4) to yoke with two capscrews (6), lockwashers (8), flat washers (3), and nuts (5).
4. Place drive unit, clutch to rear, in tractor.
5. Block clutch (Figure 15) or hub with large wrench or crowbar, and secure clutch to hub with four self-tapping screws.

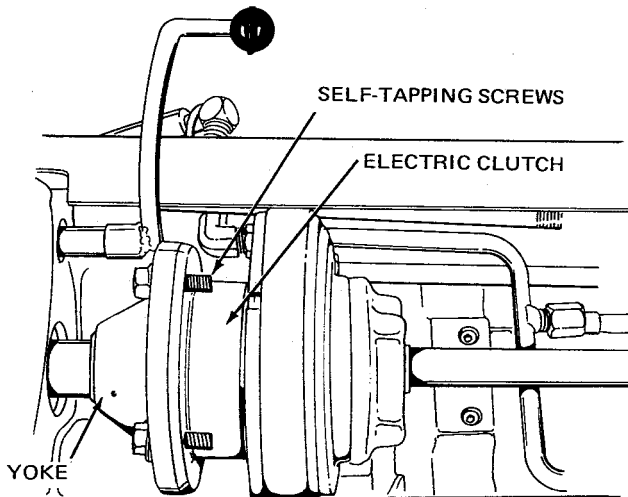

Figure 15. Drive Shaft Clutch Installation

6. Secure clutch bracket (27, Figure 2) with capscrew (29) and lockwasher (28). Make clutch electrical connection.

NOTE

See paragraph H for rear PTO switch and jumper installation.

7. Loosely attach coupling (Figure 16) to flywheel through upper input pulley with two 3/8-16 x 3-1/2* inch capscrews, washers, and spacers. Apply Loctite to capscrews before installation.
8. Using a dial indicator, check shaft (Figure 16) for runout of no more than 0.025 of an inch at location indicated in Figure 16.

* Use Screw 3-1/2 inch long for 19-1/2 h.p. tractor, and a screw 3-1/4 inch long for 16-1/2 h.p. tractor.

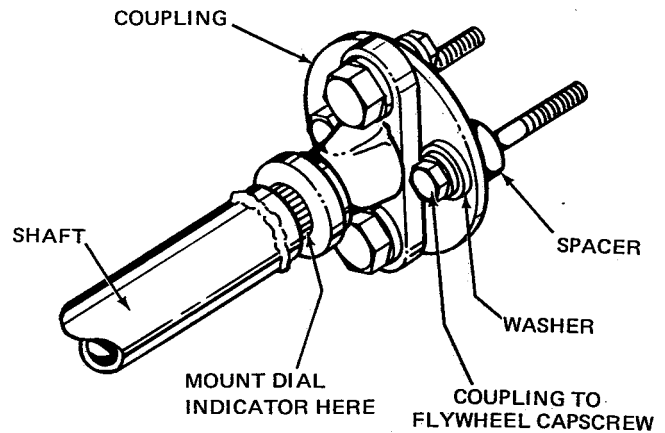

Figure 16. Rear PTO Coupling Installation

9. If runout exceeds 0.025 of an inch, reposition shaft by tapping shaft until runout falls below 0.025.
10. Torque coupling to flywheel capscrows at 25-30 foot pounds.

CAUTION

Torquing over 30 foot pounds may strip threads in flywheel.

11. Lubricate shaft through yoke grease fitting (13, Figure 2) with general purpose automotive grease. Be sure plug is in place in yoke.

H. REAR PTO CLUTCH SWITCH AND JUMPER WIRE INSTALLATION

1. Install rear clutch switch in mounting hole below front clutch switch.

NOTE

Figure 17 shows clutch switches as they appear when instrument panel tilted bottom up. The front clutch switch is normally above rear clutch switch when panel is installed in operating position.

2. Move green wire from post 7 on front clutch switch to post 4 on rear clutch switch.
3. Move purple wire from post 8 on front clutch switch to post 7 on same front clutch switch.
4. Install black jumper wire on post 3 of rear clutch switch and post 8 of front clutch switch.
5. Check double connector on front clutch switch for secure installation on posts 5 and 6.
6. Install the two blue/white wire double connector found loose along steering shaft on posts 1 and 2 of rear clutch switch.

I. TRACTOR COMPONENT INSTALLATION Figure 4.

NOTE

Before installing tractor components and three-point hitch, inspect entire rear PTO for proper installation.

1. Secure upper rear shroud to right and left hand shrouds with two 3/8 inch long thread forming screws.
2. Carefully bend back oil cooler and secure it to frame with three washers and a 1-1/2 inch long thread forming screws.
3. Install instrument panel support against frame support and secure with 3/8 inch long thread forming screws. Install parking brake handle knob.
4. Being careful not to break electrical wire and connections, install instrument panel on support and secure it with six 3/8 inch long thread forming screws.
5. Install choke cable and three clips. On 4040 tractor, install air cleaner.
6. Secure clutch lever panel assembly to instrument panel support with three 3/8 inch long thread forming screws and a speed clip.
7. Install fuel tank on tractor. Press open two fuel line clamps and install fuel lines on tank. Bend fuel

tank straps back and secure both straps to frame with a one inch long thread forming screw.

8. Install steering wheel on shaft and secure it to shaft with a 1-1/4 inch long capscrew and lock nut.

J. THREE-POINT HITCH INSTALLATION (FIGURE 3)

1. Secure lift arm assemblies (15) with link assemblies (16) to tractor with four nuts (12), lockwashers (13), and capscrews (14).
2. Attach cylinder rod end to left lift arm (11) with spring clip and pin.
3. Attach link assemblies (6) to clevis assemblies (10) with hairpin clip (8) and pin (9).
4. Attach chains (7) to both pull link assemblies (6) with hairpin clips (4) and pins (5).
5. Being careful not to damage PTO shield, secure turnbuckle link assembly (3) to transmission case with four capscrews (1) and lockwashers (2).
6. If attachment connected to three-point hitch, refer to applicable owners manual for installation.

NOTE

Refer to Mfg. No. 735 Assembly Instructions for installation of new three-point hitch if not previously installed.

Free Manuals Download Website

<http://myh66.com>

<http://usermanuals.us>

<http://www.somanuals.com>

<http://www.4manuals.cc>

<http://www.manual-lib.com>

<http://www.404manual.com>

<http://www.luxmanual.com>

<http://aubethermostatmanual.com>

Golf course search by state

<http://golfingnear.com>

Email search by domain

<http://emailbydomain.com>

Auto manuals search

<http://auto.somanuals.com>

TV manuals search

<http://tv.somanuals.com>