

INSTALLATION INSTRUCTIONS

**ELECTRIC CLUTCH FOR
9518 & 5015 DIESEL TRACTORS
MFG. NO. 1690785
REQUIRED FOR 48" MOWER AND
52" SNOWTHROWER INSTALLATION**



WARNING

Before installing kit or making any adjustments make sure engine is stopped, ignition key is removed and parking brake is set.

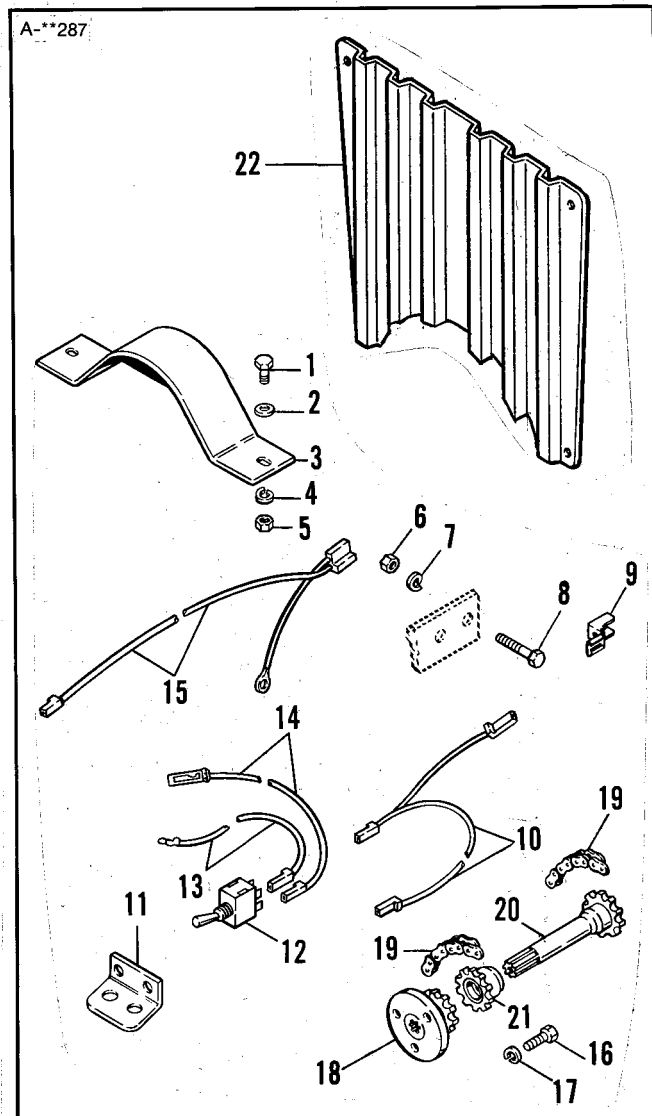

Figure 1.

PREPARATION

1. Remove the grille. Disconnect the battery cables, negative cable first. Remove the battery.
2. Remove the air cleaner. It is not necessary to remove the air intake hose; the assembly can be placed temporarily on top of the engine.
3. Remove the left-hand side panel. Disconnect the support strap at the front and loosen at the rear to swing out of the way for panel removal.
4. Remove the right-hand side panel.
5. Disconnect the 4-pin connector at lower left of grille opening.
6. Remove the grille frame and hood by removing two bolts, nuts and washers at right and left of grille support.
7. Notice that the grille supplied with this kit is notched out for the clutch. The bottom section of the grille frame must be cut off with a hacksaw. Leave 1-1/2" on each side.

ASSEMBLY

1. Lay out the parts shipped with the electric clutch (figure 1). (The electric clutch is not shown).

Item	Description	Qty.
1.	Capscrew, 5/16-18 x 3/4	2
2.	Washer, 5/16	
3.	Clutch Guard	1
4.	Lockwasher, 5/16	2
5.	Nut, 5/16	2
6.	Nut, 7/16	2
7.	Lockwasher, 7/16	4
8.	Capscrew, 7/16-14 x 1	4
9.	2-Way Connector	1
10.	Wire Assembly	1
11.	Switch Bracket	1
12.	Switch	1
13.	Wire	1
14.	Wire	1
15.	Wire	1
16.	Capscrew, M10 x 1-1/4 x 25 mm	3
17.	Lockwasher, 7/16	3
18.	Crankshaft Adaptor	1
19.	Coupling Chain	2
20.	Sprocket and Shaft Assembly	1
21.	Sprocket	1
22.	Grille	1

STANDARD FASTENER IDENTIFICATION CHART

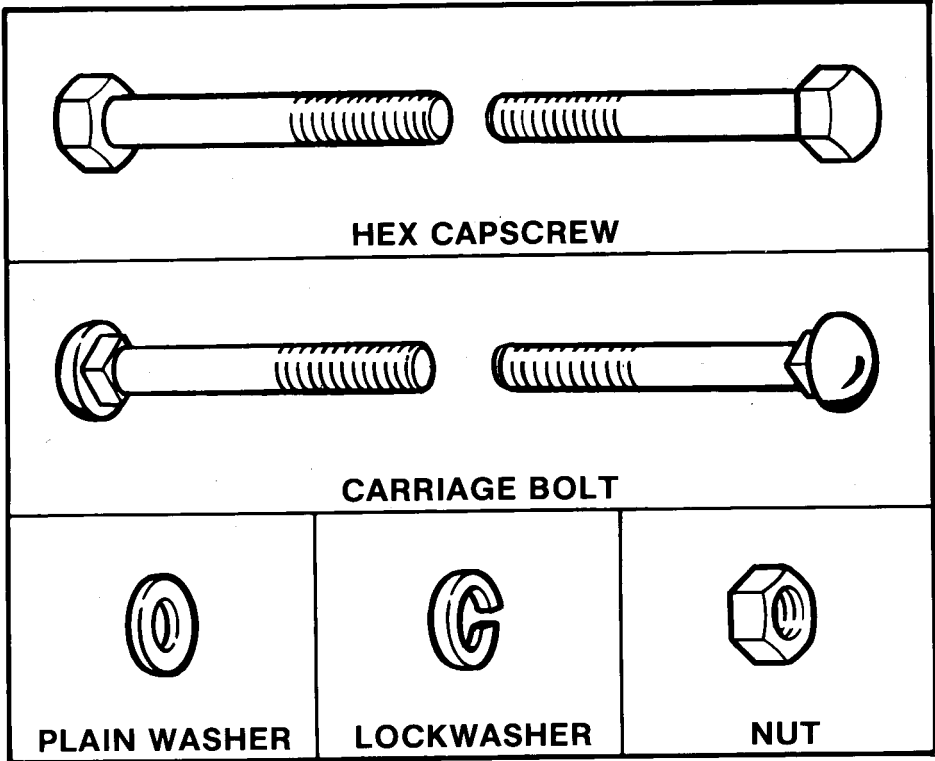

HEX CAPSCREW

CARRIAGE BOLT

PLAIN WASHER

LOCKWASHER

NUT

HEX CAPSCREW IDENTIFICATION

Shown below are actual size hex heads for standard screw sizes. Example: a 1/4" screw has a 7/16 head and thus requires a 7/16 wrench. To measure length, use the scale below.

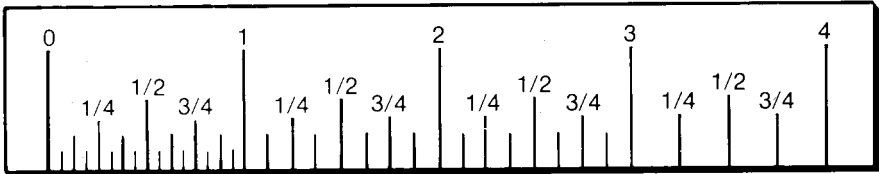
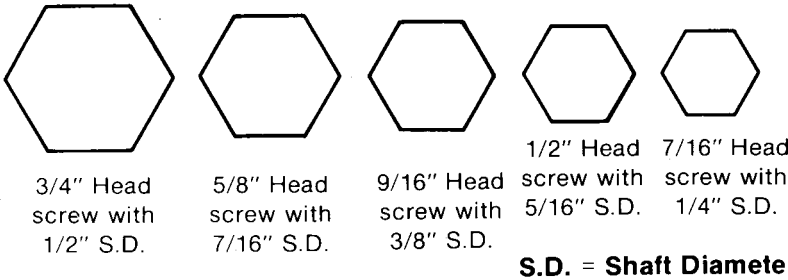

WASHER AND NUT IDENTIFICATION

Place the washer or nut on the above scale to determine the inside diameter. The actual inside diameter can vary 1/16 inch. Use the scale for comparison.

Hardware sizes are given in the illustrations throughout this manual.

If a washer or nut is identified as "washer, 1/2" or "nut, 1/2", this means the inside diameter is 1/2 inch.

If a screw is identified as "screw, 1/2 x 2", this means the shaft diameter is 1/2 inch and the shaft of the screw is 2 inches long. If a screw is identified as "screw, 1/2-16 x 2", the number "16" means that the screw has 16 threads per inch.

SAMPLE: SCREW IDENTIFICATION

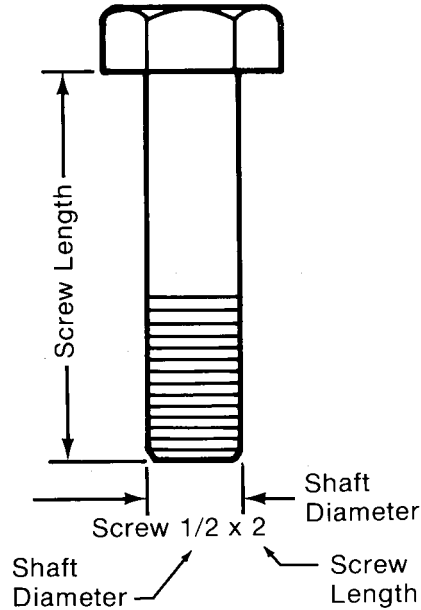

SAMPLE: NUT IDENTIFICATION

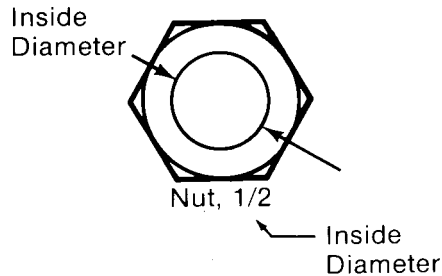

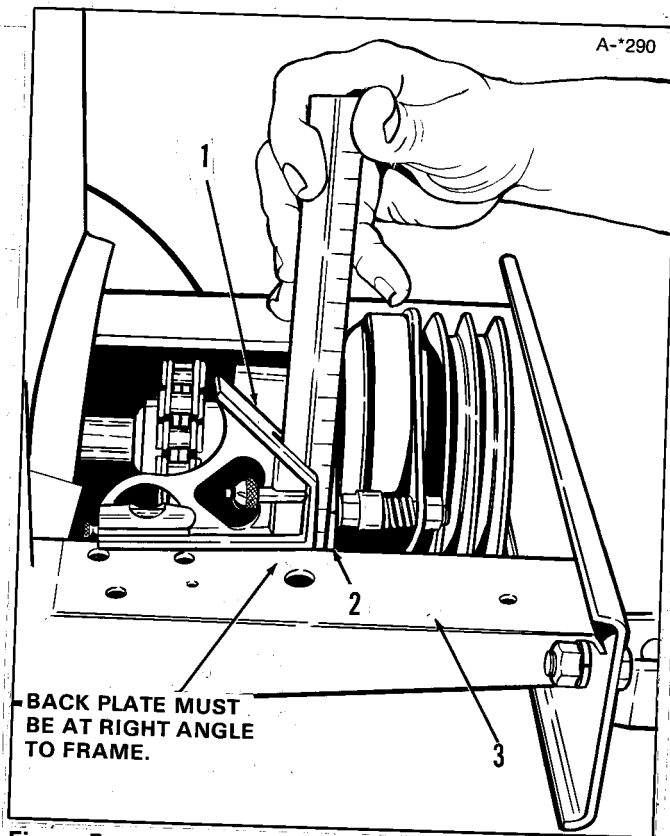

Figure 5.

1. Square 2. Clutch Plate 3. Frame

9. Install switch and wiring as follows.

- a. Attach the wires to the switch terminals as indicated by the letters A thru D in figure 6. To make sure switch is correctly positioned notice the terminal spacing on switch diagram in figure 6.
- b. Remove the two bottom screws from the dash and use these screws to install the switch plate (figure 7).
- c. Route the wire (4, figure 6) behind the steering post, over to the fuse box. If a wire is connected to bottom terminal, disconnect it and install 2-way connector. Connect both wires to connector. Remove the bottom fuse from fuse box. Install the 20 amp fuse supplied with kit in its place.
- d. Route the two wires (5, figure 6), following the tachometer cables, to the interlock switch in front of left-hand pedal.
- e. Disconnect either of the two black wires at the switch by pulling apart at terminal. Connect the two wires just routed from switch to the two terminals that are now open. (You are connecting the switch in-line with interlock switch). Apply tape as necessary.

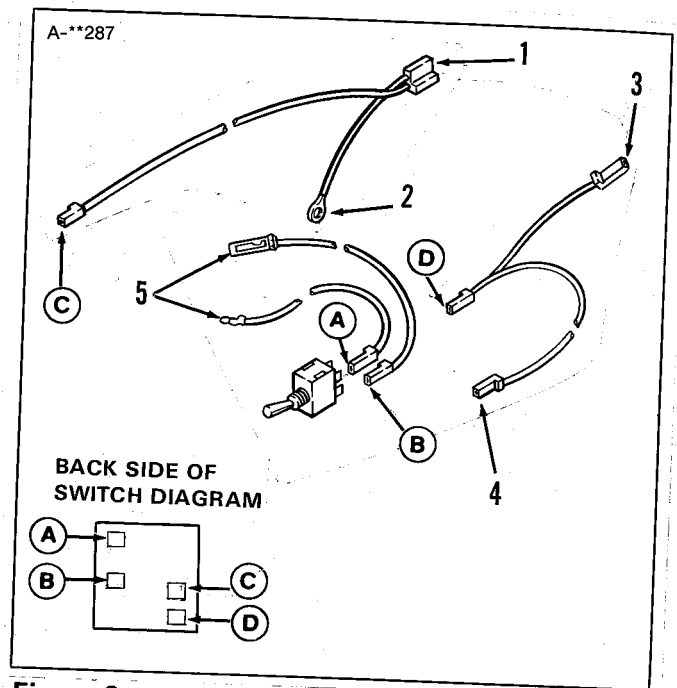

Figure 6.

1. To plug at clutch
2. To ground at battery negative cable
3. To spout rotator switch (if used)
4. To bottom terminal of fuse box (use 2-way connector)
5. To interlock at left foot pedal

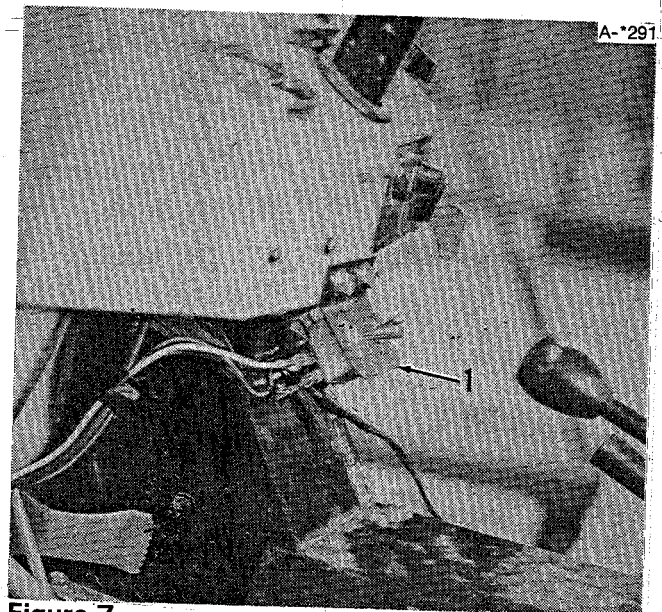

Figure 7.

1. Switch Plate

NOTE

Check if the wire connection on the clutch is on the right-hand or left-hand side. In step "F" route the wire on appropriate side of tractor.

- f. Route the longest wire (1, figure 6) to front of tractor, following the wiring harness. Connect the plug to the plug at the clutch.
- g. Connect the ground wire (2, figure 6) with same capscrew used to secure battery negative cable to frame, if wire was routed on left-side of tractor. If on right-hand side, connect ground wire to frame with a 1/4-20 capscrew, washer and nut (obtain locally).
- h. Tape the wires just installed to the tachometer cable, as necessary to keep wires away from moving parts.

- 10. Reinstall the grille frame and the new grille (22, figure 1). Do not tighten hardware until after side panels are installed.
- 11. Install the clutch guard (3, figure 1) with two 5/16 x 3/4 capscrews, 5/16 plain washers, 5/16 lockwashers and 5/16 nuts. Install capscrews and plain washers from top.
- 12. Reconnect headlight wires and any other electrical connections.
- 13. Reinstall the side panels, hood, air cleaner and muffler strap. Tighten grille frame hardware.

NOTE

Both metric and standard hardware will be used during assembly. In the metric example M10-1.25 x 25, the "M10" signifies diameter size, the "1.25" is thread pitch, and the "25" is length in millimetres (25.4 mm = 1 inch). Where torques are necessary for metric hardware, they will be provided in foot-pounds.

2. Scrape all paint and debris from the lip of the crankshaft pulley, all the way around.
3. Install the crankshaft adapter (18, figure 1) to the flywheel with three M10 x 1-1/4 x 25 mm capscrews and lockwashers. Torque capscrews to 32 ft. lbs. (43.3 N.m). (On 4WD models, reach between engine and radiator to tighten bolts).
4. Start one of the chains (19, figure 1) onto the adapter (18). Turn the adapter (by turning fan), placing the chain on the adapter, until the chain is resting on top of the adapter.
5. Place the sprocket (21, figure 1) in the chain. Wrap the chain around both sprockets and connect at the bottom with the master link (figure 2). The open end of the connecting link should be opposite direction of engine pulley rotation.
6. Apply oil to the spline of the shaft sprocket (20, figure 1). Align the splines, and insert the shaft into sprocket (21).
7. Install the clutch assembly (figure 3) as follows. Be sure to install with side down as shown in figure 3.
 - a. Place the clutch in the frame, so that the sprocket on clutch is against the sprocket just installed.
 - b. Attach the clutch to the tractor frame with four 7/16-14 x 1 capscrews, 7/16 lockwashers and 7/16 nuts. Tighten finger tight at this time only.

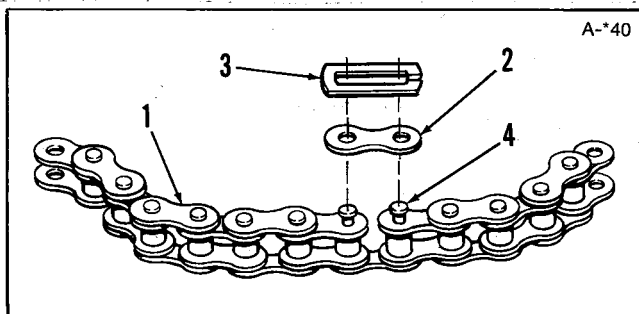

Figure 2. Chain Connecting Link

1. Chain
2. Connecting Link
3. Spring Clip
4. Master Link

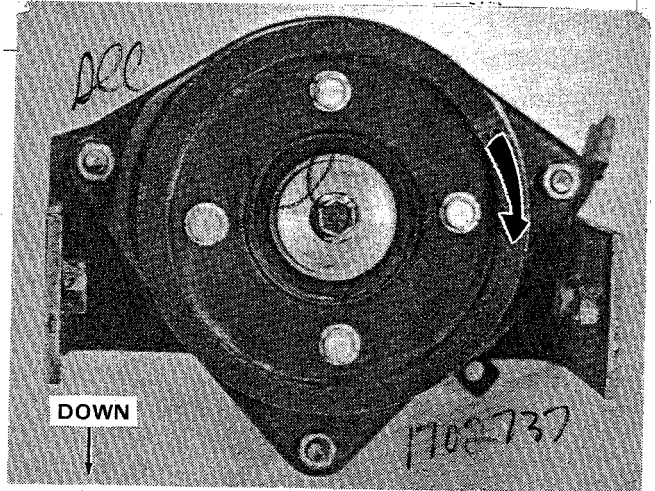

Figure 3.

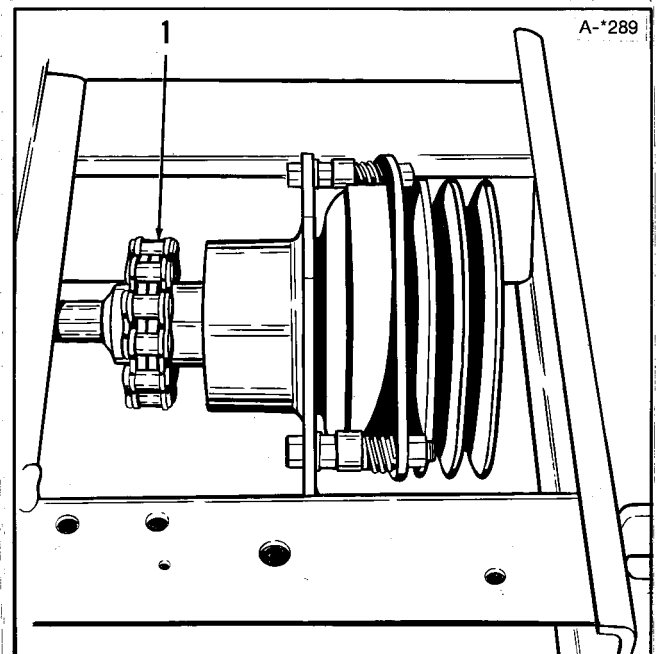

Figure 4.

1. Coupling Chain

- c. Place the remaining chain (1, figure 4) around both sprockets and secure with the master link. See figure 4.
 - d. Use a "square" as shown in figure 5 to align the clutch in the frame. Place the square against the clutch back plate and the top of the frame to insure that clutch is straight, then tighten the four bolts and nuts. (On some models, battery support will prevent square from being positioned as shown. Position square from bottom of frame).
8. Reinstall the battery box (if removed) and battery but do not connect the cables.

Free Manuals Download Website

<http://myh66.com>

<http://usermanuals.us>

<http://www.somanuals.com>

<http://www.4manuals.cc>

<http://www.manual-lib.com>

<http://www.404manual.com>

<http://www.luxmanual.com>

<http://aubethermostatmanual.com>

Golf course search by state

<http://golfingnear.com>

Email search by domain

<http://emailbydomain.com>

Auto manuals search

<http://auto.somanuals.com>

TV manuals search

<http://tv.somanuals.com>