

# INSTALLATION INSTRUCTIONS

HITCH AND LIFT ROD KIT  
MFG. NO. 1690809



## WARNING

Before installing the kit or making any adjustments, do the following; stop the engine, disengage the PTO, set the parking brake and shift into gear.

## IDENTIFICATION OF KIT PARTS

Not all of the parts will be needed. To install the kit on tractors that have a variable speed control lever, see figure 1. To install the kit on other tractors, see figure 2. The identification of the parts for both figures is below the figures. The quantity of each part for figure 1 is shown in the left column and for figure 2 in the right column.

## INSTALLATION ON TRACTORS WITH VARIABLE SPEED CONTROL LEVERS

1. Remove the two capscrews shown in figure 3. Store the front capscrew in case tractor is used without the hitch kit. The rear capscrew, lockwasher and nut will be reinstalled in a later step.
2. Install hitch assembly to the tractor as follows. Install hardware in steps "a", "b", "c", "d" and "e" loosely, until all hardware is installed, to avoid damage to threaded hole in transmission.
  - a. Attach the hitch (A, figure 1) to rear of tractor with three 3/8 x 1 capscrews (K), 3/8 plain washers (N), 3/8 lockwashers (L) and 3/8 nuts (M). Hitch is shown installed in figure 4.
  - b. Attach the left side of the hitch with the new flange screw (B, figure 1) and the capscrew, lockwasher and nut that were removed earlier. Use mounting holes shown in figure 3 (the flange screw is threaded into the transmission thru the front hole).
  - c. Attach the right side of hitch to tractor frame with the capscrew (C, figure 1), lockwasher (D) and nut (E).

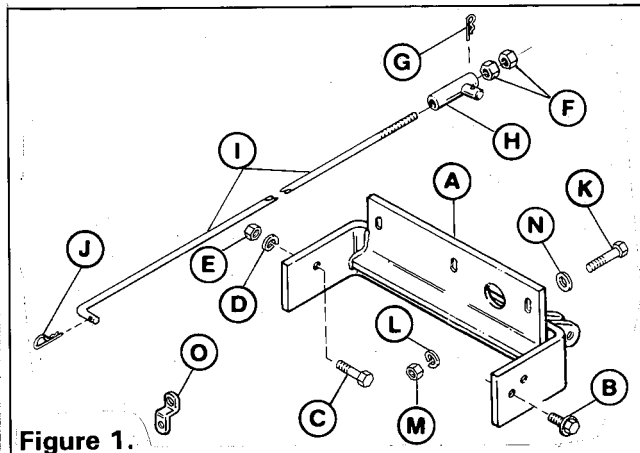


Figure 1.

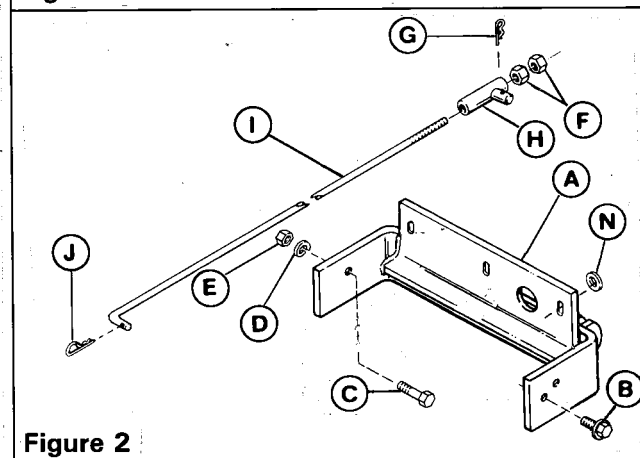


Figure 2.

| ITEM | NAME                         | Fig. 1<br>QTY. | Fig. 2<br>QTY. |
|------|------------------------------|----------------|----------------|
| A.   | Hitch                        | 1              | 1              |
| B.   | Flange Screw, 3/8-16 x 1-1/4 | 1              | 1              |
| C.   | Capscrew, 3/8-16 x 7/8       | 1              | 1              |
| D.   | Lockwasher, 3/8              | 1              | 1              |
| E.   | Nut, Hex, 3/8-16             | 1              | 1              |
| F.   | Nut, 1/2-20                  | 2              | 2              |
| G.   | Clip, Spring                 | 1              | 1              |
| H.   | Guide Tube                   | 1              | 1              |
| I.   | Lift Rod                     | 1              | 1              |
| J.   | Clip                         | 1              | 1              |
| K.   | Capscrew, 3/8 x 1            | 3              | 0              |
| L.   | Lockwasher, 3/8              | 3              | 0              |
| M.   | Nut, 3/8                     | 3              | 0              |
| N.   | Washer, 3/8                  | 3              | 3              |
| O.   | Bracket                      | 1              | 0              |

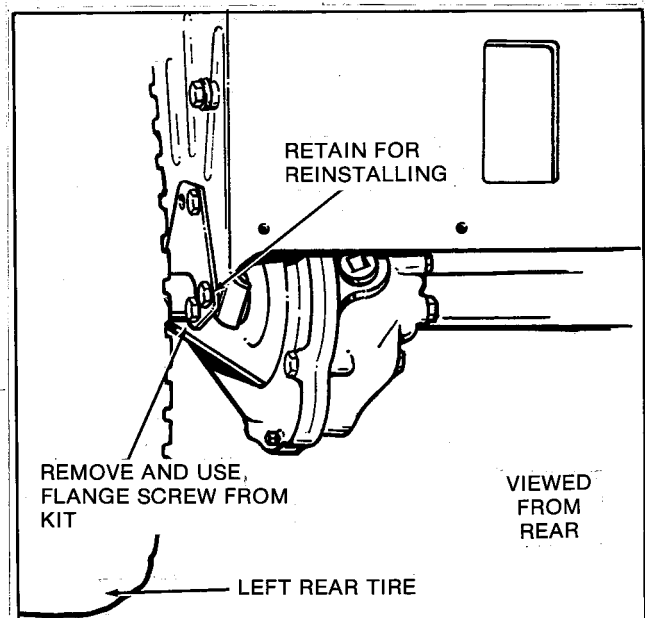
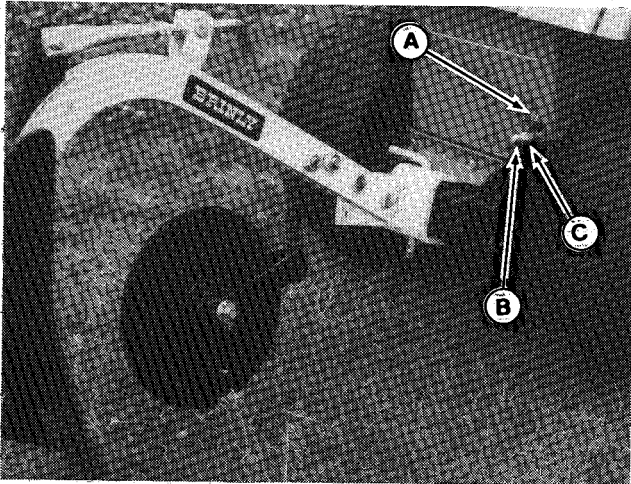


Figure 3.

FORM - 1672092  
PRINTED IN U.S.A.  
829

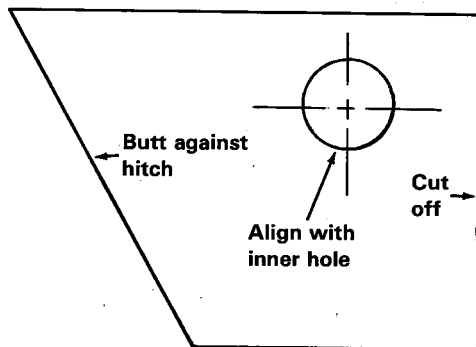
## LIFT ROD INSTALLATION - ALL MODELS

1. Insert the front end of the lift rod thru the hole in the tractor lift lever (underneath tractor). Install the clip (J, figure 1 or 2) thru the end of the lift rod.
2. Install the attachment according to the attachment Operator's Manual.
3. Install the guide tube (H) and nuts (F) onto the end of the lift rod. (Be sure tube is installed as shown in figure 1 or 2 with short side toward rear). Insert the prong of the guide tube thru hole in attachment lift arm and install the clip (G) thru the prong. Figure 8 shows a typical installation.
4. Operate the tractor lift lever to be sure the attachment can be raised for transportation and lowered for operation. Move the nuts (C, figure 8) toward the guide tube to increase ground clearance when attachment is in raised position. Move the nuts away from guide for more depth. Tighten nuts together.

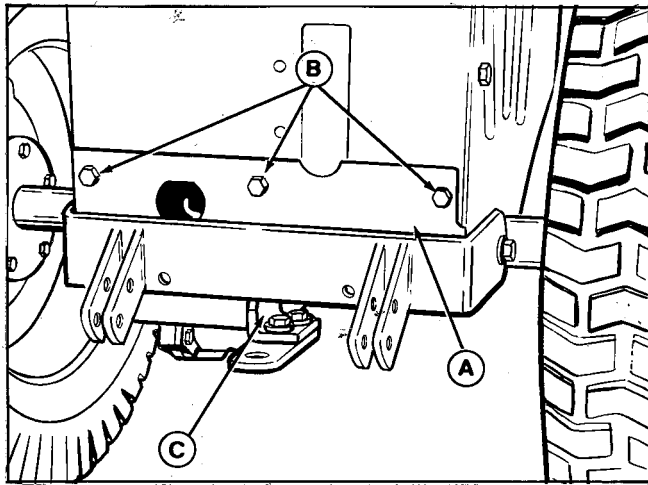


**Figure 8. Typical Installation**

- A. Spring Clip
- B. Lift Rod
- C. Nuts



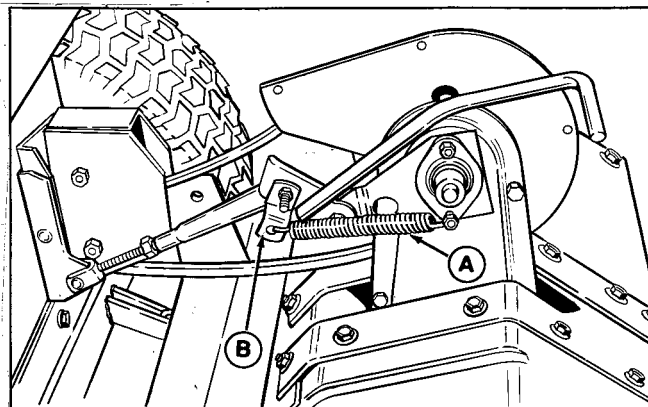
**Figure 9. Template**



**Figure 4.**

- A. Hitch**
- B. Capscrews**
- C. Drawbar**

3. Make sure all fasteners are aligned then tighten securely.
4. The bracket (O, figure 1) is used on the tiller. Unhook the spring (A, figure 5) from the screw and remove both nuts. Place the bracket (B) on the screw and install outer nut. Hook the spring (A) into the hole in bracket.



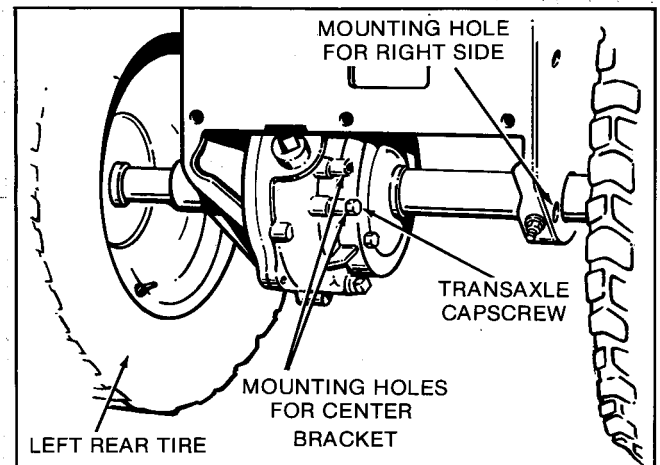
**Figure 5.**

- A. Spring**
- B. Bracket**

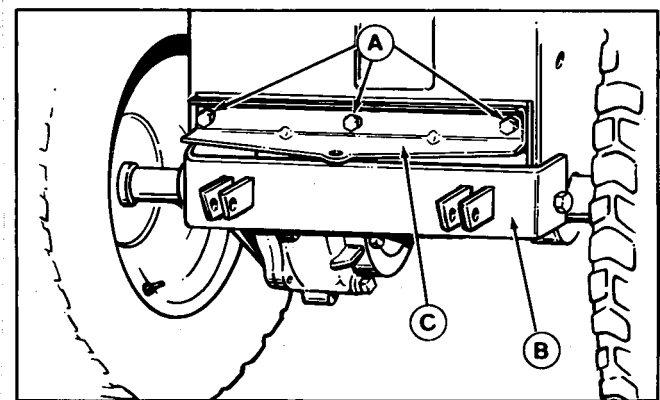
### HITCH INSTALLATION ON OTHER TRACTORS (With Three Forward Speeds)

1. The hitch arms must be shortened so that inner holes can be used. Cut out the template (figure 9). Align the template hole with the inner hole in hitch and edges of template with edges of hitch. Scribe a line along outer edge of template. Remove the template and saw off the hitch arm along line. Repeat for each hitch arm.
2. Remove the tractor drawbar by removing three capscrews, lockwashers, and nuts. Retain this hardware for reinstallation.

3. Remove the two capscrews from left side shown in figure 3. Store the front capscrew for future use in case the hitch is removed from tractor. The rear capscrew will be reinstalled in a later step.
4. Attach the hitch and drawbar to the tractor with the drawbar hardware which was removed in step 1 and three 3/8 washers (N, figure 1) from kit. See figure 7.
5. Install the hardware in steps "a" & "b" loosely, until all hardware is installed, to avoid damage to threaded hole in transmission housing.
  - a. Secure the right side of the hitch with capscrew (C, figure 2), lockwasher (D) and nut (E) in mounting hole shown in figure 6.
  - b. Secure the left side of the hitch with one flange screw (B, figure 2) from kit and one existing capscrew, lockwasher and nut. See figure 3.
6. Make sure all hardware is aligned then tighten securely.



**Figure 6.**

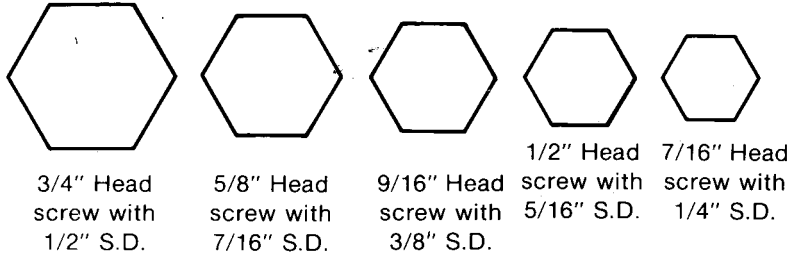


**Figure 7.**

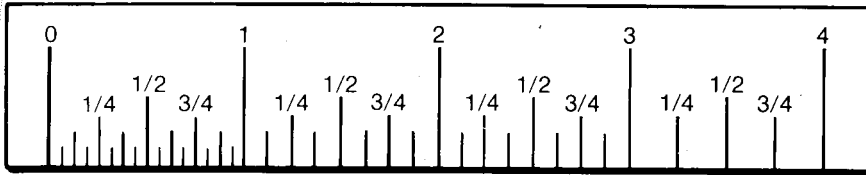
- A. Capscrews**
- B. Hitch**
- C. Drawbar**

## HEX CAPSCREW IDENTIFICATION

Shown below are actual size hex heads for standard screw sizes. Example: a 1/4" screw has a 7/16 head and thus requires a 7/16 wrench. To measure length, use the scale below.



**S.D. = Shaft Diameter**



## WASHER AND NUT IDENTIFICATION

Place the washer or nut on the above scale to determine the inside diameter. The actual inside diameter can vary 1/16 inch. Use the scale for comparison.

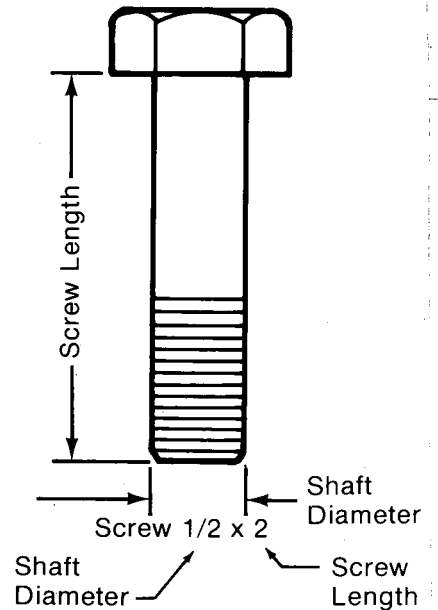
# STANDARD FASTENER IDENTIFICATION CHART

Hardware sizes are given in the illustrations throughout this manual.

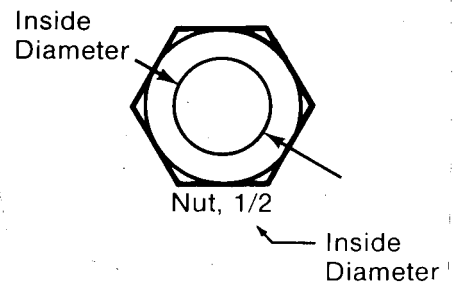
If a washer or nut is identified as "washer, 1/2" or "nut, 1/2", this means the inside diameter is 1/2 inch.

If a screw is identified as "screw, 1/2 x 2", this means the shaft diameter is 1/2 inch and the shaft of the screw is 2 inches long. If a screw is identified as "screw, 1/2-16 x 2", the number "16" means that the screw has 16 threads per inch.

## SAMPLE: SCREW IDENTIFICATION



## SAMPLE: NUT IDENTIFICATION



## Free Manuals Download Website

<http://myh66.com>

<http://usermanuals.us>

<http://www.somanuals.com>

<http://www.4manuals.cc>

<http://www.manual-lib.com>

<http://www.404manual.com>

<http://www.luxmanual.com>

<http://aubethermostatmanual.com>

Golf course search by state

<http://golfingnear.com>

Email search by domain

<http://emailbydomain.com>

Auto manuals search

<http://auto.somanuals.com>

TV manuals search

<http://tv.somanuals.com>