

Parts Manual for

SNAPPER®

CLEAN SWEEP TWIN CATCHER

MODEL
1694498

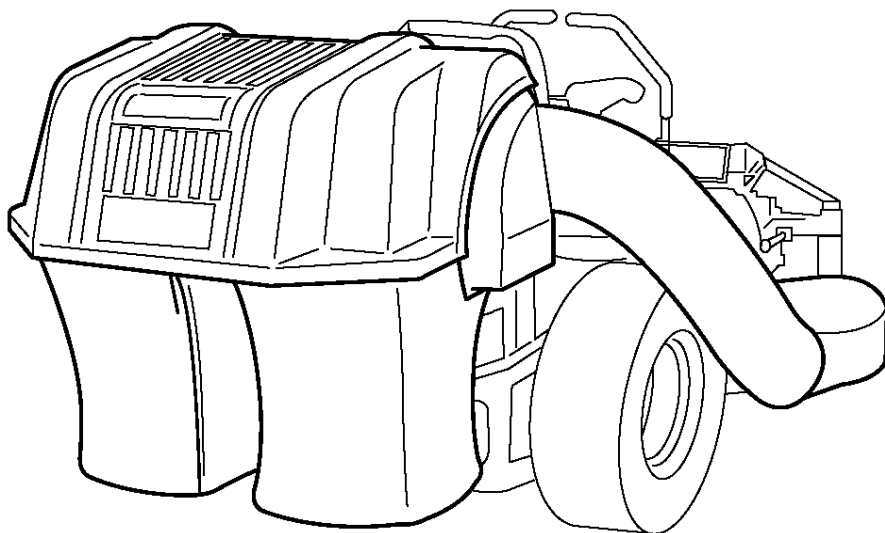

SNAPPER® McDonough, GA, 30253 U.S.A.

COPYRIGHT © 2005
SNAPPER PRODUCTS, INC.
ALL RIGHTS RESERVED.

Revision IR, 7/15/2005

Manual No. 1694498
TP 400-5075-IR-AT-N

PAGE	GROUP
4	Cover & Bag Group - Twin
8	Front Weight Carrier Group
10	Mount Group
14	Tubes & Support Group - Twin

Cover & Bag Group - Twin

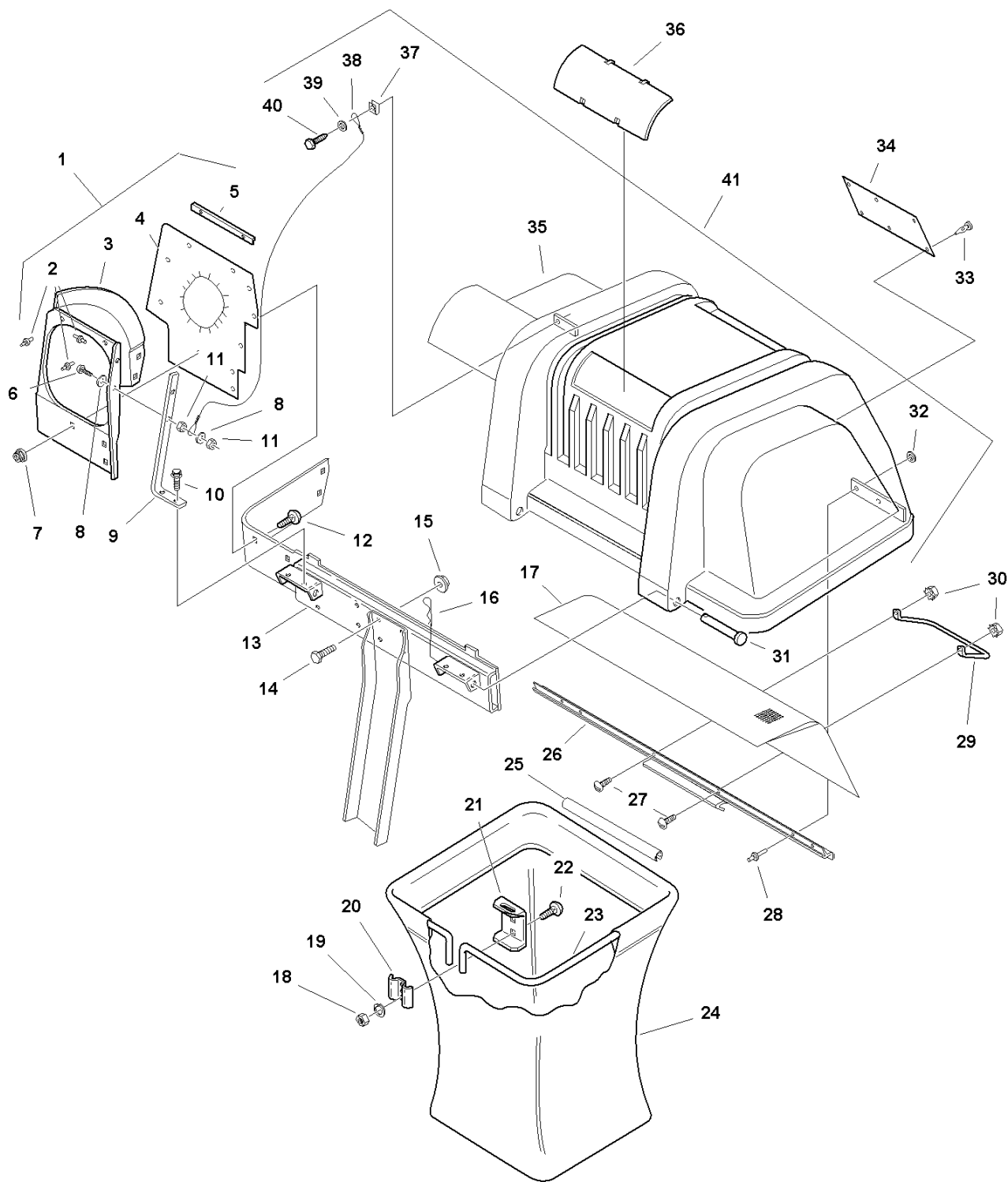

Cover & Bag Group - Twin

Item	Part No	Qty	Description	Note
1	1704615	1	TUBE ASSEMBLY Support (Incl. Ref. Nos. 2, 3, 4, 5, 6, 8, 9 &11)	
2	1960381	7	RIVET, Pop	
3	1704075	1	SUPPORT, Tube	
4	1704135	1	SEAL, Cover	
5	1704508	3	BRACKET, Seal	
6	1960399	1	SCREW, Round Head, #8-32 x 7/8	
7	1930642	5	LOCKNUT, Flange, 1/4-20	
8	1960096	2	WASHER	
9	1704507	1	STRAP, Tube Support	
10	1927428	2	SCREW, Taptite, 1/4-20 x 3/8	
11	1960077	2	NUT, Hex, Lock, #8-32	
12	1960252	5	CARRIAGE BOLT, 1/4-20 x 5/8	
13	1703822	1	CROSS ASSEMBLY	
14	1921966	4	CAPSCREW, Hex Head, 3/8-16 x 7/8	
15	1928352	4	NUT, Hex, Whizlock, 3/8-16	
16	1960221	2	CLIP, Hairpin	
17	1703700	1	SCREEN	
18	1917372	4	NUT, Hex, 5/16-18	
19	1917356	4	LOCKWASHER, 5/16	
20	1672023	2	CLAMP	
21	1703807	2	HANGER	
22	1931333	4	CARRIAGE BOLT, 5/16-18 x 3/4	
23	1703855	2	HOOP, Bag	
24	1703764	2	BAG, Grass	
25	1675707	2	TUBE CLIP, Grass Bag	
26	1704057	1	SEAL, Clip	
27	1930531	2	SCREW, Truss Head, #10-32 x 1/2	
28	1675043	4	RIVET, Pop	
29	1703853	1	HANDLE, Latch	
30	1928919	2	NUT, Hex, #10-32	
31	2860367	2	PIN, Round Head	
32	1910531	4	WASHER	
33	1667248	6	CLIP, Canoe	
34	1704405	1	DECAL, Safety	
35	1704033	1	COVER	
36	1704180	2	WINDOW	
37	1933886	1	NUT, Speed	

Footnotes

Cover & Bag Group - Twin

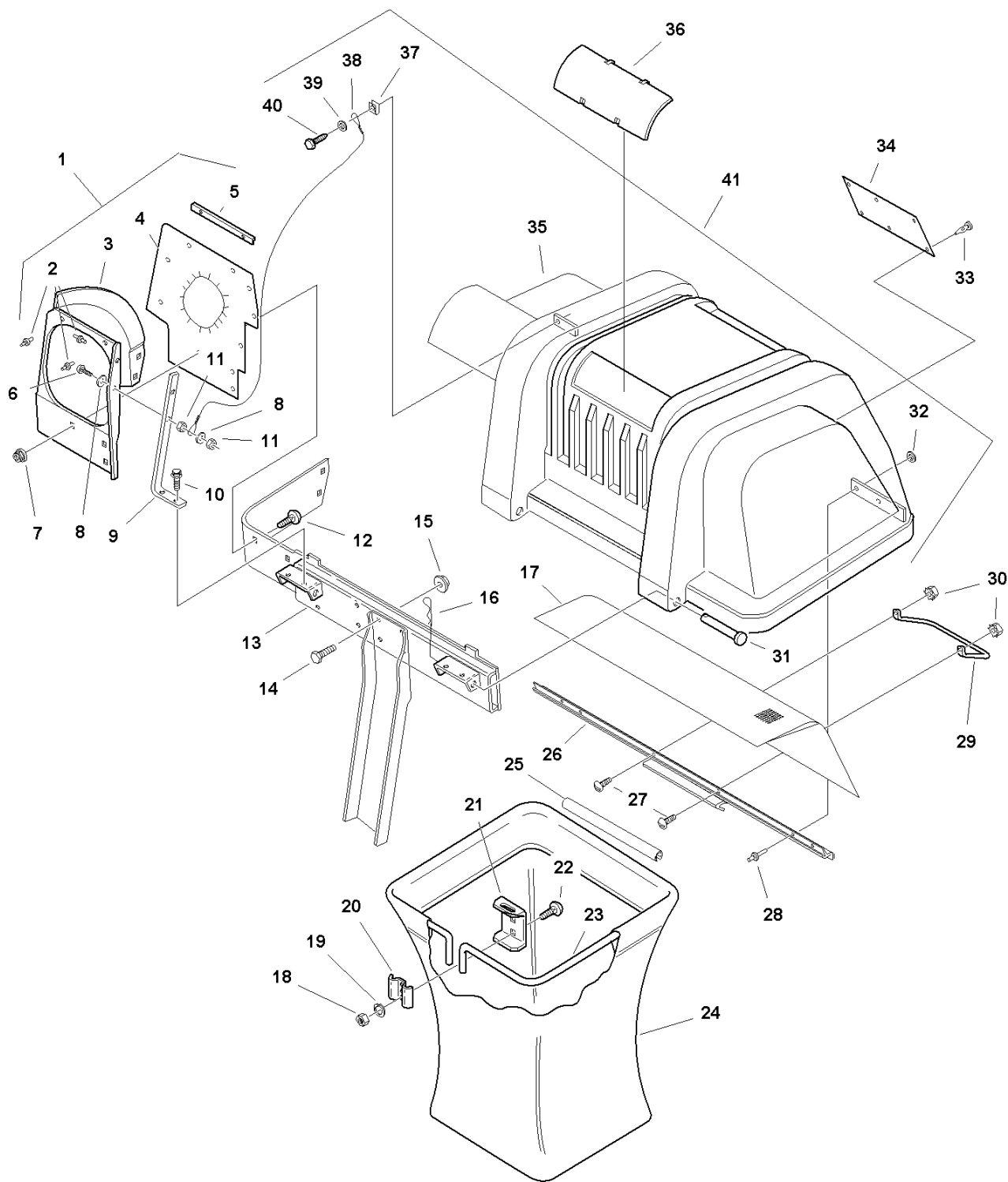

Cover & Bag Group - Twin

Item	Part No	Qty	Description	Note
38	1705876	1	CABLE, Double Loop	
39	1921319	1	WASHER, 1/4	
40	1960400	1	SCREW, Self-tapping, #10-12 x 5/8	
41	1704056	1	COVER ASSEMBLY (Incl. Ref. Nos. 17, 26, 28, 32, 37, 38, 39 & 40)	

Footnotes

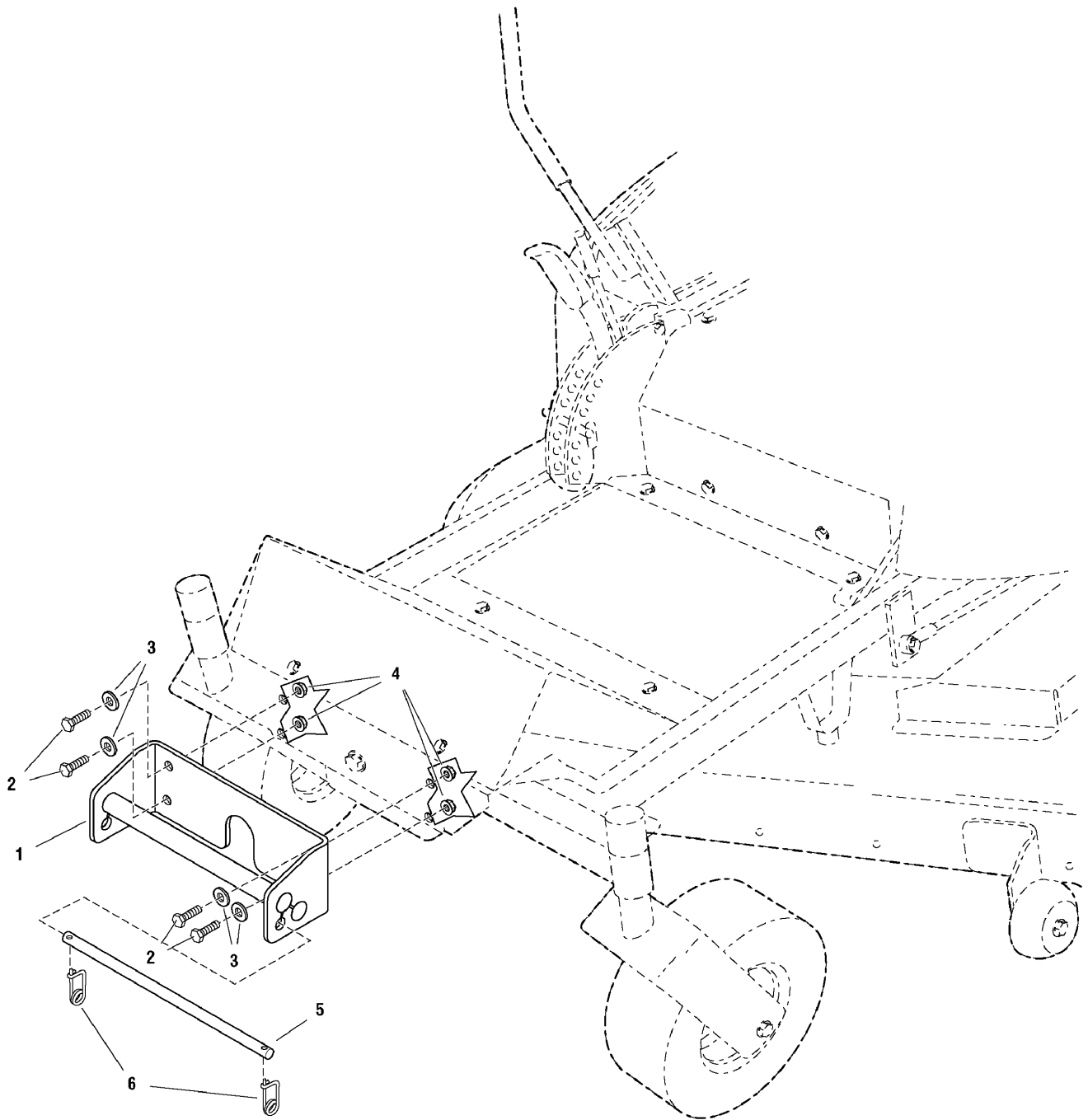

Front Weight Carrier Group

Item	Part No	Qty	Description	Note
1	5049082	1	HOLDER ASSEMBL, Weight	
2	1921333	4	CAPSCREW, Hex Head, 5/16-18 x 1 G5 Black	
3	1919326	4	WASHER, 5/16 (0.34ID x 0.75OD x .06THK) Black	
4	1927557	4	NUT, Hex Flange Whiz Lock, 5/16-18 Large Black	
5	5049143	1	ROD, Retaining, 1/2 x 13-3/4LG	
6	2176012	2	RETAINER, Pin, Spring	

Footnotes

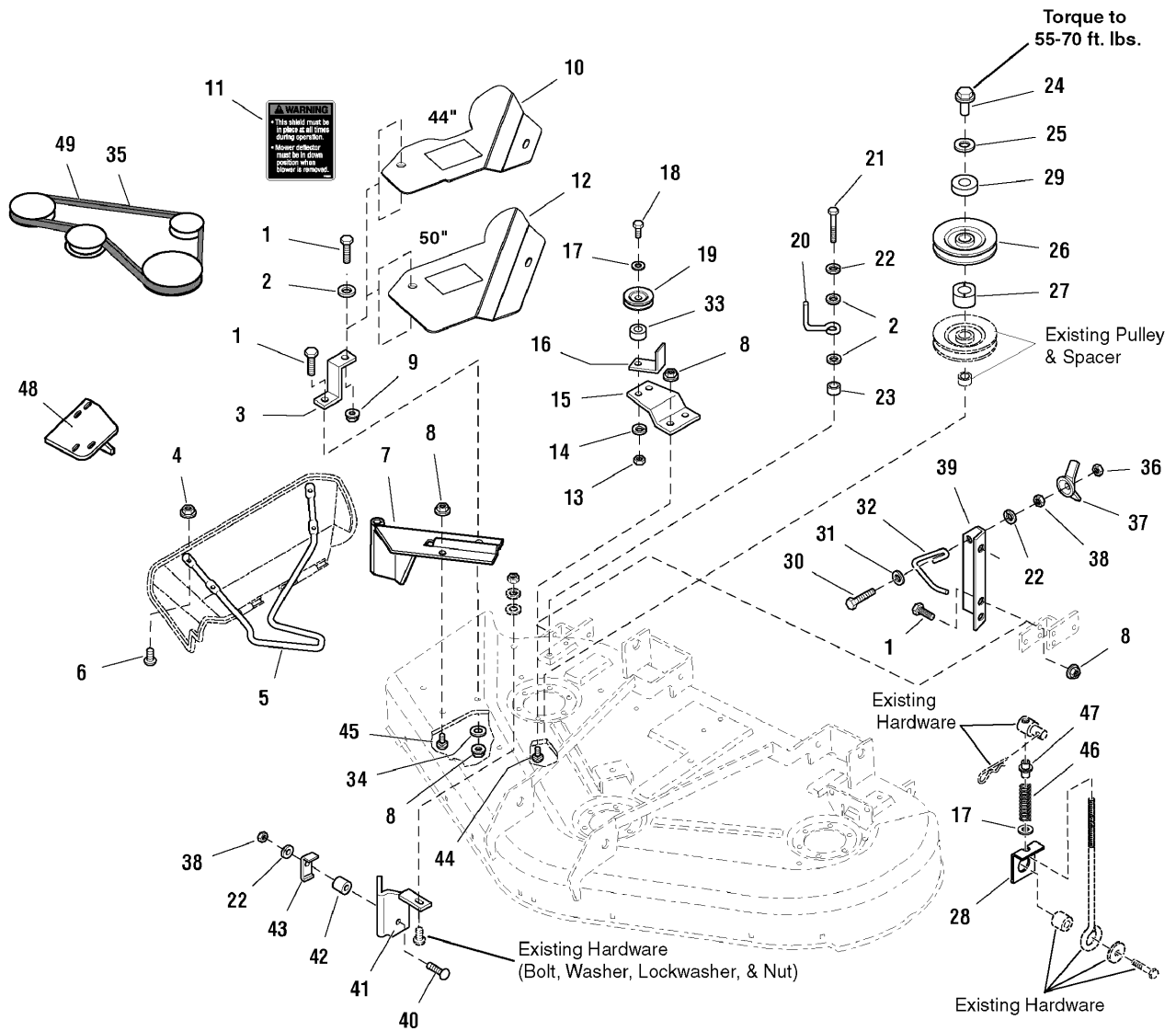

Mount Group

Item	Part No	Qty	Description	Note
1	1921333	4	CAPSCREW, Hex Head, 5/16-18 x 1 G5 Black	
2	1919326	3	WASHER, 5/16 (0.34ID x 0.75OD x .06THK) Black	
3	1718304	1	SUPPORT, Belt Cover 10GA 1.0WD 3.0LG	
4	1933896	4	NUT, Hex Lock, 10-24 with Nylon Insert NC3B Black	
5	1718295	1	ROD, .375DIA 22.0LG	
6	1960404	4	SCREW, Truss Head Phillips, #10-24 x 3/4 Black	
7	1722546	1	PIVOT & BRACKETS ASSEMBLY, 38, 44 & 50"	
8	1931277	6	NUT, Hex Flange Whiz Lock, 5/16-18 Small Black	
9	1919438	1	NUT, Hex Lock ESNA Light, 5/16-18NC-3B Black	
10	5049171	1	COVER, Belt 44" 12GA	
11	1717291	2	DECAL, WARNING Sheild & Mower Deflector	
12	5049170	1	COVER, Belt 50" 12GA	
13	1916950	1	NUT, Hex 3/8-16 NC-2B Black	
14	1916965	1	LOCKWASHER, Spring 3/8	
15	1704768	1	BRACKET, Z .164TH 5.88WD 3.21LG	
16	1724373	1	BRACKET, L 12GA 1.24WD 2.24LG 2.28LG	
17	1924940	1	WASHER, 3/8 (0.41ID x 0.87OD x .08THK) Black	
18	1923701	1	CAPSCREW, Hex Head, 3/8-16 x 2 G5 Black	
19	1714817	1	PULLEY, Idler, 2.75OD 0.380ID 0.50W	
20	2172845	1	STOP, Belt, .188WIRE 1.750,2.250 Black	
21	1921221	1	CAPSCREW, Hex Head, 5/16-18 x 1-1/2 G5 Black	
22	1917356	1	LOCKWASHER, Spring 5/16 Black	
23	1710703	1	SPACER, 0.328ID x 0.499OD x 0.625LG Powdered Metal	
24	1713523	1	NUT, Sleeve, 9/16-18 x 3/4INT x 1.34LG Black	
25	1603592	1	WASHER, Bellville, 0.88ID x 1.75OD x .08TH Black	
26	1709941	1	PULLEY, 04.30OD 1.000ID 0.579 Groove 9GA	
27	1713623	1	HUB, .79ID x 1.5OD x .73LG Metafusion	
28	5049145	1	PLATE, Spring Support 10GA	
29	5049088	1	SPACER, 0.812ID x 1.75OD x 0.50LG	
30	1960318	1	CAPSCREW, Hex Head, 5/16-18 x 2-1/2 G5 Flat Black	
31	1919381	1	WASHER, 5/16 (0.34ID x 1.00OD x .13THK) Black	
32	1705064	1	SPRING, Latch, .125WIRE 4.3LG Black	
33	2108717	1	SPACER, 0.390ID x 0.625OD x .265LG	
34	1922755	1	WASHER, 3/8 (0.41ID x 1.00OD x .13THK) Black	
35	1705142	1	V-BELT, 3L, 44" Mower Deck	
36	1923362	1	NUTHex Centerlock, 5/16-18 Black	
37	1679163	1	NUT & CUP ASSEMBLY, Wing, 5/16-18 E-Coat	

Footnotes

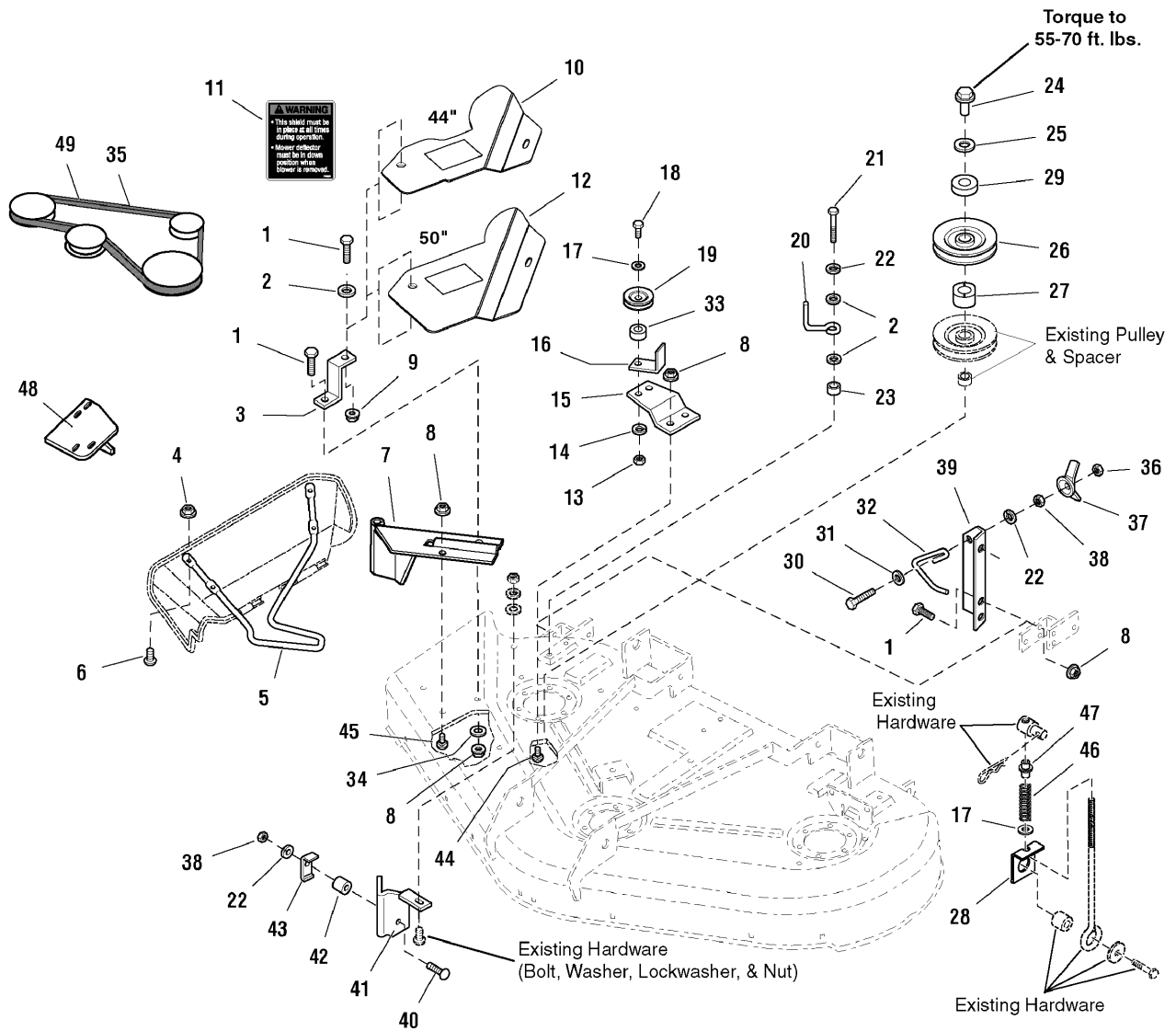

Mount Group

Item	Part No	Qty	Description	Note
38	1917372	2	NUT,Hex, 5/16-18 NC-2B Black	
39	1704982	1	PLATE, Anchor	
40	1960223	1	CARRIAGE BOLT, 5/16-18 x 1-1/4 G5 Black	
41	1659867	1	BRACKET ASSEMBLY, Cutoff, 44"	
42	1666294	1	SPACER, 0.385ID x 0.668OD x 0.455LG Powdered Metal Black	
43	1705308	1	BRACKET, L 12GA 1.00WD 1.98LG 0.62LG	
44	1923325	2	CAPSCREW, Hex Head, 5/16-18 x 7/8 G5 Black	
45	1931333	1	CARRIAGE BOLT, 5/16-18 x 3/4 G5 Black	
46	5049159	1	SPRING, Compression, 0.720OD x 2.25 LG .085 Wire	
47	5049144	1	SPACER, 0.390ID x 0.75OD x 1.13 LG YELLOW	
48	1704983	1	BRACKET & PLATE ASSEMBLY, Clamp	
49	1707956	1	V-BELT, 3L, 50" Mower Deck	

Footnotes

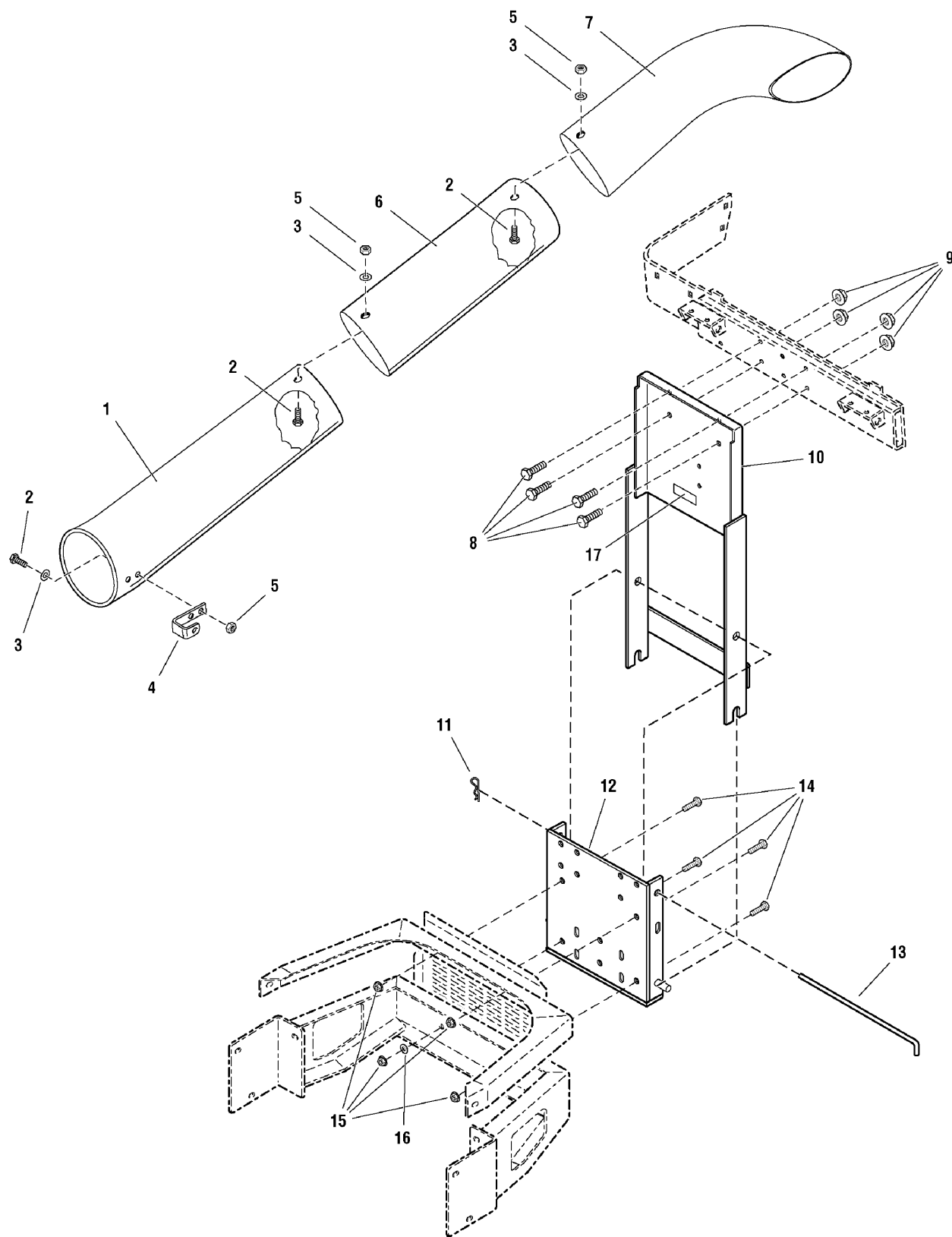

Tubes & Support Group - Twin

Item	Part No	Qty	Description	Note
1	5049152	1	CHUTE, Grass Catcher Lower, Black	
2	1960404	7	SCREW, Truss Head Phillips, #10-24 x 3/4 Black	
3	1960096	7	WASHER, 3/16 (0.187ID x 0.75OD x .06THK) Black	
4	1705063	1	CLIP, Spring, 1.40 x 1.48OP x 3.50LG 0.88WD	
5	1933896	7	NUT, Hex Lock, 10-24 with Nylon Insert, NC3B Black	
6	5049151	1	CHUTE, Grass Catcher Middle, Black	
7	1704283	1	ELBOW, Vacuum Collector, 5.57ID 30.29LG .090	
8	1921965	4	CAPSCREW, Hex Head, 3/8-16 x 3/4 G5 Black	
9	1928352	4	NUT, Hex Flange Whiz Lock, 3/8-16 Large Black	
10	5046687	1	FRAME ASSEMBLY, Bagger	
11	1960033	1	CLIP, Hair Pin, .125DIA Spring Wire, 2.562LG Black	
12	5046995	1	FRAME ASSEMBLY, Bumper Mounting	
13	5046693	1	ROD, Support, .625DIA 13.0LG	
14	1921176	4	CAPSCREW, Hex Head, 1/2-13 x 1-1/4 G5 Black	
15	1960668	4	NUT, Hex Flange Whiz Lock, 1/2-13 Black	
16	1924361	1	WASHER, 1/2 (0.53ID x 1.25OD x .08THK) Black	
17	*	1	DECAL, ID Plate	<i>* Not a serviceable part.</i>

Footnotes

Parts Manual for

SNAPPER[®]

CLEAN SWEEP TWIN CATCHER

IT IS THE POLICY OF SNAPPER TO IMPROVE ITS PRODUCTS
WHENEVER IT IS POSSIBLE AND PRACTICAL TO DO SO. WE
RESERVE THE RIGHT TO MAKE CHANGES OR ADD
IMPROVEMENTS AT ANY TIME WITHOUT INCURRING ANY
OBLIGATION TO MAKE SUCH CHANGES ON PRODUCTS

SNAPPER McDonough, GA, 30253 U.S.A.

Free Manuals Download Website

<http://myh66.com>

<http://usermanuals.us>

<http://www.somanuals.com>

<http://www.4manuals.cc>

<http://www.manual-lib.com>

<http://www.404manual.com>

<http://www.luxmanual.com>

<http://aubethermostatmanual.com>

Golf course search by state

<http://golfingnear.com>

Email search by domain

<http://emailbydomain.com>

Auto manuals search

<http://auto.somanuals.com>

TV manuals search

<http://tv.somanuals.com>