

OPERATOR'S MANUAL

30'' OFFSET ROTARY TILLER

FILE COPY

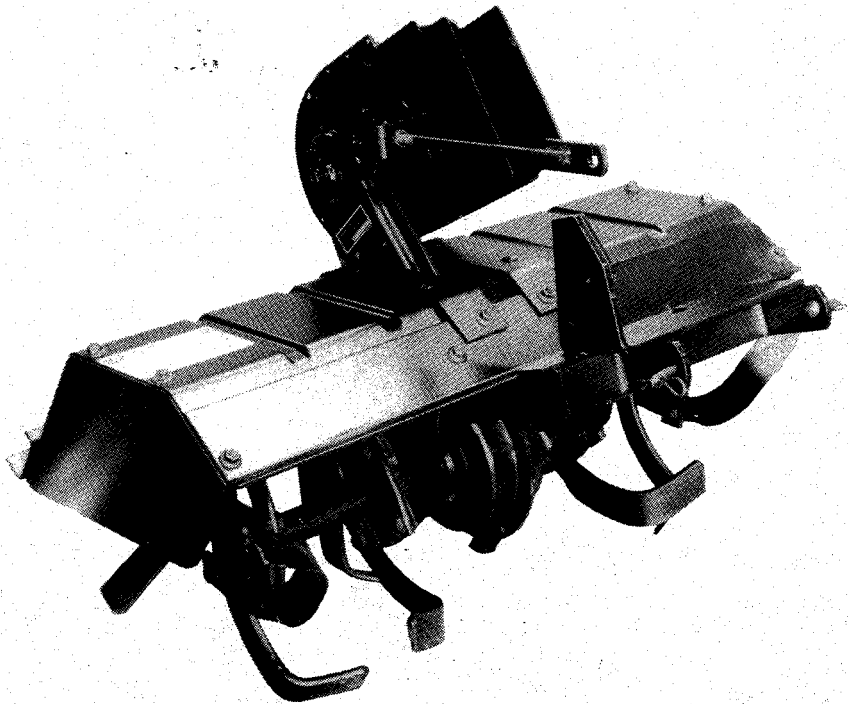

FORM - 1701240
PRINTED IN U.S.A.
876

30'' OFFSET ROTARY TILLER
MFG. NO. 1691277

Table of Contents

Accessories	Inside Front Cover
Safety Rules	1
Decals	2
Parts Identification	2
Layout of Assembly Parts	3
Installation and Removal	4
Installation	4
Removal	7
Adjustments	8
Belt Tension	8
Lift Rod	8
Operation	9
Controls	9
Checks Before Starting	9
Transporting	9
Turning or Backing When Tilling	9
Engine Speed & Ground Speed	9
Starting & Stopping	9
Tilling Suggestions	9
Normal Care	10
Lubrication	10
Normal Storage	10
Off-Season Storage	10
Troubleshooting & Service	11
Troubleshooting Procedures	11
Tine Replacement	12
Tiller Drive Belt Replacement	12
PTO Belt Replacement	13
Tractor Setup	14
Specifications	Inside Back Cover

Accessories

Rear wheel weights and front counterweights are recommended. For operation on slopes greater than 15% (8.5°), front counterweights are required.

An electric lift switch is available as an option.

Safety Rules



Read these safety rules and follow them closely. Failure to obey these rules could result in loss of control of vehicle, severe personal injury to yourself or bystanders, or damage to property or equipment.

The triangle  in the text signifies important cautions or warnings which must be followed.

GENERAL

- Read the operator's manual carefully. Be thoroughly familiar with the controls and proper use of the equipment. Know how to stop the unit and disengage the controls quickly.
- Never allow children to operate equipment. Never allow adults to operate equipment without proper instructions.
- Keep the area of operation clear of all persons, especially small children and pets.
- Use only attachments or accessories designed for your machine. See your dealer for a complete list of recommended attachments or accessories.

PREPARATION

- **Make sure:**
 - a. Tractor and attachments are in good operating condition.
 - b. All safety devices and shields are in place and in good working condition, and
 - c. All adjustments have been made.
- Handle gasoline with care – it is highly flammable.
 - a. Use approved gasoline container.
 - b. Never remove the cap of the fuel tank or add gasoline to a running or hot engine, or fill the fuel tank indoors. Wipe up spilled gasoline.
- Wear heavy footwear. Do not operate tractor when barefoot or when wearing open sandals or canvas shoes.
- Disengage all attachments and clutches and shift into neutral before attempting to start engine.
- Do not run the engine indoors. Exhaust fumes are deadly.
- Thoroughly inspect the area where the rotary tiller is to be used and remove wires and other foreign objects which might get caught on tines.

OPERATION

- Disengage all clutches and shift into neutral before starting engine.

- Disengage power to rotary tiller when transporting or not in use.
- Stay alert for hidden hazards or traffic when crossing roadways. Do not carry passengers.
- Never operate rotary tiller without guards, plates, or other safety protective devices in place.
- Never allow anyone in back of unit.
- Do not stop or start suddenly on slopes. Till up the face of the slopes; never across the face.
- After striking a foreign object, stop the engine, disengage power take-off, and remove ignition key. Thoroughly inspect the rotary tiller for any damage before restarting and operating the rotary tiller.
- When cleaning, repairing, or inspecting, make certain rotary tiller and all moving parts have stopped. Remove ignition key to prevent accidental starting.
- Never attempt to make any adjustments while engine is running.
- Be especially careful not to touch tractor or attachment parts which might be hot from operation. Allow such parts to cool before attempting to maintain, adjust, or service.
- Never operate the rotary tiller without good visibility or light. Always be sure your feet are properly located on the footrests and keep a firm hold on the steering wheel.
- Stop engine, disengage power take-off and remove ignition key whenever you leave the operating position and before making repairs, adjustments, or inspections.
- Take all possible precautions when leaving the vehicle unattended. Disengage power take-off, lower the attachment, shift into neutral, set the parking brake, stop the engine, and remove the key.

MAINTENANCE AND STORAGE

- Check belts, nuts, spring clips, etc. at frequent intervals for proper tightness to be sure equipment is in safe working condition.

Decals

Do not remove or paint over the decal placed on the top and rear faces of the tiller. This decal provides important safety rules for operation of the tiller.



Figure 1. Safety Decal

Parts Identification

When ordering replacement parts for your rotary tiller, be prepared to give your dealer the identification number found on the identification plate shown in Figure 2. We suggest that you locate the number and record it below for easy reference.

Refer to ID no. when writing or ordering parts.
ID NO.

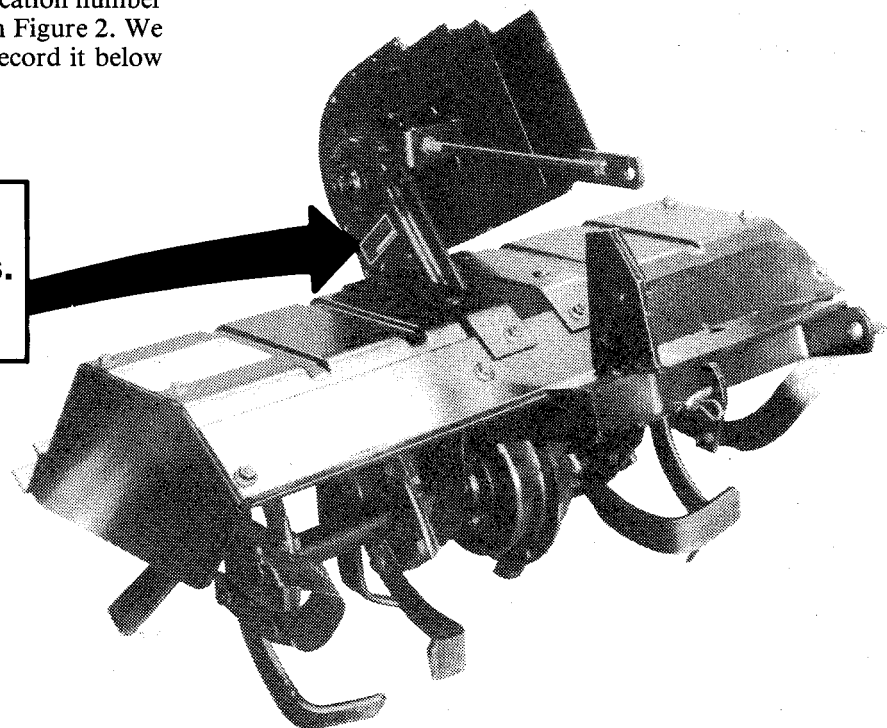

Figure 2. ID Number

Layout of Assembly Parts

The following chart should assist you in laying out the major assembly parts contained in the tiller kit. These parts are presented in order of assembly according to instruction steps in "Tractor Setup" and "Installation"

TRACTOR SETUP		
<p>Step 4</p>  <p>Idler Box Bracket</p>	<p>Step 5</p>  <p>Jackshaft Bracket</p>	<p>Step 6</p>  <p>Idler Pulley Bracket</p>
<p>Step 7</p>  <p>Bushing Assembly</p>	<p>Step 8</p>  <p>Pin</p>	<p>Step 9</p>  <p>Pin</p>
INSTALLATION		
<p>Step 2</p>  <p>Jackshaft Assembly</p>	<p>Step 5</p>  <p>Clutching Rear Idler Pulley</p>	<p>Step 6</p>  <p>Idler Box Assembly</p>

Figure 3. Tiller Kit Assemblies

Installation and Removal

INSTALLATION

1. Prior to tiller installation, tractor must be equipped with Hitch and Lift Kit and several Tiller Kit components. If your tractor has not been prepped by your dealer, begin with "Tractor Setup" instructions on page 14.
2. Install jackshaft assembly as follows:
 - a. Remove neutral return rod (A, Figure 4) from pin and insert through jackshaft assembly (B) between pulley and crossshaft.
 - b. Slide assembly (B) onto jackshaft bracket front bolts and nuts (C) already installed on bracket.
 - c. Secure assembly with clevis pins (D) in rear. Pins must face the inside of the bracket. Insert spring clips to secure clevis pins.

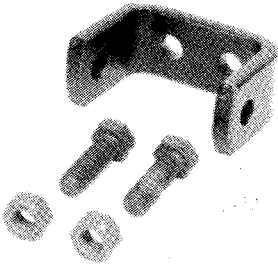
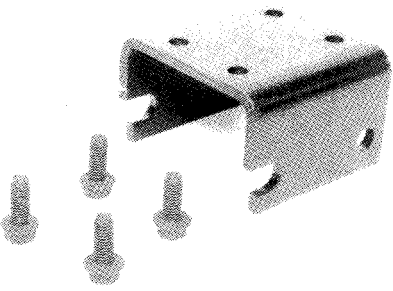
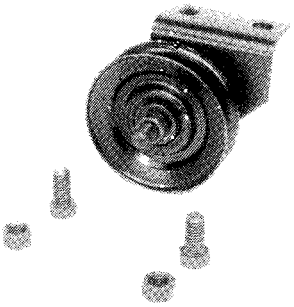
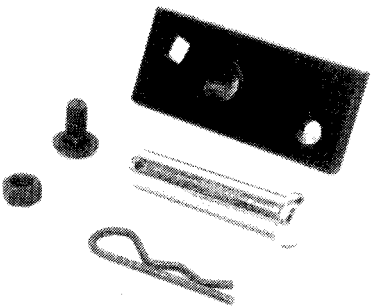
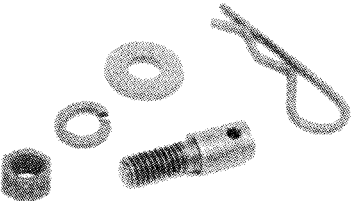
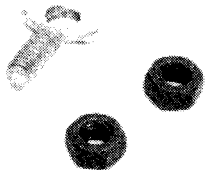
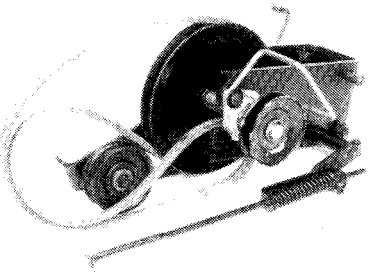
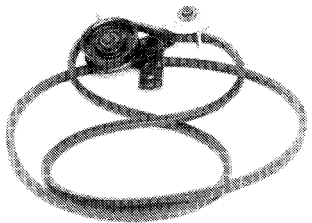
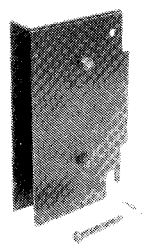
NOTE

Smaller clevis pins with flat heads must be used. Larger pins with round heads must be used to secure tiller to hitch.

- d. Reinstall neutral return rod (A) to pin and secure with spring clip.
- e. Install spring (E) in hole through frame opening.
- f. Install PTO rod (F) into hole marked "MOW" on PTO arm (G).

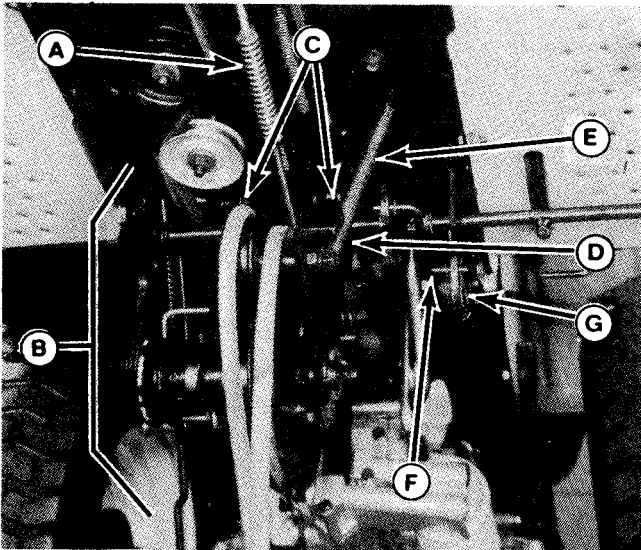

Figure 4.

- A. Neutral Return Rod
- B. Jackshaft Assembly
- C. Bolts and Nuts
- D. Clevis Pin
- E. Spring
- F. PTO Rod
- G. PTO Arm

3. Remove belt (A, Figure 5) from jackshaft idler pulley (B). Turn belt by hand so that higher portion of belt is on left side of tractor. Position belt around drive pulley (C) and replace belt around idler pulley (B). Make sure that belt is positioned as shown in Figure 4.

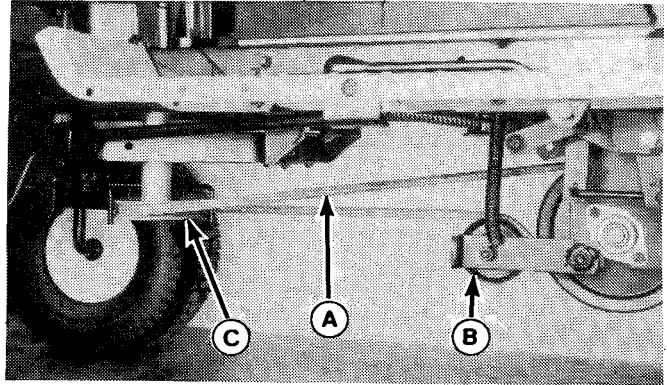

Figure 5.

- A. Belt
- B. Idler Pulley
- C. Drive Pulley

4. Position drive pulley belt guides (A, Figure 6) so that there is a 1/16" space between belt and guide. Tighten guides.

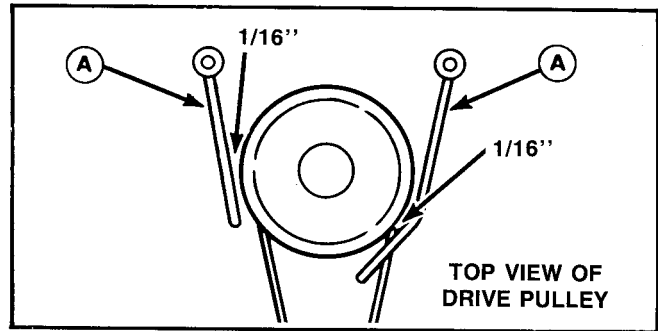

Figure 6.

- A. Belt Guide

5. Install clutching idler pulley assembly as follows:
 - a. Insert clutch rod (A, Figure 7) into top hole (closest to pulleys) of pulley assembly (B). Secure with spring clip.
 - b. With pulleys facing the underside of tractor, raise assembly to bushing assembly (C).
 - c. Push pin (D) through assemblies (B & C) and secure with spring clip.
 - d. Install belt (E) on jackshaft pulley (F).
 - e. Loosen nut (A, Figure 22) on rear idler pulley (B). Install belt around top side of pulley and tighten pulley nut.
 - f. Feed belt through knockout panel hole at rear of tractor.

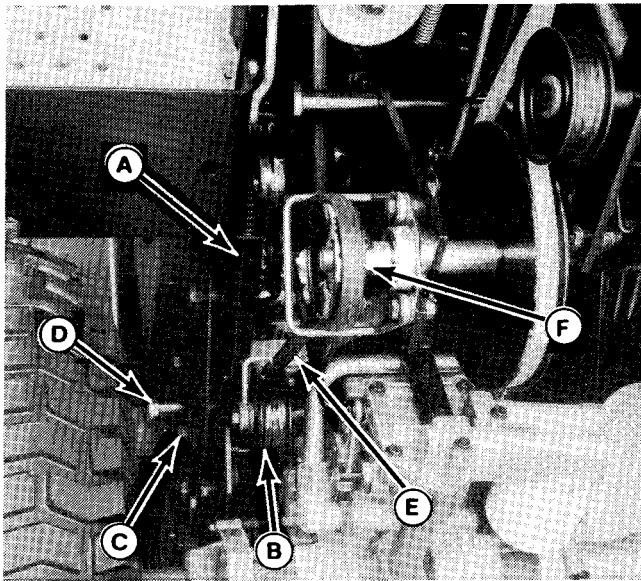

Figure 7.

- A. Clutch Rod
- B. Clutching Idler Pulley Assembly
- C. Bushing Assembly
- D. Pin
- E. Belt
- F. Jackshaft Pulley

6. Pull belt (A, Figure 8) through idler box assembly (B). Slide idler box over bolts and nuts (C) and secure to wrapper (D) with clevis pin (E) and spring clip (F).

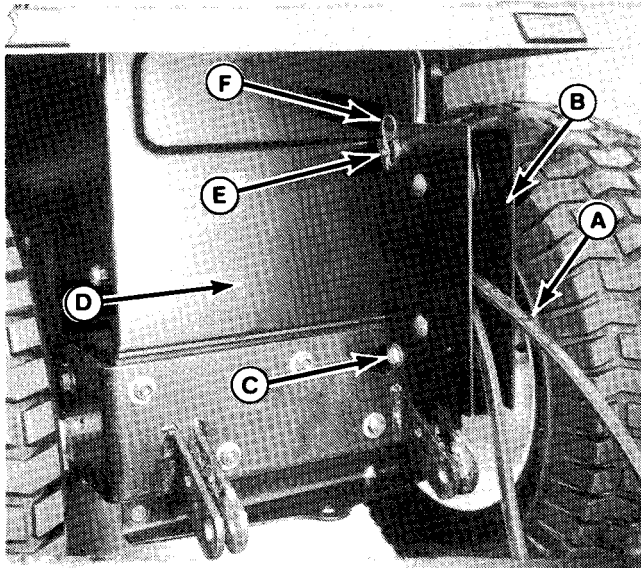

Figure 8.

- A. Belt
- B. Idler Box Assembly
- C. Bolts and Nuts
- D. Wrapper
- E. Clevis Pin
- F. Spring Clip

7. Back the tractor up to the front of the tiller. Align the two tiller mounting points with hitch points. Stop engine, remove key, and set the parking brake.
8. Install tiller to hitch and insert two large (round head) clevis pins (A, Figure 9). Secure with spring clips (B).

NOTE

If clevis pins (A) are too small, check for flat or round head. Larger (round head) pins may have been installed in jackshaft assembly bracket. Refer to step 2 (b) under "Tractor Setup".

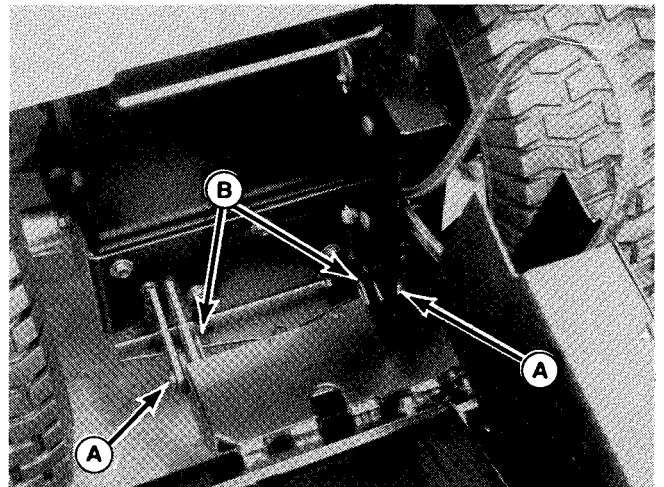

Figure 9.

- A. Clevis Pins
- B. Spring Clips

9. Remove wingscrew (A, Figure 10) and open tiller cover (B). Install belt (C) around tiller pulley (D). Close tiller cover and secure with wingscrew.

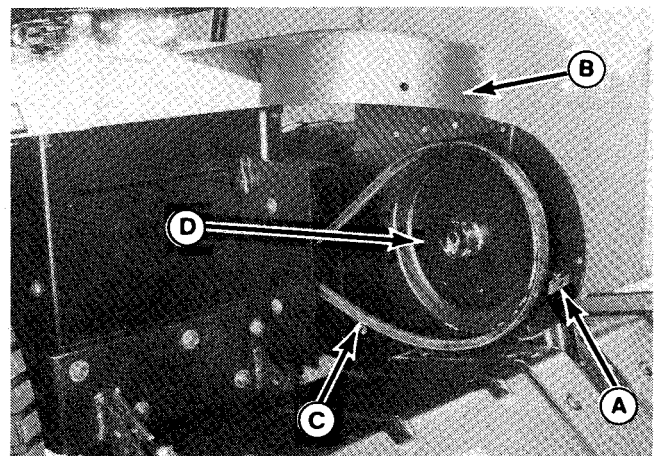

Figure 10.

- A. Wingscrew Location
- B. Tiller Cover
- C. Belt
- D. Pulley

10. Install support rod (A, Figure 11) to frame pin (B) and secure with spring clip (C).

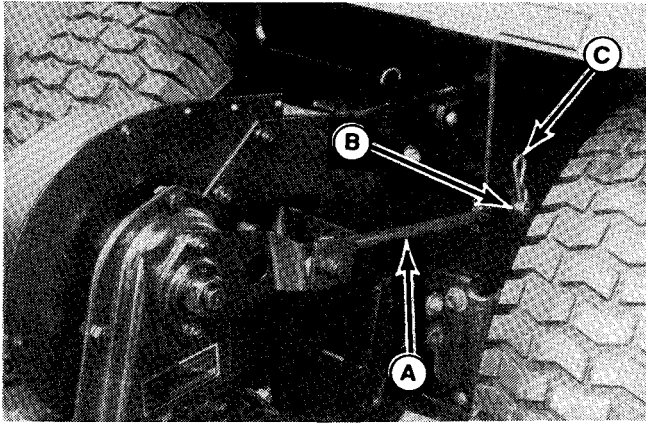

Figure 11.
 A. Support Rod
 B. Frame Pin
 C. Spring Clip

11. Install end of lift rod (A, Figure 12) through hole in the tractor lift lever (B). Secure with spring clip (C).

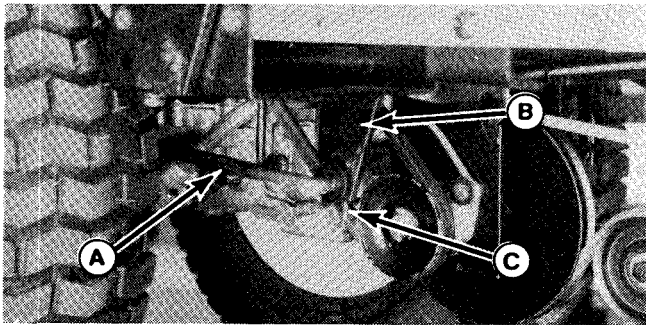

Figure 12.
 A. Lift Rod
 B. Lift Lever
 C. Spring Clip

12. Insert the opposite end of lift rod (A, Figure 13) through hole in tiller lift arm (B). Secure with spring clip (C).

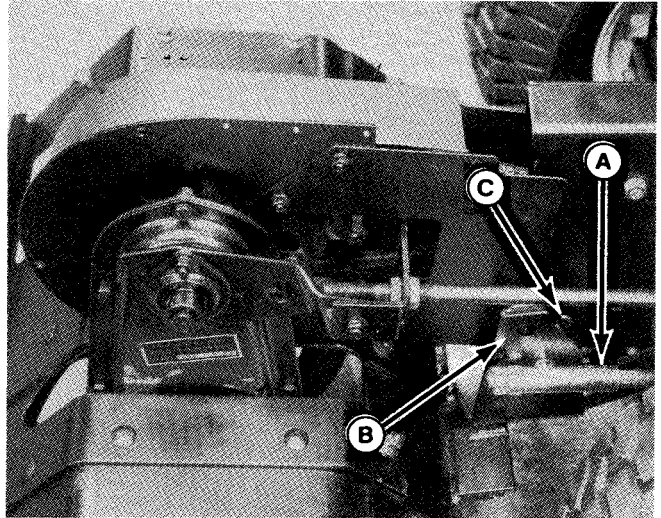

Figure 13.
 A. Lift Rod
 B. Lift Arm
 C. Spring Clip

13. Check position of belt pattern. Belts must be positioned on pulleys as shown in Figure 14.
 14. Check and, if necessary, adjust belt tension and lift rod. Refer to "Adjustments", page 8.

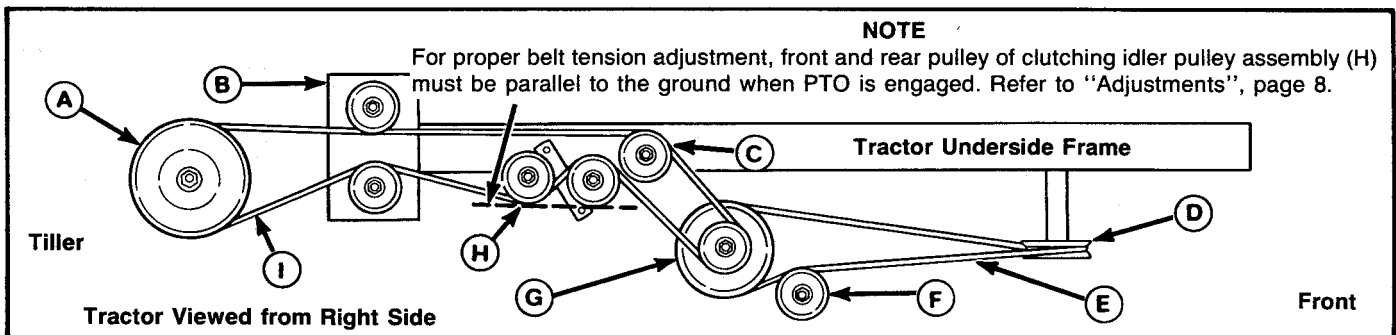

Figure 14.
 A. Tiller Pulley
 B. Idler Box Assembly
 C. Rear Idler Pulley
 D. Engine PTO Pulley
 E. PTO Drive Belt
 F. Tension Idler Pulley
 G. Jackshaft Pulley Assembly
 H. Clutching Idler Pulley Assembly
 I. Tiller Drive Belt

REMOVAL

1. Disengage tiller clutch by raising tractor PTO lever up. Lower tiller to the ground with lift lever.
2. Stop engine, remove key, and set the parking brake.
3. Remove spring clip (C, Figure 13) from lift rod (A). Remove rod from tiller lift arm (B).
4. Remove spring clip (C, Figure 12) from other end of lift rod (A). Remove rod from lift lever (B).
5. Remove spring clip (C, Figure 11) from pin (B) and remove support rod (A).
6. Remove wingscrew (A, Figure 10) and open tiller cover (B). Remove belt (C) from tiller pulley (D). Close cover and secure with wingscrew.
7. Remove spring clips (B, Figure 9) and remove clevis pins (A). Tiller is disengaged from hitch and tractor can be moved forward.
8. Remove spring clip (F, Figure 8) and clevis pin (E) from idler box assembly (B). Lift assembly off bolts and nuts (C) and pull forward to clear belt (A). Install pin and spring clip on assembly for storage.
9. Loosen nut on rear idler pulley and remove belt (E, Figure 7) from pulley and jackshaft pulley assembly (F). Retighten nut.
10. Remove clutching idler pulley assembly (B, Figure 7) from bushing assembly by removing spring clip and pin (D). With pulley assembly on ground, remove clutch rod (A) and spring clip. Reinstall spring clips for storage.
11. Spread belt guides (A, Figure 6) and remove belt (A, Figure 5) from drive pulley (C) and idler pulley. Leave belt attached to jackshaft assembly (B, Figure 4) for storage.
12. Remove jackshaft assembly as follows:
 - a. Remove PTO rod (F, Figure 4) from hole marked "MOW" on PTO arm (G).
 - b. Remove spring (E).
 - c. Unfasten spring clip and neutral return rod (A).
 - d. Remove spring clips and clevis pins (D) from rear of jackshaft bracket.
 - e. Slide jackshaft assembly (B) off front bracket bolts (C).
 - f. Slide jackshaft assembly (B) down to clear neutral return rod (A) and remove from tractor.
 - g. Reinstall neutral return rod (A) and spring clip.
 - h. Install clevis pins (D) and spring clips on jackshaft assembly for storage.
13. Other Tiller Kit components should be left installed on tractor.

Adjustments

WARNING

To avoid serious injury, perform adjustment only with tractor engine stopped. Remove the ignition key to prevent accidental starting.

BELT TENSION

1. Lower the tiller so that the tines rest on the ground.
2. Engage the tiller clutch by lowering tractor PTO arm down.
3. From right underside of tractor, examine clutching idler pulley assembly (A, Figure 15). Front (flat sided) pulley (B) and rear (grooved) pulley should be parallel to ground. Refer to "NOTE", Figure 14.

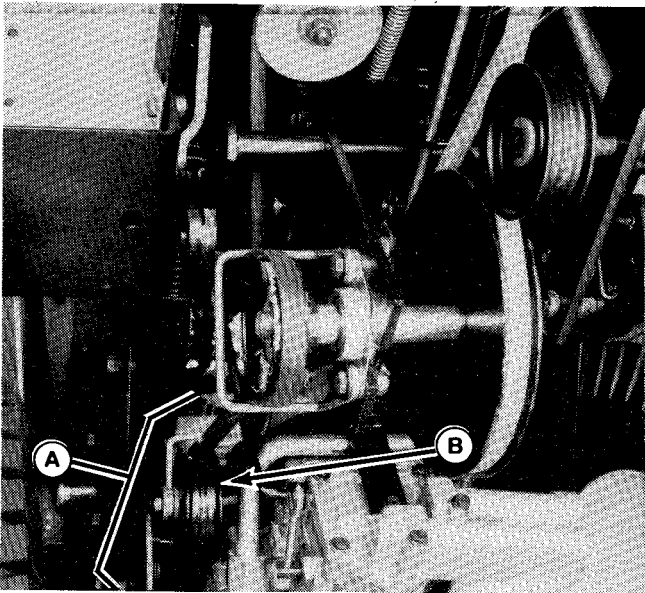

Figure 15.

- A. Clutching Idler Pulley Assembly
- B. Flat-Sided Pulley

4. If adjustment is required, loosen rear jamnut (A, Figure 16) on support rod (B). Standing at rear of tiller, turn front jamnut (C) clockwise (toward the ground) to raise the front pulley (B, Figure 15). Turn the jamnut counterclockwise to lower the front pulley. Retighten jamnuts.

LIFT ROD - Tilling Depth and Ground Clearance

Moving the jamnuts (A & B, Figure 17) affects the tilling depth and ground clearance. Moving the jamnuts toward the rear increases the tilling depth and decreases

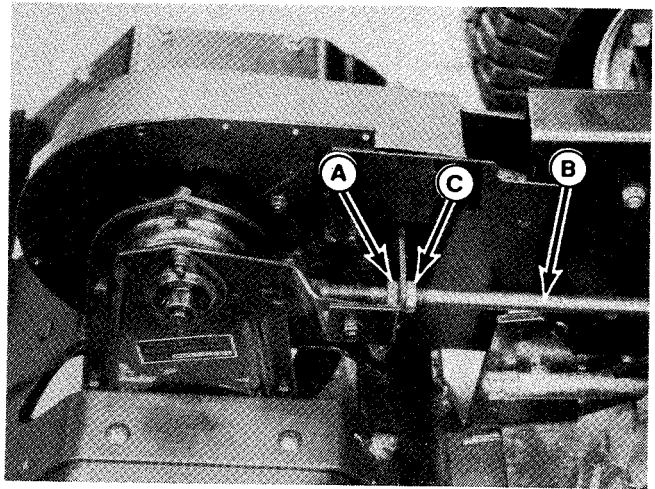

Figure 16.

- A. Rear Jamnut
- B. Support Rod
- C. Front Jamnut

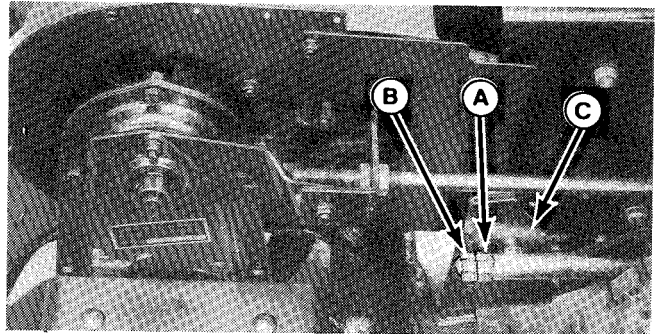

Figure 17.

- A. Front Jamnut
- B. Rear Jamnut
- C. Lift Arm

ground clearance. Moving the jamnuts toward the front decreases the tilling depth and increases the ground clearance. Initially, position the two nuts so that the lift arm (C) nearly touches the back of the tractor when the tiller is fully raised. If operation shows that greater tilling depth is needed, move the nuts toward the rear. To move the nuts, proceed as follows:

1. Lower the tiller so that the tines rest on the ground.
2. Hold forward jamnut (A) while loosening rear jamnut (B).
3. Move nuts to desired position on lift rod.
4. Hold forward jamnut (A) while tightening rear jamnut (B). The two nuts must be tight against each other.
5. Fully raise the tiller. Check to be sure that there is reasonable clearance between the ground and the tines.

Operation

CONTROLS

Figure 18 shows the location, name, and operation of the tiller controls.

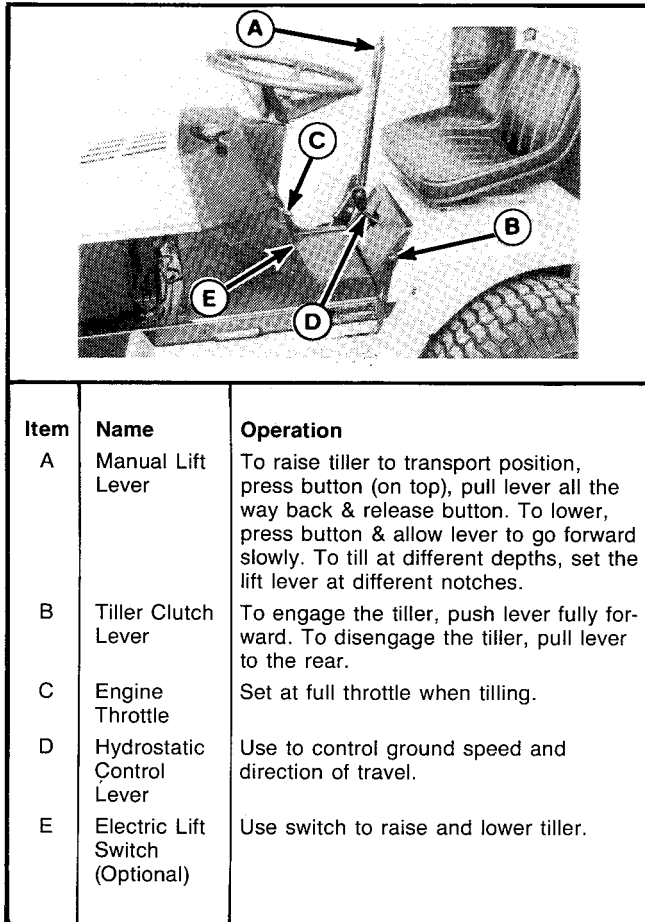

Figure 18. Controls



CAUTION

After striking a foreign object, stop the engine, disengage the PTO, and remove the key. Inspect the tiller for damage before starting.

CHECKS BEFORE STARTING

1. Make sure all covers and guards are in place. Make sure all nuts, bolts, pins, and clips are secure.
2. The tiller must be lubricated before first use and every four hours of operation. If required, see instructions in "Normal Care" section.
3. Clear the work area of any items that could be caught in the tiller.

TRANSPORTING

When transporting the tiller to and from the work area, the tiller should be fully raised and the tiller clutch lever should be fully rearward (disengaged). Adjust ground speed according to condition of the ground surface.

TURNING OR BACKING WHEN TILLING

Before backing up or turning, raise the tiller until it clears the ground. Otherwise, the tiller can be damaged.

The weight of the tiller will reduce the weight on the front tires. Front counterweights are recommended to restore normal turning ability.

ENGINE SPEED & GROUND SPEED

Tilling should always be done with engine speed at full throttle. Ground speed can be controlled with the hydrostatic control lever. If ground speed is too high, adjust the hydrostatic control lever, not the engine throttle. Refer to tractor "Operator's Manual" for more information on tractor operation.

OPERATION ON SLOPES

For your personal safety, always operate up and down the face of slopes, never across the face. Use slow ground speed. Use extreme caution when changing direction. Do not start or stop suddenly.

On slopes greater than 15 percent (8.5°) use a front counterweight. Never operate on slopes greater than 30 percent (16.7°) which is a rise of three feet in ten feet forward.

STARTING & STOPPING

To start tilling, engage the tiller clutch then lower the tiller. Slowly engage the hydrostatic control lever. The tiller will work into the soil. Engage the tiller clutch only when it is out of the ground.

To stop tilling, pull the clutch lever rearward. Raise the tiller into transport position.

TILLING SUGGESTIONS

Plan the pattern before beginning. When the land contour permits, it is best to travel in the longest direction to minimize turning.

The tiller will dig deeper with slow ground speed. It is best to increase the depth on succeeding passes until the desired depth is reached. Making passes crossways to the previous pass usually helps break sod into fine particles.

In soft, loose soil, it may be possible to till to desired depth in one pass.

Normal Care

LUBRICATION

Before first use and every four hours, lubricate the tiller as shown in Figure 19.

NORMAL STORAGE

Remove excess dirt and plant matter from the tiller and body. (This can be done with a hose.) Remove any twine or fibrous plant material still wound on tines. Store the tiller in an enclosed, dry area.

OFF-SEASON STORAGE (30 days or more)

1. Clean the entire tiller, including the tines.
2. Coat the tines with a light film of grease or oil. Coat all other bare metal surfaces with a good quality paint (obtainable from your dealer) or a light film of grease or oil.
3. Lubricate the tiller as shown in Figure 19.

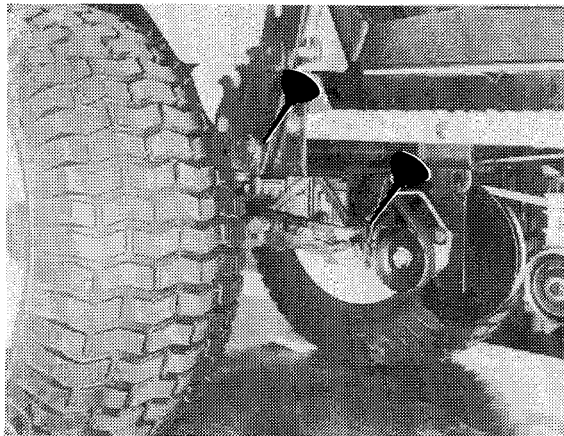

Front

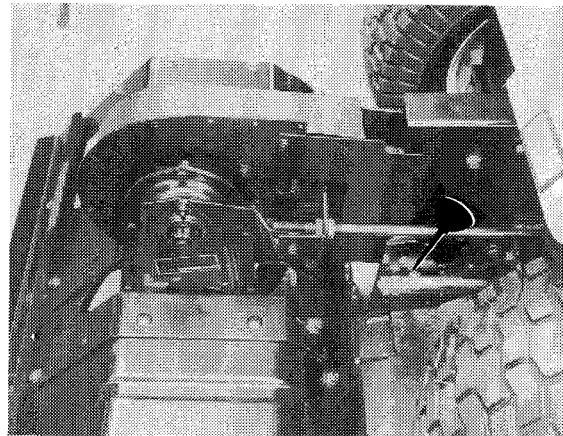

Rear

Lift Arm Lubrication

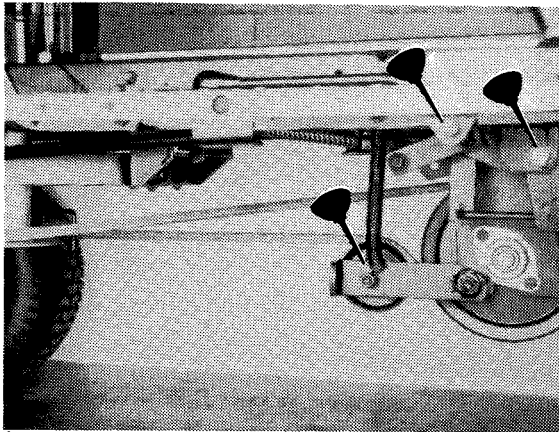

Jackshaft Idler Pulley

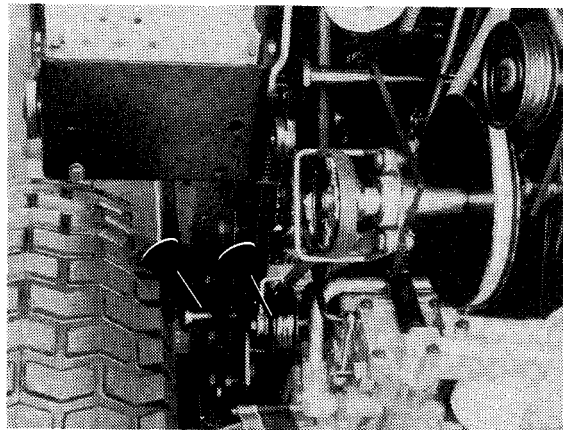

Clutching Idler Pulley Assembly

NOTE

Keep grease and oil off belts and pulleys.

Pulley Lubrication

Symbol	Use	Apply With	Procedure
	SAE 30 Oil	Oil Can	Clean indicated area and apply 2 or 3 drops of oil.

Figure 19. Lubrication (Every 4 Hours)

Troubleshooting and Service

TROUBLESHOOTING PROCEDURES

Troubleshooting procedures are provided in Figure 10. To use these procedures, first locate the problem description that best describes the trouble that you have encountered. Check the possible causes one at a time in the order that they are listed. Correct any problems that are found and try to operate the rotary tiller again to see if you have eliminated the trouble.



WARNING

For your safety, do not try to adjust or repair the tractor or rotary tiller while the engine is running. Also, always remove the key from the ignition switch before beginning the maintenance to prevent accidental starting of the engine.

Problem	Cause/Remedy
<p>1. Rotary tiller tines do not rotate.</p>	<p>A. Tiller clutch not engaged. Push clutch fully forward. B. Tiller drive belt too loose. Adjust belt tension. C. Rock jammed in tiller. Remove it. D. Tiller drive belt broken. Replace as needed. E. Drive belt or pulleys oily. Clean as required.</p>
<p>2. Tills too shallow.</p>	<p>A. Tiller raised too high. Lower it using tractor lift. B. Engine speed too low. Set engine to full speed. C. Tractor speed too fast. Adjust transmission control lever for slower speed. D. Ground too hard. Make several passes, tilling deeper on each pass.</p>
<p>3. Tiller leaves ground rough with large clods.</p>	<p>A. Ground too wet. Wait until sod does not ball up when rolled in your hand. B. Tilling too deep at one pass. C. Tractor speed too fast. Adjust transmission control lever for slower speed.</p>
<p>4. Tractor handles poorly.</p>	<p>A. Tractor speed too fast. Use slower speed, especially when running on rough or sloping surfaces. B. Front wheels lifting. Clean dirt from tiller. Use front wheel counterweights. C. Rear wheels slip. Use chains or wheel weights, or wait for dry conditions. D. Tiller propels tractor. See causes for problem 3 above.</p>

TINE REPLACEMENT

When required because of wear or breakage, replace a tine as follows:

1. Remove two capscrews (A, Figure 20) and locknuts (B).
2. Remove old tine (C) from tiller.
3. Place new tine on mounting plate (D). When facing front of tiller, be sure tine curves away from mounting plate with its sharp edge facing rearward when tine nears bottom of travel.
4. Insert two capscrews (A) through tine and then through mounting plate. Install and tighten locknuts (B) to a torque of 30 foot-pounds (40 N.m).

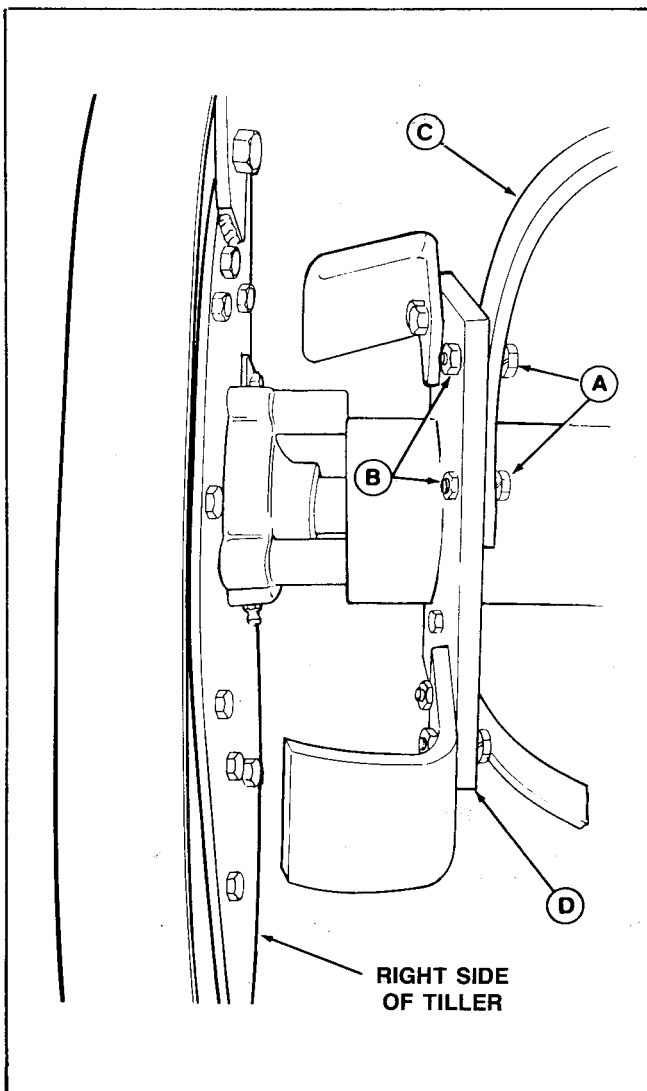

Figure 20. Tine Replacement

- A. Capscrews
- B. Locknuts
- C. Tine
- D. Mounting Plate

TILLER DRIVE BELT REPLACEMENT

1. Remove wingscrew (A, Figure 21) and open tiller cover (B). Remove belt (C) from tiller pulley (D).

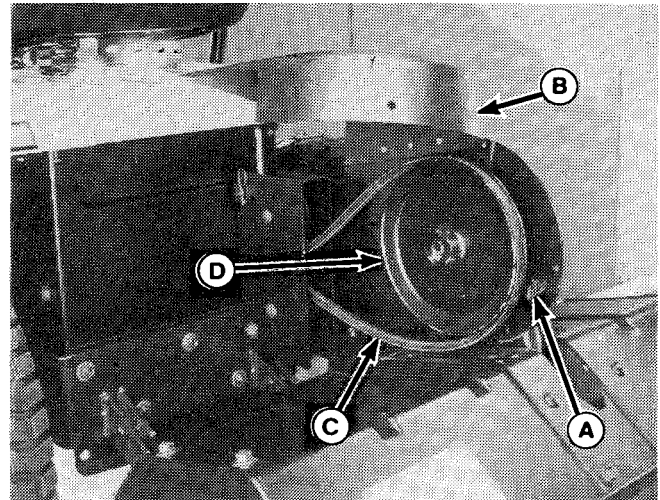

Figure 21.

- A. Wingscrew Location
- B. Tiller Cover
- C. Belt
- D. Pulley

2. Loosen nut (A, Figure 22) on rear idler pulley (B) and remove tiller belt from pulley.

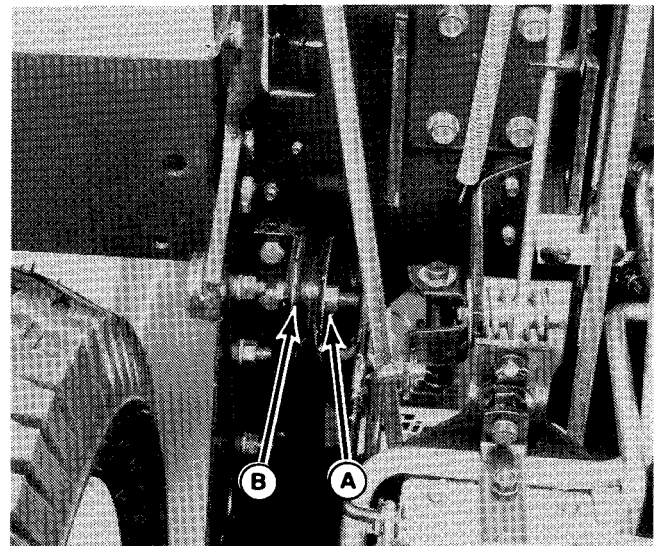

Figure 22.

- A. Nut
- B. Idler Pulley

3. Remove clutching idler pulley assembly (A, Figure 23) from bushing assembly (B) by removing spring clips and pin (C). With pulley assembly on ground, remove clutch rod (D) and spring clip.

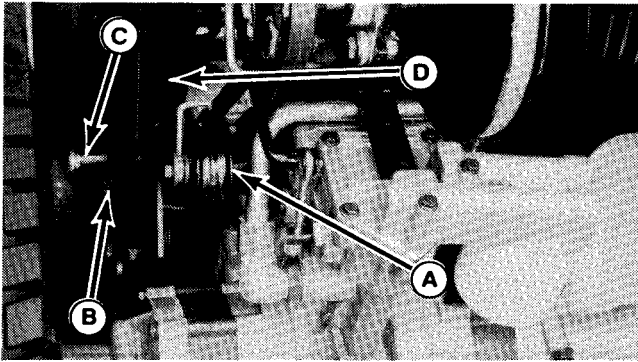

Figure 23.

- A. Clutching Idler Pulley Assembly
- B. Bushing Assembly
- C. Pin
- D. Clutch Rod

4. Loosen belt guides (A, Figure 24) and remove old belt (if necessary). Install new belt so that grooved side of belt faces the grooved pulley (B) and the flat side of belt runs along the top of the flat-sided pulley (C). Tighten belt guides (A) so they are at a 90° angle to pulley bracket (D).

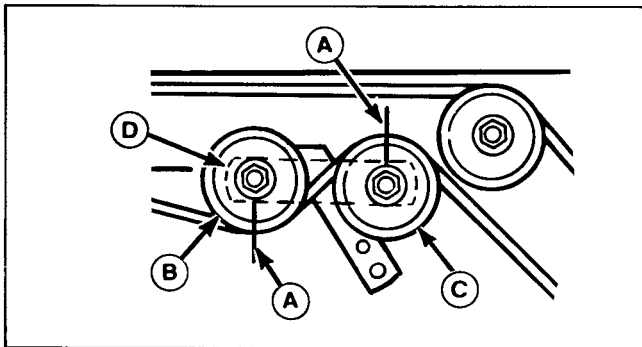

Figure 24.

- A. Belt Guide
- B. Grooved Pulley
- C. Flat-Sided Pulley
- D. Bracket

5. Reinstall clutch rod (D) and spring clip. Install clutching idler pulley (A, Figure 23) to bushing assembly (B) and secure with pin (C) and spring clip.
6. Pull belt (A, Figure 25) through idler box assembly (B) and install on tiller pulley (D, Figure 21). Close tiller cover and secure with wingscrew (A, Figure 21).
7. Reinstall tiller belt on pulley (A, figure 22) and tighten nut.
8. Install belt on jackshaft pulley.
9. Check position of belt pattern. Belts must be positioned on pulleys as shown in Figure 14.
10. Adjust belt tension. Refer to "Adjustments" section, page 8.

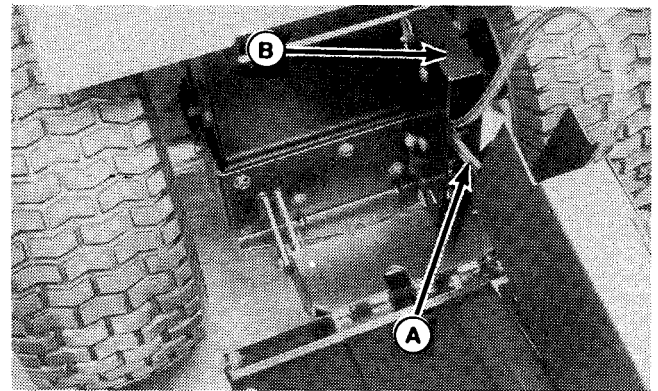

Figure 25.

- A. Belt
- B. Idler Box Assembly

PTO BELT REPLACEMENT

1. Remove belt (A, Figure 26) from jackshaft idler pulley (B).

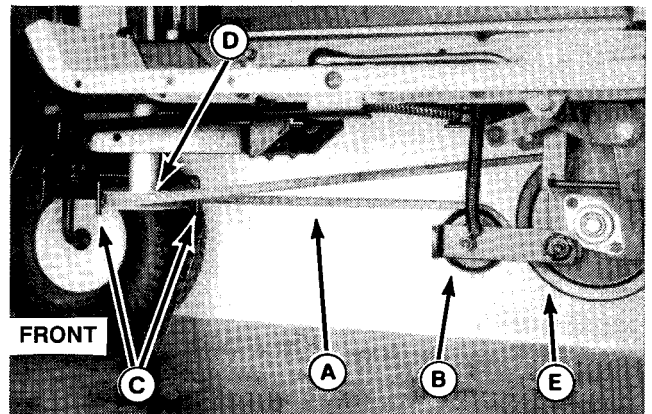

Figure 26.

- A. Belt
- B. Jackshaft Idler Pulley
- C. Belt Guides
- D. Drive Pulley
- E. Large Jackshaft Pulley

2. Move belt guides (C) away from drive pulley (D) and remove belt.
3. Remove belt from large jackshaft pulley (E).
4. Install new belt on jackshaft pulley (E) and drive pulley (D). Turn belt by hand so that higher portion of belt is on left side of tractor.
5. Position belt guides (C) so there is a 1/16" space between the belt and guides. Refer to Figure 6. Tighten guides.
6. Make sure belt is positioned as shown in Figure 26.

Tractor Setup

ATTENTION SETUP PERSONNEL

As setup personnel you have an obligation to know the product better than the customer. This includes safety related items. Prior to actual setup, thoroughly familiarize yourself with the Operator's Manual. Pay special attention to all safety warnings. It is possible during setup to place yourself in a position which is more hazardous than when the unit is in operation. Remember, it is your responsibility to set up the product safely and to know it well enough to be able to instruct a customer in the safe use of his power unit.

Safety is a matter of common sense . . . A matter of thinking before acting. Most shops have specific safety practices. Follow them. The precautions listed in the Operator's Manual should not supersede existing practices but should be considered as supplemental information.

1. Prior to tiller installation, tractor must be equipped with the Hitch and Lift Rod Kit (A and B, Figure 27). Refer to Hitch Kit instructions for setup procedures.

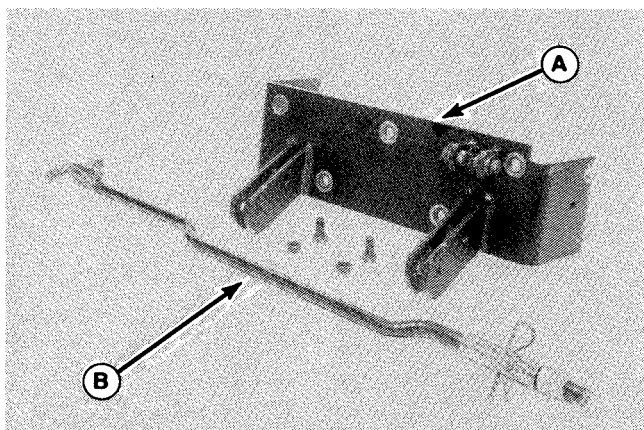

Figure 27.

- A. Tiller Hitch
- B. Lift Rod

2. Make sure that the knockout panel (A, Figure 28) had been removed from the wrapper (B). Tapping top and bottom of panel with a hammer and punch will remove panel.

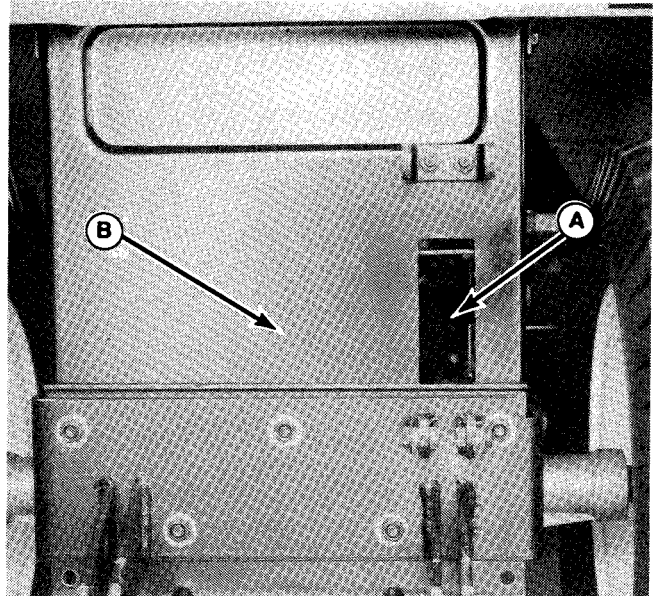

Figure 28.

- A. Knockout Panel (shown removed)
- B. Wrapper

3. Open seat deck to expose battery compartment. Remove battery holddown rods (A, figure 29). Slide battery (B) to the left side of tractor.

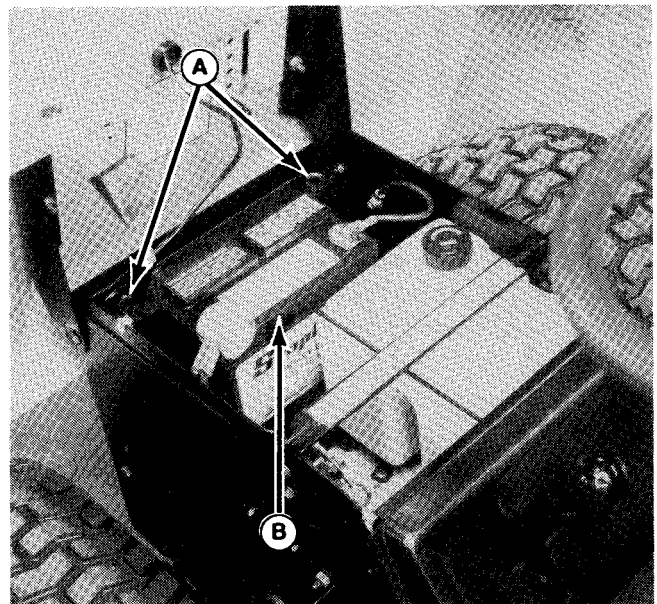

Figure 29.

- A. Holddown Rod
- B. Battery

4. Install idler box bracket (A, Figure 30) to wrapper (B). Install bolts from inside of wrapper and secure with nuts (C). Secure battery again.

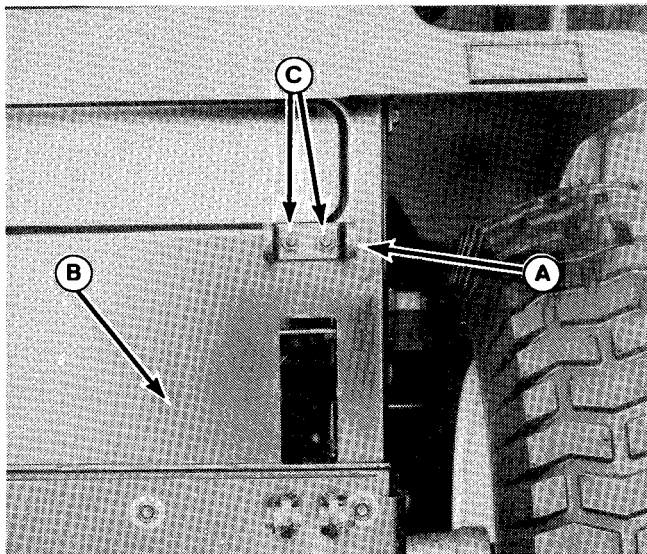

Figure 30.
A. Idler Box Bracket
B. Wrapper
C. Nuts

5. Install jackshaft bracket (A, Figure 31) between drive pulley spring (B) and frame. Make sure that notched end is positioned toward the front of the tractor. Secure with four bolts (C) to tractor frame.

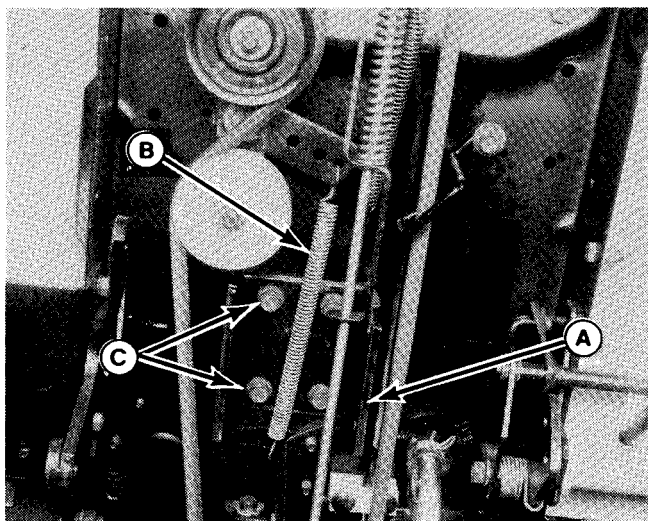

Figure 31.
A. Jackshaft Bracket
B. Pulley Spring
C. Bolts

6. With seat deck raised, install idler pulley bracket (A, Figure 32) to underside of tractor frame. Pulley must face towards the inside and front of tractor. Install two bolts (B) from the underside and secure with nuts under seat deck.

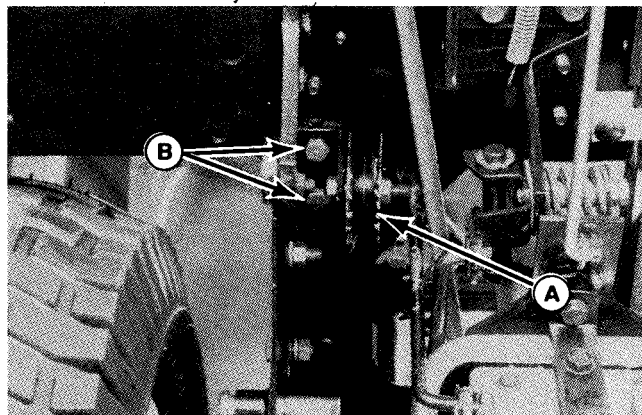

Figure 32.
A. Idler Pulley Bracket
B. Bolts

7. Install bushing assembly as follows:
 - a. Remove bolt and nut (A, Figure 33) from round (top) hole in wrapper.
 - b. Slide pin (B) into bushing assembly (C).
 - c. Position bushing assembly and pin between wheel and wrapper so that pin will stick through wrapper towards underside of tractor.
 - d. Install square neck bolt (D) from underside of tractor and secure with nut on outside of wrapper.
 - e. Reinstall removed bolt and nut (A) in round (top) hole.

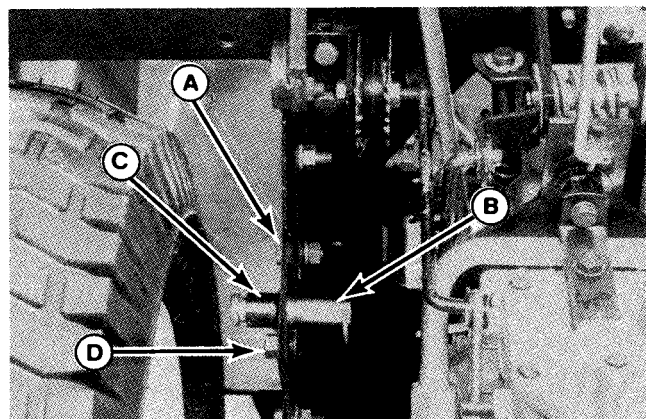

Figure 33.
A. Round Bolt and Nut
B. Pin
C. Bushing Assembly
D. Square Bolt and Nut

8. Remove bolt and nut and install pin and washer (A, Figure 34) from outside of wrapper. Secure with lockwasher and nut through knockout panel hole (B). Insert spring clip (C) and tighten nut.

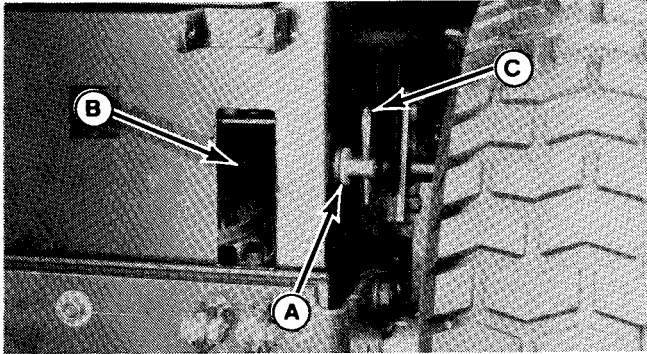

Figure 34.

- A. Pin and Washer
- B. Panel Hole
- C. Spring Clip

NOTE

Spring clip (C) and hole must face up and down (as shown in Figure 34) to accept lift arm.

9. Remove cotter pin holding neutral return rod (A, Figure 35) and washer to bracket (B). Discard washer and cotter pin. Install bottom nut (C) onto pin (D)

and insert pin from bottom into bracket (B). Secure with nut on top of bracket. Reinstall rod and secure with spring clip.

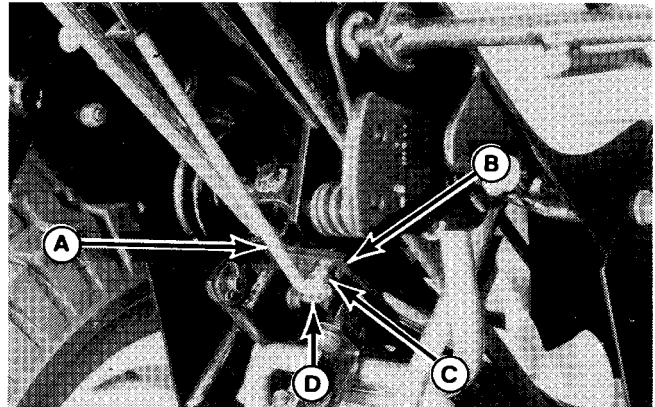

Figure 35.

- A. Neutral Return Rod
- B. Bracket
- C. Bottom Nut
- D. Pin

NOTE

Pin (D) must be turned parallel with rod (A) before tightening top nut on bracket. Rod will be turned 90° from previous position when reinstalled.

Specifications

DIMENSIONS

Tilling Depth: 6 Inches (152 mm) Maximum
Effective Width: 30 Inches (762 mm)
Overall Width: 32 Inches (813 mm)
Overall Length: 17 Inches (432 mm) – without drive & hitch included
Overall Height: 22.5 Inches (572 mm)
Transport Ground Clearance: 4 Inches (102 mm) Maximum
Approximate Weight: 132 Pounds (60 kg)

CONTROLS

Tilling Depth: Adjustable
Lift: Tractor Rear Lift System
Engagement: Clutching V-belt Operated by Tractor PTO Control Handle

DRIVE TRAIN

Clutch: V-Belt, Spring Tensioned Idler
Input Drive: Cushioning V-Belt from Tractor
Final Drive: Roller Chain

CHASSIS

Hitch: Welded Steel
Bearings: Rolling Contact
Housing: Stamped Steel
Number of Tines: 16 Replaceable Tines

Free Manuals Download Website

<http://myh66.com>

<http://usermanuals.us>

<http://www.somanuals.com>

<http://www.4manuals.cc>

<http://www.manual-lib.com>

<http://www.404manual.com>

<http://www.luxmanual.com>

<http://aubethermostatmanual.com>

Golf course search by state

<http://golfingnear.com>

Email search by domain

<http://emailbydomain.com>

Auto manuals search

<http://auto.somanuals.com>

TV manuals search

<http://tv.somanuals.com>