

SNAPPER TRACTOR

48" ROTARY TILLER

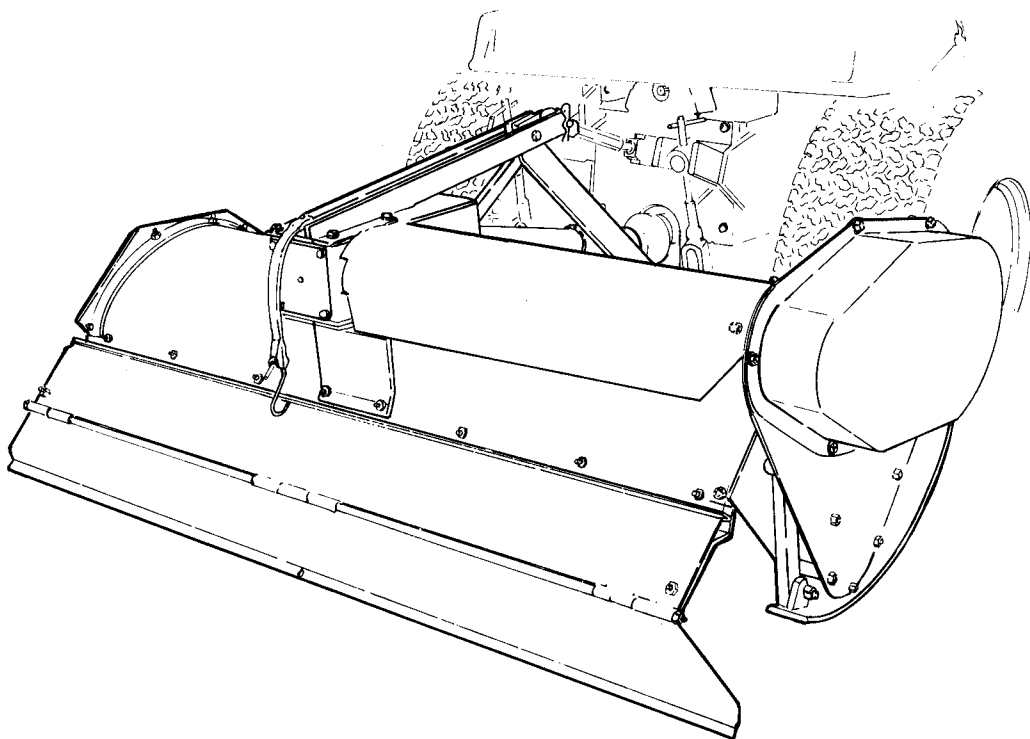

ATTACHMENT #8-0899

This 48" Rotary Tiller is designed for use with Snapper Tractors equipped with rear power take-off and three point hitch. Read

this manual carefully before attaching the tiller to the tractor and keep the manual for future reference.

McDonough Power Equipment
McDonough, GA • 30253





SAFETY PRECAUTIONS



Safety Shields are usually removed for access to assemblies being serviced and sometimes for photographic purposes (clarity of Figure). All safety shields must be replaced after servicing. Also replace any Caution, Warning or Instruction Decal that it not readable or missing.

Read this Manual and Tractor Manual carefully before operating unit. Give special attention to all safety suggestions. They are included for your protection.

- Know tractor controls and how to stop quickly. READ THE TILLER AND TRACTOR OPERATOR'S MANUALS.
- Do not allow children to operate unit. Do not allow adults to operate unit without proper instructions.
- Do not carry passengers. Keep children and pets a safe distance away.
- Clean work area of objects which might be picked up and thrown causing personal injury or equipment damage.
- Disengage power to Tiller, shut off tractor engine before making any repairs or adjustments.
- Keep all safety shields in place.
- Keep hands, feet and clothing away from moving parts.
- Do not operate Tiller on steep hillsides.
- Tiller should be disengaged, tractor engine shut off and inspect for damages after striking foreign object. Damage should be repaired before restarting and operating.
- Disengage power to Tiller, shut off tractor engine before unclogging Tiller tines.
- If Tiller must be in raised position when making adjustments, block it up securely.
- Check all nuts and bolts, particularly tine hardware at frequent intervals.



PERSONAL INJURY MAY RESULT IF THESE PRECAUTIONS ARE NOT FOLLOWED.



Subject	Page(s)	Subject	Page(s)
SAFETY PRECAUTIONS	Above	LUBRICATING TILLER	7
SPECIFICATIONS	3	DETACHING TILLER	7
PREPARATION	3 - 4	MAINTENANCE & ADJUSTMENTS	8 - 11
TRACTOR P.T.O. SHIELD	3	REPLACING OUTER CHAIN DRIVE	8
ATTACHING TILLER	3 - 4	ADJUSTING ENCLOSED DRIVE CHAIN	8
LEVELING TILLER	5	ADJUSTING TORQUE LIMITER	9
OPERATION	6	TINE SHAFT AND BEARINGS (LEFT)	9 - 11
TROUBLE SHOOTING GUIDE	6	TINE SHAFT AND BEARINGS (RIGHT)	11
		TILLER WARRANTY	12

GENERAL SPECIFICATIONS

Tilling Width	48"
Overall Width	59"
Number of Tines	24
Tilling Depth	Up to 8"
Drive	Tractor rear PTO
Tine Material	High carbon heat treated steel
Tine Speed	200 rpm at 2000 PTO speed
Weight	320 lbs.
Shipping Weight	375 lbs.
Tine Retaining Bolt Torque	50-55 ft.-lbs.

NOTE: Reference to left-hand and right-hand used throughout Manual refers to a position behind Tiller facing forward.

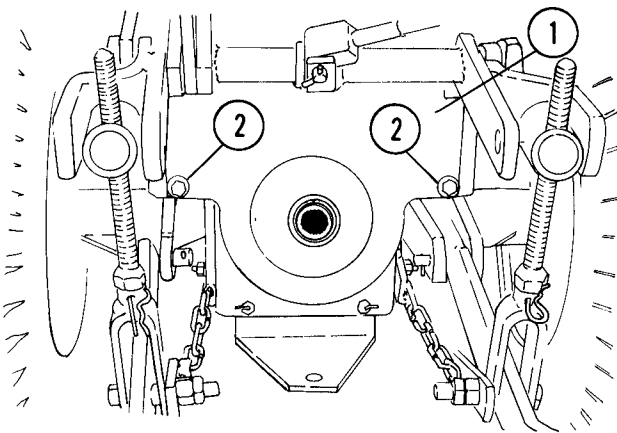

Fig. 1 — Rear Cover Assembly

- 1. Cover
- 2. Lower Retaining Bolts

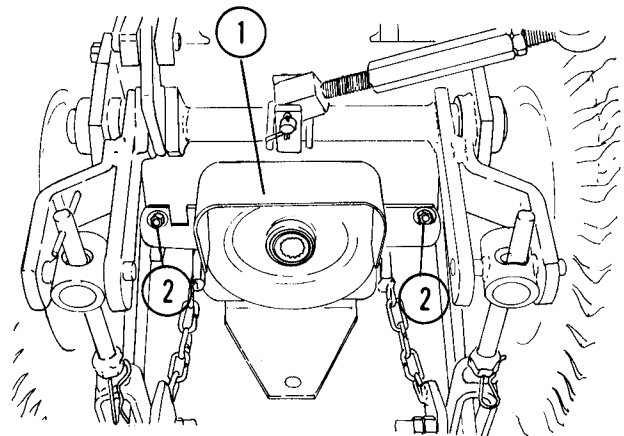

Fig. 2 — Rear PTO Shield Installed

- 1. PTO Shield
- 2. New Bolts Installed

TRACTOR & TILLER PREPARATION

TRACTOR PTO SHIELD

If not previously installed for some other accessory, the PTO shield kit, Snapper No. 6-0393, must be installed to the Tractor rear PTO cover.

1. Remove and discard two lower bolts from tractor rear PTO cover as shown in Figure 1.

2. Install PTO shield as shown in Figure 2, using two new bolts provided with PTO shield kit.

ATTACHING TILLER

1. Before attaching Tiller to tractor, position Tiller on level area and "BLOCK" up front of Tiller so that "A" frame is vertical as viewed from side, Figure 3.

2. Remove breather/fill plug as shown in Figure 4.

3. Fill gearbox with Specification EP 90 gear and axle oil until oil seeps out of oil level plug hole and then replace both plugs.

4. Position tractor lift arm check chains in front hole as shown in Figure 5.

5. Start tractor engine as outlined in the the Tractor Operator's Manual.



Look for this symbol to point out important safety precautions. It means — **ATTENTION! BECOME ALERT! YOUR SAFETY IS INVOLVED.**

CONTINUED

ATTACHING TILLER (CONTINUED)

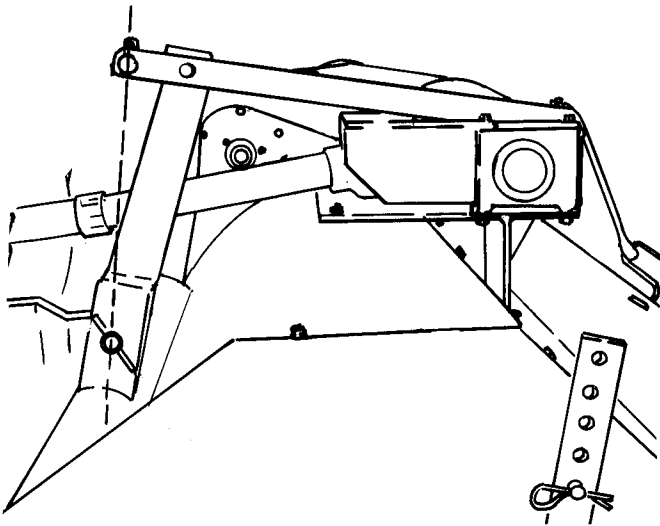

Fig. 3 — Level Tiller

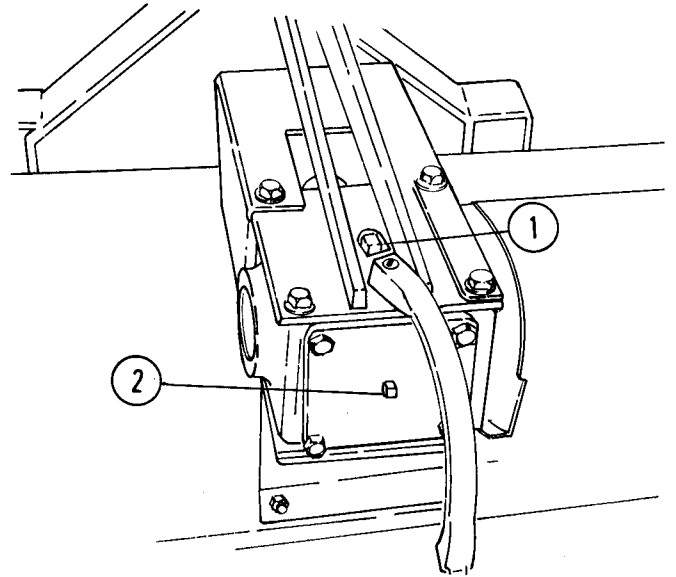

Fig. 4 — Filling Gearbox

1. Filler Plug
2. Oil Level Plug



CAUTION: Do not move tractor if anyone is between tractor and Tiller or behind Tiller. Do not reach back to align hitch points.

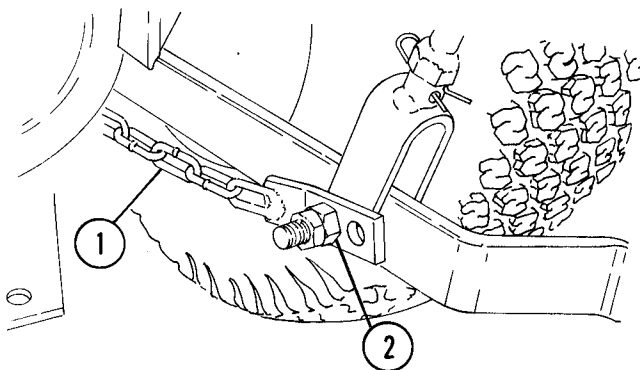

Fig. 5 — Check Chains

1. Check Chain
2. Front Hole Position

6. Back tractor slowly to Tiller until tractor lower lift arms are aligned with lower hitch points on tiller "A" frame.

7. Make sure all tractor controls are in "Neutral" or in "Off", set parking brake and shut off engine.

8. Attach tractor left and right lift arms to Tiller and secure with hairpins as shown in Figure 6.

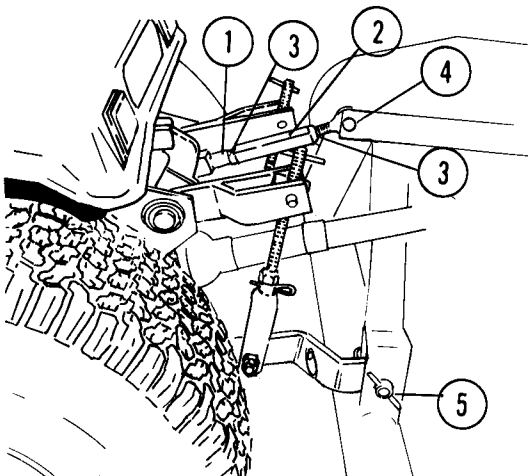

Fig. 6 — Attaching Tiller

1. Top Link
2. Adjuster Barrel
3. Jam Nuts
4. Top Hitch Point
5. Lower Hitch Points

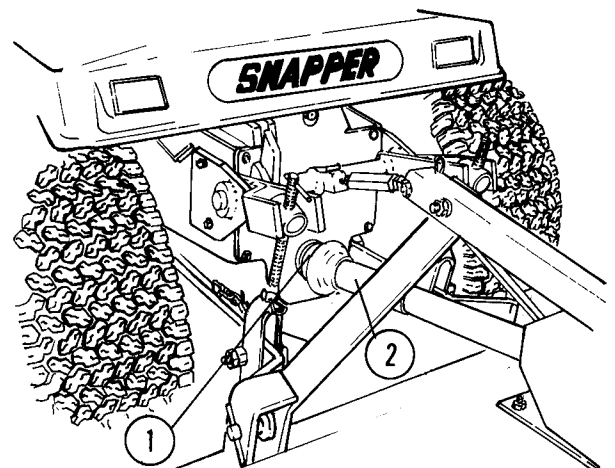

Fig. 7 — PTO Shaft

1. Lock Ring
2. PTO Shaft

9. Adjust length of tractor top link and attach to top hitch point on Tiller "A" frame, Figure 6.

10. Slide front portion of PTO drive shaft onto rear portion and then slide PTO drive shaft splined end into tractor, Figure 7.



CAUTION: Make sure PTO lock ring snaps into place, Figure 7.

LEVELLING TILLER

IMPORTANT: A transport height above 17" (measured from lower lift arm hitch pin hole to ground) will cause an undesirable PTO angle resulting in exces-

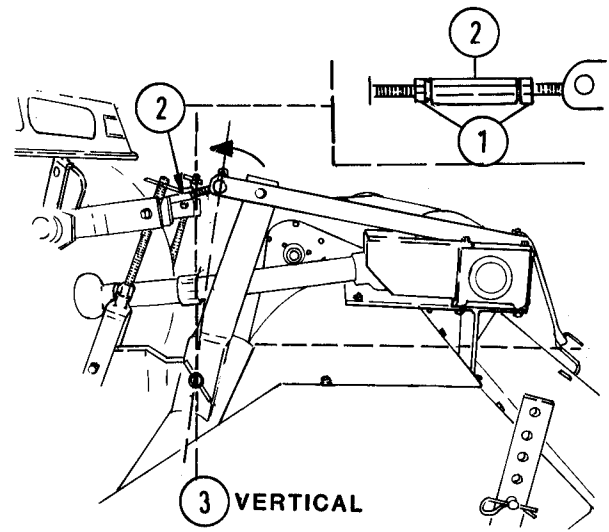

Fig. 9 — Levelling Tiller

1. Jam Nuts
2. Top Link Adjuster Barrel
3. Level Tiller

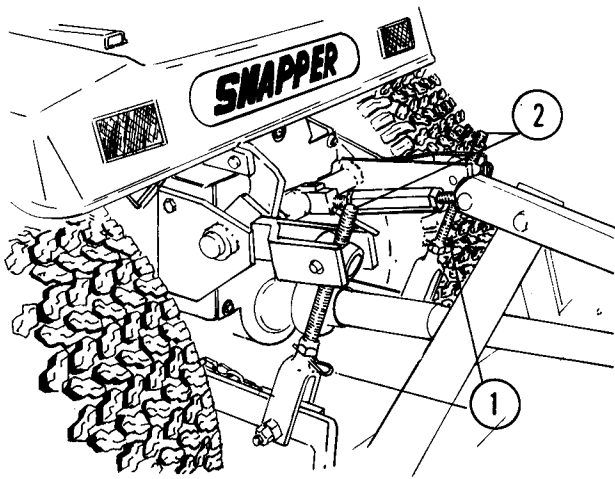

Fig. 8 — Lift Link Adjustment

1. Hairpins
2. Lift Link Adjusters

sive noise due to vibration of sliding PTO shield. Remove hairpins and adjust lift links until this measurement is achieved, Figure 8. Replace locking hairpins.

With tractor and Tiller on a level surface, Tiller is longitudinally level when "A" frame is vertical as viewed from the side.

If "A" frame is not vertical, loosen jam nuts on top link and lengthen or shorten as necessary to achieve vertical as shown in Figure 9.



CAUTION: Be sure to lock jam nuts on top link to prevent unintentional rotation of turnbuckle barrel.

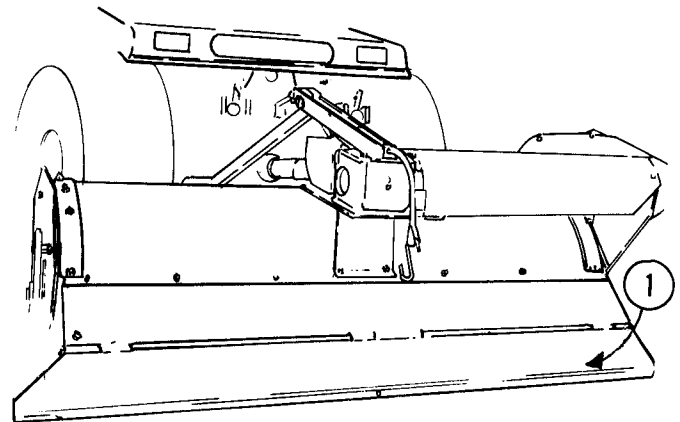

Fig. 10 — Level Blade

1. Level Blade Lowered

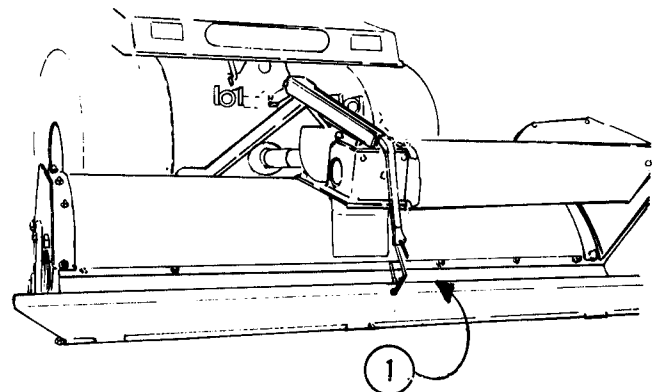

Fig. 11 — Level Blade

1. Level Blade Raised

OPERATION

Before operating Tiller, always check area to be worked. Do not run over large stones, pipes, or other heavy obstructions which could damage Tiller.



CAUTION: Never adjust or work on Tiller with tractor engine running. Although Tiller will not normally throw objects, keep persons and pets from directly behind when it is in operation. Always make certain level blade is lowered when Tiller is being operated in rocky conditions.

NOTE: Do not try to operate Tiller in long grass or high weeds. Cut and remove this material before tilling. Do not operate Tiller when soil is wet.

1. Raise or lower Tiller with tractor auxiliary hydraulic control lever.
2. To engage Tiller move tractor rear PTO control lever to "On" position.
3. Depress tractor neutral return brake pedal, place rear axle shift lever in "Low" range and speed control lever to No. 1 speed range.
4. Advance throttle to "Fast" position and lower Tiller slowly with auxiliary hydraulic control lever to engage soil.
5. Release neutral return brake pedal and slowly push down with toe on forward/reverse pedal
6. Always raise Tiller when turning or when backing tractor.
7. Lower level blade when tilling to produce a finer and smoother seed bed, Figure 10. For coarse bed or when cultivating, move level blade all the way up, Figure 11.
8. Recommended forward speed for tilling is 0.5 mph.
9. If Tiller should encounter a heavy obstruction, stop tractor immediately and disengage Tiller drive. Should a large accumulation of heavy vines or weeds wrap around tines or shaft, turn off tractor engine and remove this material before proceeding.
10. If tractor is to be stopped for any length of time, with Tiller in working position, quickly disengage drive or raise machine out of ground or its working motion will create a hole after a few seconds of stationary operation.

TROUBLE-SHOOTING GUIDE

PROBLEM	PROBABLE CAUSE	POSSIBLE REMEDY
TINES DO NOT ROTATE	<ol style="list-style-type: none"> 1. Material wrapped around tine shaft. 2. Drive chains slipping. 3. Torque limiter slipping excessively. 4. Outer drive chain jumping sprockets. 	<ol style="list-style-type: none"> 1. Clean and free-up shaft. 2. Readjust chain tension (See Page 7) 3. Readjust limiter (See Page 9) 4. Check tension adjustment (See Page 8)
TINES DO NOT DIG	<ol style="list-style-type: none"> 1. One or more tines reversed. 	<ol style="list-style-type: none"> 1. Correct installation of tines. Cutting edges must be toward direction of rotation.
TINES WILL NOT CLEAR GROUND IN RAISED POSITION	<ol style="list-style-type: none"> 1. Excessive weight due to build-up of soil and plant material. 	<ol style="list-style-type: none"> 1. Thoroughly remove material inside shroud and around tine assembly.
TILLER CLIMBS OUT OF GROUND	<ol style="list-style-type: none"> 1. Forward speed too high. 2. Attempting to till too deep on first pass over hard ground. 	<ol style="list-style-type: none"> 1. Reduce tractor ground speed. 2. Make shallow cut first, then successive deeper passes by adjusting tractor control lever.

LUBRICATION

Oil leveller blade hinges daily with engine oil.

Periodically remove oil level plug at rear of gearbox to check oil level. If filling is necessary, remove breather plug and fill with Specification EP 90 gear and axle oil until it seeps out level hole. Reinstall plugs, Figure 12.

Annually, or at end of each working season, remove external chain and clean thoroughly with cleaning solvent or diesel fuel. Submerge chain in clean engine oil. Remove excessive oil before reinstalling on Tiller. See "Servicing" Section.

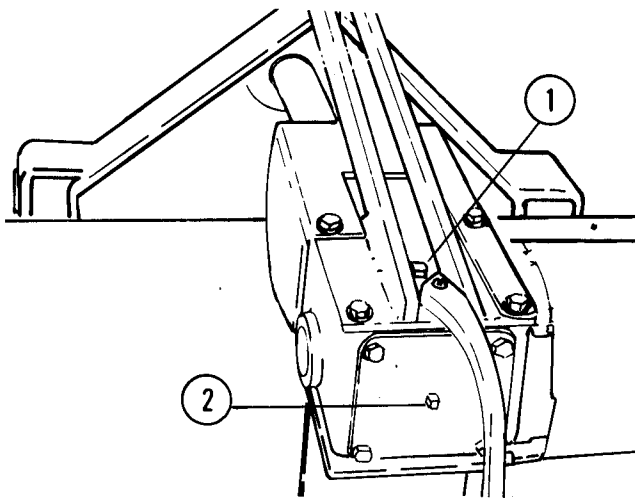

Fig. 12 — Gearbox Lubrication

1. Filler Plug
2. Level Plug

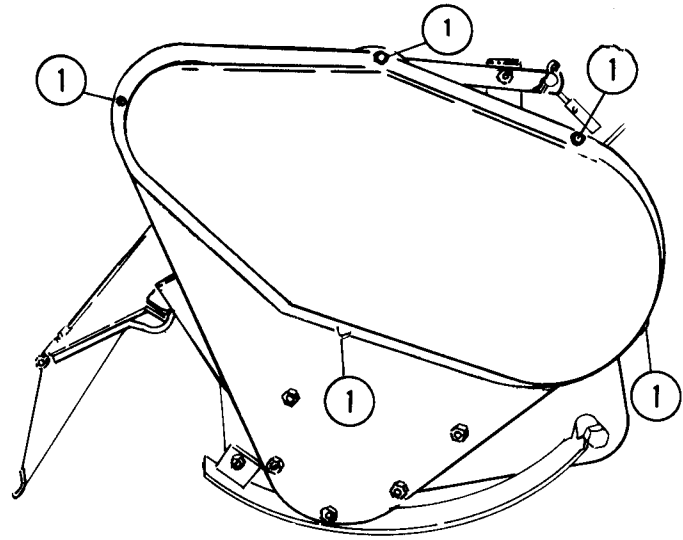

Fig. 13 — Outer Chain Guard

1. Retaining Bolts

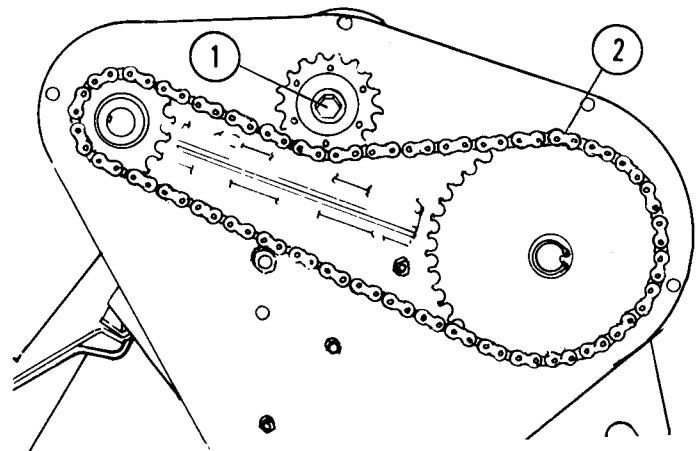

Fig. 14 — Outer Drive Chain

1. Idler Sprocket
2. Master Link

DETACHING TILLER



CAUTION: Before detaching Tiller, it is recommended support blocks be placed under front and rear of Tiller to prevent Tiller from tipping over. Also, disconnect PTO at the Tractor.

1. Lower Tiller onto blocks.
2. Disconnect Tiller PTO drive line at the Tractor.
3. Detach tractor top link from Tiller.
4. Detach tractor right lift arm, then left lift arm from Tiller.
5. Drive tractor slowly away.

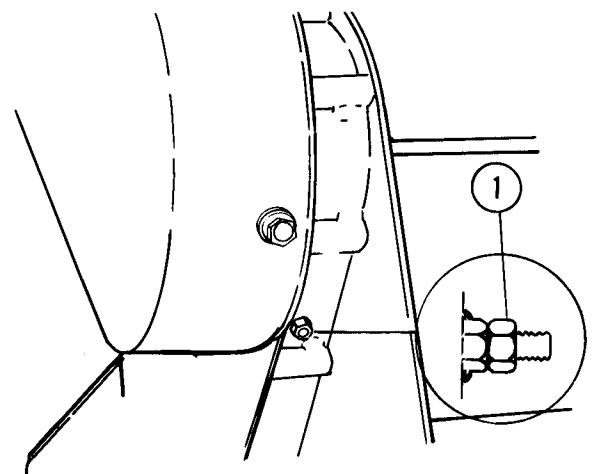

Fig. 15 — Enclosed Drive Chain

1. Adjuster

MAINTENANCE & ADJUSTMENTS

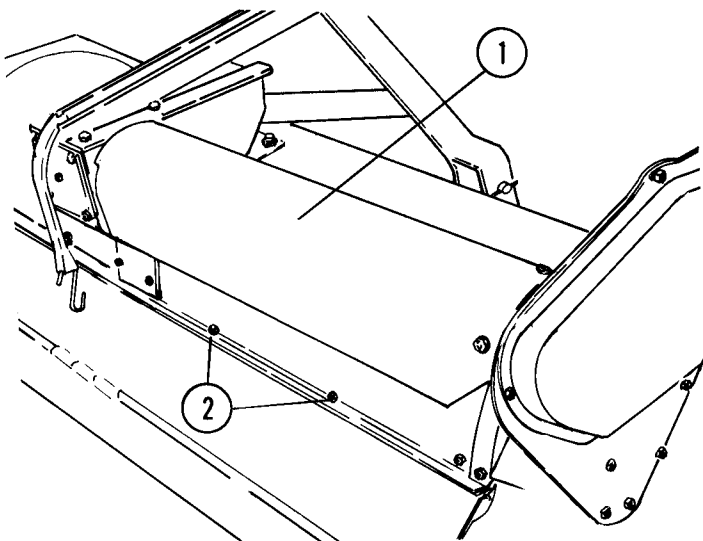

Fig. 16 — Torque Limiter

1. Shield
2. Retaining Bolts

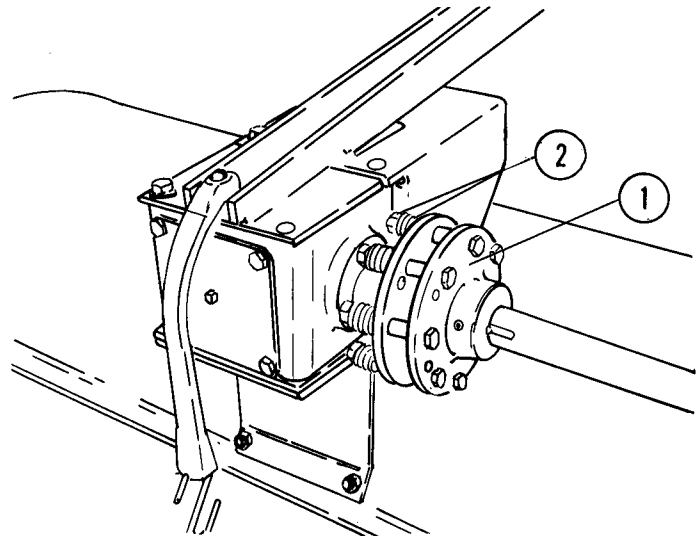

Fig. 17 — Torque Limiter

1. Pressure Plate
2. Adjuster Nuts and Springs

REPLACING OUTER CHAIN DRIVE

1. Remove chain guard by removing 4 retaining bolts, Figure 13.
2. Loosen nut on idler sprocket shaft to slacken chain, Figure 14.
3. Remove drive chain master link and remove chain, Figure 14.
4. Install new chain or repaired chain and adjust idler.

NOTE: The purpose of the idler sprocket is merely to take up slackness in chain and therefore, it should not be adjusted to make the chain overly tight.

5. To adjust idler sprocket, loosen nut on idler sprocket shaft, set sprocket on chain and retighten nuts making sure idler sprocket is line with drive sprocket.

6. Install chain guard and tighten all 4 retaining bolts.

ADJUSTING ENCLOSED DRIVE CHAIN

To adjust tension on enclosed drive chain proceed as follows:

1. Raise Tiller. Tines must clear ground. Shut-off engine and disengage PTO clutch.
2. Loosen jam nut and turn the adjusting screw "in" until a slight drag is felt on chain, Figure 15.

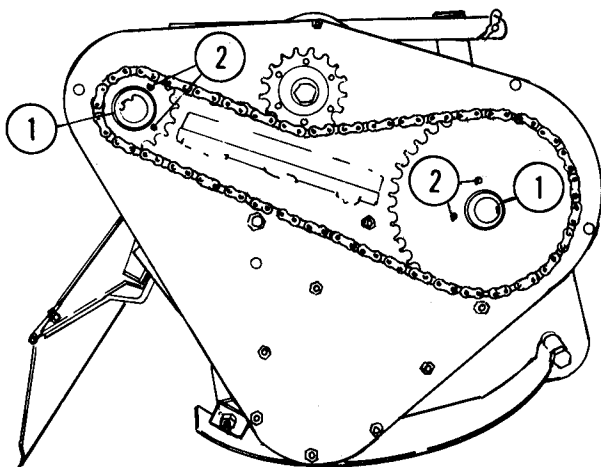

Fig. 18 — Outer Drive Sprockets

1. Snap Rings
2. Set Screws

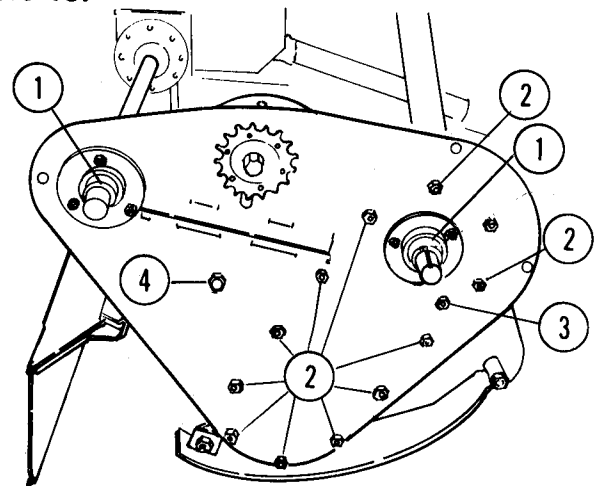

Fig. 19 — Cover Plate Assembly

1. Bearing Locking Collars
2. Cover Retaining Nuts
3. Paddle Retaining Nut
4. Spacer Tube Retaining Nut

3. Move tines back and forth by hand until chain slack or "backlash" is felt. Continue to turn adjusting screw "in" while moving tines until backlash is removed and a slight drag is felt on chain.

4. Turn adjusting screw out approximately 1/2 turn or as necessary until tines turn freely. Tighten jam nut.

ADJUSTING TORQUE LIMITER

If torque limiter slips excessively, check and adjust spring tension. Proceed as follows:

1. Remove shield from top of shroud by removing six bolts, Figure 16.

2. Tighten nuts until the springs are tight against pressure plate then back off 1/2 turn, Figure 17.

IMPORTANT: Do not overtighten nuts as torque limiter cannot function if not properly adjusted.

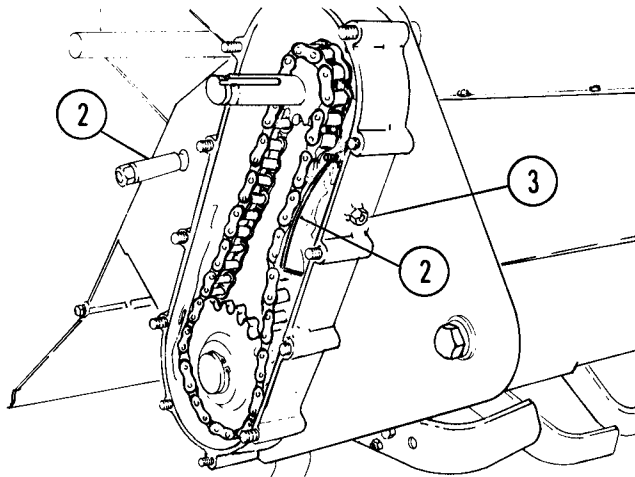

Fig. 20 — Cover Plate Removed

- 1. Paddle Assembly
- 2. Spacer Tube Assembly
- 3. Paddle Assembly Adjuster

3. Replace shield and test adjustment by placing Tiller under normal working load.

4. If torque limiter continues to slip excessively, have your dealer check and repair.

TINE SHAFT & BEARINGS

In the event that the tine shaft and/or bearings need replacement proceed as follows:

1. Remove outer drive chain guard and outer drive chain as shown in Figures 13 and 14.

2. Remove snap rings from each sprocket shaft, Figure 18.

IMPORTANT: During sprocket removal make note of all spacer washer locations to insure proper reassembly. These washers control proper chain alignment.

3. Remove set screws from each sprocket hub, Figure 18.

4. Slide sprockets off shafts.

NOTE: In some cases it may be necessary to use a bearing puller to remove sprockets from shafts.

5. Loosen set screws on bearing locking collars, Figure 19.

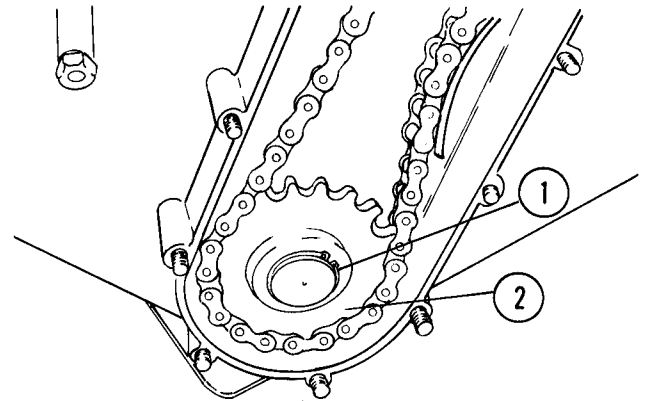

Fig. 21 — Tine Shaft Sprocket

- 1. Snap Ring
- 2. Sprocket

6. With hammer and punch, tap bearing locking collars counter-clockwise until they come loose of bearing, Figure 19.

NOTE: If bearing locking collar does not come loose it may be necessary to tap clockwise.

7. Remove the twelve 3/8" locknuts holding the outer cover assembly, Figure 19.

8. Remove the 5/16" locknut retaining the internal paddle assembly and the 1/2" nut holding the spacer tube assembly, Figures 19 and 20.

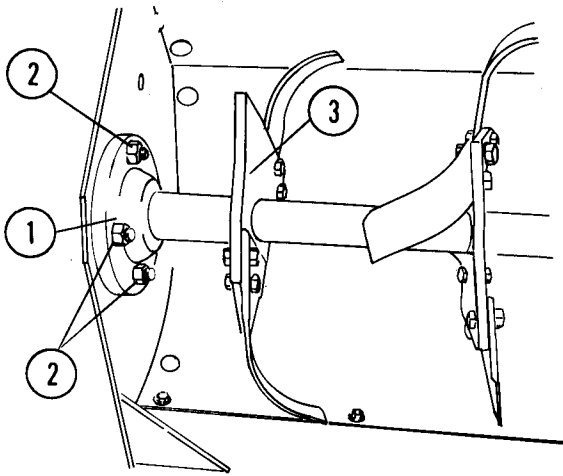

Fig. 22 — Tine Shaft (L.H. Side)

- 1. Dust Cap
- 2. Retaining Nuts
- 3. Outboard Tines Removed

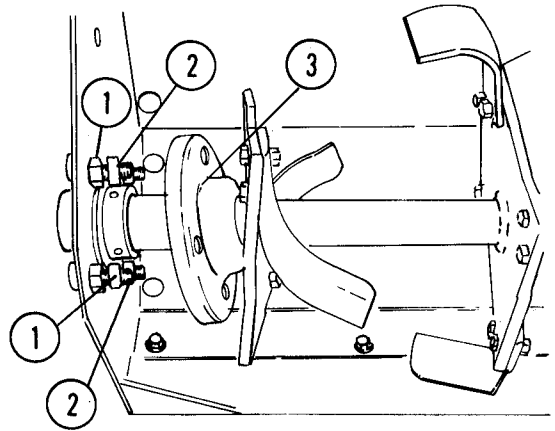

Fig. 23 — Tine Shaft (L.H. Side)

- 1. Bearing Retainer Nuts
- 2. Spacers
- 3. Dust Cap

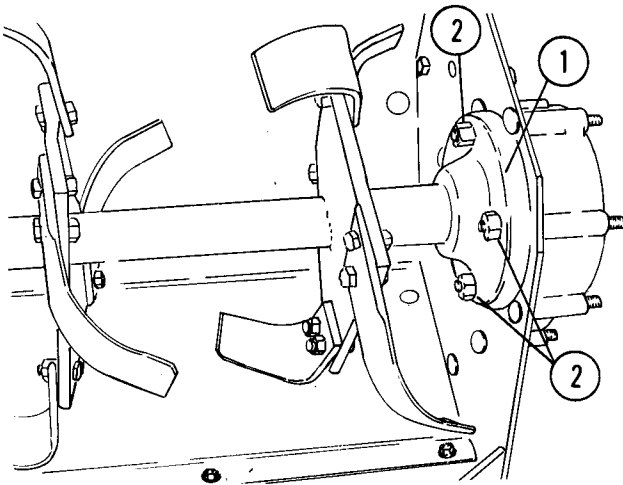

Fig. 24 — Tine Shaft (R.H. Side)

- 1. Dust Cap Retaining Nuts
- 2. Dust Cap

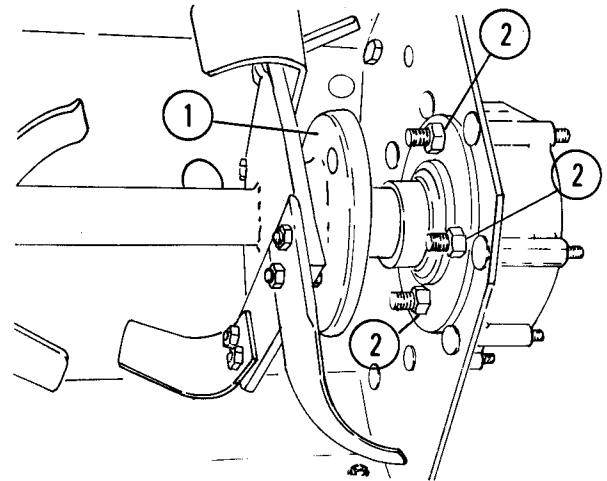

Fig. 25 — Tine Shaft (R.H. Side)

- 1. Dust Cap
- 2. Bearing Retainer Nuts

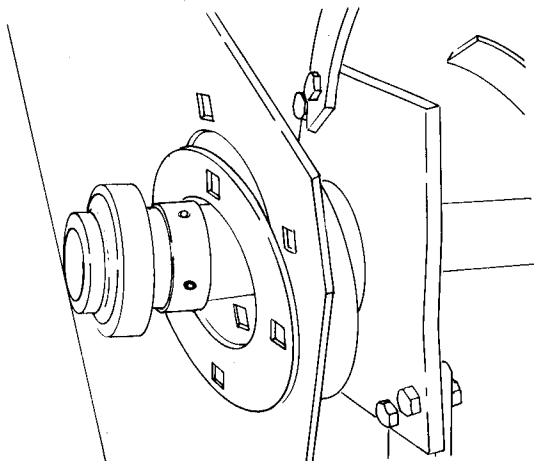

Fig. 26 — Tine Shaft (L.H. Side)

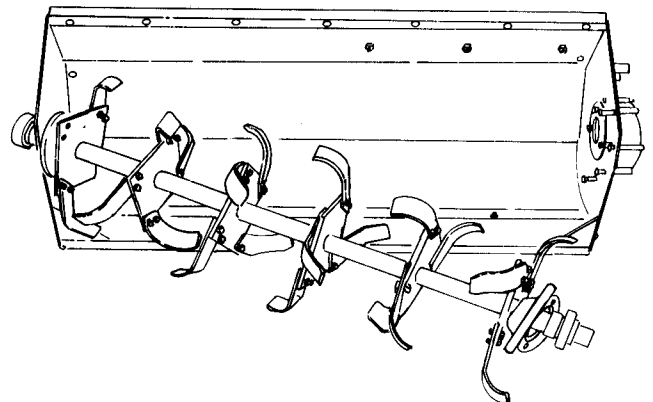

Fig. 27 — Right-Hand Tine Shaft End Removed From Drive Sprocket

NOTE: Before attempting to remove the cover assembly examine each sprocket shaft end and remove any burrs or paint.

9. Remove cover plate carefully as sprocket bearings come off with cover plate.

NOTE: It may be necessary to tap cover plate slightly to break seal.

10. Loosen adjuster, 3, Figure 20, to reduce tension on internal drive chain.

11. Remove snap ring on end of tine shaft, Figure 21.

12. Position Tiller on floor and rotate forward until front hitch "A" frame rests on the

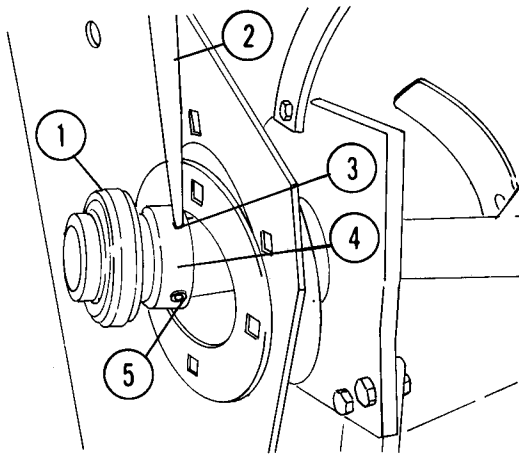

Fig. 28 — Left-Hand Tine Shaft End

1. Bearing
2. Punch
3. Punch Hole In Collar
4. Collar
5. Set Screw

floor and remove 2 outboard tine halves on left-hand side, Figure 22.

13. Remove 4 lock nuts holding the left-hand dust cap and slide dust cap back out of the way. Note that there are 4 spacers under the dust cap and that they must be placed in the same position during reassembly, Figures 22 and 23.

14. Remove 4 spacers and 4 remaining nuts and bolts holding flangettes in place, Figure 23.

RIGHT HAND SIDE

For disassembly of the right hand side proceed as follows:

1. Remove 4 nuts holding dust cap, Figure 24.

2. Remove 4 remaining nuts holding the flangettes in place, Figure 25.

NOTE: No tines need be removed from the right-hand side and there are no spacers under the dust cap.

3. Slide tine shaft assembly to the left until right end comes out of sprocket hub in chain case. Both ends of the tine shaft become accessible as shown in Figures 26 and 27.

NOTE: If difficulty is encountered tap one of the tine plates. NEVER HIT TINE SHAFT.

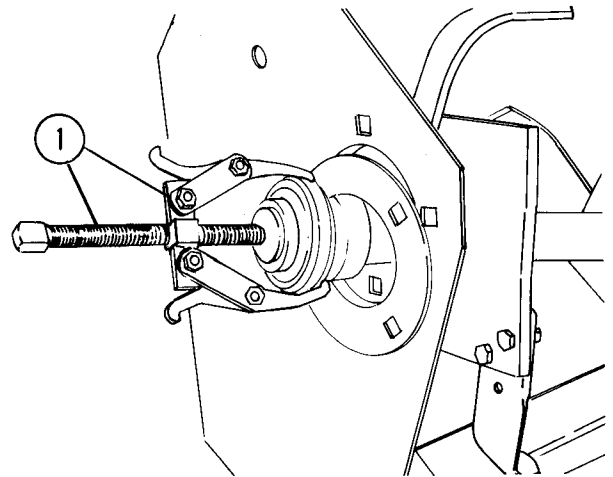

Fig. 29 — Bearing Removal (L.H. Tine Shaft End)

1. Bearing Puller

4. Loosen set screw holding the locking collar on the left side of shaft, Figure 28. Using a hammer andn punch tap the locking collar opposite the rotation of tine shaft until it comes loose from bearing, Figure 28.

5. Using a wheel or bearing puller remove from left end of shaft.

NOTE: It may be necessary to apply penetrating oil to bearing and shaft.

Tine shaft assembly may now be removed from frame.

6. Right-hand bearing may be removed in the same manner.

7. Replace bearings and/or shaft and reassemble.

WARRANTY

MANUFACTURER'S 90 DAY LIMITED WARRANTY

For Ninety (90) days from purchase date for a non-commercial user, or for Thirty (30) days from purchase date for a commercial user, McDONOUGH POWER EQUIPMENT, through any factory authorized service dealer, will replace for the original purchaser, free of charge, any part or parts found upon examination by the factory at McDonough, Georgia, to be defective in material or workmanship or both.

All transportation cost incurred by the purchaser in submitting material to an authorized service dealer for replacement under this warranty must be borne by the purchaser.

This warranty does not apply to parts that have been damaged by accident, alteration, abuse, improper lubrication, normal wear, or other cause beyond our control.

There is no other express warranty.

Implied warranties, including those of merchantability and fitness for a particular purpose, are limited to ninety (90) days from purchase for non-commercial users, and for thirty (30) days from purchase for commercial users and to the extent permitted by law any and all implied warranties are excluded. This is the exclusive remedy. Liabilities for consequential damages under any and all warranties are excluded.

Some states do not allow limitations on how long an implied warranty lasts or do not allow the exclusion or limitation of incidental or consequential damages, so the above limitation or exclusion may not apply to you.

This warranty gives you specific legal rights, and you may also have other rights which vary from state to state.

McDONOUGH POWER EQUIPMENT, McDONOUGH, GEORGIA 30253

Serial identification plate is located on right side of shroud. Record this number in space provided and refer to it when requesting parts.



McDonough Power Equipment, McDonough,
Georgia 30253. A Fuqua Industry.



Free Manuals Download Website

<http://myh66.com>

<http://usermanuals.us>

<http://www.somanuals.com>

<http://www.4manuals.cc>

<http://www.manual-lib.com>

<http://www.404manual.com>

<http://www.luxmanual.com>

<http://aubethermostatmanual.com>

Golf course search by state

<http://golfingnear.com>

Email search by domain

<http://emailbydomain.com>

Auto manuals search

<http://auto.somanuals.com>

TV manuals search

<http://tv.somanuals.com>