



OWNER'S MANUAL

MA-9000AH

Portable Air Conditioner

- *Cooling*
- *Heating*
- *Dehumidifying*
- *Fan*

Please read Owner's Manual
carefully before operating the
unit.



TABLE OF CONTENTS

INTRODUCTION.....	3
IMPORTANT SAFEGUARDS.....	3
PACKAGE CONTENTS.....	4
IDENTIFYING THE PARTS	4
ASSEMBLY REQUIREMENTS	6
CONTROL PANEL AND LCD DISPLAY	7
CONTROL PANEL FUNCTIONS	8
OPERATION USING CONTROL PANEL	9
OPERATION USING REMOTE CONTROLLER	11
CONDENSATE WATER DRAINAGE.....	14
MAINTENANCE.....	16
TROUBLESHOOTING.....	17
TECHNICALSPECIFICATIONS	18
DISCLAIMER	18
CONTACT INFORMATION	18
WARRANTY	19

INTRODUCTION

Thank you for purchasing the Soleus Air MA-9000AH portable air conditioner. This unit is designed to improve living and working comfort by providing cooling, dehumidifying and fan functions with only minimum installation required. With its whisper quiet operation and attractive design, you will enjoy the convenience and comfort that this unit provides for many years to come.

When operating as an air conditioner, this unit is designed for spot cooling or cooling for a room no larger than 300 square feet with a standard ceiling height of 8 feet.

IMPORTANT SAFEGUARDS

Before installing and using the portable air conditioner, please read this Owner's manual carefully.

1. Never use or store gasoline or other flammable vapor or liquid near this unit.
2. Maintain at least 10" (25cm) clearance space around all side of the unit. Do not obstruct air inlet or outlet grilles.
3. All in-home wiring must comply with local and national codes and be installed by a qualified technician. The power supply must be properly grounded. All wiring problems should be resolved by a qualified technician BEFORE installation and use of this air conditioner
4. Always inspect the power cord and plug for signs of damage before use.
5. For your safety, this unit is grounded through the power cord plug when connected to a matching wall outlet. Do not use an adapter plug or extension cord.
6. When removing the power cord from the wall outlet, always grasp the plug firmly and pull straight from the outlet. Never unplug the air conditioner by pulling on the cord itself.
7. Do not use the unit in the immediate surroundings of a bath, a shower or a swimming pool. Never immerse the unit in water or any other liquid.
8. Keep out of reach of children.
9. Use product only as directed in this manual; unintended use may void the warranty.

PACKAGE CONTAINS:

- 1 Portable Air Conditioner
- 1 Air Exhaust Duct
- 1 Window Kit (2 Sliding Panels)
- 1 Window Kit Adapter
- 1 Remote Controller
- 2 AAA Batteries
- 1 User Manual

IDENTIFYING THE PARTS

Front View

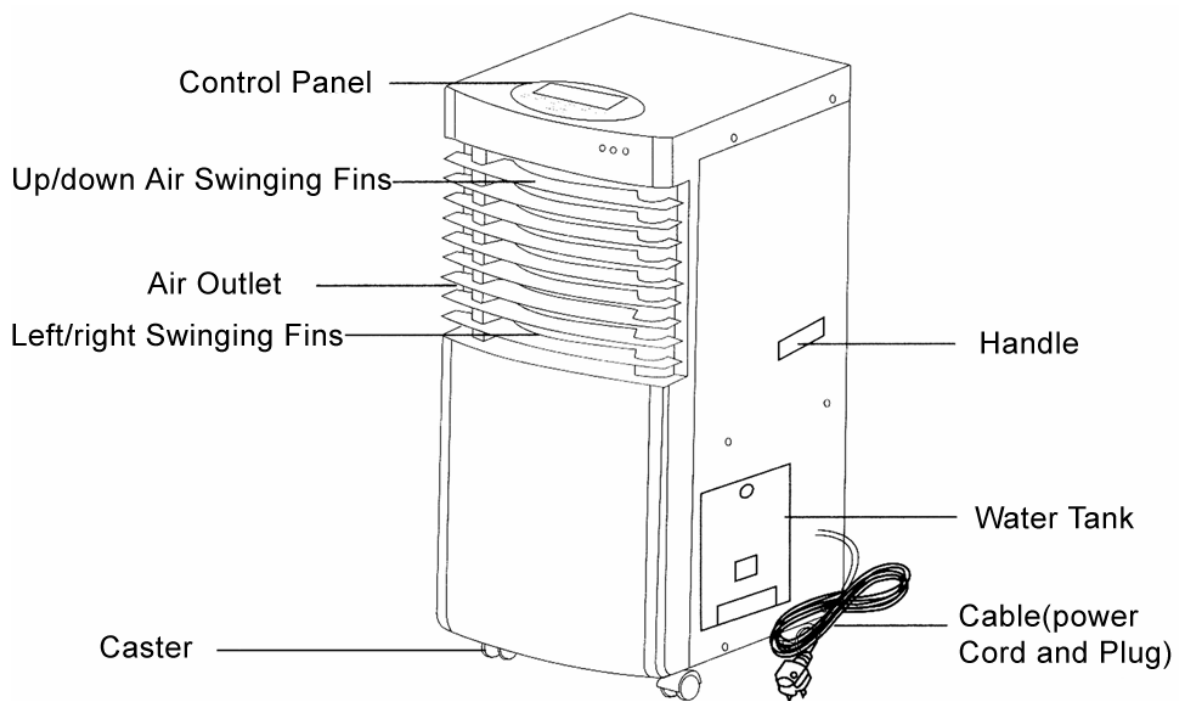

Rear View

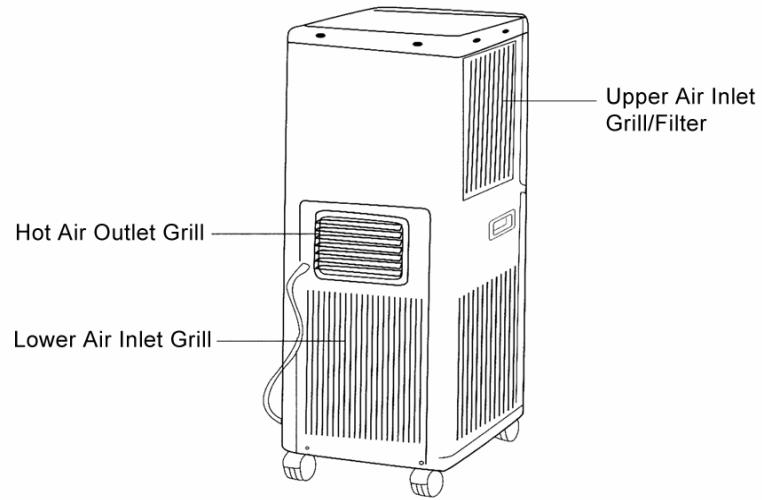

Exhaust Duct

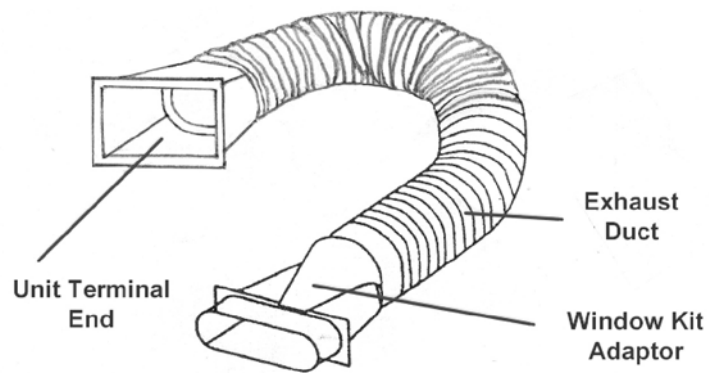

Window Kit

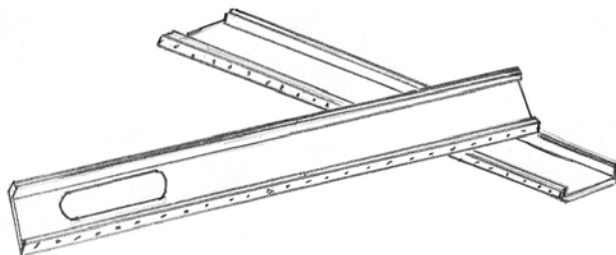

ASSEMBLY REQUIREMENTS

1) Exhaust Duct

When you use the unit as an air conditioner, the hot exhaust air must be directed out of the room. The exhaust duct is required to allow the hot air out of the room through a window. **DO NOT INSTALL OR USE THE EXHAUST DUCT WHEN THE UNIT IS OPERATED AS A DEHUMIDIFIER OR FAN.**

Slide “Unit Terminal End” of the exhaust connector completely over the “Hot Air Outlet Grill” on the rear of the unit. Plastic grooves are located on the hot air outlet help to guide the exhaust connector into place.

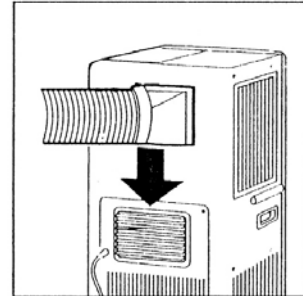

Window Kit Mounting: Connect the window kit adapter to the external end of the exhaust duct. The exhaust duct is now ready to be attached to the window kit. See page 7 for window kit installation

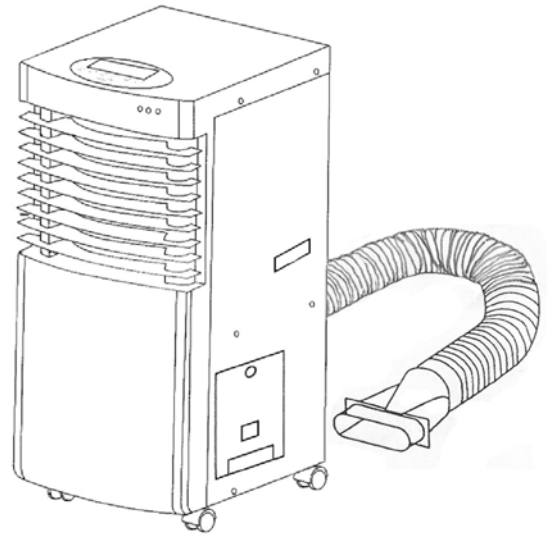

Wall Mounting: Mount the external end of the exhaust duct to a 5¼” hole within the wall. Creating a hole into a wall is a separate procedure that may require professional installation.

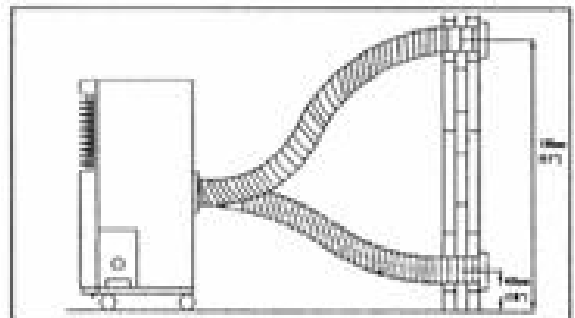

NOTE: In order to achieve maximum room cooling efficiency, the exhaust duct should remain as short and straight as possible. To further shorten the exhaust hose, first unthread either exhaust duct adapter clockwise to remove it. Then cut the hose to desired length. It is not recommended to increase the manufacturer's length of the exhaust hose. This may reduce the cooling efficiency or damage the unit.

2) Window Kit Installation

- a. Open window approximately 5 inches (13 cm)
- b. Adjust the length of the window kit to the same length of the window; use both panels if necessary. The window kit has a maximum length 50.5 inches.
- c. Place the window kit between the window and the window frame as shown in the picture to the right. Close the window onto the window kit to form a tight seal.
- d. Attach the exhaust duct window kit adapter to the window kit. Tabs located on the adapter will lock into place securing the adapter to the window kit.

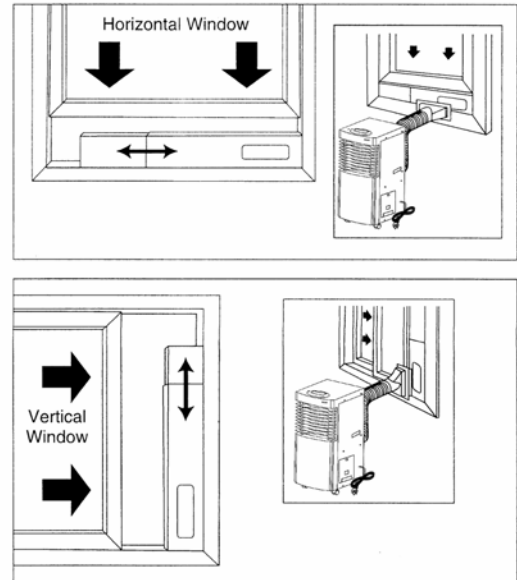

NOTE: Using the window kit will cause the window not to be properly closed and locked. Additional security measurements should be taken.

CONTROL PANEL AND LCD DISPLAY

CONTROL PANEL

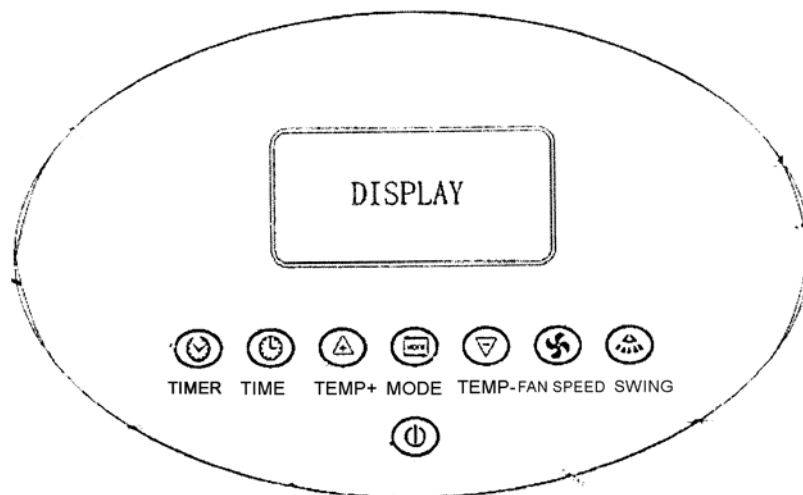

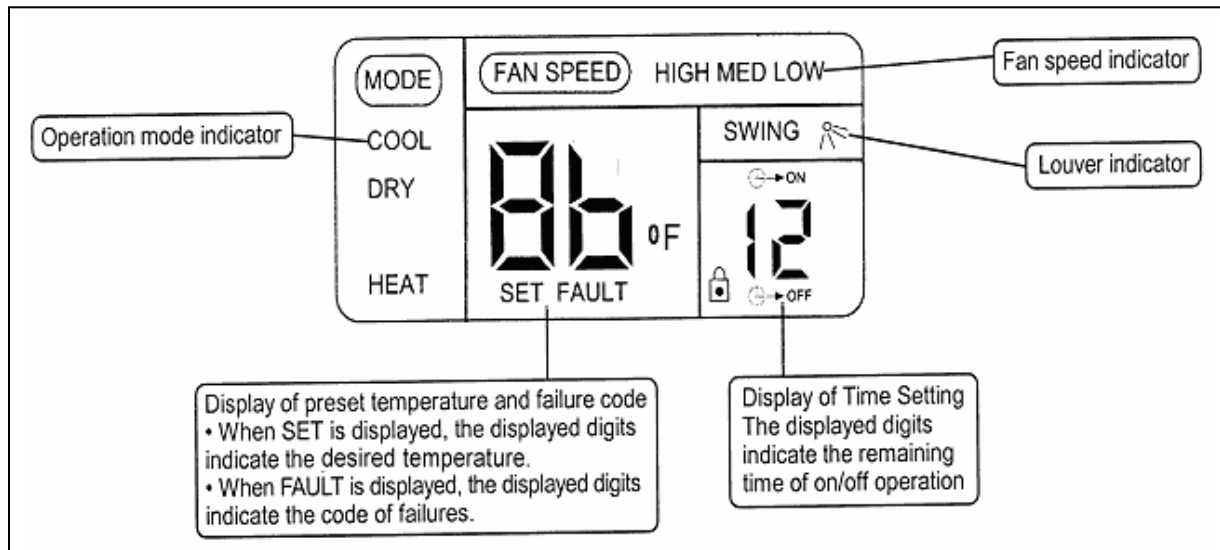

Control Panel Functions



1. **Power On/Off Control**
Starts or stops the unit
2. **Temperature Setting Control**
Select the desired temperature setting by pressing either the Δ or ∇ key. It is recommended to set the temperature before selecting the Mode Control.
3. **Mode Control**
Select the functions of the unit for:
 - a. Air Conditioning Mode (COOL)
 - b. Dehumidifying Mode (DRY)
 - c. Heating Mode (HEAT)
4. **Fan Speed Control**
Select the fan speed for:
 - a. High
 - b. Medium
 - c. Low
5. **Timer + Time**
Sets the amount of time, in hours, to automatically start or to stop the unit

- a. When the unit is On, press “Timer” Button, then press the “Time” button until the desired number of hours is displayed in the lower right corner of the display window. The unit will automatically power Off once the selected number of hours has elapsed.
- b. When the unit is Off, press “Timer” Button, then press the “Time” button until the desired number of hours is displayed in the lower right corner of the display window. The unit will automatically power On once the selected number of hours has elapsed.

NOTE: The timer function must be manually reset before each automatic start or stop.

6. Swing
Activates or deactivates the oscillating louvers

Operation Using the Control Panel

1. Cooling Operation
 - a. Be sure that the drain bucket is properly placed in the unit. If the drain bucket is not properly secured, the red “Water Full” light located on the front panel will blink and the unit will not begin cooling.
 - b. Be sure the exhaust duct properly installed. Refer to page 6 for exhaust duct installation.
 - c. Plug the Power Cord to the power outlet.
 - d. Turn on the unit by pressing the On/Off Button on the control panel.
 - e. Press the Mode Button until “COOL” appears on the LCD display.
 - f. Press the Temperature Button  or  until the desired room temperature appears on the LCD. The temperature ranges from 63°F-88°F (17°C-31°C). After two seconds the current room temperature will appear on the LCD screen



NOTE: During hot days, the unit will cool off the room most efficiently by setting the temperature to the lowest setting and the fan speed to the highest setting (see page 9 for fan operation). Reducing the length of the exhaust duct, insulating the exhaust duct and keeping direct sunlight to a minimum will also improve the cooling efficiency.

2. Dehumidifying Operation



- a. Be sure that the drain bucket is properly placed in the unit. If the drain bucket is not properly secured in the unit, the red “Water Full” light located on the front panel will blink and the unit will not begin dehumidifying.
- b. If exhaust duct is attached, remove it from the rear of the air conditioner
- c. Plug the Power Cord to the power outlet.
- d. Turn on the unit by pressing the On/Off Button on the control panel.
- e. Press the Mode Button until “DRY” appears on the LCD display.

NOTE: Do not use the exhaust duct when the unit is running at dehumidifying mode. You must remove the exhaust duct from the unit. When the unit is running at dehumidifying mode, the fan speed cannot be adjusted. Keep the windows and the doors closed to aid the efficiency of the unit in removing the moisture from the room.

3. Fan Operation

- a. Plug the Power Cord to the power outlet.
- b. Turn on the unit by pressing the On/Off Button on the control panel.
- c. Press the Mode Button until “COOL” appears on the LCD display.
- d. Press the Temperature Button  or  to set the temperature HIGHER than the current room temperature. After two seconds the current room temperature will appear on the LCD screen.
- e. Set the fan speed to “LOW” “MEDIUM” or “HIGH” by pressing the Fan Speed button.

4. Heating Operation

- a. Plug the Power Cord to the power outlet.
- b. Turn on the unit by pressing the On/Off Button on the control panel.
- c. Press the Mode Button until “Heat” appears on the LCD display.
- d. Press the Temperature Button  or  until the desired room temperature appears on the LCD. The temperature ranges from 63°F-88°F (17°C-31°C).

NOTE: When the unit is operating in heating mode, the exhaust duct is not required.

OPERATION USING REMOTE CONTROLLER

REMOTE CONTROLLER

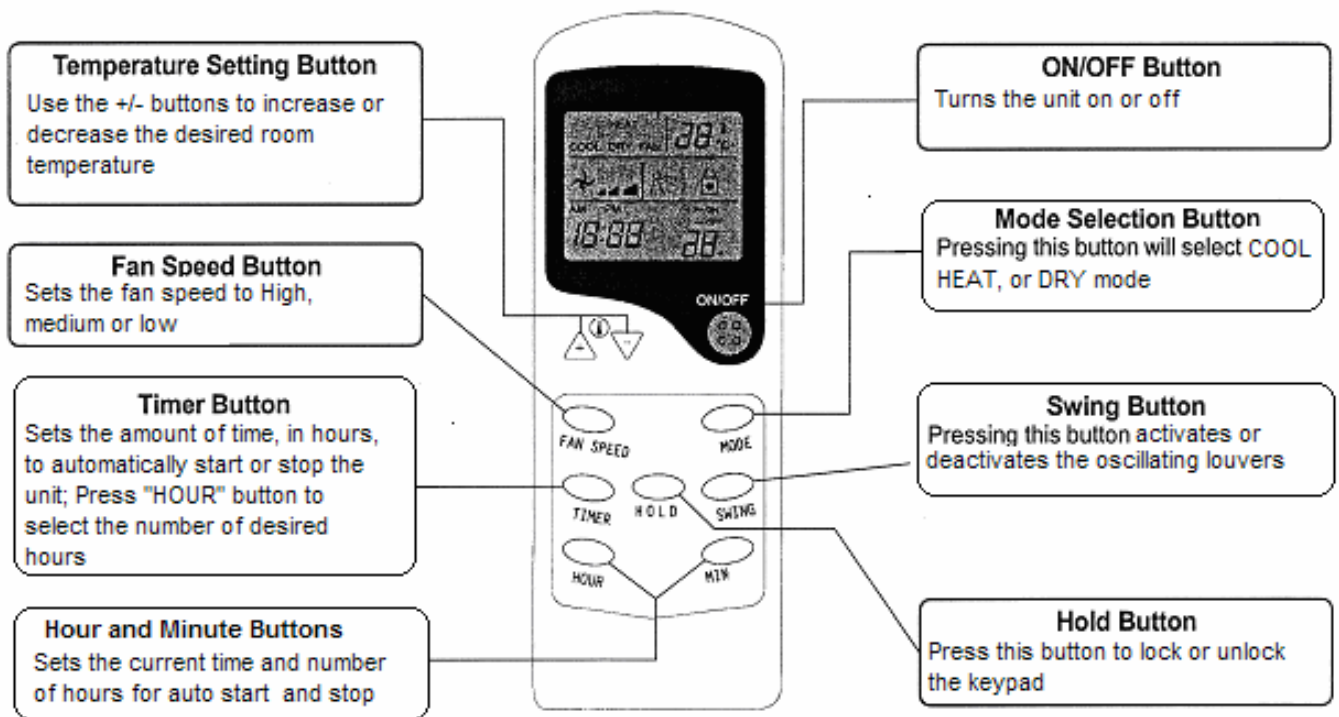

1. To Set the Clock

Open the back cover of the remote controller and insert two AAA batteries. When batteries

are installed or replaced, the clock is set to 12:00AM. To set present time:





Slide the back cover:

1	Press the CLK button. Remove the back cover, push the clock button with the tip of a ball pen, etc. When the time indicator flashes the current time may be set.
2	Press the HOUR button to Select the hour
3	Press the MIN button to Select the minute
4	Press the CLK button again, then reattach the back cover.

2. Cooling Operation

- a. Be sure that the drain bucket is properly placed in the unit. If the drain bucket is not properly secured, the red “Water Full” light located on the front panel will blink and the unit will not begin cooling.
- b. Be sure the exhaust duct properly installed. Refer to page 6 for exhaust duct installation.
- c. Plug the Power Cord to the power outlet.
- d. Press the ON/OFF key to turn on the unit
- e. Press the Mode key until the LCD displays “COOL”
- f. Press either Δ or ∇ key of the Temperature key until the LCD displays the desired temperature
- g. Press the Fan Speed key until the LCD displays the desired fan speed.

3. Heating Operation



- a. Plug the Power Cord to the power outlet.
- b. Turn on the unit by pressing the On/Off Button on the remote control.
- c. Press the Mode Button until “Heat” appears on the LCD display.
- d. Press the Temperature Button  or  until the desired room temperature appears on the LCD. The temperature ranges from 63°F-88°F (17°C-31°C).

NOTE: When the unit is operating in “HEAT” mode, the exhaust duct is not required.

4. Dehumidifying Operation

- a. Be sure that the drain bucket is properly placed in the unit. If the drain bucket is not properly secured, the red “Water Full” light located on the front panel will blink and the unit will not begin dehumidifying.
- b. If attached, remove the exhaust duct from the back of the air conditioner
- c. Plug the Power Cord to the power outlet.
- d. Press the ON/OFF key to turn on the unit
- e. Press Mode key until “DRY” appears on the LCD display.

5. Fan Operation

- a. Press the ON/OFF key to turn on the unit
- b. Press the Mode key until “COOL” appears on the LCD display.
- c. Press either  or  key of the temperature to set the temperature HIGHER than the current room temperature.
- d. Press the Fan Speed key until the LCD displays the desired fan speed.

7. Timer

- a. When the unit is On, press “Timer” Button, then press the “Hour” button until the

desired number of hours is displayed in the LCD. The unit will automatically power Off once the selected number of hours has elapsed.

- b. When the unit is Off, press “Timer” Button, then press the “Hour” button until the desired number of hours is displayed in the LCD. The unit will automatically power On once the selected number of hours has elapsed.

NOTE: The timer function must be manually reset before each automatic start or stop.

CONDENSATE WATER DRAINAGE

1) Internal Water Bucket

When operating in cooling or dehumidifying mode, the condensate water will drain into the internal water bucket. *Depending on the surrounding humidity*, the unit can continuously operate for 2 to 12 hours before the internal water bucket is full. When the internal water bucket becomes full, the red “Water Full” light located on the front of the unit will flash. The compressor will stop, but the fan will continue to run at the set speed.

To empty the water bucket:

- a. Turn the unit off.
- b. Remove water bucket slowly and discard the water inside the bucket.
- c. Place the bucket back to its original position
- d. Turn the unit on

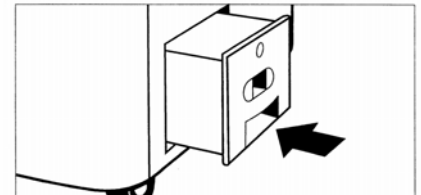

*The drain bucket may be emptied before it is full. First turn off the unit, then wait 3 minutes before removing the water bucket to prevent the condensate water from discharging into the unit.

NOTE: If you remove the water bucket while the unit is operating in cooling or dehumidifying mode the red “Water Full” Light will flash and the compressor will stop. Once the drain bucket is placed back in the unit, the compressor will remain off for approximately 3 minutes before restarting the cooling or dehumidifying cycle.

2) Continuous Drainage

The unit can operate on continuous drainage mode. When the unit is operating on continuous drainage mode, condensate water will not drain into the internal water bucket. Condensate water

is discharged by gravity through a drainage tube (12" length) to either an external hose (not included) or to a condensate water pump device (not included). When the unit is operating on continuous drainage mode, it can operate continuously without periodic stops to empty the water bucket.

To allow continuous drainage:

- a. Remove the water bucket from the cabinet.
- b. Find the tube hanging beside the water bucket inside of the cabinet.
- c. Remove the plug from the end of the tube.
- d. Connect the drainage tubing to a hose. Use a clamp or adapter (not provided) if necessary
- e. Place the other end of the hose into either an external water bucket, a floor drain or the intake side of a condensate water pump.

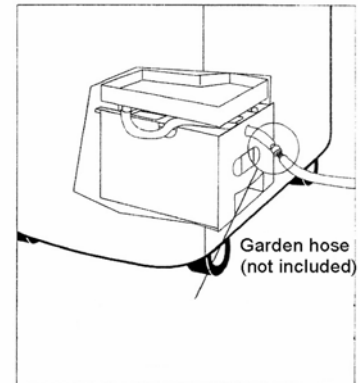

NOTE: When using the continuous drainage method, the unit will NOT shut off automatically when an external water bucket is full. Spill water can cause substantial damages to carpet, floors, furniture and other valuables.

NOTE: Do not use a lengthy drainage hose without a condensate water pump as water may overflow into the internal drain bucket which requires periodic manual drainage

MAINTENANCE

Note: Before performing any maintenance activities turn the unit off and remove the power plug from the power outlet.

1) Clean or Replace Filter

- a. If the air filter is clogged, the airflow volume will decrease, reducing cooling efficiency. It is recommended to clean the filter once a month or as needed.
- b. Push down the tab on the filter cover and pull outwards to remove the entire filter and cover.
- c. Carefully remove the air filter from the filter cover.
- d. Wash the air filter by immersing it gently into warm water with a mild detergent.
- e. Rinse the filter thoroughly and dry it in a shaded place.
- f. Attach the filter to the filter cover with the attachment hooks located on the inside surface of the cover
- g. Place the bottom of the filter cover into the holes in the unit case. Push the cover back into its original position.

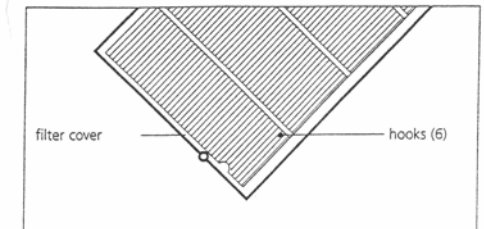
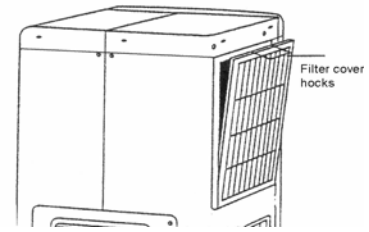

2) Case

- a. Avoid direct exposure to sunlight as case color may fade.
- b. Clean surface area with a damp cloth. Dry with a soft towel.
- c. Do not use abrasive cleaning products.

3) Storing the Unit for an Extended Period of Time or Transporting

- a. Unplug the unit from the power outlet.
- b. Ensure that the water bucket is empty.
- c. If using continuous drainage, disconnect any external drain hose and cap the end of the internal drain tube.
- d. Store and transport unit in an upright position. Store unit in a cool dry place.

TROUBLESHOOTING

PROBLEM	POSSIBLE CAUSE	REMEDY
Unit does not operate	Unit is unplugged	Securely plug receptacle into the power outlet
	Drain bucket is full	Empty water bucket
	Water bucket not installed correctly	Completely insert water bucket
	Air exhaust is clogged	Remove obstruction from exhaust hose
	Timer is on	Cancel the timer
Unit does not cool room	There is a heating source in the room	Turn down or off the other heating source
	Temperature setting is too high	Lower temperature setting
	Air filter is dirty	Clean or replace the air filter
	Air exhaust is not installed correctly	Check the exhaust duct to make sure that the hot exhaust air is being vented out of the room
	Room is too big or too much ambient sunlight is reaching in	This unit provides spot cooling or cooling for a room no larger than 300 square feet with standard ceiling height
	There is frost on the evaporator	The unit will defrost automatically and return to operation afterwards
In dehumidifying mode, no cool air coming out	There is frost on the evaporator	The unit will defrost automatically and will return to operation afterwards
“Water Full” indicator is blinking	The water bucket is full	Empty the water bucket
	The water bucket is not installed correctly	Completely insert the water bucket
Noise or vibration	Surface is not level	Place unit on a level surface and away from obstructions
Water is leaking from unit	Surface is not level	Place unit on a level surface
	Drainage plug is loose	Make drain tube is properly secured and plugged

TECHNICAL SPECIFICATIONS

MODEL		MA-9000AH
COOLING CAPACITY		9000 BTU/hr
HEATING CAPACITY		1100 W
DEHUMIDIFYING CAPACITY		88 Pints/Day
POWER	COOLING/HEATING	1120W/1350W
	DEHUMIDIFYING	1100W
AIR FLOW VOLUME		180 CFM
POWER SOURCE	VOLTAGE	115 V 60 HZ
	RATED CURRENT	11.5 AMP COOLING 11.7 AMP HEATING
SOUND PRESSURE LEVEL		54 db
NET WEIGHT		77 Lbs
DIMENSIONS	BODY	17¼ x 14¾ x 32½ Inches
	PACKAGE	26½ x 18½ x 34½ Inches
REFRIGERANT		R22
WATER BUCKET VOLUME		4L

NOTE:

- 1) The above cooling capacity is measured at ambient temperature of DB 86 F, WB 78 F.
- 2) Noise level is measured at the point where is 3.28 ft away from the front of the unit, in cooling mode.
- 3) Power consumption is measured when fan runs at the highest speed Specifications above are for reference only. Please see the actual data printed on the nameplate.

DISCLAIMER

ALL INFORMATION AND THE TECHNICAL SPECIFICATIONS PRESENTED IN THIS USER'S MANUAL ARE THE PRESENTATION OF THE MANUFACTURER. SOLEUS INTERNATIONAL HAS NOT CONDUCTED INDEPENDENT TEST OF THE INFORMATION AND THE SPECIFICATIONS PRESENTED HEREWITHIN.

CONTACT INFORMATION

Contact Customer Service at our toll free number for:

Optional or Spare Parts
 Technical Support
 Warranty Claims

Soleus International Inc. **1.888.876.5387**

WARRANTY

ONE YEAR LIMITED WARRANTY

Soleus International Inc. warrants the accompanying MA-9000AH Soleus Air air conditioner to be free of defects in material and workmanship for the applications specified in its operation instruction for a period of ONE (1) year from the date of original retail purchase in the United States or Canada.

If the air conditioner exhibits a defect in normal use, Soleus International Inc. will, at its option, either repair or replace it, free of charge within a reasonable time after the air conditioner is returned during the warranty period.

As a condition to any warranty service obligation, the consumer must present this Warranty Certificate along with a copy of the original purchase invoice.

THIS WARRANTY DOES NOT COVER:

- 1) Damage, accidental or other wise, to the air conditioner while in the possession of a consumer not caused by a defect in material or workmanship.
- 2) Damage caused by consumer misuse, tampering, or failure to follow the care and special handling provisions in the instructions.
- 3) Damage to the finish of the case, or other appearance parts caused by wear.
- 4) Filter.
- 5) Damage caused by repairs or alterations of the air conditioner by anyone other than authorized by Soleus International Inc.
- 6) Freight and Insurance cost for the warranty service.

This warranty covers only new products purchased from our authorized dealers or retailers. It does not cover used, salvaged, or refurbished products.

ALL WARRANTIES, INCLUDING ANY IMPLIED WARRANTY OR MERCHANTABILITY ARE LIMITED TO ONE-YEAR DURATION OF THIS EXPRESS LIMITED WARRANTY. SOLEUS INTERNATIONAL INC. DISCLAIMS ANY LIABILITY FOR CONSEQUENTIAL OR INCIDENTAL DAMAGES AND IN NO EVENT SHALL SOLEUS INTERNATIONAL INC.'S LIABILITY EXCEED THE RETAIL VALUE OF THE AIR CONDITIONER FOR BREACH OF ANY WRITTEN OR IMPLIED WARRANTY WITH RESPECT TO THIS AIR CONDITIONER

Serial No 

Free Manuals Download Website

<http://myh66.com>

<http://usermanuals.us>

<http://www.somanuals.com>

<http://www.4manuals.cc>

<http://www.manual-lib.com>

<http://www.404manual.com>

<http://www.luxmanual.com>

<http://aubethermostatmanual.com>

Golf course search by state

<http://golfingnear.com>

Email search by domain

<http://emailbydomain.com>

Auto manuals search

<http://auto.somanuals.com>

TV manuals search

<http://tv.somanuals.com>