



SONAMP[®] 875D SE 8-CHANNEL AMPLIFIER

INSTRUCTION MANUAL

Important Safety Information

IMPORTANT: Read all of these instructions before you install or operate your 875D SE, and save these instructions for later use.

- 1. Read Instructions** — All these safety and operating instructions should be read before you operate the unit.
- 2. Retain Instructions** — These safety and operating instructions should be retained for future reference.
- 3. Heed Warnings** — All warnings on the unit and in the operating instructions should be adhered to.
- 4. Follow Instructions** — All operating and use instructions should be followed.
- 5. Water and Moisture** — The unit should not be used near water — for example, near a bathtub, washbowl, kitchen sink, laundry tub, in a wet basement, or near a swimming pool, and the like.
- 6. Carts and Stands** — The unit should be used only with a cart or stand that is recommended by the manufacturer.
 - A unit and cart combination should be moved with care. Quick stops, excessive force, and uneven surfaces may cause the unit and cart combination to overturn.
- 7. CAUTION:** To prevent electric shock, do not use the amplifier's polarized plug with an extension cord, receptacle, or other outlets unless the blades can be fully inserted to prevent blade exposure.
- 8. Ventilation** — The unit should be situated so that its location or position does not interfere with its proper ventilation. For example, the unit should not be situated on a bed, sofa, rug, or similar surface that may block the ventilation openings; or be placed in a built-in installation, such as a bookcase or cabinet, that may impede the flow of air through the ventilation openings.
- 9. Heat** — The unit should be situated away from heat sources such as radiators, heat registers, stoves, or other appliances (including other audio components) that produce heat.
- 10. Power Sources** — The unit should be connected to a power supply only of the type described in the operating instructions or as marked on the unit.
- 11. Grounding or Polarization** — Precautions should be taken so that the grounding or polarization means of the unit is not defeated.



- 12. Power Cord Protection** — Power supply cords should be routed so that they are not likely to be walked on or pinched by items placed upon or against them, paying particular attention to cords at plugs, convenience receptacles, and the point where they exit from the controller.
- 13. Cleaning** — The unit should be cleaned only as recommended by the manufacturer.
- 14. Non-Use Periods** — The power cord of the unit should be unplugged from the outlet when left unused for a long period of time.
- 15. Object and Liquid Entry** — Care should be taken so that objects do not fall and liquids are not spilled into the enclosure through openings.
- 16. Damage Requiring Service** — The unit should be serviced by qualified service personnel when:
 - a. The power-supply cord or the plug has been damaged; or
 - b. Objects have fallen or liquid has been spilled into the unit; or
 - c. The unit has been exposed to rain; or
 - d. The unit does not appear to operate normally or exhibits a marked change in performance; or
 - e. The unit has been dropped or the enclosure damaged.
- 17. Servicing** — The user should not attempt to service the unit beyond that described in the operating instructions. All other servicing should be referred to qualified service personnel.



CAUTION: TO REDUCE THE RISK OF ELECTRIC SHOCK, DO NOT REMOVE COVER OR BACK. NO USER-SERVICEABLE PARTS INSIDE. REFER SERVICING TO AUTHORIZED SERVICE PERSONNEL.

WARNING: TO PREVENT FIRE OR SHOCK HAZARD, DO NOT EXPOSE THIS APPLIANCE TO RAIN OR MOISTURE. THE APPLIANCE SHALL NOT BE EXPOSED TO DRIPPING OR SPLASHING. NO OBJECTS FILLED WITH LIQUIDS SHALL BE PLACED ON THE APPLIANCE.



The lightning flash with arrowhead symbol, within an equilateral triangle, is intended to alert the user to the presence of uninsulated dangerous voltage within the product's enclosure that may be of sufficient magnitude to constitute a risk of electric shock to persons.



The exclamation point within an equilateral triangle is intended to alert the user to the presence of important operating and maintenance (servicing) instructions in the literature accompanying the appliance.

Introduction

Thank you for purchasing the Sonance Sonamp® 875D SE power amplifier. The 875D SE will provide you with many years of home entertainment enjoyment. This manual will teach you all about your new amplifier's many innovative features and will show you how to get the very best performance from your amplifier. Please read it thoroughly.

Design and Features

Power

The Sonamp® 875D SE is a hybrid amplifier that combines digital amplification with analog power supplies. Its Class T amplifier with Digital Power Processing™ technology delivers the high efficiency of digital (Class D) amplification with the superior sound quality of analog (Class AB) amplifiers. This allows the 875D SE to deliver high power (75 watts RMS per channel @ 8 ohms x 8 Channels) in an exceptionally small (2U rack height) package. And unlike conventional digital amplifiers which cannot operate in bridged configuration, the 875D SE's Class T circuitry allows you to operate it with any of its four pairs of channels in a bridged mode, providing 300 watts x 4 channels into an 8-ohm load. Four independent power supplies (one for each zone) supply plenty of current, so each zone can maintain full performance regardless of how hard any other zones are being driven.

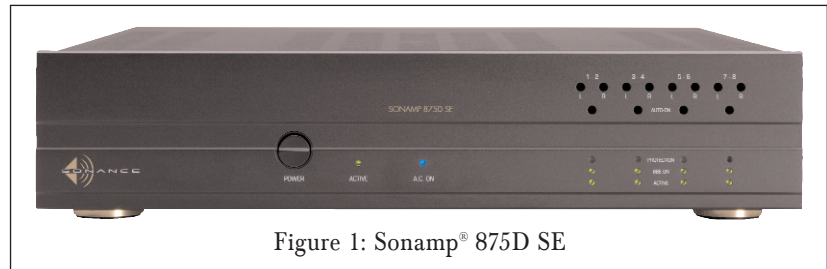

Figure 1: Sonamp® 875D SE

BBE® Sound Enhancement

The Sonamp 875D SE incorporates BBE® Sound Enhancement. The BBE process improves the presence and detail of speakers, especially at lower listening volumes, improving the sound quality of your music — especially distributed audio systems playing background music. BBE also restores clarity and definition (or focus) to spoken voices, which makes paging systems easier to understand without having to run them at high volumes. Each zone in the 875D SE has individual controls that let you set the BBE enhancement for that zone to +9dB, +6dB or OFF. The factory default setting is +6dB.

Inputs and Triggers

Multiple audio input connections (DIRECT, L/R & AUX) and buffered line outputs make your 875D SE extremely flexible, so you can connect the amplifier in a variety of ways depending on your particular system's configuration. The illustrations on pages 15 – 20 show the 875D SE being used in several different possible system configurations. Each zone has its own 12V input and output triggers and defeatable auto-on signal sensing that can automatically turn the amplifier ON. Recessed front-panel controls are tamper-resistant, and let you adjust each channel's input level and each zone's auto-on sensitivity. Front-panel LEDs tell you if the 875D SE's power is on or off, if each Zone is on or off, and the BBE status and fault status for each zone.

Serial Control Capability

The 875D SE's RS-232 connection lets you use a variety of 3rd-party serial control systems to control the amplifier. The serial control provision lets you control almost all of the 875D SE's functions, and also lets you monitor the amplifier's operation from a remote location.

SONAMP® 875D SE 8-CHANNEL AMPLIFIER

FRONT PANEL

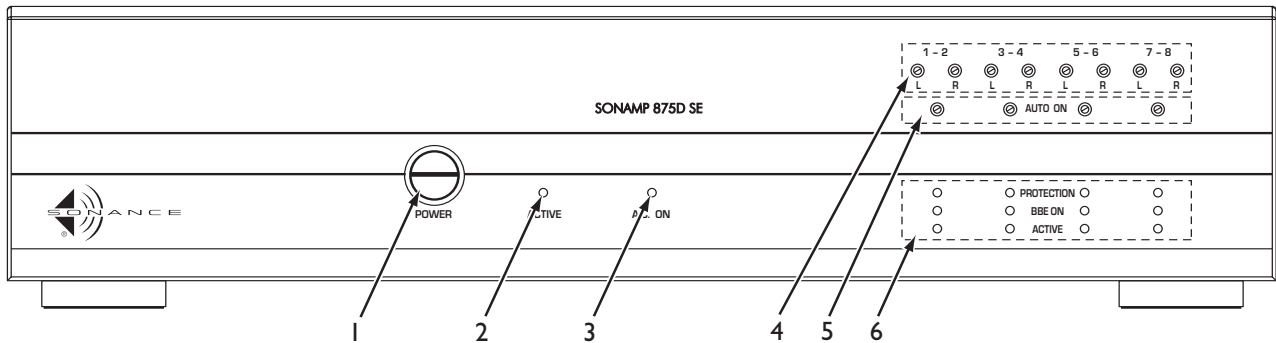

1. Power Button
2. Active LED
3. AC On LED
4. Input Level Adjustments (Ch 1 – 8)
5. Auto-On Sensitivity Adjustments (Zones 1 – 4)
6. Protection, BBE On & Status Indicators (Zones 1 – 4)

REAR PANEL

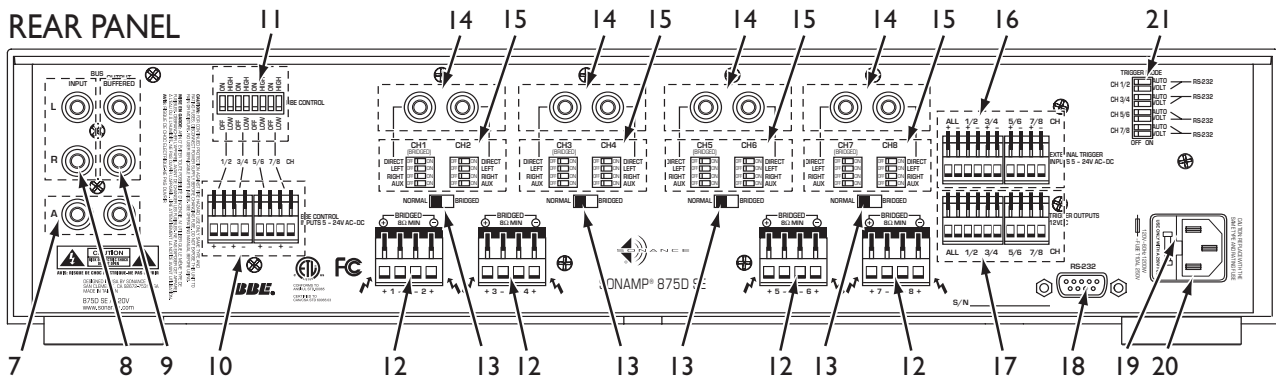

7. Aux Input & Buffered Output
8. Left & Right Bus Inputs
9. Left & Right Buffered Outputs
10. BBE External Control Input Connections (Zones 1 – 4)
11. BBE Control Setting DIP Switches (Zones 1 – 4)
12. Speaker Connectors (Zones 1 – 4)
13. Bridging Switches (Zones 1 – 4)
14. Direct Input Connections (Ch. 1 – 8)
15. Input Assignment DIP Switches (Ch. 1 – 8)
16. External Control Input Connections (Zones 1 – 4 & ALL)
17. 12V Trigger Outputs (Zones 1 – 4 & ALL)
18. RS-232 Control Input
19. AC Fuse Holder
20. Power Cord Connection
21. Trigger Mode Switches (Zones 1 – 4)

Figure 2: 875D SE Front and Rear Panels

Box Contents

Your Sonamp 875D SE box should contain the following items:

- (1) Sonamp 875D SE amplifier
- (2) Rack ears
- (6) Removable control connectors — connected to the amplifier's rear panel
- (4) Removable speaker connectors — connected to the amplifier's rear panel
- (1) IEC Power cable

Unpacking

Save the shipping carton and polystyrene inserts so you can safely transport your amplifier in the future. Before you install the amplifier, locate the serial number on the rear panel and note it here for future reference:

S/N: _____

Placement

IMPORTANT: To avoid damage, the amplifier must always rest on its four feet to allow sufficient clearance for proper ventilation.

Place the Sonamp 875D SE on a level surface, in an upright position, out of direct sunlight and away from windows through which rain may enter.

Situate the amplifier away from heat sources such as hot air ducts or radiators. Be sure that the amplifier is adequately ventilated by convection cooling or suitable cabinet fans.

IMPORTANT: The 875D SE requires four inches of clearance on the top and all sides.

- Never place any object on or against the amplifier.
- Never operate the amplifier on a carpeted surface as this will compromise ventilation.
- When the amplifier is installed in any cabinet, the front or back must be open during operation. Alternately, install fans in the cabinet to assure continuous ventilation.
- When rack-mounting, use nylon washers on both sides of the ears to isolate the amplifier from the rack and prevent ground loops and hum problems.
- Very sensitive low-level sources might pick up some hum radiated from the 875D SE's power supply. If this occurs, move the unit away from the other components.

Protection Circuits

Thermal Protection

If the amplifier's cooling vents are blocked, or it is installed with inadequate ventilation the amplifier may exceed its safe operating temperature. If the amplifier's internal temperature exceeds 154°F (68°C) it will self-protect, and the following will occur:

- The audio output to all connected zones will shut OFF.
- The front-panel PROTECTION LEDs (see *Figure 3*) will illuminate *yellow*.
- An over-temp message will be sent via RS-232.

Once a safe temperature (<67°C) is reached, the Protection LEDs will all extinguish. You can then re-activate the amplifier, either by switching the front-panel Power button OFF and ON or by a 'Power' command if the amplifier is being serial controlled.

IMPORTANT: Before re-activating the amplifier, correct the problem that caused the over-temperature condition (volume set too high, inadequate ventilation, etc.)

NOTE: If you're serial-controlling the 875D SE you can poll the amplifier at any time and its internal temperature will be reported to the control device.

Over-Current Protection

If an over-current condition occurs in a zone, that zone will shut OFF for 5 seconds and its PROTECTION LEDs will flash ON and OFF. The zone will then turn back ON. If the over-current condition continues the zone will shut OFF for 6 seconds, its PROTECTION LEDs will flash, then it will turn back ON. If the over-current condition continues this process will repeat, with the wait time increasing by 1 second each time. When the wait time reaches 10 seconds the zone will LOCK, the zone's PROTECTION LEDs will continually illuminate and the amplifier must be powered OFF using the front-panel POWER button (or a serial command, if the amp is being controlled via RS-232). **Before turning the amplifier ON again, correct whatever is causing the over-current condition in the zone (speaker impedance too low, volume too high, short-circuit, etc.).**

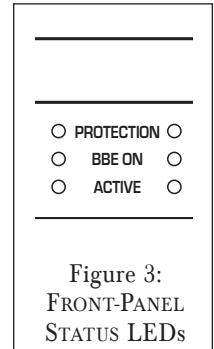

Figure 3:
FRONT-PANEL
STATUS LEDs

Powering the Amplifier

Power Cord (see Figure 4)

The Sonamp 875D SE features a removable IEC power cord. Plug the female end of the power cord into the Power Cord Connector on the amplifier's rear panel and plug the male end into a 20-amp grounded wall socket. DO NOT plug the power cord into an AC outlet on your preamplifier/receiver.

CAUTION: To prevent electric shock, do not defeat the ground prong of the power cord plug.

NOTE: If you need to use an extension cord, use only a heavy-duty (14-gauge or larger) extension cord to avoid starving the amplifier of all the current necessary for full-power operation.

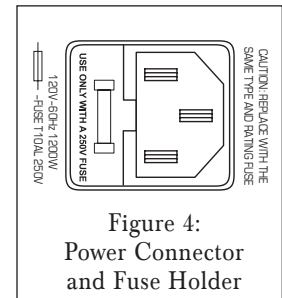

Figure 4:
Power Connector
and Fuse Holder

Replacing the Fuse (see Figure 4)

CAUTION: For continued protection against fire, replace the fuse with only the same type and rating.

1. Remove the power cord from the wall outlet and from the amplifier's Power Cord Connector.
2. Insert a flat-blade screwdriver or similar tool into the empty Power Cord Connector socket and gently pry the fuse holder out of its socket.
3. Install the proper fuse in the fuse holder and replace the fuse holder back into its socket next to the power cord connection.

When the amplifier is operating, the fuse will blow to protect it from possible internal parts failure. NEVER replace the fuse with any size other than that indicated on the rear panel to avoid more serious damage and the risk of fire. Substitution of a larger fuse may create serious damage to internal parts and will void your Sonance warranty.

A.C. ON LED (see Figure 5)

The AC ON LED indicates that the amplifier's power cord is plugged-into a live AC outlet and its POWER button is ON. If the amplifier's AC fuse ever opens, this LED will go out. To use the AUTO-ON feature (see page 12), this LED must remain ON at all times.

ACTIVE LED (see Figure 5)

The amplifier's ACTIVE LED will illuminate whenever any zone is active. Each zone's STATUS INDICATORS (see Figure 3) also contain an ACTIVE LED that will illuminate whenever that particular zone is ON.

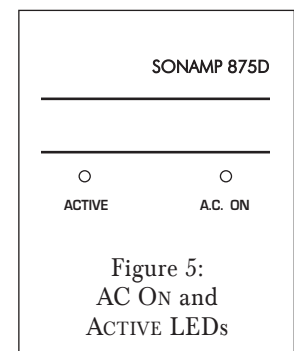

Figure 5:
AC ON and
ACTIVE LEDs

Source Connections (see Figures 6 & 7)

Always use quality high-fidelity interconnect cables such as Sonance MediaLinQ® Bronze Interconnects. If source components are more than 20 feet from the amplifier, use the Sonance LS2 and LR2 Balanced Line-Level Sender and Receiver (sold separately) to avoid signal degradation.

NOTE: Always check local building codes before installing wire in walls or ceilings.

- Connect stereo source components (receiver, preamp, page signal, etc.) that will feed all 8 channels to the BUS LEFT & RIGHT inputs (see Figure 6).
- Connect a mono auxiliary source (page signal, electronic doorbell, etc.) that will feed all 8 channels to the BUS AUX input (see Figure 6).
- Connect zone-specific sources (audio control system zone output, video game, etc.) into the individual channel DIRECT inputs (see Figure 7).
- Connect additional amplifiers to the buffered *Bus Outputs* (see Figure 6). The source connected to the BUS LEFT & RIGHT Inputs appears at the L and R OUTPUTS, and the source connected to the BUS AUX input appears at the AUX OUTPUT.

Input Assignment DIP Switches (see Figure 8)

The Sonamp 875D SE's Input Assignment DIP switches provide the most flexible configuration options of any multichannel amplifier. Settings are changed by setting the switches either OFF (left) or ON (right):

DIRECT: Assign channel to the channel DIRECT input source.

LEFT: Assign channel to the Bus LEFT input source (default for odd-numbered channels)

RIGHT: Assign channel to the Bus RIGHT input source (default for even-numbered channels)

AUX: Assign channel to the Bus Aux input source

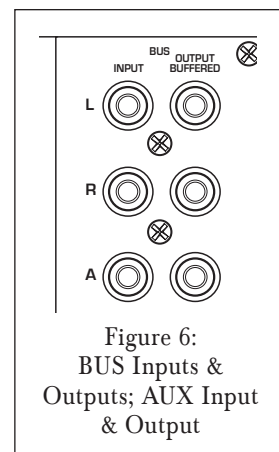

Figure 6:
BUS Inputs &
Outputs; AUX Input
& Output

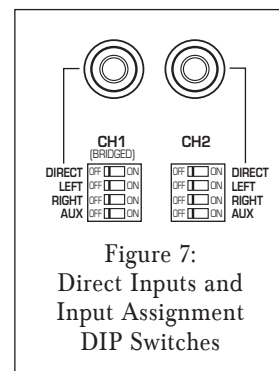

Figure 7:
Direct Inputs and
Input Assignment
DIP Switches

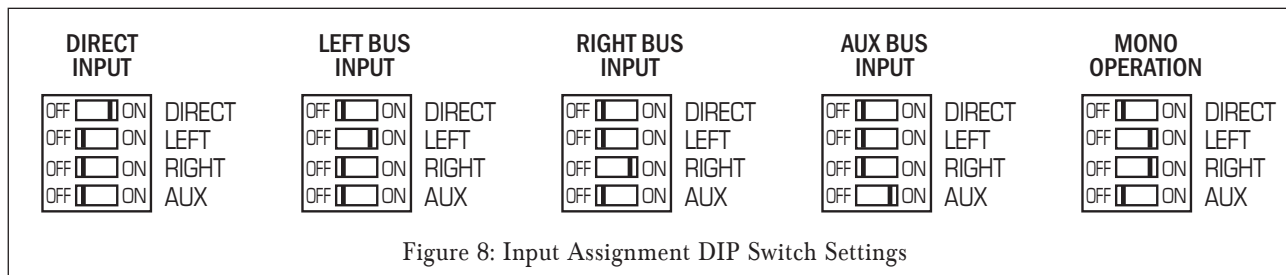

Figure 8: Input Assignment DIP Switch Settings

NOTE: All inputs selected by the DIP switches are summed-together. For example, for mono (L+R) operation, activate both the Bus L and Bus R switches. Take care when setting volume levels, since summed L&R inputs can increase signal gain by up to +6dB.

See pages 18 – 23 for illustrations of different system configurations.

Input Sensitivity Adjustment

There are two ways to adjust the individual channel input sensitivity (volume) on the 875D SE:

- The front panel has recessed adjustment potentiometers (see *Figure 9*). These can be adjusted using a small screwdriver.
- Input sensitivity can also be adjusted by serial command via the amplifier's RS-232 connection (see page 14).

NOTE: When the 875D SE is being serial-controlled, serial VOLUME commands will override the front-panel input sensitivity settings. However, if the front-panel controls are manually adjusted after the serial VOLUME commands are sent, they will override the volume set by the serial commands.

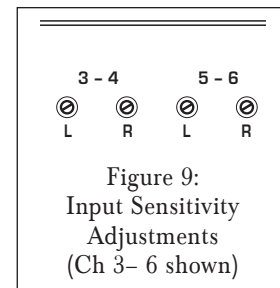

Figure 9:
Input Sensitivity
Adjustments
(Ch 3- 6 shown)

Speaker Connections

IMPORTANT: Always unplug the amplifier's power cord from the wall outlet before making source signal or speaker connections.

Use Good Speaker Wire

For the best sound you should never use thin-gauge speaker wire – it will constrict the sound and diminish bass response. We recommend that you use premium Sonance MediaLinQ speaker cable, which also complies with UL fire rating codes. You may also experiment with audiophile brands of speaker cable and interconnects, but be sure to check local codes governing wire that may be installed within walls or ceilings. Different brands of wire can have different characteristic sounds and some may be more compatible with the sonic “signature” of your various audio system components. Your Sonamp 875D SE is stable with any reputable brand of speaker wire or cable.

Speaker Connections for Stereo Operation (see *Figure 10*)

1. Run speaker wire from each speaker to the amplifier location. We recommend that you mark each wire's positive ('+') and negative ('-') leads, its channel (left or right) and which zone it is from so that you can connect it to the proper speaker terminals.
2. Strip no more than ¼" of insulation from each speaker lead. Twist the strands or tin the exposed wire with solder to ensure that there are no stray strands. (Stray strands that touch each other or touch the amplifier chassis can cause a short-circuit that can damage the amplifier.)
3. The Sonamp 875D SE has removable 4-wire speaker connectors (one for each zone) that can accept wire up to 14AWG. Flip the four levers up to open the connector terminals.
4. Insert the exposed portions of the speaker wires into the terminal openings. Make sure to insert the '+' and '-' leads into the correct openings, as indicated in the chassis markings *below* the connector.
5. After making sure that there are no stray wires touching each other, flip the four levers down to lock the wires in the terminals.

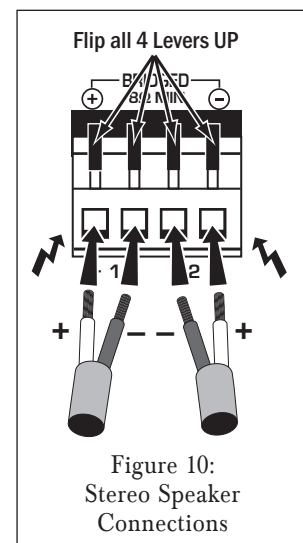

SONAMP® 875D SE 8-CHANNEL AMPLIFIER

6. Press the removable connector into the corresponding zone speaker connector on the amplifier until it locks into place.
 - The removable connectors will only fit one way on the amplifier.

CAUTION: Always provide sufficient slack in wires to avoid tension. Always contain any excess wire to prevent tripping hazards.

Speaker Connections for Bridged Operation (see Figures 11 & 12)

The 875D SE can operate with any pair of channels (zone) in the single-channel bridged mode, which delivers 300 watts RMS into an 8-ohm speaker. **Be sure the speaker is rated to handle this increased output power.**

IMPORTANT: The minimum speaker impedance for Bridged Operation is 8 ohms. Do not operate a zone in the Bridged mode into a speaker that is less than 8 ohms nominal impedance.

1. Move the NORMAL/BRIDGED switch for the zone to the BRIDGED position (see Figure 11).
2. Strip no more than ¼" of insulation from the speaker leads. Twist the strands or tin the exposed wire with solder to ensure that there are no stray strands. (Stray strands that touch each other or touch the amplifier chassis can cause a short-circuit that can damage the amplifier.)
3. The Sonamp 875D SE has a removable 4-wire speaker connector for each zone that can accept wire up to 14AWG. Flip the outer two levers up to open the connector terminals.
4. Insert the single speaker's "+" and "-" speaker leads into the two outer terminal openings on the 4-wire speaker connector. Observe the polarity shown in the chassis markings above the connector (see Figure 12).
5. After making sure that there are no stray wires touching each other, flip the two levers down to lock the wires in the terminal.

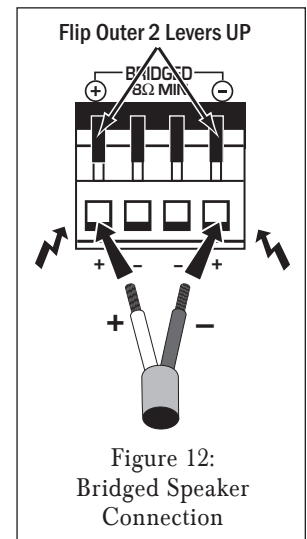
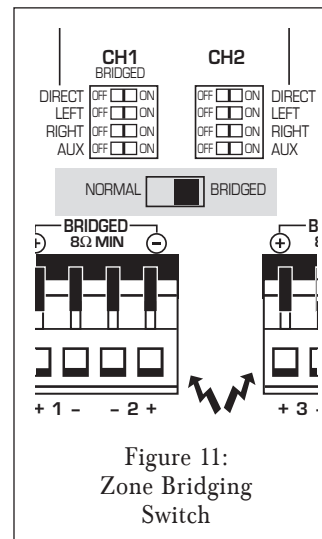

6. Press the removable connector into the corresponding zone speaker connector on the amplifier until it locks into place.
 - The removable connectors will only fit one way on the amplifier.

NOTE: When a zone is bridged, the source connected to the odd-numbered input channel and the INPUT ASSIGNMENT DIP switches for the odd-numbered channel function. The input connected to the even-numbered channel and the switches for the even-numbered channel are disabled.

Auto-On

You can set your 875D SE so that any zone will automatically turn ON when it receives an audio signal, or when it receives a control voltage from an external source (such as a Sonance Navigator Harbor multi-zone controller). Each zone has two Trigger Mode switches located on the rear panel: Auto — zone is turned ON when an audio signal is present, and Volt — zone is turned ON by an external control voltage (see *Figure 14*).

NOTE: Setting both switches ON puts that zone in the Serial control mode, disabling the Auto On feature. (See Serial Control, on page 14.)

Auto (Audio) Trigger Mode

When a zone's AUTO switch is set to the ON position, any audio signal arriving at the zone's active input connectors (as determined by the INPUT ASSIGNMENT DIP SWITCHES, see page 8) will activate the zone for operation. The sensitivity of the zone's AUTO-ON circuit can be increased or decreased by adjusting the AUTO ON level control on the front panel (see *Figure 15*).

- Turning the control clockwise *increases* the sensitivity (*less* voltage is required to trigger the AUTO-ON function).
- Turning the control counter-clockwise *decreases* the sensitivity (*more* voltage is required to trigger the AUTO-ON function).

The AUTO-ON trigger sensitivity ranges from 5mV/ch in the full clockwise position to OFF (AUTO-ON will not trigger) in the full counter-clockwise position.

In the AUTO-ON mode the zone will remain ON for approximately 3 minutes after the audio signal has ceased. This provides ample time to prevent erratic operation from pauses between musical passages or while changing sources.

VOLTAGE Trigger Mode

When a zone's VOLT switch is set to the ON position it can be automatically turned ON by an external trigger voltage that appears at the zone's EXTERNAL TRIGGER INPUT connections (see *Figure 16*).

- The trigger voltage must be between 5V and 24V, either AC or DC.

The 875D SE has individual EXTERNAL TRIGGER INPUT connections for each zone, and an additional EXTERNAL TRIGGER INPUT connection (labeled ALL) that will turn all 4 zones ON from a single voltage trigger.

The EXTERNAL TRIGGER connectors feature flip-up levers similar to the ones used on the speaker connectors:

1. Open the levers for the zone's EXTERNAL TRIGGER inputs.
2. Insert the control wires into the appropriate openings in the connector.
3. Close the levers.

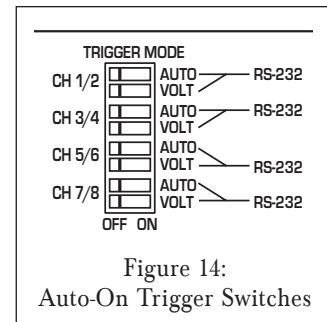

Figure 14:
Auto-On Trigger Switches

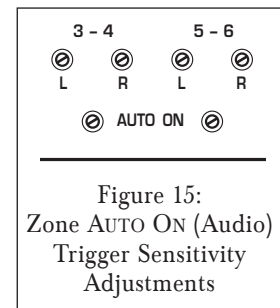

Figure 15:
Zone AUTO ON (Audio)
Trigger Sensitivity
Adjustments

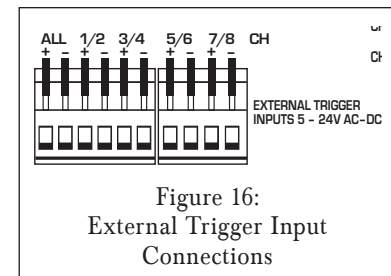

Figure 16:
External Trigger Input
Connections

SONAMP® 875D SE 8-CHANNEL AMPLIFIER

OFF (Bypass) Mode

When a zone's AUTO and VOLT Auto-On Trigger switches are both set in the OFF position, the AUTO-ON circuitry is bypassed and the amplifier's front-panel POWER button will turn all zones ON and OFF simultaneously (see *Figure 2*, on page 5).

BBE® Sound Enhancement

The Sonamp 875D SE incorporates BBE® Sound Enhancement. The BBE process improves the presence and detail of speakers, especially at lower listening volumes, improving the sound quality of your music — especially distributed audio systems playing background music. BBE also restores clarity and definition (or focus) to spoken voices, which makes paging systems easier to understand without having to run them at high volumes. Each zone in the 875D SE has 2 individual switches that let you set the BBE enhancement for that zone to HIGH (+9dB), LOW (+6dB) or OFF (see *Figure 17*):

- If the OFF/ON switch is set to OFF, BBE enhancement is not applied
- If the OFF/ON switch is set to ON, BBE enhancement is applied according to the setting of the LOW/HIGH switch: LOW = +6dB of BBE enhancement; HIGH = +9dB of BBE enhancement.

NOTE: The factory-default setting is +6dB on all zones.

The 875D SE also has a set of BBE CONTROL INPUT connections that allow the BBE enhancement for each zone to be triggered ON and OFF individually by an external control voltage (see *Figure 17*):

- The BBE OFF/ON switch for the zone must be in the OFF position.
- The trigger voltage must be between 5V and 24V, either AC or DC.

The EXTERNAL TRIGGER connectors feature flip-up levers similar to the ones used on the speaker connectors:

1. Open the levers for the zone's EXTERNAL TRIGGER inputs.
2. Insert the control wires into the appropriate openings in the connector.
3. Close the levers.

The front-panel ZONE STATUS LEDs indicate if BBE processing is being applied to a zone (see *Figure 3*, on page 7).

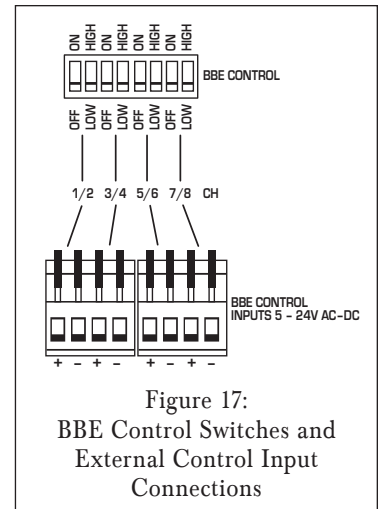

Figure 17:
BBE Control Switches and
External Control Input
Connections

Zone Trigger Outputs

The 875D SE has individual TRIGGER OUTPUT connections for each zone that provide 12V DC whenever the zone is ON (see *Figure 18*). This trigger can be used to control other devices such as Sonance AL2/AS2 automatic secondary switches, other Sonamps or 12V relays.

- The current draw on each zone's TRIGGER OUTPUT connection should not exceed 200mA.

The TRIGGER OUTPUT connectors feature flip-up levers similar to the ones used on the speaker connectors:

1. Open the levers for the zone's TRIGGER OUTPUTS.
2. Insert the control wires into the appropriate openings in the connector (observe the correct "+" and "-" polarity).
3. Close the levers.

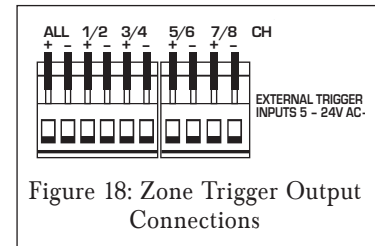

Figure 18: Zone Trigger Output Connections

Serial Control

The 875D SE's RS-232 Control Input (see *Figure 19*) allows many 875D SE functions to be serial-controlled by 3rd-party control systems, and allows many of the amplifier's performance parameters to be monitored in real-time via the 3rd-party controller.

The 875D SE's open architecture allows you to use it with a variety of RS-232 controllers. Specific modules for use with Crestron® and AMX® controllers are available for download at www.sonance.com. Please check the website for information about compatibility with additional controllers.

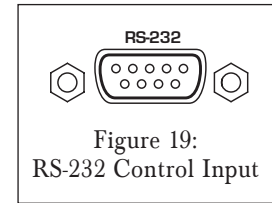

Figure 19: RS-232 Control Input

Connecting the 875D SE to a Serial Control Device

The 875D SE's RS-232 Pinout is: **Pin 2: RXD; Pin 3: TXD; Pin 5: GND.**

Use a null modem cable to connect the 875D SE's RS-232 CONTROL INPUT to a serial control device. To verify the pinout of other serial devices, the TXD pin of an active port will show a negative DC voltage.

NOTE: To connect to a Crestron controller, use the Crestron CNSP-124 cable (available separately from Crestron).

Enabling 875D SE Zone Serial Control

To enable serial control of a zone, both of that zone's AUTO and VOLT Trigger Mode switches must be set in the ON position (see *Figure 20*). Setting a zone to RS-232 disables its rear-panel Auto and Voltage trigger functions — they can only be serial-controlled.

NOTE: Zones not set for RS-232 control can be polled by the control device, but cannot be controlled by the device.

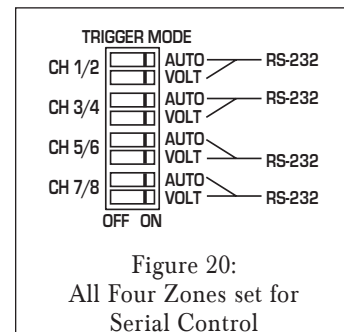

Figure 20:
All Four Zones set for
Serial Control

SONAMP® 875D SE 8-CHANNEL AMPLIFIER

875D SE Serial Commands

Serial Protocol: Baud Rate = 9600, N, 8, 1; single CR

Commands In	Syntax	Parameters	State
Power	:Pxy<cr>	x = Zone 1-4 or G (Global), y = State	0= Off; 1= On
Zone Volume Set	:Vxyyy<cr>	x = Zone 1-4 or G (Global), yyy = Volume 0 - 100	0 (Off) – 100 (Max)
Channel Volume Set	:VCxyyy<cr>	x = Channel 1 - 8 or G (Global), yyy = Volume 0 - 100	0 (Off) – 100 (Max)

NOTE: Issuing a Volume Set command when the amplifier is OFF will pre-set the zone or channel's start-up volume to that level.

Zone Volume Incremental Step	:Vxyy<cr>	x = Zone 1-4 or G (Global), yy = Volume Step Down/Up	-n = Down, +n = Up; n = 1 to 5
Channel Volume Incremental Step:	:VCxyy<cr>	x = Channel 1-8 or G (Global), yy = Volume Step Down/Up	-n = Down, +n = up; n = 1 to 5

NOTE: The 875D SE stores independent settings for Channel and Zone Volume. If Channel Volume commands are sent to a zone that is being controlled with Zone Volume commands (and visa-versa), the volume may initially change to a different level than expected.

Zone Mute	:Mxy<cr>	x = Zone 1-4 or G (Global), y = State	0 = Mute Off; 1= Mute On
Channel Mute	:MCxy<cr>	x = Channel 1 - 8 or G (Global), y = State	0 = Mute Off; 1 = Mute On
BBE Signal Processing	:BPxy<cr>	x = Zone 1-4 or G (Global), y = State	0= Off; 1= On
BBE HI & LO Frequency Boost	:BBxy<cr>	x = Zone 1-4 or G (Global), y = State	0= +6dB; 1=+9dB

NOTE: The echo for this will provide two values (HI and LO)

BBE HI Frequency Boost	:BHxy<cr>	x = Zone 1-4 or G (Global), y = State	0= +6dB; 1=+9dB
BBE LO Frequency Boost	:BLxy<cr>	x = Zone 1-4 or G (Global), y = State	0= +6dB; 1=+9dB

Adding a question-mark character before the carriage return of any of the above commands will turn the command into a query. Additionally, the following unique queries can also be issued:

Queries	Syntax	Parameters	State
Temperature	:TP?<cr>	-	0 – 100 Degrees C
Audio Trigger Input	:ATlx?<cr>	x = Zone 1-4 or G (Global) [see Notes]	0= Off; 1= On
Fault/Protection	:FPx?<cr>	x = Zone 1-4 or G (Global) [see Notes]	0= Normal; 1= Fault
Voltage Trigger Input	:VTlx?<cr>	x = Zone 1-4, A (All) or G (Global) [see Notes]	0= Off; 1= On
Front-Panel Input Control Level	:TVLx?<cr>	x = Channel 1-8 or G (Global) [see Notes]	0 – 100
Firmware Version	:VER?<cr>	-	Version 1.03 or later

(continued on page 16)

Serial Control Notes:

1. The 875D SE will respond to each command with the new value after the command is acted-upon.

Example: Zone 2 volume is 53. If a “:V2+3” (increase Zone 2 volume +3 steps) command is then issued, the 875D SE echoes back (V256) (Zone 2 volume is 56).

2. The 875D SE will respond to invalid commands with “ERR”.

Example: A “:V7?” poll is received (What is Zone 7 volume?). Since there is no Zone 7, the 875D SE echoes back “ERR”.

3. The 875D SE will respond with “N/A” if a recognized command cannot be executed.

Example: Zone 4 is OFF when a “:V4?” (What is Zone 4 volume?) query is received. Since Zone 4 is OFF, the 875D SE echoes back “N/A”.

4a. Any command followed by a “?” will be treated as a Query and will cause the 875D SE to echo back the current state for that zone (z) or channel (c).

Example: Zone 4 is OFF and a “:P4?” query is received. The 875D SE echoes back “P40” (Zone 4 power is OFF).

4b. A command followed by a “G?” will be treated as a Global query and will cause the 875D SE to echo back the current state of each zone or channel.

Example: A “:BPG?” (Is BBE ON or OFF in Zones 1 – 4?) query is received. The 875D SE echoes back:
BP11 (Zone 1 BBE is ON); BP21 (Zone 2 BBE is ON); BP30 (Zone 3 BBE is OFF); BP40 (Zone 4 BBE is OFF)

5. When an over-temperature or fault condition occurs, activating the amplifier’s protection circuits, the 875D SE will issue an unsolicited echo reporting that condition.

Example 1: If the temperature inside the amplifier reaches 68°C, it will issue the unsolicited echo “TP68”.

Example 2: If Zone 1 experiences a fault the amplifier will issue the unsolicited echo “FP1”.

6. When the amplifier is plugged-in it will automatically issue its AMX beacon.

SONAMP® 875D SE 8-CHANNEL AMPLIFIER

Specifications

Number of Channels:	8 (four stereo pairs)
Output Power (Stereo):	75 watts RMS per channel (X8), 0.25% THD, 20Hz – 20kHz, @ 8 ohms; 140 Watts per channel (X8), 0.1% THD, 1kHz, @ 4 ohms
Output Power (Bridged):	300 Watts per channel (X4) @ 8 ohms
Frequency Response:	20Hz – 20kHz, ±1dB
Total Harmonic Distortion:	0.05% (1kHz, 8 ohms); 0.10% (1kHz, 4 ohms)
Signal to Noise Ratio:	-96dB (w/22kHz filter)
Input Sensitivity:	1.5V for 75W RMS Output 1.3V w/BBE ON (+6dB) 1.0V w/BBE ON (+9dB)
Input Impedance:	10k ohms
Maximum Source Input Voltage:	4.0 VAC RMS 3.0V AC RMS w/BBE ON
Loop Output Impedance (Buffered):	100 ohms
Serial Protocol (RS-232 Connection):	9600, N, 8, 1, single CR
Power Consumption:	1,200 Watts
BTU/HR:	850
AC Fuse:	10A (T10AL ~ 250V)
Dimensions (WxHxD):	16½" x 3 ⁷ / ₈ " x 17¼" (419mm x 98mm x 438mm)
Dimensions (w/Rack Ears, WxHxD):	19" x 2½" x 17¼" (483mm x 64mm x 438mm)
Shipping Weight:	47 lbs (21.4kg)

Installation Examples

The illustrations on the following pages show the wide variety of audio and audio/video systems that can be assembled using one or more Sonamp 875D SE amplifiers. Your local authorized Sonance dealer is an expert in audio/video system planning and installation. Sonance strongly recommends that you work with your dealer to ensure that your system is properly planned, assembled and installed.

System 1: Basic Background Music System with Paging Capabilities

Features: Common Music Source for all Four Rooms • Two Zones with Paging Capabilities

Connecting a telephone page output (residential) or microphone preamp output (commercial) to the 875D SE's Aux Bus input and a music source to the LEFT & RIGHT BUS inputs lets you mix a music source with a paging signal. The INPUT ASSIGNMENT DIP SWITCHES let you individually configure each channel to receive or not receive the paging (Aux) input. If you wish to mute the music during paging you can route the amplifier's L/R input connections through a Sonance AL2/S Secondary Source Selector activated by a 12V DC control signal from the paging device.

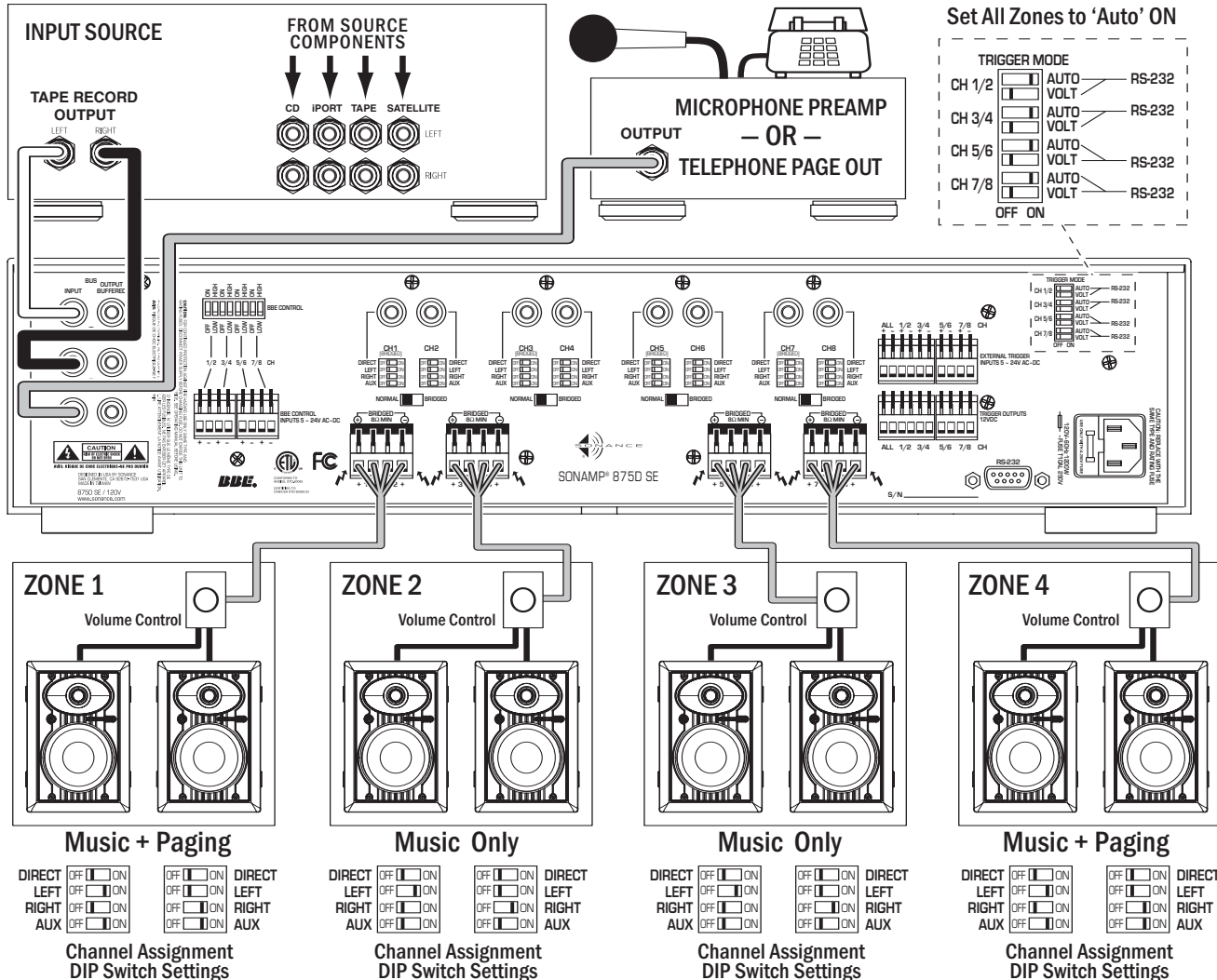

SONAMP® 875D SE 8-CHANNEL AMPLIFIER

System 2: 7.1-Channel Home Theater System

Features: Up to 140W output power per channel (4-ohms) • Allows use of passive in-wall subwoofer

The 875D SE can power all eight channels of a 7.1-channel home theater system while occupying only 2U of rack space. The surround sound processor's preamp outputs feed each channel's DIRECT INPUT CONNECTION, and each channel's INPUT ASSIGNMENT DIP SWITCH is set to DIRECT. For larger home theaters, two 875D SEs can be used with all 16 channels operating in the bridged mode, supplying 300 watts to each of the 8 speakers in the system.

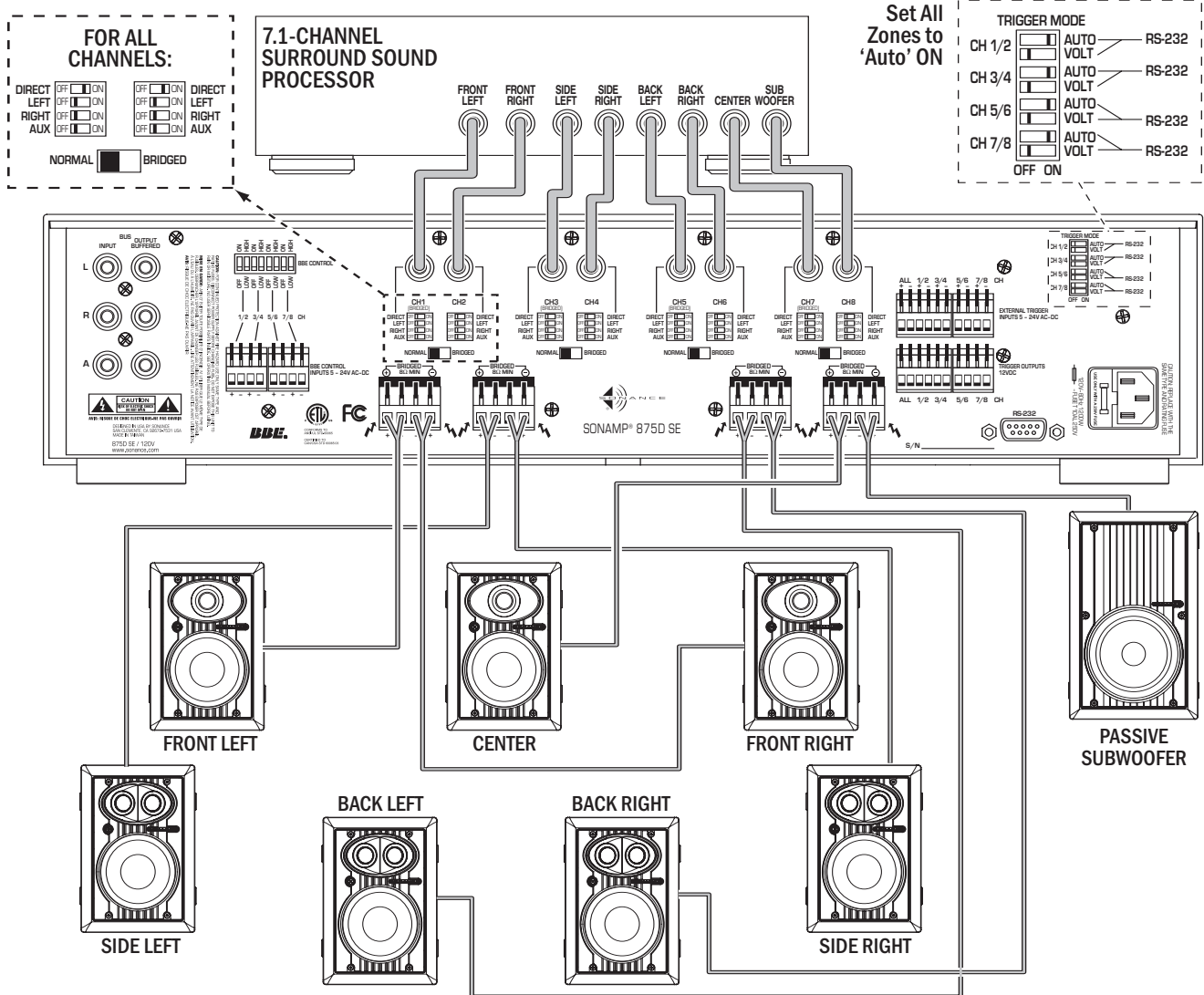

System 3: Multi-Zone System with Controller

Features: Channels automatically activated by controller • Each zone can be controlled by in-zone keypad

The 875D SE is ideal for use with a multi-zone controller like the Sonance Navigator® Harbor. By connecting the Navigator Harbor's Zone Keypad Status + and - terminals to the 875D SE's External Control Input connections, the controller will automatically turn the amplifier's channels ON and OFF as they are needed.

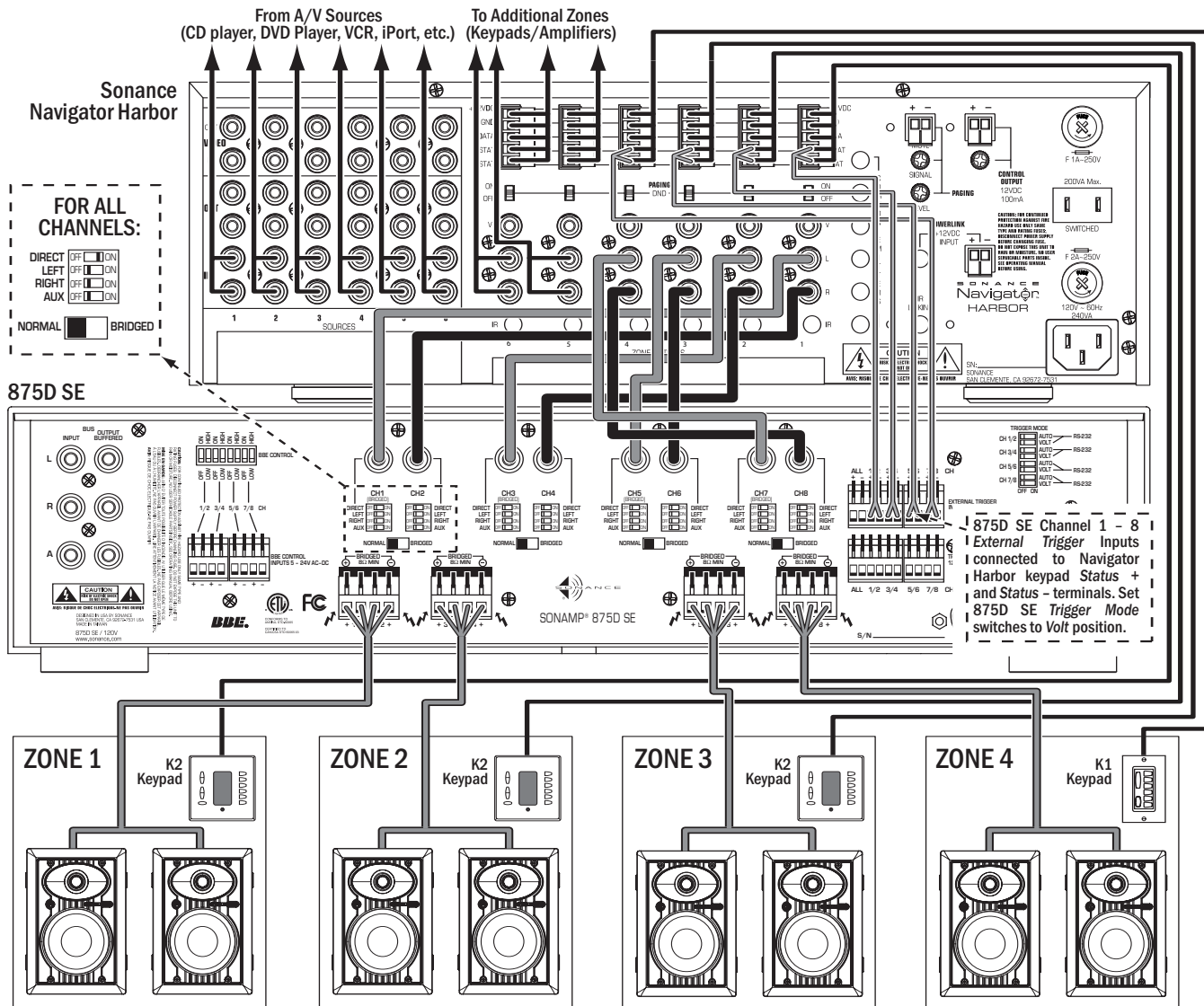

SONAMP® 875D SE 8-CHANNEL AMPLIFIER

System 4: Advanced Multi-Zone System with Central Control System

Features: Serial control of amplifiers • Amplifier parameters can be monitored on controller display

The 875D SE's RS-232 connector allows it to be directly controlled by central whole-home control systems. The system programmer can build the 875D SE's functions into macros, and can display amplifier operating parameters on the controller's touchscreen displays.

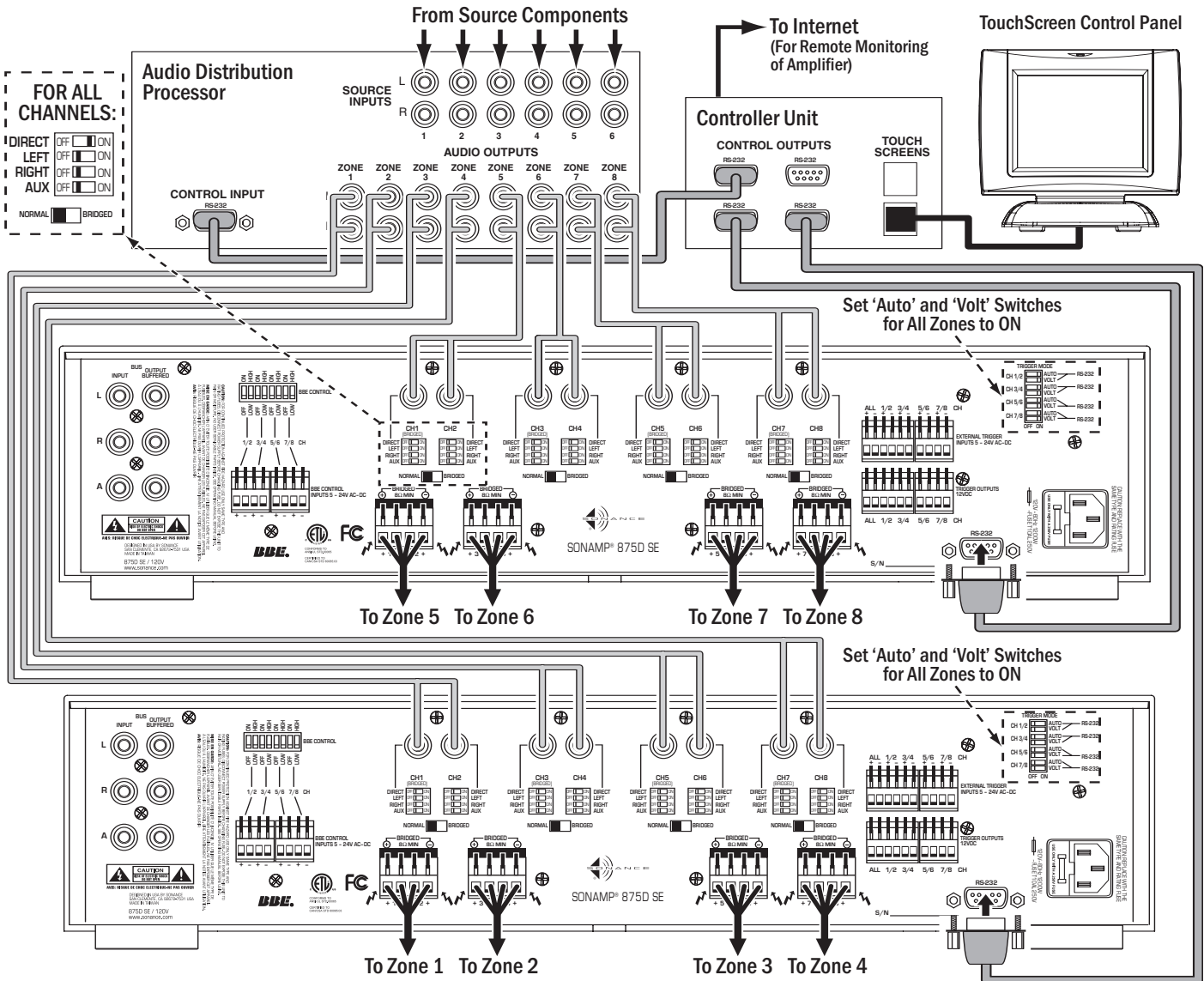

System 5: Automatic Input Switching Between Sources Using an AL2 Selector

Features: Automatically selects iPort when iPod is played • Automatically activates BBE when iPod is played

By feeding two sources through a Sonance AL2 Automatic Secondary Source Selector, the system will automatically select the INPUT B source whenever the iPort/iPod is playing. By connecting the 875D SE's BBE CONTROL OFF/ON switches to the AL2's CONTROL OUTPUT, BBE processing is automatically activated whenever the iPod plays. When the iPod stops playing the input automatically switches back to the CD changer and the 875D SE's BBE processing switches OFF.

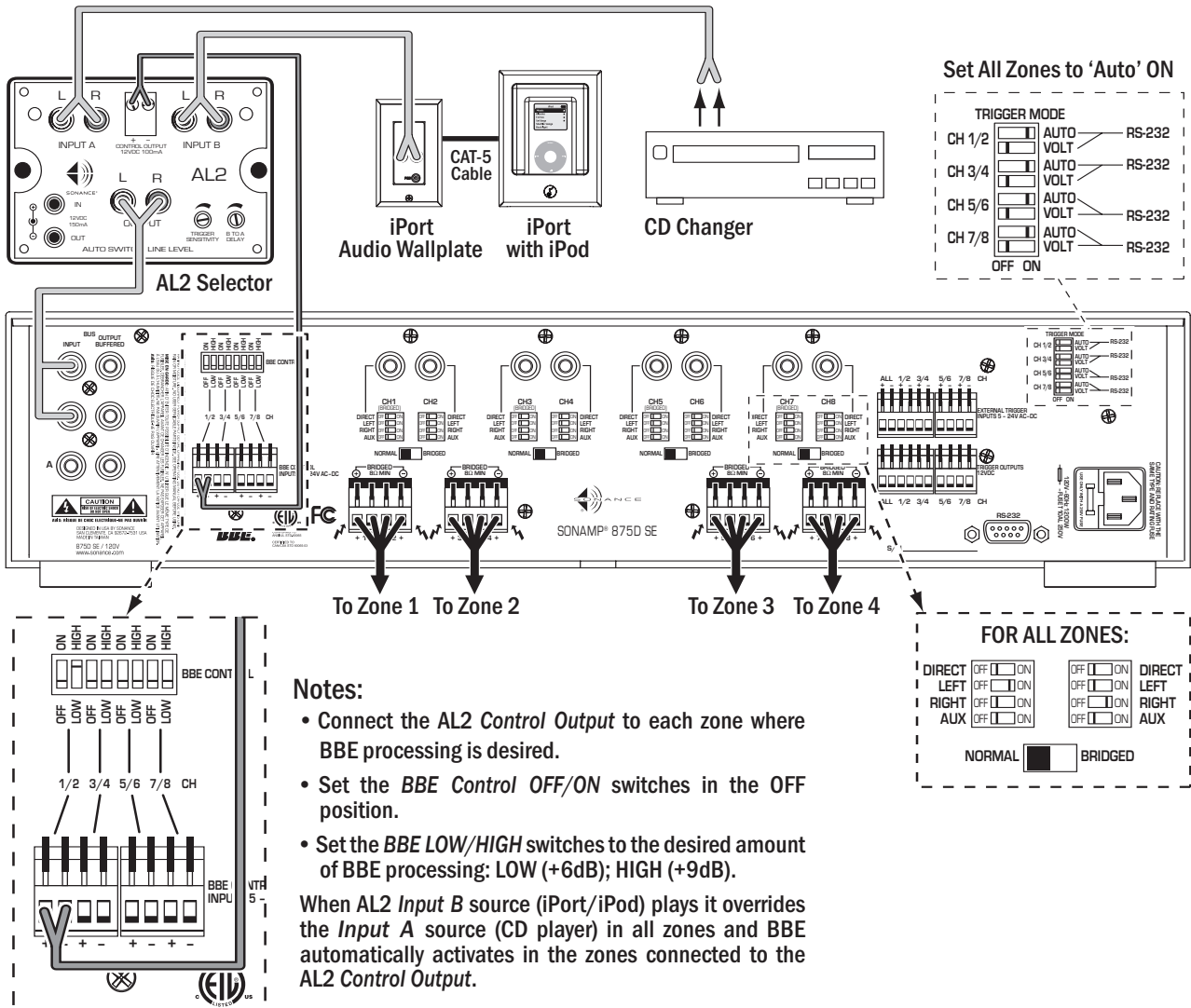

SONAMP® 875D SE 8-CHANNEL AMPLIFIER

System 6: Using a K2 Keypad to Control the 875D SE's BBE Sound Enhancement

Features: User can turn BBE Sound Enhancement ON/OFF from inside the listening zone

The Sonance Navigator K2 Keypad Controller can be used to manually turn the 875D SE's BBE Sound Enhancement ON and OFF in the zone it is controlling. Connect the keypad's RELAY and GROUND terminals to the 875D SE's BBE CONTROL INPUT for that zone and program a button on the keypad's LCD panel to toggle the Relay command ON and OFF. You can even re-label the button on the K2 to say "BBE ON". Set the BBE LOW/HIGH switch for the zone to LOW for +6dB of BBE processing or to HIGH for +9dB of BBE processing. (Leave the zone's BBE ON/OFF switch in the OFF position.)

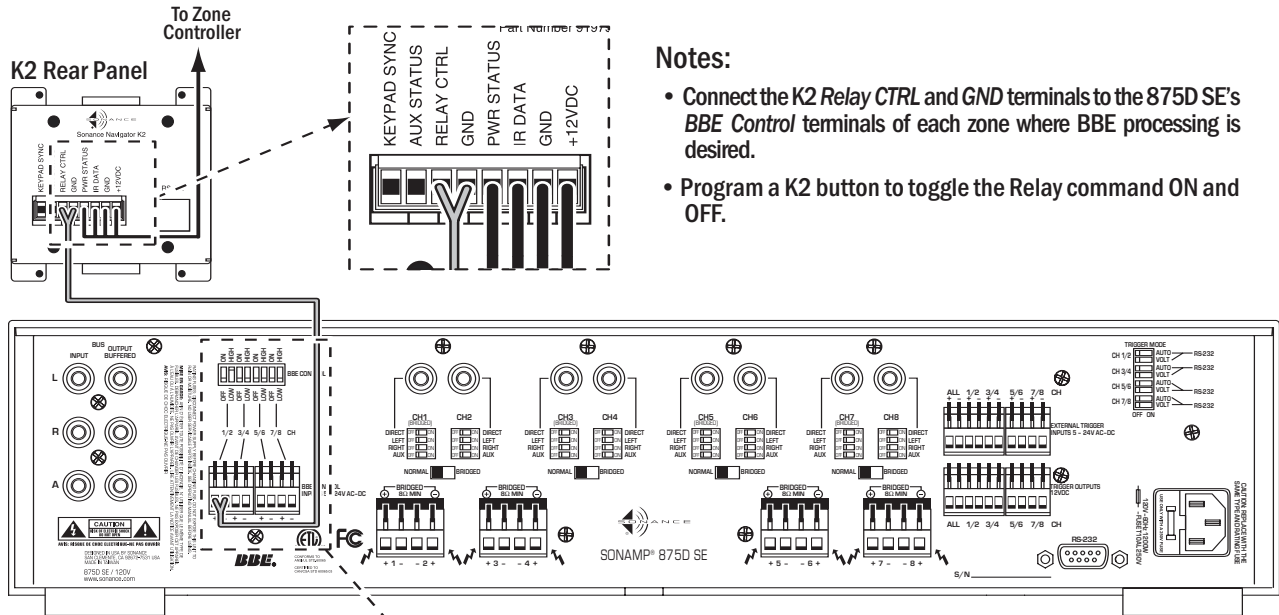

Notes:

- Connect the K2 Relay CTRL and GND terminals to the 875D SE's BBE Control terminals of each zone where BBE processing is desired.
- Program a K2 button to toggle the Relay command ON and OFF.

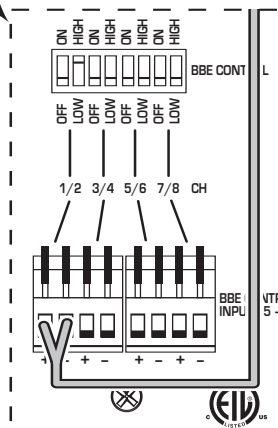

Notes:

- Set the BBE Control OFF/ON switches in the OFF position.
- Set the BBE LOW/HIGH switches to the desired amount of BBE processing: LOW (+6dB); HIGH (+9dB).

Technical Assistance and Service

If you any have questions about the operation or installation of this product, please call our Technical Assistance Department on any business day at (800) 582-0772 or (949) 492-7777; from 7 a.m. to 5 p.m., Pacific Time.

If your product should need repair or service, contact your Sonance Authorized Dealer for help, or use the following procedure:

1. Prior to calling Sonance, note the product's model number, serial number, purchase date, and the name and address of the dealer where you purchased the product.
2. Contact our Technical Assistance Department at the above number(s) and describe the problem the unit is experiencing. If they determine that the product requires service, they will transfer you to our Customer Service Department, who will issue you a Return Authorization (RA) Number.

Important: You must have prior authorization to return your product to Sonance!

3. If you're directed to return the unit to Sonance for repair, pack the unit in its original shipping carton. If needed, you can obtain replacement packaging from us for a small charge. Note: it is best if you place the box into an additional outer "overcarton" before shipment to minimize a chance of theft in shipment. Please include a copy of the original bill of sale inside the package.
4. Contact a package delivery service such as United Parcel Service or Federal Express to arrange prepaid (not collect) shipping. Do not use the U.S. Postal Service.

Important: Freight collect shipments will be refused.

5. Write the Return Authorization Number on the outside of the shipping carton.

6. Ship the packaged unit to:

Quality Assurance Department
Sonance
212 Avenida Fabricante
San Clemente, CA 92672-7531

Limited Warranty Coverage (U.S.A. Only)

Sonance warrants to the original retail purchaser only that this Sonance product will be free from defects in materials and workmanship for a period of five (5) years, provided the product was purchased from a Sonance Authorized Dealer.

Defective products must be shipped, together with proof of purchase, prepaid insured to the Authorized Sonance Dealer from whom they were purchased, or to the Sonance factory at the address listed on this instruction manual. Freight collect shipments will be refused. It is preferable to ship this product in the original shipping container to lessen the chance of transit damage. In any case, the risk or loss or damage in transit is to be borne by the purchaser. If, upon examination at the factory or Authorized Sonance Dealer, it is determined that the unit was defective in materials or workmanship at any time during this warranty period, Sonance or the Authorized Sonance Dealer will, at its option, repair or replace this product at no additional charge, except as set forth below.

If this model is no longer available and can not be repaired effectively, Sonance, at its sole option, may replace the unit with a current model of equal or greater value. In some cases where a new model is substituted, a modification to the mounting surface may be required. If mounting surface modification is required, Sonance assumes no responsibility or liability for such modification. All replaced parts and product become the property of Sonance. Products replaced or repaired under this warranty will be returned to the original retail purchaser, within a reasonable time, freight prepaid.

This Warranty does not include service or parts to repair damage caused by accident, disaster, misuse, abuse, negligence, inadequate packing or shipping procedures, commercial use, voltage inputs in excess of the rated maximum of the unit, or service, repair or modification of the product which has not been authorized or approved by Sonance. This Warranty also excludes normal cosmetic deterioration caused by environmental conditions. This Warranty is in lieu of all other expressed warranties. If the product is defective in materials or workmanship as warranted above, the purchaser's sole remedy shall be repair or replacement as provided above. In no event will Sonance be liable for any incidental or consequential damages arising out of the use or inability to use the product, even if Sonance or a Authorized Sonance Dealer has been advised of the possibility of such damages, or for any claim by any other party.

Some states do not allow the exclusion or limitation of consequential damages, so the above limitation and exclusion may not apply. All implied warranties on the product are limited to the duration of this expressed Warranty. Some states do not allow limitation on the length of an implied warranty. If the original retail purchaser resides in such a state, this limitation does not apply.

EXCLUSIONS AND LIMITATIONS

The warranty set forth above is in lieu of all other warranties, express or implied, of merchantability, fitness for a particular purpose, or otherwise. The warranty is limited to Sonance products registered herein and specifically excludes any damage to loudspeakers and other allied or associated equipment which may result for any reason from use with this product. Sonance shall, in no event, be liable for incidental or consequential damages arising from any breach of this warranty or otherwise. This warranty gives you specific legal rights, and you may have other rights which vary from state to state.

System Notes:



©2007 Sonance. All rights reserved. Sonance and Sonamp are registered trademarks of Dana Innovations.

Digital Power Processing is a trademark of Tripath Technology, Inc.

Crestron is a trademark of Crestron Electronics, Inc. AMX is a trademark of AMX Corporation.

Due to continuous product improvement, all features and specifications are subject to change without notice. For the latest Sonance product specification information visit our website: www.sonance.com

SONANCE • 212 Avenida Fabricante • San Clemente, CA 92672-7531 USA • (800) 582-7777 or (949) 492-7777
FAX: (949) 361-5151 • Technical Support: (800) 582-0772

www.sonance.com

Download from Www.Somanuals.com. All Manuals Search And Download.

33-4162

06/07

Free Manuals Download Website

<http://myh66.com>

<http://usermanuals.us>

<http://www.somanuals.com>

<http://www.4manuals.cc>

<http://www.manual-lib.com>

<http://www.404manual.com>

<http://www.luxmanual.com>

<http://aubethermostatmanual.com>

Golf course search by state

<http://golfingnear.com>

Email search by domain

<http://emailbydomain.com>

Auto manuals search

<http://auto.somanuals.com>

TV manuals search

<http://tv.somanuals.com>