

3

***1 Note for the antenna (aerial) connecting**
If your car antenna (aerial) is an ISO (International Organization for Standardization) type, use the supplied adaptor (2) to connect it. First connect the car antenna (aerial) to the supplied adaptor, then connect it to the antenna (aerial) jack of the master unit.
***2** RCA pin cord (not supplied)
***3** For details on connecting to the parking brake switch cord, see "Connecting the parking brake cord (1)" on the reverse side.
***4** Auxiliary device such as highway navigation device, TV tuner box, etc.

***1 Hinweis zum Anschließen der Antenne**
Wenn Ihre Fahrzeugantenne der ISO-Norm (Internationale Normungsgemeinschaft) entspricht, schließen Sie sie mithilfe des mitgelieferten Adapters (2) an. Verbinden Sie zuerst die Fahrzeugantenne mit dem mitgelieferten Adapter und verbinden Sie diesen dann mit der Antennenbuchse des Hauptgeräts.
***2** Cinchkabel (nicht mitgeliefert)
***3** Informationen zum Anschließen der Parkbremsenschaltung finden Sie unter „Anschließen der Parkbremsenschaltung (1)“ auf der Rückseite.
***4** Zusätzliches Gerät wie ein verstelltes Navigationsgerät, ein Fernsehgerät usw.

***1 Remarque sur le raccordement de l'antenne**
Si votre antenne de voiture est de type ISO (Organisation internationale de normalisation), utilisez l'adaptateur fourni (2) pour la raccorder. Raccordez d'abord l'antenne de votre véhicule à l'adaptateur fourni et, ensuite, à la prise d'antenne de l'appareil principal.
***2** Cordon à fiches RCA (non fourni)
***3** Pour plus de détails sur le raccordement du cordon du capteur du frein à main, reportez-vous à la section « Raccordement du cordon du frein à main (1) » au verso.
***4** Appareil auxiliaire comme un appareil de navigation dissimulé, un tuner TV, etc.

***1 Nota per il collegamento dell'antenna**
Se l'antenna dell'auto è di tipo ISO (International Organization for Standardization), utilizzare l'adattatore (2) in dotazione per collegarla. Collegare prima l'antenna della macchina all'adattatore in dotazione, quindi collegarla alla presa dell'antenna dell'apparecchio principale.
***2** Cavo a pin RCA (non in dotazione)
***3** Per ulteriori informazioni sulla modalità di collegamento del cavo di commutazione del freno a mano, consultare la sezione «Collegamento del cavo del freno a mano (1)» sul lato opposto.
***4** Dispositivo ausiliario quale un dispositivo di navigazione highway, un sintonizzatore TV e così via.

***1 Opmærking bij de antenne-aansluiting**
Indien uw auto is uitgerust met een antenne van het type ISO (International Organization for Standardization), moet u de aansluiting met behulp van de bijgeleverde adapter (2). Sluit eerst de auto-antenne aan op de bijgeleverde adapter en vervolgens de antennestekker op het hoofd toestel.
***2** Tulpestekker (niet bijgeleverd)
***3** Zie "Parkeerremkabel aansluiten (1)" op de achterkant voor meer informatie over het aansluiten op het schakelsoort van de parkeerrem.
***4** Randapparaat, zoals een verborgen navigatieapparaat, televisietoener, enzovoort

Multi Disc Player

- Installation/Connections
- Installation/Anschluss
- Installation/Connexions
- Installazione/Collegamenti
- Montage/Aansluitingen

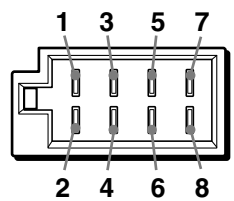
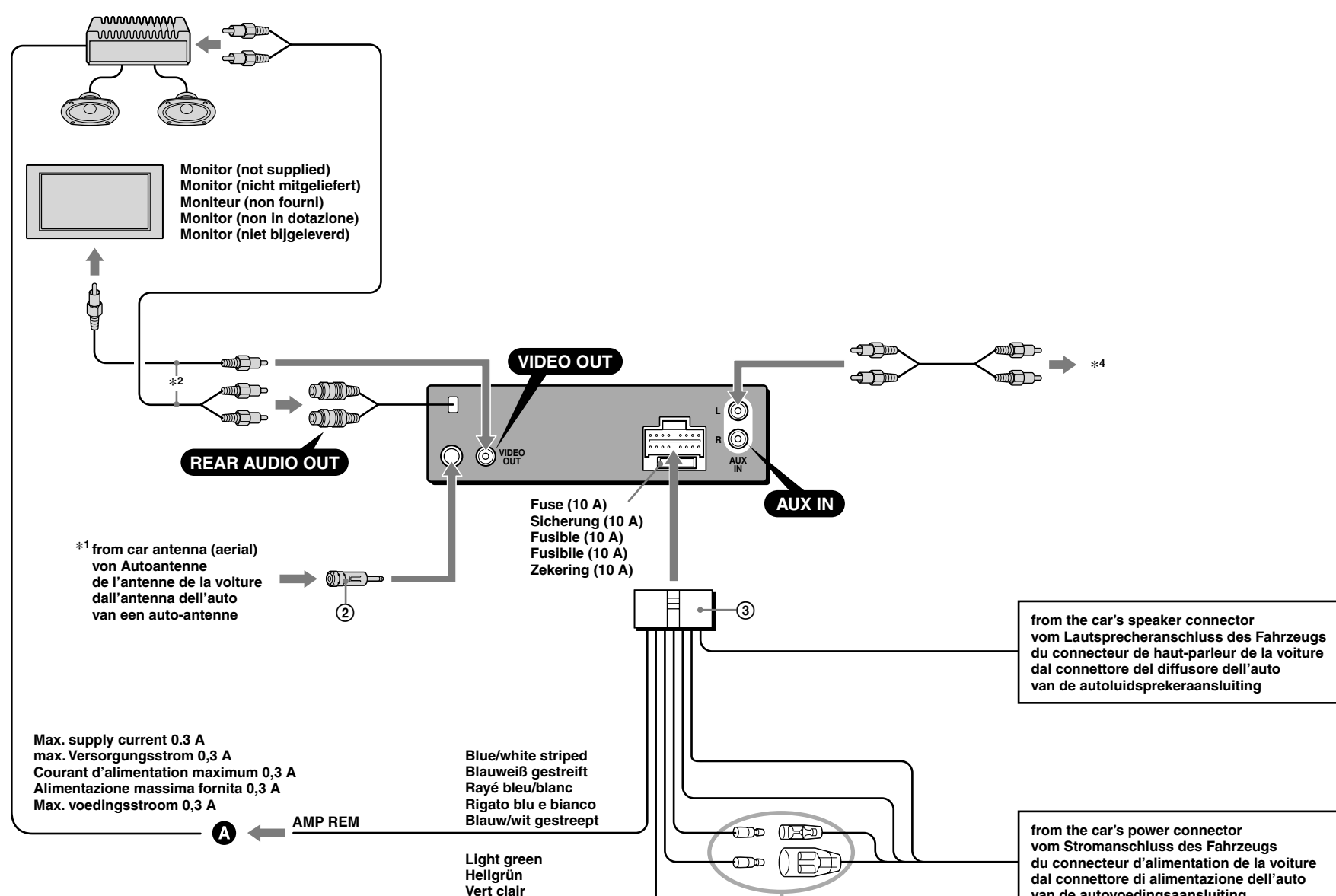

Negative polarity positions 2, 4, 6 and 8 have striped leads. An den negativ gepolten Positionen 2, 4, 6 und 8 befinden sich gestreifte Adern. Les positions à polarité négative 2, 4, 6 et 8 sont dotées de cordons rayés. Le posizioni a polarità negativa 2, 4, 6 e 8 hanno cavi rigati. De posities voor negatieve polariteit (2, 4, 6 en 8) hebben gestreepte kabels.

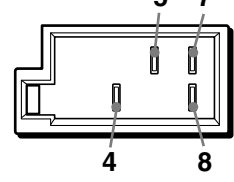

Positions 1, 2, 3 and 6 do not have pins. An Position 1, 2, 3 und 6 befinden sich keine Stifte. Les positions 1, 2, 3 et 6 ne comportent pas de broches. Le posizioni 1, 2, 3 e 6 non hanno pin. De posities 1, 2, 3 en 6 hebben geen pins.

MEX-DV900

© 2008 Sony Corporation Printed in Thailand

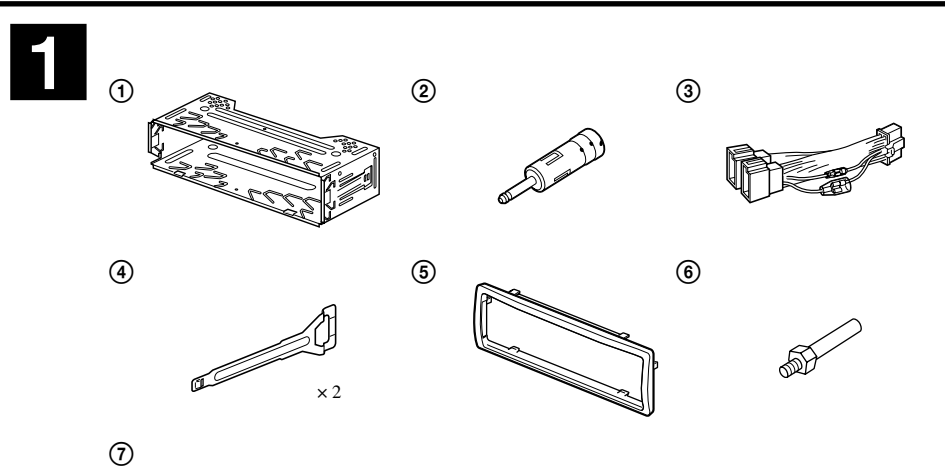

Equipment used in illustrations (not supplied)
In Abbildungen dargestellte Geräte (nicht mitgeliefert)
Appareils utilisés dans les illustrations (non fournis)
Apparecchiatura utilizzata nelle illustrazioni (non in dotazione)
Apparatuur gebruikt in de afbeeldingen (niet bijgeleverd)

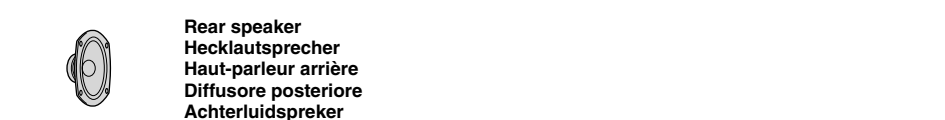
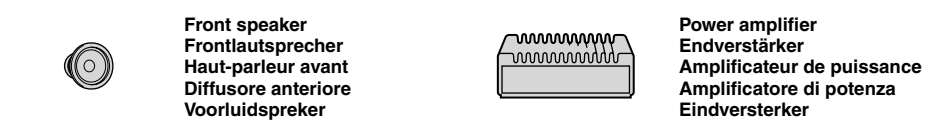

Cautions

- This unit is designed for negative ground (earth) 12 V DC operation only.
- Do not get the leads under a screw, or caught in moving parts (e.g. seat raiting).
- Before making connections, turn the car ignition off to avoid short circuits.
- Connect the power supply lead (2) to the unit and speakers before connecting it to the auxiliary power connector.
- Run all ground (earth) leads to a common ground (earth) point.
- Be sure to insulate any loose connected leads with electrical tape for safety.
- Notes on the power supply lead (yellow)**
 - When connecting this unit in combination with other stereo components, the connected car circuit's rating must be higher than the sum of each component's fuse.
 - When no car circuits are rated high enough, connect the unit directly to the battery.

Parts list

- The numbers in the list are keyed to those in the instructions.
- The bracket (1) and the protection collar (2) are attached to the unit before shipping. Before mounting the unit, use the release keys (3) to remove the bracket (1) and the protection collar (2) from the unit. For details, see "Removing the protection collar and the bracket (1)" on the reverse side of the sheet.
- Always (4) use the release keys (3) for future use as they are also necessary if you remove the unit from your car.

Caution
Handle the bracket (1) carefully to avoid injuring your fingers.

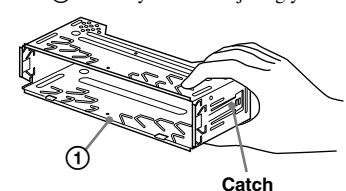

Note
Before installing, make sure that the catches on both sides of the bracket (1) are bent inward 2 mm (3/16 in.). If the catches are straight or bent outwards, the unit will not be installed securely and may spring out.

Connection example

- Be sure to connect the ground (earth) lead before connecting the amplifier.
- The alarm will only sound if the built-in amplifier is used.

Connection diagram

- To AMP REMOTE IN of an optional power amplifier**
This connector is only for amplifiers. Connecting any other system may damage the unit.
- To the parking brake switch cord**

Warning

If you have a power antenna (aerial) without a relay box, connecting this unit with the supplied power supply lead (2) may damage the antenna (aerial).

Notes on the control and power supply leads

- The power antenna (aerial) control lead (blue) supplies +12 V DC when you turn on the tuner, or when you activate the AF (Alternative Frequency) or TA (Traffic Announcement) function.
- When your car has built-in FM/AM/LW antenna (aerial) in the rear-side glass, connect the power antenna (aerial) control lead (blue) or the accessory power supply lead (red) to the power terminal of the existing antenna (aerial) booster. For details, consult your dealer.
- A power antenna (aerial) without a relay box cannot be used with this unit.

Memory lead connection
When the yellow power supply lead is connected, power will always be supplied to the memory circuit even when the ignition switch is turned off.

Notes on speaker connection

- Before connecting the speakers, turn the unit off.
- Use speakers with an impedance of 4 to 8 ohms, and with adequate power handling capacities to avoid its damage.
- Do not connect the speaker terminals to the car chassis, or connect the terminals of the right speakers with the terminals of the left speakers.
- Do not connect the ground (earth) lead of this unit to the negative (-) terminal of the speaker.
- Do not attempt to connect the speakers in parallel.
- Connect only passive speakers. Connecting active speakers (with built-in amplifiers) to the speaker terminals may damage the unit.
- To avoid a malfunction, do not use the built-in speaker leads installed in your car if the unit shares a common negative (-) lead for the right and left speakers.
- Do not connect the unit's speaker leads to each other.
- If speaker and amplifier are not connected correctly, "FAILURE" appears in the display. In this case, make sure the speaker and amplifier are connected correctly.
- If you are to use the monitor for the rear seats, connect the parking brake switch cord to the ground (earth).

How to connect the power supply lead

- When the yellow power supply lead is connected, power will always be supplied to the memory circuit even when the ignition switch is turned off.
- When your car has built-in FM/AM/LW antenna (aerial) in the rear-side glass, connect the power antenna (aerial) control lead (blue) or the accessory power supply lead (red) to the power terminal of the existing antenna (aerial) booster. For details, consult your dealer.
- A power antenna (aerial) without a relay box cannot be used with this unit.

Memory lead connection
When the yellow power supply lead is connected, power will always be supplied to the memory circuit even when the ignition switch is turned off.

Notes on speaker connection

- Before connecting the speakers, turn the unit off.
- Use speakers with an impedance of 4 to 8 ohms, and with adequate power handling capacities to avoid its damage.
- Do not connect the speaker terminals to the car chassis, or connect the terminals of the right speakers with the terminals of the left speakers.
- Do not connect the ground (earth) lead of this unit to the negative (-) terminal of the speaker.
- Do not attempt to connect the speakers in parallel.
- Connect only passive speakers. Connecting active speakers (with built-in amplifiers) to the speaker terminals may damage the unit.
- To avoid a malfunction, do not use the built-in speaker leads installed in your car if the unit shares a common negative (-) lead for the right and left speakers.
- Do not connect the unit's speaker leads to each other.
- If speaker and amplifier are not connected correctly, "FAILURE" appears in the display. In this case, make sure the speaker and amplifier are connected correctly.
- If you are to use the monitor for the rear seats, connect the parking brake switch cord to the ground (earth).

How to connect the power supply lead

- When the yellow power supply lead is connected, power will always be supplied to the memory circuit even when the ignition switch is turned off.
- When your car has built-in FM/AM/LW antenna (aerial) in the rear-side glass, connect the power antenna (aerial) control lead (blue) or the accessory power supply lead (red) to the power terminal of the existing antenna (aerial) booster. For details, consult your dealer.
- A power antenna (aerial) without a relay box cannot be used with this unit.

Vorsichtsmaßnahmen

- Dieses Gerät ist ausschließlich für den Betrieb bei 12 V Gleichstrom (negative Erdung) bestimmt.
- Achten Sie darauf, dass die Kabel nicht unter einer Schraube oder zwischen beweglichen Teilen wie z. B. in einer Sitzschiene eingeklemmt werden.
- Schalten Sie, bevor Sie irgendwelche Anschlüsse vornehmen, die Zündung des Fahrzeuges aus, um Kurzschlüsse zu vermeiden.
- Verbinden Sie das Stromversorgungs-kabel (2) mit dem Gerät und den Lautsprechern, bevor Sie es mit dem Hilfsstromanschluss verbinden.
- Schließen Sie alle Erdungskabel an einen gemeinsamen Massepunkt an.
- An Sicherheitsgründen müssen alle Lösen, nicht angeschlossenen Drähte mit Isolierband abgedeckt werden.
- Hinweise zum Stromversorgungs-kabel (gelb)**
 - Wenn Sie dieses Gerät zusammen mit anderen Stereokomponenten anschließen, muss der Autostromkreis, an den die Geräte angeschlossen sind, eine höhere Leistung aufweisen als die Summe der Sicherungen der einzelnen Komponenten.
 - Wenn kein Autostromkreis eine so hohe Leistung aufweist, schließen Sie das Gerät direkt an die Batterie an.

Teilliste

- Die Nummern in der Liste sind dieselben wie im Erläuterungstext.
- Die Halterung (1) und die Schutzumrandung (2) werden vor dem Ausliefern an Gerät angebracht. Bevor Sie das Gerät montieren, nehmen Sie die Halterung (1) und die Schutzumrandung (2) mithilfe der Löseschlüssel (3) bzw. durch die Öffnungen (4) ab.
- Benutzen Sie die Löseschlüssel (3) für den späteren Gebrauch auf. Sie werden z. B. benötigt, wenn Sie das Gerät aus dem Fahrzeug ausbauen wollen.

Vorsicht
Seien Sie beim Umgang mit der Halterung (1) vorsichtig, damit Sie sich nicht die Hände verletzen.

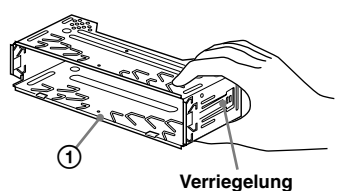

Note
Before installing, make sure that the catches on both sides of the bracket (1) are bent inward 2 mm (3/16 in.). If the catches are straight or bent outwards, the unit will not be installed securely and may spring out.

Anschlussbeispiel

- Be sure to connect the ground (earth) lead before connecting the amplifier.
- The alarm will only sound if the built-in amplifier is used.

Anschlussdiagramm

- An AMP REMOTE IN des gesondert erhältlichen Endverstärkers**
Dieser Anschluss ist ausschließlich für Verstärker gedacht. Schließen Sie nichts anderes daran an. Andernfalls kann das Gerät beschädigt werden.
- An die Parkbremsenschaltung**

Warnung

If you have a power antenna (aerial) without a relay box, connecting this unit with the supplied power supply lead (2) may damage the antenna (aerial).

Notes on the control and power supply leads

- The power antenna (aerial) control lead (blue) supplies +12 V DC when you turn on the tuner, or when you activate the AF (Alternative Frequency) or TA (Traffic Announcement) function.
- When your car has built-in FM/AM/LW antenna (aerial) in the rear-side glass, connect the power antenna (aerial) control lead (blue) or the accessory power supply lead (red) to the power terminal of the existing antenna (aerial) booster. For details, consult your dealer.
- A power antenna (aerial) without a relay box cannot be used with this unit.

Memory lead connection
When the yellow power supply lead is connected, power will always be supplied to the memory circuit even when the ignition switch is turned off.

Notes on speaker connection

- Before connecting the speakers, turn the unit off.
- Use speakers with an impedance of 4 to 8 ohms, and with adequate power handling capacities to avoid its damage.
- Do not connect the speaker terminals to the car chassis, or connect the terminals of the right speakers with the terminals of the left speakers.
- Do not connect the ground (earth) lead of this unit to the negative (-) terminal of the speaker.
- Do not attempt to connect the speakers in parallel.
- Connect only passive speakers. Connecting active speakers (with built-in amplifiers) to the speaker terminals may damage the unit.
- To avoid a malfunction, do not use the built-in speaker leads installed in your car if the unit shares a common negative (-) lead for the right and left speakers.
- Do not connect the unit's speaker leads to each other.
- If speaker and amplifier are not connected correctly, "FAILURE" appears in the display. In this case, make sure the speaker and amplifier are connected correctly.
- If you are to use the monitor for the rear seats, connect the parking brake switch cord to the ground (earth).

How to connect the power supply lead

- When the yellow power supply lead is connected, power will always be supplied to the memory circuit even when the ignition switch is turned off.
- When your car has built-in FM/AM/LW antenna (aerial) in the rear-side glass, connect the power antenna (aerial) control lead (blue) or the accessory power supply lead (red) to the power terminal of the existing antenna (aerial) booster. For details, consult your dealer.
- A power antenna (aerial) without a relay box cannot be used with this unit.

Memory lead connection
When the yellow power supply lead is connected, power will always be supplied to the memory circuit even when the ignition switch is turned off.

Notes on speaker connection

- Before connecting the speakers, turn the unit off.
- Use speakers with an impedance of 4 to 8 ohms, and with adequate power handling capacities to avoid its damage.
- Do not connect the speaker terminals to the car chassis, or connect the terminals of the right speakers with the terminals of the left speakers.
- Do not connect the ground (earth) lead of this unit to the negative (-) terminal of the speaker.
- Do not attempt to connect the speakers in parallel.
- Connect only passive speakers. Connecting active speakers (with built-in amplifiers) to the speaker terminals may damage the unit.
- To avoid a malfunction, do not use the built-in speaker leads installed in your car if the unit shares a common negative (-) lead for the right and left speakers.
- Do not connect the unit's speaker leads to each other.
- If speaker and amplifier are not connected correctly, "FAILURE" appears in the display. In this case, make sure the speaker and amplifier are connected correctly.
- If you are to use the monitor for the rear seats, connect the parking brake switch cord to the ground (earth).

How to connect the power supply lead

- When the yellow power supply lead is connected, power will always be supplied to the memory circuit even when the ignition switch is turned off.
- When your car has built-in FM/AM/LW antenna (aerial) in the rear-side glass, connect the power antenna (aerial) control lead (blue) or the accessory power supply lead (red) to the power terminal of the existing antenna (aerial) booster. For details, consult your dealer.
- A power antenna (aerial) without a relay box cannot be used with this unit.

Précautions

- Cet appareil est conçu pour fonctionner sur un courant continu de 12 V, avec masse négative.
- Evitez de coincer les câbles sous des vis ou dans des pièces mobiles (par exemple, armature de siège).
- Avant d'effectuer des raccordements, coupez le moteur pour éviter les courts-circuits.
- Branchez le câble d'alimentation (2) sur l'appareil et les haut-parleurs avant de le brancher sur le connecteur d'alimentation auxiliaire.
- Rassemblez tous les câbles de terre en un point de masse commun.
- Veillez à isoler tout câble ou câble non connecté avec du ruban isolant.
- Remarques sur le câble d'alimentation (jaune)**
 - Lorsque cet appareil est raccorcé à d'autres équipements stéréo, la valeur nominale des circuits du véhicule raccorcés doit être supérieure à la somme des fusibles de chaque élément.
 - Si aucun circuit de la voiture n'est assez puissant, raccordez directement l'appareil à la batterie.

Liste des composants

- Les numéros de la liste correspondent à ceux des instructions.
- Le support (1) et le tour de protection (2) sont fixés à l'appareil en usine. Avant le montage de l'appareil, utilisez les clés de déblocage (3) pour détacher le support (1) et le tour de protection (2) de l'appareil.
- Pour de plus amples informations, reportez-vous à la section « Retrait du tour de protection et du support (1) » au verso de la feuille.
- Conservez les clés de déblocage (3) pour un utilisation ultérieure car vous en aurez éventuellement besoin pour retirer l'appareil de votre véhicule.

Avertissement
Manipulez le support (1) avec soin pour éviter de vous blesser aux doigts.

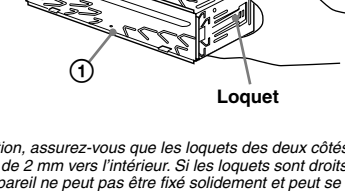

Note
Before installing, make sure that the catches on both sides of the bracket (1) are bent inward 2 mm (3/16 in.). If the catches are straight or bent outwards, the unit will not be installed securely and may spring out.

Exemple de raccordement

- Be sure to connect the ground (earth) lead before connecting the amplifier.
- The alarm will only sound if the built-in amplifier is used.

Schémas de raccordement

- An AMP REMOTE IN of an amplifier of power on option**
This connector is only for amplifiers. Connecting any other system may damage the unit.
- Vers le cordon du capteur du frein à main**

Avertissement

If you have a power antenna (aerial) without a relay box, connecting this unit with the supplied power supply lead (2) may damage the antenna (aerial).

Notes on the control and power supply leads

- The power antenna (aerial) control lead (blue) supplies +12 V DC when you turn on the tuner, or when you activate the AF (Alternative Frequency) or TA (Traffic Announcement) function.
- When your car has built-in FM/AM/LW antenna (aerial) in the rear-side glass, connect the power antenna (aerial) control lead (blue) or the accessory power supply lead (red) to the power terminal of the existing antenna (aerial) booster. For details, consult your dealer.
- A power antenna (aerial) without a relay box cannot be used with this unit.

Memory lead connection
When the yellow power supply lead is connected, power will always be supplied to the memory circuit even when the ignition switch is turned off.

Notes on speaker connection

- Before connecting the speakers, turn the unit off.
- Use speakers with an impedance of 4 to 8 ohms, and with adequate power handling capacities to avoid its damage.
- Do not connect the speaker terminals to the car chassis, or connect the terminals of the right speakers with the terminals of the left speakers.
- Do not connect the ground (earth) lead of this unit to the negative (-) terminal of the speaker.
- Do not attempt to connect the speakers in parallel.
- Connect only passive speakers. Connecting active speakers (with built-in amplifiers) to the speaker terminals may damage the unit.
- To avoid a malfunction, do not use the built-in speaker leads installed in your car if the unit shares a common negative (-) lead for the right and left speakers.
- Do not connect the unit's speaker leads to each other.
- If speaker and amplifier are not connected correctly, "FAILURE" appears in the display. In this case, make sure the speaker and amplifier are connected correctly.
- If you are to use the monitor for the rear seats, connect the parking brake switch cord to the ground (earth).

How to connect the power supply lead

- When the yellow power supply lead is connected, power will always be supplied to the memory circuit even when the ignition switch is turned off.
- When your car has built-in FM/AM/LW antenna (aerial) in the rear-side glass, connect the power antenna (aerial) control lead (blue) or the accessory power supply lead (red) to the power terminal of the existing antenna (aerial) booster. For details, consult your dealer.
- A power antenna (aerial) without a relay box cannot be used with this unit.

Memory lead connection
When the yellow power supply lead is connected, power will always be supplied to the memory circuit even when the ignition switch is turned off.

Notes on speaker connection

- Before connecting the speakers, turn the unit off.
- Use speakers with an impedance of 4 to 8 ohms, and with adequate power handling capacities to avoid its damage.
- Do not connect the speaker terminals to the car chassis, or connect the terminals of the right speakers with the terminals of the left speakers.
- Do not connect the ground (earth) lead of this unit to the negative (-) terminal of the speaker.
- Do not attempt to connect the speakers in parallel.
- Connect only passive speakers. Connecting active speakers (with built-in amplifiers) to the speaker terminals may damage the unit.
- To avoid a malfunction, do not use the built-in speaker leads installed in your car if the unit shares a common negative (-) lead for the right and left speakers.
- Do not connect the unit's speaker leads to each other.
- If speaker and amplifier are not connected correctly, "FAILURE" appears in the display. In this case, make sure the speaker and amplifier are connected correctly.
- If you are to use the monitor for the rear seats, connect the parking brake switch cord to the ground (earth).

How to connect the power supply lead

- When the yellow power supply lead is connected, power will always be supplied to the memory circuit even when the ignition switch is turned off.
- When your car has built-in FM/AM/LW antenna (aerial) in the rear-side glass, connect the power antenna (aerial) control lead (blue) or the accessory power supply lead (red) to the power terminal of the existing antenna (aerial) booster. For details, consult your dealer.
- A power antenna (aerial) without a relay box cannot be used with this unit.

Attenzione

- Questo apparecchio è stato progettato per l'uso solo a 12 V CC con massa negativa.
- Evitare che i cavi rimangano bloccati da una vite o incastrati nelle parti mobili (ad esempio nelle guide scorrevoli dei sedili).
- Prima di effettuare i collegamenti, spegnere il motore dell'automobile onde evitare di causare cortocircuiti.
- Branchez le câble d'alimentation (2) sur l'appareil et les haut-parleurs avant de le brancher sur le connecteur d'alimentation auxiliaire.
- Rassemblez tous les câbles de terre en un point de masse commun.
- Veillez à isoler tout câble ou câble non connecté avec du ruban isolant.
- Remarques sur le câble d'alimentation (jaune)**
 - Lorsque cet appareil est raccorcé à d'autres équipements stéréo, la valeur nominale des circuits du véhicule raccorcés doit être supérieure à la somme des fusibles de chaque élément.
 - Si aucun circuit de la voiture n'est assez puissant, raccordez directement l'appareil à la batterie.

Elenco dei componenti

- I numeri nella lista corrispondono a quelli riportati nelle istruzioni.
- La staffa (1) e la cornice protettiva (2) vengono applicati all'unità in fabbrica. Prima di installare l'unità, utilizzare le chiavi di rilascio (3) per rimuovere la staffa (1) e la cornice protettiva (2) dall'apparecchio. Per ulteriori informazioni, vedere "Rimozione della staffa e della cornice protettiva (2)" sul lato opposto del foglio.
- Conservare le chiavi di rilascio (3) per un uso futuro in quanto sono necessarie per rimuovere l'unità dall'auto.

Attenzione
Maneggiare la staffa (1) con cautela per evitare di ferirsi le mani.

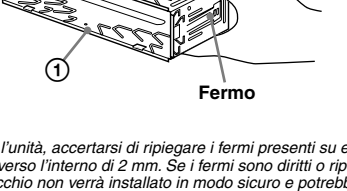

Note
Prima di installare l'unità, accertarsi di ripiegare i fermi presenti su entrambi i lati della staffa (1) verso l'interno di 2 mm. Se i fermi sono dritti o spingati verso l'esterno, l'apparecchio non verrà installato in modo sicuro e potrebbe fuoriuscire.

Esempio di collegamento

- Be sure to connect the ground (earth) lead before connecting the amplifier.
- The alarm will only sound if the built-in amplifier is used.

Schema di collegamento

- A AMP REMOTE IN of an amplifier of power on option**
This connector is only for amplifiers. Connecting any other system may damage the unit.
- Al cavo di commutazione del freno a mano**

Avvertenza

If you have a power antenna (aerial) without a relay box, connecting this unit with the supplied power supply lead (2) may damage the antenna (aerial).

Notes on the control and power supply leads

- The power antenna (aerial) control lead (blue) supplies +12 V DC when you turn on the tuner, or when you activate the AF (Alternative Frequency) or TA (Traffic Announcement) function.
- When your car has built-in FM/AM/LW antenna (aerial) in the rear-side glass, connect the power antenna (aerial) control lead (blue) or the accessory power supply lead (red) to the power terminal of the existing antenna (aerial) booster. For details, consult your dealer.
- A power antenna (aerial) without a relay box cannot be used with this unit.

Memory lead connection
When the yellow power supply lead is connected, power will always be supplied to the memory circuit even when the ignition switch is turned off.

Notes on speaker connection

- Before connecting the speakers, turn the unit off.
- Use speakers with an impedance of 4 to 8 ohms, and with adequate power handling capacities to avoid its damage.
- Do not connect the speaker terminals to the car chassis, or connect the terminals of the right speakers with the terminals of the left speakers.
- Do not connect the ground (earth) lead of this unit to the negative (-) terminal of the speaker.
- Do not attempt to connect the speakers in parallel.
- Connect only passive speakers. Connecting active speakers (with built-in amplifiers) to the speaker terminals may damage the unit.
- To avoid a malfunction, do not use the built-in speaker leads installed in your car if the unit shares a common negative (-) lead for the right and left speakers.
- Do not connect the unit's speaker leads to each other.
- If speaker and amplifier are not connected correctly, "FAILURE" appears in the display. In this case, make sure the speaker and amplifier are connected correctly.
- If you are to use the monitor for the rear seats, connect the parking brake switch cord to the ground (earth).

How to connect the power supply lead

- When the yellow power supply lead is connected, power will always be supplied to the memory circuit even when the ignition switch is turned off.
- When your car has built-in FM/AM/LW antenna (aerial) in the rear-side glass, connect the power antenna (aerial) control lead (blue) or the accessory power supply lead (red) to the power terminal of the existing antenna (aerial) booster. For details, consult your dealer.
- A power antenna (aerial) without a relay box cannot be used with this unit.

Memory lead connection
When the yellow power supply lead is connected, power will always be supplied to the memory circuit even when the ignition switch is turned off.

Notes on speaker connection

- Before connecting the speakers, turn the unit off.
- Use speakers with an impedance of 4 to 8 ohms, and with adequate power handling capacities to avoid its damage.
- Do not connect the speaker terminals to the car chassis, or connect the terminals of the right speakers with the terminals of the left speakers.
- Do not connect the ground (earth) lead of this unit to the negative (-) terminal of the speaker.
- Do not attempt to connect the speakers in parallel.
- Connect only passive speakers. Connecting active speakers (with built-in amplifiers) to the speaker terminals may damage the unit.
- To avoid a malfunction, do not use the built-in speaker leads installed in your car if the unit shares a common negative (-) lead for the right and left speakers.
- Do not connect the unit's speaker leads to each other.
- If speaker and amplifier are not connected correctly, "FAILURE" appears in the display. In this case, make sure the speaker and amplifier are connected correctly.
- If you are to use the monitor for the rear seats, connect the parking brake switch cord to the ground (earth).

How to connect the power supply lead

- When the yellow power supply lead is connected, power will always be supplied to the memory circuit even when the ignition switch is turned off.
- When your car has built-in FM/AM/LW antenna (aerial) in the rear-side glass, connect the power antenna (aerial) control lead (blue) or the accessory power supply lead (red) to the power terminal of the existing antenna (aerial) booster. For details, consult your dealer.
- A power antenna (aerial) without a relay box cannot be used with this unit.

Let op

- Dit apparaat is ontworpen voor gebruik op een auto-accu van 12 V gelijkstroom, negatief geaard.
- Zorg ervoor dat de draden niet onder een schroef of tussen bewegende onderdelen (b.v. zetelrâ) terechtkomen.
- Voordat u de aansluitingen maakt, moet u het contact uitzetten om kortsluiting te vermijden.
- Sluit de voedingskabel (2) aan op het apparaat en de luidsprekers voordat u deze aansluit op de hulpvoedingsaansluiting.
- Sluit alle aardingskabels op een gemeenschappelijk aardpunt aan.
- Voorzie niet aangesloten kabels om veilig

4

Foot brake type
Fußbremse
Type pédale de frein
Freno a pedale
Type voetrem



Parking brake switch cord
Parkbremsenschaltleitung
Cordon du capteur du frein à main
Cavo di commutazione del freno a mano
Schakelsnoer van de parkeerrem

Hand brake type
Handbremse
Type frein à main
Freno a mano
Type handrem

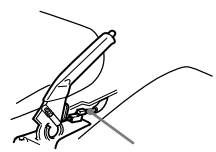

Parking brake switch cord
Parkbremsenschaltleitung
Cordon du capteur du frein à main
Cavo di commutazione del freno a mano
Schakelsnoer van de parkeerrem

5

1
Orient the release key correctly.
Richten Sie den Löseschlüssel korrekt aus.
Orientez correctement la clé de déblocage.
Orientare la chiavetta di rilascio nel modo corretto.
Plaats de ontgrendelingsleutel op de juiste manier.

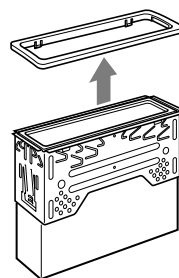
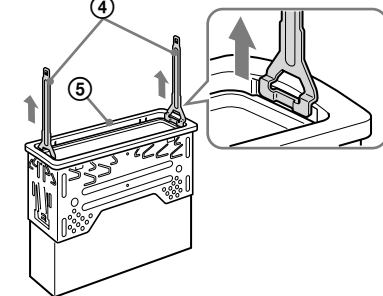

2

2
Face the hook inwards.
Der Haken muss nach innen weisen.
Tournez le crochet vers l'intérieur.
Con il gancetto rivolto verso l'interno.
Het haakje moet naar binnen wijzen.

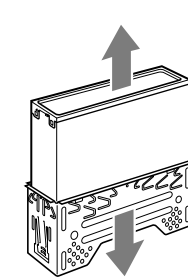
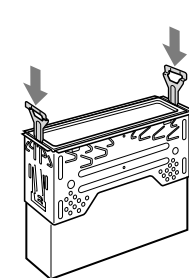
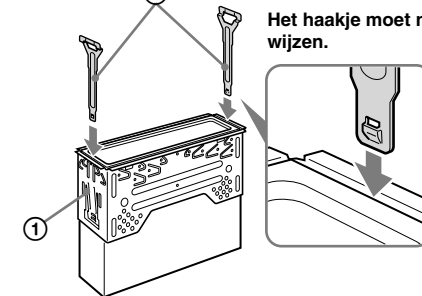

6

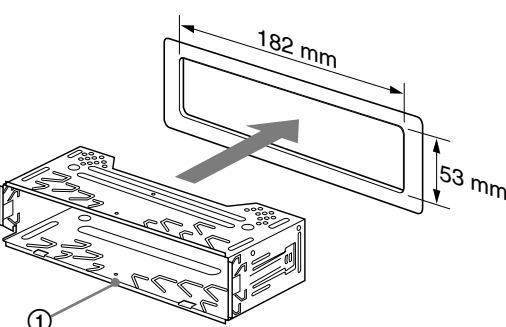

2

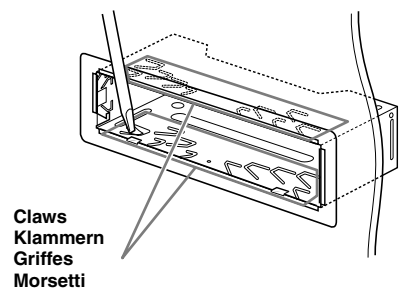

Claws
Klammern
Griffes
Morsetti
Klemhaken

3

Dashboard
Armaturenbrett
Tableau de bord
Cruscotto
Dashboard

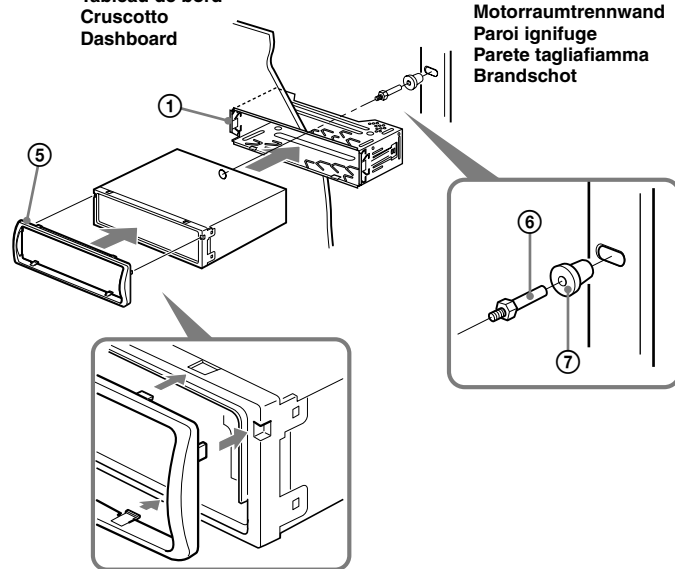

Fire wall
Motorraumtrennwand
Paroi ignifuge
Parete tagliafiamma
Brandschot

7

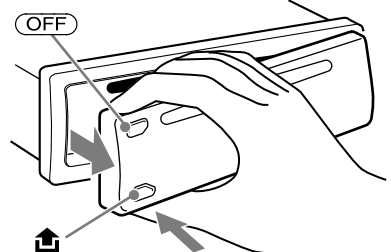

B

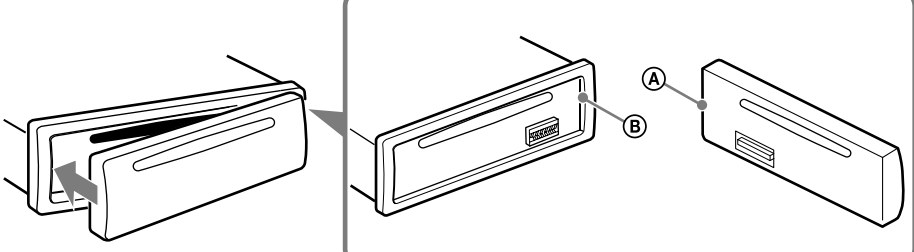

8

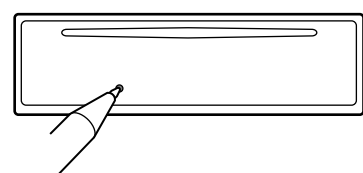

Precautions

- Choose the installation location carefully so that the unit will not interfere with normal driving operations.
- Avoid installing the unit in areas subject to dust, dirt, excessive vibration, or high temperature, such as in direct sunlight or near heater ducts.
- Use only the supplied mounting hardware for a safe and secure installation.

Mounting angle adjustment

Adjust the mounting angle to less than 45°.

Connecting the parking brake cord

Be sure to connect the parking cord (Light green) to the parking brake switch cord depends on your car. Consult your car dealer or your nearest Sony dealer for further details.

Removing the protection collar and the bracket

Before installing the unit, remove the protection collar and the bracket from the unit.

- Remove the protection collar.
 - Engage the release keys together with the protection collar.
 - Pull out the release keys to remove the protection collar.
- Remove the bracket.
 - Insert both release keys together between the unit and the bracket until they click.
 - Pull down the bracket, then pull up the unit to separate.

Mounting example

Installation in the dashboard

- Notes**
- Bend these claws outward for a tight fit, if necessary.
 - Make sure that the 4 catches on the protection collar are properly engaged in the slots of the unit.

How to detach and attach the front panel

Before installing the unit, detach the front panel.

7-A To detach

Before detaching the front panel, be sure to press OFF. Press and pull it off towards you.

7-B To attach

Engage part of the front panel with part of the unit, as illustrated, and push the left side into position until it clicks.

Warning if your car's ignition has no ACC position

Be sure to set the Auto Off function. For details, see the supplied Operating Instructions. The unit will shut off completely and automatically in the set time after the unit is turned off, which prevents battery drain. If you do not set the Auto Off function, press and hold until the display disappears each time you turn the ignition off.

RESET button

When the installation and connections are completed, be sure to press the RESET button with a ball-point pen, etc., after detaching the front panel.

Sicherheitshinweise

- Wählen Sie den Einbaort sorgfältig so aus, dass das Gerät beim Fahren nicht hinderlich ist.
- Bauen Sie das Gerät so ein, dass es keinen hohen Temperaturen (keinem direkten Sonnenlicht, keiner Warmluft von der Heizung), keinem Staub, keinem Schmutz und keinen starken Vibrationen ausgesetzt ist.
- Für eine sichere Befestigung verwenden Sie stets die mitgelieferten Montageteile.

Hinweis zum Montagewinkel

Das Gerät sollte in einem Winkel von weniger als 45° montiert werden.

Anschließen der Parkbremsenleitung

Die Parkleitung (hellgrün) muss unbedingt an die Parkbremsenschaltleitung angeschlossen werden. Die Montageposition der Parkbremsenschaltleitung ist von Fahrzeugmodell zu Fahrzeugmodell unterschiedlich. Weitere Informationen erhalten Sie bei Ihrem Fahrzeughändler oder Ihrem Sony-Händler.

Abnehmen der Schutzumrandung und der Halterung

Nehmen Sie vor dem Installieren des Geräts die Schutzumrandung und die Halterung vom Gerät ab.

- Entfernen Sie die Schutzumrandung.
 - Setzen Sie beide Löseschlüssel an der Schutzumrandung an.
 - Ziehen Sie die Schutzumrandung mithilfe der Löseschlüssel heraus.
- Entfernen Sie die Halterung.
 - Führen Sie beide Löseschlüssel zwischen dem Gerät und der Halterung ein, bis sie mit einem Klicken einrasten.
 - Ziehen Sie die Halterung nach unten und das Gerät nach oben, um die beiden zu trennen.

Montagebeispiel

Installation im Armaturenbrett

- Hinweise**
- Falls erforderlich, biegen Sie diese Klammern für einen sicheren Halt nach außen.
 - Achten Sie darauf, die 4 Verriegelungen an der Schutzumrandung korrekt in die Aussparungen am Gerät einzusetzen.

Abnehmen und Anbringen der Frontplatte

Nehmen Sie die Frontplatte vor dem Einbau des Geräts ab.

7-A Abnehmen

Schalten Sie das Gerät vor dem Abnehmen der Frontplatte unbedingt mit OFF aus. Drücken Sie und ziehen Sie sie auf sich zu heraus.

7-B Anbringen

Setzen Sie Teil der Frontplatte wie in der Abbildung dargestellt an Teil des Geräts an und drücken Sie die linke Seite der Frontplatte an, bis sie mit einem Klicken einrastet.

Warnhinweis, wenn die Zündung Ihres Fahrzeugs nicht über eine Zubehörsposition (ACC oder I) verfügt

Aktivieren Sie unbedingt die Abschaltautomatik. Näheres dazu finden Sie in der mitgelieferten Bedienungsanleitung. Nach dem Ausschalten wird das Gerät dann nach der voreingestellten Zeit automatisch vollständig abgeschaltet, so dass der Autobatterie kein Strom mehr entzogen wird. Wenn Sie die Abschaltautomatik nicht aktivieren, müssen Sie jedes Mal, wenn Sie die Zündung ausschalten, die Taste gedrückt halten, bis die Anzeige ausgeblendet wird.

Taste RESET

Wenn Sie das Gerät eingebaut und alle Anschlüsse vorgenommen haben, müssen Sie die Frontplatte abnehmen und mit einem Kugelschreiber oder einem anderen spitzen Gegenstand die Taste RESET drücken.

Précautions

- Choisir soigneusement l'emplacement de l'installation afin que l'appareil ne gêne pas la conduite normale du véhicule.
- Éviter d'installer l'appareil dans un endroit exposé à de la poussière, de la saleté, des vibrations violentes ou à des températures élevées, comme en plein soleil ou à proximité d'un conduit de chauffage.
- Pour garantir un montage sûr, n'utiliser que le matériel fourni.

Réglage de l'angle de montage

Ajuster l'inclinaison à un angle inférieur à 45°.

Raccordement du cordon du frein à main

Veillez à raccorder le cordon du frein (vert clair) au cordon du capteur du frein à main. La position de montage du cordon du capteur du frein à main varie selon la voiture. Consultez votre concessionnaire automobile ou votre revendeur Sony le plus proche pour obtenir plus de détails.

Retrait du tour de protection et du support

Avant d'installer l'appareil, retirez le tour de protection et le support de l'appareil.

- Retirez le tour de protection.
 - Enclenchez les clés de déblocage simultanément dans le tour de protection.
 - Tirez sur la clé de déblocage pour retirer le tour de protection.
- Retirez le support.
 - Insérez les deux clés de déblocage simultanément entre l'appareil et le support jusqu'au dé clic indiquant qu'elles sont en place.
 - Tirez le support vers le bas, puis tirez l'appareil vers le haut pour les séparer.

Exemple de montage

Installation dans le tableau de bord

- Remarques**
- Pliez ces griffes vers l'extérieur pour assurer une prise correcte si nécessaire.
 - Assurez-vous que les 4 loquets du tour de protection sont correctement insérés dans les fentes de l'appareil.

Retrait et fixation de la façade

Avant d'installer l'appareil, déposez la façade.

7-A Pour la retirer

Avant de retirer la façade, n'oubliez pas d'appuyer sur OFF. Appuyez ensuite sur et faites glisser la façade vers vous.

7-B Pour la mettre en place

Fixez la partie de la façade sur la partie de l'appareil, comme indiqué sur l'illustration, puis appuyez sur le côté gauche jusqu'au clic.

Avertissement au cas où le contact de votre voiture ne dispose pas d'une position ACC

Veillez à régler la fonction de mise hors tension automatique. Pour obtenir davantage d'informations, reportez-vous au mode d'emploi fourni. L'appareil s'éteint complètement et automatiquement après le laps de temps choisi une fois l'appareil mis hors tension afin d'éviter que la batterie ne se décharge. Si vous ne réglez pas la fonction de mise hors tension automatique, appuyez sur la touche OFF et maintenez-la enfoncée jusqu'à ce que l'affichage disparaisse à chaque fois que vous coupez le contact.

Touche RESET

Une fois que l'installation et les raccordements sont terminés, retirez la façade et appuyez sur le bouton RESET à l'aide d'un stylo à bille ou d'un autre objet pointu.

Tasto RESET

Una volta completate le procedure di installazione e i collegamenti, accertarsi di premere il tasto RESET con una penna a sfera o un oggetto simile dopo avere rimosso il pannello anteriore.

Precauzioni

- Scegliere con attenzione la posizione per l'installazione in modo che l'apparecchio non interferisca con le operazioni di guida del conducente.
- Evitare di installare l'apparecchio dove sia soggetto ad alte temperature, come alla luce solare diretta o al getto di aria calda dell'impianto di riscaldamento, o dove possa essere soggetto a polvere, sporcizia e vibrazioni eccessive.
- Usare solo il materiale di montaggio in dotazione per un'installazione stabile e sicura.

Regolazione dell'angolo di montaggio

Regolare l'angolo di montaggio in modo che sia inferiore a 45°.

Collegamento del cavo del freno a mano

Assicurarsi di collegare il cavo del freno a mano (verde chiaro) al cavo di commutazione del freno a mano dell'auto. La posizione di montaggio del cavo di commutazione del freno a mano varia in base all'auto. Per ulteriori informazioni, consultare l'autoconcessionaria di fiducia o il più vicino rivenditore Sony.

Rimozione della staffa e della cornice protettiva

Prima di installare l'apparecchio, rimuovere la cornice protettiva e la staffa dell'apparecchio.

- Rimuovere la cornice protettiva.
 - Inserire le chiavette di rilascio nella cornice protettiva.
 - Per rimuovere la cornice protettiva estrarre le chiavette di rilascio.
- Rimuovere la staffa.
 - Inserire contemporaneamente entrambe le chiavette di rilascio tra l'apparecchio e la staffa fino a che non scattano in posizione.
 - Estrarre la staffa, quindi sollevare l'apparecchio per rimuoverlo.

Esempio di montaggio

Installazione nel cruscotto

- Note**
- Piegare verso l'esterno questi morsetti per un'installazione più sicura, se necessario.
 - Assicurarsi che i fermi sulla cornice protettiva siano correttamente inseriti negli alloggiamenti dell'apparecchio.

Rimozione e applicazione del pannello anteriore

Prima di installare l'apparecchio rimuovere il pannello anteriore.

7-A Per rimuoverlo

Prima di rimuovere il pannello anteriore, premere OFF. Premere e tirare verso di sé il pannello anteriore.

7-B Per applicarlo

Applicare la parte del pannello anteriore alla parte dell'apparecchio come mostrato nell'illustrazione e premere il lato sinistro fino a sentire uno scatto.

Avvertenza relativa all'installazione su un'auto sprovvista della posizione ACC (accessoria) sul blocchetto di accensione

Accertarsi di impostare la funzione di spegnimento automatico. Per ulteriori informazioni, fare riferimento alle istruzioni per l'uso in dotazione. L'apparecchio si spegne completamente e automaticamente all'ora impostata dopo che è stato disattivato, onde evitare che la batteria si scarichi. Se la funzione di spegnimento automatico non è stata impostata, ogni volta che il motore viene spento tenete premuto OFF finché il display non viene disattivato.

Tasto RESET

Una volta completate le procedure di installazione e i collegamenti, accertarsi di premere il tasto RESET con una penna a sfera o un oggetto simile dopo avere rimosso il pannello anteriore.

Voorzorgsmaatregelen

- Kies de installatieplaats zorgvuldig zodat het apparaat de bestuurder niet hindert tijdens het rijden.
- Installeer het apparaat niet op plaatsen waar het blootgesteld wordt aan hoge temperaturen, b.v. in direct zonlicht of bij de warme luchtstrom van de autoverwarming, aan sterke trillingen, of waar het in contact komt met veel stof of vuil.
- Gebruik voor het veilig en stevig monteren van het apparaat uitsluitend de bijgeleverde montage-onderdelen.

Maximale montagehoek

Installeer het apparaat nooit onder een hoek van meer dan 45° met het horizontale vlak.

Parkeerremkabel aansluiten

Sluit de parkeerremkabel (lichtgroen) van de parkeerrem aan op het schakelsnoer van de parkeerrem. De plaats waar het schakelsnoer van de parkeerrem moet worden geplaatst, is afhankelijk van de auto. Raadpleeg de autohandeloor of de dichtstbijzijnde Sony-handelaar voor meer informatie.

De beschermende rand en de beugel verwijderen

Voordat u het apparaat gaat installeren, moet u de beschermende rand en de beugel verwijderen van het apparaat.

- Verwijder de beschermende rand.
 - Bevestig de ontgrendelingsleutels op de beschermende rand.
 - Trek de ontgrendelingsleutels naar u toe om de beschermende rand te verwijderen.
- Verwijder de beugel.
 - Plaats de ontgrendelingsleutels tussen het apparaat en de beugel tot deze vastklikken.
 - Trek de beugel omhoog en trek het apparaat omhoog om deze van elkaar te scheiden.

Montagevoorbeeld

Montage in het dashboard

- Opmerkingen**
- Indien nodig kunt u deze klemhaken ombuigen voor een stevigere bevestiging.
 - De 4 grepen op de beschermende rand moeten goed in de sloten van het apparaat zijn geplaatst.

Het voorpaneel verwijderen en bevestigen

Verwijder, alvorens met het installeren te beginnen, het voorpaneel.

7-A Verwijderen

Vergeet niet, voordat u het voorpaneel verwijdert, eerst op OFF te drukken. Druk vervolgens op de toets en trek het naar u toe.

7-B Bevestigen

Breng deel van het voorpaneel aan op deel van het apparaat zoals afgebeeld en druk op de linkerzijde tot deze vastklikt.

Waarschuwing als het contactslot van de auto geen ACC-positie heeft

Zorg ervoor dat u de functie voor automatisch uitschakelen instelt. Raadpleeg de bijgeleverde gebruiksaanwijzing voor meer informatie. Het apparaat wordt na de ingestelde tijd automatisch volledig uitgeschakeld nadat het apparaat is uitgeschakeld. Zo wordt voorkomen dat de accu leegloopt. Als u de functie voor automatisch uitschakelen niet instelt, moet u OFF ingedrukt houden tot het display verdwijnt telkens wanneer u het contact uitschakelt.

RESET-toets

Als u de installatie en aansluitingen hebt voltooid, moet u met een puntig voorwerp, zoals de punt van een balpen, op RESET drukken nadat u het voorpaneel hebt verwijderd.

Power connection diagram

Auxiliary power connector may vary depending on the car. Check your car's auxiliary power connector diagram to make sure the connections match correctly. There are three basic types (illustrated below). You may need to switch the positions of the red and yellow leads in the car stereo's power supply lead. After matching the connections and switched power supply leads correctly, connect the unit to the car's power supply. If you have any questions and problems connecting your unit that are not covered in this manual, please consult the car dealer.

Diagramma dei collegamenti di alimentazione

Il connettore di alimentazione ausiliaria può variare a seconda della macchina. Controllare il diagramma del connettore di alimentazione ausiliaria della macchina per essere sicuri che i collegamenti corrispondano correttamente. Vi sono tre tipi di base (illustrazione sotto). Potrà essere necessario cambiare le posizioni dei fili rosso e giallo nel cavo di alimentazione dello stereo della macchina.

Dopo aver fatto corrispondere i collegamenti e aver commutato i cavi di alimentazione, collegare l'apparecchio all'alimentazione della macchina. Se si hanno domande o se sorgono problemi che non sono stati trattati nel manuale nel collegare l'apparecchio, contattare l'autoconcessionario.

Stromanschlussdiagramm

Der Hilfsstromanschluss kann je nach Fahrzeugtyp unterschiedlich sein. Sehen Sie im Hilfsstromanschlussdiagramm für Ihr Fahrzeug nach, wie die Verbindung ordnungsgemäß vorgenommen werden muss. Es gibt, wie unten abgebildet, drei grundlegende Typen. Sie müssen möglicherweise die rote und gelbe Leitung des Stromversorgungskabels der Autostereoanlage vertauschen. Stellen Sie die Anschlüsse her, schließen Sie die geschalteten Stromversorgungsleitungen richtig an und verbinden Sie dann das Gerät mit der Stromversorgung Ihres Fahrzeugs. Wenn beim Anschließen des Geräts Fragen oder Probleme auftreten, die in dieser Bedienungsanleitung nicht erläutert werden, wenden Sie sich bitte an den Autohändler.

Voedingsaansluitschema

De hulpvoedingsaansluiting kan verschillen afhankelijk van de auto. Controleer het voedingsaansluitschema dat bij dit apparaat wordt geleverd om te zien of de aansluitingen kloppen. Er zijn drie basistypes (zie afbeelding hieronder). Het is mogelijk dat u de posities van de rode en gele kabels in de voedingskabel van het car audiosysteem moet omwisselen. Als de aansluitingen en geschakelde voedingskabels kloppen, sluit u het apparaat aan op de voeding van de auto. Indien u nog vragen of problemen hebt in verband met het aansluiten van het apparaat die niet in deze handleiding vermeld staan, raadpleeg dan de auto dealer.

Schéma de raccordement d'alimentation

Le connecteur d'alimentation auxiliaire peut varier suivant le type de voiture. Vérifiez le schéma du connecteur d'alimentation auxiliaire de votre voiture pour vous assurer que les connexions correspondent. Il se peut que vous deviez commuter la position des fils rouge et jaune du cordon d'alimentation de l'autoradio. Après avoir établi les connexions et commuté correctement les fils d'alimentation, raccordez l'appareil à l'alimentation de la voiture. Si vous avez des questions ou des difficultés à propos de cet appareil qui ne sont pas abordés dans le présent mode d'emploi, consultez votre concessionnaire automobile.

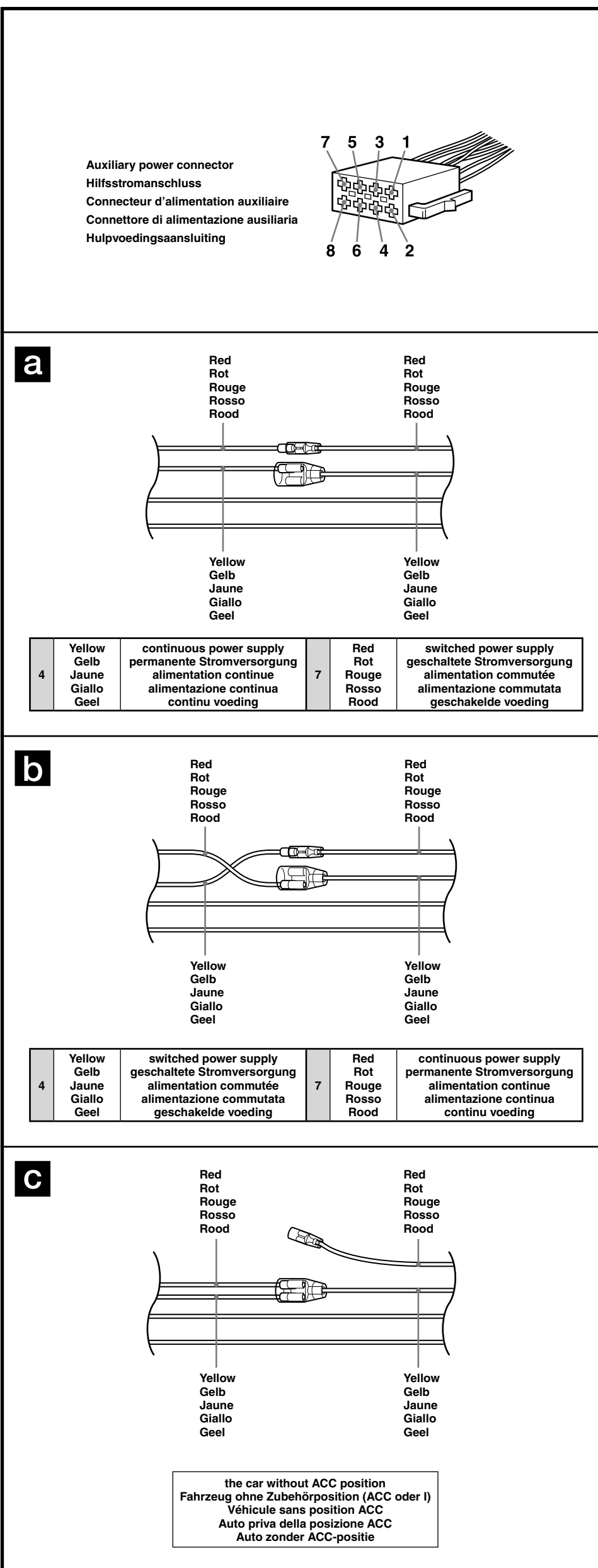

Free Manuals Download Website

<http://myh66.com>

<http://usermanuals.us>

<http://www.somanuals.com>

<http://www.4manuals.cc>

<http://www.manual-lib.com>

<http://www.404manual.com>

<http://www.luxmanual.com>

<http://aubethermostatmanual.com>

Golf course search by state

<http://golfingnear.com>

Email search by domain

<http://emailbydomain.com>

Auto manuals search

<http://auto.somanuals.com>

TV manuals search

<http://tv.somanuals.com>