

# SONY®



CAMERA ADAPTOR

# CA-590/590P

The supplied CD-ROM includes operation manuals for the CA-590/590P, CCU-590/590P, and CCU-790/790P (English, Japanese, French, German, Italian, and Spanish versions) in PDF format. For more details, see “*Using the CD-ROM Manual*” on page 5.

OPERATION MANUAL English  
1st Edition (Revised 1)

## WARNING

**To reduce the risk of fire or electric shock, do not expose this apparatus to rain or moisture.**

**To avoid electrical shock, do not open the cabinet. Refer servicing to qualified personnel only.**

## AVERTISSEMENT

**Afin de réduire les risques d'incendie ou d'électrocution, ne pas exposer cet appareil à la pluie ou à l'humidité.**

**Afin d'écartier tout risque d'électrocution, garder le coffret fermé. Ne confier l'entretien de l'appareil qu'à un personnel qualifié.**

## WARNUNG

**Um die Gefahr von Bränden oder elektrischen Schlägen zu verringern, darf dieses Gerät nicht Regen oder Feuchtigkeit ausgesetzt werden.**

**Um einen elektrischen Schlag zu vermeiden, darf das Gehäuse nicht geöffnet werden. Überlassen Sie Wartungsarbeiten stets nur qualifiziertem Fachpersonal.**

### For the State of California, USA only

Perchlorate Material - special handling may apply, See [www.dtsc.ca.gov/hazardouswaste/perchlorate](http://www.dtsc.ca.gov/hazardouswaste/perchlorate)  
Perchlorate Material : Lithium battery contains perchlorate.

### For the customers in the U.S.A. (for CA-590)

This equipment has been tested and found to comply with the limits for a Class A digital device, pursuant to Part 15 of the FCC Rules. These limits are designed to provide reasonable protection against harmful interference when the equipment is operated in a commercial environment. This equipment generates, uses, and can radiate radio frequency energy and, if not installed and used in accordance with the instruction manual, may cause harmful interference to radio communications. Operation of this equipment in a residential area is likely to cause harmful interference in which case the user will be required to correct the interference at his own expense.

You are cautioned that any changes or modifications not expressly approved in this manual could void your authority to operate this equipment.

All interface cables used to connect peripherals must be shielded in order to comply with the limits for a digital device pursuant to Subpart B of Part 15 of FCC Rules.

### For the customers in Europe (for CA-590P)

This product with the CE marking complies with both the EMC Directive and the Low Voltage Directive issued by the Commission of the European Community.

Compliance with these directives implies conformity to the following European standards:

- EN60950-1 : Product Safety
- EN55103-1 : Electromagnetic Interference(Emission)
- EN55103-2 : Electromagnetic Susceptibility(Immunity)

This product is intended for use in the following Electromagnetic Environments:

E1 (residential), E2 (commercial and light industrial), E3 (urban outdoors), E4 (controlled EMC environment, ex. TV studio)

### Pour les clients européens (pour CA-590P)

Ce produit portant la marque CE est conforme à la fois à la Directive sur la compatibilité électromagnétique (EMC) et à la Directive sur les basses tensions émises par la Commission de la Communauté Européenne.

La conformité à ces directives implique la conformité aux normes européennes suivantes :

- EN60950-1 : Sécurité des produits
- EN55103-1 : Interférences électromagnétiques (émission)
- EN55103-2 : Sensibilité électromagnétique (immunité)

Ce produit est prévu pour être utilisé dans les environnements électromagnétiques suivants :

E1 (résidentiel), E2 (commercial et industrie légère), E3 (urbain extérieur) et E4 (environnement EMC contrôlé, ex. studio de télévision).

### Für Kunden in Europa (für CA-590P)

Dieses Produkt besitzt die CE-Kennzeichnung und erfüllt die EMV-Richtlinie sowie die Niederspannungsrichtlinie der EG-Kommission.

Angewandte Normen:

- EN60950-1: Sicherheitsbestimmungen
- EN55103-1: Elektromagnetische Verträglichkeit (Störaussendung)
- EN55103-2: Elektromagnetische Verträglichkeit (Störfestigkeit), für die folgenden elektromagnetischen Umgebungen: E1 (Wohnbereich), E2 (kommerzieller und in beschränktem Maße industrieller Bereich), E3 (Stadtbereich im Freien) und E4 (kontrollierter EMV-Bereich, z.B. Fernsehstudio).

### For the customers in Europe (for CA-590P)

The manufacturer of this product is Sony Corporation, 1-7-1 Konan, Minato-ku, Tokyo, Japan.

The Authorized Representative for EMC and product safety is Sony Deutschland GmbH, Hedelfinger Strasse 61, 70327 Stuttgart, Germany. For any service or guarantee matters please refer to the addresses given in separate service or guarantee documents.

**Pour les clients européens (pour CA-590P)**

Le fabricant de ce produit est Sony Corporation, 1-7-1 Konan, Minato-ku, Tokyo, Japon.

Le représentant autorisé pour EMC et la sécurité des produits est Sony Deutschland GmbH, Hedelfinger Strasse 61, 70327 Stuttgart, Allemagne. Pour toute question concernant le service ou la garantie, veuillez consulter les adresses indiquées dans les documents de service ou de garantie séparés.

**Für Kunden in Europa (für CA-590P)**

Der Hersteller dieses Produkts ist Sony Corporation, 1-7-1 Konan, Minato-ku, Tokyo, Japan.

Der autorisierte Repräsentant für EMV und Produktsicherheit ist Sony Deutschland GmbH, Hedelfinger Strasse 61, 70327 Stuttgart, Deutschland. Bei jeglichen Angelegenheiten in Bezug auf Kundendienst oder Garantie wenden Sie sich bitte an die in den separaten Kundendienst- oder Garantiedokumenten aufgeführten Anschriften.

---

# Table of Contents

<b>Overview .....</b>	<b>5</b>
<b>Using the CD-ROM Manual .....</b>	<b>5</b>
Preparations .....	5
Reading the CD-ROM manual .....	5
<b>Function and Location of Parts and Controls .....</b>	<b>6</b>
<b>Internal Boards and Switch Settings .....</b>	<b>9</b>
❶ TR-132 board .....	10
❷ MA-128 board .....	10
❸ AU-294 board .....	11
❹ DM-139 board .....	12
❺ MB-1019 board .....	12
<b>Preparations .....</b>	<b>14</b>
Attaching the CA-590/590P to a BVP-E10/E10P/E10WS/ E10WSP/E30/E30P/E30WS/E30WSP Color Video Camera .....	14
Securing the triax cable to the camera adaptor .....	15
<b>Connections .....</b>	<b>17</b>
Connectable equipment .....	17
Power supply .....	17
<b>Self-Diagnostics .....</b>	<b>18</b>
Displaying the DIAGNOSIS menu .....	18
The contents of the self-diagnostics results .....	18
<b>Specifications .....</b>	<b>19</b>
General .....	19
Input/output connectors .....	19
Supplied accessories .....	19
Optional accessories .....	19

---

## Overview

The CA-590/590P Camera Adaptor attaches to the BVP-E10/E10P/E10WS/E10WSP/E30/E30P/E30WS/E30WSP Color Video Camera to allow the connection of a CCU-550D/550DP/590/590P/700A/700AP/790/790P Camera Control Unit through a triax cable.

The CA-590/590P has the following features:

### Component signal transmission system

The CA-590/590P transmits a component signal (Y/R–Y/B–Y) through a triax cable.

### Low power consumption

An AC/DC converter of higher efficiency than the previous model has reduced power consumption to about 8 W (within the CA-590/590P).

### Anti-electrical shock function

The high-voltage supply from the CCU (camera control unit) is cut when the triax cable is not completely connected.

### Variety of input/output connectors

The CA-590/590P is equipped with the following connectors:

- DC power input/output connector
- Input connector for remote-switching of return video 1, 2, 3, and 4
- Prompter signal/external sync signal input connector
- RCP connector
- INCOM connector (2)
- AUDIO (LINE/MIC switch available) input connector (2)
- PROMPTER/RETURN video output connector
- EARPHONE jack
- TRACKER connector

#### Note

Production of some of the peripherals and related devices described in this manual has been discontinued. For advice about choosing devices, please contact your Sony dealer or a Sony sales representative.

---

## Using the CD-ROM Manual

The supplied CD-ROM includes versions of the Operation Manuals for the CA-590/590P, CCU-590/590P, and CCU-790/790P<sup>1)</sup> in PDF format.

1) Available languages: Japanese (CA-590 and CCU-590 only), English, French, German, Italian, and Spanish

---

## Preparations

The following program must be installed on your computer in order to read the operation manuals contained on the CD-ROM.

- Adobe Reader Version 6.0 or higher

If Adobe Reader is not installed, you can download it from the following URL:

<http://www.adobe.com/>

Adobe and Adobe Reader are trademarks of Adobe Systems Incorporated in the United States and/or other countries.

---

## Reading the CD-ROM manual

To read the operation manual contained on the CD-ROM, do the following.

- 1 Insert the CD-ROM in your CD-ROM drive.

A cover page appears automatically in your browser. If it does not appear automatically in the browser, double-click on the `index.htm` file on the CD-ROM.

- 2 Select and click on the operation manual that you want to read.

This opens the PDF file of the operation manual.

#### Memo

The files may not be displayed properly, depending on the version of Adobe Reader.

In such a case, install the latest version you can download from the URL mentioned in “Preparations” above.

#### Note

If you have lost or damaged the CD-ROM, you can purchase a new one to replace it. Contact your Sony service representative.

# Function and Location of Parts and Controls

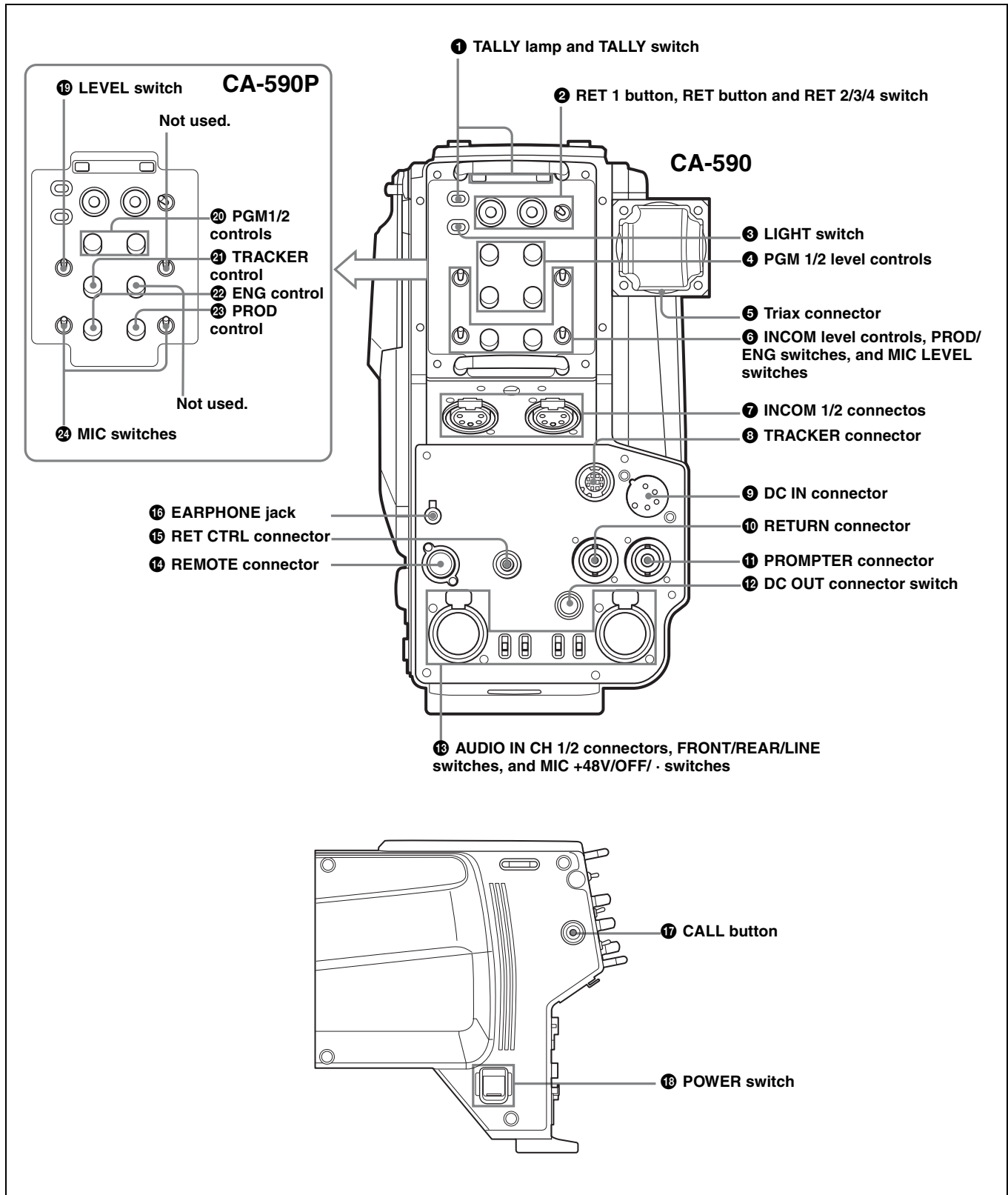

### ❶ TALLY lamp and TALLY switch

When the TALLY switch is ON, the TALLY lamp lights when a red tally signal, green tally signal, or call signal is input from the CCU.

Turning the S101 switch on the internal AU-294 board to ON mixes and outputs the battery alarm signal to the TALLY lamp.

### ❷ RET 1 button, RET button and RET 2/3/4 switch

#### RET1 (return video 1) button

While this button is pressed down, the return video 1 signal from the CCU (camera control unit) can be monitored in the viewfinder or on a monitor connected to the RETURN connector.

#### RET (return video) button

While this button is pressed down, the return video signal from the CCU can be monitored in the viewfinder. Select the monitored signal with the RET 2/3/4 switch.

#### RET 2/3/4 switch

Selects the return video signal to be monitored in the viewfinder while the RET button is pressed down.

### ❸ LIGHT switch

Turns the backlight on the upper part of the panel and the light on the connector section on or off. Depending on the switch position, both lights turn on, only the light on the connector section turns on, or both lights turn off.

### ❹ PGM (program audio) 1/2 level controls (for the CA-590)

These controls adjust the audio volume of the program. PGM level controls are provided for both intercom 1 and 2.

### ❺ Triax connector

Connects a CCU-550D/550DP/590/590P/700A/700AP/790/790P Camera Control Unit through a triax cable.

### ❻ INCOM level controls, PROD/ENG switches, and MIC LEVEL switches (for the CA-590)

#### INCOM (intercom) level controls

These controls adjust the audio reception level of the intercom 1/2.

#### PROD/ENG (producer/engineer) switches

Select the line for the microphone of the intercoms connected to the respective INCOM connectors.

**PROD:** Selects the producer's line.

**ENG:** Selects the engineer's line.

#### MIC/LEVEL (microphone/intercom level) switches

The MIC and LEVEL settings specify the following functions:

**ON/REAR:** Turns on the intercom microphone. Adjust the intercom reception level with the INCOM level control.

**OFF/REAR:** Turns off the intercom microphone. Turn the intercom microphone on and off using the control on the external equipment connected to the RET CTRL connector. Adjust the intercom reception level with the INCOM level control.

**OFF/FRONT:** Turns off the intercom microphone. Turn the intercom microphone on and off using the control on the external equipment connected to the RET CTRL connector or the VTR S/S switch on the video camera. Use the control on the video camera to adjust the intercom reception level. Depending on the video camera, intercom reception level adjustment requires menu operation.

### ❽ INCOM (intercom) 1/2 connectos

Connect headsets to enable the reception of program/intercom audio and transmission of intercom audio. Set the S3 switch on the internal MA-128 board to "CM" when using headsets with a carbon-type microphone, and set it to "DYN" when using headsets with a dynamic-type microphone.

The INCOM 1 connector can be used for communications through the engineer's line even though the power to the camera is turned off on the CCU-550D/550DP/590/590P/700A/700AP/790/790P.

### ❾ TRACKER connector (10-pin)

Used for communications with a tracker and intercom 1 and 2 communications. Also outputs the up tally and program audio signals. The maximum current output from this connector is 500 mA. Settings regarding the input/output signals can be made on the internal AU-294 board.

### ❿ DC IN (direct current input) connector (4-pin)

Connects an AC adapter or battery case. Supplies power to the CA-590/590P when the POWER switch is set to EXT.

### ⓫ RETURN (return video output) connector (BNC type)

Outputs the return video signal.

### ⓬ PROMPTER (prompter video signal input/output) connector (BNC type)

Inputs and outputs a prompter video signal. Use the S301 switch on the DM-139 internal board to select the transmission direction (input or output) of the prompter video signal. When the setting is made on the camera adaptor, the transmission direction must be also changed on the CCU.

### ⓭ DC OUT (direct current output) connector (4-pin)

Outputs a direct current of 10.5 V to 17 V at a maximum rated current output of 1.5 A. Connecting equipment with a power consumption greater than the maximum rating will activate the protection circuit, cutting off the current flow.

**13 AUDIO IN CH 1/2 connectors, FRONT/REAR/ LINE switches, and MIC +48V/OFF/• switches**

**AUDIO IN (audio input) CH 1/2 connectors (XLR type, 3-pin)**

These connectors input external audio signals.

**FRONT/REAR/LINE (audio signal selection) switches**

These switches make settings for the respective audio signals input from the AUDIO IN CH 1/2 connectors.

**FRONT:** Selects the audio input from the video camera as the audio signal.

**REAR:** Outputs the audio signal input from the AUDIO IN connector to the CCU. Gain control setting for the connected microphone must be made on the CCU.

**LINE:** Sets the level for the signal input from the AUDIO IN connector to -20 dB.

**MIC +48V/OFF/• (microphone power supply mode) switches**

The following power supply settings can be specified for the external microphone:

**MIC +48V:** +48 V is supplied to the external microphone through the AUDIO IN connector. Set to this position when the microphone requires +48 V of power supply.

**OFF:** No power is supplied through the AUDIO IN connector.

- : +12 V is supplied to the external microphone through the AUDIO IN connector. Set to this position when the microphone requires +12 V of power supply. This position becomes selectable when the S2 switch on the MA-128 internal board is set to ON (page 9).

**Note**

Supplying power whose voltage does not match the requirement to the microphone may damage the microphone. Be sure to set the MIC +48V/OFF/• switches to match the power requirement of the microphones.

**14 REMOTE connector (8-pin)**

Connects an RCP-750/751/920/921 Remote Control Panel or RM-B150 Remote Control Unit. Connection must be made with a cable of 150 feet (50 meters) or less in length.

**Notes**

- The REMOTE connector cannot be used when a CCU is connected.
- When connecting the RM-B150, use the cable supplied with the RM-B150.

**15 RET CTRL (return control) connector (6-pin)**

Inputs the control signal for selecting the return video and for turning the intercom microphone on and off.

**16 EARPHONE jack (mini-jack)**

Connects an earphone for monitoring the audio from the intercom or the program. Select the audio source with the S251 and S252 switches on the internal AU-294 board.

**17 CALL button**

Use this button to call the CCU or MSU (master setup unit) operator. When this button is pressed, the red tally lamps in the viewfinder and on the CCU or MSU light up.

**18 POWER switch**

Selects the power supply.

**CCU:** Power is supplied from the CCU.

**OFF:** Standby mode.

**EXT:** Power is supplied from the DC IN connector.

**19 LEVEL (intercom level) switch (for the CA-590P)**

Selects the reception level adjustment method for the intercoms connected to the INCOM 1/2 connectors.

**REAR:** Select this position to adjust the reception level of the intercoms using the PGM1/2 controls, TRACKER control, ENG control, and PROD control independently.

**FRONT:** When this position is selected, audio volume of the program, reception level of the intercom connected to the TRACKER connector, and the reception level of the engineer's line and the producer's line are adjusted at one operation using the control on the video camera.

**20 PGM1/2 controls (for the CA-590P)**

These controls adjust the audio volume of the program. PGM1 control adjusts the program audio input from the INCOM1 connector and the PGM2 control adjusts the program audio input from the INCOM2 connector.

**21 TRACKER control (for the CA-590P)**

Adjusts the reception level of the intercom connected to the TRACKER connector.

**22 ENG (engineer) control (for the CA-590P)**

Adjusts the reception level of the engineer's line.

**23 PROD (producer) control (for the CA-590P)**

Adjusts the reception level of the producer's line.

**24 MIC (microphone level) switches (for the CA-590P)**

Select the connection line of the intercom microphone independently for the intercoms connected to the INCOM 1/2 connectors.

**PROD:** Connects the intercom microphone to the producer's line.

**ENG:** Connects the intercom microphone to the engineer's line.

**OFF:** Cuts the intercom microphone connection.



# Internal Boards and Switch Settings

## Note

To reduce the risk of electric shock, fire or injury, do not open the cabinet. To adjust the internal settings, refer to qualified service personnel.

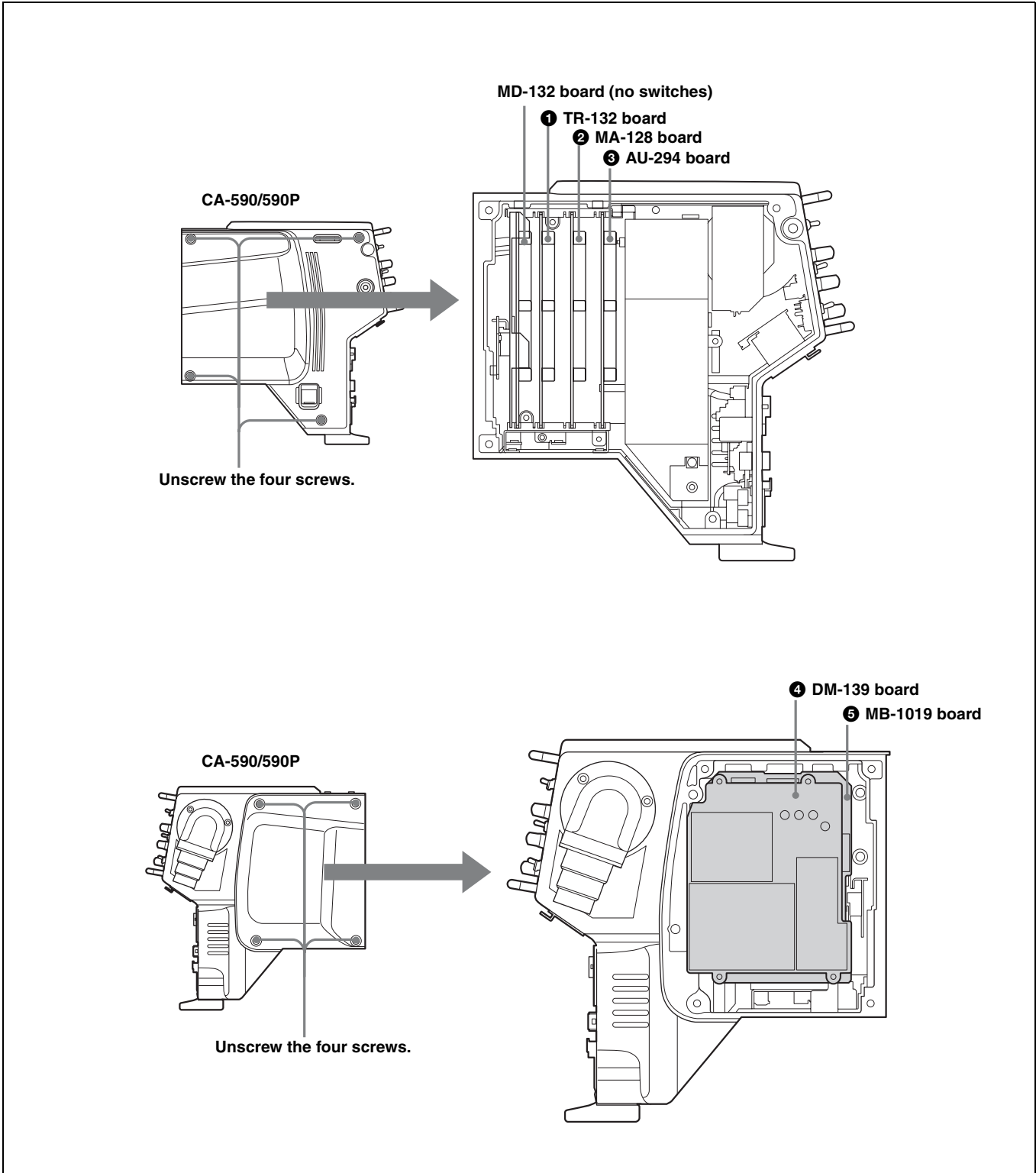

## ① TR-132 board

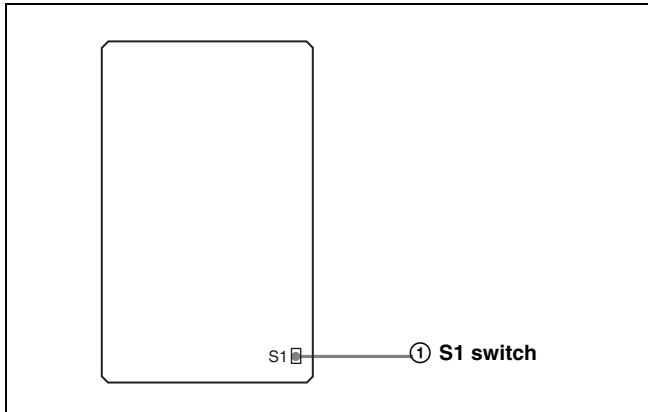

### ① S1 switch

Available in near future. Set this switch to OFF.

## ② MA-128 board

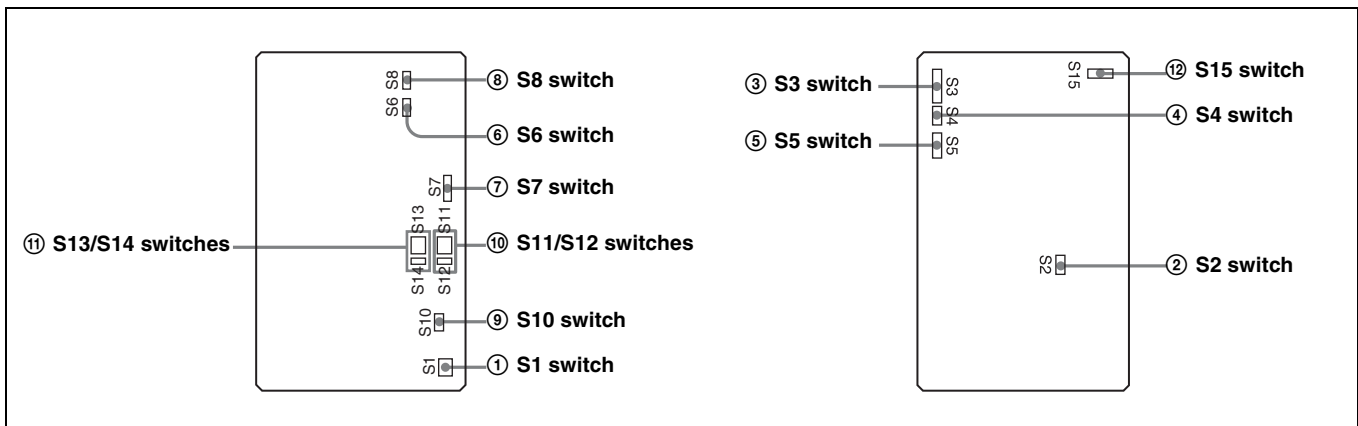

### ① S1 switch

Available in near future. Set this switch to OFF.

### ② S2 switch

Set to ON only when supplying AC power to the microphones connected to the AUDIO IN CH 1/2 connectors. Normally, set this switch to OFF.

### ③ S3 switch

Set according to the microphone type of the headset connected to the INCOM 1 connector.

**DYN:** Dynamic-type microphone

**CM:** Carbon-type microphone

### ④ S4 switch

Set to ON when an unbalanced-type headset is connected to the INCOM 1 connector.

### ⑤ S5 switch

Sets the gain for the headset connected to the INCOM 1 connector.

**+** : Sets the gain 6 dB above the standard level.

**0** : Standard level.

**-** : Sets the gain 6 dB below the standard level.  
Normally, set this switch to 0.

### ⑥ S6 switch

When set to ON, the audio signals input from the AUDIO IN CH 1/2 connectors are mixed to the intercom audio and output to the INCOM 1 connector. This switch is factory-set to OFF.

### ⑦ S7 switch

When set to ON, the audio signal input from the TRACKER connector is mixed to the intercom audio and output to the INCOM 1 connector. Normally, set this switch to OFF (center position).

### ⑧ S8 switch

Specifies whether the VR of the INCOM 1 is used for serial mix or parallel mix. Normally, set this switch to OFF.

### ⑨ S10 switch

This switch is used for the intercom system connected to the INCOM 1 connector. Normally, set this switch to NORM.

### ⑩ S11/S12 switches

These switches select the audio to be mixed with the audio output to the INCOM 1 connector.

Switch	Audio to be mixed	Normal setting
S11-1	Audio from INCOM 1	ON
S11-2	Audio from INCOM 2	OFF
S11-3	Program audio 1	OFF
S11-4	Program audio 2	OFF
S12	Tracker audio	ON

When a one ear headset is used, set the S11-3 and S11-4 switches to ON.

### ⑪ S13/S14 switches

These switches select the audio to be mixed with the program audio output to the INCOM 1 connector.

Switch	Audio to be mixed	Normal setting
S13-1	Audio from INCOM 1	OFF
S13-2	Audio from INCOM 2	OFF
S13-3	Program audio 1	ON
S13-4	Program audio 2	ON
S14	Tracker audio	OFF

When a one ear headset is used, set the S13-1 and S13-2 switches to ON.

### ⑫ S15 switch

Set according to the broadcast system.

**OFF:** NTSC (for the CA-590)

**ON:** PAL (for the CA-590P)

## ③ AU-294 board

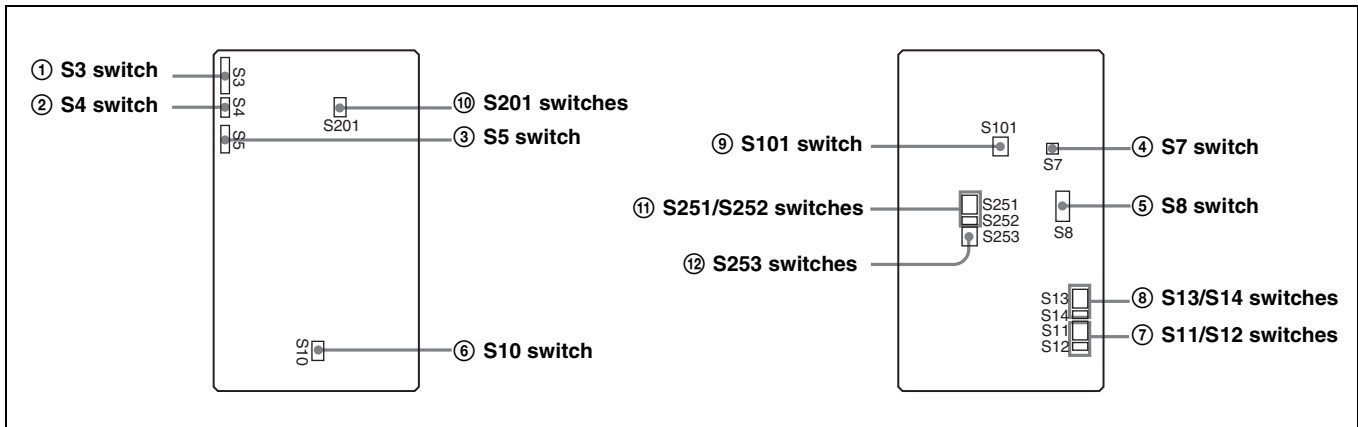

### ① S3 switch

Set according to the microphone type of the headset connected to the INCOM 2 connector.

**DYN:** Dynamic-type microphone

**CM:** Carbon-type microphone

### ② S4 switch

Set to ON when an unbalanced-type headset is connected to the INCOM 2 connector.

### ③ S5 switch

Sets the gain for the headset connected to the INCOM 2 connector.

**+** : Sets the gain 6 dB above the standard level.

**0** : Standard level.

**-** : Sets the gain 6 dB below the standard level.

Normally, set this switch to 0.

### ④ S7 switch

When set to ON, the audio signal input from the TRACKER connector is mixed to the intercom audio and

output to the INCOM 2 connector. Normally, set this switch to OFF (center position).

### ⑤ S8 switch

Specifies whether the VR of the INCOM 2 is used for serial mix or parallel mix. Normally, set this switch to OFF.

### ⑥ S10 switch

This switch is used for the intercom system connected to the INCOM 2 connector. Normally, set this switch to NORM.

### ⑦ S11/S12 switches

These switches select the audio to be mixed with the audio output to the INCOM 2 connector.

Switch	Audio to be mixed	Normal setting
S11-1	Audio from INCOM 1	OFF
S11-2	Audio from INCOM 2	ON
S11-3	Program audio 1	OFF

Switch	Audio to be mixed	Normal setting
S11-4	Program audio 2	OFF
S12	Tracker audio	OFF

When a one ear headset is used, set the S11-3 and S11-4 switches to ON.

### ⑧ S13/S14 switches

These switches select the audio to be mixed with the program audio output to the INCOM 2 connector.

Switch	Audio to be mixed	Normal setting
S13-1	Audio from INCOM 1	OFF
S13-2	Audio from INCOM 2	OFF
S13-3	Program audio 1	ON
S13-4	Program audio 2	ON
S14	Tracker audio	OFF

When a one ear headset is used, set the S13-1 and S13-2 switches to ON.

### ⑨ S101 switch

Selects the item to be mixed with the battery alarm signal.

Switch	Item to be mixed	Normal setting
S101-1	Battery alarm signal	ON
S101-2	TEMP	OFF
S101-3	FAN STOP	OFF

### ⑩ S201 switches

Sets the talk level through the TRACKER connector.

– 20: Decreases the level by 20 dB.

0: Standard level.

Normally, set this switch to 0.

### ⑪ S251/S252 switches

These switches select the audio to be output to the EARPHONE jack.

Switch	Audio to be output
S251-1	Audio from INCOM 1
S251-2	Audio from INCOM 2
S251-3	Program audio 1
S251-4	Program audio 2
S252	Not used.

### ⑫ S253 switches

These switches select the audio to be output to the TRACKER connector.

Switch	Audio to be output
S253-1	Audio from INCOM 1
S253-2	Audio from INCOM 2
S253-3	Program audio 1

Switch	Audio to be output
S253-4	Program audio 2

## 4 DM-139 board

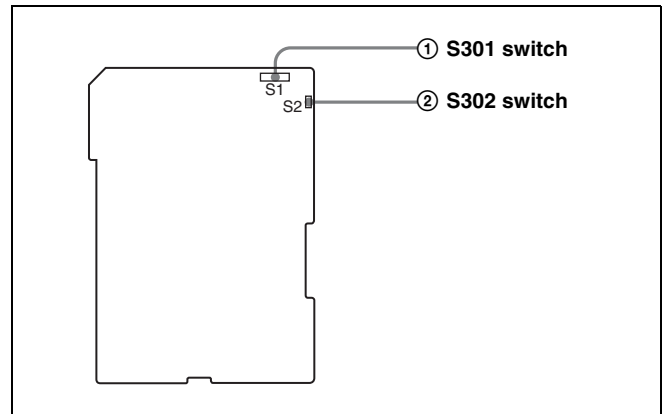

### ① S301 switch

Selects the direction of the prompter signal flow. The signal flow direction must also be changed on the CCU.

**RX:** The video signal from the CCU is output from the PROMPTER connector (factory-setting).

**REM:** Available in near future.

**TX:** The video signal input to the PROMPTER connector is output to the CCU. Note that the CCU-550D/550DP does not support this function.

### ② S302 switch

Selects the signal to be output from the PROMPTER connector.

**PROMPT:** Prompter video signal is output (factory-setting).

**RET:** Return video signal is output.

## 5 MB-1019 board

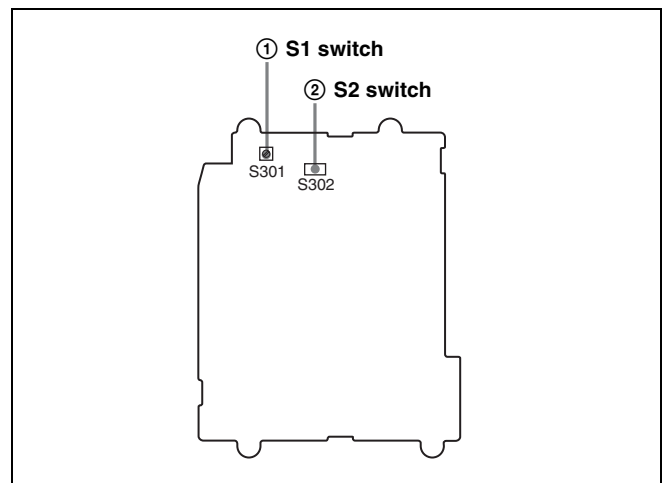

### ① S1 switch

Selects the signal to be output to the RETURN connector.

**RET:** Return video signal is output (factory-setting).

**MONI:** Monitor video signal is output.

**VBS:** Composite video signal is output.

### ② S2 switch

Selects the signal to be input/output from the PROMPTER connector.

**PROMPT:** Prompter video signal is input and output (factory-setting).

**REF:** Reference signal for the video camera is input.

# Preparations

## Attaching the CA-590/590P to a BVP-E10/E10P/E10WS/E10WSP/E30/E30P/E30WS/E30WSP Color Video Camera

When you attach the CA-590/590P to a BVP-E10/E10P/E10WS/E10WSP/E30/E30P/E30WS/E30WSP Color Video Camera as shown below, the 68-pin connectors on both units are automatically connected.

- 1 Attach the CA-590/590P to the rear of the color video camera.

Hook the upper part, then push the lower part in until it snaps into place.

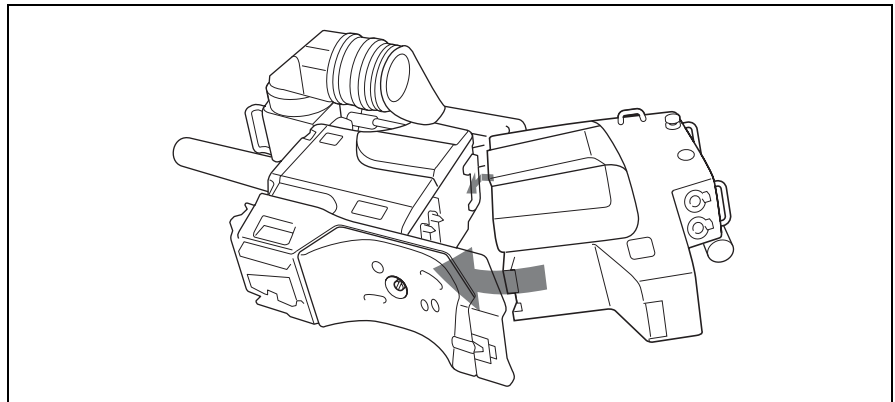

- 2 Tighten the screw with a coin.

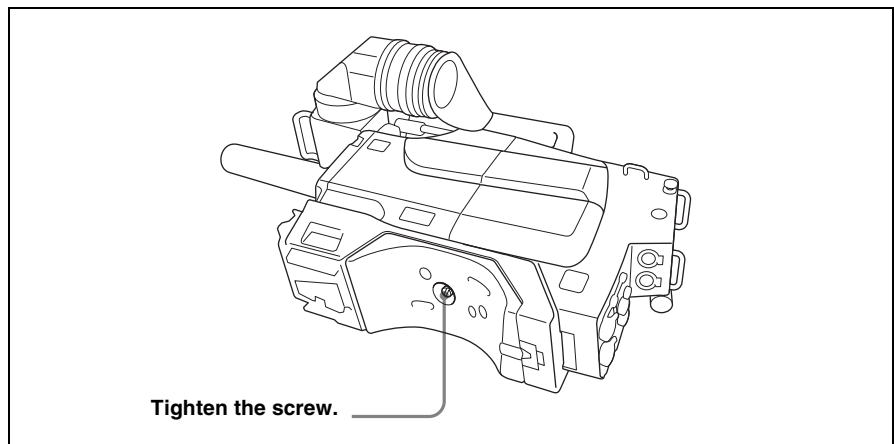

## Removing a Camera Adaptor

Loosen the screw on the video camera until it stops, then remove the camera adaptor while pushing the screw.

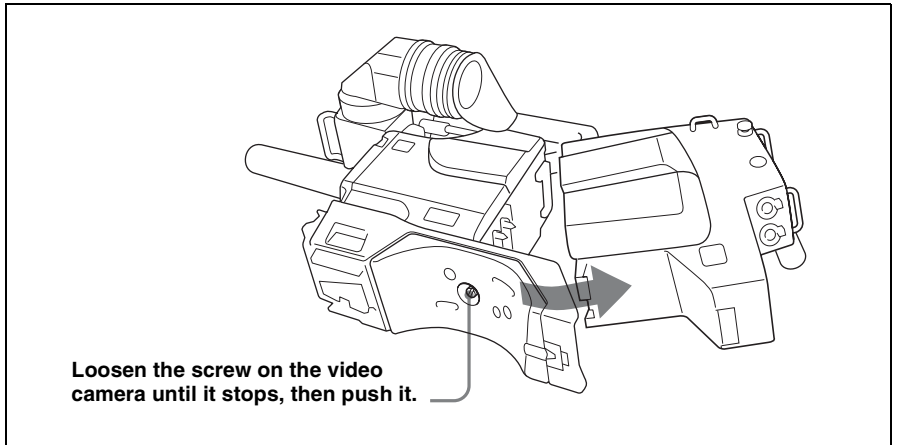

## Securing the triax cable to the camera adaptor

- 1 Attach the supplied cable holder with the supplied two M3 × 6 screws.

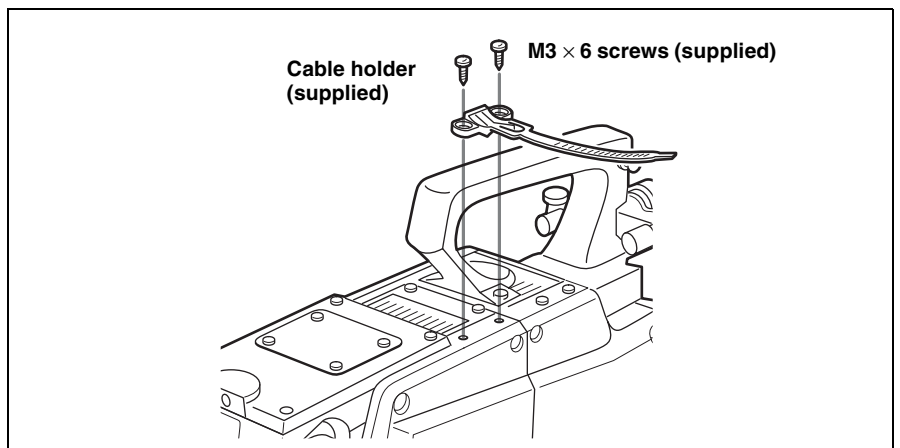

- 2 Route the triax cable as illustrated below, then fasten the cable holder around the cable.

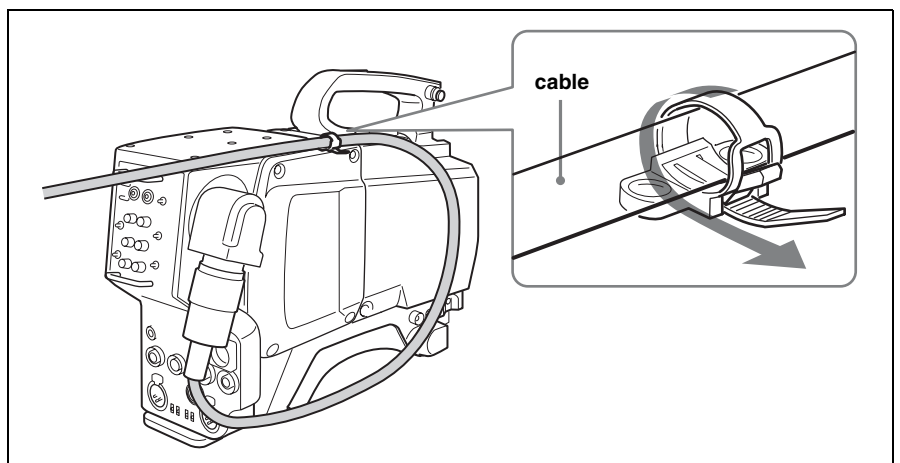

## Removing the cable from the cable holder

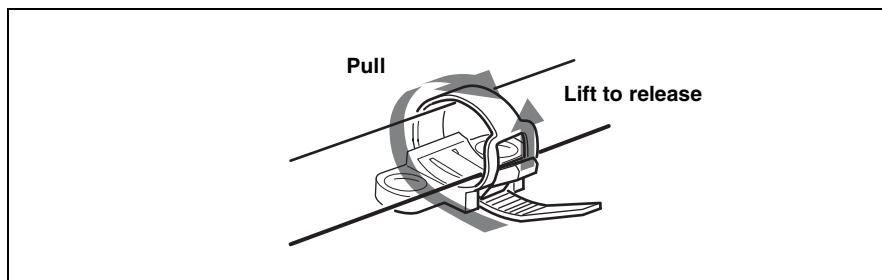



# Connections

## Connectable equipment

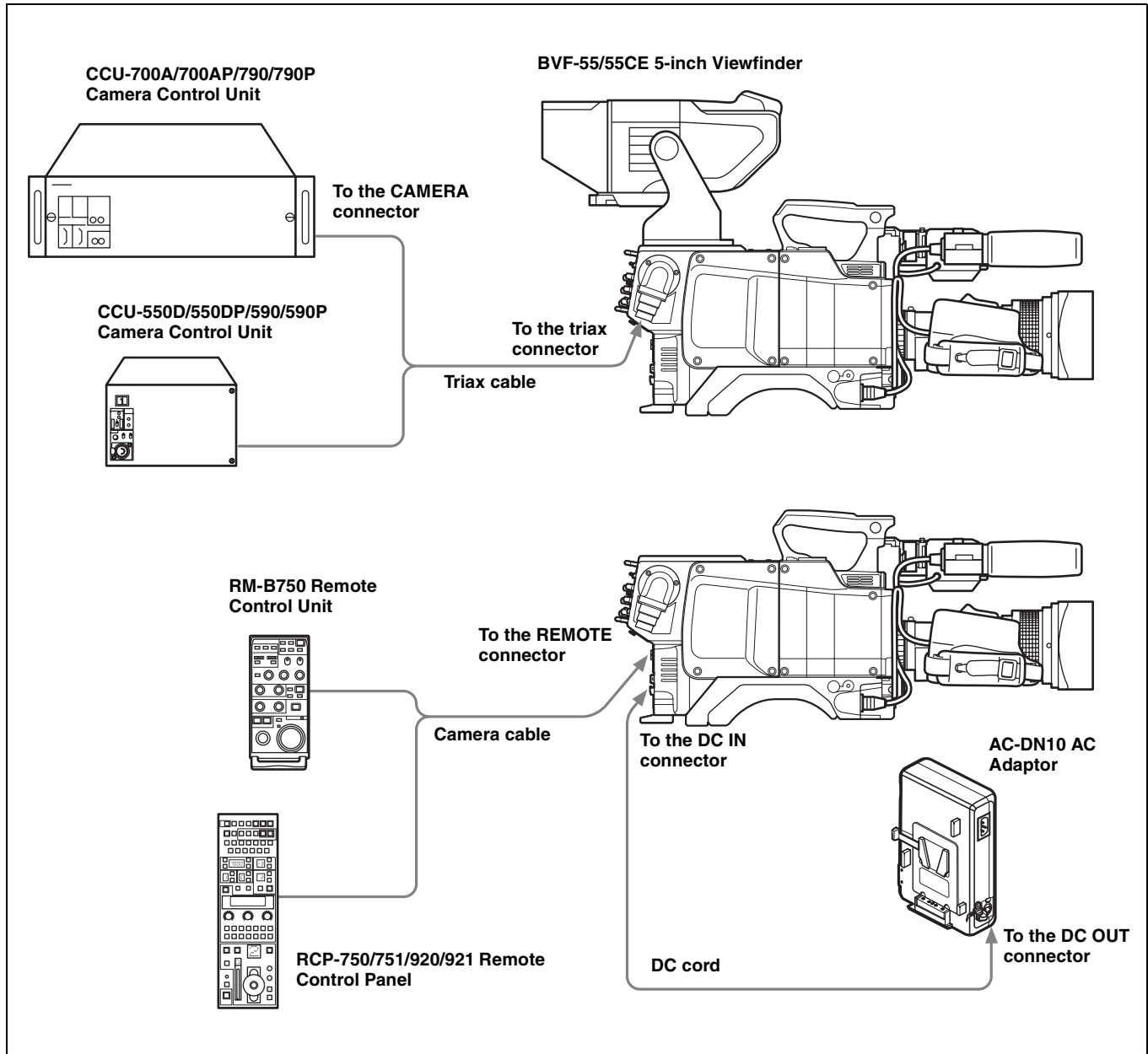

## Power supply

### When a Camera Control Unit is connected

Set the POWER switch to CCU to supply power to the CA-590/590P from the CCU.

### To supply power from the DC connector

Set the POWER switch to EXT.

# Self-Diagnostics

When the CA-590/590P is connected to the BVP-E10/E10P/E10WS/E10WSP/E30/E30P/E30WS/E30WSP, you can display the results of self-diagnostics of the CA-590/590P internal boards using the DIAGNOSIS menu of the video camera. The self-diagnostics results can be monitored on the camera's viewfinder.

## Displaying the DIAGNOSIS menu

Refer to the Operating Instructions supplied with the video camera.

## The contents of the self-diagnostics results

For the BVP-E10/E10P/E10WS/E10WSP or for the BVP-E30/E30P/E30WS/E30WSP whose camera software version is earlier than 1.03

```
<DIAGNOSIS>
ROM:V1.00
CAMERA:UC
OHB:--
VA:--
DPR:--
IF:--
AT:--
HUR:99999H
CCU:--
```

CA-570
MD:--
AU:--
TR:--

Self-diagnostics results of the CA-590/590P internal boards

**CA-570:** Model name of the CA (appears as "CA-570" even when the CA-590/590P is connected).

**MD:** Status of the internal MD board

**AU:** Status of the internal AU board

**TR:** Status of the internal TR board

When an abnormality is detected, "NG" appears for the corresponding internal board.

When an abnormality is detected on the fan of the CA power unit, "-" and "NG" alternate on all the internal board status indications.

And when "NG" appears on all the internal board status indications, an abnormality may have occurred on the CA power unit.

### Note

The camera software upgrade can be done only on the BVP-E30/E30P/E30WS/E30WSP.

For the BVP-E30/E30P/E30WS/E30WSP whose camera software version is 1.03 or later

```
<DIAGNOSIS>
ROM:V1.03
CAMERA:UC
OHB:--
VA:--
DPR:--
IF:--
AT:--
HUR:99999H
CCU:--
```

CA-590
MD:--
AU:--
TR:--
MA:--
FAN:--

Self-diagnostics results of the CA-590/590P internal boards

**CA-590:** Model name of the CA

**MD:** Status of the internal MD board

**AU:** Status of the internal AU board

**TR:** Status of the internal TR board

**MA:** Status of the internal MA board

**FAN:** Status of the fan on the CA power unit

---

# Specifications

---

## General

Power consumption	8 W (within the CA-590/590P)
Operating temperature	-20°C to +45°C (-4°F to +113°F)
Storage temperature	-20°C to +50°C (-4°F to +122°F)
Dimensions	120 × 211 × 202 mm (w/h/d) (4 <sup>3</sup> / <sub>4</sub> × 8 <sup>3</sup> / <sub>8</sub> × 8 inches)
Mass	2.8 kg (6 lb 3 oz)

---

## Input/output connectors

AUDIO IN CH 1/2 (2ch)	XLR type 3-pin, Female, 600 ohms, balanced
DC IN	XLR type, 4-pin, DC 10.5 to 17 V
DC OUT*	4-pin, DC 10.5 to 17V, Max. 1.5 A
RETURN	BNC type, 1Vp-p, 75 ohms
PROMPTER	BNC type, 1Vp-p, 75 ohms
RET CTRL	6-pin
EARPHONE	Mini-jack, 8 ohms
CAMERA I/F	68-pin
CCU	Triax
INCOM 1/2 (2ch)	XLR type, 5-pin, Female
REMOTE	8-pin
TRACKER	10-pin

\* When a 5-inch viewfinder is connected to this unit or the TRACKER connector or the REMOTE connector is used, the maximum 1.5 A DC output cannot be obtained from the DC OUT connector.

---

## Supplied accessories

Carrying belt (1)  
Cable holder (2)  
M3 × 6 screws (4)  
Operation Manual (1)  
CD-ROM (1)

---

## Optional accessories

CAC-6 Return Video Selector  
BVF-55/55CE Viewfinder  
RM-B750 Remote Control Unit

Design and specifications are subject to change without notice.

### Note

Always verify that the unit is operating properly before use. SONY WILL NOT BE LIABLE FOR DAMAGES OF ANY KIND INCLUDING, BUT NOT LIMITED TO, COMPENSATION OR REIMBURSEMENT ON ACCOUNT OF THE LOSS OF PRESENT OR PROSPECTIVE PROFITS DUE TO FAILURE OF THIS UNIT, EITHER DURING THE WARRANTY PERIOD OR AFTER EXPIRATION OF THE WARRANTY, OR FOR ANY OTHER REASON WHATSOEVER.



The material contained in this manual consists of information that is the property of Sony Corporation and is intended solely for use by the purchasers of the equipment described in this manual.

Sony Corporation expressly prohibits the duplication of any portion of this manual or the use thereof for any purpose other than the operation or maintenance of the equipment described in this manual without the express written permission of Sony Corporation.



CA-590/590P  
(UC/CE)  
3-869-644-02 (1)

**Sony Corporation**  
<http://www.sony.net/>

Printed in Belgium  
2007.04.08  
© 2005

## Free Manuals Download Website

<http://myh66.com>

<http://usermanuals.us>

<http://www.somanuals.com>

<http://www.4manuals.cc>

<http://www.manual-lib.com>

<http://www.404manual.com>

<http://www.luxmanual.com>

<http://aubethermostatmanual.com>

Golf course search by state

<http://golfingnear.com>

Email search by domain

<http://emailbydomain.com>

Auto manuals search

<http://auto.somanuals.com>

TV manuals search

<http://tv.somanuals.com>