

LCD Digital Color TV

Operating Instructions

BRAVIA

KDL-26S2000 KDL-32S2000
KDL-40S2000

Owner's Record

The model and serial numbers are located at the rear of the TV. Record these numbers in the spaces provided below. Refer to them whenever you call upon your Sony dealer regarding this product.

Model No. _____

Serial No. _____

Contacting Sony

If, after reading the following instructions, you have additional questions related to the use of your Sony® TV, please call one of the following numbers.

Customers in the United States contact the Direct Response Center at:

1-800-222-SONY (7669)

or visit <http://www.sony.com/TVsupport>

Customers in Canada contact the Customer Relations Center at:

1-877-899-SONY (7669)

or visit <http://www.sony.com/TVsupport>

WARNING

To reduce the risk of fire or electric shock, do not expose this apparatus to rain or moisture.



This symbol is intended to alert the user to the presence of uninsulated "dangerous voltage" within the product's enclosure that may be of sufficient magnitude to constitute a risk of electric shock to persons.



This symbol is intended to alert the user to the presence of important operating and maintenance (servicing) instructions in the literature accompanying the appliance.

CAUTION

To prevent electric shock, do not use this polarized AC plug with an extension cord, receptacle or other outlet unless the blades can be fully inserted to prevent blade exposure.

Note on Caption Vision

This TV provides display of TV closed captioning in accordance with §15.119 of the FCC rules.

For Customers in the United States

If you have any questions about this product, you may call; Sony Customer Information Services Center 1-800-222-7669 or <http://www.sony.com/>

Declaration of Conformity

Trade Name: SONY
Model: KDL-26S2000/KDL-32S2000/
KDL-40S2000
Responsible Party: Sony Electronics Inc.
Address: 16530 Via Esprillo,
San Diego, CA 92127 U.S.A.
Telephone Number: 858-942-2230

This device complies with part 15 of the FCC rules. Operation is subject to the following two conditions: (1) This device may not cause harmful interference, and (2) this device must accept any interference received, including interference that may cause undesired operation.

NOTIFICATION

This equipment has been tested and found to comply with the limits for a Class B digital device, pursuant to Part 15 of the FCC Rules. These limits are designed to provide reasonable protection against harmful interference in a residential installation. This equipment generates, uses and can radiate radio frequency energy and, if not installed and used in accordance with the instructions, may cause harmful interference to radio communications. However, there is no guarantee that interference will not occur in a particular installation. If this equipment does cause harmful interference to radio or television reception, which can be determined by turning the equipment off and on, the user is encouraged to try to correct the interference by one or more of the following measures:

- Reorient or relocate the receiving antenna.
- Increase the separation between the equipment and receiver.
- Connect the equipment into an outlet on a circuit different from that to which the receiver is connected.
- Consult the dealer or an experienced radio/TV technician for help.

Pursuant to FCC regulations, you are cautioned that any changes or modifications not expressly approved in this manual could void your authority to operate this equipment.

For Customers in Canada

This Class B digital apparatus complies with Canadian ICES-003.

Safety

- Operate the TV only on 120-240 V AC.
- Use the AC power cord specified by Sony and suitable for the voltage where you use it.
- The plug is designed, for safety purposes, to fit into the wall outlet only one way. If you are unable to insert the plug fully into the outlet, contact your dealer.
- If any liquid or solid object should fall inside the cabinet, unplug the TV immediately and have it checked by qualified service personnel before operating it further.
- If you will not be using the TV for several days, disconnect the power by pulling the plug itself. Never pull on the cord.
- For details concerning safety precautions, see "Important Safety Instructions" on page 4.

Installing

- The TV should be installed near an easily accessible power outlet.
- To prevent internal heat buildup, do not block the ventilation openings.
- Do not install the TV in a hot or humid place, or in a place subject to excessive dust or mechanical vibration.

- Avoid operating the TV at temperatures below 41°F (5°C).
- If the TV is transported directly from a cold to a warm location, or if the room temperature changes suddenly, the picture may be blurred or show poor color due to moisture condensation. In this case, please wait a few hours to let the moisture evaporate before turning on the TV.
- To obtain the best picture, do not expose the screen to direct illumination or direct sunlight. It is recommended to use spot lighting directed down from the ceiling or to cover the windows that face the screen with opaque drapery. It is desirable to install the TV in a room where the floor and walls are not of a reflective material.

CAUTION

Use the following Sony appliance(s) only with the following WALL-MOUNT BRACKET.

Sony Appliance Model No.		
	KDL-26S2000	KDL-40S2000
	KDL-32S2000	
Sony Wall-Mount Bracket Model No.	SU-WL31	SU-WL51

Use with other WALL-MOUNT BRACKET may cause instability and possibly result in injury.

To Customers

Sufficient expertise is required for installing the specified product. Be sure to subcontract the installation to Sony dealers or licensed contractors and pay adequate attention to safety during the installation.

For Customers in the United States

This product contains mercury. Disposal of this product may be regulated if sold in the United States. For disposal or recycling information, please contact your local authorities or the Electronics Industries Alliance (<http://www.eiae.org>).

Note

This television includes a QAM demodulator which should allow you to receive unscrambled digital cable television programming via subscription service to a cable service provider. Availability of digital cable television programming in your area depends on the type of programming and signal provided by your cable service provider.

(Continued)

Trademark Information

TruSurround XT, SRS and (●) symbol are trademarks of SRS Labs, Inc. TruSurround XT technology is incorporated under license from SRS Labs, Inc.

Manufactured under license from BBE Sound, Inc.

Licensed by BBE Sound, Inc. under one or more of the following US patents: 5510752, 5736897. BBE and BBE symbol are registered trademarks of BBE Sound, Inc.

Macintosh is a trademark licensed to Apple Computer, Inc., registered in the U.S.A and other countries.

“BRAVIA” and BRAVIA are trademarks of Sony Corporation.



As an ENERGY STAR® Partner, Sony Corporation has determined that this product meets the ENERGY STAR® guidelines for energy efficiency.

ENERGY STAR® is a U.S. registered mark.





This TV incorporates High-Definition Multimedia Interface (HDMI™) technology.

HDMI, the HDMI logo and High-Definition Multimedia Interface are trademarks or registered trademarks of HDMI Licensing, LLC.



Manufactured under license from Dolby Laboratories. “Dolby” and the double-D symbol are trademarks of Dolby Laboratories.

Important Safety Instructions

- 1) Read these instructions.
- 2) Keep these instructions.
- 3) Heed all warnings.
- 4) Follow all instructions.
- 5) Do not use this apparatus near water.
- 6) Clean only with dry cloth.
- 7) Do not block any ventilation openings. Install in accordance with the manufacturer’s instructions.
- 8) Do not install near any heat sources such as radiators, heat registers, stoves, or other apparatus (including amplifiers) that produce heat. A diagram showing a television set with several heat sources (radiators, stoves, etc.) nearby, with arrows indicating heat being directed towards the TV.
- 9) Do not defeat the safety purpose of the polarized or grounding-type plug. A polarized plug has two blades with one wider than the other. A grounding type plug has two blades and a third grounding prong. The wide blade or the third prong are provided for your safety. If the provided plug does not fit into your outlet, consult an electrician for replacement of the obsolete outlet.
- 10) Protect the power cord from being walked on or pinched particularly at plugs, convenience receptacles, and the point where they exit from the apparatus.
- 11) Only use attachments/accessories specified by the manufacturer.
- 12) Use only with the cart, stand, tripod, bracket, or table specified by the manufacturer, or sold with the apparatus. When a cart is used, use caution when moving the cart/apparatus combination to avoid injury from tip-over. A warning icon showing a television set on a cart that is tipping over, with a person nearby.
- 13) Unplug this apparatus during lightning storms or when unused for long periods of time.
- 14) Refer all servicing to qualified service personnel. Servicing is required when the apparatus has been damaged in any way, such as power-supply cord or plug is damaged, liquid has been spilled or objects have fallen into the apparatus, the apparatus has been exposed to rain or moisture, does not operate normally, or has been dropped.

Use

For the unit with a three-wire grounding type AC power cord plug (Class 1 unit)

This unit must be connected to an AC power socket outlet with a protective earthing connection.

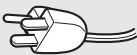

Wall outlet

Do not use a poor fitting outlet.

Insert the plug fully into the outlet. If it is loose, it may cause arcing and result in a fire.

Contact your electrician to have the outlet changed.



Wiring

For your safety, unplug the AC power cord when wiring cables.

Electric shock

Do not touch the AC power cord or the unit with a wet hand. If you plug/unplug the AC power cord from the unit with a wet hand, it may cause electric shock.



Cleaning

- Clean the AC power plug regularly. If the plug is covered with dust and it picks up moisture, its insulation may deteriorate and result in a fire. Unplug the AC power plug and clean it regularly.
- Unplug the AC power cord when cleaning this unit. If not, it may result in electric shock.
- Clean the cabinet of the TV with a dry soft cloth. To remove dust from the screen, wipe it gently with a soft cloth. Stubborn stains may be removed with a cloth slightly dampened with a solution of mild soap and warm water. Never use strong solvents such as thinner or benzine for cleaning.
- If using a chemically pretreated cloth, please follow the instruction provided on the package.
- If the picture becomes dark after using the TV for a long period of time, it may be necessary to clean the inside of the TV. Consult qualified service personnel.

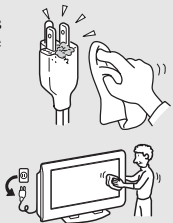

Magnetic influence

This TV contains a strong magnet in the speaker unit that generates a magnetic field. Keep any items susceptible to magnetic fields away from the speaker.

Sound

If a snapping or popping sound from the TV is continuous or frequent while the TV is operating, unplug the TV and consult your dealer or service technician. It is normal for some TV's to make occasional snapping or popping sounds, particularly when being turned on or off.

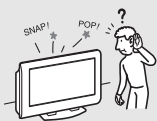

AC power cord

If you damage the AC power cord, it may result in a fire or an electric shock.

- Do not pinch, bend, or twist the cord excessively. The core lines may be bared and cut, and cause a short-circuit, resulting in a fire or an electric shock.
 - Do not convert or damage the AC power cord.
 - Do not put anything heavy on the AC power cord. Do not pull the AC power cord.
 - Keep the AC power cord away from heat sources.
 - Be sure to grasp the plug when disconnecting the AC power cord.
- If the AC power cord is damaged, stop using it and ask your dealer or Sony service center to exchange it.

Batteries

Do not dispose of batteries in a fire.

Do not short circuit, disassemble or overheat the batteries.

Caution

Danger of explosion if battery is incorrectly replaced. Replace only with the same or equivalent type.

Disposal of used batteries

To preserve our environment, dispose of used batteries according to your local laws or regulations.

Objects and ventilation holes

Never push objects of any kind into the unit through the cabinet slots as they may touch dangerous voltage points or short out parts that could result in a fire or electric shock. Never spill liquid of any kind on the unit.

Do not place any objects on the unit.

The apparatus shall not be exposed to dripping or splashing and no objects filled with liquids, such as vases, shall be placed on the apparatus.



Attachments

Do not use attachments not recommended by the manufacturer, as they may cause hazards.

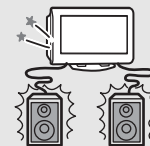

Medical institution

Do not place this unit in a place where medical equipment is in use.

It may cause a malfunction of medical instruments.



Moisture and flammable objects

- Do not use power-line operated sets near water — for example, near a bathtub, washbowl, kitchen sink, or laundry tub, in a wet basement, or near a swimming pool, etc. It may result in a fire or an electric shock.
- Do not let this unit get wet. Never spill liquid of any kind on the unit. If any liquid or solid object does fall through, do not operate the unit. It may result in electric shock or damage to the unit. Have it checked immediately by qualified personnel.
- To prevent fire, keep flammable objects or open flame (e.g. candles) away from the unit.



(Continued)

Broken pieces

Do not throw anything at the unit.
The screen glass may break by the impact and cause serious injury.

Cable wiring

Take care not to catch your feet on the cables. It may damage the unit.

Volume adjustment

- Adjust the volume so as not to trouble your neighbors. Sound carries very easily at night time. Therefore, closing the windows or using headphones is suggested.
- When using headphones, adjust the volume so as to avoid excessive levels, as hearing damage may result.

Disposal of the TV

- Do not dispose of the TV with general household waste.
- The LCD contains a small amount of liquid crystal. The fluorescent tube used in this display also contains mercury. Follow your local ordinances and regulations for disposal.

Handling of broken glass and liquid crystal leakage

If the LCD panel gets damaged, crystalline liquid leakage may occur, or scattered broken glass may result. Do not touch broken glass or crystalline liquid (which is toxic), with bare hands as cuts or poisoning/skin irritation may occur. Also, do not let glass fragments or leaked crystalline liquid get into your eyes or mouth. Should either contact your eyes or mouth, rinse the contacted area thoroughly with water and consult your doctor.

LCD screen

- Although the LCD screen is made with high-precision technology and has effective pixels of 99.99% or more, black dots or bright points of light (red, blue, or green) may appear constantly on the LCD screen. This is a structural property of the LCD panel and is not a malfunction.
- Do not expose the LCD screen surface to the direct sun light. Doing so may damage the LCD panel.
- Do not push or scratch the LCD screen, or place objects on top of the TV. The image may be uneven or the LCD panel may be damaged.
- If the TV is used in a cold place, a smear may occur in the picture or the picture may become dark. This does not indicate a failure. These phenomena improve as the temperature rises.
- Ghosting may occur when still pictures are displayed continuously. It should disappear after a few moments.
- The screen and cabinet get warm when the TV is in use. This is not a malfunction.
- Avoid spraying insect repellent with volatile material to the screen.
- Avoid prolonged contact with rubber or plastic made material.

Fluorescent lamp

This TV uses a special fluorescent lamp as its light source. If the screen image becomes dark, flickers, or does not appear, the fluorescent lamp has run down and should be replaced. For replacement, consult qualified service personnel.

Carry the TV in the specified manner

Carrying the TV requires at least two people.

If you carry the TV in a manner other than that specified and without the specified number of persons, it may drop and serious injury may result.

- Carry the TV with the specified number of persons.
- Carry the TV holding the upper and bottom frames of the TV as illustrated.
- Hold the TV securely when carrying it.
- As the glass surface of the TV has a special coating, be careful to avoid touching the glass surface as much as possible.



- When transporting, do not subject the unit to shocks or vibration, or excessive force.

Installation

When installing or removing the TV on the wall, be sure to use qualified contractors. Wall mount installation requires the use of a wall-mount bracket. If the TV is installed or removed from the wall by a person other than a qualified contractor, the unit may fall and cause serious injury if the unit is not installed securely.



Placement for viewing

It is recommended to watch the TV at a distance of 3 - 7 times that of the screen height, and in moderate brightness. Watching the TV for too long or in a dark room will cause eye fatigue.

Optional accessories

Observe the following when installing the TV using a wall-mount bracket. If the TV is not secured properly, it may fall and cause injury.

- Be sure to follow the operating instructions supplied with the wall-mount bracket when installing the unit.
- Be sure to attach the brackets supplied with the wall-mount bracket.



Oils

Do not install this unit in restaurants where oily vapors occur. Dust absorbing oil may enter into the unit and damage the unit.

Corrosion

If you use this unit near the seashore, salt may corrode metal parts of the unit and cause internal damage or fire. It may also shorten the life of the unit.

Ventilation

The slots and openings in the TV are provided for necessary ventilation. To ensure reliable operation of the unit, and to protect it from overheating, these slots and openings must never be blocked or covered. Unless proper ventilation is provided, the unit may gather dust and get dirty. For proper ventilation, observe the following:

- Do not install the unit turned backward or sideways.
- Do not install the unit turned over or upside down.
- Never cover the slots and openings with a cloth or other materials.



- Never block the slots and openings by placing the unit on a bed, sofa, rug or other similar surface.



- Never place the unit in a confined space, such as a bookcase or built-in cabinet, unless proper ventilation is provided.



When installing the unit on the wall, allow this much space.

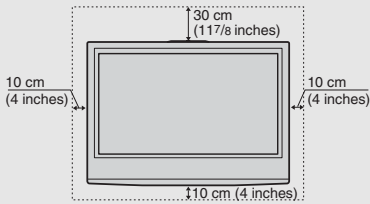

When installing the unit using a stand, allow this much space.

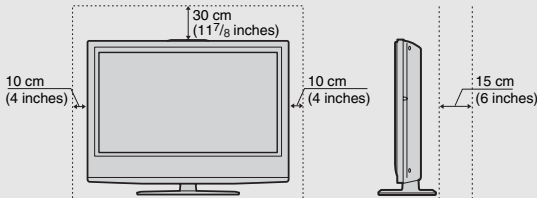

Never install the unit as follows:

Air circulation is blocked.

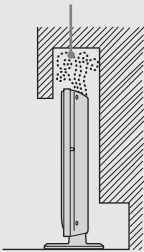

Air circulation is blocked.

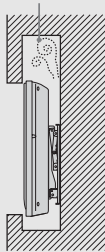

Outdoor use

Do not install this unit outdoors. If the unit is exposed to rain, it may result in a fire or an electric shock. If the unit is exposed to direct sunlight, the unit may heat up and cause damage to the unit.

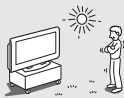

Vehicle and ceiling

Do not install this unit in a vehicle or hang from the ceiling.

Bumping of the vehicle may cause the unit to fall down and cause injury.



Ship and vessel

Do not install this unit in a ship or vessel. If the unit is exposed to seawater, it may cause a fire or damage the unit.



Preventing the TV from toppling over

Take measures to prevent the unit from toppling over and causing injury. To prevent the unit from toppling over, secure the unit to the wall or pillar.

Installing on a level surface

If you install the unit on an inclined surface, the unit may fall or drop and cause injury or damage.



Placing on a stable surface

If you place the unit on an unstable surface, the unit may fall and cause injury or damage.



Fall

Do not hang anything on the unit. The unit may fall from the stand or wall-mount, causing damage or serious injury.



AC power cord

Unplug the AC power cord when moving the unit. Do not move the unit with the AC power cord plugged in. It may damage the AC power cord and result in a fire or an electric shock. Do not allow anything to rest on or roll over the power cord, and do not place the unit where the power cord is subject to wear or abuse.



Antennas

Outdoor Antenna Grounding

If an outdoor antenna is installed, follow the precautions below. An outdoor antenna system should not be located in the vicinity of overhead power lines or other electric light or power circuits, or where it can come in contact with such power lines or circuits.

WHEN INSTALLING AN OUTDOOR ANTENNA SYSTEM, EXTREME CARE SHOULD BE TAKEN TO KEEP FROM CONTACTING SUCH POWER LINES OR CIRCUITS AS CONTACT WITH THEM IS ALMOST INVARIABLY FATAL.

Be sure the antenna system is grounded so as to provide some protection against voltage surges and built-up static charges.

Section 810 of the National Electrical Code (NEC) in USA and Section 54 of the Canadian Electrical Code in Canada provides information with respect to proper grounding of the mast and supporting structure, grounding of the lead-in wire to an antenna discharge unit, size of grounding conductors, location of antenna discharge unit, connection to grounding electrodes, and requirements for the grounding electrode.

Antenna Grounding According to the National Electrical Code, ANSI/NFPA 70

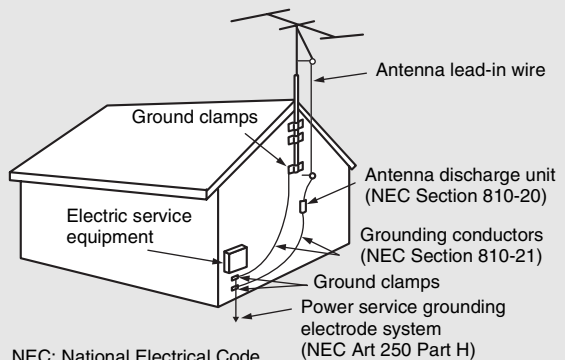

NEC: National Electrical Code

(Continued)

Lightning

For added protection for this TV during a lightning storm, or when it is left unattended and unused for long periods of time, unplug it from the wall outlet and disconnect the antenna. This will prevent damage to the receiver due to lightning and power-line surges.

Damage requiring service

If the surface of the TV cracks, do not touch it until you unplug the AC power cord.

Otherwise electric shock may result.

Servicing

Do not attempt to service the unit yourself since opening the cabinet may expose you to dangerous voltage or other hazards. Refer all servicing to qualified service personnel.



Replacement parts

When replacement parts are required, be sure the service technician certifies in writing that he/she has used replacement parts specified by the manufacturer that have the same characteristics as the original parts.

Unauthorized substitutions may result in a fire, an electric shock or other hazards.



Safety check

Upon completion of any service or repairs to the unit, ask the service technician to perform routine safety checks (as specified by the manufacturer) to determine that the unit is in safe operating condition, and to so certify. Ask a qualified service technician to dispose of the unit.



Contents

Getting Started

Connecting the TV	10
Cable System or VHF/UHF Antenna System.....	10
Cable Box/Digital Cable Box	10
Cable System and VHF/UHF Antenna System	11
Satellite Receiver and Cable/Antenna.....	12
VCR, Cable and Antenna.....	12
When Connecting to Optional Equipment	13
Installing the TV	15
Preventing the TV from Toppling Over.....	15
Bundling the Connecting Cables	16
Adjusting the Viewing Angle of the TV	16
Setting Up the Channel List - Initial Setup.....	17

Basic Operations

Remote Control	18
TV Controls.....	21

Introducing MENU Function

Overview of MENU	22
Navigating Through Settings	24
Using the Picture Settings	24
Using the Sound Settings	26
Using the Screen Settings.....	27
Using the Setup Settings.....	29
Using the PC Settings.....	34
Using the Analog Setup Settings	35
Using the Digital Setup Settings.....	36

Other Information

Troubleshooting.....	39
PC Input Signal Reference Chart.....	41
Specifications.....	42
Index.....	43

Getting Started

Connecting the TV

To display clear crisp pictures, you must connect your TV correctly and select the correct **Wide Mode** to display the picture in the correct aspect ratio (see “Changing the Wide Screen Mode” on page 20). It is strongly recommended to connect the antenna/cable input using the supplied 75-ohm coaxial cable to receive optimum picture quality signal. A 300-ohm twin lead cable can be easily affected by radio noise and the like, resulting in signal deterioration. If you use a 300-ohm twin lead cable, keep it as far away from the TV as possible.

You can also connect a variety of optional equipment to your TV (see page 13). For multiple equipment connections, please refer to the Quick Setup Guide.

Cable System or VHF/UHF Antenna System

Cable or VHF/UHF (or VHF only)

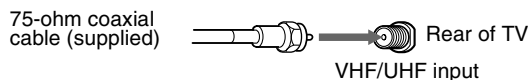

From the Setup settings, select Cable On or Cable Off for your type of input signal.

Cable Box/Digital Cable Box

💡 To change channels using the cable box, set your TV to channel 3 or 4 depending on the cable box channel output. Auto Scan will fix the channel automatically.

Use this hookup if

- You subscribe to a cable TV system that uses scrambled or encoded signals requiring a cable box to view all channels, and
- You do not intend to hook up any other audio or video equipment to your TV.

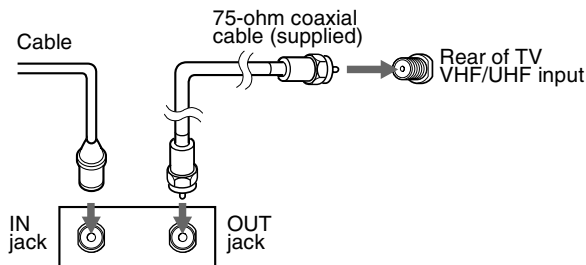

Also, set Cable to On in the Setup settings (see page 31).

Cable System and VHF/UHF Antenna System

If you want to watch both antenna (over-the-air) and cable broadcast signals, you'll need to use an optional A-B RF switch (not supplied), as shown below.

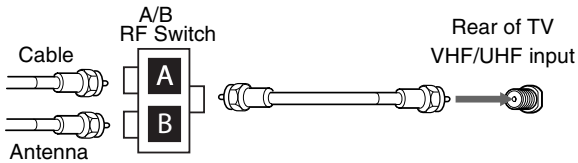

Use the A-B selector to switch between the over-the-air signals and the cable signals. Then set the Cable setting in the Setup settings to On or Off, as described on page 31.

Satellite Receiver and Cable/Antenna

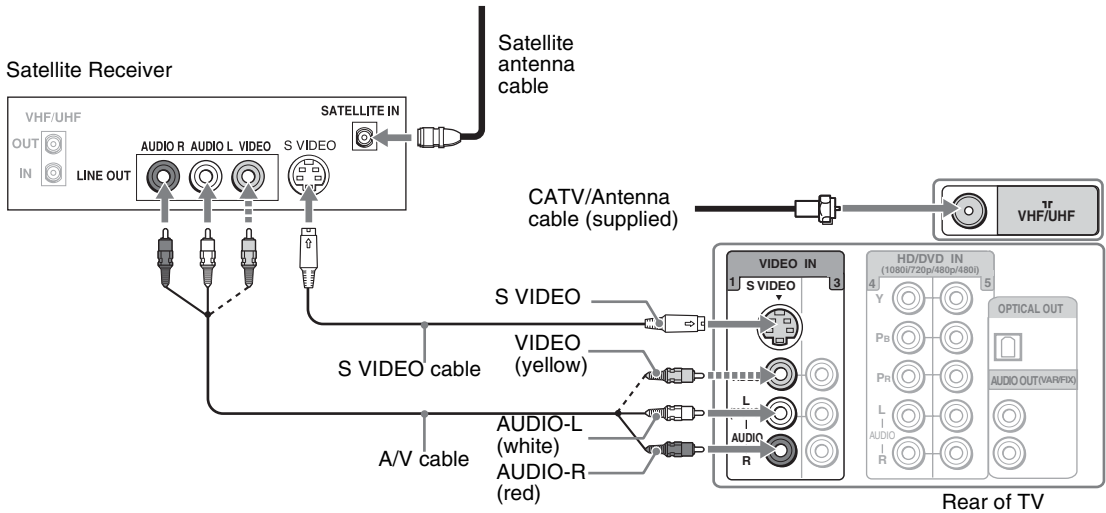

- ✎ If your satellite receiver is not equipped with S VIDEO, use a VIDEO cable (yellow) instead of the S VIDEO cable.
- ✎ Run the Initial Setup program, as described in “Setting Up the Channel List” on page 17 after completing your connections.

VCR, Cable and Antenna

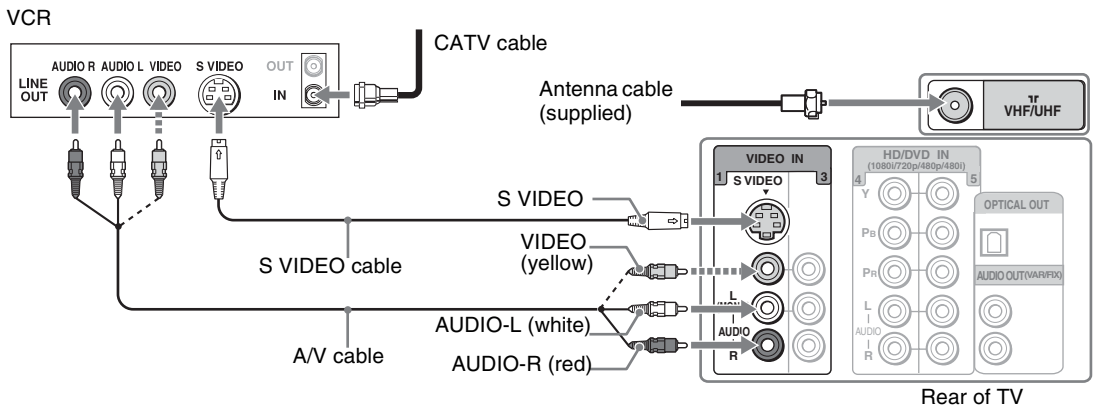

- ✎ If your VCR is not equipped with S VIDEO, use a VIDEO cable (yellow) instead of the S VIDEO cable.
- ✎ Run the Initial Setup program, as described in “Setting Up the Channel List” on page 17 after completing your connections.

When Connecting to Optional Equipment

Left side

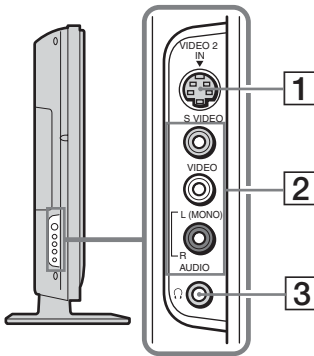

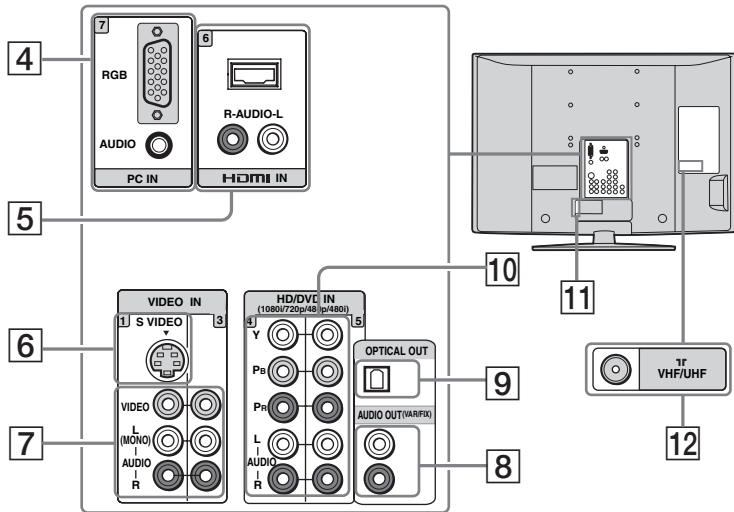

Rear



Item	Description
1	VIDEO 2 IN S VIDEO Connects to the S VIDEO output jack on your camcorder or other video equipment that has S VIDEO. Provides better picture quality than composite video (2). (See Auto YC on page 30.)
2	VIDEO 2 IN VIDEO/ L (MONO)- R AUDIO Connect to the composite video and audio output jacks on your camcorder or other video equipment such as video game equipment. If you have mono equipment, connect its audio output jack to the TV's L (MONO) audio input jack.
3	Headphones jack Connects to your headphones. If your headphones do not match the jack, use a suitable plug adapter (not supplied).
4	PC IN 7 (RGB/AUDIO) Connect to a personal computer's video output connector using HD15-HD15 cable (analog RGB, supplied). Can also be connected to other Analog RGB devices such as video conferencing or set-top boxes. See "PC Input Signal Reference Chart" on page 41 for the signals that can be displayed. For some Apple Macintosh computers, it may be necessary to use an adapter (not supplied). If this is the case, connect the adapter to the computer before connecting the HD15-HD15 cable. If the picture is noisy, flickering or not clear, adjust the Phase and Pitch of the PC Settings on page 34.

(Continued)

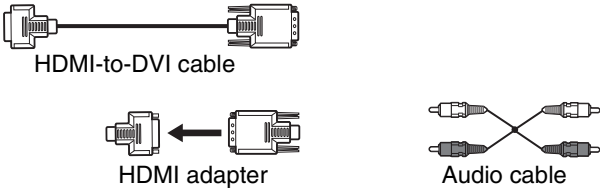
Getting Started

Item	Description
5 HDMI IN 6 HDMI/ R-AUDIO-L	<p>HDMI (High-Definition Multimedia Interface) provides an uncompressed, all-digital audio/video interface between this TV and any HDMI-equipped audio/video equipment, such as a set-top box, DVD player, and A/V receiver. HDMI supports enhanced, or high-definition video, plus digital audio.</p> <p>If the equipment has a DVI jack and not an HDMI jack, connect the DVI jack to the HDMI IN (with HDMI-to-DVI cable and/or adapter) jack, and connect the audio jack to the AUDIO IN(L/R) jacks of HDMI IN. (DVI connector is for video signals only.)</p> <div style="text-align: center;">  <p>The diagram illustrates three types of cables used for connecting external equipment to the TV's HDMI IN port. On the left is an 'HDMI-to-DVI cable' which has an HDMI connector on one end and a DVI connector on the other. In the middle is an 'HDMI adapter' which is a small rectangular device with an HDMI port on one side and a DVI port on the other. On the right is an 'Audio cable' which has two RCA connectors (one red, one white) on one end and two 3.5mm audio jacks on the other.</p> </div>
	<p> Do not connect a PC to the TV's HDMI input. Use the PC IN (RGB IN) connector instead when connecting a PC.</p>
6 VIDEO IN 1 S VIDEO	<p>Connects to the S VIDEO output jack of your VCR or other video equipment that has S VIDEO. S VIDEO provides better picture quality than the composite video (7).</p> <p> Component video (YPbPr) or HDMI connection is necessary to view 480p, 720p, and 1080i formats. Note that this TV displays all format types of picture in a resolution of 1,366 dots × 768 lines.</p>
7 VIDEO IN 1/3 VIDEO/ L(MONO)- AUDIO-R	<p>Connect to the composite video and audio output jacks on your A/V equipment such as a VCR or other video equipment. A third composite video and audio (VIDEO 2) is located on the left side panel of the TV.</p>
8 AUDIO OUT (VAR/FIX)	<p>Connect to the left and right audio input jacks of your audio or video equipment. You can use these outputs to listen to your TV's audio through your stereo system.</p>
9 OPTICAL OUT (PCM/DOLBY* DIGITAL)	<p>Connects to the optical audio input of a digital audio equipment that is PCM/Dolby digital compatible. (OPTICAL OUT is only available for digital channels.)</p>
10 HD/DVD IN 4/5 (1080i/720p/ 480p/480i)/ L-AUDIO-R	<p>Connect to your DVD player's or digital set-top box's component video (YPbPr) and audio (L/R) jacks. Component video provides better picture quality than the S VIDEO (6) or the composite video (7) connections.</p>
11 AC IN	<p>Connects the supplied AC power cord.</p>
12 VHF/UHF	<p>RF input that connects to your cable or VHF/UHF.</p>

* Manufactured under license from Dolby Laboratories. "Dolby" and the double-D symbol are trademarks of Dolby Laboratories.



Installing the TV

Preventing the TV from Toppling Over

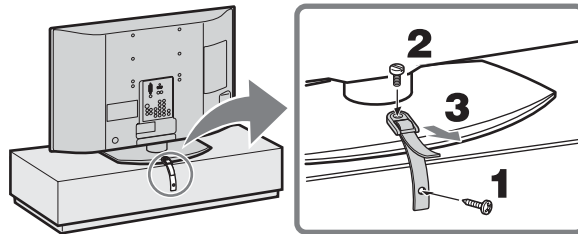
Attaching the Support Belt



- 1** Screw the support belt (supplied) to the TV stand with a wood screw (supplied).
- 2** Attach the support belt to the stand, and screw the belt with a securing screw (supplied) using a coin, etc.
- 3** Adjust the length by pulling the support belt towards you while holding the TV stand.

-  Be sure to take measures to prevent the TV from toppling over and causing injury.
-  The supplied wood screw may not be used depending on the type of TV stand. In this case, or when the securing strength is not enough, prepare commercial screws to fit to the TV stand. Use commercial screws of 3 to 4 mm (1/8 to 3/16 inches) diameter. Consult your dealer about the types of screw.

When Mounting on a Wall

Refer to the Instruction Guide supplied with the wall-mount bracket on how to mount the TV to the wall.

Bundling the Connecting Cables

You can bundle the connecting cables as illustrated below.

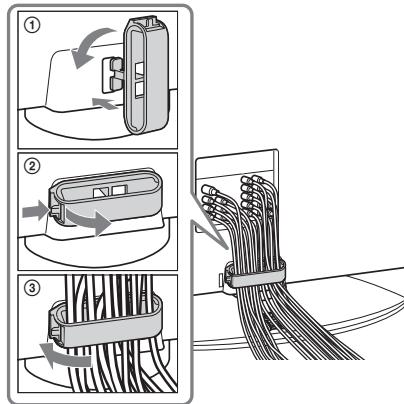



 Do not bundle the AC power cord in the stand with other connecting cables.

Adjusting the Viewing Angle of the TV

This TV can be adjusted within the angles shown below.

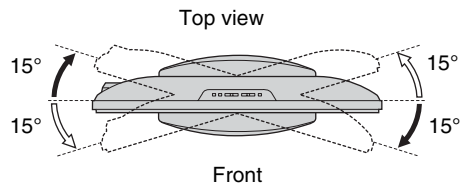
Adjust the angle left and right (swivel)











 When adjusting the angle, hold the stand with one hand to avoid slipping or tipping the stand.



Setting Up the Channel List - Initial Setup

After you finish connecting your TV, you need to run Initial Setup, which automatically sets up available channels. The Initial Setup screen appears when you turn on your TV for the first time. If you do not want to set up the channels at this time, you can do it later by selecting the Auto Program option in the Analog and Digital Setup settings (see pages 35 and 36).

 The default setting for channel selection is Cable On. For antenna connections, run the Auto Program again after selecting Cable Off from the Setup settings.

- 1 Press  to turn on the TV.
The Initial Setup screen appears.
- 2 Press  to highlight the on-screen display language. Then press .
The message “First please connect cable/antenna. Do you want to start Auto Program?” appears.
- 3 Press  to highlight “OK” then press .
The message “Auto Program” appears. Then the message “Continue programming digital channels?” appears. This may require 50+ minutes for completion.
- 4 Press  to highlight “OK” then press .

 If you selected “Cancel” during the Initial Setup, the Initial Setup message will appear each time you turn on the TV as a reminder until you complete the Auto Program.

To run Auto Program again at a later time

- Use the Auto Program feature as described on pages 35 and 36.

To add individual digital channels

- Use the Digital Channels feature as described on page 36.

Basic Operations

Remote Control

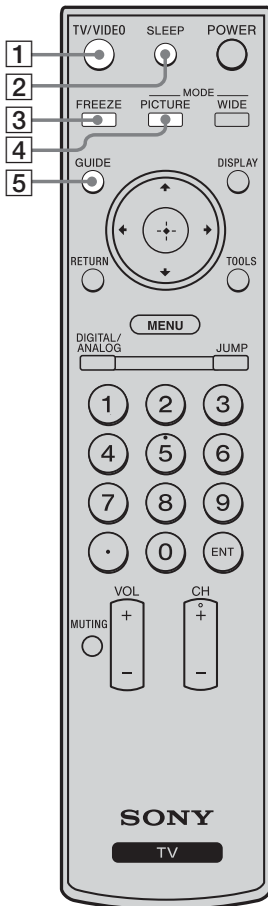

The 5 button and CH + have a tactile dot. Use them as a reference when operating the TV.

Button	Description
1 TV/VIDEO	Press repeatedly to cycle through the video inputs. See page 30 on setting up the video input labels, including the skip function.
2 SLEEP	Press repeatedly until the TV displays the time in minutes (15, 30, 45, 60, 90 or 120) that you want the TV to remain on before shutting off. To cancel Sleep Timer, press SLEEP repeatedly until Sleep Off appears.
3 FREEZE	Press once to display a frozen image of the current program in a window. Press again to show only the frozen image. Press again to return to the program. Current program Frozen picture Move the sub screen with .
4 PICTURE	Press repeatedly to cycle through the available picture modes: Vivid, Standard, Custom. The picture modes can be also accessed in the Picture settings. For details, see "Using the Picture Settings" on page 24.
5 GUIDE	Press to display the Guide when you are watching digital channels (if it is available from the station). Using the Guide The Guide allows you to select the channels from a channel list. The Guide also provides information about the current program being shown on each channel.

With Freeze function active, some functions are unavailable, such as MENU.

Information banner

Channel list

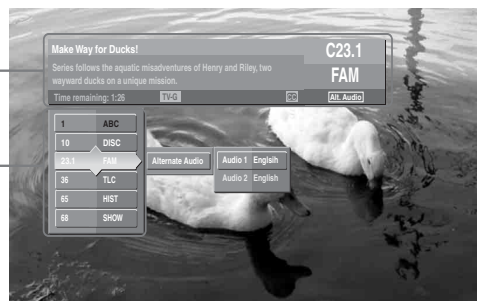

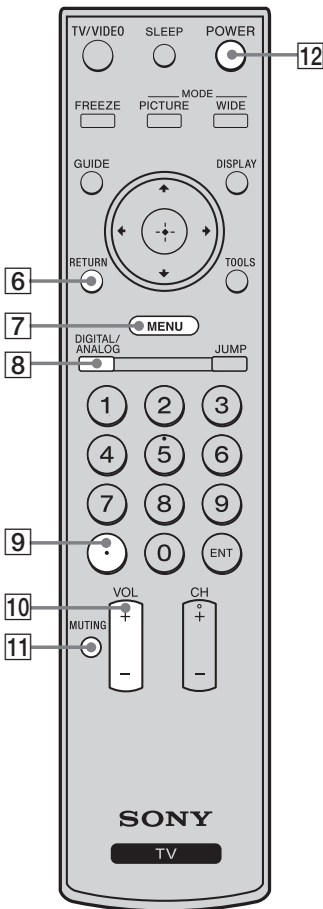

Button	Description
	Program information in the guide is provided by the broadcasters. As a result, it may sometimes include only the channel number, without a program title or description.
Using the Program Options Setting	
The Program Options setting allows you to customize the program settings on the currently tuned channel.	
Alternate Audio (When available)	Each program has a main video and audio stream (the video or audio that you see or hear when the channel is first tuned), and may have alternate streams. This option allows you to switch among the alternate audio stream, when the broadcaster provides an alternate audio stream (for instance, the audio may contain a different language).
6 RETURN	Press to go back to the previous screen when displaying MENU items and settings.
7 MENU	Press to display the MENU with TV functions and settings. See "Overview of MENU" on page 22.
8 DIGITAL/ANALOG	Press to switch between analog and digital channels. To enjoy the digital features of this TV, press DIGITAL/ANALOG.
9	Use with 0-9 and ENT buttons to select digital channels. For example, to enter 2.1, press 2 , , 1 and ENT.
10 VOL +/-	Press to adjust the volume.
11 MUTING	Press to mute the sound. Press again or press VOL + to restore the sound.
12 POWER	Press to turn on and off the TV.

(Continued)

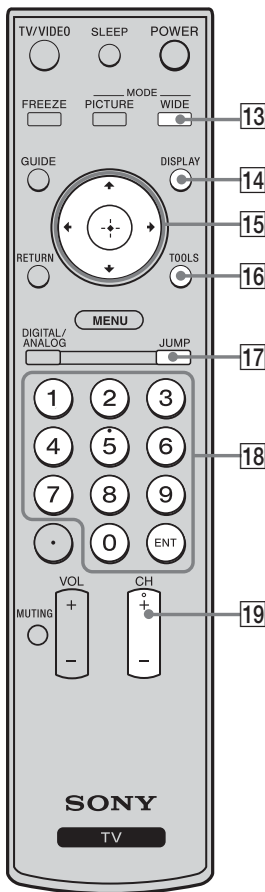

Button	Description												
13 WIDE	Press repeatedly to step through the Wide Mode settings: Wide Zoom, Normal, Full, Zoom. The Wide Mode settings can be also accessed in the Screen settings. See page 27. Changing the Wide Screen Mode (see page 27 for details)												
	<table border="1"> <tr> <td> 4:3 Original source Standard definition source </td> <td> 16:9 Original source High definition source </td> </tr> <tr> <td>↓</td> <td>↓</td> </tr> <tr> <td> Wide Zoom </td> <td> Wide Zoom </td> </tr> <tr> <td> Normal </td> <td> Normal This mode is not available </td> </tr> <tr> <td> Full </td> <td> Full </td> </tr> <tr> <td> Zoom </td> <td> Zoom </td> </tr> </table> <p> When the TV receives a 720p or 1080i signal, Normal cannot be selected.</p>	4:3 Original source Standard definition source 	16:9 Original source High definition source 	↓	↓	Wide Zoom 	Wide Zoom 	Normal 	Normal This mode is not available	Full 	Full 	Zoom 	Zoom
4:3 Original source Standard definition source 	16:9 Original source High definition source 												
↓	↓												
Wide Zoom 	Wide Zoom 												
Normal 	Normal This mode is not available												
Full 	Full 												
Zoom 	Zoom 												
14 DISPLAY	Press once to display the current channel number, channel label, time and Wide Mode settings. The OSD (on screen display) will turn off after a few seconds or press again to immediately turn off the display.												
15	Press to move the on-screen cursor. Press to select/confirm an item.												
16 TOOLS	Press to display the Tools Menu that is associated with your current input: Analog TV, Digital TV, External Inputs, or PC. Each input has a different Tools Menu. (See page 24, 26, 29, 34 and 35.)												
17 JUMP	Press to jump back and forth between two channels. The TV alternates between the current channel and the last channel that was selected.												
18 0 - 9 ENT	Press 0 - 9 to select a channel; the channel changes after two seconds. Press ENT to change channels immediately.												
19 CH +/-	Press to scan through channels. To scan quickly through channels, press and hold down either +/-.												

Insert two size AA batteries (supplied) by matching the and on the batteries to the diagram inside the remote control's battery compartment.

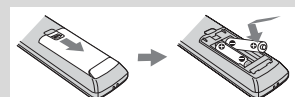

TV Controls

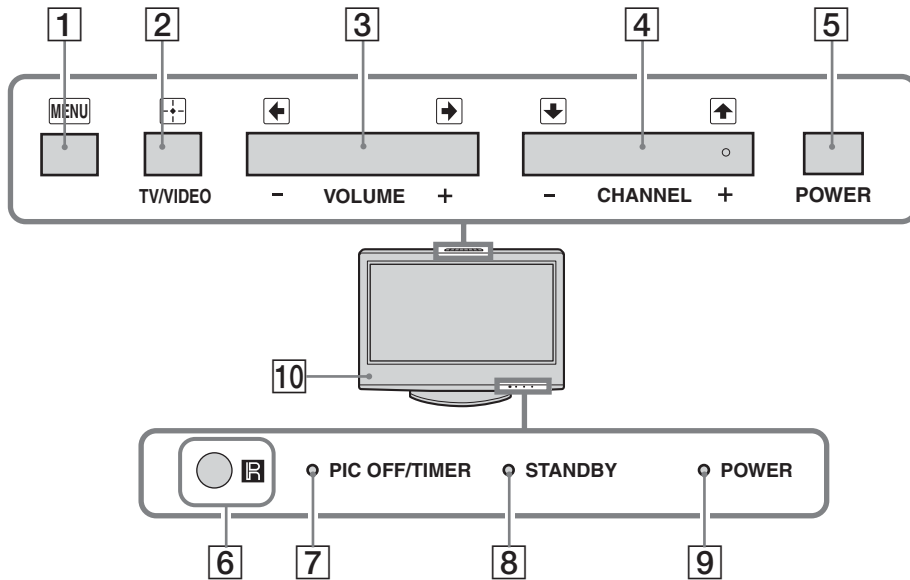

Item	Description
1	MENU Press to display MENU with TV functions and settings (see “Overview of MENU” on page 22).
2	+/- TV/VIDEO Press to cycle through the video inputs. If you set a certain input to Skip in Label Video Inputs, then the input will not appear. In the MENU screen, this button serves as confirming the selection or setting.
3	← → - VOLUME + Press to adjust the volume. In the MENU screen, these buttons serve as left/right buttons.
4	↓ ↑ - CHANNEL + Press to scan through channels. To scan quickly through channels, press and hold down either -/+. In the MENU screen, these buttons serve as up/down buttons.
5	POWER Press to turn on and off the TV.
6	(IR) Infrared Receiver/ Light Sensor Receives IR signals from the remote control. Senses room light level and adjusts the screen brightness accordingly (see page 31 for details). Do not put anything near the sensor, as its function may be affected.
7	PIC OFF/ TIMER LED Lights up in green when the Picture Off feature is activated. Lights up in orange when the timer is set. When the timer is set, this LED will remain lit even if the TV is turned off. For details, see page 30.
8	STANDBY LED Lights up in red when your TV is in PC power saving mode. If the LED blinks in red continuously, this may indicate the display unit needs servicing (see “Contacting Sony” on page 2).
9	POWER LED Lights up in green when the TV is turned on.
10	Speaker Outputs audio signal.

The CHANNEL + button has a tactile dot. Use it as a reference when operating the TV.

Make sure that the TV is completely switched off before unplugging the power cord. Unplugging the power cord while the TV is turned on may cause the LED to remain lit or may cause the TV to malfunction.

Introducing MENU Function

Overview of MENU

MENU provides one button access for controlling your TV. It enables you to perform a variety of tasks intuitively with a control panel on the screen rather than a variety of remote control button presses. When you press the MENU button, you can easily perform basic TV functions such as: switching between external inputs, viewing your favorite analog/digital stations, switching between analog and digital channels, and changing or customizing your TV settings.

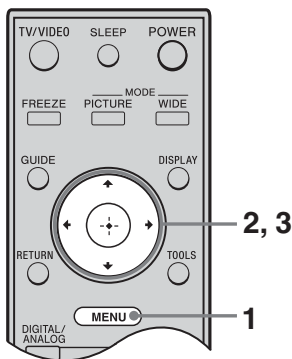

- 1 Press MENU on the remote. MENU control panel appears.
- 2 Press \uparrow/\downarrow to highlight the item.
- 3 Press \oplus to select an option. Press MENU to exit.

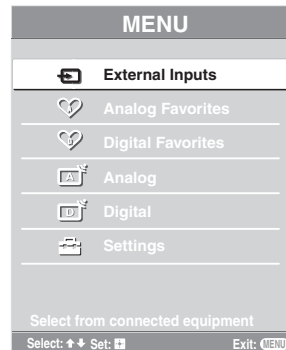

MENU

Allows you to

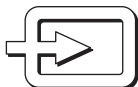

External Inputs

The External Inputs feature lets you select the external inputs connected to your TV. You can also assign a label using Label Video Inputs in the Setup settings. (see page 30)

- 1 Highlight External Inputs on the MENU control panel and press \oplus .
- 2 Press \uparrow/\downarrow to highlight the desired external input and press \oplus .

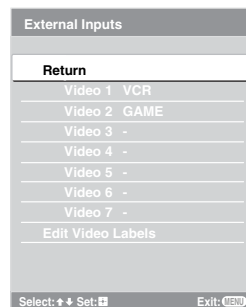

MENU

Allows you to



Analog Favorites

The Analog Favorites feature lets you select programs from a list of up to 16 favorite channels that you specify.

- 1 Highlight Analog Favorites on the MENU control panel and press (+).
- 2 Press ↑/↓ to highlight the desired channel and press (+). To add the current channel to the list of Favorite Channels, highlight Add to Favorites and press (+).

When the Favorite Channels list is full, remove a channel from your list using Favorite Channels in the Analog Setup (see page 35) settings and try again. Favorite Channels can be accessed directly from Edit Favorites.

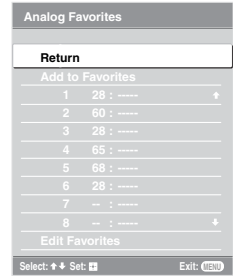

Digital Favorites

The Digital Favorites feature lets you create a list of up to 16 favorite channels. To create your favorite list:

- 1 Highlight Digital Favorites on the MENU control panel and press (+).
- 2 Highlight Add to Favorites and press (+) to add the current channel to the list of Favorite Channels.

When the Favorite Channels list is full, remove a channel from your list using Favorite Channels in the Digital Setup (see page 36) settings and try again. Favorite Channels can be accessed directly from Edit Favorites.



Analog

The Analog feature takes you to the most recently viewed analog channel. When tuned to the channel, Channel number will be displayed. Highlight Analog on the MENU control panel and press (+).



Digital

The Digital feature takes you to the most recently viewed digital channel. When tuned to the channel, the Program Banner and Channel number will be displayed. Highlight Digital on the MENU control panel and press (+).



Settings

The Settings feature lets you enter to the settings screen. Advanced settings and adjustments can be performed from Settings menu. See “Navigating Through Settings” on pages 24.

Navigating Through Settings

The Settings provides access to the features:

- 1 Press **MENU**.
- 2 Select .
- 3 Highlight the item: Picture, Sound, Screen, Setup, PC Settings, Analog Setup, Digital Setup.
- 4 Press **+** to select an option.

To exit the settings, press **MENU**.

 The options you can adjust vary depending on the situation. Unavailable options are grayed out.

Using the Picture Settings

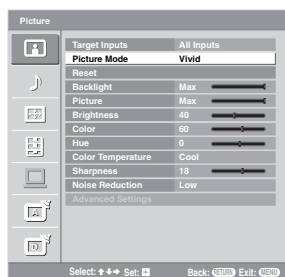



Option	Description
Target Inputs	Determines whether to apply Picture menu settings to all inputs, or only to the input you are currently watching.
	All Inputs Applies settings to all inputs.
	Current Input Applies settings to the current input.
Picture Mode <i>Customized picture viewing</i>	Vivid Select for enhanced picture contrast and sharpness.
	Standard Select for standard picture settings. Recommended for home entertainment.
	Custom Allows you to store your preferred settings.
	 Picture Mode can also be accessed from TOOLS button when in Analog TV, Digital TV and External Inputs.
Reset	Resets the current Picture Mode setting to the default values.
Backlight	Adjust to brighten or darken the backlight.
Picture	Adjust to increase or decrease picture contrast.
Brightness	Adjust to brighten or darken the picture.
Color	Adjust to increase or decrease color intensity.
Hue	Adjust to increase or decrease the green tones.
Color Temperature <i>White adjustment</i>	Cool Select to give the white colors a bluish tint.
	Neutral Select to give the white colors a neutral tint.
	Warm 1,2 Select to give the white colors a reddish tint. Available only when Picture Mode is set to Custom.
Sharpness	Adjust to sharpen or soften the picture.

Option	Description	
Noise Reduction	Select to reduce the noise level of connected equipment, and the VHF/UHF input. Select from Auto, High, Medium, Low and Off.  Auto is only available when you are watching analog channels. It is not available when Target Input is set to All Inputs.	
Advanced Settings <i>Only available in "Custom Picture Mode"</i>	Reset	Resets all the advanced settings to the default settings.
	Black Corrector	Enhances black areas of the picture for stronger contrast.
	Contrast Enhancer	Automatically optimizes the backlight and contrast. This setting is especially effective for dark images, increasing the vibrancy of the picture.
	Gamma	Adjusts the balance between the light and dark areas of the picture.
	Clear White	Emphasizes white and light colors.
	Live Color	Makes colors more vivid.
	MPEG Noise Reduction	Reduces the picture noise in MPEG-compressed video. Useful for Digital TV channels.

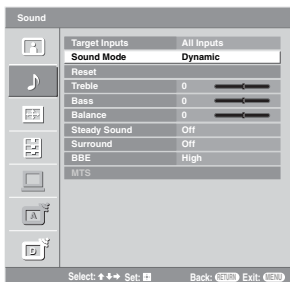
Using the Sound Settings



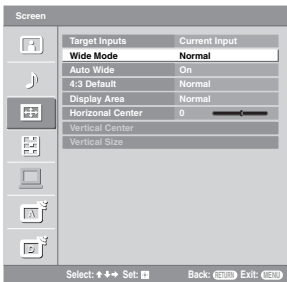

Option	Description
Target Inputs	Determines whether to apply Sound menu settings to all inputs, or only to the input you are currently watching.
	All Inputs Applies settings to all inputs.
	Current Input Applies settings to the current input.
Sound Mode <i>Customized sound listening</i>	Dynamic Select to enhance treble and bass.
	Standard Suitable for spoken dialog.
	Custom Flat setting. Allows you to store your preferred settings.
 Sound Mode can also be accessed from TOOLS button when in Analog TV, Digital TV and External Inputs.	
Reset	Resets the current Sound Mode setting to the default values, except MTS.
Treble	Adjust to increase or decrease higher-pitched sounds.
Bass	Adjust to increase or decrease lower-pitched sounds.
Balance	Adjust to emphasize left or right speaker balance.
Steady Sound	On Select to stabilize the volume across all programs and commercials.
	Off Select to turn off Steady Sound.
Surround	TruSurround XT Select for surround sound (for stereo programs only).
	Simulated Stereo Adds a surround-like effect to mono programs.
	Off Select for normal stereo or mono reception.
BBE	Select to give sound more impact by compensating for phase effects in speakers. Select from High, Low, and Off.
MTS <i>Enjoy stereo, bilingual and mono programs</i>	Stereo Select for stereo reception when viewing a program broadcast in stereo.
	Auto SAP Select to automatically switch the TV to second audio programs when a signal is received. If no SAP signal is present, the TV remains in Stereo mode.
	Mono Select for mono reception. Use to reduce noise during weak stereo broadcasts.
 MTS is only available for analog programs.	

Using the Screen Settings



Introducing MENU Function

Option	Description
Target Inputs	Determines whether to apply Screen menu settings to all inputs, or only to the input you are currently watching.
	All Inputs Applies settings to all inputs.
	Current Input Applies settings to the current input.
Wide Mode	Wide Zoom Select to fill screen with minimum distortion.
	Normal Select to display 4:3 picture in original size when the original source is 4:3.
	 Normal is not available when you are watching 720p or 1080i sources.
	Full Select to enlarge the picture horizontally to fill the screen when the original source is 4:3 (Standard definition source). When the original source is 16:9 (High definition source), select this mode to display 16:9 picture in original size.
	Zoom Select to enlarge the original picture without distorting the aspect ratio.
Auto Wide	On Select to have the screen automatically change to the screen mode that is best for the current program. If frequent screen changes are disturbing to you, select Off.
	Off Select to turn off the Auto Wide option. Choose a screen mode from the Wide Mode option.
4:3 Default <i>Select the default Screen Mode to use for 4:3 sources</i>	Wide Zoom Select to enlarge the 4:3 picture to fill the 16:9 screen, keeping the original image as much as possible.
	Normal Select to display the 4:3 picture in its original size.
	Off Select to continue using the current Wide Mode setting when the channel or input is changed.
	 If 4:3 Default is set to anything but Off, the Wide Mode setting changes only for the current channel. When you change channels (or inputs), Wide Mode is automatically replaced with the 4:3 Default setting for 4:3 sources. To retain the current Wide Mode setting as channels and inputs are changed, set 4:3 Default to Off.
Display Area	Select Normal to return to the default display area. Select -1 or -2 to enlarge the picture so that the edges are outside the visible portion of the screen.

(Continued)

Introducing MENU Function

<i>Option</i>	<i>Description</i>
Horizontal Center	Allows you to move the position of the picture left and right. Press ◀/▶ and press ⊕ to choose a correction between Min, -4 to +4 and Max.  Horizontal Center feature is useful if TV is connected to game equipment.
Vertical Center	Allows you to move the position of the picture up and down. Available only in Zoom mode. Press ▲/▼ and press ⊕ to choose a correction between Min, -4 to +4 and Max.
Vertical Size	Allows you to adjust the vertical size of the picture. (Available only in Wide Zoom and Zoom modes.) Press ▲/▼ and press ⊕ to choose a correction between Min, -4 to +4 and Max.

Using the Setup Settings

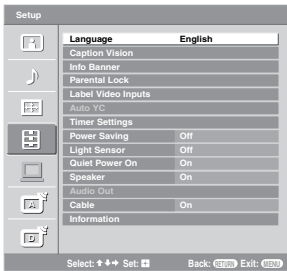









Option	Description
Language	Select to display all on-screen settings in your language of choice: English, Español, Français.
Caption Vision	Allows you to select from several closed caption modes (for programs that are broadcast with closed captioning). Some caption modes for digital channels are only accessible from the Digital Setup setting. For details, see page 37.
	Off Caption Vision is turned off.
	CC1, CC2, CC3, CC4 Displays a printed version of the dialog or sound effects of a program. (Should be set to CC1 for most programs.)
	Text1, Text2, Text3, Text4 Displays network/station information presented using either half or the whole screen (if available).
	 Caption Vision can also be accessed from TOOLS button when in Analog TV and External Inputs.
Info Banner	Set to On or Off. When on, displays the program name and the remaining time (if the broadcaster offers this service). Displays for few seconds when the channel is changed or the DISPLAY button is pressed.
Parental Lock	The Parental Lock settings allows you to set up the TV to block programs according to their content and rating levels. Use 0-9 on the remote control to enter a four-digit password. The first time you create a password, confirm the password by entering it again.
	Lock Off Turn Parental Lock off. No programs are blocked from viewing.
	Child Maximum ratings permitted are: U.S.: TV-Y, TV-G, G Canada: C, G, TV-Y
	Youth Maximum ratings permitted are: U.S.: TV-PG, PG Canada: C8+, PG, 8 ans+, TV-PG
	Young Adult Maximum ratings permitted are: U.S.: TV-14, PG-13 Canada: 14+, 13 ans+, TV-14
	Custom Select to set ratings manually. U.S.: See page 32 for details. Canada: See page 32 for details.

 If you are not familiar with the Parental Guideline rating system, you should select Child, Youth, or Young Adult to help simplify the rating selection. To set more specific ratings, select Custom.

(Continued)

Introducing MENU Function

Option	Description
Change Password	Select to change your password.
	 You need your password for any future access into the Parental Lock settings. If you lose your password, see "Lost password." on page 40.
Select Country	U.S.A. Select to use U.S.A. ratings (see page 32). <hr/> Canada Select to use Canadian ratings (see page 32).
Label Video Inputs	<p>Allows you to identify A/V equipment you connected to the TV, such as a VCR, DVD, etc. For example, if you have a DVD player connected to the VIDEO 4 jack, you can select the label DVD for the Video 4 input. Then when you press TV/VIDEO to change inputs, the Video Label you assigned to that input appears on screen.</p> <ol style="list-style-type: none"> Press ▲/▼ to highlight the video input (Video 1-7) to which you want to assign a label. Then press ⊕ to select the input. Press ▲/▼ to highlight one of the displayed labels. Then press ⊕ to select the label. <p>You can select from the following labels for each input:</p>
Video 1-6	–, RECEIVER, SATELLITE, CABLE BOX, VCR, DVD, DVR, HD, GAME, CAMCORDER, Edit:, Skip
Video 7	–, PC, Edit:, Skip
	 Edit: allows you to create a custom five character label.  If you select Skip, your TV skips this input when you press the TV/VIDEO button.  The Skip label is useful for inputs to which no equipment is connected.
Auto YC	<p>When connecting both VIDEO IN and S VIDEO IN, you can select the jack from which the TV receives the input signal. The TV is default set to receive S VIDEO input signals.</p> <ol style="list-style-type: none"> Press TV/VIDEO repeatedly until the desired video input appears. After selecting the Auto YC option, to watch the pictures input from the S VIDEO input jack: Press ▲/▼ to highlight On, then press ⊕. To watch the pictures input from the VIDEO input jack: Press ▲/▼ to highlight Off, then press ⊕.
Timer Settings	<p>Sleep Timer Set the time in minutes (15 min, 30 min, 45 min, 60 min, 90 min, 120 min, or Off) that you want the TV to remain on before shutting off automatically.</p> <hr/> <p>Timer You can use the Timer to turn the TV on, turn it off, or tune it to a specific channel at a scheduled time.</p> <p>Timer feature will not be available until you set the Current Time.</p> <ol style="list-style-type: none"> Press ▲/▼ to highlight one of the following options, then press ⊕. <p>Set: Select to set the timer by Day, Time, Duration, Channel and Volume Setup.</p> <p>Off: Select to turn off the timer. (Your previous settings are saved.)</p>



Option	Description
	<p>2 If you selected Set in step 1, press ▲/▼/◀/▶ to set the day(s), hour, minute, AM/PM, duration, channel number (VHF/UHF, CATV or Digital), and volume. When Digital is selected, the last digital channel you viewed will automatically show when the TV is turned on.</p> <p>3 Press MENU to exit Settings.</p>
	<p> To return to the Timer Settings after programming the Timer or Current Time, press ←.</p> <p> Timer will be set to Off when:</p> <ul style="list-style-type: none"> - Auto Program for analog channels is executed. - the AC power cord is disconnected and then reconnected to turn the TV on and the Current Time is displayed as --:-- --.
	<p>Current Time Select to set the current time (day, hour, minute, and AM/PM).</p> <p>1 Press ⊕ to select Current Time.</p> <p>2 Press ▲/▼/◀/▶ to set the current time (day, hour, minute, and AM/PM).</p> <p>3 Press MENU to exit Settings.</p>
<p>Power Saving</p>	<p>Select to reduce the power consumption by adjusting the backlight brightness. This also enhances the black level. Select from Off, Low, High and Picture Off.</p>
<p>Light Sensor</p>	<p>Select On to enable the automatic picture (screen) brightness control. The light sensor measures the room brightness which allows the TV to automatically adjust the backlight brightness based on the picture settings and the ambient room light conditions.</p> <p> Be sure not to put anything around the sensor, as its function may be affected. See page 21 on the sensor.</p> <p> In low light the range of the backlight control is reduced when Light Sensor is set to On.</p>
<p>Quiet Power On</p>	<p>Select to have the TV volume start at the minimum volume and gradually change to the set level when you turn it on.</p>
<p>Speaker</p>	<p>On Select to turn on the TV speakers.</p> <p>Off Select to turn off the TV speakers and listen to the TV's sound only through your external audio receiver and speakers.</p>
<p>Audio Out <i>Easy control of volume adjustments</i></p>	<p>Variable When Speaker is set to Off, the audio output from your audio system can be controlled by the TV's remote control.</p> <p>Fixed When Speaker is set to Off, the audio output of the TV is fixed. Use your audio receiver's remote control to adjust the volume (and other audio settings) through your audio system.</p>
<p>Cable</p>	<p>On Select if you are receiving cable channels via Cable TV provider.</p> <p>Off Select if you are using an antenna.</p> <p> You should run Auto Program after changing the Cable setting.</p>
<p>Information</p>	<p>Select to display the equipment information of your TV.</p>

(Continued)

Introducing MENU Function

US Models: Selecting Custom Rating Options

To select custom rating options for the U.S., select U.S.A. in the Select Country setting (see page 30).

Option	Description
Movie Rating	G All children and general audience.
	PG Parental guidance suggested.
	PG-13 Parental guidance for children under 13.
	R Restricted viewing, parental guidance is suggested for children under 17.
	NC-17 and X No one 17 or under allowed.
TV Rating <i>Block programs by their rating, content or both</i>	Age-Based Ratings
	TV-Y All children.
	TV-Y7 Directed to children age 7 and older.
	TV-G General audience.
	TV-PG Parental guidance suggested.
	TV-14 Parents strongly cautioned.
	TV-MA Mature audience only.
	Content-Based Ratings
	FV Fantasy violence.
	D Suggestive dialogue.
	L Strong language.
	S Sexual situations.
	V Violence.
	 To ensure maximum blocking capability, set the Age-Based Ratings.
	Unrated <i>Block programs or movies that are broadcast without a rating</i>
Block Blocks all programs and movies that are broadcast without a rating.	
 If you block unrated TV programs, be aware that the following types of programs may be blocked: programs broadcast from another country, emergency broadcasts, political programs, sports, news, public service announcements, religious programs and weather.	

Canadian Models: Selecting Custom Rating Options

To select custom rating options for Canada, select Canada in the Select Country setting (see page 30).

Option	Description
English Rating	C All children.
	C8+ Children 8 years and older.
	G General programming.
	PG Parental guidance.
	14+ Viewers 14 and older.
	18+ Adult programming.





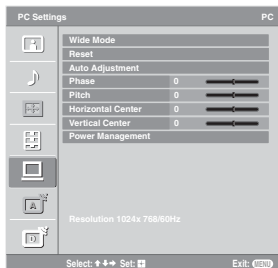

<i>Option</i>	<i>Description</i>	
French Rating	G	General programming.
	8 ans+	Not recommended for young children.
	13 ans+	Not recommended for ages under 13.
	16 ans+	Not recommended for ages under 16.
	18 ans+	Programming restricted to adults.
U.S.A. Rating	See "US Models" on page 32 for details.	

Viewing Blocked Programs

You can view blocked programs by entering the password. Press ENT when tuned to a blocked program, then enter the password. This temporarily turns the parental control feature off. To reactivate the Parental Lock settings, turn off the TV. When the TV is turned on again, your Parental Lock settings are reactivated.



Using the PC Settings

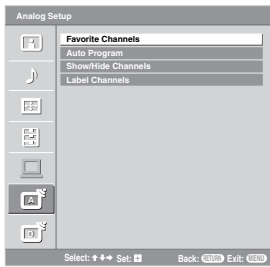

Option	Description
Wide Mode	Normal Select to display in the original image size.
	Full1 Select to enlarge the picture to fill the display area, keeping its original horizontal-to-vertical ratio.
	Full2 Select to enlarge the picture to fill the display area.
Reset	Resets the current setting to its default setting.
Auto Adjustment	Select to automatically adjust the display position and phase of the picture when the TV receives an input signal from the connected PC. Note that Auto Adjustment may not work well with certain input signals. In such cases, manually adjust the options below.  Auto Adjustment for PC can also be set from TOOLS button.
Phase	Adjust after Pitch to fine tune overall sharpness.
Pitch	Adjust uneven sharpness on screen.  For the PC Input Signal Reference Chart, see page 41.
Horizontal Center	Allows you to move the position of the picture left and right. Press  and press  to choose a correction between Min, -49 to +49 and Max.
Vertical Center	Allows you to move the position of the picture up and down. Press  and press  to choose a correction between Min, -49 to +49 and Max.
Power Management	On Select to automatically switch to the power saving mode when there is no signal input for 30 seconds.
	Off Select to turn off Power Management.  Power Management is not VESA-compliant.

Using the Analog Setup Settings







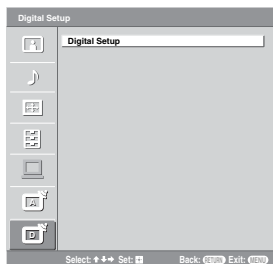





Option	Description
Favorite Channels	<p>Lets you set up a list of up to 16 of your favorite channels.</p> <ol style="list-style-type: none"> 1 Press ▲/▼ to highlight a Favorite Channel number (1-16) which you want to make your Favorite Channel, then press (+) to select it. 2 Press ▲/▼ to scroll through the channels until you find the channel that you would like to edit and then press (+) to select it. To select other Favorite Channel numbers, repeat steps 1-2. <p> To select Favorite Channel numbers that you specified, see page 23.</p> <p> Favorite Channels for Analog TV can also be set from TOOLS button.</p>
Auto Program	Automatically sets up the channel list on the TV for all receivable channels.
Show/Hide Channels	<p>Allows you to show or hide channels that appear when you use the CH +/- buttons.</p> <ol style="list-style-type: none"> 1 Press ▲/▼ to scroll through the channels until you find the channel you want to show or hide. Then press (+) to select it. 2 Press ▲/▼ to determine if the channel will be shown or hidden. To show or hide more channels, repeat steps 1-2. <p> Channels that you set to be hidden can be accessed only with the 0-9 buttons.</p>
Label Channels	<p>Allows you to assign labels (such as station call letters) to channel numbers.</p> <ol style="list-style-type: none"> 1 Press ▲/▼ to scroll through the channel numbers. Then press (+) to select the channel number that you want to assign a label. 2 Press ▲/▼ to scroll through the label characters (A-Z, 0-9, etc.). Press ▶ to move to the next character. Repeat to add up to 5 characters to the label. Press ▶ to highlight OK and press (+) to set. To assign labels to more channels, repeat steps 1-2.

Using the Digital Setup Settings



Highlight Digital Setup and press . The Digital Setup option appears.

Option	Description
Digital Channels	<p>Favorite Channels Lets you set up a list of up to 16 of your favorite channels.</p> <ol style="list-style-type: none"> 1 Press  to highlight a Favorite Channel number (1-16) which you want to make your Favorite Channel. 2 Enter the number you wish to assign to the channel. Reset will remove the existing Favorite Channel and Surf will take you to the Favorite Channel list. <p>To select other Favorite Channel numbers, repeat steps 1-2.</p>
Digital Channels	<p>Add Select to add digital channels.</p>
Auto Program	Automatically sets up the channel list on the TV for all receivable digital channels.
Show/Hide Channels	<p>Allows you to show or hide channels that appear when you use the CH +/- buttons.</p> <ol style="list-style-type: none"> 1 Press  to scroll through the channels until you find the channel you want to show or hide. 2 Press  to determine if the channel will be shown or hidden. <p>To show or hide more channels, repeat steps 1-2.</p>
<p> Channels that you set to be hidden can be accessed only with the 0-9 buttons.</p>	
Label Channels	<p>Allows you to assign labels (such as station call letters) to channel numbers.</p> <ol style="list-style-type: none"> 1 Press  to scroll through the channel numbers. Then press  to select the channel number that you want to assign a label. 2 Press  to scroll through the label characters (A-Z, 0-9, etc.). Press  to move to the next character. Repeat to add up to 7 characters to the label. Then press  to set it. <p>To assign labels to more channels, repeat steps 1-2.</p>

Option	Description		
Digital Setup	Caption Vision	Allows you to select from several closed-caption modes for digital channels. To set Caption Vision for analog channels, see page 29.	
	On	Caption Vision is turned on.	
	Off	Caption Vision is turned off.	
	Program	Allows you to set basic and advanced Caption Vision options. See “Programming Caption Vision” below.	
	A/V Sync	Off/1/2/3 Use this option to make adjustments to audio and video synchronization when you have external equipment connected to OPTICAL OUT of the TV. Select Off (default setting) to make no adjustments. Select 1 , 2 or 3 to adjust so that the video and audio from your connected external equipment are synchronized with the video.	
	Diagnostics	Display diagnostics information about the TV. This can be useful in providing information to an authorized technician or repair person.	
Parental Lock	The Parental Lock option in the Digital Setup settings allows you to set up the TV to block digital programs that contain digital ratings.		
	 This setting is only available if digital ratings have been downloaded by your TV and ratings have been set for U.S.A. in the Setup settings (see page 29).		
	Password	If the password has not been set, or to change the password, use Change Password option in the Setup settings (see page 30).	
	Digital Rating	Off	Turn Parental Lock off. No programs that contain downloadable ratings are blocked from viewing.
		Custom...	Select to block programs based on downloadable ratings.
		Clear All	Select to clear the entire downloadable rating system.
 This action will delete the current Digital Rating menu and the menu will no longer be available until the TV is tuned to a channel that contains downloadable ratings.			

Programming Caption Vision

If you selected the **Program** option under **Caption Vision**, you can change the following settings:

Option	Description	
Basic	Allows you to select basic analog (EIA-608) closed caption options.	
	CC1, CC2, CC3, CC4	See Caption Vision in the Setup setting on page 29.
	Text1, Text2, Text3, Text4	See Caption Vision in the Setup setting on page 29.
Digital CC	Allows you to set digital closed captioning to Basic (digital EIA-608) or Advanced (digital EIA-708).	
Advanced	Allows you to select advanced digital (EIA-708) closed caption options. Select from the available options.	

(Continued)

Introducing MENU Function

<i>Option</i>	<i>Description</i>
Advanced Settings	Allows you to make additional settings for digital (EIA-708) closed caption options. Select from As Broadcast, Small Text, Large Text and Custom.
Custom...	Allows you to customize the following settings:
Character Size	Small, Standard, Large
Character Style	Style 1-7
Character Color	Color 1-8
Character Opacity	Solid, Translucent
Edge Color	Color 1-8
Edge Type	None, Raised, Depressed, Outline, Left Shadow, Right Shadow
Background Color	None, Color 1-8
Background Opacity	Solid, Translucent
Window Color	None, Color 1-8
Window Opacity	Solid, Translucent

Other Information

Troubleshooting

Problem	Possible Remedies
No picture.	
No picture.	<input type="checkbox"/> Check Power Saving settings (page 31).
Cannot receive any channels.	<input type="checkbox"/> Make sure the power cord is connected securely. <input type="checkbox"/> Turn on the power of the TV. <input type="checkbox"/> Check antenna/cable connections.
TV is locked to one channel.	<input type="checkbox"/> Perform Auto Program to add receivable channels that are not presently in the TV's memory (pages 35 and 36).
Cannot receive or select channels.	<input type="checkbox"/> Perform Auto Program to add receivable channels that are not presently in the TV's memory (pages 35 and 36). <input type="checkbox"/> To receive or select cable channels, make sure that Cable in the Setup settings is set to On (page 31). To receive or select UHF channels over an antenna, make sure Cable is set to Off .
The TV turns off automatically.	<input type="checkbox"/> Check if the Sleep Timer is activated, or confirm the Duration setting of Timer . (page 30). <input type="checkbox"/> Check Power Management in the PC Settings . (page 34)
No picture from some video sources.	<input type="checkbox"/> Check the connection between the optional video equipment and the TV. <input type="checkbox"/> Press TV/VIDEO on the remote control (page 18). <input type="checkbox"/> If you connect video equipment to the S VIDEO input of the TV, set Auto YC to On in the Setup settings (page 30). <input type="checkbox"/> Press MENU on the remote control. Select your desired input from the External Inputs list.
Poor picture.	
Double images or ghosts.	<input type="checkbox"/> Check antenna/cable connections. <input type="checkbox"/> Check the antenna location and direction.
Only snow and noise appear on the screen.	<input type="checkbox"/> Check if the antenna is broken or bent. <input type="checkbox"/> Check if the antenna has reached the end of its serviceable life. (3-5 years in normal use, 1-2 years at the seaside.)
Dotted lines or stripes.	<input type="checkbox"/> Keep the TV away from noise sources such as cars, motorcycles, or hair-dryers.
No color/Dark picture/Color is not correct/The picture is too bright.	<input type="checkbox"/> Press PICTURE to select the desired picture mode (page 18). <input type="checkbox"/> Adjust the Picture Mode options in the Picture settings (page 24). <input type="checkbox"/> If you set the Power Saving mode to Low or High , it will enhance the black level.
Noisy picture.	<input type="checkbox"/> Make sure that the antenna is connected using the supplied 75-ohm coaxial cable. <input type="checkbox"/> Keep the antenna cable away from other connecting cords. <input type="checkbox"/> To avoid TV interference, make sure to use an undamaged antenna cable.
No sound/Noisy sound	
Good picture, no sound.	<input type="checkbox"/> Check the volume control. <input type="checkbox"/> Press MUTING or VOL + so that "Muting" disappears from the screen (page 19). <input type="checkbox"/> Disconnect your headphones. <input type="checkbox"/> Set Speaker to On in the Setup settings (page 31). If it is set to Off , sound is not output from the TV's speakers regardless of the TV's volume control.





(Continued)

Other Information

Problem	Possible Remedies
Audio noise.	<ul style="list-style-type: none"><input type="checkbox"/> Make sure that the antenna is connected using the supplied 75-ohm coaxial cable.<input type="checkbox"/> Keep the antenna cable away from other connecting cords.<input type="checkbox"/> To avoid TV interference, make sure to use an undamaged antenna cable.
Wide Mode changes automatically.	<ul style="list-style-type: none"><input type="checkbox"/> The current Wide Mode setting is automatically replaced with the 4:3 Default setting when you change the channel or video input, if 4:3 Default in the Screen settings is set to other than Off. If you want to lock in the Wide Mode selected with the WIDE button, set 4:3 Default to Off in the Screen settings (page 27).<input type="checkbox"/> Check the Auto Wide option in the Screen settings (page 27).
“Black box” on screen.	<ul style="list-style-type: none"><input type="checkbox"/> You have selected a text option in the Setup/Digital Setup setting and no text is available. (See pages 29 and 37 to reset Setup selections.) To turn off this feature, set the Caption Vision option to Off. If you were trying to select closed captioning, select CC1 instead of Text1-4.
Black bands appear at the top and bottom of the screen.	<ul style="list-style-type: none"><input type="checkbox"/> Some wide-screen programs are filmed in aspect ratios that are greater than 16:9 (this is especially common with theatrical releases). Your TV will show these programs with black bands at the top and bottom of the screen. For more details, check the documentation that came with your DVD (or contact your program provider).
Certain programs on DVD or other digital sources display a loss of detail, especially during fast-motion or dark scenes.	<ul style="list-style-type: none"><input type="checkbox"/> The compression used by certain digital broadcasts and DVDs may cause your TV's screen to display less detail than usual, or cause artifacts (small blocks or dots, pixelations) to appear on your screen. This is due to your TV's large screen and ability to show very fine detail, and is normal for certain digitally recorded programs.
Remote control does not operate.	<ul style="list-style-type: none"><input type="checkbox"/> Check the polarity of the batteries or replace the batteries.<input type="checkbox"/> Point the remote control at the remote control sensor of the TV.<input type="checkbox"/> Florescent lamps can interfere with your remote control operation; try turning off the florescent lamps.<input type="checkbox"/> Keep the remote control sensor area clear from obstacles.
Some digital cable channels are not being displayed.	<ul style="list-style-type: none"><input type="checkbox"/> Certain cable companies have limitations on the broadcast of digital cable channels. Check with your cable company for more information.<input type="checkbox"/> The digital cable channel may be set to Hidden in the Show/Hide Channels setting (see page 36).
Lost password.	<ul style="list-style-type: none"><input type="checkbox"/> Select the Parental Lock settings on the settings screen, then enter the following master password: 4357. The master password clears your previous password and allows you to enter a new password (page 30).
How to reset the TV to factory settings.	<ul style="list-style-type: none"><input type="checkbox"/> Turn on the TV. While holding down the ▲ button on the remote control, press the POWER button on the TV. (The TV will turn itself off, then back on again.) Release the ▲ button. WARNING: The Reset will clear all of your customized settings including Parental Lock setting.

PC Input Signal Reference Chart

Resolution Signals	Horizontal (Pixel)	×	Vertical (Line)	Horizontal frequency (kHz)	Vertical frequency (Hz)	Standard
VGA	640	×	480	31.5	60	VGA
	640	×	480	37.5	75	VESA
	720	×	400	31.5	70	VGA-T
SVGA	800	×	600	37.9	60	VESA Guidelines
	800	×	600	46.9	75	VESA
XGA	1024	×	768	48.4	60	VESA Guidelines
	1024	×	768	56.5	70	VESA
	1024	×	768	60.0	75	VESA
WXGA	1280	×	768	47.4	60	VESA
	1280	×	768	47.8	60	VESA
	1360	×	768	47.7	60	VESA

-  This TV's PC Input does not support Sync on Green or Composite Sync.
-  This TV's PC Input does not support interlaced signals.
-  This TV's PC Input supports signals in the above chart with a 60Hz vertical frequency.
-  For the best picture quality, it is recommended to use signals with a 60Hz vertical frequency from a personal computer. In plug and play, signals with 60Hz vertical frequency will be selected automatically.

Other Information

Specifications

Television system:

NTSC American TV Standard
ATSC (8VSB terrestrial) ATSC compliant 8VSB
QAM on cable ANSI/SCTE 07 2000
(Does not include CableCARD functionality)

Channel coverage:

Terrestrial (analog) 2-69
Cable TV (analog) 1-125
Terrestrial (digital) 2-69
Cable TV (digital) 1-135

Antenna:

75-ohm external terminal for VHF/UHF

Screen size (measured diagonally):

KDL-26S2000: 26 inches
KDL-32S2000: 32 inches
KDL-40S2000: 40 inches

Panel System:

LCD (Liquid Crystal Display) Panel

Display resolution (horizontal × vertical):

1,366 dots × 768 lines

VIDEO IN 1/2/3:

S VIDEO (4-pin mini DIN) (VIDEO 1/2 only):
Y: 1.0 Vp-p, 75 ohms unbalanced, sync negative
C: 0.286 Vp-p (Burst signal), 75 ohms
VIDEO: 1 Vp-p, 75 ohms unbalanced, sync negative
AUDIO: 500 mVrms (100% modulation)
Impedance: 47 kilohms

HD/DVD IN 4/5:

YPbPr (Component Video):
Y: 1.0 Vp-p, 75 ohms unbalanced, sync negative
PB: 0.7 Vp-p, 75 ohms
PR: 0.7 Vp-p, 75 ohms
Signal format: 480i, 480p, 720p, 1080i
AUDIO: 500 mVrms (100% modulation)
Impedance: 47 kilohms

HDMI IN 6:

HDMI: Video: 480i, 480p, 720p, 1080i
Audio: Two channel linear PCM 32, 44.1 and 48 kHz, 16, 20 and 24 bits
AUDIO: 500 mVrms (100% modulation)
Impedance: 47 kilohms

AUDIO OUT:

500 mVrms (100% modulation)
More than 1 Vrms at the maximum volume setting (Variable)
More than 500 mVrms (Fixed)

PC IN 7:

D-sub 15-pin, analog RGB, 0.7 Vp-p, 75 ohms, positive
See the PC Input Signal Reference Chart on page 41

PC AUDIO INPUT:

Stereo mini jack, 0.5 Vrms, 1 kilohm

Headphones:

Stereo mini jack
Impedance: 16 ohms

Speaker:

Full range: KDL-26S2000: 42 × 150 mm (1¹¹/₁₆ × 6 inches) (2)
KDL-32S2000: 42 × 150 mm (1¹¹/₁₆ × 6 inches) (2)
KDL-40S2000: 55 × 150 mm (2¹/₄ × 6 inches) (2)

Speaker output:

10 W + 10 W

Power requirement:

120 V-240 V AC, 50/60 Hz

Power consumption:

In use: KDL-26S2000: 120W
KDL-32S2000: 150W
KDL-40S2000: 200W

In standby: Less than 0.1 W

Dimensions (W/H/D):

KDL-26S2000: (with stand) 658 × 516 × 219 mm
(26 × 20³/₈ × 8⁵/₈ inches)
(without stand) 658 × 470 × 94 mm
(26 × 18⁵/₈ × 3³/₄ inches)
KDL-32S2000: (with stand) 792 × 593 × 219 mm
(31¹/₄ × 23³/₈ × 8⁵/₈ inches)
(without stand) 792 × 546 × 99 mm
(31¹/₄ × 21¹/₂ × 4 inches)
KDL-40S2000: (with stand) 988 × 716 × 334 mm
(39 × 28¹/₄ × 13¹/₄ inches)
(without stand) 988 × 664 × 103 mm
(39 × 26¹/₄ × 4¹/₈ inches)

Mass:

KDL-26S2000: (with stand) 13 kg (28 lb. 10 oz.)
(without stand) 11 kg (24 lb. 4 oz.)
KDL-32S2000: (with stand) 17 kg (37 lb. 7 oz.)
(without stand) 15 kg (33 lb.)
KDL-40S2000: (with stand) 27 kg (59 lb. 8 oz.)
(without stand) 21 kg (46 lb. 3 oz.)

Supplied accessories:

Remote control RM-YD005 (1)
Size AA batteries (2)
75-ohm coaxial cable (1)
AC power cord (1)
HD15-HD15 cable (1)
Support belt (1), securing screw (1) and wood screw (1)
Cable holder (1)
Operating Instructions (1)
Quick Setup Guide (1)
Leaflet (Installing the Wall-Mount Bracket) (1)
Warranty Card (1)
Online Registration Card (U.S.A. only) (1)

Optional accessories:

Headphones plug adapter
Connecting cables
Wall-Mount Bracket: SU-WL31 (KDL-26S2000/KDL-32S2000)
SU-WL51 (KDL-40S2000)

 Optional accessories' availability depends on its stock.

Design and specifications are subject to change without notice.

4:3 Default 27

A

A/V Sync 37
AC IN 14
Advanced Settings 25
Alternate Audio 19
Audio Out 31
AUDIO OUT jack, described 14
Auto Adjustment 34
Auto Program 17, 35, 36
Auto SAP, MTS setting 26
Auto Wide 27
Auto YC 30

B

Backlight 24
Balance 26
Bass 26
BBE 26
Bilingual audio 26
Brightness 24

C

Cable
 with VCR, connecting 12
Caption Vision 29, 37
CH+/- button 20, 21
Channels
 Creating labels 35, 36
 Setting up 17
Closed caption modes 29
Color 24
Color Temperature 24
Current Time 31

D

Diagnostics 37
Digital Channels 36
Digital Setup 37
DIGITAL/ANALOG button 19
Display Area 27
DISPLAY button 20
Dynamic, Sound Mode 26

E

English Rating 32
ENT button 20

F

Favorite Channels 35, 36
FREEZE button 18
French Rating 33

G

GUIDE button 18

H

HD/DVD IN jack (1080i/720p/480p/480i), described 14
HDMI IN jack, described 14
Headphones jack, described 13

Horizontal Center 28, 34
Hue 24

I

Info Banner 29
Information 31
Infrared Receiver (IR) 21

J, K

JUMP button 20

L

Label Channels 35, 36
Label Video Inputs 30
Language 29
Light Sensor
 Described 21
 Setting 31

M

MENU
 Analog 23
 Analog Favorites 23
 Digital 23
 Digital Favorites 23
 External Inputs 22
 Settings 23
MENU button 19, 21
Mono, MTS setting 26
Movie Rating 32
MTS 26
MUTING button 19

N

Noise Reduction 25

O

OPTICAL OUT 14

P, Q

Parental Lock 29, 37
PC IN 13
Phase 34
PIC OFF LED 21
Picture 24
PICTURE button 18
Picture Mode 24
Pitch 34
POWER button 19, 21
POWER LED 21
Power Management 34
Power Saving 31
Problems, troubleshooting 39, 40
Program Options 19
Quiet Power On 31

R

Reset 24, 26, 34, 40
RETURN button 19

S

S VIDEO jack, described 13, 14

Setting up channels 17
Settings

 Analog Setup 35
 Digital Setup 36
 PC 34
 Picture 24
 Screen 27
 Setup 29
 Sound 26
Sharpness 24
Show/Hide Channels 35, 36
SLEEP button 18
Sound Mode 26
Speaker 31
STANDBY LED 21
Steady Sound 26
Stereo, MTS setting 26
Support Belt 15
Surround 26
Swivel 16

T, U

Target Inputs 24, 26, 27
TIMER LED 21
Timer Settings 30
TOOLS button 20
Treble 26
Troubleshooting 39, 40
TruSurround XT 26
Turning on/off the TV 21
TV Rating 32
TV/VIDEO button 18
Unrated 32
US Models 32

V

VCR
 With cable, connecting 12
Vertical Center 28, 34
Vertical Size 28
VHF/UHF input, described 14
VIDEO/AUDIO (L/R) jacks, described 13, 14
Viewing Blocked Programs 33
VOL+/- button 19, 21

W, X, Y

WIDE button 20
Wide Mode 27, 34

HDTV
HIGH-DEFINITION TELEVISION

BBE
DIGITAL[®]

DD **DOLBY**
DIGITAL

SRS [®]
TruSurround XT

<http://www.sony.net/>



Printed on 100% recycled paper.

Printed in Japan



Free Manuals Download Website

<http://myh66.com>

<http://usermanuals.us>

<http://www.somanuals.com>

<http://www.4manuals.cc>

<http://www.manual-lib.com>

<http://www.404manual.com>

<http://www.luxmanual.com>

<http://aubethermostatmanual.com>

Golf course search by state

<http://golfingnear.com>

Email search by domain

<http://emailbydomain.com>

Auto manuals search

<http://auto.somanuals.com>

TV manuals search

<http://tv.somanuals.com>