

LCD Monitor

Operating Instructions

HDMI[™]
HIGH-DEFINITION MULTIMEDIA INTERFACE

LMD-940W

Owner's Record

The model and serial numbers are located at the rear. Record these numbers in the spaces provided below. Refer to these numbers whenever you call upon your Sony dealer regarding this product.

Model No. _____

Serial No. _____

Important Safety Instructions

- Read these instructions.
- Keep these instructions.
- Heed all warnings.
- Follow all instructions.
- Do not use this apparatus near water.
- Clean only with dry cloth.
- Do not block any ventilation openings. Install in accordance with the manufacturer's instructions.
- Do not install near any heat sources such as radiators, heat registers, stoves, or other apparatus (including amplifiers) that produce heat.
- Do not defeat the safety purpose of the polarized or grounding-type plug. A polarized plug has two blades with one wider than the other. A grounding-type plug has two blades and a third grounding prong. The wide blade or the third prong are provided for your safety. If the provided plug does not fit into your outlet, consult an electrician for replacement of the obsolete outlet.
- Protect the power cord from being walked on or pinched particularly at plugs, convenience receptacles, and the point where they exit from the apparatus.
- Only use attachments/accessories specified by the manufacturer.
- Use only with the cart, stand, tripod, bracket, or table specified by the manufacturer, or sold with the apparatus.  When a cart is used, use caution when moving the cart/apparatus combination to avoid injury from tip-over.
- Unplug this apparatus during lightning storms or when unused for long periods of time.
- Refer all servicing to qualified service personnel. Servicing is required when the apparatus has been damaged in any way, such as power-supply cord or plug is damaged, liquid has been spilled or objects have fallen into the apparatus, the apparatus has been exposed to rain or moisture, does not operate normally, or has been dropped.

WARNING

To reduce the risk of fire or electric shock, do not expose this apparatus to rain or moisture.

To avoid electrical shock, do not open the cabinet. Refer servicing to qualified personnel only.

WARNING
THIS APPARATUS MUST BE EARTHED.

WARNING

When installing the unit, incorporate a readily accessible disconnect device in the fixed wiring, or connect the power plug to an easily accessible socket-outlet near the unit. If a fault should occur during operation of the unit, operate the disconnect device to switch the power supply off, or disconnect the power plug.

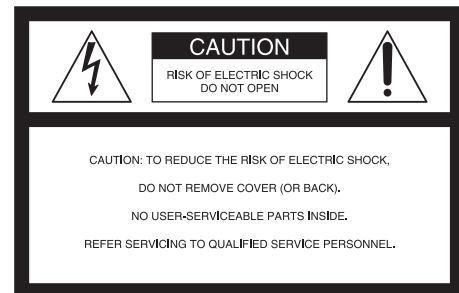

This symbol is intended to alert the user to the presence of uninsulated “dangerous voltage” within the product’s enclosure that may be of sufficient magnitude to constitute a risk of electric shock to persons.



This symbol is intended to alert the user to the presence of important operating and maintenance (servicing) instructions in the literature accompanying the appliance.

Attention-when the product is installed in Rack:

1. Prevention against overloading of branch circuit

When this product is installed in a rack and is supplied power from an outlet on the rack, please make sure that the rack does not overload the supply circuit.

2. Providing protective earth

When this product is installed in a rack and is supplied power from an outlet on the rack, please confirm that the outlet is provided with a suitable protective earth connection.

3. Internal air ambient temperature of the rack

When this product is installed in a rack, please make sure that the internal air ambient temperature of the rack is within the specified limit of this product.

4. Prevention against achieving hazardous condition due to uneven mechanical loading

When this product is installed in a rack, please make sure that the rack does not achieve hazardous condition due to uneven mechanical loading.

5. Install the equipment while taking the operating temperature of the equipment into consideration

For the operating temperature of the equipment, refer to the specifications of the Operation Manual.

6. When performing the installation, keep the following space away from walls in order to obtain proper exhaust and radiation of heat.

Upper : 4.4 cm (1 3/4 inches) or more
Lower (when not using the stand) : 1.7 cm (11/16 inches) or more
Rear : 10.0 cm (4 inches) or more

CAUTION

The apparatus shall not be exposed to dripping or splashing. No objects filled with liquids, such as vases, shall be placed on the apparatus.

WARNING

Excessive sound pressure from earphones and headphones can cause hearing loss. In order to use this product safely, avoid prolonged listening at excessive sound pressure levels.

For kundene i Norge

Dette utstyret kan kobles til et IT-strømfordelingssystem.

For the customers in the U.S.A.

This equipment has been tested and found to comply with the limits for a Class A digital device, pursuant to Part 15 of the FCC Rules. These limits are designed to provide reasonable protection against harmful interference when the equipment is operated in a commercial environment. This equipment generates, uses, and can radiate radio frequency energy and, if not installed and used in accordance with the instruction manual, may cause harmful interference to radio communications. Operation of this equipment in a residential area is likely to cause harmful interference in which case the user will be required to correct the interference at his own expense.

You are cautioned that any changes or modifications not expressly approved in this manual could void your authority to operate this equipment.

All interface cables used to connect peripherals must be shielded in order to comply with the limits for a digital device pursuant to Subpart B of Part 15 of FCC Rules.

This device complies with Part 15 of the FCC Rules. Operation is subject to the following two conditions: (1) this device may not cause harmful interference, and (2) this device must accept any interference received, including interference that may cause undesired operation.

WARNING:

Using this unit at a voltage other than 120 V may require the use of a different line cord or attachment plug, or both. To reduce the risk of fire or electric shock, refer servicing to qualified service personnel.

For the customers in Canada

This Class A digital apparatus complies with Canadian ICES-003.

For the customers in Europe

This product with the CE marking complies with both the EMC Directive and the Low Voltage Directive issued by the Commission of the European Community. Compliance with these directives implies conformity to the following European standards:

- EN60065 : Product Safety
- EN55103-1 : Electromagnetic Interference (Emission)
- EN55103-2 : Electromagnetic Susceptibility (Immunity)

This product is intended for use in the following Electromagnetic Environments:

E1 (residential), E2 (commercial and light industrial), E3 (urban outdoors), E4 (controlled EMC environment, ex. TV studio).

For the customers in Europe

The manufacturer of this product is Sony Corporation, 1-7-1 Konan, Minato-ku, Tokyo, Japan. The Authorized Representative for EMC and product safety is Sony Deutschland GmbH, Hedelfinger Strasse 61, 70327 Stuttgart, Germany. For any service or guarantee matters please refer to the addresses given in separate service or guarantee documents.

For the customers in the USA

Lamp in this product contains mercury. Disposal of these materials may be regulated due to environmental considerations. For disposal or recycling information, please contact your local authorities or the Electronic Industries Alliance (www.eiae.org).

Table of Contents

Precaution	5
On Safety	5
On Installation	5
Handling the LCD Screen	5
About the Fluorescent Tube	5
On Cleaning	5
On Repacking	6
On Mounting on a Rack	6
On Fan Error	6
On AC Adaptor Terminal	6
Features	6
Location and Function of Parts and Controls	8
Front Panel	8
Input Signals and Adjustable/Setting Items	10
Rear/Bottom Panel	11
Installing to the Rack (Using MB-531)	12
Power Supply	13
Attaching the AC Adaptor	13
Connecting the AC Power Cord	13
Selecting the Default Settings	14
Selecting the Menu Language	15
Using the Menu	16
Adjustment Using the Menus	18
Items	18
Adjusting and Changing the Settings	18
STATUS menu.....	18
COLOR TEMP/SPACE menu.....	18
USER CONTROL menu.....	19
USER CONFIG menu.....	20
REMOTE menu	24
KEY INHIBIT menu.....	25
Troubleshooting	26
Specifications	26
Dimensions	29

Precaution

On Safety

- Operate the unit only with a power source as specified in the “Specifications” section.
- A nameplate indicating operating voltage, etc., is located on the bottom.
- Should any solid object or liquid fall into the cabinet, unplug the unit and have it checked by qualified personnel before operating it any further.
- Do not drop or place heavy objects on the power cord. If the power cord is damaged, turn off the power immediately. It is dangerous to use the unit with a damaged power cord.
- Unplug the unit from the wall outlet if it is not to be used for several days or more.
- Disconnect the power cord from the AC outlet by grasping the plug, not by pulling the cord.
- The socket-outlet shall be installed near the equipment and shall be easily accessible.

On Installation

- Allow adequate air circulation to prevent internal heat build-up.
Do not place the unit on surfaces (rugs, blankets, etc.) or near materials (curtains, draperies) that may block the ventilation holes.
- Do not install the unit in a location near heat sources such as radiators or air ducts, or in a place subject to direct sunlight, excessive dust, mechanical vibration or shock.

Handling the LCD Screen

- The LCD panel fitted to this unit is manufactured with high precision technology, giving a functioning pixel ratio of at least 99.99%. Thus a very small proportion of pixels may be “stuck”, either always off (black), always on (red, green, or blue), or flashing. In addition, over a long period of use, because of the physical characteristics of the liquid crystal display, such “stuck” pixels may appear spontaneously. These problems are not a malfunction.
- Do not leave the LCD screen facing the sun as it can damage the LCD screen. Take care when you place the unit by a window.
- Do not push or scratch the LCD monitor’s screen. Do not place a heavy object on the LCD monitor’s screen. This may cause the screen to lose uniformity.

- If the unit is used in a cold place, horizontal lines or a residual image may appear on the screen. This is not a malfunction. When the monitor becomes warm, the screen returns to normal.
- If a fixed picture such as a frame of a divided picture or time code, or a still picture is displayed for a long time, an image may remain on the screen and be superimposed as a ghosting image.
- The screen and the cabinet become warm during operation. This is not a malfunction.

About the Fluorescent Tube

A specially designed fluorescent tube is installed as the lighting apparatus for this unit. If the LCD screen becomes dark, unstable or does not turn on, consult your Sony dealer.

On Cleaning

Before cleaning

Be sure to disconnect the AC power cord from the AC outlet.

On cleaning the monitor screen

The monitor screen surface is especially treated to reduce reflection of light.

As incorrect maintenance may impair the performance of the monitor, take care with respect to the following:

- Wipe the screen gently with a soft cloth such as a cleaning cloth or glass cleaning cloth.
- Stubborn stains may be removed with a soft cloth such as a cleaning cloth or glass cleaning cloth lightly dampened with water.
- Never use solvent such as alcohol, benzene or thinner, or acid, alkaline or abrasive detergent, or chemical cleaning cloth, as they will damage the screen surface.

On cleaning the cabinet

- Clean the cabinet gently with a soft dry cloth. Stubborn stains may be removed with a cloth lightly dampened with mild detergent solution, followed by wiping with a soft dry cloth.
- Use of alcohol, benzene, thinner or insecticide may damage the finish of the cabinet or remove the indications on the cabinet. Do not use these chemicals.
- If you rub on the cabinet with a stained cloth, the cabinet may be scratched.
- If the cabinet is in contact with a rubber or vinyl resin product for a long period of time, the finish of the cabinet may deteriorate or the coating may come off.

On Repacking

Do not throw away the carton and packing materials. They make an ideal container which to transport the unit.

On Mounting on a Rack

Leave 1U space empty above and below the monitor to ensure adequate air circulation or install a fan to maintain the monitor's performance.

If you have any questions about this unit, contact your authorized Sony dealer.

On Fan Error

The fan for cooling the unit is built in. When the fan stops and the  (standby) switch indicator on the front panel blinks in green for fan error indication, turn off the power and contact an authorized Sony dealer.

On AC Adaptor Terminal

The AC adaptor terminal of this unit (the connector for AC adaptors) is a consumable part.

The unit may not operate properly if the pins of the AC adaptor terminal are bent or deformed by shock or vibrations, or if they become corroded due to prolonged outdoor use.

Periodic inspections are recommended to keep the unit working properly and to prolong its usable lifetime. Contact your dealer or a Sony service representative for more information about inspections.

Features

The LMD-940W (9 type) is a multiple format LCD monitor for broadcast or business use featuring a precise image and high performance. It supports both digital or analog main broadcast signal and HDMI ¹⁾ input. It is also equipped with functions to adjust for various objects or use.

¹⁾ HDMI, the HDMI logo and High-Definition Multimedia Interface are trademarks or registered trademarks of HDMI Licensing LLC.

High brightness LCD panel

Because of precise image, wide viewing angle technology and high speed response, real color image can be reproduced. Use the light intercepting hood, connector protector and carrying handle (optional Sony VF-510 Monitor ENG Kit) for outdoor use.

Multi-format

The monitor supports video, HDMI, SDI (3G/HD/SD) signals and NTSC/PAL color systems.

For more information, see "Available signal formats" on page 28.

External remote function

The input signal is selected or various items are adjusted by use of the serial (Ethernet) remote function. Up to 32 monitors and control units (max. 4) can be connected by the Ethernet (10BASE-T/100BASE-TX) connection and controlled remotely on the network. You can control individual monitors or monitor groups simply by entering the monitor ID or group ID number. You can also execute the same operation on all connected monitors, or put all connected monitors into the same setup and adjustment state.

For more information, see SERIAL REMOTE of REMOTE menu on page 24.

Refer to the Operation Manual of the BKM-15R Monitor Control Unit.

Rack mount monitors

Using the optional MB-531 Mounting Bracket, up to two monitors may be mounted on the EIA-standard 19-inch rack. A height of 4U space-saving design allows more equipment to be installed in tight space, such as an outdoor broadcasting van.

Monitor stand

You can set the monitor display in 15° by using the stand.

Protection plate

You can attach and detach the LCD screen's protection plate easily with the four screws.

Strong, slim and lightweight

The strong, slim, and lightweight design of the aluminum die-cast chassis makes the monitor suitable for use with rack mounts or as a portable monitor. This reduces the weight burden on an outdoor broadcasting van, and allows for a wider working space.

Two power systems

This unit can also be operated by DC 12V or its exclusive AC power adaptor. The AC power adaptor can be mounted on the rear of the monitor for easy use.

Input signal waveform and audio level display

The waveform of the input signal or the audio level (embedded audio only) can be displayed.

For more information, see SUB INPUT SELECT of "WFM/ALM (waveform monitor and audio level meter) DISPLAY SETTING" on page 21.

Camera focus

This function sharpens the edges of the image more than the amount set by the upper limit of the aperture value in the USER CONTROL menu.

This is convenient for focusing with the camera.

Auto chroma/phase function

The chroma and phase of the decoder are automatically adjusted with the auto chroma/phase function.

Blue only mode

In the blue only mode, a monochrome display is obtained with all three of the R/G/B picture elements driven with a blue signal. This mode is convenient for chroma and phase adjustments and monitoring of VCR noise.

H/V delay mode

The horizontal and vertical sync signals can be monitored simultaneously.

Select marker/scan display

Various items for broadcast use can be displayed. The center marker, aspect marker or display size (scan), etc are displayed by selecting according to use.

For more information, see "MARKER SETTING" on page 21 and SCAN of "FUNCTION BUTTON SETTING" on page 22.

Scan setting /native display

When video signals are input, you can set the display size to 0% scan (normal), 5% over scan (over) or zoom mode (full screen).

A native display function that maps the pixel of the signal to the panel in one-to-one mode is also equipped.

With this, scaling to correct the screen aspect ratio is done to the horizontal direction of SD signals with non-square pixels (number of horizontal pixels of the signal system is 720 or 1440) or 640 × 480 SD signal of HDMI video.

Select color temperature mode

You can select the color temperature from among two settings (9300 K, 6500 K).

Color space function

You can select one from among three color space settings (SMPTE-C/EBU/ITU-R BT.709).

On-screen menus

You can set the appropriate settings according to the connected system by using the on-screen menus.

Select language display

You can select from seven display languages, English, French, German, Spanish, Italian, Japanese and Chinese.

Key inhibit function

You can inhibit a key function to prevent misoperation.

Monaural speaker

The monitor has a monaural speaker to reproduce sound.

Location and Function of Parts and Controls

Front Panel

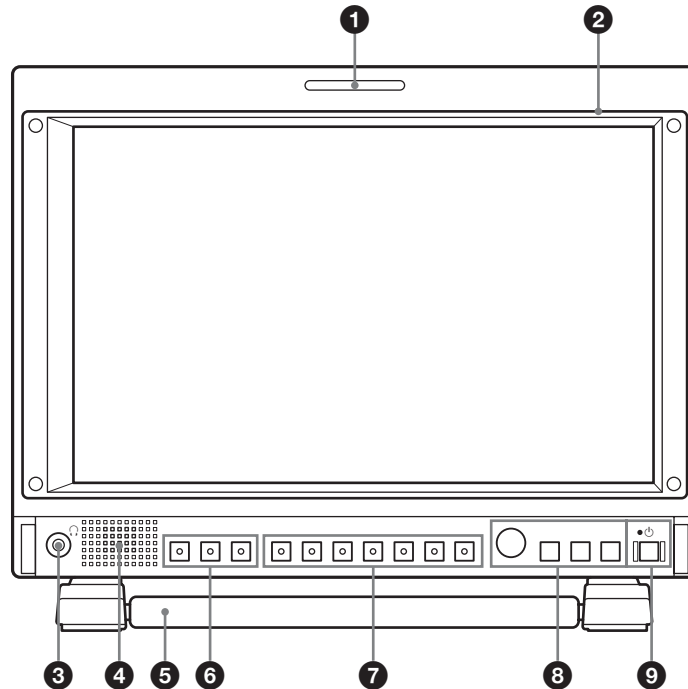

1 Tally lamp

You can check the status of the monitor by the color of the tally lamp.

The tally lamp lights in red, green or amber according to the setting of PARALLEL REMOTE in the REMOTE menu.

2 Protection plate

You can detach the protection plate by removing the four screws.

3 (headphones) jack

The audio signal which is selected by the input select button is output in stereo sound.

4 Speaker

The audio signal which is selected by the input select button is output in monaural sound (L + R).

When SDI signals are input, the audio signal of the channel which is selected in AUDIO SETTING of the USER CONFIG menu is output (see page 20).

The audio signals from the speaker are output from the AUDIO OUT connector on the rear (see page 11).

Audio signals will not be output when headphones are connected to the (headphones) jack.

5 Stand

Pull the stand toward you to tilt the monitor screen by 15°. When using the optional VF-510 Monitor ENG Kit, set the stand at positions B and C. (see "Using the stand" on page 9).

6 Input select buttons

Press to monitor the signal input to each connector.

SDI button: to monitor the signal through the SDI IN connector

HDMI button: to monitor the signal through the HDMI connector

COMPOSITE button: to monitor the signal through the COMPOSITE IN connector

7 Function buttons

You can turn the assigned function on or off.

The factory setting is as follows;

F1 button: BRIGHTNESS

F2 button: CONTRAST

F3 button: CHROMA

F4 button: SCAN

F5 button: H/V DELAY

F6 button: VOLUME

F7 button: I/P MODE

You can assign various functions in FUNCTION BUTTON SETTING of the USER CONFIG menu.

For details of the function assigned to the function button, see page 22.

8 Menu operation buttons

Displays or sets the on-screen menu.

MENU SEL (menu selection) control

When the menu is displayed, turn the control to select a menu item or setting value, and then press the control to confirm the setting.

When the menu is not displayed, press the control to light up the characters that represent the names of the buttons. Press the control again to turn off the lights.

ENTER button

Press to confirm a selected item on the menu.

When the menu is not displayed, press the button to display the distinguished signal format.

RETURN button

When the menu is displayed, press the button to reset the value of an item to the previous value.

When the menu is not displayed, press the button to display the names of the functions selected in FUNCTION BUTTON SETTING of the USER CONFIG menu on the side of the F1 to F7 buttons.

MENU button

Press to display the on-screen menu.

Press again to clear the menu.

9 (standby) switch and indicator

Press to turn on the power when this unit is in standby mode. The indicator lights in green. Press the switch again to set the monitor in standby mode. The indicator goes out. When fan error occurs, the indicator blinks in green. In power saving mode, it lights in amber.

Using the stand

Pull the stand toward you to tilt the monitor screen by 15°.

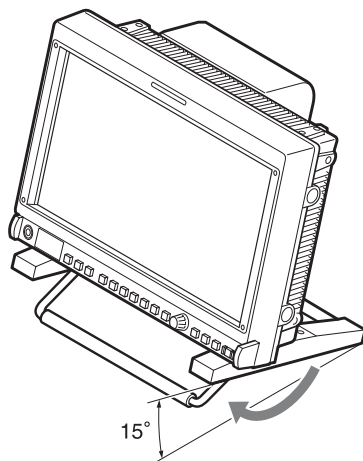

The mounting position of the stand can be changed.

Move the mounting screws on the underside of the stand to positions A and C, or positions B and C.

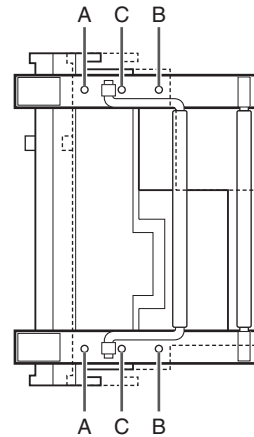

A and C: Sets the stand towards the back.

B and C: Sets the stand towards the front.

When using the optional VF-510 Monitor ENG Kit, set the stand at positions B and C.

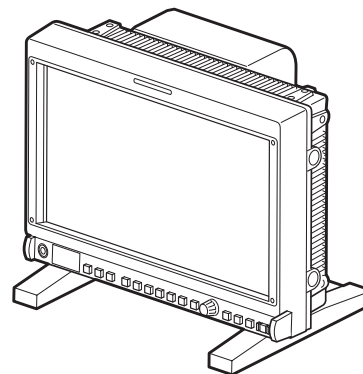

Input Signals and Adjustable/Setting Items

Item	Input signal						
	Video	B & W	SDI			HDMI	
			SD	HD	3G	SD	HD
CONTRAST* ¹	○	○	○	○	○	○	○
BRIGHT* ¹	○	○	○	○	○	○	○
CHROMA* ¹	○	×	○	○	○	○	○
PHASE* ¹	○ (NTSC)	×	×	×	×	×	×
APERTURE	○	○	○	○	○	○	○
COLOR TEMP	○	○	○	○	○	○	○
COLOR SPACE	○	○	○	○	○	○	○
AUTO CHROMA/PHASE	○	×	×	×	×	×	×
ACC	○	×	×	×	×	×	×
CTI	○	×	×	×	×	×	×
V SHARPNESS	○	○	○	×	×	○	×
NTSC SETUP	○ (NTSC)	○ (480/60I)	×	×	×	×	×
SCAN	○	○	○	○	○	○	○
ASPECT	○	○	○	×	×	○	×
MARKER	○	○	○	○	○	○	○
BLUE ONLY	○	×	○	○	○	○	○
MONO	○	×	○	○	○	○	○
H/V DELAY	○	○	○	○	○	×	×
SHIFT	○	○	○	○	○	○	○
POWER SAVING	○	○	○	○	○	○	○
I/P MODE* ²	○	○	○	○	×	○	○
WFM/ALM* ³	○	○	○	○	○	○	○
CAMERA FOCUS	○	○	○	○	○	○	○
RGB RANGE* ⁴	×	×	×	×	×	○	○

○ : Adjustable/can be set

× : Not adjustable/cannot be set

*1 Adjustment of SUB CONTROL is the same.

*2 Only the interlace signal is input.

*3 The audio levels of WFM or ALM are displayed when SDI signal is input. Select the displayed audio level channels in SDI AUDIO SETTING (see "WFM/ALM SELECT" on page 22).

*4 Adjustable when RGB format of HDMI signals are input.

Rear/Bottom Panel

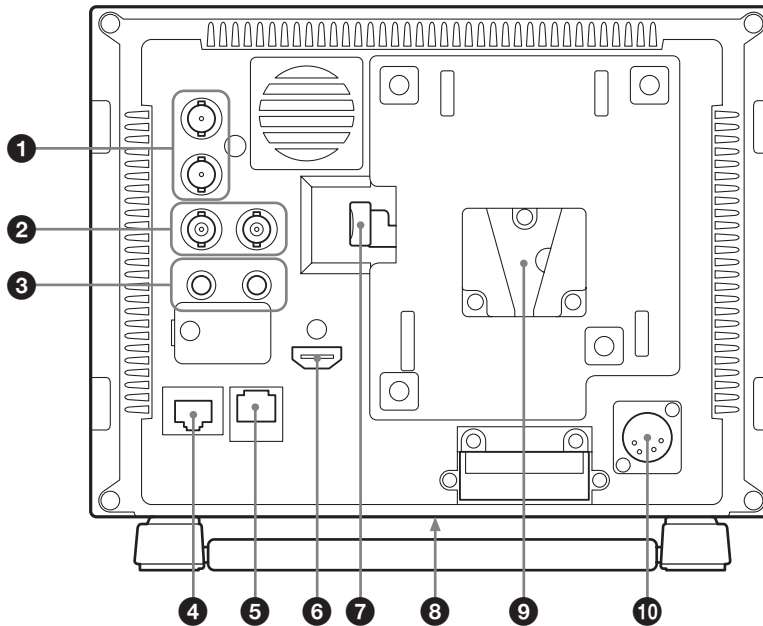

❶ SDI (3G/HD/SD) input and output connectors (BNC)

IN connector

Input connector for serial digital component signals.

OUT connector

Output connector for serial digital component signals.

Note

The signal from the OUT connector does not satisfy the ON-LINE signal specifications.

❷ COMPOSITE input and output connectors (BNC)

IN connector

Input connector for composite video signals or audio signals.

OUT connector

Loop-through output connector.

Note

When inputting a video signal with the jitters, etc. the picture may be disturbed. We recommend using the TBC (time base corrector).

❸ AUDIO input and output connectors (stereo mini jack)

IN connector

Connect to the audio outputs of external equipment such as a VCR.

OUT connector

Outputs the audio signal which is selected by the input select button on the front panel.

When SDI signal is selected, the audio signal of the channel which is selected in AUDIO SETTING of the USER CONFIG menu is output.

❹ PARALLEL REMOTE connector (modular connector, 8-pin)

Forms a parallel switch and controls the monitor externally.

For details on the pin assignment and factory setting function assigned to each pin, see page 28.

CAUTION

For safety, do not connect the connector for peripheral device wiring that might have excessive voltage to this port. Follow the instructions for this port.

❺ SERIAL REMOTE connector (RJ-45)

Connect to the network or Sony BKM-15R Monitor Control Unit by using a 10BASE-T/100BASE-TX LAN cable (shielded type, optional).

For details, refer to the Interface Manual for Programmers (saved in the supplied CD-ROM, Japanese and English only).

CAUTION

- For safety, do not connect the connector for peripheral device wiring that might have excessive voltage to this port. Follow the instructions for this port.
- When an optional LAN cable is connected, use a shield type cable to prevent miss-operation due to noises.
- The connection speed may be affected by the network system. This unit does not guarantee the communication speed or quality of 10BASE-T/100BASE-TX.

⑥ HDMI input connector

Input connector for HDMI signals.

HDMI (High-Definition Multimedia Interface) is an interface that supports both video and audio on a single digital connection, allowing you to enjoy high quality digital picture and sound. The HDMI specification supports HDCP (High-bandwidth Digital Content Protection), a copy protection technology that incorporates coding technology for digital video signals.

Note

Use HDMI compliant cable (optional) with HDMI logo.

⑦ EJECT button

While sliding this button, remove the AC adaptor.

⑧ Tripod socket hole (1/4-20UNC, 3/8-16UNC)

When using a tripod, secure it to the monitor with this hole.

⑨ AC adaptor attachment

The monitor can also be operated with AC power by attaching the AC adaptor.

⑩ DC 12V IN jack (XLR-type, 4-pin)

Connects the DC 12V external power source to use the monitor.

Installing to the Rack (Using MB-531)

You can attach up to two monitors to the rack by using the optional MB-531 Mounting Bracket.

1 Attach the mounting bracket to the monitor.

For details on attaching the mounting bracket, refer to the Mounting Instructions of the MB-531.

2 Attach the unit to the rack with four screws.

Note

The screws are not supplied. Prepare screws according to the rack.

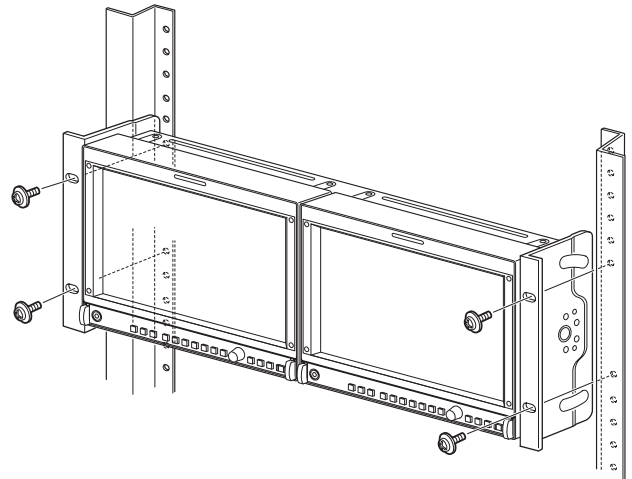

Power Supply

Attaching the AC Adaptor

Attaching

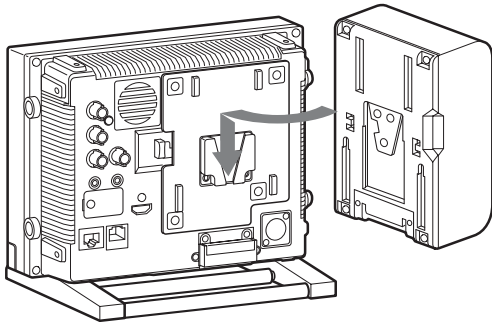

Removing

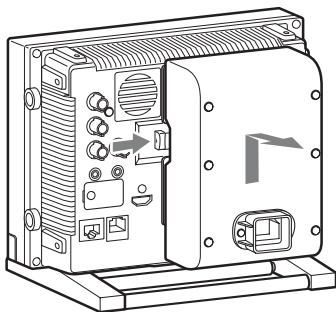

Notes

- The AC adaptor is for LMD-940W only. It cannot be used with other products.
- To remove the AC adaptor, first unplug the AC power cord and then remove the AC adaptor.

Connecting the AC Power Cord

Attach the AC adaptor to the monitor, and then connect the supplied AC power cord.

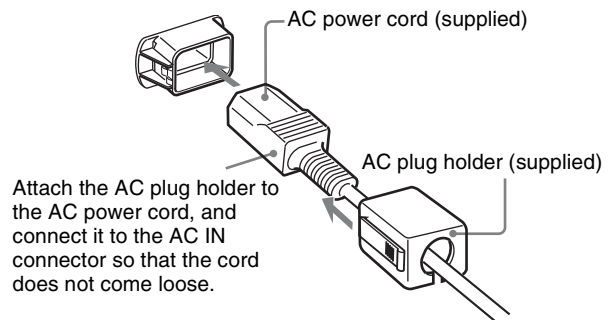

Selecting the Default Settings

When you turn on the unit for the first time after purchasing it, select the area where you intend to use this unit from among the options.

The default setting values for each area

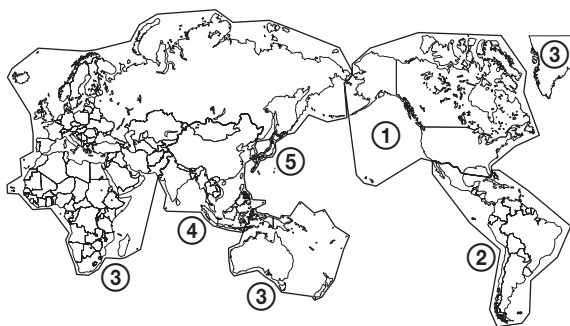

		COLOR TEMP	NTSC SETUP	COLOR SPACE
① NORTH AMERICA		D65	7.5	SMPTE-C
② LATIN AMERICA	ARGENTINA	D65	0	EBU
	PAL&PAL-N AREA PARAGUAY	D65	0	EBU
	URUGUAY	D65	0	EBU
	NTSC&PAL-M AREA OTHER AREA	D65	7.5	SMPTE-C
③ AFRICA AUSTRALASIA EUROPE MIDDLE-EAST		D65	0	EBU
④ ASIA EXCEPT JAPAN	NTSC AREA	D65	7.5	SMPTE-C
	PAL AREA	D65	0	EBU
⑤ JAPAN		D93	0	EBU

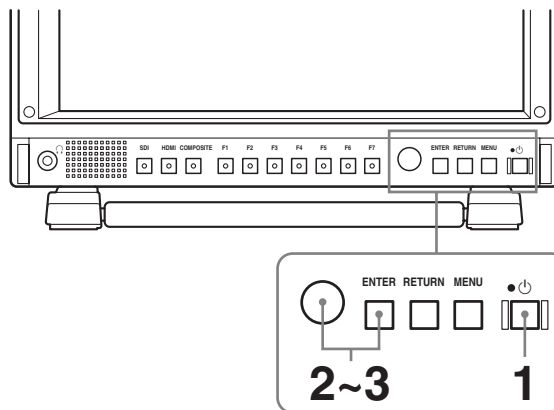

1 Press the ⏻ (standby) switch.

The unit is turned on and the SELECT SETTING screen appears.

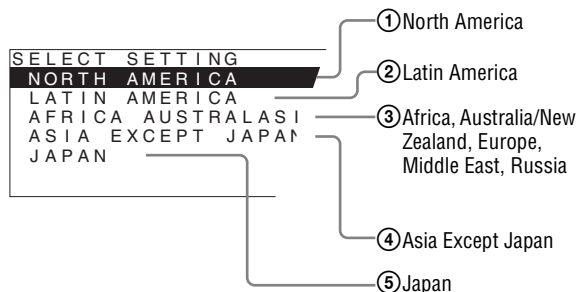

2 Turn the MENU SEL control to select the area where you intend to use the unit and press the MENU SEL control or the ENTER button.

If you select either ①, ③ or ⑤

The confirmation screen is displayed. Confirm the selected area. When the setting is wrong, press the RETURN button to return to the previous screen.

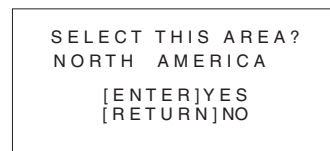

If you select either ② or ④

One of the following screens appears. Turn the MENU SEL control to narrow the area further and then press the MENU SEL control or the ENTER button.

The confirmation screen is displayed. Confirm the selected area.

If the setting is wrong, press the RETURN button to return to the previous screen.

② If LATIN AMERICA is selected:

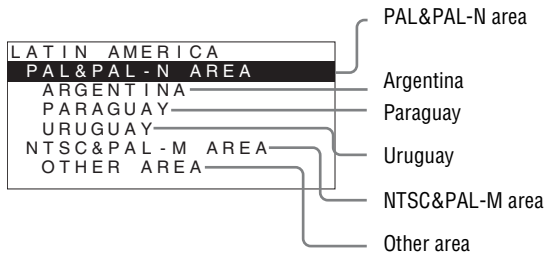

④ If ASIA EXCEPT JAPAN is selected:

Customers who will use this unit in the shaded areas shown in the map below should select NTSC AREA. Other customers should select PAL AREA.

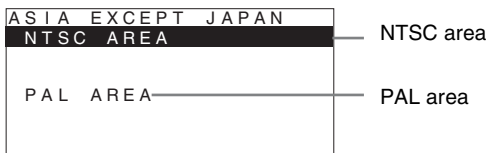
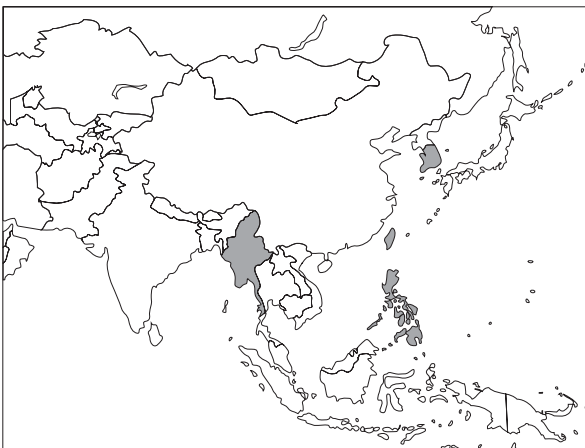

3 Press the MENU SEL control or the ENTER button.

The SELECT SETTING screen disappears and the menu item settings suitable for the selected area are applied.

Note

When you have selected the wrong area, set the following items using the menu.

- COLOR TEMP (on page 19)
- NTSC SETUP (on page 20)
- COLOR SPACE (on page 19)

See “The default setting values for each area” (page 14) on the setting value.

Selecting the Menu Language

You can select one of seven languages (English, French, German, Spanish, Italian, Japanese, Chinese) for displaying the menu and other on-screen displays. “ENGLISH (English)” is selected in the default setting. The current settings are displayed in place of the ■ marks on the illustrations of the menu screen.

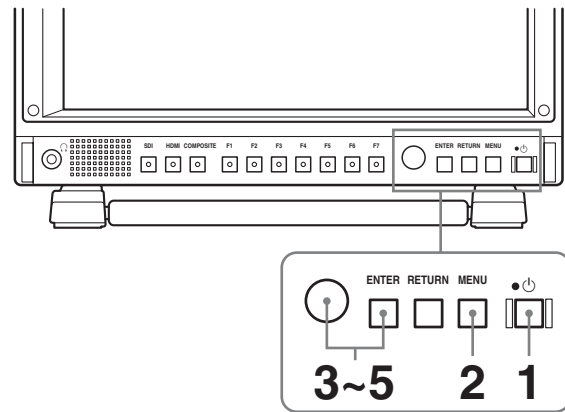

- 1 Turn on the unit.
- 2 Press the MENU button.

The menu appears. The menu presently selected is shown in yellow.

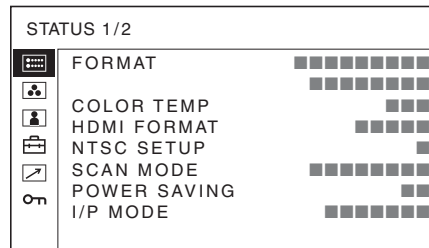

- 3 Turn the MENU SEL control to select SYSTEM SETTING of the USER CONFIG (user configuration) menu, then press the MENU SEL control or the ENTER button.

The setting items (icons) in the selected menu are displayed in yellow.

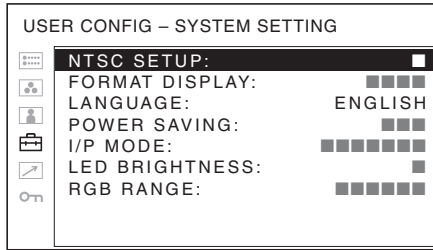

- Turn the MENU SEL control to select “LANGUAGE”, then press the MENU SEL control or the ENTER button.

The selected item is displayed in yellow.

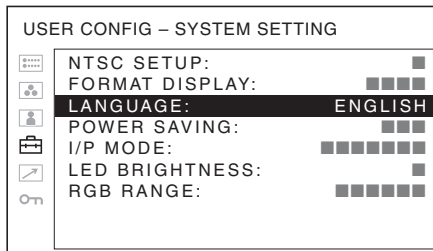

- Turn the MENU SEL control to select a language, then press the MENU SEL control or the ENTER button.

The menu changes to the selected language.

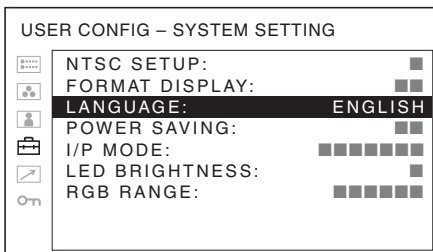

To clear the menu

Press the MENU button.

The menu disappears automatically if a button is not pressed for one minute.

Using the Menu

The unit is equipped with an on-screen menu for making various adjustments and settings such as picture control, input setting, set setting change, etc. You can also change the menu language displayed in the on-screen menu.

To change the menu language, see “Selecting the Menu Language” on page 15.

The current settings are displayed in place of the ■ marks on the illustrations of the menu screen.

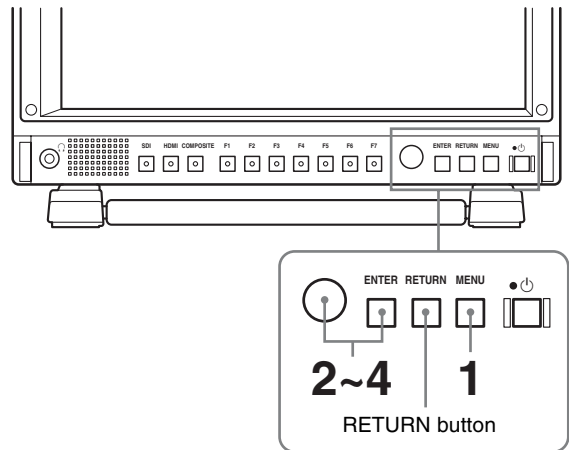

- Press the MENU button.

The menu appears.

The menu presently selected is shown in yellow.

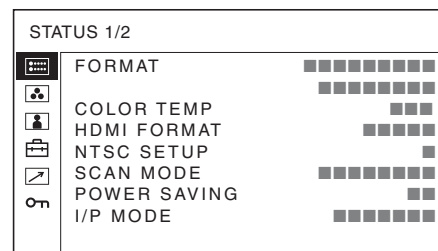

- Turn the MENU SEL control to select a menu, then press the MENU SEL control or the ENTER button.

The menu icon presently selected is shown in yellow and setting items are displayed.

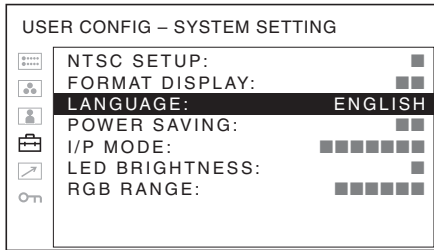

The menu disappears automatically if a button is not pressed for one minute.

About the memory of the settings

The settings are automatically stored in the monitor memory.

3 Select an item.

Turn the MENU SEL control to select the item, then press the MENU SEL control or the ENTER button.

The item to be changed is displayed in yellow. If the menu consists of multiple pages, turn the MENU SEL control to go to the desired menu page.

4 Make the setting or adjustment on an item.

When changing the adjustment level:

To increase the number, turn the MENU SEL control right.

To decrease the number, turn the MENU SEL control left.

Press the MENU SEL control or the ENTER button to confirm the number, then restore the original screen.

When changing the setting:

Turn the MENU SEL control to change the setting, then press the MENU SEL control or the ENTER button to confirm the setting.

When returning the adjustment or setting to the previous value:

Press the RETURN button before pressing the MENU SEL control or the ENTER button.

Notes

- An item displayed in black cannot be accessed. You can access the item if it is displayed in white.
- If the key inhibit has been turned on, all items are displayed in black. To change any of the items, turn the key inhibit to OFF first.

For details on the key inhibit, see page 25.

To return the display to the previous screen

Press the RETURN button.

To clear the menu

Press the MENU button.

Adjustment Using the Menus

Items

The screen menu of this monitor consists of the following items.

STATUS (the items indicate the current settings.)

FORMAT
COLOR TEMP
HDMI FORMAT
NTSC SETUP
SCAN MODE
POWER SAVING
I/P MODE
Model name and serial number

COLOR TEMP/SPACE

COLOR TEMP
MANUAL ADJUSTMENT
COLOR SPACE

USER CONTROL

SUB CONTROL
AUTO CHROMA/PHASE
PICTURE CONTROL
INPUT SETTING

USER CONFIG

SYSTEM SETTING
NTSC SETUP
FORMAT DISPLAY
LANGUAGE
POWER SAVING
I/P MODE
LED BRIGHTNESS
RGB RANGE
MARKER SETTING
MARKER ENABLE
MARKER SELECT
CENTER MARKER
MARKER LEVEL
MARKER MAT
WFM/ALM (waveform monitor and audio level meter) DISPLAY SETTING
WFM/ALM
WFM/ALM SELECT
POSITION
TRANSPARENCY
FUNCTION BUTTON SETTING

F1 BUTTON
F2 BUTTON
F3 BUTTON
F4 BUTTON
F5 BUTTON
F6 BUTTON
F7 BUTTON
AUDIO SETTING
SDI AUDIO SETTING

REMOTE

PARALLEL REMOTE
SERIAL REMOTE

KEY INHIBIT

KEY INHIBIT

Adjusting and Changing the Settings

STATUS menu

The STATUS menu is used to display the current status of the unit. The following items are displayed:

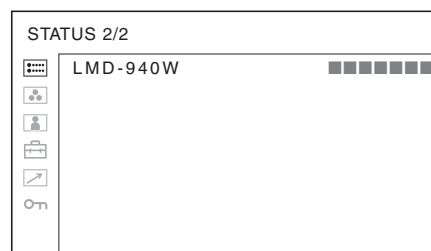
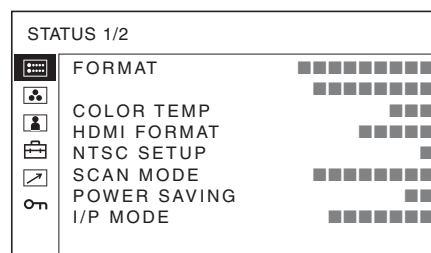

- Signal format
- Color temperature
- HDMI format
- NTSC setup
- Scan mode
- Power saving
- I/P mode
- Model name and serial number

COLOR TEMP/SPACE menu

The COLOR TEMP/SPACE menu is used for adjusting the picture white balance or color space.

You need to use the measurement instrument to adjust the white balance.

Recommended: Konica Minolta color analyzer CA-210

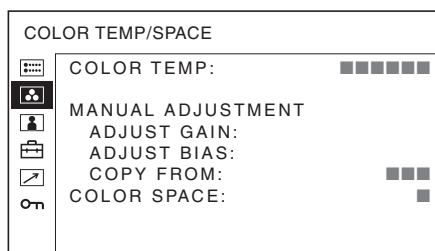

Submenu	Setting
COLOR TEMP	Selects the color temperature from among D65, D93 and USER setting.
MANUAL ADJUSTMENT	<p>If you set the COLOR TEMP to USER setting, the item displayed is changed from black to white, which means you can adjust the color temperature.</p> <p>The set values are memorized.</p> <ul style="list-style-type: none"> • ADJUST GAIN: Adjusts the color balance (GAIN). • ADJUST BIAS: Adjusts the color balance (BIAS). • COPY FROM: If you select D65 or D93, the white balance data for the selected color temperature will be copied in the USER setting.
COLOR SPACE	Selects the color space from among EBU, SMPTE-C, ITU-709 and OFF. OFF sets the color space to the original color reproduction of the LCD panel.

USER CONTROL menu

The USER CONTROL menu is used for adjusting the picture.

Items that cannot be adjusted depending on the input signal are displayed in black.

For details of input signal and adjustable / setting items, see page 10.

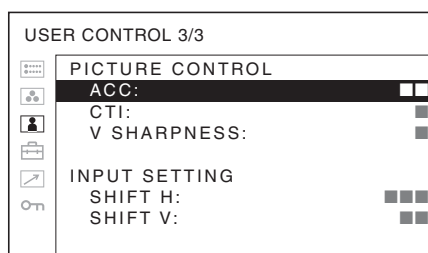
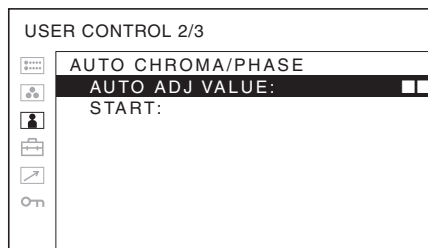
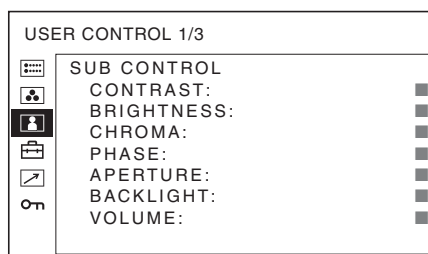

Submenu	Setting
SUB CONTROL	<p>Adjusts finely the adjustment range of the function buttons which CONTRAST, BRIGHTNESS, CHROMA and PHASE are assigned.</p> <ul style="list-style-type: none"> • CONTRAST: Adjusts the picture contrast. • BRIGHTNESS: Adjusts the picture brightness. • CHROMA: Adjusts color intensity. The higher the setting, the greater the intensity. The lower the setting, the lower the intensity. • PHASE: Adjusts color tones. The higher the setting, the more greenish the picture. The lower the setting, the more purplish the picture. • APERTURE: Adjusts the picture sharpness. The higher the setting, the sharper the picture. The lower the setting, the softer the picture. APERTURE does not work when the camera focus function is activated. • BACKLIGHT: Adjusts the backlight. When the setting is changed, the brightness of the backlight is changed. • VOLUME: Adjusts the volume.

Submenu	Setting
AUTO CHROMA/ PHASE	<p>Adjusts color intensity (CHROMA) and tones (PHASE).</p> <ul style="list-style-type: none"> • AUTO ADJ VALUE: Selects ON or OFF of the auto adjustment. When you set to OFF, this parameter is reset to the factory setting. When you set to ON, the automatically adjusted value is enabled. • START: The auto adjustment starts when you display the color bar signals (Full/SMPTE/EIA) on the screen and press the ENTER button. After adjusting the color intensity, press the MENU button to clear the adjustment screen. After the adjustment is done correctly, the AUTO ADJ VALUE is automatically set to ON.
PICTURE CONTROL	<p>Adjusts the picture.</p> <ul style="list-style-type: none"> • ACC (Auto Color Control): Sets ACC circuit on or off. To check the fine adjustment, select OFF. Normally select ON. • CTI (Chroma Transient Improvement): When a low color resolution signal is input, a crisp image can be displayed. When the setting is higher, the picture becomes even more crisp. • V SHARPNESS: A crisp image can be displayed. When the setting is higher, the picture becomes even more crisp.
INPUT SETTING	<ul style="list-style-type: none"> • SHIFT H: Adjusts the position of the picture. As the setting increases, the picture moves to the right, and as the setting decreases, the picture moves to the left. • SHIFT V: Adjusts the position of the picture. As the setting increases, the picture moves up, and as the setting decreases, the picture moves down.

USER CONFIG menu

The USER CONFIG menu is used for setting the system, marker, WFM/ALM display, function button, and audio.

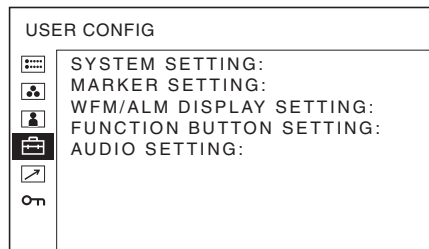

SYSTEM SETTING

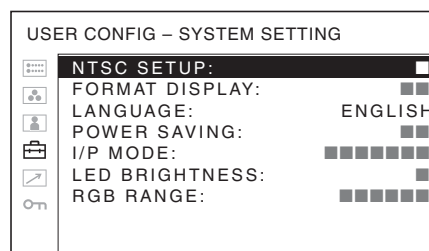

Submenu	Setting
NTSC SETUP	<p>Selects the NTSC setup level from two modes.</p> <p>The 7.5 setup level is used mainly in North America. The 0 setup level is used mainly in Japan.</p>
FORMAT DISPLAY	<p>Selects the display mode of the signal format and scan mode.</p> <ul style="list-style-type: none"> • ON: The format and scan mode are always displayed. • OFF: The display is hidden. • AUTO: The format and scan mode are displayed for about 10 seconds when the input of the signal starts.
LANGUAGE	<p>Selects the menu or message language from among seven languages.</p> <ul style="list-style-type: none"> • ENGLISH: English • FRANÇAIS: French • DEUTSCH: German • ESPAÑOL: Spanish • ITALIANO: Italian • 日本語: Japanese • 中文: Chinese
POWER SAVING	<p>Sets the power saving mode on or off. When you set to ON, the monitor goes into power saving mode if no signal is input for about one minute.</p>

Submenu	Setting
I/P MODE (picture delay minimum)	<p>Selects to set the delay by the picture processing to the minimum level when the interlace signal is input.</p> <ul style="list-style-type: none"> • INTER-FIELD: Mode for giving precedence to the picture quality. Performs interpolation depending on the movement of the images between the fields. It takes longer than "FIELD MERGE" or "LINE DOUBLER" for processing the picture. "INTER-FIELD" is the factory setting. • FIELD MERGE: The processing time is shorter. Combines the lines in the odd fields and even fields alternately regardless of the movement of images. Suitable for viewing still images. • LINE DOUBLER: The processing time is shorter. Performs interpolation by repeating each line in the data receiving sequence regardless of the field. As the line flicker is displayed in this mode, it is available for checking the line flicker of the telop work and so on.
LED BRIGHTNESS	<p>Sets the brightness of the LED of the buttons.</p> <ul style="list-style-type: none"> • 0: The LED becomes brighter. • 1: The LED becomes darker.
RGB RANGE	<p>Sets the black level and white level for the RGB format of HDMI signals.</p> <ul style="list-style-type: none"> • FULL: 0 (black level) to 255 (white level) • LIMITED: 16 (black level) to 235 (white level)

MARKER SETTING

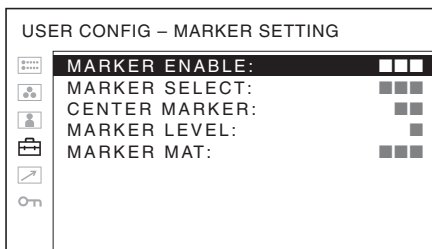

Submenu	Setting
MARKER ENABLE	<p>Selects ON to display the marker and OFF not to display.</p> <p>Note</p> <p>When NATIVE is selected in the SCAN setting, the marker is not displayed. To display the marker, select a setting other than NATIVE.</p>
MARKER SELECT	<p>Selects the aspect ratio according to the film, when the frame of the film is displayed on the screen.</p> <p>When 16:9 aspect ratio is selected with the button which the aspect function is assigned</p> <p>You can select from among 4:3, 15:9, 14:9, 13:9, 1.85:1, 2.35:1, 1.85:1 & 4:3 and OFF.</p> <p>When 4:3 aspect ratio is selected with the button which the aspect function is assigned</p> <p>You can select 16:9 or OFF.</p>
CENTER MARKER	<p>Selects ON to display the center mark of the picture and OFF not to display.</p>
MARKER LEVEL	<p>Sets the luminance to display the MARKER SELECT and CENTER MARKER. You can select from among 1 to 3. When the setting is low, the marker is displayed dark.</p>
MARKER MAT	<p>Selects whether you put mat on the outside of the marker display.</p> <ul style="list-style-type: none"> • OFF: No mat is put. • HALF: Gray mat is put. • BLACK: Black mat is put.

WFM/ALM (waveform monitor and audio level meter) DISPLAY SETTING

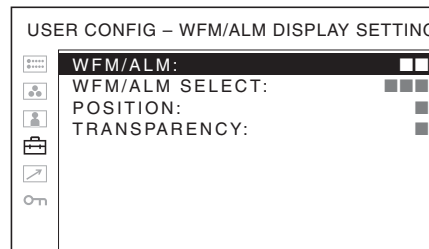

Submenu	Setting
WFM/ALM	<p>Selects ON to display the WFM/ALM display and OFF not to display.</p> <p>Note</p> <p>When the WFM/ALM display is enabled, the marker display is not available.</p>

Submenu	Setting
WFM/ALM SELECT	<ul style="list-style-type: none"> • WFM: A waveform monitor is displayed. • ALM: An audio level meter is displayed. <p>When WFM is selected, the waveform and audio level are displayed. When ALM is selected, the audio level is displayed in eight channels. The audio levels of WFM or ALM are displayed when SDI signal is input. Select the displayed audio level channels in SDI AUDIO SETTING. The indications of the waveform (only when WFM is selected) and audio level signify as illustrated below, although the percentage of the waveform, units and values of the scale for the audio level do not appear on the display.</p>

When WFM is selected

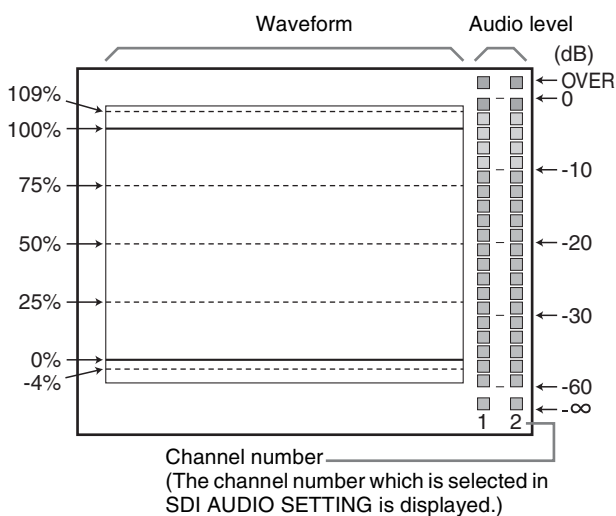

When ALM is selected

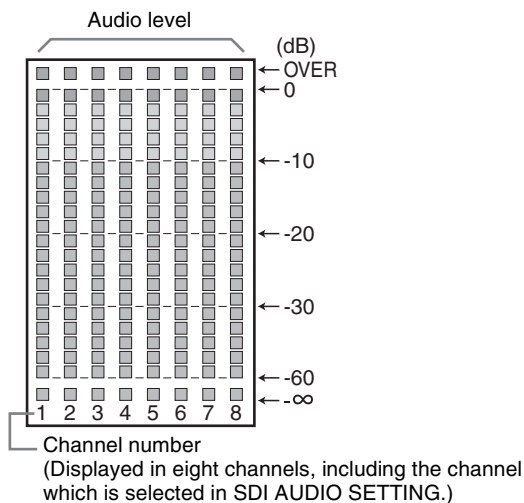

Submenu	Setting
POSITION	<p>Sets the position of the WFM/ALM display. You can select from among 1 to 4.</p> <ul style="list-style-type: none"> • 1: Bottom left • 2: Bottom right • 3: Top right • 4: Top left
TRANSPARENCY	<p>Selects from black and half (transparent) for the background of the WFM/ALM display.</p> <ul style="list-style-type: none"> • BLACK: The background is black. Displayed image is hidden behind the background. • HALF: The background is transparent. Displayed image can be seen indistinctly behind the WFM/ALM display.

FUNCTION BUTTON SETTING

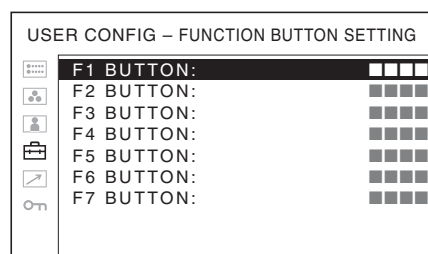

Submenu	Setting
F1 BUTTON to F7 BUTTON	<p>Assigns the function to the function buttons of the front panel and turns the function on or off. You can assign the function from among SCAN, ASPECT, BLUE ONLY, MONO, MARKER, I/P MODE and WFM/ALM.</p> <p>Factory setting</p> <ul style="list-style-type: none"> • F1 button: BRIGHTNESS • F2 button: CONTRAST • F3 button: CHROMA • F4 button: SCAN • F5 button: H/V DELAY • F6 button: VOLUME • F7 button: I/P MODE

About the function assigned to the function button

SCAN

Press the button to change the scan size of the picture. With every press of the button for the 4:3 display, the picture switches in the sequence NORMAL scan → OVER scan → NATIVE. With every press of the button for the 16:9 display, the picture switches in the sequence NORMAL scan → OVER scan → FULL screen → NATIVE (see "Scan mode image" on page 23).

ASPECT

Press the button to set the aspect ratio of the picture, 4:3 or 16:9.

Note

The panel of the monitor is 15:9.
When the 16:9 signal is displayed, black bars appear in the upper and lower positions of the display. This is not a malfunction (see "Scan mode image" on page 23).

BLUE ONLY

Press the button to eliminate the red and green signals. Only blue signal is displayed as an apparent monochrome picture on the screen. This facilitates "chroma" and "phase" adjustments and observation of VCR noise.

MONO

Press the button to display a monochrome picture. When the buttons is pressed again, the monitor switches automatically to color mode.

MARKER

Press the button to display the marker. Set the aspect marker in the MARKER SETTING menu (see page 21).

H/V DELAY

Press the button to observe the horizontal and vertical sync signals at the same time.

WFM/ALM

Press the button to display the WFM/ALM display. Set the WFM/ALM display setting in the WFM/ALM DISPLAY SETTING menu (see page 21).

BRIGHTNESS

Press the button to adjust the picture brightness. Turn the MENU SEL control right to increase the brightness and turn left to decrease it.

CONTRAST

Press the button to adjust the picture contrast. Turn the MENU SEL control right to increase the contrast and turn left to decrease it.

CHROMA

Press the button to adjust the color intensity. Turn the MENU SEL control right to increase the intensity and turn left to decrease it.

VOLUME

Press the button to adjust the volume. Turn the MENU SEL control right to increase the volume and turn left to decrease it.

I/P MODE

Press the button to set the delay by the picture processing to the minimum level when interlace signal is input. The mode switches in the sequence INTER-

FIELD → FIELD MERGE → LINE DOUBLER with every press of the button (see "I/P MODE" on page 21).

PHASE

Press the button to adjust the color tones. Turn the MENU SEL control right to increase the green tone and turn left to increase the purple tone.

APERTURE

Press the button to adjust the picture sharpness. Turn the MENU SEL control right to make the picture sharper and turn left to make the picture softer.

CAMERA FOCUS

Press the button to confirm the camera focus. An image with sharpened edges is displayed.

Scan mode image

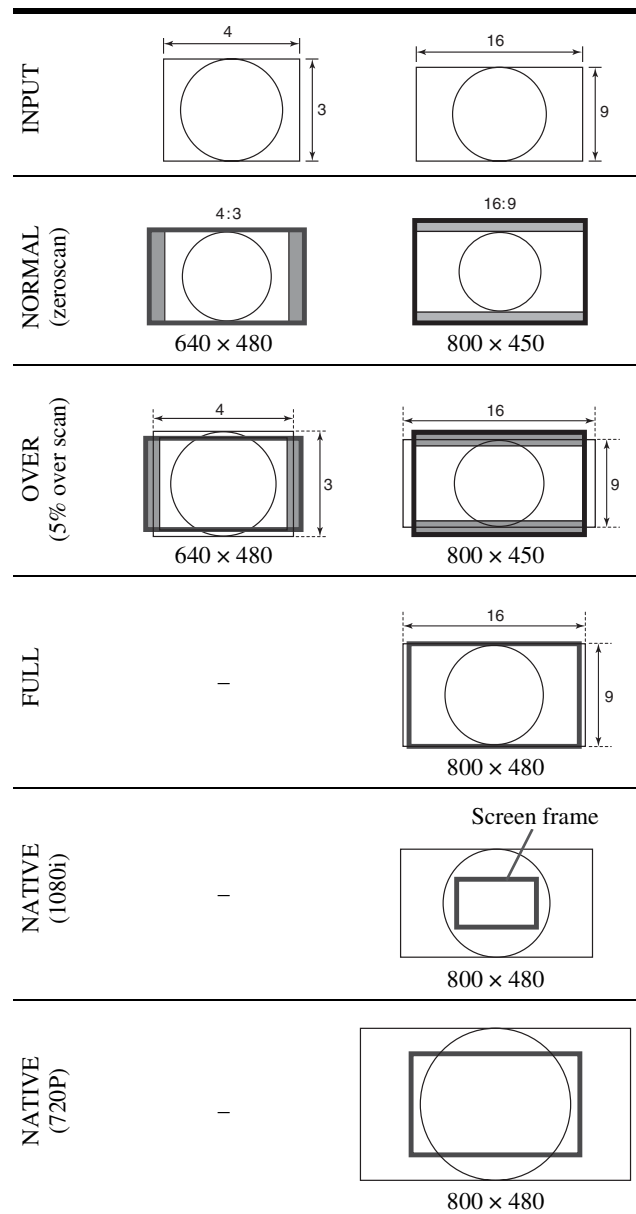

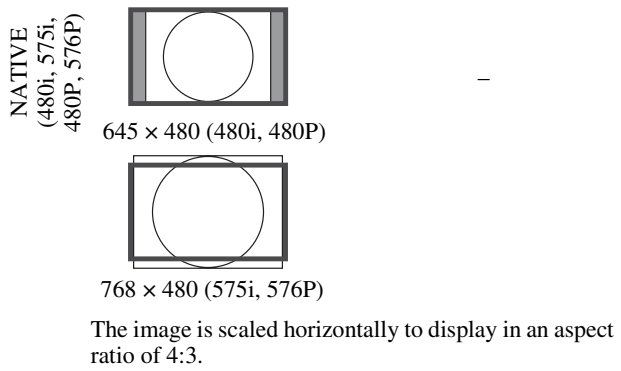
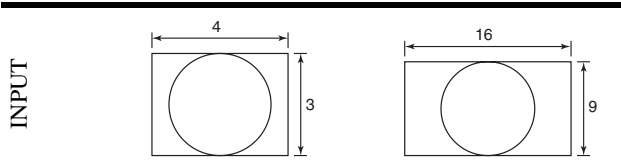

AUDIO SETTING

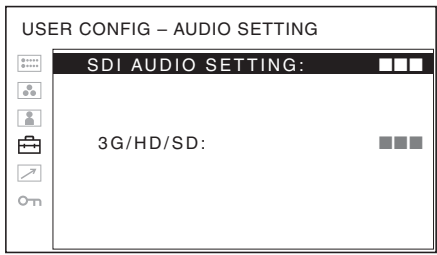

Submenu	Setting
SDI AUDIO SETTING	<p>Sets the audio channel when SDI signal is input.</p> <ul style="list-style-type: none"> 3G/HD/SD: Selects from among channels CH1 to CH16, odd channel + even channel (CH1+CH2, CH3+CH4...CH15+CH16) and OFF. <p>You can display the L/R audio levels of the selected channels on the display when the WFM/ALM display is enabled (see "WFM/ALM (waveform monitor and audio level meter) DISPLAY SETTING" on page 21).</p>

Submenu	Setting
PARALLEL REMOTE	<p>Selects the PARALLEL REMOTE connector pins for which you want to change the function. You can assign various functions to 1 to 4 pins and 6 to 8 pins. The following lists the functions you can assign to the pins.</p> <ul style="list-style-type: none"> ---- ("----": No function is assigned.) COMPOSITE SDI HDMI OVERSCAN FULL NORMAL NATIVE 4:3 16:9 TALLY R TALLY G BLUE ONLY MONO H/V DELAY 16:9 MARKER 15:9 MARKER 14:9 MARKER 13:9 MARKER 1.85:1 MARKER 2.35:1 MARKER 1.85:1 & 4:3 MARKER 4:3 MARKER CENTER MARKER MARKER MAT HALF MARKER MAT BLACK WFM/ALM

Notes

- If you use the PARALLEL REMOTE function, you need to connect cables. For more details, see page 28.
- Set MARKER ENABLE (page 21) to ON to control the aspect marker and center marker.

REMOTE menu

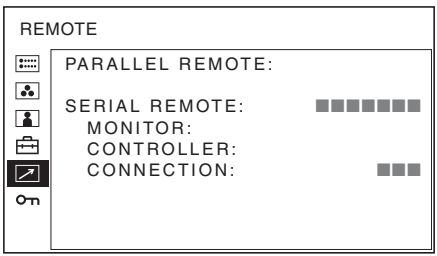

Submenu	Setting
SERIAL REMOTE	<p>Selects the mode to be used.</p> <ul style="list-style-type: none"> • OFF: SERIAL REMOTE does not function. • ETHERNET: The monitor is controlled by the command of Ethernet. • BKM-15R: Sets BKM-15R.
MONITOR	<p>Sets the monitor setting.</p> <p>MONITOR ID: Sets the ID of the monitor.</p> <p>GROUP ID: Sets the group ID of the monitor.</p> <p>IP ADDRESS: Sets the IP address.</p> <p>SUBNET MASK: Sets the subnet mask. (255.255.255.000)</p> <p>DEFAULT GATEWAY: Sets the default gateway on or off.</p> <p>ADDRESS: Sets the default gateway.</p> <p>CANCEL: Selects to cancel the setting.</p> <p>CONFIRM: Selects to save the setting.</p>
CONTROLLER	<p>Sets the address of the remote controller.</p> <p>IP ADDRESS: Sets the IP address.</p> <p>SUBNET MASK: Sets the subnet mask. (255.255.255.000)</p> <p>DEFAULT GATEWAY: Sets the default gateway on or off.</p> <p>ADDRESS: Sets the default gateway.</p> <p>CANCEL: Selects to cancel the setting.</p> <p>CONFIRM: Selects to save the setting.</p>
CONNECTION	<p>Sets the connection of the monitor and the controller.</p> <p>PEER TO PEER: for one to one connection</p> <p>LAN: for connection via a network</p>

KEY INHIBIT menu

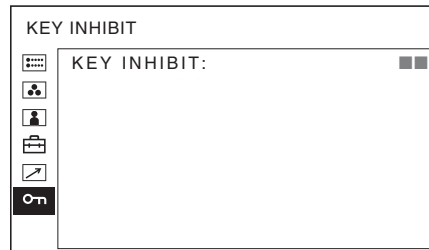

You can lock the setting so that they cannot be changed by an unauthorized user.

Select OFF or ON.

If you set to ON, all items are displayed in black, indicating the items are locked.

Troubleshooting

This section may help you isolate the cause of a problem and as a result, eliminate the need to contact technical support.

- **The unit cannot be operated** → The key protection function works. Set the KEY INHIBIT setting to OFF in the KEY INHIBIT menu.
Or, a function that does not work is assigned. Press the RETURN button to check the assigned functions.
- **The black bars appear at the upper and lower positions of the display** → When the signal aspect ratio is different from that of the panel, the black bars appear. This is not a failure of the unit.
- **Adjustments and settings cannot be made** → Adjustments and settings may not be possible depending on the input signals and the status of the unit. See “Input Signals and Adjustable/Setting Items” (page 10).

Specifications

Picture performance

LCD panel	a-Si TFT Active Matrix
Pixel efficiency	99.99%
Picture size	9 type
Viewing angle (up/down/left/right, contrast > 10:1)	85°/85°/85°/85° (typical)
Scan	Normal 0% Over scan 5%
Efficient picture size	195 × 117, 227 mm (7 ³ / ₄ × 4 ⁵ / ₈ , 9 inches)
Resolution	H 800 dots, V 480 lines
Aspect ratio	15:9

Input

Composite input (NTSC/PAL) connector	BNC type (1) 1 Vp-p ± 3 dB sync negative
SDI input connector	BNC type (1)
HDMI input connector	HDMI (1)
Audio input connector	Stereo mini jack (1) -5 dBu 47 kΩ or higher
Remote input connector	Parallel remote Modular connector 8-pin (1) Serial remote RJ-45 modular connector (ETHERNET) (1)
DC IN connector	DC 12 V (output impedance 0.05 Ω or less)

Output

SDI (3G/HD/SD) output connector	BNC type (1) Output signal amplitude: 800 mVp-p ±10% Output impedance: 75 Ω unbalanced
Composite output connector	BNC type (1) Loop-through, with 75 Ω automatic terminal function
Audio monitor output connector	Stereo mini jack (1)
Built-in speaker output	0.5 W Monaural
Headphones output connector	Stereo mini jack (1)

General

Power	AC 100 to 240 V, 50/60 Hz, 0.5 A to 0.3 A DC 12 V, 1.9 A
Power consumption	Maximum: approx. 27 W
Peak inrush current	(1) Power ON, current probe method: 30 A (100 V), 60 A (240 V) (2) Hot switching inrush current, measured in accordance with European standard EN55103-1: 14 A (230 V)
Dimensions	Approx. 222.4 × 183.5 × 161.8 mm (8 ⁷ / ₈ × 7 ¹ / ₄ × 6 ³ / ₈ inches) (w/h/d)
Mass	Approx. 2.0 kg (4 lb 6 oz) Approx. 2.6 kg (5 lb 12 oz) (when AC adaptor is installed)
Operating conditions	Temperature 0 °C to 40 °C (32 °F to 104 °F) Recommended temperature 20 °C to 30 °C (68 °F to 86 °F) Humidity 30% to 85% (no condensation) Pressure 700 hPa to 1060 hPa
Storage and transport conditions	Temperature -20 °C to +60 °C (-4 °F to +140 °F) Humidity 0% to 90% Pressure 700 hPa to 1060 hPa
Accessories supplied	AC power cord (1) AC power adaptor (1) AC plug holder (1) Operating Instructions (1) CD-ROM (1) Using the CD-ROM Manual (1) Warranty book (1)
Optional accessories	Mounting bracket MB-531 Mounting panel MB-532 Monitor ENG kit VF-510

Design and specifications are subject to change without notice.

Note

Always verify that the unit is operating properly before use. SONY WILL NOT BE LIABLE FOR DAMAGES OF ANY KIND INCLUDING, BUT NOT LIMITED TO, COMPENSATION OR REIMBURSEMENT ON ACCOUNT OF THE LOSS OF PRESENT OR PROSPECTIVE PROFITS DUE TO FAILURE OF THIS UNIT, EITHER DURING THE WARRANTY PERIOD OR AFTER EXPIRATION OF THE WARRANTY, OR FOR ANY OTHER REASON WHATSOEVER.

Pin assignment

PARALLEL REMOTE connector

Modular connector
(8-pin)

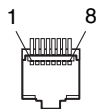

Pin number	Functions
1	Designating SDI input signal
2	Designating HDMI input signal
3	Designating composite input signal
4	Setting tally lamp green ON/OFF

Pin number	Functions
5	GND
6	Setting tally lamp red ON/OFF
7	Selecting over scan
8	Selecting normal scan

You can allocate functions using the REMOTE menu (see page 24).

Wiring required to use the Remote Control

Connect the function you want to use with a Remote Control to the Ground (Pin 5).

Available signal formats

The unit is applicable to the following signal formats.

System	Total lines	Active lines	Frame rate* ³	Scanning	Aspect ratio	Signal standard		
						Analog	SDI (3G/HD/SD)	HDMI
575/50I(PAL)	625	575	25	2:1 interlace	16:9/4:3	PAL:ITU-R BT.470	SMPTE-259M	CEA-861
480/60I(NTSC) * ³	525	483	30	2:1 interlace	16:9/4:3	NTSC:SMPTE-170M	SMPTE-259M	CEA-861
576/50P	625	576	50	Progressive	16:9/4:3	–	–	CEA-861
480/60P * ³	525	483	60	Progressive	16:9/4:3	–	–	CEA-861
640 × 480/60P * ³	525	480	60	Progressive	4:3	–	–	CEA-861
1080/24PsF * ¹ * ³	1125	1080	24	Progressive(sF)	16:9	–	SMPTE RP211	–
1080/25PsF * ² * ³	1125	1080	25	Progressive(sF)	16:9	–	SMPTE RP211	–
1080/24P * ³	1125	1080	24	Progressive	16:9	–	SMPTE-274M	CEA-861
1080/25P	1125	1080	25	Progressive	16:9	–	SMPTE-274M	CEA-861
1080/30P * ³	1125	1080	30	Progressive	16:9	–	SMPTE-274M	CEA-861
1080/50I	1125	1080	25	2:1 interlace	16:9	–	SMPTE-274M	CEA-861
1080/60I * ³	1125	1080	30	2:1 interlace	16:9	–	SMPTE-274M	CEA-861
720/50P	750	720	50	Progressive	16:9	–	SMPTE-296M	CEA-861
720/60P * ³	750	720	60	Progressive	16:9	–	SMPTE-296M	CEA-861
1080/50P * ⁴	1125	1080	50	Progressive	16:9	–	SMPTE-274M	CEA-861
1080/60P * ³ * ⁴	1125	1080	60	Progressive	16:9	–	SMPTE-274M	CEA-861

*1 The format on the screen is displayed as 1080/48I.

*2 The format on the screen is displayed as 1080/50I.

*3 The frame rate is also compatible with 1/1.001.

*4 The format is compatible with 4:2:2 YCbCr 10-bit of 3G-SDI.

Dimensions

Front

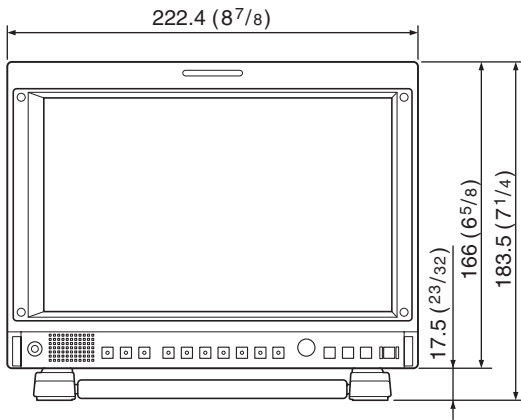

Side

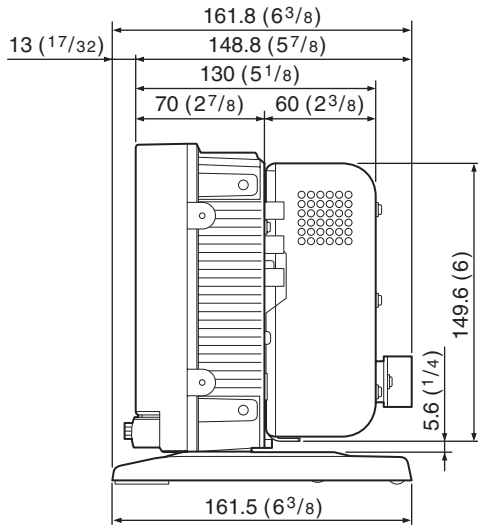

Bottom

(Without the stand)

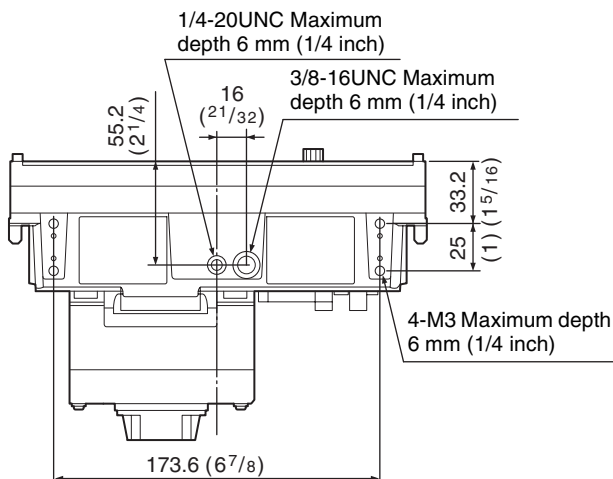

Top

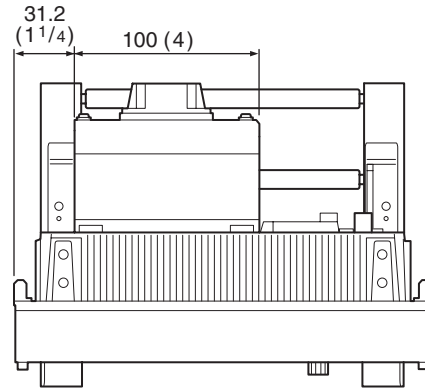

Side

(When the stand is moved)

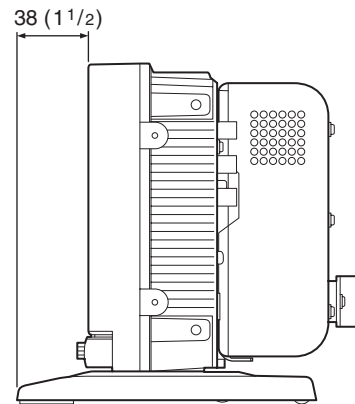

Unit: mm (inches)

Free Manuals Download Website

<http://myh66.com>

<http://usermanuals.us>

<http://www.somanuals.com>

<http://www.4manuals.cc>

<http://www.manual-lib.com>

<http://www.404manual.com>

<http://www.luxmanual.com>

<http://aubethermostatmanual.com>

Golf course search by state

<http://golfingnear.com>

Email search by domain

<http://emailbydomain.com>

Auto manuals search

<http://auto.somanuals.com>

TV manuals search

<http://tv.somanuals.com>