

# *Cordless Telephone*

---

Operating Instructions

**US**

**900**<sup>MHz</sup>  
**CALLER ID**  
with call waiting

*SPP-N1025*

## Owner's Record

The model and the serial numbers are located at the bottom of the unit. Record the serial number in the space provided below. Refer to these numbers whenever you call upon your Sony dealer regarding this product.

Model No. SPP-N1025

Serial No. \_\_\_\_\_

# IMPORTANT SAFETY INSTRUCTIONS

When using your telephone equipment, basic safety precautions should always be followed to reduce the risk of fire, electric shock and injury to persons, including the following:

1. Do not use this product near water, for example, near a bath tub, wash bowl, kitchen sink, or laundry tub, in a wet basement, or near a swimming pool.
2. Avoid using a telephone (other than a cordless type) during an electrical storm. There may be a remote risk of electric shock from lightning.
3. Do not use the telephone to report a gas leak in the vicinity of the leak.
4. Use only the power cord and batteries indicated in this manual. Do not dispose of batteries in a fire. They may explode. Check with local codes for possible special disposal instructions.

# SAVE THESE INSTRUCTIONS

## INFORMATION FOR FCC REGULATION CLAIM

1. This equipment complies with Part 15 and Part 68 of the FCC rules for the United States. On the bottom of this equipment is a label that contains, among other information, the FCC certification number and ringer equivalence number (REN) for this equipment. If requested, this information must be provided to the telephone company.
2. This equipment connect to nationwide telephone network through a modular telephone jack which applicable certification jack (connector) is USOC-RJ11C.
3. The FCC compliant telephone cord and modular plug is provided with this equipment. This equipment is designed to be connected to the telephone network or premises wiring using a compatible modular jack that is part 68 compliant.
4. The REN is used to determine the quantity of devices that may be connected to the telephone line. Excessive RENs on the telephone line may result in the devices not ringing in response to an incoming call. Typically, the sum of the RENs should not exceed five (5.0). To be certain of the number of devices that may be connected to a line, as determined by the total RENs, contact the local telephone company.
5. If this equipment (SPP-N1025) causes harm to the telephone network, the telephone company will notify you in advance that temporary discontinuance of service may be required. But if advance notice isn't practical, the telephone company will notify the customer as soon as possible. Also, you will be advised of your right to file a complaint with the FCC if you believe it is necessary.
6. The telephone company may make changes to it's facilities, equipment, operations or procedures that could affect the operation of the equipment. If this happens the telephone company will provide advance notice so you can make the necessary modifications to maintain uninterrupted service.
7. If trouble is experienced with this equipment (SPP-N1025), for repair or warranty information, please contact Sony Direct Response Center: Tel 1-800-222-7669. If the equipment is causing harm to the telephone network, the telephone company may request that you disconnect the equipment until the problem is resolved.

8. All repairs will be performed in an authorized Sony service station.
9. This equipment may not be used on coin service provided by the Phone Company or Party Lines.
10. This equipment is hearing aid compatible.

When programming emergency numbers and (or) making test calls to emergency numbers:

1. Remain on the line and briefly explain to the dispatcher the reason for the call.
2. Perform such activities in the off-peak hours, such as early morning or late evenings.

Operation is subject to the following two conditions: (1) This device may not cause interference, and (2) This device must accept any interference, including interference that may cause undesired operation.

### Caution

You are cautioned that any changes or modifications not expressly approved in this manual could void your authority to operate this equipment.

Privacy of communications may not be ensured when using this phone.

### Note

This equipment has been tested and found to comply with the limits for a Class B digital device, pursuant to Part 15 of the FCC Rules. These limits are designed to provide reasonable protection against harmful interference in a residential installation. This equipment generates, uses and can radiate radio frequency energy and, if not installed and used in accordance with the instructions, may cause harmful interference to radio communications. However, there is no guarantee that interference will not occur in a particular installation. If this equipment does cause harmful interference to radio or television reception, which can be determined by turning the equipment off and on, the user is encouraged to try to correct the interference by one or more of the following measures:

- Reorient or relocate the receiving antenna.
- Increase the separation between the equipment and receiver.
- Connect the equipment into an outlet on a circuit different from that to which the receiver is connected.
- Consult the dealer or an experienced radio/TV technician for help.

# IMPORTANTES INSTRUCCIONES DE SEGURIDAD

A fin de reducir el riesgo de incendio, descarga eléctrica y lesiones a las personas cuando usted use su equipo telefónico, siempre debe observar precauciones básicas de seguridad, entre ellas:

1. No use este producto cerca del agua, por ejemplo, cerca de una bañera, lavabo, fregadero de cocina o lavadora, en un sótano mojado o cerca de una piscina.
2. Evite usar un teléfono (que no sea del tipo inalámbrico) durante una tormenta eléctrica. Existe la remota posibilidad de shock eléctrico debido a rayos.
3. Para notificar una fuga de gas, no utilice el teléfono en la vecindad de dicha fuga.
4. Utilice solamente el cable de alimentación y las pilas indicados en este manual. No tire las pilas al fuego. Podrían explotar. Compruebe los códigos locales con respecto a las instrucciones especiales sobre cómo deshacerse de ellas.

# GUARDE ESTAS INSTRUCCIONES

## INFORMACIÓN PARA LA DEMANDA DE LA REGLAMENTACIÓN DE LA FCC

1. Este equipo cumple con la Parte 15 y la Parte 68 de las reglas de la FCC para EE.UU. En la base de este equipo hay una etiqueta que contiene, entre otra información, el número de certificado de la FCC y el número de equivalencia de timbre de llamada (REN) para este equipo. Cuando se solicite, esta información deberá ofrecerse a la compañía telefónica.

2. Este equipo se conecta a la red telefónica nacional a través de una toma telefónica modular cuya toma (conector) de certificado aplicable es USOC-RJ11C.
3. Con este equipo se suministran un cable telefónico y una clavija modular que cumplen las normas de la FCC. Este equipo ha sido diseñado para conectarse a la red telefónica o la instalación de un usuario utilizando una toma modular compatible que esté de acuerdo con la Parte 68.
4. El REN se utiliza para determinar la cantidad de dispositivos que podrán conectarse a la línea telefónica. El exceso de REN conectados a la línea telefónica puede resultar en que los dispositivos no contesten a llamadas entrantes. Normalmente, la suma de REN no deberá ser superior a cinco (5,0). Para enterarse del número total de REN que puede conectarse a una línea, póngase en contacto con la compañía telefónica.
5. Si este equipo (SPP-N1025) produce daños en la red telefónica, la compañía telefónica le notificará con antelación que es posible que se requiera la interrupción temporal del servicio. Pero si la notificación con antelación no es práctica, la compañía telefónica lo notificará al cliente lo antes posible. Además, se le notificará el derecho a realizar una reclamación a la FCC si usted lo considera necesario.
6. La compañía telefónica puede realizar cambios en sus instalaciones, equipos, operaciones, o procedimientos que pueden afectar la operación del equipo. Cuando suceda esto, la compañía telefónica le avisará con antelación para que pueda realizar las modificaciones necesarias a fin de mantener ininterrumpido el servicio.
7. Si experimenta algún problema con este equipo (SPP-N1025), con respecto a la reparación o a la información sobre la garantía, póngase en contacto con Sony Direct Response Center: Tel 1-800-222-7669 (EE. UU. solamente). Si el equipo causa problemas en la línea, la compañía telefónica puede solicitarle que desconecte el equipo hasta que se resuelva el problema.
8. Todas las reparaciones deberá realizarlas un centro de reparaciones Sony.
9. Este equipo puede no utilizarse en el servicio de pago previo proporcionado por la compañía telefónica o la línea compartida.
10. Este equipo es compatible con dispositivos para ayuda a la audición.

Cuando programe números de emergencia y (o) realice llamadas de prueba a los mismos:

1. Permanezca poco tiempo en la línea y explique a la otra parte la razón de la llamada.
2. Realice tales actividades en horas no punta, como por la mañana temprano o a últimas horas de la tarde.

La operación está sometida a las dos condiciones siguientes: (1) Este dispositivo puede no causar interferencia, y (2) Este dispositivo deberá aceptar cualquier interferencia, incluyendo la que pueda causar una operación indeseada.

## Precaución

Se le advierte que cualquier cambio o modificación no aprobado expresamente en el presente manual podría anular su autorización para operar este equipo.

El secreto de las comunicaciones puede no asegurarse cuando utilice este teléfono.

## Nota

Este equipo se ha sometido a pruebas y se ha determinado que cumple los límites para un aparato digital Clase B de conformidad con la Parte 15 de las Reglas FCC. Dichos límites están diseñados para brindar protección razonable contra interferencia dañina en una instalación residencial. Este equipo genera, utiliza y puede radiar energía de radiofrecuencia y, si no se instala y se usa de acuerdo con las instrucciones, puede ocasionar interferencia dañina en las radiocomunicaciones. Sin embargo, no hay garantía de que no ocurra interferencia en una instalación específica. En caso de que este equipo ocasione interferencia dañina en la recepción de radio o televisión, que se puede determinar apagando y encendiendo el equipo, se le insta al usuario a que trate de corregir la interferencia mediante una o más de las siguientes medidas:

- Reorientar o reubicar la antena de recepción.
- Aumentar la separación entre el equipo y el receptor.
- Conectar el equipo en un enchufe de un circuito distinto al circuito al cual está conectado el receptor.
- Consultar con el distribuidor o con un técnico experimentado de radio / televisión para ayuda.

---

# Table of contents

## Getting Started

- 6 Step 1: Setting up the base phone
- 9 Step 2: Prepare the battery pack
- 11 Step 3: Change the display language
- 12 Step 4: Choose the dialing mode
- 13 Step 5: Set the date and time
- 14 Identifying the parts

---

## Basics

- 18 Making calls
- 21 Redialing
- 22 Receiving calls

---

## Telephone Features

- 23 One-touch dialing
- 23 Storing phone number
- 24 Making calls with one-touch dialing
- 25 Speed dialing
- 25 Storing phone numbers on the base phone
- 26 Making calls with speed dialing on the base phone
- 27 Phone Directory
- 27 Storing phone numbers and names
- 28 Changing a stored name and/or phone number
- 29 Erasing a memory location
- 30 Making calls from the Phone Directory
- 31 Setting the ringer type
- 31 Turning off the ringer of the handset
- 32 Adjusting the ringer volume level of the base phone
- 33 Switching the phones during a call
- 33 To switch from the base phone to the handset
- 34 To switch from the handset to the base phone

- 35 Talking between the handset and the base phone (Intercom)
- 35 To talk from the handset to the base phone
- 36 To talk from the base phone to the handset
- 37 Having a three-way conference
- 37 To join the phone conversation

## Caller ID Features

- 38 Understanding the Caller ID service
- 38 When you receive a call
- 39 Looking at the Caller ID list
- 39 Viewing the Caller ID list
- 40 Erasing data from the Caller ID list
- 42 Using the Caller ID list
- 42 Calling back a number from the Caller ID list
- 43 Storing a number of the Caller ID list into the Phone Directory
- 44 To change the number of digits of the phone number
- 46 Using "Caller ID with call waiting" service
- 47 Using voice mail service
- 47 If you have messages

## Additional Information

- 49 Mounting the base phone on a wall
- 50 Carrying the handset by the belt clip
- 52 Notes on power sources
- 53 Maintenance
- 54 Troubleshooting
- 57 Specifications
- 58 Index

---

Back cover LIMITED WARRANTY

# Step 1

## Setting up the base phone

Do the following steps:

- Choose the best location
- Connect the base phone

### Choose the best location

Where you place the base phone affects the reception quality of the handset.

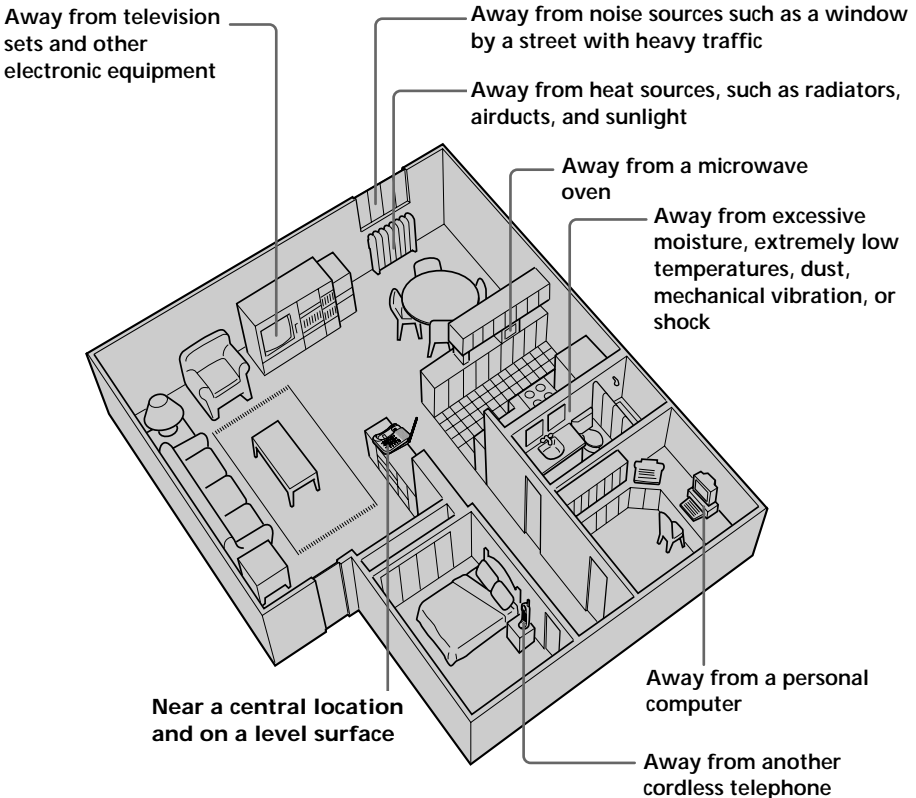

**CAUTION:** • Should you experience intermittent loss of audio during a conversation, try moving closer to the base or move base phone away from other noise sources.  
• The cordless telephone operates at a frequency that may cause interference to nearby TVs and VCRs; the base phone should not be placed near or on the top of a TV or VCR; and, if interference is experienced, moving the cordless telephone farther away from the TV or VCR will often reduce or eliminate the interference.

## Connect the base phone

If you want to hang the base phone on the wall, see page 49.

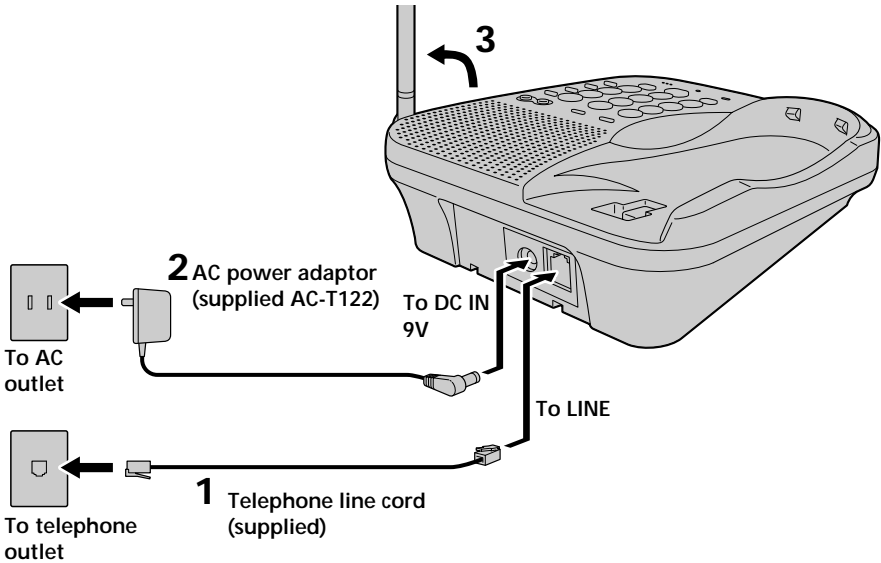

- 1** Connect the telephone line cord to the LINE jack and to a telephone outlet.
- 2** Connect the AC power adaptor to the DC IN 9V jack and to an AC outlet.
- 3** Raise the antenna. Make sure it points towards the ceiling.

continued

---

## Step 1: Setting up the base phone (continued)

### Notes

- Use only the supplied AC-T122 AC power adaptor. Do not use any other AC power adaptor.
- Connect the AC power adaptor to a continuous power supply.
- Place the base phone close to the AC outlet so that you can unplug the AC power adaptor easily.

### Polarity of the plug



### Tip

If your telephone outlet is not modular, contact your telephone service company for assistance.

### Modular





## Step 2

### Prepare the battery pack

Charge the battery pack for more than 12 hours before you start using your phone.

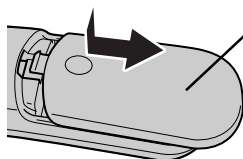

- 1** Slide open the battery compartment lid of the handset.

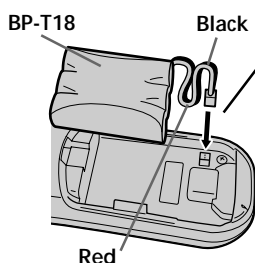

- 2** Connect the battery connector with correct polarity (black wire goes on right side and red wire goes on left).

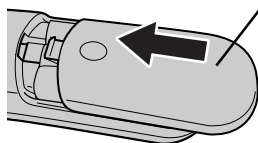

- 3** Insert the battery pack, and close the lid.

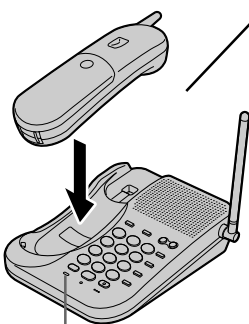

- 4** Place the handset on the base phone.  
The CHARGE lamp lights up when the handset is properly seated on the charge terminals of the base phone. Charge the battery pack for more than 12 hours so that the battery is fully charged. The CHARGE lamp remains lit even after charging is completed.

CHARGE lamp

continued

---

## Step 2: Prepare the battery pack (continued)

### Battery duration

A fully charged battery pack lasts for:

- Approx. 7 hours when you use the handset continuously
- Approx. 7 days when the handset is in standby mode.

### Notes

- The battery pack will gradually discharge over a long period of time, even when not in use.
- If you leave the battery pack in the handset without charging it, the battery pack will be completely discharged.  
It may require several times of charging to recover to its full capacity.
- While charging, the battery pack warms up. This is not a malfunction.

### To obtain the best performance from the battery

Do not place the handset on the base phone after each call. The battery works best if the handset is returned to the base phone after two or three calls. However, do not leave the handset off the base phone for a long period of time as this will completely discharge the battery pack.

### When to purchase a new battery pack

If the battery lasts only a few minutes even after **12 hours** of charging, the usable life of the battery has expired and needs replacement. Contact your local Sony authorized dealer or service center, and ask for Sony **BP-T18** rechargeable battery pack.

### Note

Battery life may vary depending on usage condition and ambient temperature.

## Step 3

### Change the display language

You can choose English or Spanish as the display language by following the procedure below.

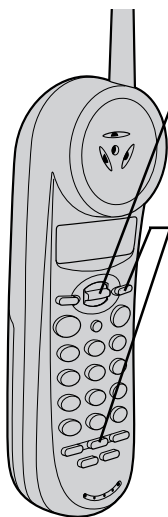

- 1 Press (PGM).
- 2 Raise or lower the Jog lever until “LANGUAGE” or “IDIOMA” appears on the display.

- 3 Press (SELECT).



- 4 Raise or lower the Jog lever to change the display language, and then press (PGM).

You will hear a long confirmation beep.

#### Note

Do not allow more than 20 seconds to elapse between each step of the procedure.

#### Tip

You may press (SELECT) instead of pressing (PGM) in step 4.

## Step 4

### Choose the dialing mode

For the telephone to work properly, select an appropriate dialing mode (tone or pulse).

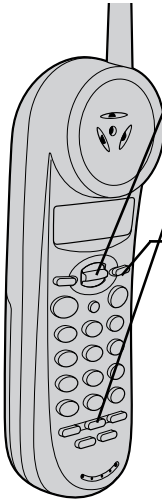

**1** Press **PGM**.

**2** Raise or lower the Jog lever until “DIAL MODE” appears on the display.

**3** Press **SELECT**.

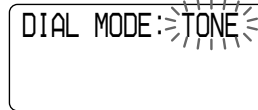

**4** Raise or lower the Jog lever to choose the dialing mode (“TONE” or “PULSE”), and then press **PGM**.  
You will hear a long confirmation beep.

#### Note

Do not allow more than 20 seconds to elapse between each step of the procedure.

#### Tip

You may press **SELECT** instead of pressing **PGM** in step 4.

#### If you aren't sure of your dialing system

Make a trial call with the dialing mode set to “TONE”.

If the call connects, leave the setting as is; otherwise, set to “PULSE”.

## Step 5

### Set the date and time

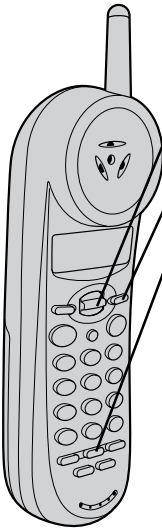

- 1 Press **(PGM)**.
- 2 Raise or lower the Jog lever until "DATE/TIME" appears on the display.
- 3 Press **(SELECT)**.



- 4 Set the correct month using the Jog lever, then press **(SELECT)**.
- 5 Set the correct day, hour (1 to 12) and minute (00 to 59) as in step 4.
- 6 Choose "AM" or "PM" using the Jog lever, then press **(PGM)**.

You will hear a long confirmation beep and the phone starts counting time.

#### Tip

You may press **(SELECT)** instead of pressing **(PGM)** in step 6.

# Identifying the parts

Refer to the pages indicated in parentheses for details.

## Base Phone

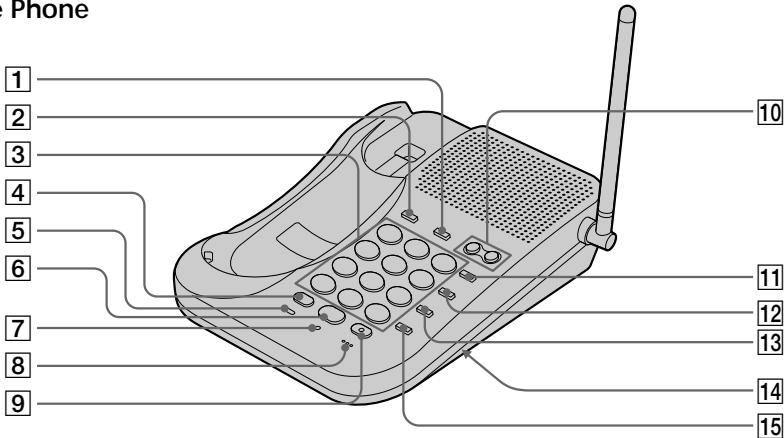

- 1** **VOICE MAIL lamp** (p. 47)  
Flashes when you have messages.
- 2** **NEW CALL lamp** (p. 39)  
Flashes when there is a “NEW” data in the Caller ID list.
- 3** **Dialing keys**
- 4** **HOLD button** (p. 20, 33)  
Press to put a call on hold.
- 5** **CHARGE lamp** (p. 9, 19)  
Lights while the battery is being charged.
- 6** **SPEAKERPHONE button** (p. 20, 22)  
Press to make or receive a call with the base phone.  
This button keeps lit until you are done talking.
- 7** **LINE lamp** (p. 18, 22)  
Lights when the handset is in use.
- 8** **MIC (microphone)**
- 9** **INTERCOM button/lamp** (p. 36)  
Used to make an intercom call.  
The INTERCOM lamp on this button keeps lit until you are done talking.
- 10** **VOLUME +/- buttons** (p. 20, 22)  
Adjusts the speaker volume.
- 11** **SPEED DIAL button** (p. 25)  
Used to make a call with speed dialing.
- 12** **PGM (Program) button** (p. 25)  
Used to store numbers for speed dialing.
- 13** **REDIAL/PAUSE button** (p. 21)  
Redials the last number called/  
inserts a pause in the dialing sequence.
- 14** **RINGER switch** (p. 32)  
Used to adjust the ringer volume level of the base phone.
- 15** **CALL WAITING/FLASH button** (p. 20)  
Switches to a second call if you have “call waiting” service.

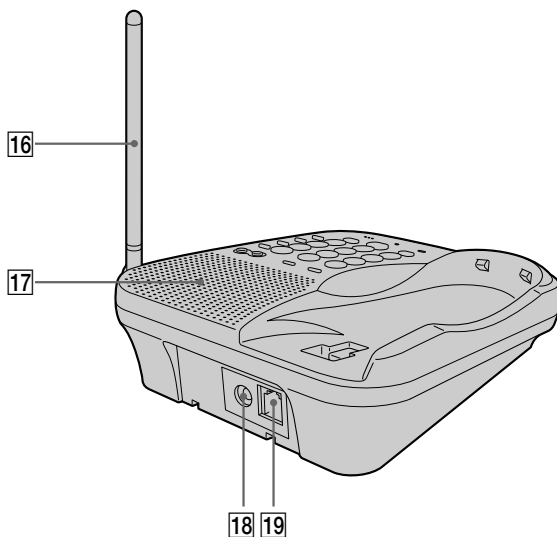

- 16** Antenna (p. 7, 49)
- 17** Speaker (p. 20, 22)
- 18** DC IN 9V jack (p. 7)
- 19** LINE (telephone line) jack (p. 7)

**continued**

## Identifying the parts (continued)

### Handset

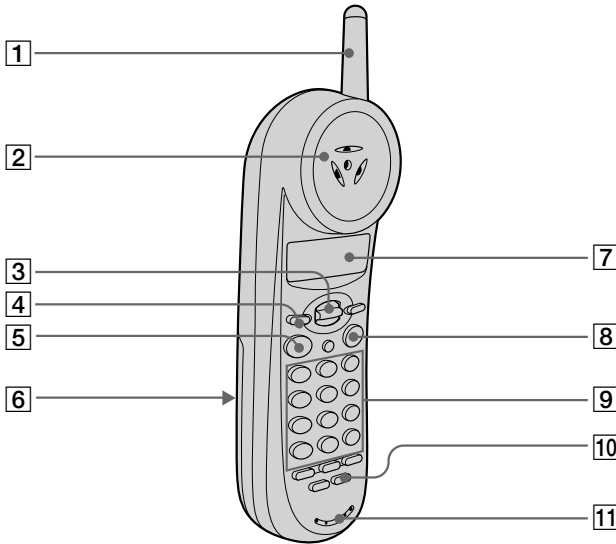

**1** Antenna

**2** Speaker

**3** Jog lever (p. 11, 23, 30, 31, 39)

**4** HOLD button (p. 18, 34)

Press to put a call on hold.

**5** TALK button (p. 18, 21, 22, 24, 33, 37)

Lets you make or receive a call.

**6** Battery compartment (p. 9)

**7** Display (p. 11, 38)

**8** OFF button (p. 18, 22, 33, 35)

Allows you to disconnect the call.

**9** Dialing keys

**10** CHANNEL button (p. 18)

Press to select a better channel.

**11** Microphone

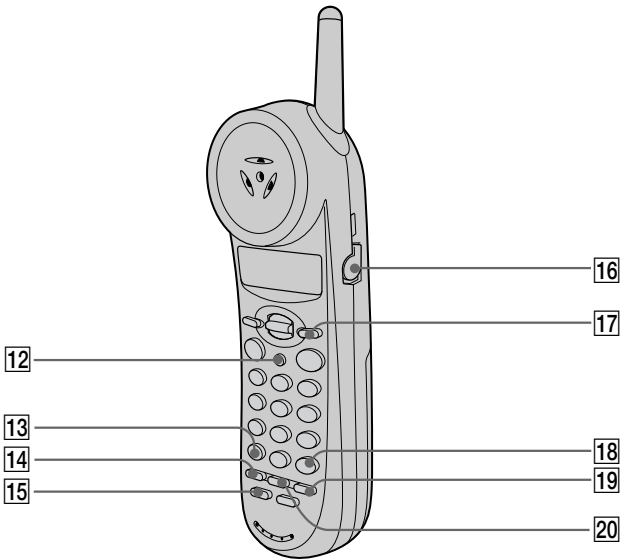

**12 FLASH button** (p. 18, 46)

Switches to a second call if you have “call waiting” service, or lets you make a new call.

**13 \* TONE button** (p. 18)

Allows you to switch temporarily to tone dialing.

**14 ONE-TOUCH button** (p. 23)

Used to make a call with one-touch dialing.

**15 INTERCOM button** (p. 35)

Used to make an intercom call.

**16**  (HEADSET) jack (p. 51)**17 SELECT button** (p. 11 – 13, 23, 27, 31, 40, 42)

Press to enter the selection and bring you to the next selection.

**18 # button** (p. 44)

Used to change the number of digits of the phone number in the Caller ID list.

**19 REDIAL/PAUSE button**  
(p. 21, 24, 26, 28)

Redials the last number called/ inserts a pause in the dialing sequence.

**20 PGM (Program) button**  
(p. 11 – 13, 23, 27, 31, 47)

Press to start the procedure for setting up the phone such as choosing the dialing mode.

Also used to store the setting to finish the procedure.

# Making calls

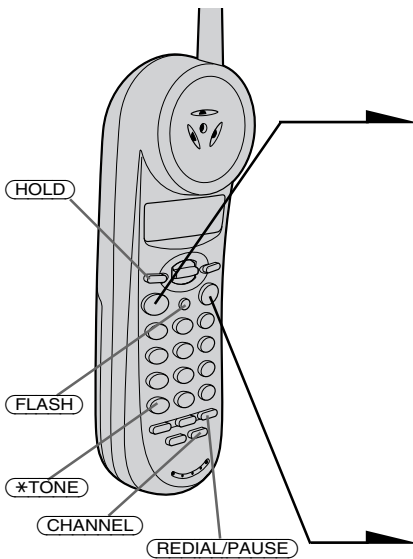

- 1 Pick up the handset from the base phone.
- 2 Press **TALK** and wait until "TALK" appears on the display. You will then hear a dial tone. The LINE lamp on the base phone lights up. If "NO CONNECT" appears on the display, move closer to the base phone.
- 3 Dial the phone number.
- 4 When you're done talking, press **OFF** or replace the handset on the base phone. The display and the LINE lamp on the base phone go off.

## Additional tasks

To	Do this
Select a better channel	Press <b>CHANNEL</b> .
Adjust the handset volume	Raise or lower the Jog lever to set the handset volume.
Put a call on hold	Press <b>HOLD</b> . Press <b>HOLD</b> or <b>TALK</b> to resume the conversation.
Switch to tone dialing temporarily	Press <b>*TONE</b> after you're connected. "t" appears on the display. The line will remain in tone dialing until disconnected.
Switch to another call ("call waiting" service*)	Press <b>FLASH</b> . Press <b>FLASH</b> again to return to the first caller.
Turn on/off the ringer of the handset	See page 31.

\* You need to subscribe to the service from your telephone company.

### Notes

- When you increase the sound volume, in some cases the back ground noise may be increased as well. You should adjust the volume accordingly.
- If another call comes in by “call waiting” service while conversing with an outside caller, you will hear two short beeps.

### Tip

To inform you of an incoming call, the display shows “\*\* RINGING \*\*” when ringing.

### If the battery becomes weak during a call

The handset will beep every few seconds and  and “BATTERY LOW” appears on the display. Finish your call and charge the battery pack.

### For optimum performance, charge the battery for a full 12 hours.

Note that during the first 10 - 15 minutes of charging, the phone will be inactive, i.e., unable to make or receive a call. At this time, “NEEDS RECHARGING” appears on the display and the CHARGE lamp flashes.

After this initial 10 - 15 minutes, you **may** be able to use the phone, but the battery duration will be **very short**; thus it is recommended that you **fully charge** the battery before the next usage.

**continued**

## Making calls (continued)

### Making calls through the speakerphone

Press **(SPEAKERPHONE)** on the base phone.  
The **SPEAKERPHONE** button and the  
**LINE** lamp light up.

Dial the phone number.

When you are done talking, press  
**(SPEAKERPHONE)** again.

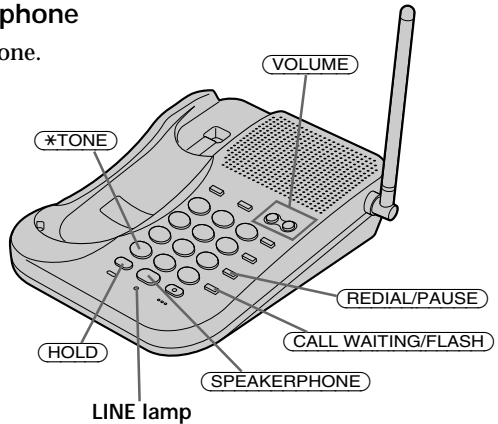

### Additional tasks

To	Do this
Put a call on hold	Press <b>(HOLD)</b> . The <b>LINE</b> lamp flashes slowly. Press <b>(SPEAKERPHONE)</b> to resume the conversation.
Adjust the speaker volume	Press <b>(VOLUME)</b> <b>(+)</b> or <b>(-)</b> .
Switch to tone dialing temporarily	Press <b>(*TONE)</b> while using the telephone after you're connected. The line remains in tone dialing until disconnected.
Switch to another call ("call waiting" service*)	Press <b>(CALL WAITING/FLASH)</b> to access the flash function. Press <b>(CALL WAITING/FLASH)</b> again to return to the first caller.

\* You need to subscribe to the service from your telephone company.

### To obtain the best speakerphone performance

- You may not be able to hear the other party's voice in a noisy place. Therefore, use the speakerphone in a quiet room.
- Do not bring your hand or other object too close to the microphone or you will hear a shrill noise ("feedback").
- When the speaker volume is loud, or the telephone has been placed close to a wall, you may find that the volume drops suddenly. This is due to a circuit in the telephone designed to protect against feedback. In such cases, lower the speaker volume slightly.

## Redialing

### On the handset

- 1 Press **TALK** and wait until “TALK” appears on the display.  
The LINE lamp on the base phone lights up.
- 2 Press **REDIAL/PAUSE** to redial the last number dialed.

#### Note

If the number exceeds 32 digits or if it is erased, five short error beeps will alert you that the number cannot be redialed.

### To check the phone number before redialing

While the handset is not in use, press **REDIAL/PAUSE**.

The last number dialed is displayed for five seconds.

To dial the number, press **TALK** while the number is displayed.

#### Note

The number will not be displayed if the last number dialed exceeds 32 digits or if it is erased.

### To erase the last phone number dialed

While the handset is not in use, press **REDIAL/PAUSE** twice within five seconds.

The number will be erased from the memory, and you will hear a long confirmation beep.

### On the base phone

- 1 Press **SPEAKERPHONE**.  
The SPEAKERPHONE button lights up.
- 2 Press **REDIAL/PAUSE** to redial the number last dialed.

#### Note

If the number last dialed exceeds 16 digits, only the first 16 digits are dialed.

# Receiving calls

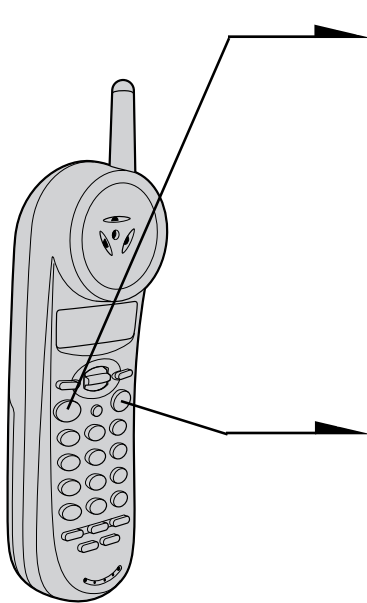

- 1** When you hear the phone ring,
  - press **TALK** (or any key except **OFF**).or
  - pick up the handset from the base phone if it is placed on the base phone.“TALK” appears on the display.  
The LINE lamp on the base phone lights up.

- 2** When you are done talking, press **OFF** or replace the handset on the base phone.  
The display and the LINE lamp on the base phone go off.

## Receiving calls through the speakerphone

When the phone rings, press **SPEAKERPHONE** on the base phone.

The **SPEAKERPHONE** button and the LINE lamp light up.

To adjust the speaker volume, press **VOLUME** **+** or **-**.

When you are done talking, press **SPEAKERPHONE** again.

To obtain the best speakerphone performance, see page 20.

To adjust the ringer volume, see page 32.

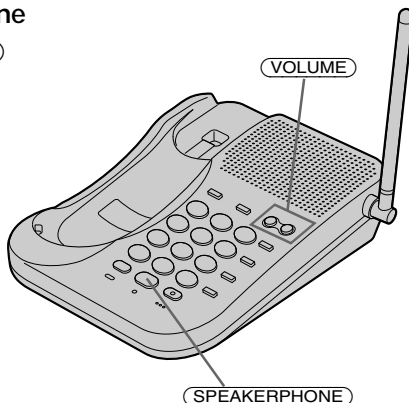

## If you have subscribed to the Caller ID service

The caller's number and/or name appears on the display when you receive a call (see page 38). If you receive a call by someone you do not want to answer, press **OFF** to stop the ringer.

# One-touch dialing

You can dial with one touch of the key by storing a phone number on the one-touch dialing button. When making long distance calls, it is convenient if the access number of the long distance call service provider is stored beforehand to one-touch dialing button.

## Storing phone number

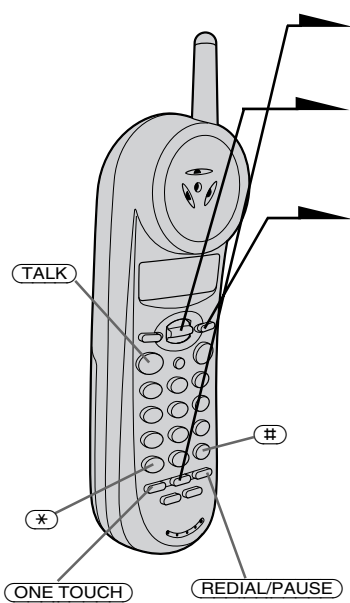

- 1 Press **PGM**.
- 2 Display "SET ONE TOUCH" using the Jog lever.

- 3 Press **SELECT**.  
If a number is stored, it appears on the display.  
To store a new number, lower the Jog lever several times to erase it.

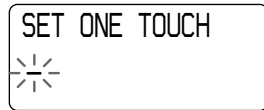

- 4 Enter the phone number.  
You can enter up to 16 digits, including a tone and a pause, each of which is counted as one digit.

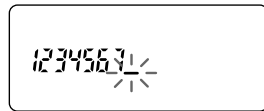

- 5 Press **PGM**.  
You will hear a long confirmation beep, and the number is stored.  
The display goes off.

continued

---

## One-touch dialing (continued)

### Note

Do not allow more than 20 seconds to elapse between each step of the procedure.

### Tips

- You may press **(ONE TOUCH)** instead of doing steps 2 and 3.
- The entered phone number **(\*)** and **(#)** are displayed as “\*” and “#” respectively in step 4.
- You may press **(SELECT)** instead of pressing **(PGM)** in step 5.

### To store a number to be dialed via Private Branch Exchange (PBX)

Before entering a phone number in step 4 above, do as follows:

- 1 Enter the outside line access digit (e.g., 9).
- 2 Press **(REDIAL/PAUSE)**.

## Making calls with one-touch dialing

- 1 Press **(TALK)** and wait until “TALK” appears on the display.
- 2 Press **(ONE TOUCH)**.

The phone number stored on the one-touch dialing button will appear on the display and will be dialed.

### Making Long Distance Calls with one-touch dialing

First of all, store the access number in “Storing phone number” above-mentioned steps, then do as follows:

- 1 Perform steps 1 and 2 in “Making calls with one-touch dialing” above.
- 2 Display “DIRECTORY” by pressing **(SELECT)**.
- 3 Display the name and phone number you want to call (see page 27), then press **(SELECT)** or **(TALK)**.

When you leave the Jog lever raised, or lowered, the names and phone numbers on the display scroll fast.

### To check the phone number before one-touch dialing

While the handset is not in use, press **(ONE TOUCH)**.

The number stored on the button appears on the display for 20 seconds. To dial the number, press **(TALK)** while the number is displayed.



# Speed dialing

You can dial with a touch of a few buttons by storing a phone number on a dialing key. You can store up to 10 different phone numbers on the base phone.

## Storing phone numbers on the base phone

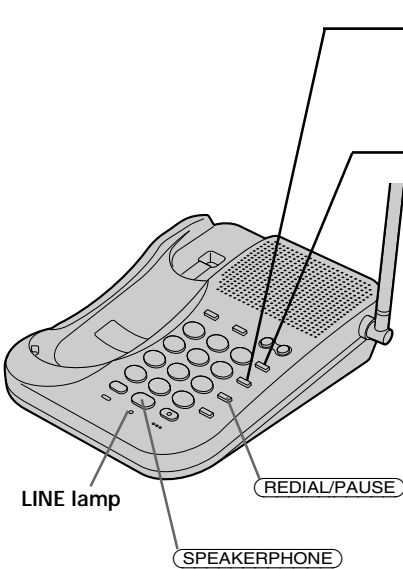

- 1** Press **PGM**.  
The **SPEAKERPHONE** button flashes.
- 2** Press **SPEED DIAL**.
- 3** Press one of the dialing keys (**0** to **9**) for the phone number to be stored.  
You will hear a confirmation beep.
- 4** Enter the phone number you want to store.  
You can enter up to 16 digits, including a tone and a pause, each of which is counted as one digit.
- 5** Press **PGM** again.  
You will hear another confirmation beep, and the number is stored.

### Notes

- In step 4, if you don't enter the phone number, the previously stored number will be erased.
- Do not allow more than 20 seconds to elapse between each step of the procedure.
- You cannot store phone numbers on the base phone while the handset is being used. The **LINE lamp** will light up to indicate this condition.

### Tips

- In step 4, if you enter a wrong number, press **PGM**, then start from the beginning.
- Use the supplied directory to write down what you have stored to the speed dialing numbers.

continued

---

## Speed dialing (continued)

### To store the previous number dialed

Press **REDIAL/PAUSE** directly after step 3 on the previous page, then go to step 5.

### To store a number to be dialed via Private Branch Exchange (PBX)

Before entering a phone number in step 4 on the previous page, do as follows:

- 1 Enter the outside line access digit (e.g. 9).
- 2 Press **REDIAL/PAUSE**.

### To change a stored number

Follow the steps 1 to 5 on the previous page. In step 4, enter a new phone number to overwrite the old one.

### To clear a number from memory

- 1 Press **PGM**.  
The **SPEAKERPHONE** button flashes.
- 2 Press **SPEED DIAL**.
- 3 Press one of the dialing keys (**0** to **9**) you want to clear.
- 4 Press **PGM** again.

## Making calls with speed dialing on the base phone

- 1 Press **SPEAKERPHONE**.  
The **SPEAKERPHONE** button lights up.
- 2 Press **SPEED DIAL**.
- 3 Enter the desired speed dialing number (**0** to **9**).  
The phone number stored in the speed dialing number will be dialed.

# Phone Directory

You can dial a number by scrolling through the Phone Directory, in which up to 50 phone numbers can be stored.

## Storing phone numbers and names

Example: to store “SONY” “123-4567”.

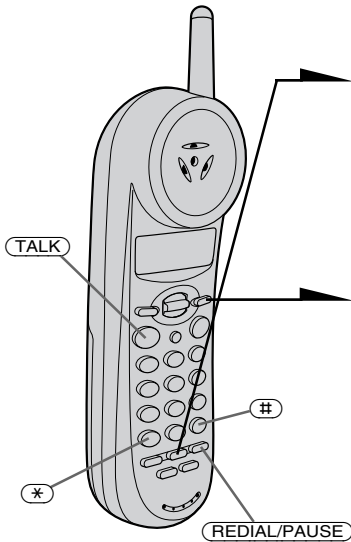

- 1 Press **(PGM)**.  
(Be sure not to press **(TALK)**.)
- 2 Display “DIRECTORY” using the Jog lever, then press **(SELECT)**.  
“ENTER NAME” appears.
- 3 Enter the name using the dialing keys. You can enter up to 15 characters.



Press a dialing key repeatedly until the desired character appears. (See the character table for details.)

Enter successive characters in the same way.

To enter two characters assigned to the same key, or to enter a “space”, raise the Jog lever to move the cursor to the right.

**Example:** to enter “SONY”, press **(7)** four times (S), press **(6)** three times (O), raise the Jog lever to move the cursor, press **(6)** twice (N), and press **(9)** three times (Y).

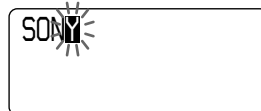

### Character table

Key	Character
①	1
②	A → B → C → 2
③	D → E → F → 3
④	G → H → I → 4
⑤	J → K → L → 5
⑥	M → N → O → 6
⑦	P → Q → R → S → 7
⑧	T → U → V → 8
⑨	W → X → Y → Z → 9
⑩	0
*	*
#	& → ' → , → - → . → #

continued

## Phone Directory (continued)

**4** Press **(SELECT)**.

“ENTER NUMBER” appears.

**5** Enter the phone number.

You can enter up to 16 digits, including a tone and a pause, each of which is counted as one digit.

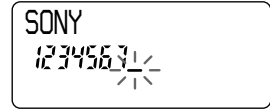

**6** Press **(PGM)**.

You will hear a long confirmation beep, and the name and the number are stored. The display goes off.

### Notes

- If you intend to save a 51st phone number, you will hear five short error beeps and “MEMORY FULL” will be displayed. You cannot store the phone number. To store another phone number, erase one of the stored phone numbers (see page 29).
- Do not allow more than 20 seconds to elapse between each step of the procedure.

### Tips

- If you have entered a wrong name or number in step 3 or 5, lower the Jog lever to erase it. Then enter the correct name or number.
- The entered phone number **(\*)** and **(#)** are displayed as “\*” and “#” respectively in step 5.

## To store a number to be dialed via Private Branch Exchange (PBX)

Before entering a phone number in step 5 above, do as follows:

- 1** Enter the outside line access digit (e.g., 9).
- 2** Press **(REDIAL/PAUSE)**.

## Changing a stored name and/or phone number

- 1** Display the name and phone number you want to change by doing steps 1 and 2 on page 30.

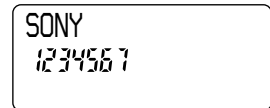

- 2** Press **(SELECT)**.



- 3** Make “EDIT” flash using the Jog lever, then press **(SELECT)**.

The cursor flashes at the last character of the name.

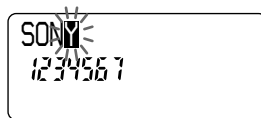

- 4** Lower the Jog lever to erase the characters and enter the new name.

If you want to change only the number, skip this step.

- 5** Press **(SELECT)**.

The cursor flashes at the last digit of the phone number.

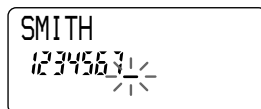

- 6** Lower the Jog lever to erase the number and enter the new number.

If you do not want to change the number, skip this step.

- 7** Press **(SELECT)**.

You will hear a long confirmation beep and the name and/or the number is changed.

## Erasing a memory location

- 1** Display the name and phone number you want to erase by doing steps 1 and 2 on page 30.

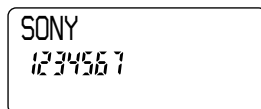

- 2** Press **(SELECT)**.

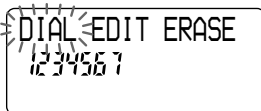

- 3** Make “ERASE” flash using the Jog lever, then press **(SELECT)**.

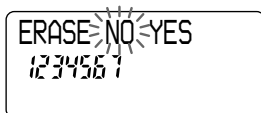

- 4** Make “YES” flash using the Jog lever, then press **(SELECT)**.

You hear a long confirmation beep and the memory location is erased.

continued

## Making calls from the Phone Directory

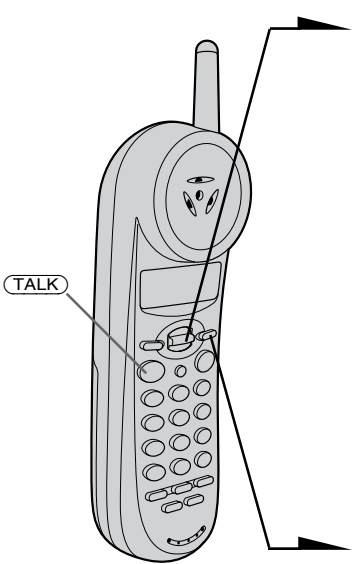

**1** Raise the Jog lever.  
“DIRECTORY” appears.

**2** Display the name and phone number you want to call.

To search in alphabetical order:  
Raise or lower the Jog lever.

To search by entering the initial character:  
Press the dialing key of the desired character, then lower the Jog lever.

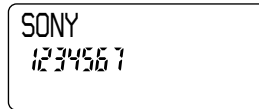

**3** Press **SELECT**.



**4** Press **SELECT** again.

The phone number will be dialed.

### Tip

You may press **TALK** to make a call instead of pressing **SELECT** in steps 3 and 4.

### About the search order

The names appear in the following order when you raise or lower the Jog lever.

- Alphabetical order: ABC...XYZ ↔ symbols ↔ \* ↔ # ↔ 0 - 9
- Initial character: To search for “SONY” for example, press **7** and then lower the Jog lever to search through the names starting with S.

# Setting the ringer type

You can select a ringer type of the handset from four types.

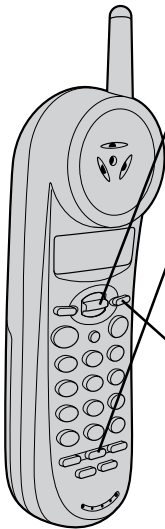

- 1 Press (PGM).
- 2 Display "RINGER" using the Jog lever.

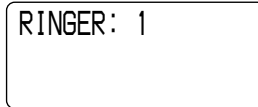

The current ringer type appears.

- 3 Press (SELECT).
- 4 Select a ringer type ("1" to "4") using the Jog lever.
- 5 Press (PGM).

You will hear the corresponding ringer tone.

## Tip

You may press (SELECT) instead of pressing (PGM) in step 5.

## Turning off the ringer of the handset

- 1 Perform steps 1 to 3 in "Setting the ringer type" above.
- 2 Select "OFF" using the Jog lever.
- 3 Press (PGM).

You will hear a long confirmation beep.

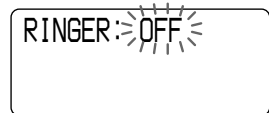

## Tip

You may press (SELECT) instead of pressing (PGM) in step 3.

## When "RINGER" is set to "RINGER OFF"

The handset won't ring. You can still make calls, and also receive calls if another telephone connected to the same line rings to inform you on incoming calls.

---

## Setting the ringer type (continued)

### To turn the ringer on again

Follow the instructions described in “Setting the ringer type” above.

## Adjusting the ringer volume level of the base phone

Set the RINGER switch on the base phone to HIGH or LOW. To turn the ringer off, set it to OFF.

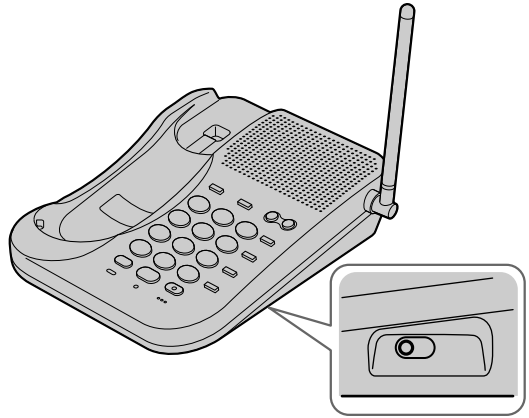

RINGER switch



# Switching the phones during a call

When you put a call on hold, you can return to the call on the other phone without disconnecting the call.

## To switch from the base phone to the handset

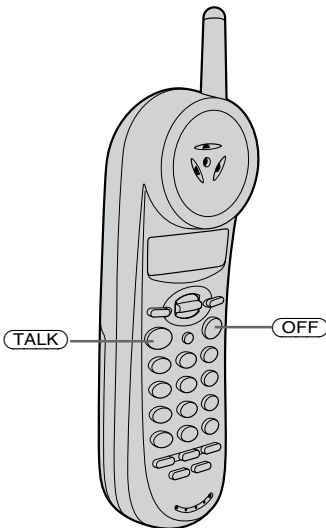
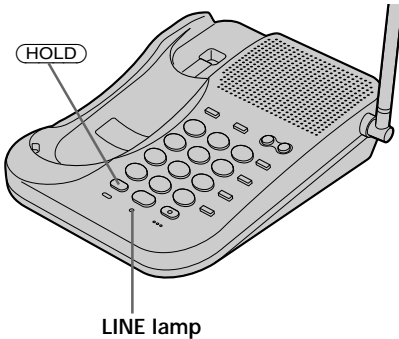

- 1** Press **(HOLD)** on the base phone.  
The LINE lamp on the base phone flashes slowly.
- 2** Press **(TALK)** or pick up the handset from the base phone.  
“TALK” appears on the display.  
The LINE lamp on the base phone lights up.
- 3** When you are done talking, press **(OFF)** or replace the handset to the base phone.  
The display and the LINE lamp on the base phone go off.

### Notes

- If you pick up the handset while talking through the speakerphone on the base phone, the call will be switched to the handset.
- If you do not press **(HOLD)** in step 1, and press **(TALK)** in step 2, you can make a three-way conversation (see “Having a three-way conference” on page 37).
- When the call is put on hold on the base phone, if you pick up the handset, the call will be switched to the handset.

---

## Switching the phones during a call (continued)

### To switch from the handset to the base phone

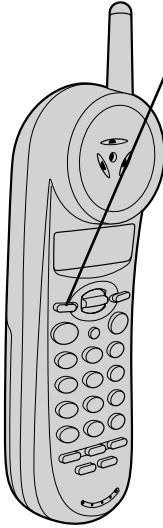

**1** Press **(HOLD)** on the handset.  
“HOLD” appears on the display.

**2** Press **(SPEAKERPHONE)**.  
The **SPEAKERPHONE** button and **LINE** lamp on the base phone lights up.

**3** When you are done talking, press **(SPEAKERPHONE)** again.

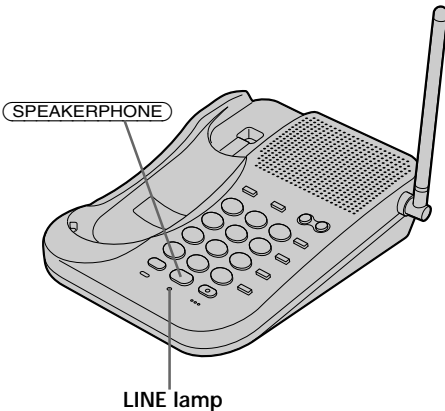

---

# Talking between the handset and the base phone (Intercom)

You can talk between the base phone and the handset. You can start the intercom from either phone.

## To talk from the handset to the base phone

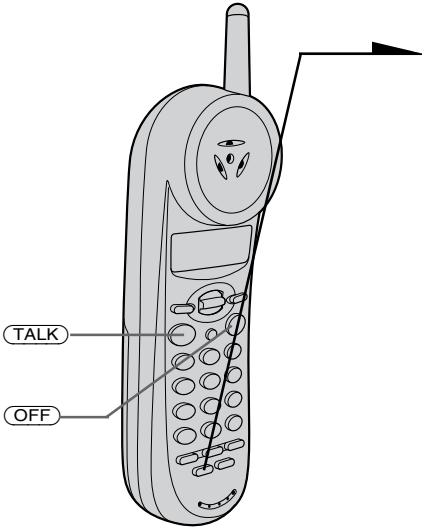

- 1** Press **INTERCOM** on the handset.  
After the base phone rings once, you will be connected automatically.  
When a person at the base phone answers, you can talk. The INTERCOM lamp on the base phone lights up.

- 2** When you are done talking or if no one answers the phone, press **OFF**.

**continued**

---

## Talking between the handset and the base phone (Intercom) (continued)

### To talk from the base phone to the handset

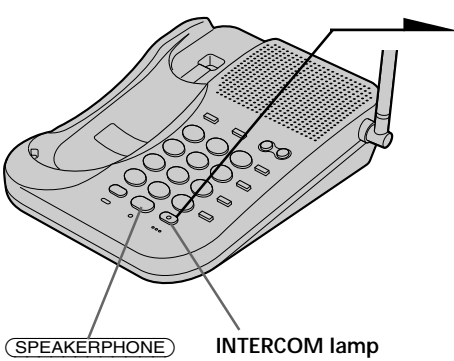

**1** Press **INTERCOM** on the base phone.

The handset rings.

When the person at the handset presses **INTERCOM**, you can talk.

The INTERCOM lamp on the base phone lights up.

**2** When you are done talking or if no one answers the phone, press **INTERCOM** again.

#### Notes

- The call to the handset will stop automatically after a minute.
- If there is an incoming call while on the intercom, the ringer will ring on both the base phone and the handset. To answer the call, press **TALK** on the handset or **SPEAKERPHONE** on the base phone. The intercom will be disconnected automatically, and the call will be connected to the unit whose button you have pressed.

# Having a three-way conference

The handset and the base phone operate like two extensions on the same line. Both phones can operate at the same time, so that you, the outside caller, and the person at the other phone can engage in a three-way conversation.

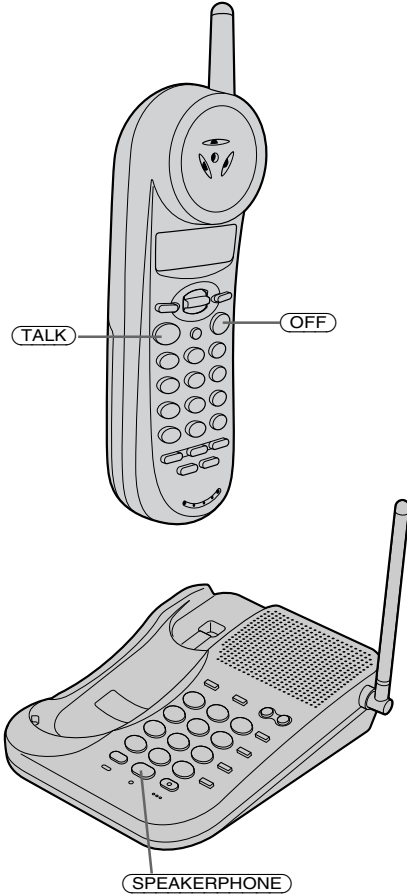

## To join the phone conversation

Press **TALK**.

“TALK” appears on the display.

If you are at the base phone, simply press **SPEAKERPHONE**.

The **SPEAKERPHONE** button on the base phone lights up.

## When you are done talking

Press **OFF** on the handset (or press **SPEAKERPHONE** if you are at the base phone).

### Tip

While talking through the speakerphone on the base phone, if you pick up the handset, the conversation will be continued between the handset and outside caller.

# Understanding the Caller ID service

Caller ID allows the caller's phone number to be shown on the display before the call is answered. In order to use this feature, you must first subscribe to the Caller ID service. The name of this service may vary depending on your telephone company.

## When you receive a call

The phone number appears on the display with the date and time as shown in the following example.

If your Caller ID service includes the caller name service, the caller's name also appears on the display (up to 15 letters).

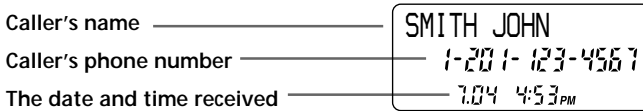

When you answer the call, the Caller ID display changes to the "TALK" display.

### Note

If the call is from an office which uses multiple lines, the displayed phone number may not match the number you use to call the extension.

# Looking at the Caller ID list

The phone stores the data of the last 50 calls received. It keeps track of all calls received; even if they were not answered.

## Viewing the Caller ID list

You can look through the Caller ID list to check the phone number and/or name of the calls received.

While the handset is not in use the display shows the number of “NEW” (calls which you have not viewed) and “OLD” (calls which you have viewed) calls. If there is a “NEW” data, the NEW CALL lamp of the base phone flashes.

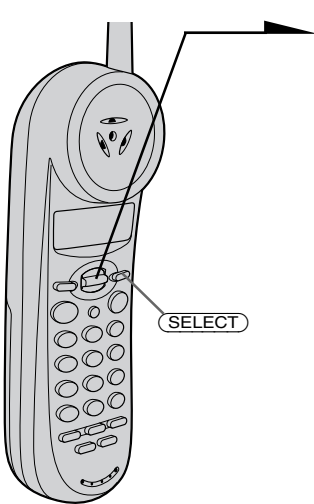
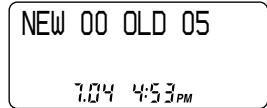

- 1** Lower the Jog lever. Data for the newest call appears for 20 seconds.
- 2** Lower the Jog lever to display older data or raise to display newer data.

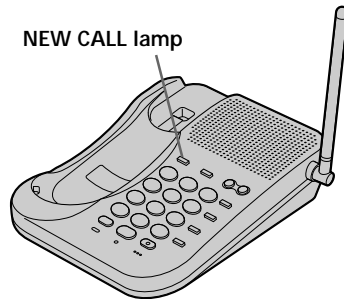

### Note

If a 51st call is received, the oldest data is automatically erased.

## Looking at the Caller ID list (continued)

### About the "\*" mark

"\*" appears if there are two or more calls in a row from the same phone number. The older data will be replaced by the new data, so the calls are counted as only one call.

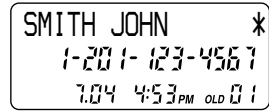

### Erasing data from the Caller ID list

Old data will be erased automatically when a 51st call comes in, but you can also manually erase unnecessary data one by one or erase the entire list.

#### To erase the phone number one by one

**1** Display the phone number you want to erase from the Caller ID list (see page 39).

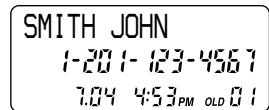

**2** Press **(SELECT)**.

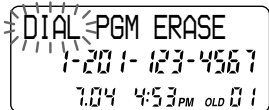

**3** Make "ERASE" flash using the Jog lever, then press **(SELECT)**.

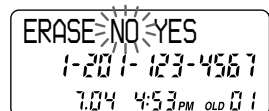

**4** Make "YES" flash using the Jog lever, then press **(SELECT)**.

You will hear a long confirmation beep and the data is erased.



## To erase the entire list at once

You can erase the entire list at once only when all the data has become "OLD" data. If there is any "NEW" data, you cannot erase the entire list.

- 1 Display any Caller ID data.

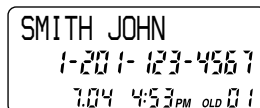

- 2 Press **(SELECT)**.

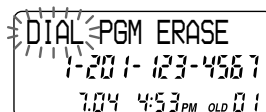

- 3 Make "ERASE" flash using the Jog lever, then press **(SELECT)**.

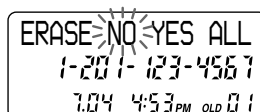

- 4 Make "ALL" flash using the Jog lever, then press **(SELECT)**.

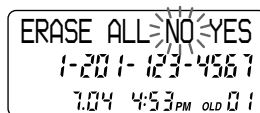

- 5 Make "YES" flash using the Jog lever, then press **(SELECT)**.

You will hear a long confirmation beep and the entire list is erased.

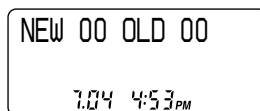

# Using the Caller ID list

By using the Caller ID list, you can call back a phone number from the Caller ID list easily, or store numbers from the Caller ID list into the Phone Directory.

## Calling back a number from the Caller ID list

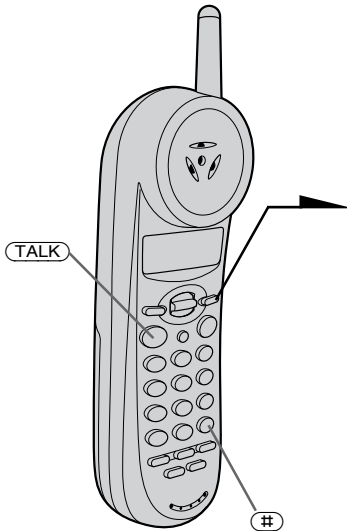

- 1 Display the phone number you want to call from the Caller ID list (see page 39).

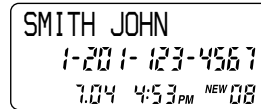

- 2 Confirm the number and press **SELECT**.

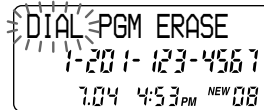

- 3 Make "DIAL" flash using the Jog lever, then press **SELECT**.  
The phone automatically dials the displayed number.

### Notes

- If the number displayed in step 1 is not the one you should call back, you can change the number of digits of the phone number (see page 44).
- If the phone is connected to a Private Branch Exchange (PBX), you may not be able to call back from the Caller ID list because an outside line access digit is necessary.

### Tip

You may press **TALK** to make a call instead of pressing **SELECT** in steps 2 and 3.

## Storing a number of the Caller ID list into the Phone Directory

- 1** Display the name and phone number you want to store from the Caller ID list (see page 39).

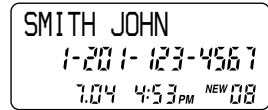

- 2** Confirm the number and press **(SELECT)**.

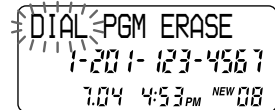

- 3** Make "PGM" flash using the Jog lever, then press **(SELECT)**.

The cursor flashes at the end of the name.

Enter or change the name, if necessary (see page 28).

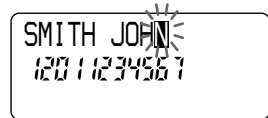

- 4** Press **(SELECT)**.

The cursor flashes at the right of the phone number.

Enter or change the phone number, if necessary (see pages 28 and 29).

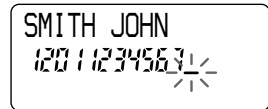

- 5** Press **(SELECT)** again.

You will hear a long confirmation beep and the name and number are stored.

### Notes

- Do not allow more than 20 seconds to elapse between each step of the procedure.
- If the number displayed in step 1 is not the one you should store, you can change the number of digits of the phone number (See page 44).
- If the phone is connected to a Private Branch Exchange (PBX), you may need to add an outside line access digit.

continued

## Using the Caller ID list (continued)

### To change the number of digits of the phone number

If the number of digits of the phone number in the Caller ID list is different from the actual phone number, you need to adjust the number of digits of the phone number to call back or store into the Phone Directory.

- 1 While the phone number from the Caller ID list is displayed, press **(#)** repeatedly until the phone number with the correct number of digits appears on the display.

Each time you press **(#)**, the number of digits changes as follows.

When you receive the 11 digits phone number

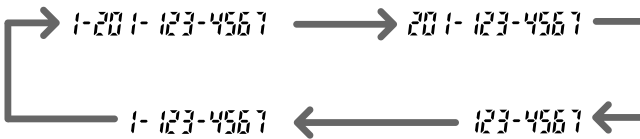

When you receive the 10 digits phone number

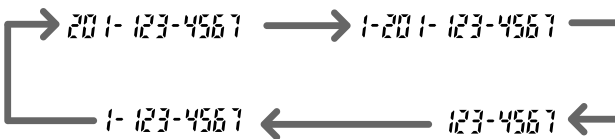

---

When you receive the 8 digits phone number

2 1234567 ← → 12 1234567

When you receive the 7 digits phone number

123-4567 ← → 1- 123-4567

**2** Continue the operation to call back or store the phone number with the correct number of digits (see pages 42 and 43).

**Notes**

- The number of digits of the phone number does not change even if you press **(#)** when you receive the phone number of 6 digits or less.
- You need to adjust the number of digits each time you call back from the Caller ID list as the changes to the Caller ID data is not stored in memory.
- You may not be able to change the number of digits depending on the Caller ID data.

---

# Using “Caller ID with call waiting” service

This telephone is compatible with the “Caller ID with call waiting” service. Make sure that your telephone company offers this service.

Like the basic Caller ID service, you need to subscribe to “Caller ID with call waiting” in order to use this service.

Even though you may have already subscribed to “Caller ID” and “call waiting” as two separate services, you need to request a subscription to “Caller ID with call waiting” as a single service.

This is a new service that combines the two services.

Even though you now have a “Caller ID with call waiting” compatible phone, unless you subscribe to the combined “Caller ID with call waiting” service, you will not be able to see the name and number of the second caller.

When a new call comes in while you are talking, you hear two short beeps. The caller’s name and/or phone number of the new call appears on the display for about 20 seconds.

## To switch to another caller

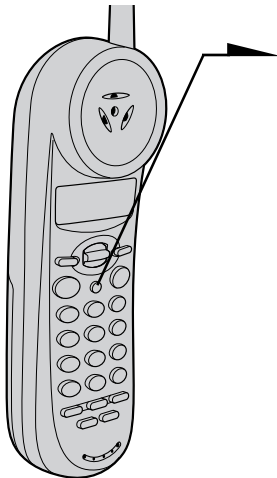

- 1** To switch to the new caller, press **FLASH**.
- 2** To switch back to the first caller, press **FLASH** again.

# Using voice mail service

If you subscribe to your telephone company's message service which includes this feature, the display will show that you have messages waiting to be retrieved.

## If you have messages

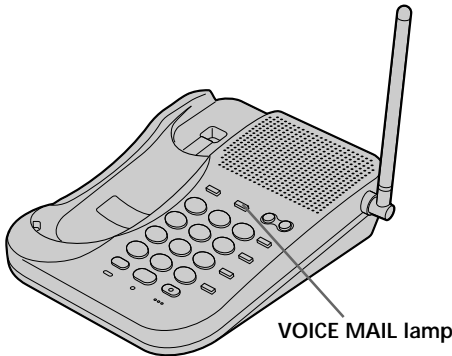

"MESSAGES WAITING" appears on the display, and the VOICE MAIL lamp on the base phone flashes.

The display and the VOICE MAIL lamp go off when you retrieve your messages.

### Note

You cannot use this feature, if you have not subscribed to your telephone company's message service. For details on the availability of this service, please ask your telephone company.

## If the VOICE MAIL lamp remains flashing

If this lamp does not go off (e.g. When you retrieve your messages with other phones), you can go off the lamp manually.

## To go off the VOICE MAIL lamp

- 1 Press **(PGM)** on the handset.
- 2 Display "MESSAGES WAITING" using the Jog lever, then press **(SELECT)**.
- 3 Make "YES" flash using the Jog lever, then press **(PGM)**.

The VOICE MAIL lamp on the base unit goes off, and you will hear a long confirmation beep.

### Tip

You may press **(SELECT)** to go off the VOICE MAIL lamp instead of pressing **(PGM)** in step 3.



---

## Using voice mail service (continued)

### **If you move or change your telephone company**

If you turn off the base phone, it is reset and either FSK or stutter dial tone is automatically selected according to the voice mail service you are using.



# Mounting the base phone on a wall

1

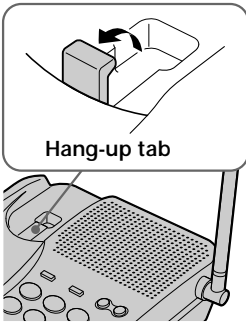

1

Raise the hang up tab.

2

Plug the telephone line cord to the LINE jack and the AC power adaptor to the DC IN 9V jack, and hook the cords.

2

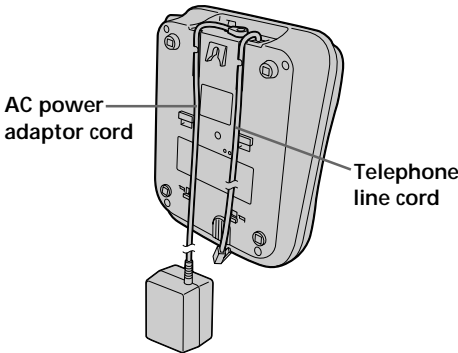

3

Attach the wall bracket to the center of the base phone.

Align the  $\Delta$  marks of the wall bracket with those of the base phone.

3

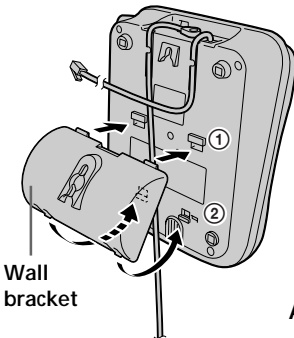

4

Plug the telephone line cord to the telephone outlet, and hook the base phone to the wall plate.

5

Plug the AC power adaptor to an AC outlet. Then raise the antenna so that it points towards the ceiling.

4,5

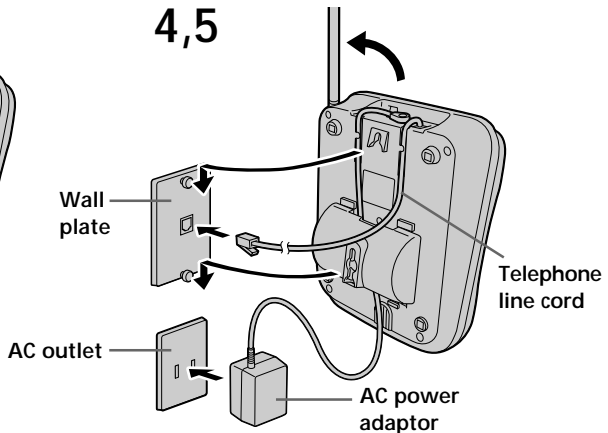

**Tip**

To remove the wall bracket, press the lower tabs.

# Carrying the handset by the belt clip

You can hang the handset on the belt by attaching the belt clip to the handset.

## Attaching the belt clip

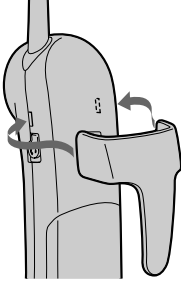

Press the belt clip to the handset. Make sure that the side tabs click and go into the holes on the sides of the handset.

### Note

To prevent the handset from dropping, make sure that each tab is completely inserted.

## Detaching the belt clip

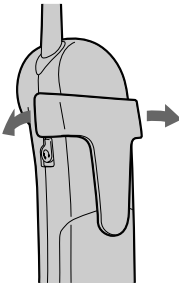

While pressing the back of the belt clip, pull the sides one by one until the tabs come off from the holes.

### Note

Remove the belt clip carefully to avoid breaking your fingernails.

## Using the headset

You can talk on the cordless handset without using your hands by connecting a headset (optional) to the (HEADSET) jack on the handset.

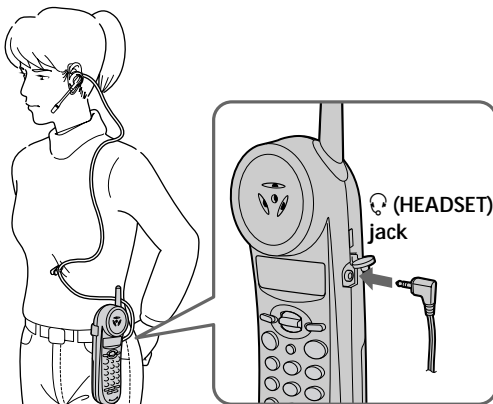

# Notes on power sources

## On battery pack

- Store the battery pack at a temperature between 41°F (5°C) and 95°F (35°C) for best performance.
- If you do not use the handset for a long period of time, remove the battery pack after charging for more than 12 hours. This maintains battery life.

### On power failure

During a power interruption, you cannot make or receive calls.

## For the customers in the USA

### RECYCLING NICKEL-CADMIUM BATTERIES

Nickel-Cadmium batteries are recyclable. You can help preserve our environment by returning your unwanted batteries to your nearest point for collection, recycling or proper disposal.



Note: In some areas the disposal of nickel-cadmium batteries in household or business trash may be prohibited.

RBRC (Rechargeable Battery Recycling Corporation) advises you about spent battery collection by the following phone number.

Call toll free number: 1-800-822-8837  
(United States and Canada only)

Caution: Do not handle damaged or leaking nickel-cadmium batteries.

---

# Maintenance

- Clean the cabinets with a soft cloth slightly moistened with water or a mild detergent solution. Do not use any type of abrasive pad, scouring powder or solvent such as alcohol or benzine as they may damage the finish of the cabinet.
- If the charge terminals of the base phone and handset are soiled, wipe them with a soft cloth.

If you have any questions or problems concerning your phone, please consult your nearest Sony dealer.

# Troubleshooting

If you've experienced any of the following difficulties while using your phone, use this troubleshooting to help you remedy the problem. Should any problem persist, consult your nearest Sony dealer.

	Symptom	Remedy
Making calls	You hear five short error beeps when you press <b>TALK</b> .	<ul style="list-style-type: none"> <li>• Make sure you set up the base phone correctly (page 6).</li> <li>• Move the handset closer to the base phone.</li> </ul>
	You hear no dial tone.	<ul style="list-style-type: none"> <li>• Make sure the telephone line cord is securely connected to the telephone outlet.</li> <li>• Make sure the battery is fully charged (page 9).</li> </ul>
	The phone does not connect at all, even though the number you dial is correct.	<ul style="list-style-type: none"> <li>• Make sure the dialing mode is set correctly (page 12).</li> <li>• Before dialing, make sure you hear a dial tone.</li> </ul>
	The phone does not redial correctly.	<ul style="list-style-type: none"> <li>• Make sure the last dialed number is really the one you want to dial.</li> </ul>
	You hear five short error beeps when you try to redial on the handset.	<ul style="list-style-type: none"> <li>• The number you last dialed exceeds 32 digits (including the tone and pause digits if used).</li> <li>• The number you last dialed is erased.</li> </ul>
	The base phone does not redial correctly.	<ul style="list-style-type: none"> <li>• Make sure the last dialed number is really the one you want to dial.</li> <li>• The number you last dialed exceeds 16 digits.</li> </ul>
Receiving calls	You cannot perform the redial operations (redialing, checking and erasing the phone number), and "NO CONNECT" appears on the display.	<ul style="list-style-type: none"> <li>• Move the handset closer to the base phone and perform the redial operations again.</li> </ul>
	The handset does not ring.	<ul style="list-style-type: none"> <li>• Make sure the ringer is turned on.</li> <li>• The battery may be weak. Charge the battery for more than 12 hours (page 9).</li> <li>• Make sure you set up the base phone correctly (page 6).</li> <li>• Move the handset closer to the base phone.</li> </ul>
	"NO LINE" appears on the display.	<ul style="list-style-type: none"> <li>• Make sure the telephone line cord is securely connected to the telephone outlet.</li> </ul>

	Symptom	Remedy
During conversation	You hear interference during conversation.	<ul style="list-style-type: none"> <li>• Move the handset closer to the base phone.</li> <li>• Place the base phone away from noise sources (page 6).</li> <li>• Press <b>(CHANNEL)</b> for a channel that gives better reception.</li> </ul>
	Your conversation is muted and “NO CONNECT” appear on the display.	<ul style="list-style-type: none"> <li>• This is the out-of-range alarm. Move the handset closer to the base phone within one minute.</li> </ul>
	You hear a beep every three seconds and  and “BATTERY LOW” appears on the display.	<ul style="list-style-type: none"> <li>• The battery may be weak. Charge the battery for more than 12 hours (page 9).</li> </ul>
	You cannot use call waiting service.	<ul style="list-style-type: none"> <li>• Make sure you have subscribed to call waiting service.</li> <li>• The setting of the FLASH TYPE may have been changed. Check the setting and correct it if changed by following the steps below.               <ol style="list-style-type: none"> <li>1 Press <b>(PGM)</b>.</li> <li>2 Display “FLASH TYPE:” using the Jog lever.</li> <li>3 If the value of the FLASH TYPE is not 3, press <b>(SELECT)</b> then display “3” using the Jog lever.</li> <li>4 Press <b>(PGM)</b>.</li> </ol> </li> </ul>
Speed dialing	You cannot store a speed dialing number.	<ul style="list-style-type: none"> <li>• Make sure you follow the procedure in storing the number correctly (page 25).</li> <li>• When the handset is in use, you cannot store a speed dialing number on the base phone.</li> <li>• When you hear four short beeps, move the handset closer to the base phone, or make sure you set up the base phone correctly.</li> </ul>
	You cannot make a speed dialing call.	<ul style="list-style-type: none"> <li>• You pressed the number button to which no phone number has been stored.</li> </ul>
	Speed dialing is incorrect.	<ul style="list-style-type: none"> <li>• Store a correct number (page 25).</li> </ul>
Phone Directory	You hear five short error beeps and cannot store a number in the Phone Directory.	<ul style="list-style-type: none"> <li>• Make sure you follow the procedure in storing the number correctly (page 27).</li> <li>• Make sure the number (including the tone and pause digits) does not exceed 16 digits.</li> </ul>
	Phone Directory dialing is incorrect.	<ul style="list-style-type: none"> <li>• Store a correct number (page 27).</li> </ul>
Intercom	The handset does not ring when calling from the base phone.	<ul style="list-style-type: none"> <li>• The handset may be engaged in conversation.</li> <li>• The battery may be weak. Charge the battery for more than 12 hours (page 9).</li> <li>• Move the handset closer to the base phone.</li> <li>• Place the base phone away from noise sources (page 6).</li> </ul>

## Troubleshooting (continued)

	Symptom	Remedy
Caller ID	The caller's name and/or phone number does not appear on the display.	<ul style="list-style-type: none"> <li>• Make sure you have subscribed to Caller ID service.</li> <li>• Caller ID service may not work when the phone is connected to a Private Branch Exchange (PBX).</li> <li>• You answered the call while “** RINGING **” was displayed. Be sure to answer after the Caller ID data is displayed.</li> </ul>
	The caller's name and/or phone number does not appear on the display during call waiting.	<ul style="list-style-type: none"> <li>• Make sure you have subscribed to “Caller ID with call waiting” service (page 46).</li> <li>• Make sure nobody is talking with another phone on the same telephone line.</li> </ul>
	You cannot dial the number from the Caller ID list.	<ul style="list-style-type: none"> <li>• You may need to change the number of digits of the phone number (page 44).</li> <li>• This function may not work when the phone is connected to a Private Branch Exchange (PBX).</li> </ul>
	You cannot use voice mail service.	<ul style="list-style-type: none"> <li>• Make sure you have subscribed to voice mail service.</li> <li>• If you move or change your telephone company, reset this phone.</li> </ul>
Power source/battery	The CHARGE lamp does not light up when you place the handset to charge.	<ul style="list-style-type: none"> <li>• Wipe the charge terminals of the base phone and the handset with a soft cloth for better contact of the charge terminals.</li> <li>• Make sure the handset is placed on the base phone properly.</li> </ul>
	The CHARGE lamp flashes.	<ul style="list-style-type: none"> <li>• The battery is empty. Charge the battery for more than 12 hours (page 9).</li> </ul>
	The battery duration is short.	<ul style="list-style-type: none"> <li>• The battery pack was charged less than 12 hours (due to power failure, etc.).</li> <li>• The usage life of the battery has expired and needs replacement.</li> </ul>



---

# Specifications

## General

### Frequency band

900 MHz ISM bands

### Operating channel

10 channels

### Dial signal

Tone, 10 PPS (pulse) selectable

### Supplied accessories

AC power adaptor AC-T122

Telephone line cord

Rechargeable battery pack BP-T18

Wall bracket

Directory

## Handset

### Power source

Rechargeable battery pack BP-T18

### Battery life

Standby: Approx. 7 days

Talk: Approx. 7 hours

### Dimensions

Approx. 2 1/4 x 1 7/8 x 7 1/4 inches (w/h/d),  
antenna excluded

(approx. 55 x 47 x 183 mm)

Antenna: Approx. 1 3/8 inches

(approx. 34 mm)

### Mass

Approx. 7.7 oz (approx. 220 g), battery  
included

## Base phone

### Power source

DC 9V from AC power adaptor AC-T122

### Battery charging time

Approx. 12 hours

### Dimensions

Approx. 7 x 2 1/4 x 7 1/2 inches (w/h/d),  
antenna excluded

(approx. 175 x 57 x 190 mm)

Antenna: Approx. 6 1/8 inches

(approx. 153 mm)

### Mass

Approx. 13.5 oz (approx. 382 g), wall  
bracket excluded

Design and specifications are subject to  
change without notice.

---

# Index

## A

- Adjusting volume
  - handset 18
  - ringer 31, 32
  - speaker 20, 22

## B

- Battery pack
  - charging 9
  - duration 10

## C

- Call waiting service 18, 46
- Caller ID 38
  - Caller ID list 39
  - calling back 42
  - storing in Phone Directory 43
- Caller ID with call waiting 46
- Carrying the handset by the belt clip 50
- Connection 7

## D

- Date and time setting 13
- Dialing mode
  - choosing 12
  - switching to the tone temporarily 18
- Directroy
  - Phone Directory 27, 43

## E, F

- Erasing
  - Caller ID data 40
  - last phone number dialed 21
  - Phone Directory 29

## G, H

- Hold 18, 20, 33, 34

## I, J, K

- Identifying the parts 14
- Intercom 35

## L

- Language of the display 11
- Location, base phone 6

## M, N

- Making calls 18
- Mounting the base phone on a wall 49

## O

- One-touch dialing 23
- OUT OF AREA 39

## P, Q

- Phone Directory 27, 42
- PRIVATE 39
- Pulse dialing 12

## R

- Receiving calls 22
- Redialing 21
- Ringer 31, 32

## S

- Setting up
  - base phone 7
  - handset 9
- Speakerphone 20, 22
- Speed dialing 25
- Storing Caller ID data in Phone Directory 43
- Switching phones during a call 33

## T, U

- Talking between the phones 35
- Three-way conference 37
- Tone dialing
  - dialing mode 12
  - switching to 18
- Troubleshooting 52

## V, W, X, Y, Z

- Volume
  - handset 18
  - ringer 31, 32
  - speaker 20, 22



For the customers in the USA

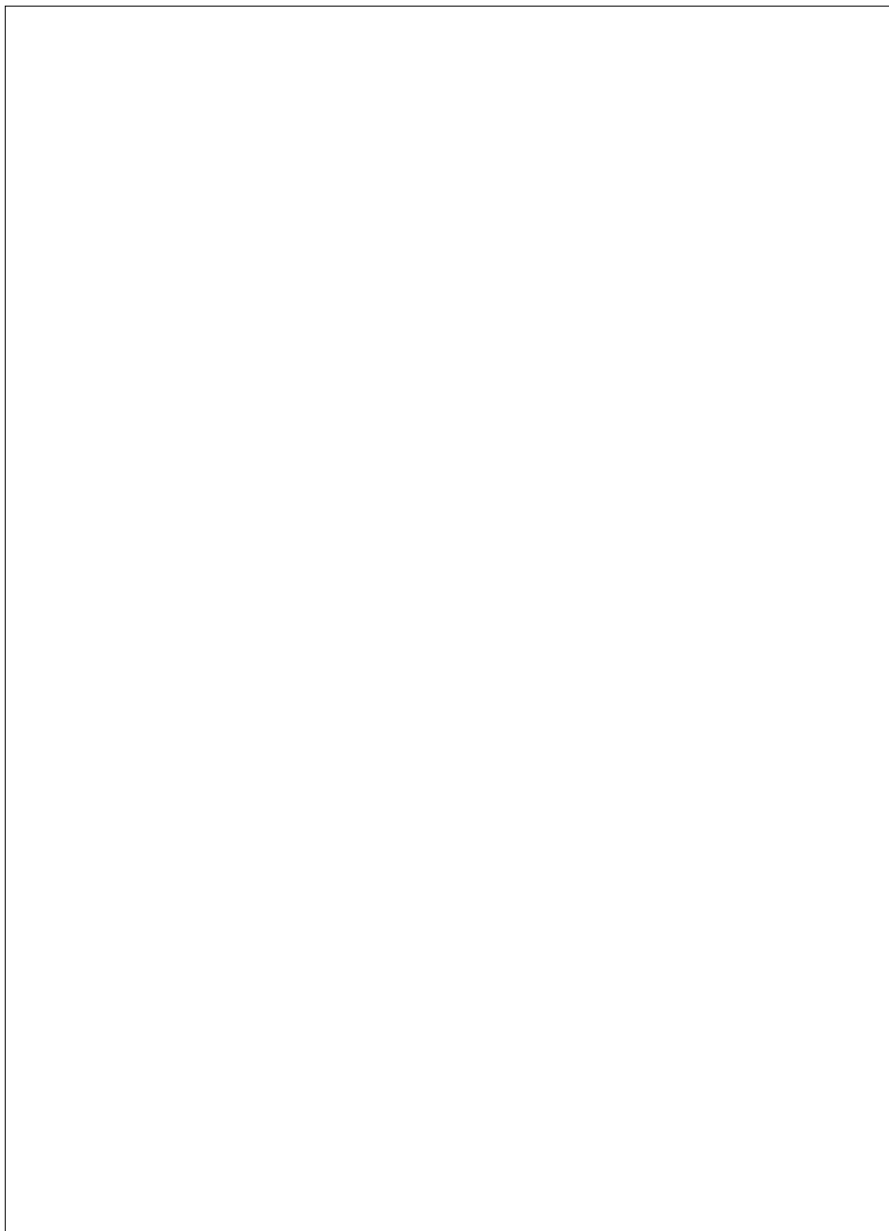

Be sure to save the receipt and attach it to your WARRANTY card when having your equipment repaired at an authorized Sony service center.

For online product registration, please contact  
**[www.sony.com/productregistration](http://www.sony.com/productregistration)**

## Free Manuals Download Website

<http://myh66.com>

<http://usermanuals.us>

<http://www.somanuals.com>

<http://www.4manuals.cc>

<http://www.manual-lib.com>

<http://www.404manual.com>

<http://www.luxmanual.com>

<http://aubethermostatmanual.com>

Golf course search by state

<http://golfingnear.com>

Email search by domain

<http://emailbydomain.com>

Auto manuals search

<http://auto.somanuals.com>

TV manuals search

<http://tv.somanuals.com>