

■ Home Theatre ■ System

Operating Instructions HT-IS100



WARNING

To reduce the risk of fire or electric shock, do not expose this apparatus to rain or moisture.

Batteries or batteries installed apparatus shall not be exposed to excessive heat such as sunshine, fire or the like.

Do not install the appliance in a confined space, such as a bookcase or built-in cabinet.

To prevent fire, do not cover the ventilation of the apparatus with news papers, table-cloths, curtains, etc. And don't place lighted candles on the apparatus.

To prevent fire or shock hazard, do not place objects filled with liquids, such as vases, on the apparatus.

In door use only.



Disposal of Old Electrical & Electronic Equipment (Applicable in the European Union and other European countries with separate collection systems)

This symbol on the product or on its packaging indicates that this product shall not be treated as household waste. Instead it shall be handed over to the applicable collection point for the recycling of electrical and electronic equipment. By ensuring this product is disposed of correctly, you will help prevent potential negative consequences for the environment and human health, which could otherwise be caused by inappropriate waste handling of this product. The recycling of materials will help to conserve natural resources. For more detailed information about recycling of this product, please contact your local Civic Office, your household waste disposal service or the shop where you purchased the product.



Disposal of waste batteries (applicable in the European Union and other European countries with separate collection systems)

This symbol on the battery or on the packaging indicates that the battery provided with this product shall not be treated as household waste. By ensuring these batteries are disposed of correctly, you will help prevent potentially negative consequences for the environment and human health which could otherwise be caused by inappropriate waste handling of the battery. The recycling of the materials will help to conserve natural resources. In case of products that for safety, performance or data integrity reasons require a permanent connection with an incorporated battery, this battery should be replaced by qualified service staff only. To ensure that the battery will be treated properly, hand over the product at end-of-life to the applicable collection point for the recycling of electrical and electronic equipment. For all other batteries, please view the section on how to remove the battery from the product safely. Hand the battery over to the applicable collection point for the recycling of waste batteries. For more detailed information about recycling of this product or battery, please contact your local Civic Office, your household waste disposal service or the shop where you purchased the product.

FOR THE CUSTOMERS IN EUROPE

The manufacturer of this product is Sony Corporation, 1-7-1 Konan Minato-ku Tokyo, 108-0075 Japan. The Authorized Representative for EMC and product safety is Sony Deutschland GmbH, Hedelfinger Strasse 61, 70327 Stuttgart, Germany. For any service or guarantee matters please refer to the addresses given in separate service or guarantee documents.

Copyrights

This system incorporates Dolby* Digital and Pro Logic Surround and the DTS** Digital Surround System.

* Manufactured under license from Dolby Laboratories.

“Dolby”, “Pro Logic”, and the double-D symbol are trademarks of Dolby Laboratories.

** Manufactured under license under U.S. Patent #'s: 5,451,942; 5,956,674; 5,974,380; 5,978,762; 6,487,535 & other U.S. and worldwide patents issued & pending. DTS and DTS Digital Surround are registered trademarks and the DTS logos and Symbol are trademarks of DTS, Inc. © 1996-2007 DTS, Inc. All Rights Reserved.

This system incorporates High-Definition Multimedia Interface (HDMI™) technology.

HDMI, the HDMI logo and High-Definition Multimedia Interface are trademarks or registered trademarks of HDMI Licensing LLC.

“BRAVIA” is a trademark of Sony Corporation.

“S-AIR” and its logo are trademarks of Sony Corporation.

Precautions

On safety

- Should any solid object or liquid fall into the system, unplug the system and have it checked by qualified personnel before operating it any further.
- Do not climb on the subwoofer, as you may fall down and injure yourself, or system damage may result.

On power sources

- Before operating the system, check that the operating voltage is identical to your local power supply. The operating voltage is indicated on the nameplate at the rear of the subwoofer.
- If you are not going to use the system for a long time, be sure to disconnect the system from the wall outlet (mains). To disconnect the AC power cord (mains lead), grasp the plug itself; never pull the cord.
- One blade of the plug is wider than the other for the purpose of safety and will fit into the wall outlet (mains) only one way. If you are unable to insert the plug fully into the outlet, contact your dealer.
- AC power cord (mains lead) must be changed only at the qualified service shop.
- The system is not disconnected from the AC power source (mains) as long as it is connected to the wall outlet, even if the system itself has been turned off.
- Install this system so that the power cord can be unplugged from the wall socket immediately in the event of trouble.

On heat buildup

Although the system heats up during operation, this is not a malfunction. If you continuously use this system at a large volume, the system temperature of the back and bottom rises considerably. To avoid burning yourself, do not touch the system.

On placement

- Place the system in a location with adequate ventilation to prevent heat buildup and prolong the life of the system.
- Do not place the system near heat sources, or in a place subject to direct sunlight, excessive dust, or mechanical shock.
- Do not place anything at the rear of the subwoofer that might block the ventilation holes and cause malfunctions.
- Do not place the system near equipment such as a TV, VCR, or tape deck. (If the system is being used in combination with a TV, VCR, or tape deck, and is placed too close to that equipment, noise may result,

continued

and picture quality may suffer. This is especially likely when using an indoor antenna. Therefore, we recommend using an outdoor antenna.)

- Use caution when placing the system on surfaces that have been specially treated (with wax, oil, polish, etc.) as staining or discoloration of the surface may result.

On operation

Before connecting other components, be sure to turn off and unplug the system.

If you encounter color irregularity on a nearby TV screen

The system is magnetically shielded to allow it to be installed near a TV set. However, color irregularities may still be observed on certain types of TV sets.

If color irregularity is observed...

Turn off the TV set, then turn it on again after 15 to 30 minutes.

If color irregularity is observed again...

Place the system further away from the TV set.

On cleaning

Clean the system with a soft dry cloth. Do not use any type of abrasive pad, scouring powder or solvent such as alcohol or benzine.

If you have any question or problem concerning your system, please consult your nearest Sony dealer.

Table of Contents

Precautions	3
Getting Started	
Supplied Accessories	6
Step 1: Positioning the Speakers.....	7
Step 2: Connecting the Speakers.....	15
Step 3a: Connecting the Components with HDMI Jacks	16
Step 3b: Connecting the Components without HDMI Jacks.....	18
Step 4: Connecting the Antenna (Aerial)	22
Step 5: Connecting the AC Power Cord (Mains Lead).....	24
Step 6: Calibrating the Appropriate Settings Automatically	24
(Auto Calibration)	
Setting up the Sound Output of the Connected Component	28
Function for Conversion of Video Signals	29
Connecting the Other Components.....	30
Playback Options	
Index to Parts and Controls.....	32
Enjoying TV.....	35
Enjoying Other Components.....	36
Surround Functions	
Enjoying the Surround Effects	38
Adjusting the Bass, Middle, and Treble Level	40
Enjoying the Movies at Night.....	40
“BRAVIA” Sync features	
What is “BRAVIA” Sync?.....	41
Preparing for the “BRAVIA” Sync.....	41
Enjoying a Blu-ray Disc/DVD.....	43
(One-Touch Play)	
Enjoying the TV sound from the Speakers	43
(System Audio Control)	
Turning off the TV, System, and Connected Components	45
(System Power Off)	

Tuner Functions

Presetting Radio Stations	46
Listening to the Radio	47
Using the Radio Data System (RDS)	49

Advanced Settings

Controlling the Connected Sony Components with the Remote.....	50
Changing the Input Button Assignments of the Remote	53
Settings and Adjustments Using the Amplifier Menu	54
Reassigning the audio inputs.....	63
Using an S-AIR Product.....	65
Using the IR repeater.....	72

Additional Information

Troubleshooting	73
Specifications	76
Glossary.....	77
Index.....	79

Getting Started

Supplied Accessories

Please check the following accessories in the package.

Remote commander (RM-AAU035) (1)

Size AA (R6) batteries (2)

Optical cable (2.5 m) (1)

FM wire antenna (aerial) (1)

AM loop antenna (aerial) (1)

Calibration mic (1)

Speaker (with Remote commander receiver) (1)

Speakers (4)

Extra speaker pedestal (1)

Brackets (5)

Wrench (1)

Screw (+PSW4 × 12) (1)

Operating Instructions (1)

Quick Start Guide (card) (1)

Inserting batteries into the remote

You can control the system using the supplied remote. Insert two size AA (R6) batteries by matching the + and – ends on the batteries to the markings inside the compartment.

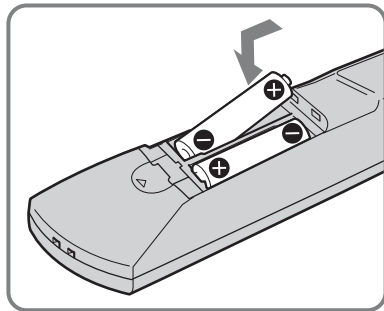
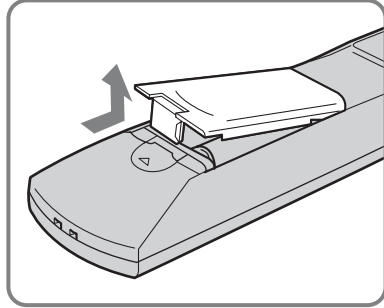

Notes

- Do not leave the remote in an extremely hot or humid place.
- Do not use a new battery with an old one.
- Do not drop any foreign object into the remote casing, particularly when replacing the batteries.
- Do not expose the remote sensor (📷) to direct light from the sun or lighting apparatus. Doing so may cause a malfunction.
- If you do not intend to use the remote for an extended period of time, remove the batteries to avoid possible damage from battery leakage and corrosion.

Step 1: Positioning the Speakers

For the best possible surround sound, all the speakers other than the subwoofer should be placed at the same distance from the listening position (①). Sony recommends that the subwoofer should be placed (②).

Place speakers and subwoofer as illustrated below.

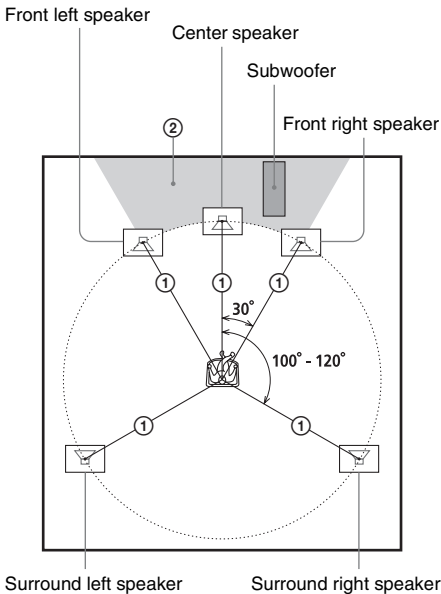

Tips

- You can also place the subwoofer either side, facing the listening position.
- When you install the speaker, the speaker face may be unstable. In this case, use a commercially available wire clammer or a commercially available tape, etc., to secure the speaker cord.

Using the subwoofer efficiently

To reinforce the bass sound, place the subwoofer possible close to a wall.

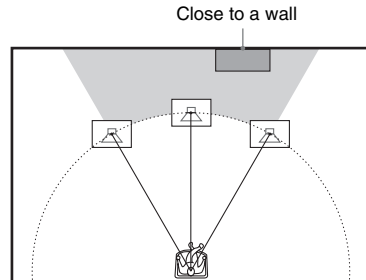

Notes

- If the subwoofer is to be placed ahead of the front speaker, the distance should be less than 0.5 m.*

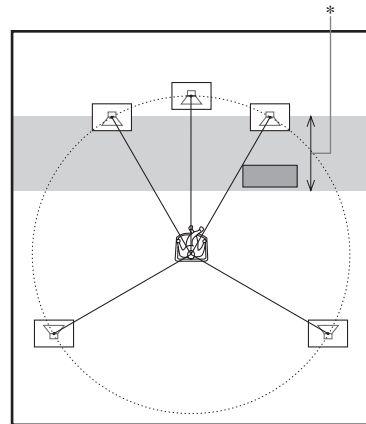

- You may not get the bass sound efficiently when the subwoofer is placed outside (③). You need to adjust the setting of the distance from the listening position.

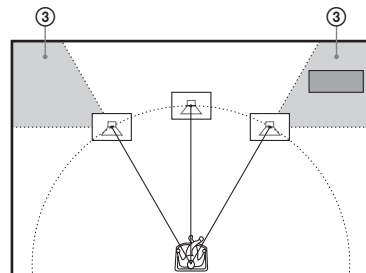

continued

7GB

- Do not place objects on the top of the subwoofer where the speaker unit is installed.

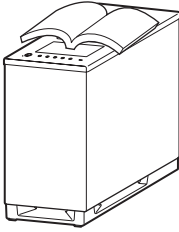

- Do not place the subwoofer under a desk or in a cabinet, etc.

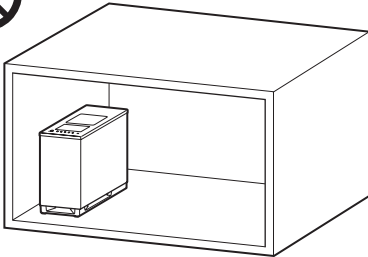
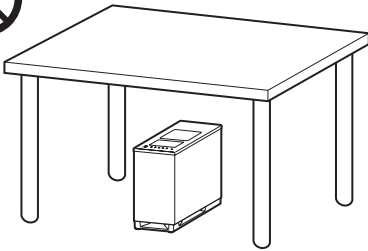

- Do not place the subwoofer back of an obstruction, such as TV, etc. Middle range sound will fall.

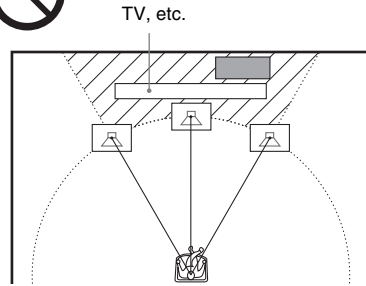

Notes

- Do not set the speakers in an inclined position.
- Do not place the speakers in locations that are:
 - Extremely hot or cold
 - Dusty or dirty
 - Very humid
 - Subject to vibrations
 - Subject to direct sunlight
- Use caution when placing the speakers and/or speaker stands (not supplied) that are attached with the speakers on a specially treated (waxed, oiled, polished, etc.) floor, as staining or discoloration may result.
- When cleaning, use a soft cloth such as a cleaning cloth for glasses.
- Do not use any type of abrasive pad, scouring powder, or solvent such as alcohol or benzene.
- Image distortion on the TV screen may occur depending on the location of the subwoofer. In this case, place the subwoofer away from the TV.

Tip

- When you change the positions of the speakers, Sony recommends that you change the settings. For details, see “Step 6: Calibrating the Appropriate Settings Automatically” (page 24).

Notes on handling the subwoofer

- Place a soft cloth under the subwoofer when you lay the subwoofer down for connection.

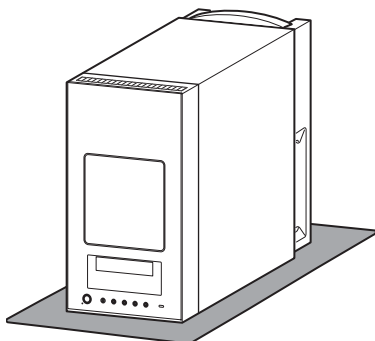

- Do not place your hand into the slit of the subwoofer when lifting it. The speaker driver may be damaged. When lifting, hold the bottom of the subwoofer.

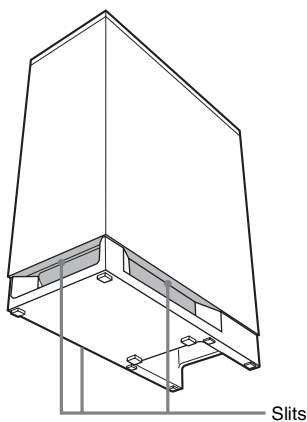

- Do not push the top of the subwoofer where the speaker unit is installed.

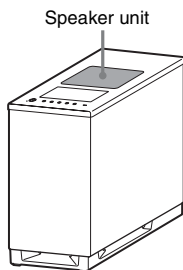

continued

9^{GB}

Installing the speakers on a wall

- 1 Prepare screws (not supplied) that are suitable for the holes of the bracket.
- 2 Secure the bracket to the wall using hole ①.

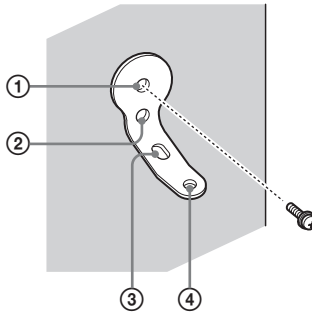

Tip

- To prevent the speaker from rotating, use the hole ②, too.

- 3 Remove the rear cap using the wrench (supplied), and remove the speaker pedestal using a screwdriver (+) (not supplied).

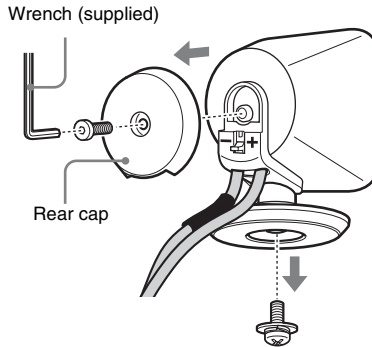

- 4** Push **A** with the supplied wrench (1), and then remove the speaker cords (2).

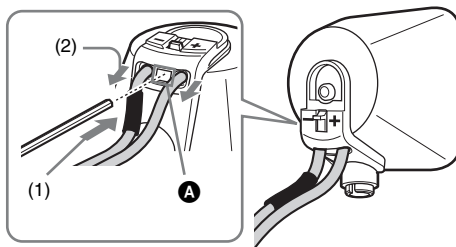

When the lever is down, the speaker cords are locked.

When the lever is up, the speaker cords can be removed.

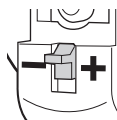
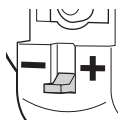

- 5** Thread the speaker cords through hole **3**.

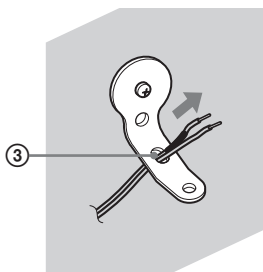

- 6** Reconnect the detached speaker cords, matching \oplus/\ominus to the appropriate speaker terminals (1), and then push the lever down completely (2).

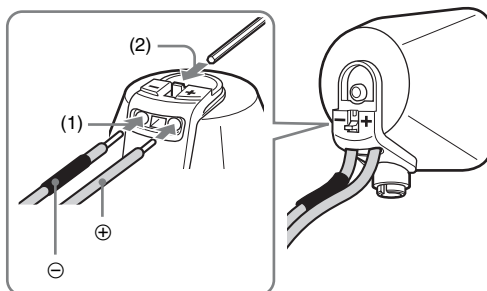

Tip

- If it is difficult to push the lever down, use the wrench (supplied).

continued

7 Reattach the rear cap using the wrench (supplied).

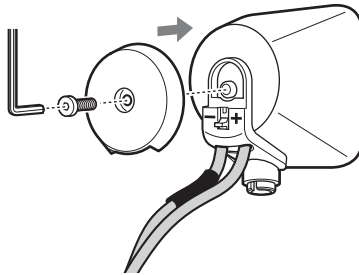

8 Secure the speaker to the bracket with the screw in step 3 using hole ④.

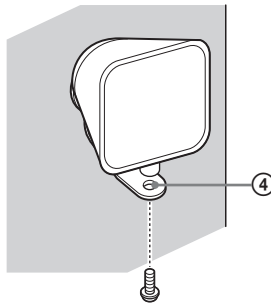

Notes

- Use screws that are suitable for the wall material and strength. As a plaster board wall is especially fragile, attach the screws securely to a beam and fasten them to the wall. Install the speakers on a vertical and flat wall where reinforcement is applied.
- Contact a screw shop or installer regarding the wall material or screws to be used.
- Sony is not responsible for accident or damage caused by improper installation, insufficient wall strength or improper screw installation, natural calamity, etc.

About the center speaker

You can remove the remote commander receiver from the center speaker, allowing them to be used separately.

You can also install the remote commander receiver with the center speaker on a wall.

1 Remove the remote commander receiver using a screwdriver (+) (not supplied).

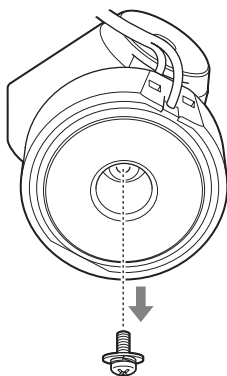

2 Secure the speaker with the screw.

To use the center speaker and remote commander receiver separately.

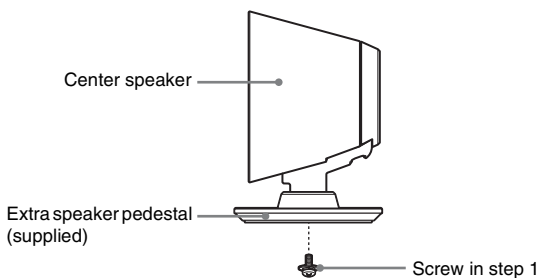

To install the remote commander receiver on a wall.

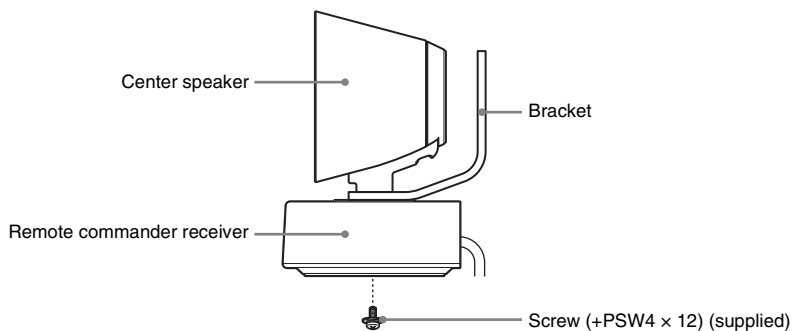

continued

Tip

- You can remove the speaker cords from the connector. With the catch facing down, press and hold the connector down against a flat surface (1) and remove the speaker cords from the connector (2).

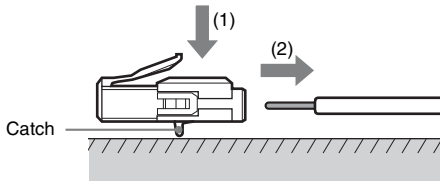
**Note**

- When you reconnect the speaker cords to the connector, be sure to match the speaker cords to the appropriate speaker terminals: \oplus to +, and \ominus to -. Connect the cord with white letters or lines (to which a black tube is also attached on one side) to -. If the cords are reversed, the sound will lack bass and may be distorted.

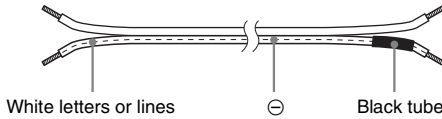
**To avoid short-circuiting the speakers**

Short-circuiting of the speakers may damage the system. To prevent this, be sure to follow these precautions when connecting the speakers. Make sure the bare wire of each speaker cord does not touch another speaker terminal or the bare wire of another speaker cord, such as shown below.

Stripped speaker cord is touching another speaker terminal.



Stripped cords are touching each other due to excessive removal of insulation.

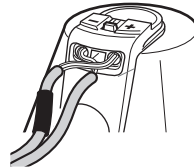

Step 2: Connecting the Speakers

Connect the connectors of the speaker cords to their corresponding SPEAKER jacks. The connectors of the speaker cords are the same color as the jacks to be connected.
Connect the cord of the remote commander receiver to the IR-R100 jack.

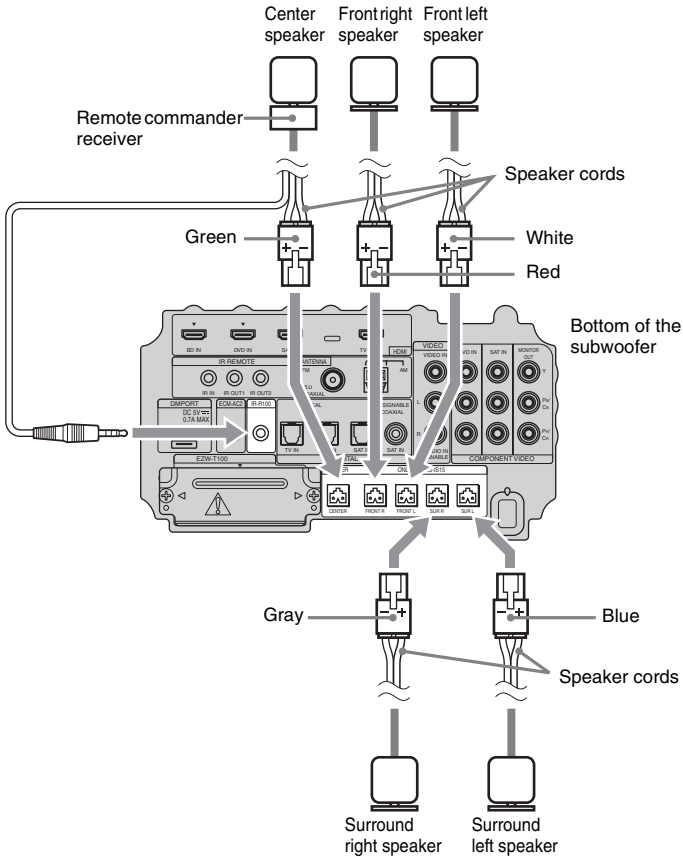

Step 3a: Connecting the Components with HDMI Jacks

Sony recommends that you connect components to the system using an HDMI cable. With HDMI, you can easily enjoy both high quality sound and high quality images.

However, it is necessary to connect the audio output of the TV to the audio input of the system using an optical cable in order to listen to the TV's sound from the system.

For details on the Control for HDMI function, see ““BRAVIA” Sync features” (page 41).

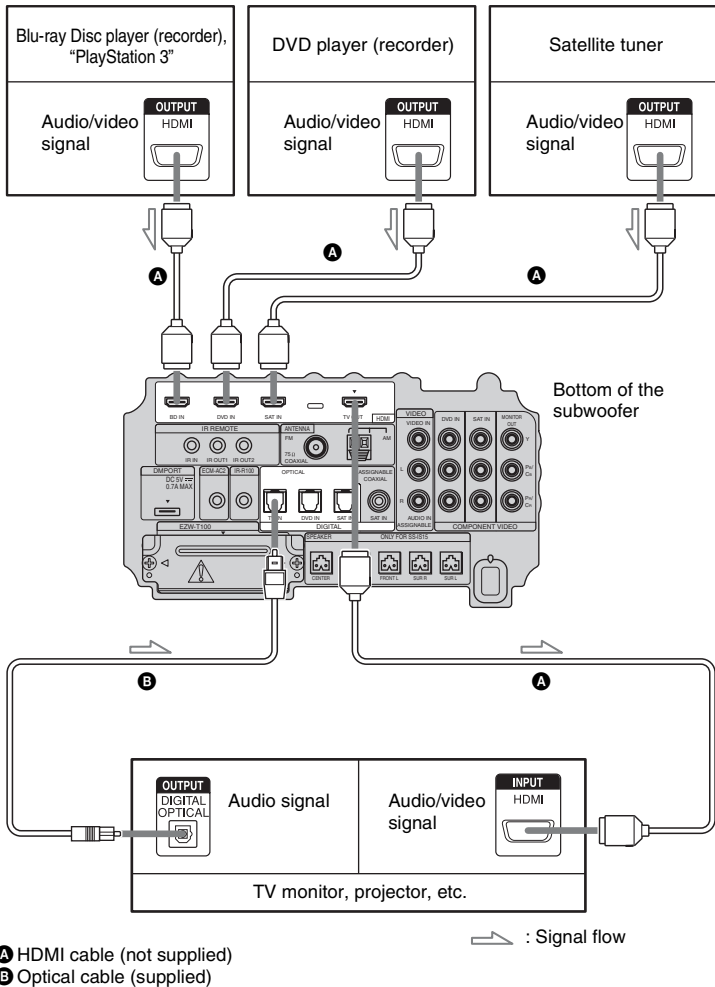

Notes

- For details on connecting to components without HDMI jacks, see page 18.
- The HDMI jack has priority when you connect the component to the system using the HDMI input jacks and other input jacks at the same time.

Notes on HDMI connections

- You can enjoy high quality images using an HDMI cable with an HDMI logo. Sony recommends that you use a Sony HDMI cable.
- Check the setup of the connected component if an image is poor or the sound does not come out of a component connected via the HDMI cable.
- Audio signals (sampling frequency, bit length, etc.) transmitted from an HDMI jack may be suppressed by the connected component.
- Sound may be interrupted when the sampling frequency or the number of channels of audio output signals from the playback component is switched.
- When the connected component is not compatible with copyright protection technology (HDCP), the image and/or the sound from the HDMI TV OUT jack may be distorted or may be not output. In this case, check the specification of the connected component.
- Sony does not recommend using an HDMI-DVI conversion cable.
- Regardless of which input is selected for the system, video signals from the input jack selected the last time are output from the HDMI TV OUT jack.

- To output the TV sound from the speakers connected to the subwoofer, be sure to
 - connect the audio output jacks of the TV to the OPTICAL TV IN jacks of the subwoofer.
 - turn off or mute the TV's volume.

Connecting a DVD player (recorder)

The following illustration shows how to connect a DVD player (recorder).

You can reassign the digital audio input using the ASSIGNABLE COAXIAL SAT IN jack. For details, see “Reassigning the digital audio input” (page 64).

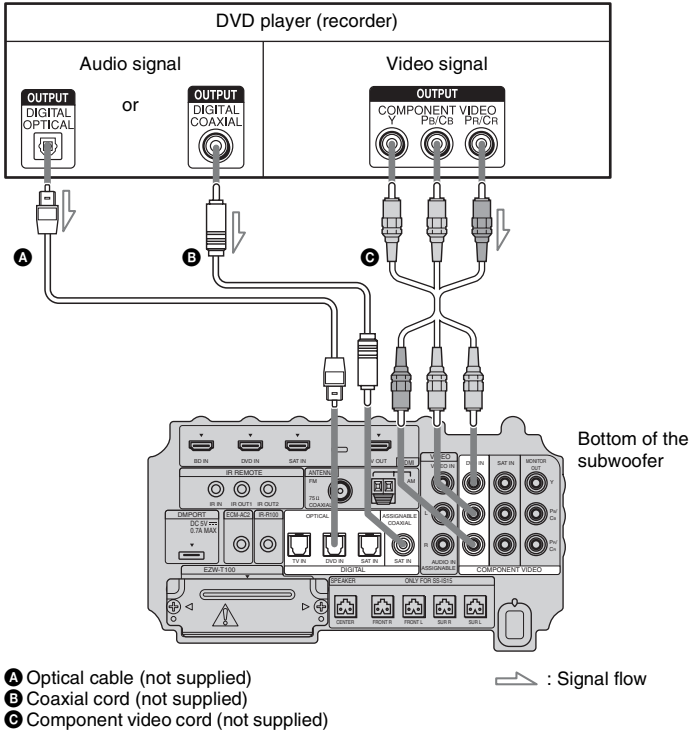

continued

19GB

Connecting a satellite tuner

The following illustration shows how to connect a satellite tuner.

If the satellite tuner does not have an OPTICAL OUT jack, connect the system using the COAXIAL SAT IN jack.

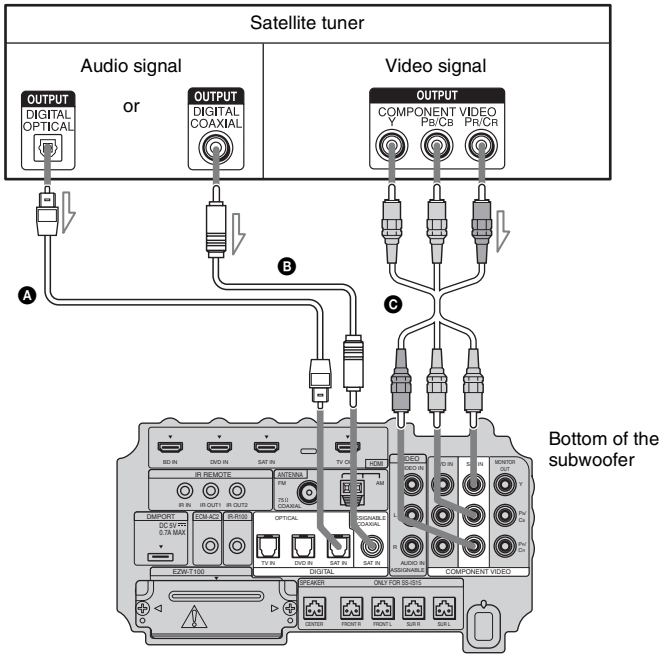

- A** Optical cable (not supplied)
- B** Coaxial cord (not supplied)
- C** Component video cord (not supplied)

↗ : Signal flow

Connecting a VCR

The following illustration shows how to connect a component which has analog jacks such as a VCR, etc.

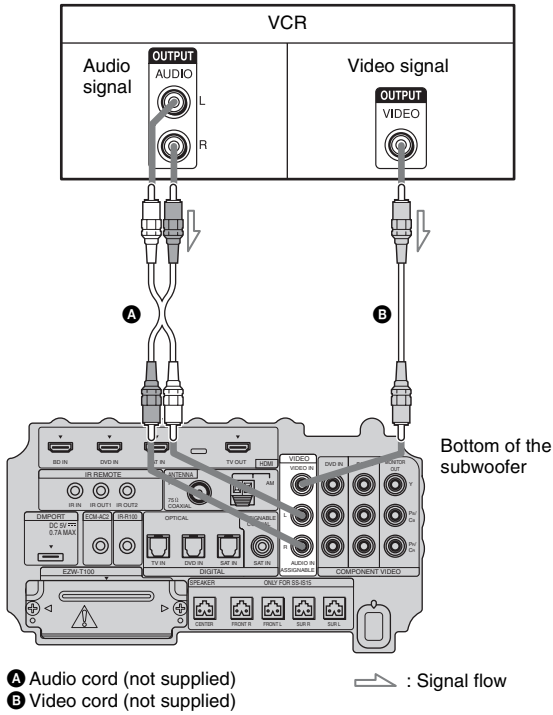

Step 4: Connecting the Antenna (Aerial)

Connecting the AM loop antenna (aerial)

The shape and the length of the antenna (aerial) is designed to receive AM signals. Do not dismantle or roll up the antenna (aerial).

- 1 Remove only the loop part from the plastic stand.
- 2 Set up the AM loop antenna (aerial).

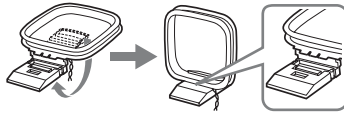

- 3 Connect the cords to the AM antenna (aerial) terminals.

The cords can be connected to either terminal.

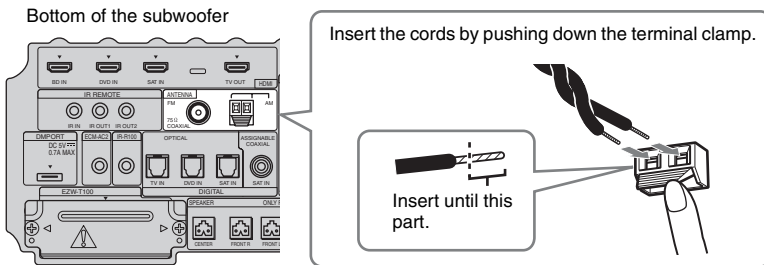

Note

- Do not place the AM loop antenna (aerial) near the system or other AV component, as noise may result.

Tip

- Adjust the direction of the AM loop antenna (aerial) for best AM broadcast sound.

- 4 Make sure the AM loop antenna (aerial) is connected firmly by pulling softly.

Connecting the FM wire antenna (aerial)

Connect the FM wire antenna (aerial) to the FM 75 Ω COAXIAL jack.

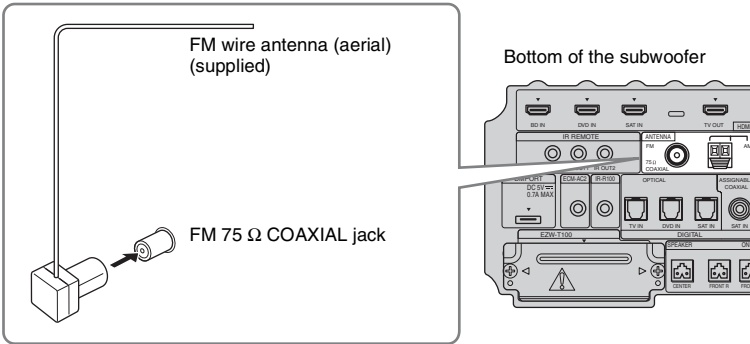

Notes

- Be sure to fully extend the FM wire antenna (aerial).
- After connecting the FM wire antenna (aerial), keep it as horizontal as possible.

Tip

- If you have poor FM reception, use a 75-ohm coaxial cable (not supplied) to connect the subwoofer to an outdoor FM antenna (aerial) as shown below.

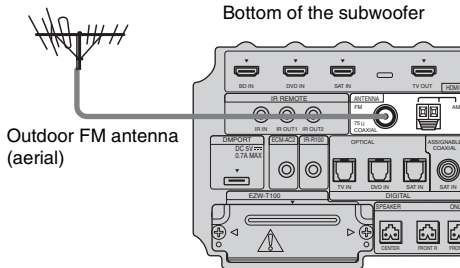

Step 5: Connecting the AC Power Cord (Mains Lead)

Before connecting the AC power cord (mains lead) of the subwoofer to a wall outlet (mains), connect all the speakers to the subwoofer (page 15).

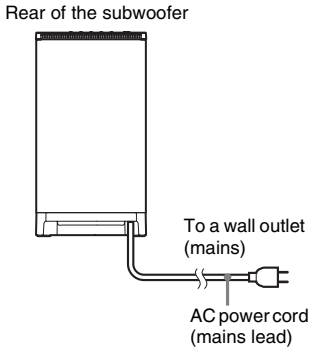

Note

- After connecting the AC power cord (mains lead), wait about 20 seconds before turning on the power by pressing **I/⏻**.

Step 6: Calibrating the Appropriate Settings Automatically

(Auto Calibration)

This subwoofer is equipped with D.C.A.C. (Digital Cinema Auto Calibration) Technology which allows you to perform automatic calibration as follows:

- Check the connection between each speaker and the subwoofer.
- Adjust the speaker level.
- Measure the distance of each speaker to your listening position.
- Measure the frequency characteristics.*

* The measurement result is not utilized for signals with a sampling frequency of more than 96 kHz.

The D.C.A.C. is designed to obtain proper sound balance in your room. However, you can adjust the speaker levels and balance manually according to your preference. For details, see “Setting the speaker level” (page 57).

Before performing the Auto Calibration

Before you perform the Auto Calibration, set up and connect the speakers (page 15).

- The ECM-AC2 jack is used for the calibration mic (supplied) only. Do not connect other microphones to this jack. Doing so may damage the subwoofer and the calibration mic.
- During the calibration, the sound that comes out of the speakers is very loud. Pay attention to the presence of children or to the effect on your neighborhood.
- Perform the Auto Calibration in a quiet environment to avoid the effect of noise and to get a more accurate measurement.
- If there are any obstacles in the path between the calibration mic and the speakers, the calibration cannot be performed correctly. Remove any obstacles from the measurement area to avoid measurement error.

Notes

- If the muting function is on when you perform the Auto Calibration, it will turn off automatically.
- When you use the S-AIR product, disconnect the headphones.

Bottom of the subwoofer

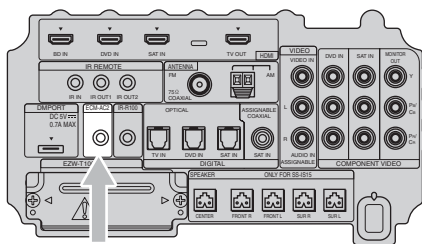

To ECM-AC2 jack

Calibration mic

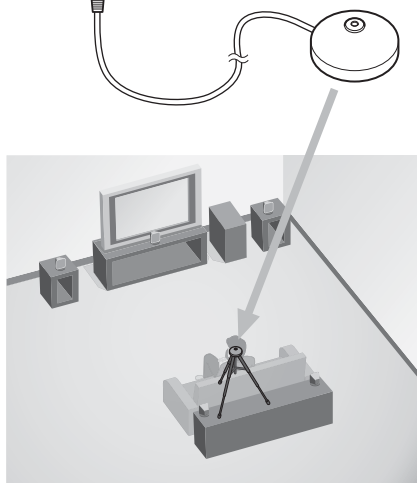

- 1** Connect the calibration mic (supplied) to the ECM-AC2 jack on the subwoofer.
- 2** Set up the calibration mic.

Place the calibration mic at your listening position. You can also use a stool or tripod so that the calibration mic remains at the same height as your ears.

Tip

- The front of each speaker should face the calibration mic. You will get a more accurate measurement.

continued

25^{GB}

Performing the Auto Calibration

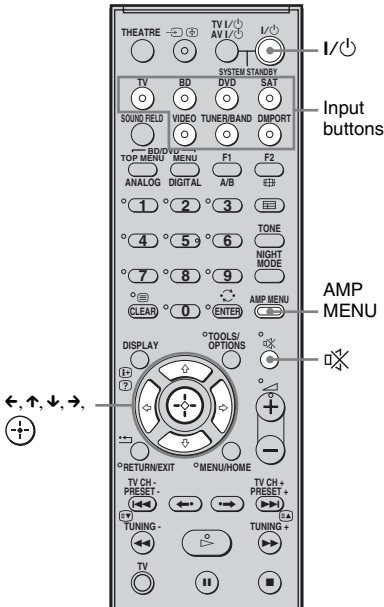

1 Press I/Power.

The system turns on.

2 Press AMP MENU.

Point the remote at the remote sensor (R) on the remote commander receiver.

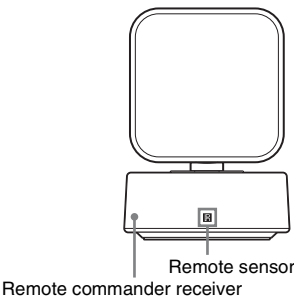

3 Press ↓/↑ repeatedly until “A. CAL MENU” appears on the top panel display, then press (←) or →.

4 Press ↓/↑ to select “A. CAL START,” then press (←).

The Auto Calibration starts after the countdown.

The measurement process will take approximately 30 seconds to complete. The table below shows the display when measurement starts.

Measurement for	Display
Speaker existence	TONE
Speaker gain, distance, frequency response	T.S.P.
Subwoofer gain and distance	SUBWOOFER

Notes

- If “PHONES” appears, you cannot perform the Auto Calibration. Disconnect the headphones from the S-AIR product you are using, then restart the Auto Calibration.
- If “CHECK MIC” appears, you cannot perform the Auto Calibration. Connect the calibration mic, then restart the Auto Calibration.

Tip

- When the Auto Calibration starts:
 - Stand some distance from the speakers and the listening position to avoid measurement failure. This is because test signals are output from the speakers during measurement.
 - Avoid making noise to get a more accurate measurement.

To cancel the Auto Calibration

The Auto Calibration function will be canceled when you do the following during the measurement process:

- Press (MUTE).
- Press input buttons on the remote or INPUT SELECTOR on the subwoofer.
- Change the volume level.

Confirming/saving the measurement result

1 Confirm the measurement result.

When the measurement ends, a beep sounds and the measurement result appears on the top panel display.

Item	Explanation
SAVE EXIT	Saves the measurement result and exits the setting process.
WRN CHECK	Displays warning concerning the measurement result. See “When you select “WRN CHECK”” (page 27).
DIST INFO	Displays the measurement result for speaker distance.
LEVEL INFO	Displays the measurement result for speaker level.
EXIT	Exits the setting process without saving the measurement result.

Note

- After “SAVE EXIT” is displayed for 50 seconds, the measurement result is saved automatically, without the need to saving procedure.

2 Press \downarrow/\uparrow repeatedly to select the desired item, then press $\left(\begin{smallmatrix} \uparrow \\ \downarrow \end{smallmatrix}\right)$ or \rightarrow . To return, press \leftarrow or RETURN.

3 Save the measurement result.

Select “SAVE EXIT” in step 2, then press $\left(\begin{smallmatrix} \uparrow \\ \downarrow \end{smallmatrix}\right)$.

The measurement result is saved.

When error codes appear

Try the remedies and perform the Auto Calibration again.

Item	Explanation
ERROR 32	<ul style="list-style-type: none"> • The sound input from the calibration mic is out of the acceptable range. • The calibration mic or subwoofer may be damaged. Contact your Sony dealer or local authorized Sony service facility.

Item	Explanation
ERROR F 33	<p>The front speakers are not connected.</p> <p>Check that the front speakers are connected properly.</p>
ERROR SR 33	<p>Either the surround left or surround right speaker is not connected.</p> <p>Check that the surround speakers are connected properly.</p>
ERROR SW 33	<p>The subwoofer may be damaged.</p> <p>Contact your Sony dealer or local authorized Sony service facility.</p>

When you select “WRN CHECK”

If a warning on the measurement result is present, detailed information is displayed.

Warning code	Explanation
WARNING 40	The Auto Calibration has completed. However, the noise level is high. You may be able to perform the Auto Calibration properly if you try it again, even though the measurement cannot be performed in all environments. Try to perform the Auto Calibration in a quiet environment.
WARNING 41 WARNING 42	The sound input from the calibration mic is out of the acceptable range. The distance between the calibration mic and the speakers is too closed. Set them away, and then try to perform the Auto Calibration.
WARNING 43	The distance and position of the subwoofer cannot be detected. This may be caused by noise. Try to perform the Auto Calibration in a quiet environment.
NO WARNING	There is no warning information.

continued

When you select “DIST INFO” or “LEVEL INFO”

You can check the speaker distance or speaker level.

Note

- The measurement result of a speaker will not appear if the subwoofer does not recognize that the speaker is connected.

After you have finished



Disconnect the calibration mic from the subwoofer.

Note

- If you have changed the position of the speakers, Sony recommends that you perform the Auto Calibration again in order to enjoy the surround sound.

Deleting the result of the Auto Calibration

You can delete the result of the Auto Calibration. If there is no saved data, you cannot delete the result.

- 1** Press AMP MENU.
- 2** Press ↓/↑ repeatedly until “A.CAL MENU” appears, then press  or →.
- 3** Press ↓/↑ repeatedly to select “A.CAL CLEAR,” then press  or →.
- 4** Press ↓/↑ to select “YES,” then press .

The saved result is deleted.

The settings for speaker distance and speaker level return to their defaults.

Setting up the Sound Output of the Connected Component

Depending on the audio output settings of the connected component, the sound may output in 2 channel sound format only. In this case, set the connected component to output the sound in multi channel sound format (PCM, DTS, Dolby Digital). For details on audio output settings, refer to the operating instructions of the connected component.

Function for Conversion of Video Signals

The subwoofer is equipped with a function for converting video signals.

Video signals and component video signals can be output as HDMI video signals and these up-converted video signals can only be output from the HDMI TV OUT jack. See the illustration that follows.

In the video input/output conversion table of the subwoofer

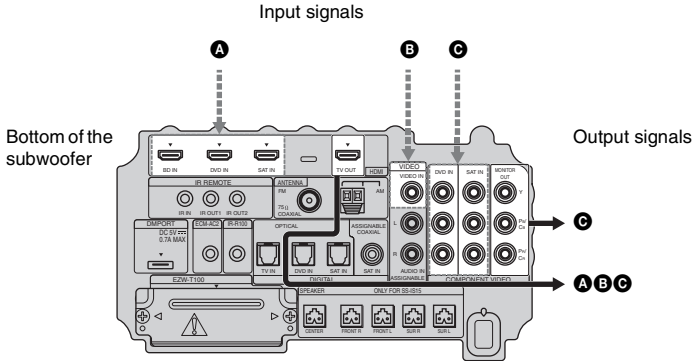

OUTPUT jack \ INPUT jack	HDMI TV OUT	COMPONENT VIDEO MONITOR OUT
HDMI IN A	○	X
VIDEO IN B	◎	X
COMPONENT VIDEO IN C	◎	○

◎: Video signals are up-converted and output through the video converter.

○: The same type of signal as that of the input signal is output. Video signals are not up-converted.

X: Video signals are not output.

Notes on converting video signals

- When video signals from a VCR, etc., are converted on the subwoofer and then output to your TV, depending on the status of the video signal output, the image on the TV screen may appear distorted horizontally, or no image may be output.
- HDMI video signals cannot be converted to component video signals.
- The up-converted video signals are output only from the HDMI OUT jack. They are not output from any other video jacks.
- When you play back a VCR with an image improvement circuit, such as TBC, the images may be distorted or may not be output. In this case, set the image improvement circuit function to off.

Connecting the Other Components

To connect the DIGITAL MEDIA PORT adapter

You can enjoy sound from a component connected to the subwoofer, using the DIGITAL MEDIA PORT adapter.

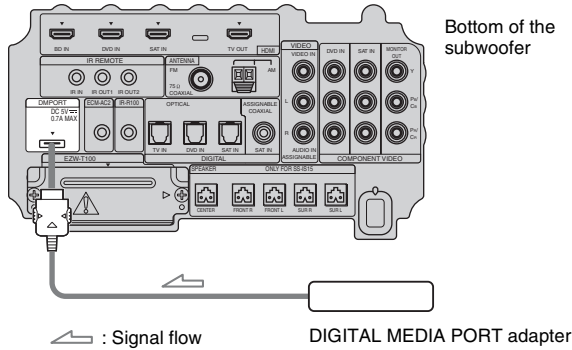

Notes

- Do not connect or disconnect the DIGITAL MEDIA PORT adapter while the system is turned on.
- When you connect the DIGITAL MEDIA PORT adapter, be sure the connector is inserted with the arrow mark facing toward the arrow mark on the DMPORT jack. To detach the DIGITAL MEDIA PORT adapter, press and hold **A** and then pull out the connector.

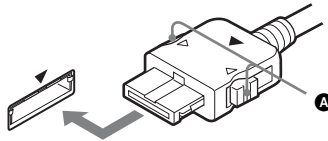

To use the wireless system

The system is compatible with the S-AIR function, which allows sound transmission between the subwoofer and S-AIR product (not supplied). When you purchase the S-AIR product, you need to establish sound transmission.

For details, see page 65.

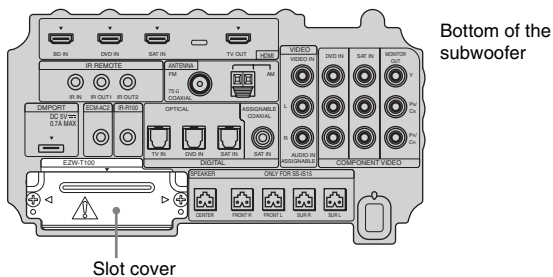

Bottom of the subwoofer

CAUTION

- There is no need to open the slot cover until the S-AIR product is used.

Index to Parts and Controls

For more information, see the pages indicated in parentheses.

Top panel

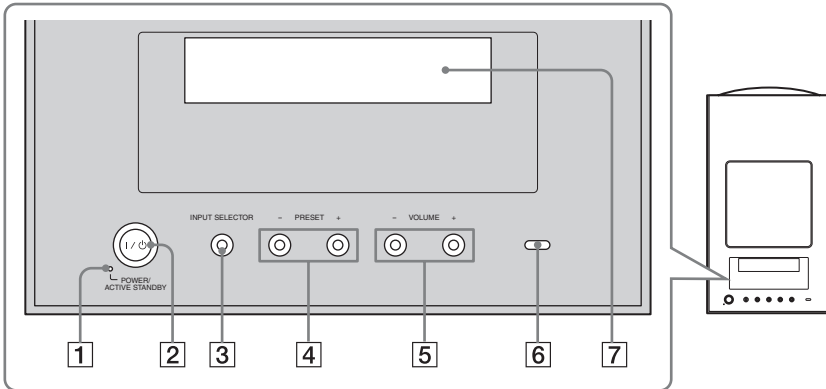

1 POWER / ACTIVE STANDBY

Green: the system turns on.

Amber: the Control for HDMI function or the S-AIR STANDBY MODE function is working while the system is turned off.

No light: the system is turned off, and the Control for HDMI function and the S-AIR STANDBY MODE function is not working.

2 I/⏻ (on/standby)

Press to turn the system on or off.

3 INPUT SELECTOR

Press to select the input source to play back.

4 PRESET -/+

Press to go to the previous/next preset radio station.

5 VOLUME -/+

Press to adjust the volume level.

6 S-AIR

Green: the S-AIR transmitter (not supplied) is inserted in the subwoofer and the system establishes sound transmission.

No light: the system does not establish sound transmission by the S-AIR function.

7 Top panel display

Check the system status.

About the indications in the top panel display

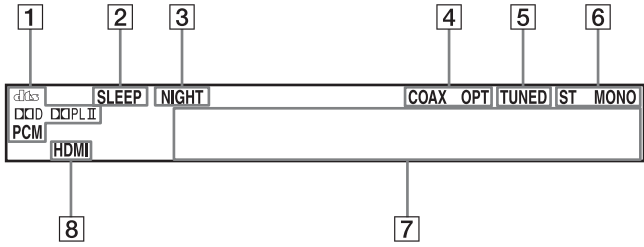

- 1 Lights up according to the audio input signals.**
- 2 SLEEP (62)**
Flashes when the Sleep Timer function is active.
- 3 NIGHT (40)**
Lights up when the night mode is on.
- 4 COAX/OPT**
Lights up according to the coaxial or optical signal being input.
- 5 TUNED (46)**
Lights up when a radio station is received.
- 6 ST/MONO (47)**
Lights up according to the stereo or monaural status of the radio.
- 7 Displays system's status.**
Radio frequency, sound field, etc.
- 8 HDMI (16, 74)**
Lights up when an HDMI component is being used.

continued

Remote control

Here describes the buttons for amplifier operation only. See page 50 for the buttons for operation of the connected components.

Note

- Point the remote at the remote sensor (📡) on the remote commander receiver.

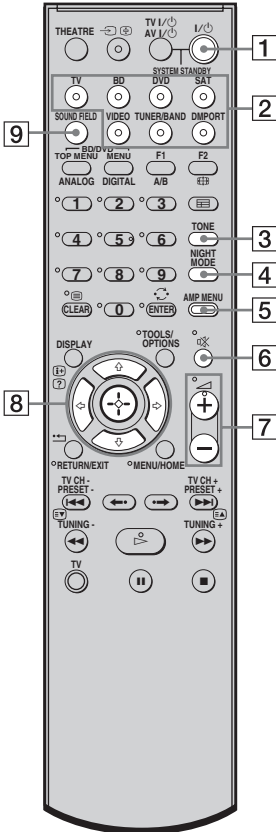

* The 5, \triangleright , and \triangleleft + buttons have a tactile dot. Use it as a guide during operation.

1 I/O (on/standby)

Press to turn the system on or off.

To save the power in standby mode

Press I/O while the system turns on.

To enter power saving mode, make sure that the system is in the following status.

- “CTRL: HDMI” is set to “CTRL OFF” (page 41).
- “S-AIR STBY” is set to “STBY OFF” (page 71).

To cancel standby mode, press I/O once.

2 Input buttons

Press one of the buttons to select the component you want to use.

The buttons are factory assigned to control Sony components. You can change the factory settings of the input buttons to suit the components in your system. For details, see “Changing the Input Button Assignments of the Remote” (page 53).

3 TONE

Press to adjust the bass, middle, and treble level (page 40).

4 NIGHT MODE

Press to enjoy sound effects for watching movies at night (page 40).

5 AMP MENU

Press to display the menu of the system (page 54).

6 Muting

Press to turn off the sound.

7 +/-

Press to adjust the volume.

8 \leftarrow , \uparrow , \downarrow , \rightarrow or \oplus

Press \leftarrow , \uparrow , \downarrow or \rightarrow to select the settings. Then press \oplus to enter the selection.

9 SOUND FIELD

Press to select the sound field (page 38).

Enjoying TV

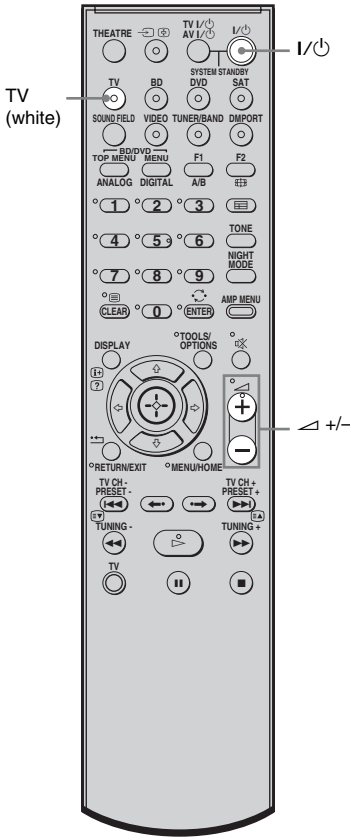

- 1 Turn on the TV and choose a program.**
For details, refer to the operating instructions of the TV.
- 2 Turn the system on.**
- 3 Press TV (white) on the remote.**
- 4 Adjust the volume of the system.**

Tips

- When you connect a Sony TV, the audio input of the TV is switched and the image from the TV tuner is displayed on the TV screen automatically by pressing the TV (white) button. To change this setting, see “Changing the Input Button Assignments of the Remote” (page 53).
- The sound may be output from the TV’s speaker. In this case, turn the volume of the TV’s speaker down to the minimum.

Enjoying Other Components

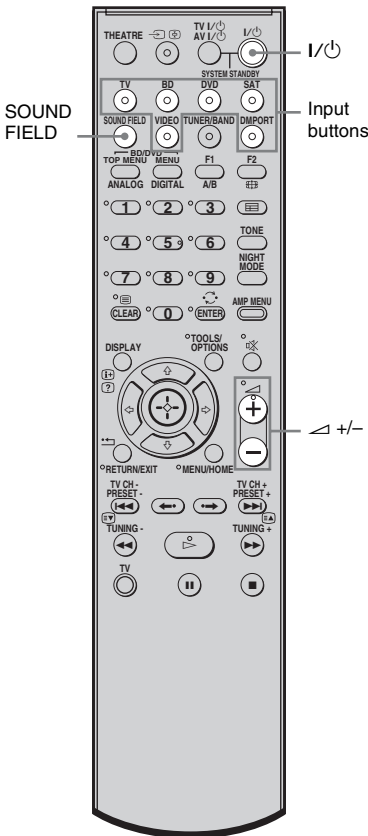

Enjoying a satellite tuner

- 1 Turn on the TV.
For details, refer to the operating instructions of the TV.
- 2 Turn the satellite tuner and the system on.
- 3 Press SAT on the remote.
- 4 Change the TV input.
For details, refer to the operating instructions of the TV.
- 5 Adjust the volume of the system.

Tip

- The sound may be output from the TV's speaker. In this case, turn the volume of the TV's speaker down to the minimum.

Enjoying Blu-ray Disc, DVD, or "PlayStation 3"

- 1 Turn on the TV.
- 2 Turn the Blu-ray Disc/DVD player (recorder) or "PlayStation 3" and the system on.
- 3 Press DVD or BD on the remote.
- 4 Change the TV input.
For details, refer to the operating instructions of the TV.
- 5 Play back the disc.

Tip

- Even if you playback Dolby True HD, Dolby Digital Plus or DTS-HD with a connected component compatible with these sound formats, the system accepts as Dolby Digital or DTS. When you connect the component to the system using an HDMI cable to playback these high-quality sound formats, set the connected component to output the sound in multi channel PCM, if possible.

Enjoying a VCR

- 1** Turn on the TV.
- 2** Turn the VCR player and the system on.
- 3** Press VIDEO on the remote.
- 4** Change the TV input.
For details, refer to the operating instructions of the TV.
- 5** Play back the tape on the VCR.

Enjoying a connected component through DMPORT connection

- 1** Press DMPORT on the remote.
- 2** Start playback of the connected component.

Tip

- When listening to MP3 or other compressed music files using a portable audio source, you can enhance the sound. Press SOUND FIELD repeatedly until "P. AUDIO" appears in the top panel display.

Surround Functions

Enjoying the Surround Effects

Selecting the sound field

This system can create multi channel surround sound. You can select one of the optimized sound fields from the system's preprogrammed sound fields.

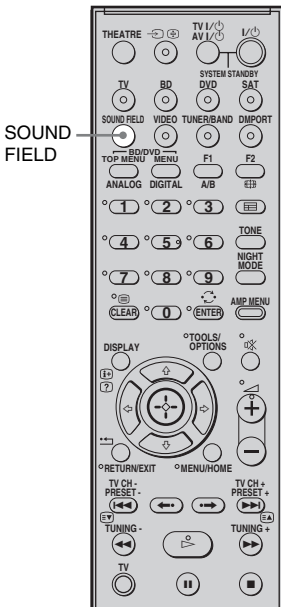

Enjoying Surround Sound Using Sound Field

Press **SOUND FIELD**.

The present sound field appears.

Each time you press the **SOUND FIELD** button, the display changes cyclically as follows:

A.F.D. STD → A.F.D. MULTI →
PLII MOVIE → PLII MUSIC → SPORTS →
NEWS → P. AUDIO → OMNI-DIR →
A.F.D. STD → ...

Press **SOUND FIELD** repeatedly until the sound field you want appears.



Available sound fields

Sound field	Display
AUTO FORMAT DIRECT STANDARD	A.F.D. STD
AUTO FORMAT DIRECT MULTI	A.F.D. MULTI
Dolby Pro Logic II MOVIE	PLII MOVIE
Dolby Pro Logic II MUSIC	PLII MUSIC
SPORTS	SPORTS
NEWS	NEWS
PORTABLE AUDIO ENHANCER	P. AUDIO
OMNI-DIRECTIONAL SOUND	OMNI-DIR

Automatic outputting of the original sound

■ AUTO FORMAT DIRECT STANDARD

The auto decoding function automatically detects the type of audio signal being input (Dolby Digital, DTS, or standard 2 channel stereo) and performs the proper decoding if necessary. This mode presents the sound as it was recorded/encoded, without adding any effects (e.g. reverberation).

However, if there are no low frequency signals (Dolby Digital LFE, etc.), it will generate a low frequency signal for output to the subwoofer.

Outputting the sound from multiple speakers

■ AUTO FORMAT DIRECT MULTI

This mode lets you enjoy audio playback of all types of discs from multiple speakers.

Notes

- The sound is not output from multiple speakers depending on the source.
- Depending on the disc or source, the beginning of the sound may be cut off as the optimum mode is automatically selected. To avoid cutting the sound, select "A.F.D. STD."

Outputting 2 channel sources like CDs by 5.1 channel

■ Dolby Pro Logic II MOVIE/MUSIC

Dolby Pro Logic II produces five full-bandwidth output channels from 2 channel sources. This is done using an advanced, high-purity matrix surround decoder that extracts the spatial properties of the original recording without adding any new sounds or tonal colorations.

Notes

- When the input signal is multi channel source, Dolby Pro Logic II MOVIE/MUSIC are canceled and the multi channel source is output directly.
- When the bilingual broadcast sound is input, Dolby Pro Logic II MOVIE/MUSIC are not effective.

Enjoying the sound effects

■ SPORTS

This mode produces clear play-by-play commentary and realistic sound with surround effects, such as cheering, etc.

■ NEWS

This mode produces the clear announcer's voice.

■ PORTABLE AUDIO ENHANCER

This mode reproduces a clear enhanced sound image from your portable audio device. This mode is ideal for MP3 and other compressed music.

Note

- Multi channel Linear PCM is not available for "P. AUDIO."

■ OMNI-DIRECTIONAL SOUND

This mode reproduces the stereo effect everywhere surrounding by five satellite speakers.

To turn the surround effect off

Press SOUND FIELD repeatedly until "A.F.D. STD" appears in the top panel display.

Tip

- The sound fields memorized for each input are retained even if you disconnect the AC power cord (mains lead).
Whenever you select a function such as "DVD" or "TUNER," the sound field that was last applied to function is automatically applied again. For example, if you listen to DVD with Dolby Pro Logic II MOVIE as the sound field, then change to another function, and then return to DVD, Dolby Pro Logic II MOVIE will be applied again.

Adjusting the Bass, Middle, and Treble Level

You can adjust the bass, middle, and treble level easily.

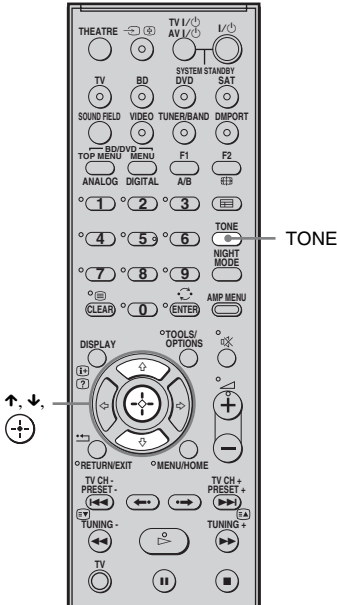

1 Press **TONE** repeatedly until “BASS,” “MIDDLE,” or “TREBLE” appears in the top panel display.

- **BASS:** adjusts the bass level (-6.0 – +6.0 dB, 0.5 dB steps).
- **MIDDLE:** adjusts the middle level (-6.0 – +6.0 dB, 0.5 dB steps).
- **TREBLE:** adjusts the treble level (-6.0 – +6.0 dB, 0.5 dB steps).

2 Press **↑/↓** to adjust.

The adjusted value appears in the top panel display.

3 Press **⊕**.

Note

- When you use the S-AIR functions with the headphones, “MIDDLE” appears. However, middle level is not available for the headphones.

Enjoying the Movies at Night

You can enjoy sound effects or dialog, as you would in a movie theatre, even at low volume. It is useful for watching movies at night.

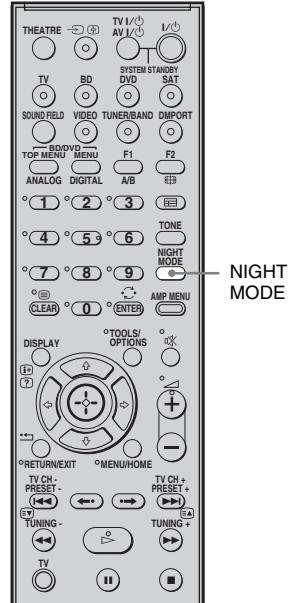

Press **NIGHT MODE**.

“NIGHT” lights up in the top panel display and the sound effect is activated.

To turn off the sound effect

Press **NIGHT MODE** again.

“BRAVIA” Sync features

What is “BRAVIA” Sync?

By connecting Sony components that are compatible with the “BRAVIA” Sync with an HDMI cable (not supplied), operation is simplified as below:

- **One-Touch Play:** When you play back a component such as a Blu-ray Disc/DVD player (recorder), the system and the TV are turned on automatically and switch to the appropriate HDMI input.
- **System Audio Control:** While watching TV, you can select to output the sound from the TV speaker or the speakers of the system.
- **System Power Off:** When you turn off the TV, the system and the connected components are also turned off simultaneously.

“BRAVIA” Sync is compatible with a Sony TV, Blu-ray Disc/DVD player, AV amplifier, etc., with the Control for HDMI function.

Control for HDMI is a mutual control function standard used by CEC (Consumer Electronics Control) for HDMI (High-Definition Multimedia Interface).

The Control for HDMI function will not operate in the following cases:

- When you connect this system to a component which does not correspond with the Control for HDMI function.
- When you connect the system and components using other than HDMI connection.

Sony recommends that you connect this system to products featuring “BRAVIA” Sync.

Note

- Depending on the connected component, the Control for HDMI function may not work. For details, refer to the operating instructions of the component.

Preparing for the “BRAVIA” Sync

To use the “BRAVIA” Sync, set the Control for HDMI function to on for the system and the connected component.

When you connect a Sony TV with the Control for HDMI function, the Control for HDMI function for the system and the connected component can be set simultaneously by setting the Control for HDMI function of the TV.

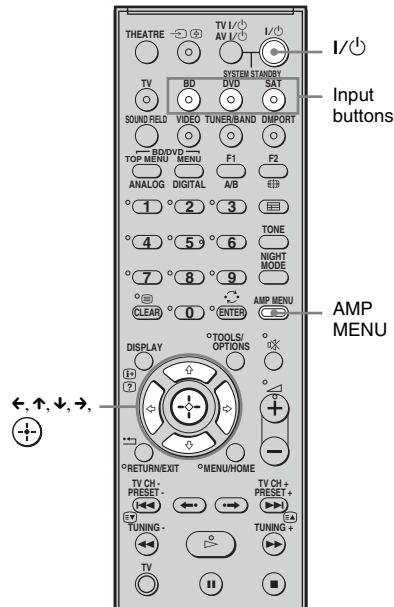

- 1** Make sure that the system is connected to the TV and the connected components (which should be compatible with the Control for HDMI function) using HDMI cables (not supplied).
- 2** Turn on the system, the TV, and the connected components.

continued

3 Select the input of the system connected to the component you want to watch (BD, DVD, SAT), and switch the HDMI input of the TV, so that an image from the connected component is displayed.

4 Set the Control for HDMI function of the TV to on.

The Control for HDMI function for the system and the connected component is simultaneously set to on.

During the setting, "SCANNING" appears in the top panel display. After you finish the setting, "COMPLETE" appears in the top panel display. Wait until the setting is complete.

If "SCANNING" or "COMPLETE" does not appear after performing the steps above

Set the Control for HDMI function to on for the system and the connected component individually.

1 Press AMP MENU.

2 Press ↓/↑ repeatedly until "SET HDMI" appears, then press  or →.

3 Press ↓/↑ repeatedly until "CTRL: HDMI" appears, then press  or →.

4 Press ↓/↑ to select "CTRL ON," then press  or →.

5 Press AMP MENU.

The AMP menu turns off. The Control for HDMI function is set to on.

6 Set the Control for HDMI function of the connected component to on.

For details, refer to the operating instructions of the connected component.

7 Select the input of the system connected to the component you want to use the Control for HDMI function for (BD, DVD, SAT), and repeat step 6.

If you add or reconnect the component

Perform steps of "Preparing for the "BRAVIA" Sync" and "If "SCANNING" or "COMPLETE" does not appear after performing the steps above" again.

Notes

- During the setting of the Control for HDMI function for the system, the System Audio Control function does not work.
- If the Control for HDMI function for the connected component cannot be set simultaneously by setting "Control for HDMI" of the TV, set the Control for HDMI function using the menu of the connected component.
- For details on setting the TV and the connected components, refer to their operating instructions.

Tip

- The default setting of the Control for HDMI function of the system is "OFF."

Enjoying a Blu-ray Disc/ DVD

(One-Touch Play)

Play back a connected component.

The system and the TV are turned on automatically and switch to the appropriate HDMI input.

Note

- Depending on the TV, the start of the content may not be output.

Tip

- You can enjoy the Blu-ray Disc/DVD player (recorder) connected to the system, even if you turn the system off. The POWER / ACTIVE STANDBY indicator lights up in amber at this time.

Enjoying the TV sound from the Speakers

(System Audio Control)

You can enjoy the TV sound from the speakers of the system by means of a simple operation. For details, refer to the operating instructions of the TV.

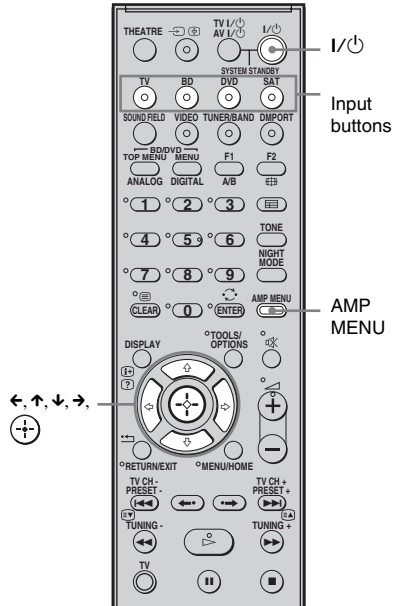

Press I/⏻ to turn on the system.

The sound is output from the speakers of the system. The sound is output from the TV's speaker when you turn the system off.

Note

- When the TV is turned on before this system is turned on, the TV sound will not be output for a moment.

Tip

- You can adjust the volume and turn off the sound of the system using the TV remote.

continued

Using the Volume Limit function

When the System Audio Control function is active, and the output method changes from the TV speaker to the system speaker automatically, loud sound may be output depending on the volume level of the system. You can prevent this by limiting the maximum volume level.

- 1 Press AMP MENU.**
- 2 Press \downarrow/\uparrow repeatedly until "SET HDMI" appears, then press \oplus or \rightarrow .**
- 3 Press \downarrow/\uparrow repeatedly until "VOL LIMIT" appears, then press \oplus or \rightarrow .**
- 4 Press \downarrow/\uparrow to select the maximum volume level you want.**

The maximum volume level changes as follows:

MAX \leftrightarrow 49 \leftrightarrow 48 \leftrightarrow
..... \leftrightarrow 2 \leftrightarrow 1 \leftrightarrow MIN

5 Press AMP MENU.

The AMP menu turns off.

Notes

- This function is available only when the Control for HDMI function is set to on.
- This function is not available when the output method changes from the system speaker to the TV speaker.

Tips

- Sony recommends that you set the maximum volume level to a little lower than the volume you usually listen to.
- Regardless of the maximum volume level you set, the VOLUME +/- button of the subwoofer and the \triangleleft +/- button of the remote are operable.
- If you do not want to limit the maximum volume level, select "MAX."

Using the input buttons of the remote

The input buttons (TV (white), BD, DVD, SAT, VIDEO, DMPORT) work as follows when the Control for HDMI function is set to on.

- BD, DVD, SAT, VIDEO, DMPORT: Since the input of the TV is also switched automatically, you can watch the image of the selected component on the TV simply by pressing the buttons.
- TV: The input of the TV switches automatically. When you connect a Sony TV, you can watch the TV simply by pressing the button.

Tip

- You can control connected Sony components by pressing the input buttons. For details, see "Controlling the Connected Sony Components with the Remote" (page 50).

Turning off the TV, System, and Connected Components

(System Power Off)

When you turn the TV off by using the power button on the TV's remote, the system and the connected components turn off automatically. Also, when you turn the TV off by using the system's remote, the system and the connected components turn off automatically.

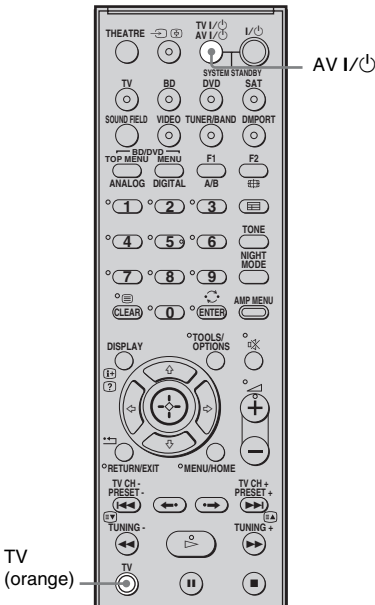

Hold down TV (orange), and press AV I / ⏻.

The TV, the system, and the connected components are turned off.

Note

- Depending on the status, the connected components may not be turned off. For details, refer to the operating instructions of the connected components.

Tuner Functions

Presetting Radio Stations

You can preset 20 FM stations, and 10 AM stations. Before tuning, make sure to turn the volume down to minimum.

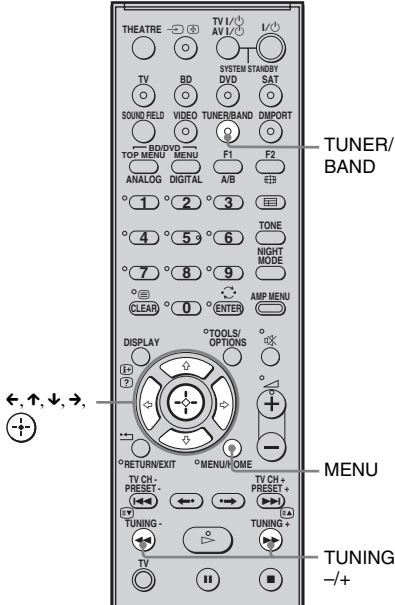

- 1 Press TUNER/BAND.**
You can change “FM” or “AM” by pressing TUNER/BAND.
- 2 Press and hold TUNING + or – until the auto scanning starts.**
Scanning stops when the system tunes in a station. “TUNED” and “ST” (for stereo program) light up in the top panel display.
- 3 Press MENU.**
- 4 Press \uparrow/\downarrow repeatedly until “Memory?” appears in the top panel display.**

- 5 Press \oplus .**

A preset number appears in the top panel display.



- 6 Press \uparrow/\downarrow to select the preset number you want.**



Tip

- You can select the preset number directly by pressing the number buttons.

- 7 Press \oplus .**

The station is stored.



- 8 Press MENU.**

- 9 Repeat 2 to 8 to store other stations.**

To change the preset number

Restart from step 3.

Changing the AM tuning interval (for Australian models)

The AM tuning interval can be set to either 10 kHz or 9 kHz.

- 1 Press TUNER/BAND repeatedly until “AM” appears in the top panel display.**
- 2 Press MENU.**
- 3 Press \uparrow/\downarrow repeatedly until “AM Step?” appears in the top panel display, then press \oplus or \rightarrow .**
“9k \rightarrow 10k” or “10k \rightarrow 9k” appears in the top panel display.
- 4 Press \oplus .**
“Complete!” appears in the top panel display. The AM tuning interval is changed.
- 5 Press MENU.**

Note

- If you change the interval, AM preset stations will be erased.

Listening to the Radio

Preset radio stations in the system's memory first (see "Presetting Radio Stations" (page 46)).

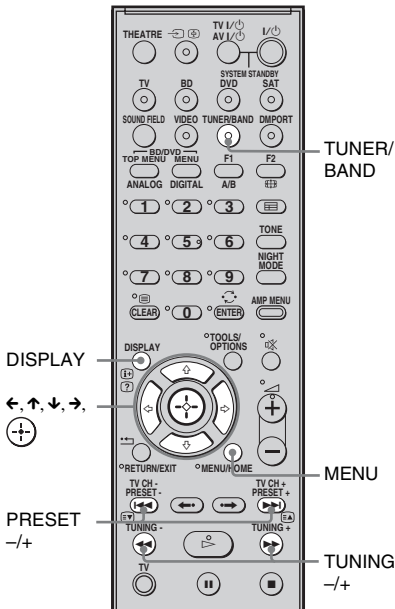

- 1 Press TUNER/BAND.**
The last received station is tuned in.
You can change "FM" or "AM" by pressing TUNER/BAND.
- 2 Press PRESET + or - repeatedly to select the preset station.**
Each time you press the button, the system tunes in one preset station.
You can select the preset number directly by pressing the number buttons.
- 3 Adjust the volume of the system.**

To turn off the radio

Press I/O to turn off the system, or change to another function.

To listen to non-preset radio stations

Use manual or automatic tuning in step 2.

For manual tuning, press TUNING + or - repeatedly.

For automatic tuning, press and hold TUNING + or -. The automatic tuning stops automatically when the system receives a radio station. To stop the automatic tuning manually, press TUNING + or -.

If an FM program is noisy

If an FM program is noisy, you can select monaural reception. There will be no stereo effect, but reception will improve.

- 1 Press MENU.**
- 2 Press ↑/↓ repeatedly until "FM Mode?" appears in the top panel display, then press ⊕ or ⊖.**
- 3 Press ↑/↓ to select "MONO."**
The default setting is underlined.
 - STEREO: stereo reception.
 - MONO: monaural reception.
- 4 Press ⊕.**
- 5 Press MENU.**

Tip

- To improve reception, reorient the supplied antennas (aerials).

Naming preset stations

You can enter a name for preset stations. These names (for example, “XYZ”) appear in the top panel display when a station is selected. Note that no more than one name can be entered for each preset station.

1 Press TUNER/BAND.

The last received station is tuned in.

You can change “FM” or “AM” by pressing TUNER/BAND.

2 Press PRESET + or – repeatedly to select the preset station you want to create an index name for.

3 Press MENU.

4 Press \uparrow/\downarrow repeatedly until “Name In?” appears in the top panel display.



5 Press \oplus .

6 Create a name by using $\leftarrow/\uparrow/\downarrow/\rightarrow$.

Press \uparrow/\downarrow to select a character, then press \rightarrow to move the cursor to the next position.

Letters, numbers, and other symbols can be input for a radio station name.

If you enter a wrong character

Press \leftarrow/\rightarrow repeatedly until the character to be changed flashes, then press \uparrow/\downarrow to select the desired character.

To erase the character, press \leftarrow/\rightarrow repeatedly until the character to be erased flashes, then press CLEAR.

7 Press \oplus .

“Complete!” appears in the top panel display, and the station name is stored.



8 Press MENU.

Tip

- You can check the frequency in the top panel display by pressing DISPLAY repeatedly (page 48).

Viewing the station name or frequency in the top panel display

When the system is set to “FM” or “AM,” you can check the frequency using the top panel display.

Press DISPLAY.

Each time you press DISPLAY, the top panel display changes as shown.

① Station name*

② Frequency**

* This is displayed if you have entered a name for a preset station.

** Returns to the original display when several seconds have elapsed.

Using the Radio Data System (RDS)

(Except for Australian models)

What is the Radio Data System?

The Radio Data System (RDS) is a broadcasting service that allows radio stations to send additional information along with the regular program signal. This tuner offers convenient RDS features, such as station name display. RDS is available only for FM stations.*

Note

- RDS may not work properly if the station you are tuned to is not transmitting the RDS signal properly, or if the signal strength is weak.
- * Not all FM stations provide RDS service, nor do they provide the same type of services. If you are not familiar with the RDS system, check with your local radio stations for details on RDS services in your area.

Receiving RDS broadcasts

Simply select a station from the FM band.

When you tune in a station that provides RDS services, the station name* appears in the top panel display.

- * If an RDS broadcast is not received, a station name will not appear in the top panel display.

Tip

- When a station name is displayed, you can check the frequency by pressing DISPLAY repeatedly.

Advanced Settings

Controlling the Connected Sony Components with the Remote

You can control connected Sony components with the remote of this system. Some functions cannot be selected depending on the component. In that case, select them using the remote control of the component.

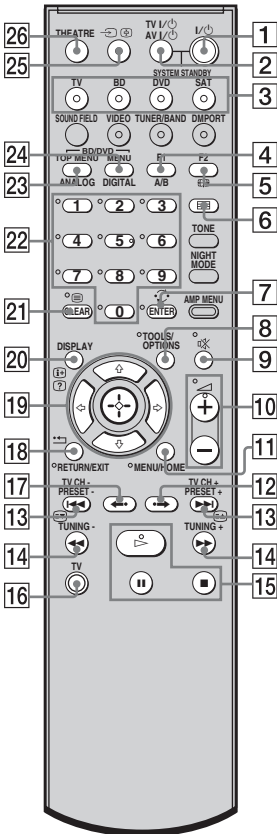

* The 5, \triangleright , and \triangleleft + buttons have a tactile dot. Use it as a guide during operation.

To control the component

1 Press one of the input buttons **3** (TV, BD, DVD, or SAT) to select the component you want to operate.

The component assigned to the selected input button becomes operable.

2 Referring to the following table, press the corresponding button for the operation.

Common operations

Remote Button	Function
2 TV I/O AV I/O (on/standby)	Turns on or off the Sony TV or audio/video components that the remote is assigned to operate. Press 1 I/O and 2 TV I/O/AV I/O at the same time to turn off the system and all other components that the remote is assigned to operate (SYSTEM STANDBY).
7 ENTER	Enters the selection.
22 Number buttons	Selects channels and tracks directly.

To control the TV

Press and hold **16** TV (orange) button while pressing the buttons with an orange dot or orange printing to control the TV.

Remote Button	Function
4 A/B	Selects the sound from the speaker for a stereo or bilingual broadcast.
5 (Screen mode)	Changes the screen format manually to suit the broadcast.
6 (Guide)	Displays the guide when you are watching analog or digital channels.
7 (Previous channel)	Returns to the previous channel watched (for more than five seconds).

Remote Button	Function
8 TOOLS/ OPTIONS	Enables you to access various viewing options and change/make adjustments according to the source and screen format.
9 (Muting)	Turns off the sound.
10	Adjusts the volume.
11 MENU/HOME	Allows you to select channels or input sources and change the settings for your TV.
13 PROG +/-//	In TV mode: Selects the next (+) or previous (-) channel. In Text mode: Selects the next () or previous () page.
18 RETURN/EXIT	Returns to the previous screen of any displayed menu.
19 , , , ,	Selects a menu item and enters the selection.
20 / (Info/Text reveal)	In digital mode: Displays brief details of the program currently being watched. In analogue mode: Displays information such as current channel number and screen format. In Text mode: Reveals hidden information (e.g. answers to a quiz).
21 (Text)	Displays Text.
22 Number buttons	Selects channels. Press 7 ENTER to change channels immediately.
23 ANALOG	Changes to analog mode.
24 DIGITAL	Changes to digital mode.
25 / (Input select/Text hold)	In TV mode: Selects input. In Analogue Text mode: Holds the current page.

Remote Button	Function
26 THEATRE	Automatically sets the optimal picture settings for watching movies, when you connect a Sony TV which is compatible with the THEATRE button. Also, the audio is automatically switched to the audio output of this system when you connect the TV and the system with HDMI connection, and the Control for HDMI function is set to on.

To control the DVD recorder/Blu-ray Disc recorder

Remote Button	Function
4 F1	Selects the HDD.
5 F2	Selects the Blu-ray Disc/DVD.
11 MENU/HOME	Displays the MENU.
12	Jumps forward while viewing recorded programs.
13	Skips chapters.
	Skips forward to the next available chapter.
14	To fast reverse or to fast forward the disc when pressed during playback.
15 (playback)/ (pause, press again to resume normal playback)/ (stop)	Play mode buttons.
17	Jumps backward while viewing live or recorded programs.
19 , , , ,	Selects a menu item and enters the selection.
23 BD/DVD TOP MENU	Displays the top menu/disc menu.
24 BD/DVD MENU	

continued

To control the DVD player/Blu-ray Disc player

Remote Button	Function
11 MENU/HOME	Displays the MENU.
12 • →	Jumps forward.
13 ◀▶▶▶	Skips chapters.
14 ◀◀▶▶	To fast reverse or to fast forward the disc when pressed during playback.
15 ▷ (playback)⏸ (pause, press again to resume normal playback)■ (stop)	Play mode buttons.
17 ← •	Jumps backward.
19 ←, ↑, ↓, →, (+/-)	Selects a menu item and enters the selection.
23 BD/DVD TOP MENU	Displays the top menu/disc menu.
24 BD/DVD MENU	

To control the HDD/DVD COMBO

Remote Button	Function
4 F1	Selects the HDD.
5 F2	Selects the DVD.
11 MENU/HOME	Displays the MENU.
12 • →	Advance.
13 ◀▶▶▶	Specifies the previous/next chapter/track.
14 ◀◀▶▶	To fast reverse or to fast forward the disc when pressed during playback.
15 ▷ (playback)⏸ (pause, press again to resume normal playback)■ (stop)	Play mode buttons.
17 ← •	Changes to replay mode.
19 ←, ↑, ↓, →, (+/-)	Moves the highlight (cursor) and selects the item.
23 BD/DVD TOP MENU	Displays the top menu/disc menu.
24 BD/DVD MENU	

To control the SAT

Remote Button	Function
6 (Guide)	Displays the guide menu.
11 MENU/HOME	Displays the MENU.
19 ←, ↑, ↓, →, (+/-)	Selects a menu item and enters the selection.

Note

- The above explanations are intended to serve as an example only. Depending on the component, the above operations may not be possible, or may operate differently than described.

Changing the Input Button Assignments of the Remote

You can change the factory settings of the input buttons to suit the components in your system. For example, if you connect a Blu-ray Disc player to the DVD jack on the system, you can set the DVD button on this remote to control the Blu-ray Disc player. You cannot assign any component other than a TV to the TV (white) button of the remote.

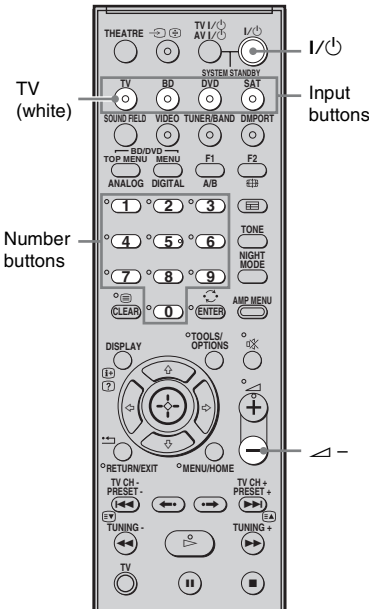

- 1** Hold down the input button you want to change the assignment of.
Example: Hold down DVD.
- 2** Referring to the following table, press the corresponding button for the category you want.
Example: Press 3.
Now you can use the DVD button to control the Blu-ray Disc player.

Categories and the corresponding buttons for BD, DVD, and SAT

Categories	Press
DVD player (command mode DVD1)	1
DVD recorder (command mode DVD3)*	2
Blu-ray Disc player (command mode BD1)**	3
Blu-ray Disc recorder (command mode BD3)	4
Euro Digital Satellite Receiver ***	7

- * The default setting of the DVD button. Sony DVD recorders are operated with a DVD1 or DVD3 setting. For details, refer to the operating instructions of the DVD recorders.
- ** The default setting of the BD button. For details on the BD1 or BD3 setting, refer to the operating instructions of the Blu-ray Disc player or Blu-ray Disc recorder.
- *** The default setting of the SAT button.

Categories and the corresponding buttons for TV

Categories	Press
TV*	5
TV**	6

- * The default setting of the TV (white) button. When this setting is selected, the audio input of the TV is switched and the image from the TV tuner is displayed on the TV screen automatically by pressing the TV (white) button.
- ** When this setting is selected, the audio input of the TV is switched automatically by pressing the TV (white) button.

To clear all remote button assignments

Press and hold \triangleleft -, I/⏻, and then press \rightarrow / \square . The remote is reset to its factory settings.

Settings and Adjustments Using the Amplifier Menu

Using the AMP menu

You can set the following items with AMP MENU on the remote.

The default settings are underlined.

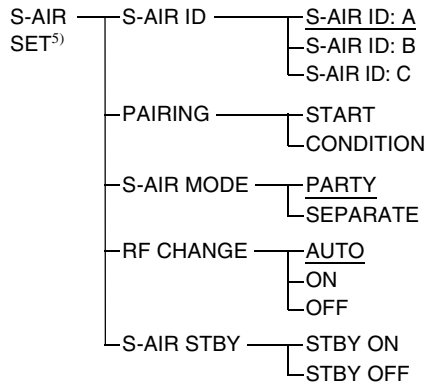
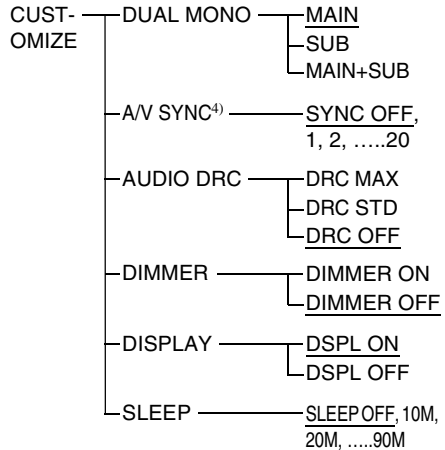
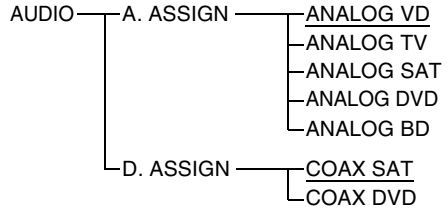
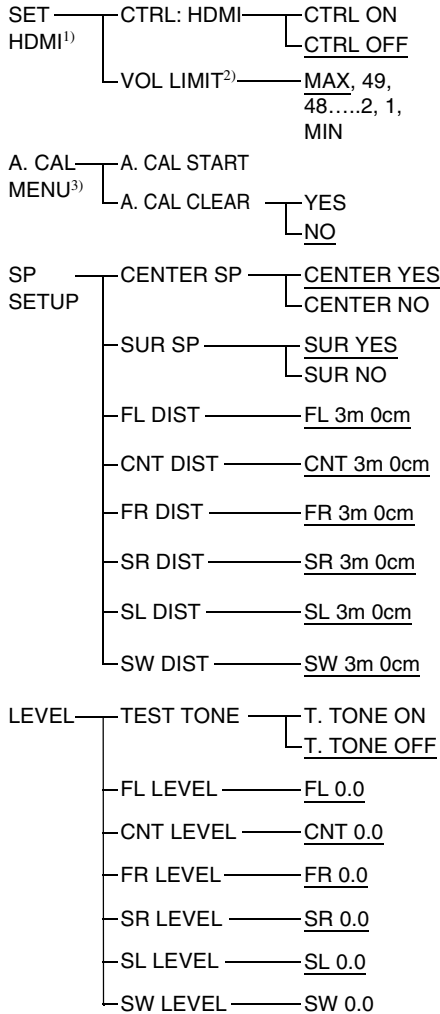

1) See ““BRAVIA” Sync features” (page 41).

2) This setting appears only when “CTRL: HDMI” is set to “CTRL ON.”

3) See “Step 6: Calibrating the Appropriate Settings Automatically” (page 24). “A. CAL CLEAR” setting appears only when the result of the Auto Calibration is saved.

4) This setting is only for the optical and coaxial input signals.

5) This setting appears only when you insert the S-AIR transmitter (not supplied).

- 1 Press AMP MENU to turn on the AMP menu.**
- 2 Press $\leftarrow/\uparrow/\downarrow/\rightarrow$ repeatedly to select the item and the setting.**
- 3 Press AMP MENU to turn off the AMP menu.**

The following pages show details for each setting.

Setting the speaker connection

To obtain the best possible surround sound, you can set the connection of the center and surround speakers.

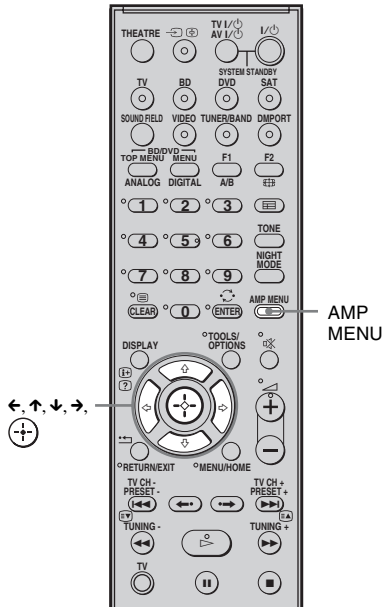

- 1 Press AMP MENU.**
- 2 Press \downarrow/\uparrow repeatedly until "SP SETUP" appears, then press \oplus or \rightarrow .**
- 3 Press \downarrow/\uparrow repeatedly to select the speaker, then press \oplus or \rightarrow .**
 - CENTER SP: selects the center speaker.
 - SUR SP: selects the surround speakers.
- 4 Press \downarrow/\uparrow to select the setting.**
 - CENTER (SUR) YES: selects when you connect the speaker(s).
 - CENTER (SUR) NO: selects when you do not connect the speaker(s).
- 5 Press AMP MENU.**

The AMP menu turns off.

Setting the speaker distance

To obtain the best possible surround sound, you can set the speaker distance from your listening position.

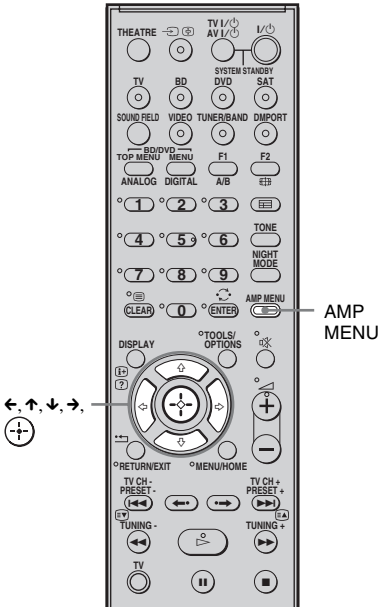

- 1 Press AMP MENU.**
- 2 Press ↓/↑ repeatedly until “SP SETUP” appears, then press ⊕ or →.**
- 3 Press ↓/↑ repeatedly to select the speaker, then press ⊕ or →.**
 - FL DIST: adjusts the front left speaker distance.
 - CNT DIST: adjusts the center speaker distance.
 - FR DIST: adjusts the front right speaker distance.
 - SR DIST: adjusts the surround right speaker distance.
 - SL DIST: adjusts the surround left speaker distance.
 - SW DIST: adjusts the subwoofer distance.

Notes

- “CNT DIST” does not appear when you set “CENTER NO” in the “SP SETUP” setting.
- “SR DIST” and “SL DIST” do not appear when you set “SUR NO” in the “SP SETUP” setting.

4 Press ↓/↑ to set the parameter, then press ⊕ or ⊖.

Default setting: 3m 0cm.

The adjustment range is 0m 0cm to 7m 0cm.

Tip

- When the result of the Auto Calibration is saved, you can adjust the speakers distance in 1 cm steps.
If the result of the Auto Calibration is not saved, you can adjust the speakers distance in 10 cm steps.

5 Repeat step 3 and 4.

6 Press AMP MENU.

The AMP menu turns off.

Setting the speaker level

You can use the test tone to adjust the level and the balance of the speakers.

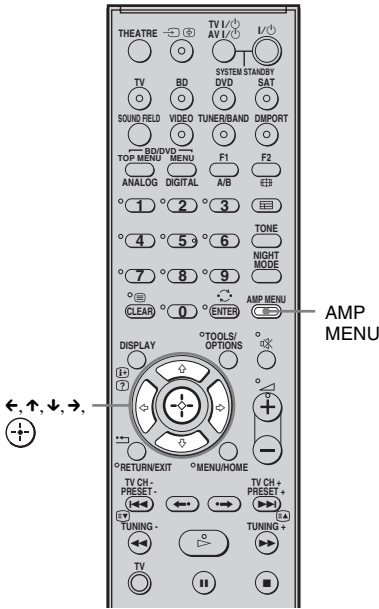

- 1** Press AMP MENU.
- 2** Press \downarrow/\uparrow repeatedly until "LEVEL" appears, then press \leftarrow or \rightarrow .
- 3** Press \downarrow/\uparrow repeatedly until "TEST TONE" appears, then press \leftarrow or \rightarrow .
- 4** Press \uparrow/\downarrow to select "T. TONE ON," then press \leftarrow .

The test tone is emitted from each speaker in sequence.

- 5** Press \downarrow/\uparrow repeatedly to select the desired speaker, then press \leftarrow or \rightarrow .

The test tone is emitted from only the speaker that is being adjusted.

- FL LEVEL: adjusts the front left speaker level.
- CNT LEVEL: adjusts the center speaker level.
- FR LEVEL: adjusts the front right speaker level.

- SR LEVEL: adjusts the surround right speaker level.
- SL LEVEL: adjusts the surround left speaker level.
- SW LEVEL: adjusts the subwoofer level.

Notes

- "CNT LEVEL" does not appear when you set "CENTER NO" in the "SP SETUP" setting.
- "SR LEVEL" and "SL LEVEL" do not appear when you set "SUR NO" in the "SP SETUP" setting.

- 6** Press \downarrow/\uparrow to adjust the speaker level, then press \leftarrow or \rightarrow .

Default setting: 0.0 (dB)

You can adjust from -6.0 (dB) to +6.0 (dB) in 0.5 (dB) steps.

Note

- If you do not adjust for a certain period, the test tone is emitted from the next speaker in sequence.

- 7** Repeat step 5 and 6 to adjust the speaker level.

- 8** After you have finished making adjustments, press \downarrow/\uparrow until "TEST TONE" appears, then press \leftarrow or \rightarrow .

- 9** Press \uparrow/\downarrow to select "T. TONE OFF," then press \leftarrow .

- 10** Press AMP MENU.

The AMP menu turns off.

Note

- The test tone signals are not output from the HDMI OUT jack.

continued

Enjoying multiplex broadcast sound (DUAL MONO)

You can enjoy multiplex broadcast sound when the system receives an AC-3 multiplex broadcast signal.

Note

- To receive AC-3 signal, you need to connect a digital satellite tuner to the system with an optical cable or coaxial cable, and set the digital output mode of the digital satellite tuner to AC-3.

- MAIN+SUB: main sound is output from the left speaker and sub sound is output from the right speaker.

5 Press AMP MENU.

The AMP menu turns off.

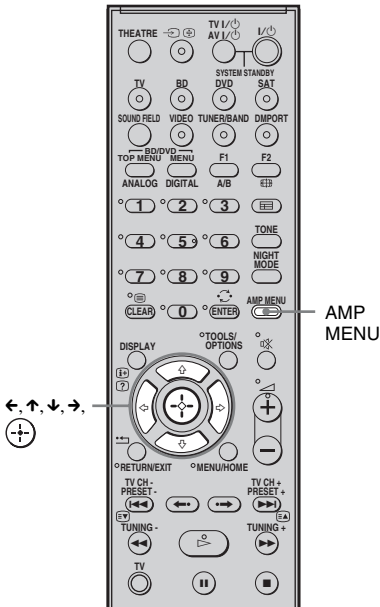

- 1 Press AMP MENU.**
- 2 Press ↓/↑ repeatedly until “CUSTOMIZE” appears, then press ⊕ or →.**
- 3 Press ↓/↑ repeatedly until “DUAL MONO” appears, then press ⊕ or →.**
- 4 Press ↓/↑ to select the sound you want.**
 - MAIN: plays back only the main channel.
 - SUB: plays back only the sub channel.

Adjusting the delay between the sound and the image (A/V SYNC)

You can delay the sound using this function when the image is slower than the sound.

Notes

- You may not be able to adjust the delay between sound and image perfectly using this function.
- This function is useful only for Dolby Digital, DTS and Linear PCM (2ch) input by optical and coaxial audio input signals.

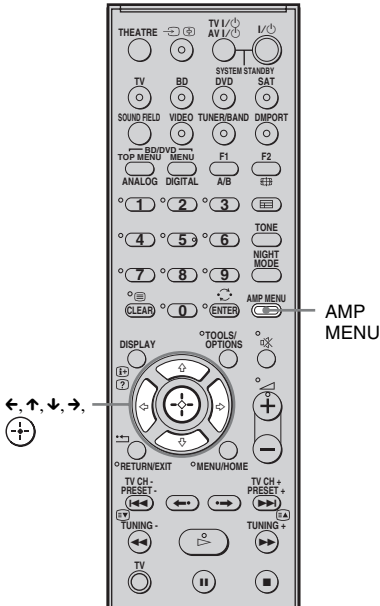

- 1 Press AMP MENU.
- 2 Press ↓/↑ repeatedly until “CUSTOMIZE” appears, then press ⊕ or →.
- 3 Press ↑/↓ repeatedly until “A/V SYNC” appears, then press ⊕ or →.
- 4 Press ↑/↓ to set the parameter.
 - SYNC OFF: does not adjust.
 - SYNC 1 – 20: adjusts from 1 (10 ms) to 20 (200 ms) in 1 (10 ms) steps.
- 5 Press AMP MENU.
The AMP menu turns off.

continued

Enjoying Dolby Digital sound at low volume (AUDIO DRC)

You can compress the dynamic range of the sound track. AUDIO DRC is useful for watching movies at low volume. AUDIO DRC only applies to Dolby Digital sources.

- 5 Press AMP MENU.
The AMP menu turns off.

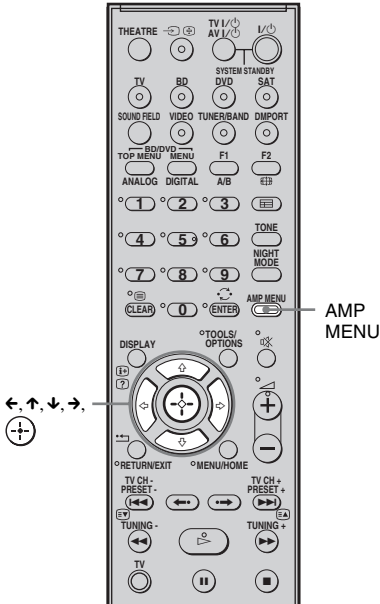

- 1 Press AMP MENU.
- 2 Press \downarrow/\uparrow repeatedly until "CUSTOMIZE" appears, then press \oplus or \rightarrow .
- 3 Press \downarrow/\uparrow repeatedly until "AUDIO DRC" appears, then press \oplus or \rightarrow .
- 4 Press \downarrow/\uparrow to select the setting.
 - DRC MAX: compresses dynamic range fully.
 - DRC STD: reproduces the sound track with the kind of dynamic range that the recording engineer intended.
 - DRC OFF: no compression of dynamic range.

Changing the brightness of the top panel display (DIMMER)

The brightness of the top panel display can be set to one of 2 levels.

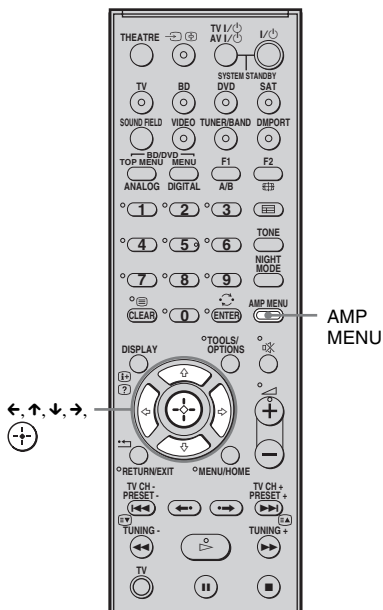

- 1 Press AMP MENU.
- 2 Press ↓/↑ repeatedly until “CUSTOMIZE” appears, then press ↺ or →.
- 3 Press ↕ repeatedly until “DIMMER” appears, then press ↻ or →.
- 4 Press ↕ to select the brightness of the top panel display.
 - DIMMER ON: low lighting.
 - DIMMER OFF: bright lighting.
- 5 Press AMP MENU.

The AMP menu turns off.

Changing the display setting (DISPLAY)

You can change the display setting.

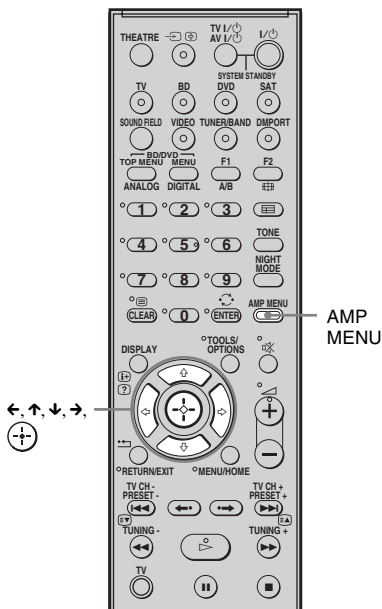

- 1 Press AMP MENU.
- 2 Press ↕ repeatedly until “CUSTOMIZE” appears, then press ↻ or →.
- 3 Press ↕ repeatedly until “DISPLAY” appears, then press ↻ or →.
- 4 Press ↕ to select the setting of the top panel display.
 - DSPL ON: the display appears all the time.
 - DSPL OFF: the display appears for a moment when you operate the system.

Note

- The display appears all the time when the muting or protection function is working, even if you set the “DISPLAY” to “DSPL OFF.”

continued



5 Press AMP MENU.

The AMP menu turns off.

Using the sleep timer (SLEEP)

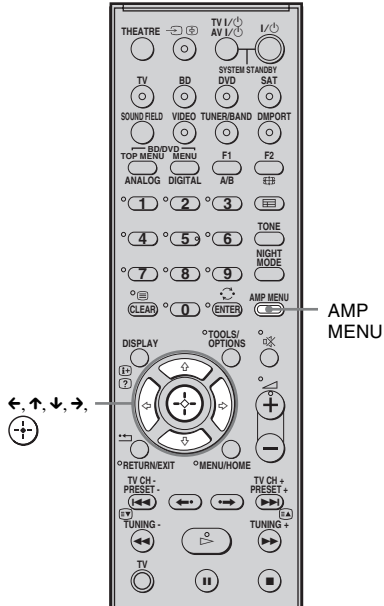
You can set the system to turn off at a preset time when you sleep listening to music. You can preset the time in 10 minutes decrements.



- 1 Press AMP MENU.
- 2 Press ↓/↑ repeatedly until "CUSTOMIZE" appears, then press  or →.
- 3 Press ↓/↑ repeatedly until "SLEEP" appears, then press  or →.
- 4 Press ↓/↑ to select the preset time.
The minutes display (the remaining time) changes as follows:

OFF ↔ 10M ↔ 20M
↑ ↓
90M ↔ 80M 30M

5 Press AMP MENU.

The AMP menu turns off.

Note

- This function is only for this system, not for the connected TV or other components.

Reassigning the audio inputs

Reassigning the analog audio input

You can reassign an audio input that has audio (analog) signal to the “TV,” “BD,” “DVD,” “SAT,” or “VIDEO” function, if it is not being used.

For example, to output the audio source for DVD player using the AUDIO IN ASSIGNABLE jacks on the subwoofer:

- Connect the analog output jacks of the DVD player to the AUDIO IN ASSIGNABLE jacks on the subwoofer.
- Assign “DVD” function to the “ANALOG DVD” in the “A. ASSIGN” setting.

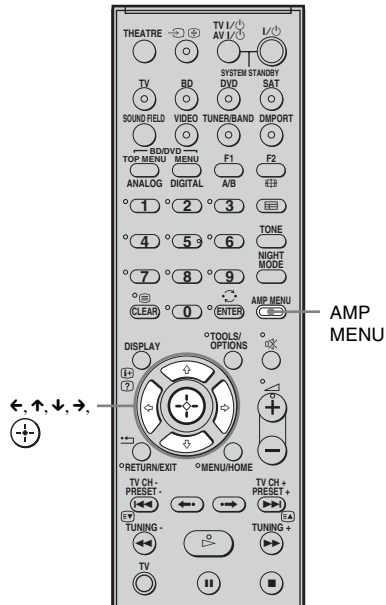

- 1 Press AMP MENU.
- 2 Press ↓/↑ repeatedly until “AUDIO” appears, then press ↻ or →.

continued

63^{GB}

3 Press \downarrow/\uparrow repeatedly until “A. ASSIGN” appears, then press \leftarrow or \rightarrow .

4 Press \downarrow/\uparrow to select the audio input you want to reassign.

- ANALOG VD: reassigns the analog audio input to the “VIDEO” function.
- ANALOG TV: reassigns the analog audio input to the “TV” function.
- ANALOG SAT: reassigns the analog audio input to the “SAT” function.
- ANALOG DVD: reassigns the analog audio input to the “DVD” function.
- ANALOG BD: reassigns the analog audio input to the “BD” function.

5 Press AMP MENU.

The AMP menu turns off.

Notes

- When images of an audio component are output, the sound may not be output. In this case, check the following:
 - Confirm the audio analog input jacks correspond with the function.
 - Reassign the function.
- You cannot use the analog audio input for the original input if it has been reassigned to another input.
- You cannot reassign the analog audio input to the “TUNER/BAND” and “DMPORT” function.

Reassigning the digital audio input

You can reassign an audio input that has coaxial (digital) signal to the “DVD” or “SAT” function, if either one function is not being used.

For example, to output the audio source for DVD player using the ASSIGNABLE COAXIAL SAT IN jack on the subwoofer:

- Connect the coaxial output jack of the DVD player to the ASSIGNABLE COAXIAL SAT IN jack on the subwoofer.
- Assign the “DVD” function to “COAX DVD” in the “D. ASSIGN” setting.

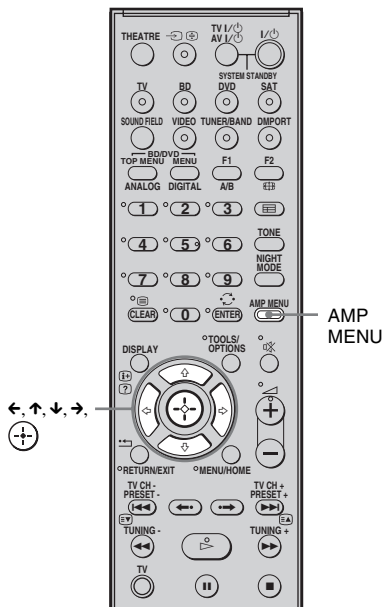

1 Press AMP MENU.

2 Press \downarrow/\uparrow repeatedly until “AUDIO” appears, then press \leftarrow or \rightarrow .

3 Press \downarrow/\uparrow repeatedly until “D. ASSIGN” appears, then press \leftarrow or \rightarrow .

Using an S-AIR Product

About S-AIR products

The system is compatible with the S-AIR function, which allows sound transmission between the subwoofer and S-AIR product (not supplied).

When you purchase the S-AIR product, you need to perform the following settings to establish the sound transmission.

There are two types of S-AIR product.

- S-AIR main unit (this subwoofer): This is for transmitting sound. You can use up to three S-AIR main units. (The number of usable S-AIR main units depends on the use environment.)
- S-AIR sub unit: This is for receiving sound.

4 Press ↓/↑ to select the audio input you want to reassign.

- COAX SAT: reassigns the coaxial audio input to the "SAT" function.
- COAX DVD: reassigns the coaxial audio input to the "DVD" function.

5 Press AMP MENU.

The AMP menu turns off.

Notes

- You cannot reassign several digital audio inputs to the same input.
- You cannot use the digital audio input for the original input if it has been reassigned to another input.
- You cannot reassign the digital audio input to the "TV," "BD," "VIDEO," "TUNER/BAND," or "DMPORT" function.

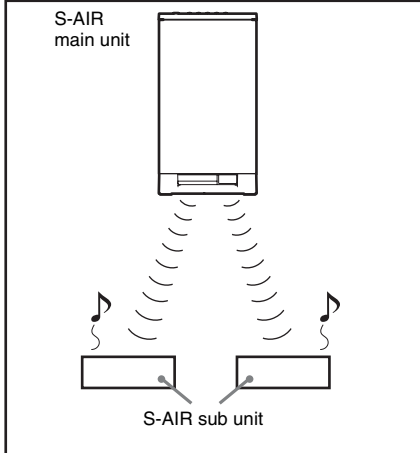

continued

Inserting the wireless transmitter/transceiver

To make use of the S-AIR function, you need to insert the wireless transmitter (not supplied) into the subwoofer and the wireless transceiver (not supplied) into the S-AIR product.

Notes

- When you insert the wireless transmitter/transceiver, make sure that the AC power cord (mains lead) is not connected to a wall outlet (mains).
- Do not touch the terminals of the wireless transmitter/transceiver.

To insert the wireless transmitter into the subwoofer

1 Remove the screws and detach the slot cover.

Bottom of the subwoofer

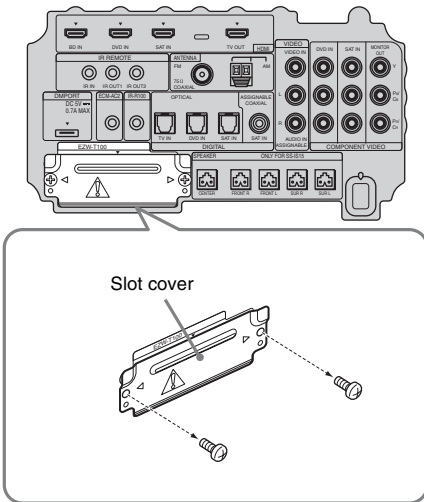

Notes

- Remove the screws from the slot cover bearing the caution mark. Do not remove other screws.
- The slot cover is no longer necessary; however, keep it after detaching.

2 Insert the wireless transmitter.

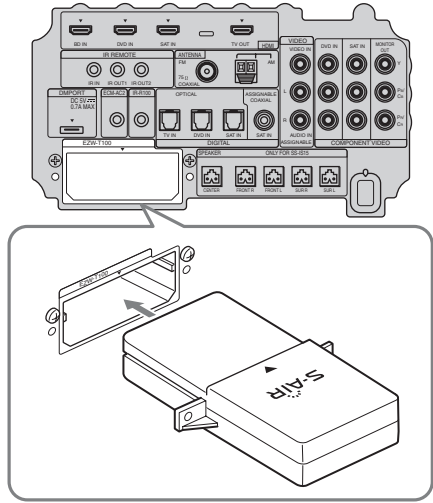

Notes

- Insert the wireless transmitter with the S-AIR logo facing up.
- Insert the wireless transmitter so that the ▼ marks are aligned.
- Do not insert other than the wireless transmitter into the EZW-T100 slot.

- 3** Make sure to use the same screws to secure the wireless transmitter.

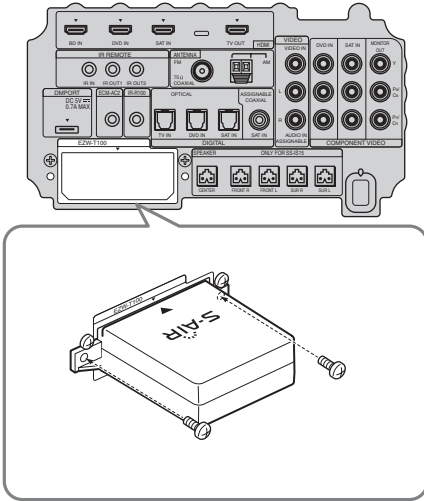

Note

- Do not use other screws to fasten the wireless transmitter.

To insert the wireless transceiver into the S-AIR product

For details on installing the wireless transceiver into the S-AIR product, refer to the operating instructions of the S-AIR product.

Establishing sound transmission between the subwoofer and the S-AIR product

To establish sound transmission, set the S-AIR products that you use.

After inserting the wireless transmitter/transceiver, connect the AC power cord (mains lead).

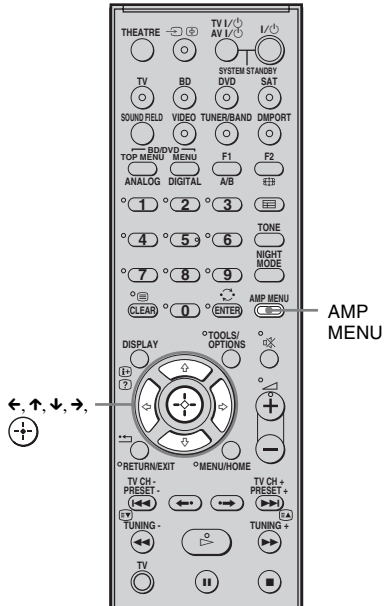

Advanced Settings

To set the ID of the subwoofer

Simply by matching the ID of the subwoofer and the S-AIR product, you can establish sound transmission. You can use multiple S-AIR products by setting a different ID for each component.

- 1 Turn on the subwoofer.**
The subwoofer turns on.
- 2 Press AMP MENU.**
- 3 Press ↓/↑ repeatedly until “S-AIR SET” appears, then press (+) or →.**

continued

4 Press \downarrow/\uparrow repeatedly until “S-AIR ID” appears, then press \oplus or \rightarrow .

5 Press \downarrow/\uparrow repeatedly to select the desired ID (A, B, or C).

6 Press AMP MENU.

The AMP menu turns off.

To set the ID of the S-AIR product

For details on setting the ID of the S-AIR product, refer to the operating instructions of the S-AIR product.

The image of established sound transmission

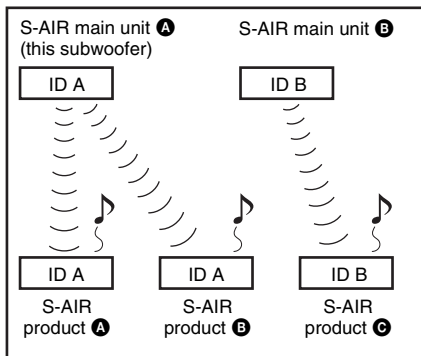

To perform the pairing operation

It is easy to set the same ID for the subwoofer and the S-AIR product to establish sound transmission. However, neighbors may also receive your system's sound if IDs are the same, or you may receive sound from neighbors. To prevent this, you can identify the subwoofer with a specific S-AIR product by performing the pairing operation.

■ When you perform pairing

Before pairing, sound transmission is established by the ID (example).

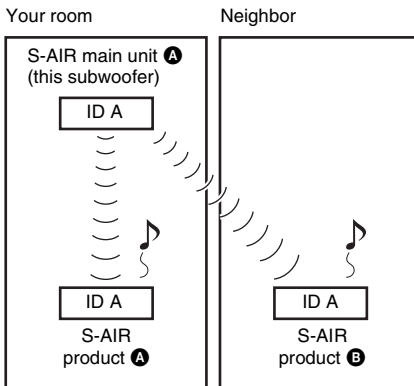

Sound transmission is established between the paired subwoofer and the S-AIR product(s).

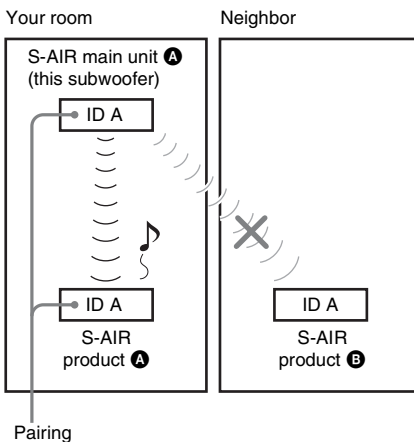



- 1** Place the S-AIR product that you want to pair near the subwoofer.
- 2** Match the IDs of the subwoofer and the S-AIR product. To set the ID of the system, see “To set the ID of the subwoofer” (page 67).

To set the ID of the S-AIR product, refer to the operating instructions of the S-AIR product.

- 3** Press AMP MENU.

4 Press ↓/↑ repeatedly until “S-AIR SET” appears, then press  or →.

5 Press ↓/↑ repeatedly until “PAIRING” appears, then press  or →.

6 Press ↓/↑ repeatedly to select the desired setting, then press  or →.

- **START:** the subwoofer starts pairing.
- **CONDITION:** you can check the current ID. When the pairing setting is not made, “NO PAIRING” appears in the top panel display.

7 **Start pairing of the S-AIR product.**

To start pairing of the S-AIR product, refer to the operating instructions of the S-AIR product.

When sound transmission is established, “COMPLETE” appears in the top panel display.

8 **Press AMP MENU.**

The AMP menu turns off.

Note

- Perform the pairing of the S-AIR product within several minutes after step 6. If you do not, pairing is canceled automatically and the “INCOMPLETE” appears in the top panel display.

To cancel pairing

Perform the ID setting of the subwoofer according to the procedure of “To set the ID of the subwoofer” (page 67). If you select a new ID (you can select the same ID as before), pairing is canceled.

Enjoying the system’s sound by using the S-AIR product

You can enjoy the system’s sound by using the S-AIR product that is compatible with the S-AIR mode. The S-AIR product can be installed anywhere, regardless of the location of the subwoofer, for enjoying the system’s sound in another room.

For details of the S-AIR product, refer to the operating instructions of the S-AIR product.

Note

- Sources with copyright protection may not be playable on S-AIR products.

1 **Set the ID of the S-AIR product to that of the subwoofer.**

To set the ID of the subwoofer, see “To set the ID of the subwoofer” (page 67).

Notes

- When you are using another S-AIR product, do not change the ID of the subwoofer. Set the ID of the S-AIR product to the same ID as the subwoofer.
- When you pair the subwoofer and another S-AIR product by the pairing operation, you need to perform pairing between the subwoofer and the S-AIR product. For details, see “To perform the pairing operation” (page 68).

continued

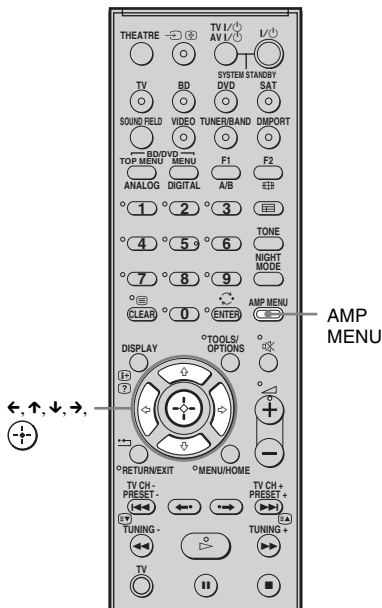

Note

- When “TUNER FM” or “TUNER AM” is selected on the subwoofer, you can only select the same band for the tuner on the S-AIR product.

6 Press AMP MENU.

The AMP menu turns off.

7 Select the desired function on the S-AIR product.

When the sound is other than 2 channel stereo, multi channel sound is down mixed to 2 channel.

8 Adjust the volume on the S-AIR product.

2 Press AMP MENU.

3 Press ↓/↑ repeatedly until “S-AIR SET” appears, then press ⏪ or →.

4 Press ↓/↑ repeatedly until “S-AIR MODE” appears, then press ⏪ or →.

5 Press ↓/↑ repeatedly to select the desired function.

- PARTY: the S-AIR product outputs sound according to function set on the subwoofer.
- SEPARATE: you can set the desired function for the S-AIR product while functions of the subwoofer do not change.
When “SEPARATE” is set, the functions you can select are “MAIN UNIT,” “TUNER FM,” “TUNER AM” and “DMPORT.”
To enjoy the same function as the subwoofer, select “MAIN UNIT.”

Changing the channel for improved sound transmission

If sound transmission is unstable, you can improve it by changing the “RF CHANGE” setting. The optimal setting differs depending on the usage environment.

In most cases, you will not need to change this setting.

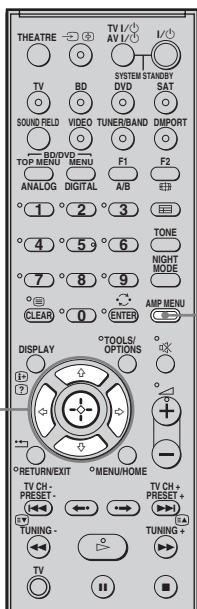

AMP MENU

- 1 Press AMP MENU.
- 2 Press \downarrow/\uparrow repeatedly until “S-AIR SET” appears, then press \leftarrow or \rightarrow .
- 3 Press \downarrow/\uparrow repeatedly to select “RF CHANGE,” then press \leftarrow or \rightarrow .
- 4 Press \downarrow/\uparrow repeatedly to select the desired setting.

- AUTO: normally select this. The subwoofer changes “RF CHANGE” to “ON” or “OFF” automatically.
- ON: the subwoofer transmits sound by searching for a better channel to transmit.

- OFF: the subwoofer transmits sound by fixing the channel to transmit.

5 Press AMP MENU.

The AMP menu turns off.

To enjoy the S-AIR product while the subwoofer is in standby mode

You can enjoy the S-AIR product while the subwoofer is in standby mode by setting “S-AIR STBY” to “STBY ON.”

When you use the timer function of the S-AIR product, set to “STBY ON” in the “S-AIR STBY” setting.

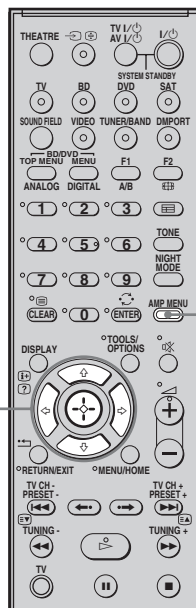

AMP MENU

- 1 Press AMP MENU.
- 2 Press \downarrow/\uparrow repeatedly until “S-AIR SET” appears, then press \leftarrow or \rightarrow .
- 3 Press \downarrow/\uparrow repeatedly to select “S-AIR STBY,” then press \leftarrow or \rightarrow .
- 4 Press \downarrow/\uparrow repeatedly to select the desired setting.

continued

- **STBY OFF:** you cannot enjoy the S-AIR product while the subwoofer is in standby mode.
- **STBY ON:** you can enjoy the S-AIR product while the subwoofer is in standby mode or turned on.

5 Press AMP MENU.

The AMP menu turns off.

Notes

- When you set “S-AIR STBY” to “STBY ON,” power consumption during standby mode increases.
- The sound of the S-AIR product may be cut off when the subwoofer is operated.

Using the IR repeater

About the IR REMOTE jacks

You can operate the subwoofer without pointing the remote toward the remote commander receiver if you connect an IR repeater (not supplied) to the IR REMOTE jack.

Use an IR repeater when you install the remote commander receiver in a place where signals from the remote cannot reach.

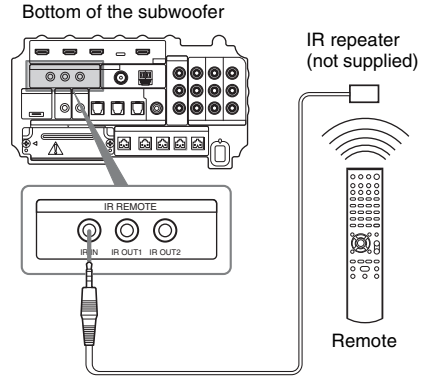

Additional Information

Troubleshooting

If you experience any of the following difficulties while using the system, use this troubleshooting guide to help remedy the problem before requesting repairs. Should any problem persist, consult your nearest Sony dealer. When bringing the system in for repairs, be sure to bring in the entire system.

General

The power is not turned on.

- Check that the AC power cord (mains lead) is connected securely.

If “PROTECTOR” and “PUSH POWER” appears alternately in the top panel display.

Press I/⏻ to turn off the system, and check the following item after “STANDBY” disappears.

- Is anything blocking the ventilation holes of the system?

After checking the above item and fixing any problems, turn on the system. If the cause of the problem cannot be found even after checking the above item, consult your nearest Sony dealer.

Dolby Digital or DTS multi channel sound is not reproduced.

- Check that the playing Blu-ray Disc, DVD, etc., is recorded in Dolby Digital or DTS format.
- Check that audio setting (settings for the audio output) of the connected component.

The surround effect cannot be obtained.

- Depending on the digital signal, the surround processing may not work (page 38).

No sound or only a very low-level sound is heard from the speakers.

- Press \triangle + and check the volume level.
- Press \boxtimes or \triangle + to cancel the muting function.

- Press SOUND FIELD and check the selected sound field.
- Depending on the source, the sound effect of the speakers may be less noticeable.

The sound comes from the center speaker only.

- Check the speaker connections and settings (page 15, 55).
- Depending on the disc, the sound may come from the center speaker only.

No sound is heard from the center speaker.

- Check the speaker connections and settings (page 15, 55).
- Set the sound field to other than “OMNI-DIRECTIONAL SOUND” (page 38).
- Depending on the source, the effect of the center speaker may be less noticeable.

No sound or only a very low-level sound is heard from the surround speakers.

- Check the speaker connections and settings (page 15, 55).
- Check the selected sound field (page 38).
- Depending on the source, the effect of the surround speakers may be less noticeable.
- A monaural or stereo (not multi channel) signal is being played.

The sound is delayed compared to the image of the TV.

- Set “A/V SYNC” to “SYNC OFF” when “A/V SYNC” is set.

Connected components

There is no sound or only a very low-level sound no matter which component is selected.

- Check that this system and components are connected correctly and securely.
- Check that both this system and the selected component are turned on.

There is no sound from the selected component.

- Check that the component is connected correctly to the audio input jacks for that component.

- Check that the cords are fully inserted into the jacks on both the component and this system.
- Check that the component is selected correctly.
- If you resume playing a disc when volume is maximum, there may be no sound. In this case, turn down the volume, turn off the system and turn on again.

Sound is interrupted or there is noise.

- Check the output audio formats supported by this system (page 76).

There is no picture or an unclear picture appears on the TV screen.

- Select the appropriate input using the input buttons.
- Set your TV to the appropriate input mode.
- Move your audio components away from the TV.
- Depending on the DIGITAL MEDIA PORT adapter, video output may not be possible.

The source image input to the HDMI jack on the subwoofer is not output from the TV.

- Check the HDMI connection.
- Depending on the playback component, you may need to set up the component. Refer to the operating instructions of each component.

There is picture on the TV screen without sound.

- Check that the audio assignable setting is correct (page 63, 64).

Control for HDMI

The Control for HDMI function does not work.

- Check the HDMI connection (page 16).
- Make sure “CTRL: HDMI” is set to “CTRL ON” in AMP menu.
- Make sure the connected component is compatible with the Control for HDMI function.
- Check the Control for HDMI settings on the connected component. For details, refer to the operating instructions of the component.

- If you change the HDMI connection, or connect/disconnect the AC power cord (main lead), or if there is a power failure, repeat the procedures of “Preparing for the “BRAVIA” Sync” (page 41).
- The system may not work correctly if you select a component that is not compatible with the Control for HDMI function on the TV side.

No sound is output from the system and the TV’s speaker.

- Check the volume of the system and the TV.
- Select the input of the system correctly.

The sound is output from both the system and the TV.

- If the Control for HDMI function is set to off, or the selected component is not compatible with the Control for HDMI function, turn off the sound of the system or the TV.

The System Power Off function does not work.

- Change the setting of the TV to turn connected components off automatically when you turn off the TV. For details, refer to the operating instructions of the TV.

An image does not appear on the TV.

- Check whether HDMI IN and HDMI OUT are connected correctly.

S-AIR function

Sound transmission is not established.

- If you use another S-AIR main unit, place it more than 8 m away from the system.
- Confirm the ID of the subwoofer and the S-AIR product (page 67).
- You performed pairing the subwoofer and another S-AIR product. Perform pairing of the desired S-AIR product (page 68).
- The S-AIR product is paired to another S-AIR product. Cancel pairing.
- Install the system away from other wireless products.
- Stop using another wireless product.

- The S-AIR product is turned off. Make sure the AC power cord (mains lead) is connected and turn on the S-AIR product.

No sound is heard from the S-AIR product.

- If you use another S-AIR main unit, place it more than 8 m away from the system.
- Confirm the ID of the subwoofer and the S-AIR product (page 67).
- Confirm the pairing setting (page 68).
- Install the S-AIR main unit and S-AIR sub unit closer together.
- Avoid use of equipment that generates electromagnetic energy, such as a microwave oven.
- Install the S-AIR main unit and S-AIR sub unit away from other wireless products.
- Stop using another wireless product.
- Change the “RF CHANGE” setting (page 71).
- Change the ID settings of the S-AIR main unit and S-AIR sub unit.
- Turn off the system and S-AIR product, then turn them on.

There is noise or the sound skips.

- If you use another S-AIR main unit, place it more than 8 m away from the system.
 - Install the S-AIR main unit and S-AIR sub unit closer together.
 - Avoid use of equipment that generates electromagnetic energy, such as a microwave oven.
 - Install the S-AIR main unit and S-AIR sub unit away from other wireless products.
 - Stop using another wireless product.
 - Change the “RF CHANGE” setting (page 71).
 - Change the ID settings of the S-AIR main unit and S-AIR sub unit.
-

Other

The remote does not function.

- Check that the subwoofer and the remote commander receiver are connected correctly and securely.
- Point the remote at the remote sensor (📡) on the remote commander receiver.
- Remove any obstacles in the path between the remote and the remote commander receiver.
- Replace both batteries in the remote with new ones, if they are weak.
- Press one of the input buttons (TV, BD, DVD, SAT, TUNER/BAND, or DMPORT) on the remote to select the component you want to operate (page 50).

The volume turns down when the output method changes from the TV speaker to the system speaker.

- The Volume Limit function is working. For details, see “Using the Volume Limit function” (page 44).
-

If the system still does not operate properly after performing the above measures, reset the system as follows:

Use buttons on the subwoofer for the operation.

1 Press I/⏻ to turn on the power.

2 Press INPUT SELECTOR, VOLUME –, I/⏻ at the same time.

“COLD RESET” appears and the system is reset. AMP menu, sound field, etc., return to the default settings.

Specifications

Formats supported by this system

Digital input formats supported by this system are as follows.

Format	Supported/Not supported
Dolby Digital	○
DTS	○
Linear PCM (2ch)*	○
Linear PCM (5.1ch, 7.1ch)* (Only on HDMI)	○
Dolby Digital Plus	×
Dolby True HD	×
DTS-HD	×

* Linear PCM accepts sampling frequencies of no more than 96 kHz.

Amplifier section

Power output (rated)

Front L / Front R (rated): 35 W + 35 W
(at 10 ohms, 1 kHz, 1 % THD)

RMS output power (reference)

Front L / Front R*: 50 W + 50 W
(at 10 ohms, 1 kHz, 10 % THD)

Center*: 50 W
(at 10 ohms, 1 kHz, 10 % THD)

Surround L / Surround R*: 50 W + 50 W
(at 10 ohms, 1 kHz, 10 % THD)

Subwoofer*: 100 W (at 4 ohms, 70 Hz, 10 % THD) + 100 W (at 4 ohms, 500 Hz, 10 % THD)

* Depending on the sound field settings and the source, there may be no sound output.

Inputs (Analog)

VIDEO Sensitivity: 700 mV
Impedance: 33 kohms

Inputs (Digital)

TV, DVD Optical
SAT Coaxial, optical

HDMI section

Connector

HDMI 19pin-standard connector

Video inputs/outputs

BD, DVD, SAT:
640 × 480p@60 Hz
720 × 480p@59.94/60 Hz
1440 × 480p@59.94/60 Hz (pixel sent 2 times)
1280 × 720p@59.94/60 Hz
1920 × 1080i@59.94/60 Hz
1920 × 1080p@59.94/60 Hz
720 × 576p@50 Hz
1440 × 576p@50 Hz (pixel sent 2 times)
1280 × 720p@50 Hz
1920 × 1080i@50 Hz
1920 × 1080p@50 Hz
1920 × 1080p@24 Hz
BD, DVD, SAT: Linear PCM 7.1ch/
Dolby Digital/ DTS

Audio inputs

Tuner section

System

PLL quartz-locked digital synthesizer

FM tuner section

Tuning range 87.5 – 108.0 MHz
(50 kHz step)

Antenna (aerial)

FM wire antenna (aerial)

Antenna (aerial) terminals

75 ohms, unbalanced

Intermediate frequency

10.7 MHz

AM tuner section

Tuning range

European models:

531 kHz – 1,602 kHz (with the interval set at 9 kHz)

Australian models:

531 kHz – 1,710 kHz (with the interval set at 9 kHz)

530 kHz – 1,710 kHz (with the interval set at 10 kHz)

Antenna (aerial)

AM loop antenna (aerial)

Intermediate frequency

450 kHz

Video section

Input

VIDEO: 1 Vp-p 75 ohms

Inputs/Outputs

COMPONENT:

Y: 1 Vp-p 75 ohms

Pb/Cb, Pr/Cr: 0.7 Vp-p 75 ohms

Speakers

Front/Center/Surround (SS-IS15)

Speaker system	Full range speaker system
Speaker unit	35 mm
Rated impedance	10 ohms
Dimensions (approx.)	45 × 55 × 40 mm (w/h/d)
Mass (approx.)	0.07 kg
Speaker cords	4.5 m × 2, 3 m × 1, 12 m × 2

Subwoofer (SA-WIS100)

Speaker system	2 Way 2 Drivers Subwoofer speaker system
Speaker unit	120 mm + 160 mm
Rated impedance	4 ohms
Dimensions (approx.)	238 × 441 × 434 mm (w/h/d)
Mass (approx.)	14.5 kg
Power requirements	220 – 240 V AC, 50/60 Hz
Power consumption	On: 115 W Standby mode: 0.3W (when “CTRL: HDMI” and “S-AIR STBY” are set to “OFF.”)
Power output	(DIGITAL MEDIA PORT)DC OUT: 5 V, 700 mA

Remote commander receiver (IR-R100)

Dimensions (approx.)	46 × 19 × 45 mm (w/h/d)
Mass (approx.)	0.15 kg

Design and specifications are subject to change without notice.



- Standby power consumption 0.3 W.
- Halogenated flame retardants are not used in the certain printed wiring boards.
- Over 85 % power efficiency of amplifier block is achieved with the full digital amplifier, S-master.

Glossary

Dolby Digital

This movie theatre sound format is more advanced than Dolby Surround Pro Logic. In this format, the surround speakers output stereo sound with an expanded frequency range, and a subwoofer channel for deep bass is independently provided. This format is also called “5.1” with the subwoofer channel designed as the 0.1 channel (since it functions only when a deep bass effect is needed). All six channels in this format are recorded separately for superior channel separation. Furthermore, since all the signals are processed digitally, less signal degradation occurs.

Dolby Pro Logic II

Dolby Pro Logic II creates five full-bandwidth output channels from 2 channel sources. This is done using an advanced, high-purity matrix surround decoder that extracts the spatial properties of the original recording without adding any new sounds or tonal colorations.

DTS

Digital audio compression technology developed by Digital Theater Systems, Inc. This technology conforms to 5.1-channel surround. This format comprises of stereo rear channel and there is discrete subwoofer channel in this format. DTS provides the same 5.1 discrete channels of high quality digital audio. The good channel separation is realized due to the all channel data being recorded discretely and processed in digitally.

HDMI

HDMI (High-Definition Multimedia Interface) is an interface that supports both video and audio on a single digital connection, allowing you to enjoy high quality digital picture and sound. The HDMI specification supports HDCP (High-bandwidth Digital Contents Protection), a copy protection technology that incorporates coding technology for digital video signals.

continued

77^{GB}

PCM (Pulse Code Modulation)

A method of converting analog audio to digital audio for easy enjoyment of digital sound.

S-AIR (Sony Audio Interactive Radio frequency)

Recent times have seen the rapid spread of DVD media, Digital Broadcasting, and other high-quality media.

To ensure that the subtle nuances of these high-quality media are transmitted with no deterioration, Sony has developed a technology called "S-AIR" for the radio transmission of digital audio signals with no compression, and has incorporated this technology into the EZWRT10/EZW-T100.

This technology transfers digital audio signals with no compression using the 2.4 GHz band range of ISM band (Industrial, Scientific, and Medical band), such as wireless LANs and Bluetooth applications.

S-master

S-master is an all-digital amplifier technology developed by Sony, which effectively minimizes the occurrence of sound fragmentation and jitter, delivering superb dialog clarity and faithful reproduction of the original sound. The compact amplifier section supports a higher power efficiency and improved thermal performance.

x.v.Colour

x.v.Colour is a more familiar term for the xvYCC standard proposed by Sony, and is a trademark of Sony. xvYCC is an international standard for color space in video.

This standard can express a wider color range than the currently used broadcast standard.

Index

A

A. ASSIGN 63
A. CAL CLEAR 28
A. CAL MENU 26, 28
A. CAL START 26
A/V SYNC 59
AMP menu 54
AUDIO 63, 64
AUDIO DRC 60
Auto Calibration 24

B

Blu-ray Disc player (recorder)
 connecting 16
“BRAVIA” Sync 41

C

CENTER SP 55
CNT DIST 56
CNT LEVEL 57
CTRL: HDMI 42
CUSTOMIZE 58, 59, 60, 61, 62

D

D. ASSIGN 64
DIGITAL MEDIA PORT
 connecting 30
DIMMER 61
DISPLAY 48, 61
DUAL MONO 58
DVD player (recorder)
 connecting 16, 19

F

FL DIST 56
FL LEVEL 57
FM Mode 47
FR DIST 56
FR LEVEL 57

H

HDMI
 connecting 16

I

Installing 7

L

LEVEL 57

M

MUTING 34

N

Naming preset stations 48
NIGHT MODE 40

P

PAIRING 68
“PlayStation 3”
 connecting 16
Presetting radio stations 46

R

Radio 47
Radio Stations 46
RDS 49
Reassigning the analog audio input 63
Reassigning the digital audio input 64
Remote
 assignments 53
 before use 6
 operating 34, 50
RF CHANGE 71

S

S-AIR 65

S-AIR ID 67

S-AIR MODE 69

S-AIR SET 67, 69, 71

S-AIR STBY 71

Satellite tuner

connecting 16, 20

SET HDMI 42, 44

SL DIST 56

SL LEVEL 57

Sleep timer 62

Sound field 38

SP SETUP 55, 56

Speakers level 57

Speakers setting 55, 56

SR DIST 56

SR LEVEL 57

SUR SP 55

SW DIST 56

SW LEVEL 57

T

TEST TONE 57

TONE 40

V

VCR

connecting 21

VOL LIMIT 44



* 3 2 9 9 2 7 0 2 1 * (2)

Free Manuals Download Website

<http://myh66.com>

<http://usermanuals.us>

<http://www.somanuals.com>

<http://www.4manuals.cc>

<http://www.manual-lib.com>

<http://www.404manual.com>

<http://www.luxmanual.com>

<http://aubethermostatmanual.com>

Golf course search by state

<http://golfingnear.com>

Email search by domain

<http://emailbydomain.com>

Auto manuals search

<http://auto.somanuals.com>

TV manuals search

<http://tv.somanuals.com>