

Wireless Microphone Package

For U30/U42/CE62/CE67 models only

The supplied CD-ROM includes the Operating Instructions for the UWP-V1/V2/V6/X7/X8 Wireless Microphone System (English, French, German, Italian, and Spanish versions) and the frequency lists in PDF format.

For more details, see "Using the CD-ROM Manual (U30/U42/CE62/CE67 Models only)" on page 34.

Operating Instructions

Before operating the unit, please read this manual thoroughly and retain it for future reference.

UWP-V1/V2/V6

UWP-X7/X8

For the UTX-B2/H2/P1 Transmitters

Owner's Record

The model and serial numbers are located at the rear or on the bottom of the unit. Record the model and serial numbers in the space provided below.

Refer to these numbers whenever you call upon your Sony dealer regarding this product.

Model No. _____

Serial No. _____

WARNING

Batteries shall not be exposed to excessive heat such as sunshine, fire or the like.

IMPORTANT

The name plate is located on the bottom and the serial number is located inside the battery compartment (UTX-P1).

AVERTISSEMENT

N'exposez pas les batteries à une chaleur excessive, au soleil ou près d'un feu par exemple.

IMPORTANT

La plaquette signalétique est posée sur le dessous de l'appareil et le numéro de série dans le logement des piles (UTX-P1).

WARNUNG

Akkus dürfen keinesfalls übermäßiger Wärmeeinwirkung ausgesetzt werden, wie z.B. Sonneneinstrahlung, Feuer o. ä.

WICHTIG

Am Boden des Geräts befindet sich das Typenschild und die Seriennummer befindet sich innen im Batteriefach (UTX-P1).

AVVERTENZA

Le batterie non devono essere esposte a fonti di calore eccessivo come luce solare diretta, fuoco, ecc.

IMPORTANTE

La targhetta con il nome si trova sul fondo e il numero di serie si trova all'interno del vano pile (UTX-P1).

ADVERTENCIA

No se deben exponer las baterías a una fuente de calor excesivo como la luz del sol, el fuego o similar.

IMPORTANTE

La placa de características se encuentra en la parte inferior y el número de serie está en el interior del compartimiento de pilas (UTX-P1).

Notice for customers in the U.S.A.

Use of Sony wireless devices is regulated by the Federal Communications Commission as described in Part 74 subpart H of the FCC regulations and users authorized thereby are required to obtain an appropriate license.

You are cautioned that any changes or modifications not expressly approved in this manual could void your authority to operate this equipment.

IMPORTANT NOTE: To comply with the FCC RF exposure compliance requirements, no change to the antenna or the device is permitted.

Any change to the antenna or the device could result in the device exceeding the RF exposure requirements and void user's authority to operate this device.

This device complies with FCC radiation exposure limits set forth for uncontrolled equipment and meets the FCC radio frequency (RF) Exposure Guidelines in Supplement C to OET65. This device has very low levels of RF energy that it is deemed to comply without testing of specific absorption ratio (SAR).

Notice for customers in Canada:

Use of Sony wireless devices is regulated by the Industry Canada as described in their Radio Standard Specification RSS-123. A licence is normally required. The local district office of Industry Canada should therefore be contacted. When the operation of the device is within the broadcast band, the licence is issued on no-interference, noprotection basis with respect to broadcast signals.

Operation is subject to the following two conditions: (1) this device may not cause interference, and (2) this device must accept any interference, including interference that may cause undesired operation of the device.

The term "IC" before the radio certification number only signifies that Industry Canada technical specifications were met.

Remarque à l'intention des utilisateurs au Canada:

L'usage des appareils sans fil Sony est réglementé par l'Industrie Canada comme décrit dans leur Cahier des Normes Radioélectriques CNR-123.

Une licence est normalement requise. Le bureau de l'Industrie Canada doit être contacté. Lorsque le fonctionnement de l'appareil respecte les limites de la bande de radiodiffusion, la licence est accordée sur la base d'une non-interférence, non-protection pour les signaux de radiodiffusion.

L'utilisation doit répondre aux deux conditions suivantes : (1) ce matériel ne doit pas provoquer de brouillage et (2) il doit accepter tout brouillage, même celui qui est susceptible d'affecter son fonctionnement.

La mention « IC: » devant le numéro de certification/ homologation signifie uniquement que les spécifications techniques d'Industrie Canada sont remplies.

Für Kunden in Deutschland (UTX-B2/H2/P1)

Entsorgungshinweis: Bitte werfen Sie nur entladene Batterien in die Sammelboxen beim Handel oder den Kommunen. Entladen sind Batterien in der Regel dann, wenn das Gerät abschaltet und signalisiert "Batterie leer" oder nach längerer Gebrauchsdauer der Batterien "nicht mehr einwandfrei funktioniert". Um sicherzugehen, kleben Sie die Batteriepole z.B. mit einem Klebestreifen ab oder geben Sie die Batterien einzeln in einen Plastikbeutel.



U.K.	470 - 862 MHz
Germany	470 - 606 MHz, 614 - 862 MHz
Norway	800 - 820 MHz
Luxembourg	470 - 862 MHz
Belgium	470 - 862 MHz
Denmark	800.100 - 819.900 MHz
France	470 - 830 MHz
Italy	470 - 854 MHz
Sweden	470 - 862 MHz
Switzerland	790 - 862 MHz
Finland	790.100 - 821.900 MHz, 854 - 862 MHz
Iceland	470 - 862 MHz
Turkey	470 - 862 MHz

Notice for customers in Europe

Hereby, Sony Corporation, declares that this UTX-B2/H2/P1 is in compliance with the essential requirements and other relevant provisions of the Directive 1999/5/EC.

For details, please access the following URL: <http://www.compliance.sony.de/>

This product is intended to be used in the following countries : United Kingdom, Germany, Norway, Luxembourg, Belgium, Denmark, France, Italy, Sweden, Switzerland, Finland, Iceland, and Turkey.

Note:

In some countries additional frequency bands may be used with the agreement of the national authority.

Notification aux clients européens

Par la présente Sony Corporation déclare que l'appareil UTX-B2/H2/P1 est conforme aux exigences essentielles et aux autres dispositions pertinentes de la directive 1999/5/CE.

Pour toute information complémentaire, veuillez consulter l'URL suivante: <http://www.compliance.sony.de/>

Ce produit est prévu pour être utilisé dans les pays suivants: Royaume-Uni, Allemagne, Norvège, Luxembourg, Belgique, Danemark, France, Italie, Suède, Suisse, Finlande, Islande et Turquie.

Remarque:

Dans certains pays, des bandes de fréquences additionnelles pourront être utilisées avec l'accord des autorités nationales.

Hinweis für die Kunden in Europa

Hiermit erklärt Sony Corporation, dass sich das Gerät UTX-B2/H2/P1 in Übereinstimmung mit den grundlegenden Anforderungen und den übrigen einschlägigen Bestimmungen der Richtlinie 1999/5/EG befindet.

Weitere Informationen erhältlich unter: <http://www.compliance.sony.de/>

Dieses Produkt ist für den Gebrauch in den folgenden Ländern vorgesehen: Vereinigtes Königreich, Deutschland, Norwegen, Luxemburg, Belgien, Dänemark, Frankreich, Italien, Schweden, Schweiz, Finnland, Island und Türkei.

Hinweis:

In manchen Ländern ist mit Genehmigung der zuständigen Behörden u.U. die Nutzung weiterer Frequenzbänder möglich.

Avvertenza per gli utilizzatori in Europa

Con la presente Sony Corporation dichiara che questo UTX-B2/H2/P1 è conforme ai requisiti essenziali ed alle altre disposizioni pertinenti stabilite dalla direttiva 1999/5/CE.

Per ulteriori dettagli, si prega di consultare il seguente URL: <http://www.compliance.sony.de/>

Questo prodotto è destinato all'uso nei seguenti paesi: Regno Unito, Germania, Norvegia, Lussemburgo, Belgio, Danimarca, Francia, Italia, Svezia, Svizzera, Finlandia, Islanda e Turchia.

Nota:

In alcuni paesi possono essere usate bande di frequenza supplementari con il permesso delle autorità nazionali.

Aviso para los clientes de Europa

Por medio de la presente Sony Corporation declara que el UTX-B2/H2/P1 cumple con los requisitos esenciales y cualesquiera otras disposiciones aplicables o exigibles de la Directiva 1999/5/CE.

Para mayor información, por favor consulte el siguiente URL: <http://www.compliance.sony.de/>

Este producto está destinado a utilizarse en los siguientes países: Reino Unido, Alemania, Noruega, Luxemburgo, Bélgica, Dinamarca, Francia, Italia, Suecia, Suiza, Finlandia, Islandia y Turquía.

Nota:

En algunos países pueden utilizarse bandas de frecuencia adicionales de acuerdo con la autoridad nacional.

Voor de klanten in Europa

Hierbij verklaart Sony Corporation dat het toestel UTX-B2/H2/P1 in

overeenstemming is met de essentiële eisen en de andere relevante bepalingen van richtlijn 1999/5/EG.

Nadere informatie kunt u vinden op:
<http://www.compliance.sony.de/>

Dit product is bedoeld om in volgende landen gebruikt te worden: Verenigd Koninkrijk, Duitsland, Noorwegen, Luxemburg, België, Denemarken, Frankrijk, Italië, Zweden, Zwitserland, Finland, IJsland en Turkije.

Opmerking:

In bepaalde landen kan er gebruik gemaakt worden van aanvullende frequentiebanden, mits toegestaan door de nationale instanties.

For kunder i Europa

Härmed intygar Sony Corporation att denna UTX-B2/H2/P1 står i överensstämmelse med de väsentliga egenskapskrav och övriga relevanta bestämmelser som framgår av direktiv 1999/5/EG.

För ytterligare information gå in på följande hemsida: <http://www.compliance.sony.de/>

Den här produkten är avsedd för användning i följande länder: Storbritannien, Tyskland, Norge, Luxembourg, Belgien, Danmark, Frankrike, Italien, Sverige, Schweiz, Finland, Island och Turkiet.

Observera:

I vissa länder kan det hända att ytterligare frekvensband används efter överenskommelse med det landets myndigheter.

Para os clientes da Europa

Sony Corporation declara que este UTX-B2/H2/P1 está conforme com os requisitos essenciais e outras disposições da Directiva 1999/5/CE.

Para mais informacoes, por favor consulte a seguinte URL:

<http://www.compliance.sony.de/>

Este produto destina-se a ser usado nos seguintes países: Reino Unido, Alemanha, Noruega, Luxemburgo, Bélgica, Dinamarca, França, Itália, Suécia, Suíça, Finlândia, Islândia e Turquia.

Obs.:

Em alguns países uma faixa adicional de frequências pode ser utilizada com autorização do governo nacional.

For kunder i Europa

Undertegnede Sony Corporation erklærer herved, at følgende udstyr UTX-B2/H2/P1 overholder de væsentlige krav og øvrige relevante krav i direktiv 1999/5/EF. For yderligere information gå ind på følgende hjemmeside:
<http://www.compliance.sony.de/>

Dette produkt er beregnet til brug i de følgende lande: Storbritannien, Tyskland, Norge, Luxembourg, Belgien, Danmark, Frankrig, Italien, Sverige, Schweiz, Finland, Island og Tyrkiet.

Bemærk:

I nogle land kan yderligere frekvensbånd blive anvendt med de nationale autoriteters samtykke.

Euroopassa oleville asiakkaille

Sony Corporation vakuuttaa täten että UTX-B2/H2/P1 tyyppinen laite on direktiivin 1999/5/EY oleellisten vaatimusten ja sitä koskevien direktiivin muiden ehtojen mukainen.

Halutessasi lisätietoja, käy osoitteessa:
<http://www.compliance.sony.de/>

Tämä tuote on tarkoitettu käytettäväksi seuraavissa maissa: Yhdistynyt kuningaskunta, Saksa, Norja, Luxemburg, Belgia, Tanska, Ranska, Italia, Ruotsi, Sveitsi, Suomi, Islanti ja Turkki.

Huom!

Joissakin maissa lisätaajuuskaistoja voidaan käyttää viranomaisten suostumuksella.

For kundene i Europa

Sony Corporation erklærer herved at utstyret UTX-B2/H2/P1 er i samsvar med de grunnleggende krav og øvrige relevante krav i direktiv 1999/5/EF.

For flere detaljer, vennligst se:
<http://www.compliance.sony.de/>

Dette produktet er ment for bruk i følgende land: Storbritannia, Tyskland, Norge, Luxemburg, Belgia, Danmark, Frankrike, Italia, Sverige, Sveits, Finland, Island og Tyrkia.

Merk:

I enkelte land kan det brukes ytterligere frekvensbånd hvis myndighetene har gitt tillatelse til dette.

Για τους πελάτες στην Ευρώπη

Με την παρούσα η Sony Corporation δηλώνει ότι UTX-B2/H2/P1 συμμορφώνεται προς της ουσιώδεις απαιτήσεις και τις λοιπές σχετικές διατάξεις της οδηγίας 1999/5/ΕΚ..

Για λεπτομέρειες παρακαλούμε όπwis ελένξετε την ακόλουθη σελίδα του διαδικτύου:
<http://www.compliance.sony.de/>

Το προϊόν προορίζεται για χρήση στις εξής χώρες: Ηνωμένο Βασίλειο, Γερμανία, Νορβηγία, Λουξεμβούργο, Βέλγιο, Δανία, Γαλλία, Ιταλία, Σουηδία, Ελβετία, Φινλανδία, Ισλανδία και Τουρκία.

Σημείωση:

Σε ορισμένες χώρες, μπορεί να χρησιμοποιούνται επιπλέον περιοχές συχνοτήτων, με τη συμφωνία της αρμόδιας εθνικής αρχής.

За клиентите в Европа

С настоящето Сони Корпорация декларира, че този UTX-B2/M2/H2 отговаря на основните изисквания и другите съответстващи клаузи на Директива 1999/5/ЕС.

Подробности може да намерите на Интернет страницата :
<http://www.compliance.sony.de/>.

Този продукт е предназначен за употреба в следните държави: Обединеното кралство, Германия, Норвегия, Люксембург, Белгия, Дания, Франция, Италия, Швеция, Швейцария, Финландия, Исландия и Турция.

Бележка:

В някои държави могат да се използват допълнителни честотни обхвати със съгласието на съответния национален орган.

Pro zákazníky v Evropě

Sony Corporation tímto prohlašuje, že tento UTX-B2/H2/P1 je ve shodě se základními požadavky a dalšími příslušnými ustanoveními směrnice 1999/5/ES.

Podrobnosti lze získat na následující URL:

<http://www.compliance.sony.de/>

Tento produkt je určen k použití v následujících zemích: Spojené království, Německo, Norsko, Lucembursko, Belgie, Dánsko, Francie, Itálie, Švédsko, Švýcarsko, Finsko, Island a Turecko.

Poznámka:

V některých zemích mohou být se souhlasem příslušného národního úřadu použita další frekvenční pásma.

Euroopa klientidele

Sony Corporation kinnitab käesolevaga seadme UTX-B2/H2/P1 vastavust 1999/5/

EÜ direktiivi pöhinöuetele ja nimetatud direktiivist tulenevatele teistele asjakohastele sätetele.
Üksikasjalikum info:
<http://www.compliance.sony.de/>.

See toode on ettenähtud kasutamiseks järgmistes riikides: Suurbritannia, Saksamaa, Norra, Luksemburg, Belgia, Taani, Prantsusmaa, Itaalia, Rootsi, Šveits, Soome, Island ja Türgi.

Märkus:

Mönedes riikides võib kokkuleppel riiklike ametitega kasutada lisa sagedusalasid.

Euröpai vásárlóink fi gyelmébe

Alulírott, Sony Corporation nyilatkozom, hogy a(z) UTX-B2/H2/P1 megfelel a vonatkozó alapvető követelményeknek és az 1999/5/EC irányelv egyéb előírásainak. További információkat a következő weboldalon találhat:
<http://www.compliance.sony.de/>

Ez a termék a következő országokban használható: Egyesült Királyság, Németország, Norvégia, Luxemburg, Belgium, Dánia, Franciaország, Olaszország, Svédország, Svájc, Finnország, Island és Törökország.

Megjegyzés:

Egyes országokban a nemzeti hatóságok jóváhagyásával további frekvenciasávok is használhatók.

Klientiem Eiropā

Ar šo Sony Corporation deklarē, ka UTX-B2/M2/H2 atbilst Direktīvas 1999/5/EK būtiskajām prasībām un citiem ar to saistītajiem noteikumiem. Plašāka informācija ir pieejama:
<http://www.compliance.sony.de/>

Šis produkts ir paredzēts lietošanai šādās valstīs: Apvienotā Karaliste, Vācija, Norvēģija, Luksemburga, Beļģija, Dānija, Francija, Itālija, Zviedrija, Šveice, Somija, Islande un Turcija.

Piezīme:

Dažās valstīs, vienojoties ar valsts instancēm, var izmantot papildu frekvenču joslas.

Klientams Europoje

Šiuo Sony Corporation deklaruoją, kad šis UTX-B2/M2/H2 atitinka esminius reikalavimus ir kitas 1999/5/EB Direktyvos nuostatas. Susipažinti su visu atitiktis deklaracijos turiniu Jūs galite interneto tinklalapyje:
<http://www.compliance.sony.de/>

Šis gaminys skirtas naudoti šiose šalyse: Jungtinėje Karalystėje, Vokietijoje, Norvegijoje, Liuksemburge, Belgijoje, Danijoje, Prancūzijoje, Italijoje, Švedijoje, Šveicarijoje, Suomijoje, Islandijoje ir Turkijoje.

Pastaba:

Kai kuriose šalyse gali būti naudojamose papildomose dažnių juostose, sutinkant valdžios institucijoms.

Dotyczy klientów z Europy

Niniejszym Sony Corporation oświadcza, że UTX-B2/H2/P1 jest zgodne z zasadniczymi wymaganiami oraz innymi stosownymi postanowieniami Dyrektywy 1999/5/WE. Szczegółowe informacje znaleźć można pod następującym adresem URL:
<http://www.compliance.sony.de/>

Ten produkt jest przeznaczony do użytku w następujących krajach: Wielkiej Brytanii, Niemczech, Norwegii, Luksemburgu, Belgii, Danii, Francji,

Włoszech, Szwecji, Szwajcarii, Finlandii, Islandii i Turcji.

Uwaga:

W niektórych krajach za zgodą władz rządowych używane mogą być dodatkowe pasma częstotliwości.

Pentru clienții din Europa

Prin prezenta, Sony Corporation declară că acest UTX-B2/H2/P1 respectă cerințele esențiale și este în conformitate cu prevederile Directivei 1995/5/EC.

Pentru detalii, vă rugăm accesați următoarea adresă:
<http://www.compliance.sony.de/>

Acest produs este destinat utilizării în următoarele țări: Regatul Unit, Germania, Norvegia, Luxemburg, Belgia, Danemarca, Franța, Italia, Suedia, Elveția, Finlanda, Islanda și Turcia.

Notă:

În anumite țări se pot utiliza benzi de frecvență suplimentare cu acordul autorității naționale de reglementare.

Pre zákazníkov v Európe

Sony Corporation týmto vyhlasuje, že UTX-B2/H2/P1 spĺňa základné požiadavky a všetky príslušné ustanovenia Smernice 1999/5/ES. Podrobnosti získate na nasledovnej webovej adrese:
<http://www.compliance.sony.de/>

Tento produkt je určený na používanie v nasledovných krajinách: Veľká Británia, Nemecko, Nórsko, Luxembursko, Belgicko, Dánsko, Francúzsko, Taliansko, Švédsko, Švajčiarsko, Fínsko, Island a Turecko.

Poznámka:

V niektorých krajinách sa môžu na základe súhlasu kompetentnej inštitúcie používať aj dodatočné frekvenčné pásma.

Za stranke v Evropi

Sony Corporation izjavlja, da je ta UTX-B2/H2/P1 v skladu z bistvenimi zahtevami in ostalimi relevantnimi določili direktive 1999/5/ES. Za podrobnosti vas naprošamo, če pogledate na URL:
<http://www.compliance.sony.de/>

Izdelek je namenjen za uporabo v naslednjih državah: Veliki Britaniji, Nemčiji, Norveški, Luksemburgu, Belgiji, Danski, Franciji, Italiji, Švedski, Švici, Finski, Islandiji in Turčiji.

Opomba:

V nekaterih državah se lahko z dovoljenjem pooblaščenih organov uporabljajo dodatna frekvenčna območja.

Note for customer in UK:

The use of this equipment is subject to individual license granted by the National Frequency Administration Authority.

Hinweis für Kunden in Großbritannien:

Der Gebrauch dieses Geräts unterliegt einer entsprechenden Lizenz von der nationalen Frequenzverwaltungsbehörde.

Merknad for kundene i Storbritannia:

Bruken av dette utstyret er underlagt en spesiell lisens som utstedes av nasjonale frekvensforvaltningsmyndigheter.

Remarque pour les clients résidant au Royaume-Uni:

L'utilisation de cet équipement est soumise à la licence individuelle accordée par les autorités d'administration des fréquences nationales.

Opmerking voor klanten in het Verenigd Koninkrijk:

Het gebruik van deze apparatuur is onderhevig aan een afzonderlijke licentie

die is verleend door de nationale autoriteit voor frequentiebeheer.

Bemærkning til kunder i Storbritannien:

Brugen af dette udstyr er underlagt individuel licens givet at teledirektoratet.

Nota per i clienti nel Regno Unito:

L'uso di questo apparecchio è soggetto ad una licenza individuale accordata dall'Autorità per l'amministrazione delle frequenze nazionali.

För kunder i Storbritannien:

Användandet av den här utrustningen sker under enskilda licenser som utfärdas av den nationella myndighet som handhar frekvenstillstånd.

Ilmoitus Yhdistyneessä kuningaskunnassa asuville asiakkaille:

Laitteiston käyttöön tarvitaan paikallisen viestintäviranomaisen myöntämä henkilökohtainen lupa.

Athugasemd fyrir viðskiptavin í Bretlandi:

Notkun þessa búnaðar þarf að vera samkvæmt leyfi frá fjarskiptayfirvöldum.

İngiltere'deki müşteriler için not:

Bu cihazın kullanımı, Ulusal Frekans Yönetimi Makamı tarafından verilen bireysel lisansa tabidir.

Note for customer in Germany:

According to German regulation this equipment can only operate in channels (specify which channels are allowed). The use of this equipment is subject to individual license granted by the National Frequency Administration Authority.

Hinweis für Kunden in Deutschland:

.Gemäß den Vorschriften in Deutschland kann dieses Gerät nur auf bestimmten Kanälen betrieben werden (zulässige Kanäle angeben). Der Gebrauch dieses Geräts unterliegt einer entsprechenden Lizenz von der nationalen Frequenzverwaltungsbehörde.

Merknad for kundene i Tyskland:

I henhold til tyske forskrifter kan dette utstyret kun brukes i kanal (angiv hvilke kanaler som er tillatt). Bruken av dette utstyret er underlagt en spesiell lisens som utstedes av nasjonale frekvensforvaltningsmyndigheter.

Remarque pour les clients résidant en Allemagne:

Conformément à la réglementation allemande, cet équipement fonctionne uniquement avec des canaux (spécifiez les canaux autorisés). L'utilisation de cet équipement est soumise à la licence individuelle accordée par les autorités d'administration des fréquences nationales.

Opmerking voor klanten in Duitsland:

Volgens de Duitse wetgeving mag deze apparatuur alleen werken in kanalen (opgeven welke kanalen zijn toegestaan). Het gebruik van deze apparatuur is onderhevig aan een afzonderlijke licentie die is verleend door de nationale autoriteit voor frequentiebeheer.

Bemærkning til kunder i Tyskland:

I henhold til tysk lovgivning kan dette udstyr kun fungere i kanaler (angiv, hvilke kanaler, der er tilladt). Brugen af dette udstyr er underlagt individuel licens givet at teledirektoratet.

Nota per i clienti in Germania:

In base alle norme vigenti in Germania, il presente apparecchio può essere utilizzato solo su canali (specificare i canali consentiti).

L'uso di questo apparecchio è soggetto ad una licenza individuale accordata dall'Autorità per l'amministrazione delle frequenze nazionali.

För kunder i Tyskland:

Enligt tysk lagstiftning får den här utrustningen endast användas med följande kanaler (ange vilka kanaler som är tillåtna). Användandet av den här utrustningen sker under enskilda licenser som utfärdas av den nationella myndighet som handhar frekvenstillstånd.

Ilmoitus Saksassa asuville asiakkaille:

Saksassa voimassa olevien määräysten mukaan tätä laitetta saa käyttää ainoastaan kanavilla (ilmoita sallitut kanavat). Laitteiston käyttöön tarvitaan paikallisen viestintäviranomaisen myöntämä henkilökohtainen lupa.

Athugasemd fyrir viðskiptavin í Þýskalandi:

Samkvæmt þýskum reglum má aðeins nota þennan búnað á rásum (tilgreinið leyfilegar rásir).

Notkun þessa búnaðar þarf að vera samkvæmt leyfi frá fjarskiptayfirvöldum.

Almanya'daki müşteriler için not:

Almanya mevzuatlarına göre, bu cihaz yalnızca (izin verilen kanalları belirtin) kanallarda çalışabilir.

Bu cihazın kullanımı, Ulusal Frekans Yönetimi Makamı tarafından verilen bireysel lisansa tabidir.

Note for customer in Norway:

According to Norwegian regulation this equipment can only operate in channels (specify which channels are allowed) with a maximum RF output power of 20mW.

The use of this equipment is subject to individual license granted by the National Frequency Administration Authority.

Hinweis für Kunden in Norwegen:

Gemäß den Vorschriften in Norwegen kann dieses Gerät nur auf bestimmten Kanälen betrieben werden (zulässige Kanäle angeben), und zwar mit einer maximalen HF-Ausgangsleistung von 20 mW.

Der Gebrauch dieses Geräts unterliegt einer entsprechenden Lizenz von der nationalen Frequenzverwaltungsbehörde.

Merknad for kundene i Norge:

I henhold til norske forskrifter kan dette utstyret kun brukes i kanal (angi hvilke kanaler som er tillatt) med maksimal RF-utgangseffekt på 20 mW.

Bruken av dette utstyret er underlagt en spesiell lisens som utstedes av nasjonale frekvensforvaltningsmyndigheter.

Remarque pour les clients résidant en Norvège:

Conformément à la réglementation norvégienne, cet équipement fonctionne uniquement avec des canaux (spécifiez les canaux autorisés) ayant une puissance de sortie RF maximale de 20 mW.

L'utilisation de cet équipement est soumise à la licence individuelle accordée par les autorités d'administration des fréquences nationales.

Opmerking voor klanten in Noorwegen:

Volgens de Noorse wetgeving mag deze apparatuur alleen werken in kanalen (opgeven welke kanalen zijn toegestaan) met een maximaal RF-uitgangsvermogen van 20 mW.

Het gebruik van deze apparatuur is onderhevig aan een afzonderlijke licentie die is verleend door de nationale autoriteit voor frequentiebeheer.

Bemærkning til kunder i Norge:

I henhold til norsk lovgivning kan dette udstyr kun fungere i kanaler (angiv, hvilke kanaler, der er tilladt) med en maksimal RF-udgangseffekt på 20 mW.

Brugen af dette udstyr er underlagt individuel licens givet af teledirektoratet.

Nota per i clienti in Norvegia:

In base alle norme vigenti in Norvegia, il presente apparecchio può essere utilizzato solo su canali (specificare i canali consentiti) con una potenza di uscita RF massima di 20mW.

L'uso di questo apparecchio è soggetto ad una licenza individuale accordata dall'Autorità per l'amministrazione delle frequenze nazionali.

För kunder i Norge:

Enligt norsk lagstiftning får den här utrustningen endast användas med följande kanaler (ange vilka kanaler som är tillåtna) med en maximal RF-ut effekt på 20 mW. Användandet av den här utrustningen sker under enskilda licenser som utfärdas av den nationella myndighet som handhar frekvenstillstånd.

Ilmoitus Norjassa asuville asiakkaille:

Norjassa voimassa olevien mää räysten mukaan tätä laitetta saa käyttää ainoastaan kanavilla (ilmoita sallitut kanavat) ja siten, että RF-lähetysten enimmäisteho on 20 mW.

Laitteiston käyttöön tarvitaan paikallisen viestintäviranomaisen myöntämä henkilökohtainen lupa.

Athugasemd fyrir viðskiptavin í Noregi:

Samkvæmt norskum reglum má aðeins nota þennan búnað á rásum (tilgreinið leyfilegar rásir) og er hámarkssendistyrkur útværpsþylgjanna 20mW.

Notkun þessa búnaðar þarf að vera samkvæmt leyfi frá fjarskiptayfirvöldum.

Norveç'teki müşteriler için not:

Norveç mevzuatlarına göre, bu cihaz yalnızca RF çıkış gücü maksimum 20mW olan (izin verilen kanalları belirtin) kanallarda çalışabilir.

Bu cihazın kullanımını, Ulusal Frekans Yönetimi Makamı tarafından verilen bireysel lisansa tabidir.

Note for customer in Luxembourg:

The use of this equipment is subject to individual license granted by the National Frequency Administration Authority.

Hinweis für Kunden in Luxembourg:

Der Gebrauch dieses Geräts unterliegt einer entsprechenden Lizenz von der nationalen Frequenzverwaltungsbehörde.

Merknad for kundene i Luxembourg:

Bruken av dette utstyret er underlagt en spesiell lisens som utstedes av nasjonale frekvensforvaltningsmyndigheter.

Remarque pour les clients résidant au Luxembourg:

L'utilisation de cet équipement est soumise à la licence individuelle accordée par les autorités d'administration des fréquences nationales.

Opmerking voor klanten in Luxembourg:

Het gebruik van deze apparatuur is onderhevig aan een afzonderlijke licentie die is verleend door de nationale autoriteit voor frequentiebeheer.

Bemærkning til kunder i Luxembourg:

Brugen af dette udstyr er underlagt individuel licens givet af teledirektoratet.

Nota per i clienti in

Lussemburgo:

L'uso di questo apparecchio è soggetto ad una licenza individuale accordata dall'Autorità per l'amministrazione delle frequenze nazionali.

För kunder i Luxemburg:

Användandet av den här utrustningen sker under enskilda licenser som utfärdas av den nationella myndighet som handhar frekvenstillstånd.

Ilmoitus Luxemburgissa asuville asiakkaille:

Laitteiston käyttöön tarvitaan paikallisen viestintäviranomaisen myöntämä henkilökohtainen lupa.

Athugasemd fyrir viðskiptavin í Lúxemborg:

Notkun þessa búnaðar þarf að vera samkvæmt leyfi frá fjarskiptayfirvöldum.

Lüksemburg'taki müşteriler için not:

Bu cihazın kullanımı, Ulusal Frekans Yönetimi Makamı tarafından verilen bireysel lisansa tabidir.

Note for customer in Belgium:

The use of this equipment is subject to individual license granted by the National Frequency Administration Authority.

Hinweis für Kunden in Belgien:

Der Gebrauch dieses Geräts unterliegt einer entsprechenden Lizenz von der nationalen Frequenzverwaltungsbehörde.

Merknad for kundene i Belgia:

Bruken av dette utstyret er underlagt en spesiell lisens som utstedes av nasjonale frekvensforvaltningsmyndigheter.

Remarque pour les clients résidant en Belgique:

L'utilisation de cet équipement est soumise à la licence individuelle accordée par les

autorités d'administration des fréquences nationales.

Opmerking voor klanten in België:

Het gebruik van deze apparatuur is onderhevig aan een afzonderlijke licentie die is verleend door de nationale autoriteit voor frequentiebeheer.

Bemærkning til kunder i Belgien:

Brugen af dette udstyr er underlagt individuel licens givet af telemyndighederne.

Nota per i clienti in Belgio:

L'uso di questo apparecchio è soggetto ad una licenza individuale accordata dall'Autorità per l'amministrazione delle frequenze nazionali.

För kunder i Belgien:

Användandet av den här utrustningen sker under enskilda licenser som utfärdas av den nationella myndighet som handhar frekvenstillstånd.

Ilmoitus Belgiassa asuville asiakkaille:

Laitteiston käyttöön tarvitaan paikallisen viestintäviranomaisen myöntämä henkilökohtainen lupa.

Athugasemd fyrir viðskiptavin í Belgíu:

Notkun þessa búnaðar þarf að vera samkvæmt leyfi frá fjarskiptayfirvöldum.

Belçika'daki müşteriler için not:

Bu cihazın kullanımı, Ulusal Frekans Yönetimi Makamı tarafından verilen bireysel lisansa tabidir.

Note for customer in Denmark:

According to Danish regulation this equipment can only operate in channels (specify which channels are allowed).

The use of this equipment is subject to individual license granted by the National Frequency Administration Authority.

Hinweis für Kunden in Dänemark:

Gemäß den Vorschriften in Dänemark kann dieses Gerät nur auf bestimmten Kanälen betrieben werden (zulässige Kanäle angeben).

Der Gebrauch dieses Geräts unterliegt einer entsprechenden Lizenz von der nationalen Frequenzverwaltungsbehörde.

Merknad for kundene i Danmark:

I henhold til danske forskrifter kan dette udstyret kun bruges i kanal (angi hvilke kanaler som er tilladt).

Bruken av dette utstyret er underlagt en spesiell lisens som utstedes av nasjonale frekvensforvaltningsmyndigheter.

Remarque pour les clients résidant au Danemark:

Conformément à la réglementation danoise, cet équipement fonctionne uniquement avec des canaux (spécifiez les canaux autorisés).

L'utilisation de cet équipement est soumise à la licence individuelle accordée par les autorités d'administration des fréquences nationales.

Opmerking voor klanten in Denemarken:

Volgens de Deense wetgeving mag deze apparatuur alleen werken in kanalen (opgeven welke kanalen zijn toegestaan). Het gebruik van deze apparatuur is onderhevig aan een afzonderlijke licentie die is verleend door de nationale autoriteit voor frequentiebeheer.

Bemærkning til kunder i Danmark

I henhold til dansk lovgivning kan dette udstyr kun fungere i kanaler (angiv, hvilke kanaler, der er tilladt).

Brugen af dette udstyr er underlagt til individuel licens givet af telemyndighederne.

Nota per i clienti in Danimarca:

In base alle norme vigenti in Danimarca, il presente apparecchio può essere utilizzato solo su canali (specificare i canali consentiti).

L'uso di questo apparecchio è soggetto ad una licenza individuale accordata dall'Autorità per l'amministrazione delle frequenze nazionali.

För kunder i Danmark:

Enligt dansk lagstiftning får den här utrustningen endast användas med följande kanaler (ange vilka kanaler som är tillåtna). Användandet av den här utrustningen sker under enskilda licenser som utfärdas av den nationella myndighet som handhar frekvenstillstånd.

Ilmoitus Tanskassa asuville asiakkaille:

Tanskassa voimassa olevien määrysten mukaan tätä laitetta saa käyttää ainoastaan kanavilla (ilmoita sallitut kanavat).

Laitteiston käyttöön tarvitaan paikallisen viestintäviranomaisen myöntämä henkilökohtainen lupa.

Athugasemd fyrir viðskiptavin í Danmörku:

Samkvæmt dönskum reglum má aðeins nota þennan búnað á rásum (tilgreinið leyfilegar rásir).

Notkun þessa búnaðar þarf að vera samkvæmt leyfi frá fjarskiptayfirvöldum.

Danimarka'daki müşteriler için not:

Danimarka mevzuatlarına göre, bu cihaz yalnızca (izin verilen kanalları belirtin) kanallarda çalışabilir.

Bu cihazın kullanımı, Ulusal Frekans Yönetimi Makamı tarafından verilen bireysel lisansa tabidir.

Note for customer in Italy:

According to Italian regulation this equipment can only operate in channels (specify which channels are allowed). The use of this equipment is subject to individual license granted by the National Frequency Administration Authority.

Hinweis für Kunden in Italien:

Gemäß den Vorschriften in Italien kann dieses Gerät nur auf bestimmten Kanälen betrieben werden (zulässige Kanäle angeben). Der Gebrauch dieses Geräts unterliegt einer entsprechenden Lizenz von der nationalen Frequenzverwaltungsbehörde.

Merknad for kundene i Italia:

I henhold til italienske forskrifter kan dette utstyret kun brukes i kanal (angi hvilke kanaler som er tillatt). Bruken av dette utstyret er underlagt en spesiell lisens som utstedes av nasjonale frekvensforvaltningsmyndigheter.

Remarque pour les clients résidant en Italie:

Conformément à la réglementation italienne, cet équipement fonctionne uniquement avec des canaux (spécifiez les canaux autorisés). L'utilisation de cet équipement est soumise à la licence individuelle accordée par les autorités d'administration des fréquences nationales.

Opmerking voor klanten in Italië:

Volgens de Italiaanse wetgeving mag deze apparatuur alleen werken in kanalen (opgeven welke kanalen zijn toegestaan). Het gebruik van deze apparatuur is onderhevig aan een afzonderlijke licentie die is verleend door de nationale autoriteit voor frequentiebeheer.

Bemærkning til kunder i Italien:

I henhold til italiensk lovgivning kan dette udstyr kun fungere i kanaler (angiv, hvilke kanaler, der er tilladt).

Brugen af dette udstyr er underlagt individuel licens givet af telemyndighederne.

Nota per i clienti in Italia:

In base alle norme vigenti in Italia, il presente apparecchio può essere utilizzato solo su canali (specificare i canali consentiti). L'uso di questo apparecchio è soggetto ad una licenza individuale accordata dall'Autorità per l'amministrazione delle frequenze nazionali.

För kunder i Italien:

Enligt italiensk lagstiftning får den här utrustningen endast användas med följande kanaler (ange vilka kanaler som är tillåtna). Användandet av den här utrustningen sker under enskilda licenser som utfärdas av den nationella myndighet som handhar frekvenstillstånd.

Ilmoitus Italiassa asuville asiakkaille:

Italiassa voimassa olevien määräysten mukaan tätä laitetta saa käyttää ainoastaan kanavilla (ilmoita sallitut kanavat). Laitteiston käyttöön tarvitaan paikallisen viestintäviranomaisen myöntämä henkilökohtainen lupa.

Athugasemd fyrir viðskiptavin á Ítalíu:

Samkvæmt ítölskum reglum má aðeins nota þennan búnað á rásum (tilgreinið leyfilegar rásir). Notkun þessa búnaðar þarf að vera samkvæmt leyfi frá fjarskiptayfirvöldum.

İtalya'daki müşteriler için not:

İtalya mevzuatlarına göre, bu cihaz yalnızca (izin verilen kanalları belirtin) kanallarda çalışabilir. Bu cihazın kullanımı, Ulusal Frekans Yönetimi Makamı tarafından verilen bireysel lisansa tabidir.

Note for customer in Sweden:

According to Swedish regulation this equipment can only operate in channels (specify which channels are allowed). The use of this equipment is subject to individual license granted by the National Frequency Administration Authority.

Hinweis für Kunden in Schweden:

Gemäß den Vorschriften in Schweden kann dieses Gerät nur auf bestimmten Kanälen betrieben werden (zulässige Kanäle angeben).

Der Gebrauch dieses Geräts unterliegt einer entsprechenden Lizenz von der nationalen Frequenzverwaltungsbehörde.

Merknad for kundene i Sverige:

I henhold til svenske forskrifter kan dette utstyret kun brukes i kanal (angi hvilke kanaler som er tillatt).

Bruken av dette utstyret er underlagt en spesiell lisens som utstedes av nasjonale frekvensforvaltningsmyndigheter.

Remarque pour les clients résidant en Suède:

Conformément à la réglementation suédoise, cet équipement fonctionne uniquement avec des canaux (spécifiez les canaux autorisés).

L'utilisation de cet équipement est soumise à la licence individuelle accordée par les autorités d'administration des fréquences nationales.

Opmerking voor klanten in Zweden:

Volgens de Zweedse wetgeving mag deze apparatuur alleen werken in kanalen (opgeven welke kanalen zijn toegestaan). Het gebruik van deze apparatuur is onderhevig aan een afzonderlijke licentie die is verleend door de nationale autoriteit voor frequentiebeheer.

Bemærkning til kunder i Sverige:

I henhold til svensk lovgivning kan dette udstyr kun fungere i kanaler (angiv, hvilke kanaler, der er tilladt).

Bruget af dette udstyr er underlagt individuel licens givet af telemyndighederne.

Nota per i clienti in Svezia:

In base alle norme vigenti in Svezia, il presente apparecchio può essere utilizzato solo su canali (specificare i canali consentiti).

L'uso di questo apparecchio è soggetto ad una licenza individuale accordata dall'Autorità per l'amministrazione delle frequenze nazionali.

För kunder i Sverige:

Enligt svensk lagstiftning får den här utrustningen endast användas med följande kanaler (ange vilka kanaler som är tillåtna). Användandet av den här utrustningen sker under enskilda licenser som utfärdas av den nationella myndighet som handhar frekvenstillstånd.

Ilmoitus Ruotsissa asuville asiakkaille:

Ruotsissa voimassa olevien määräysten mukaan tätä laitetta saa käyttää ainoastaan kanavilla (ilmoita sallitut kanavat). Laitteiston käyttöön tarvitaan paikallisen viestintäviranomaisen myöntämä henkilökohtainen lupa.

Athugasemd fyrir viðskiptavin í Svíþjóð:

Samkvæmt sænskum reglum má aðeins nota þennan búnað á rásum (tilgreinið leyfilegar rásir).

Notkun þessa búnaðar þarf að vera samkvæmt leyfi frá fjarskiptayfirvöldum.

İsveç'teki müşteriler için not:

İsveç mevzuatlarına göre, bu cihaz yalnızca (izin verilen kanalları belirtin) kanallarda çalışabilir.

Bu cihazın kullanımı, Ulusal Frekans Yönetimi Makamı tarafından verilen bireysel lisansa tabidir.

Note for customer in Switzerland:

According to Swiss regulation this equipment can only operate in channels (specify which channels are allowed). The use of this equipment is subject to individual license granted by the National Frequency Administration Authority.

Hinweis für Kunden in der Schweiz:

Gemäß den Vorschriften in der Schweiz kann dieses Gerät nur auf bestimmten Kanälen betrieben werden (zulässige Kanäle angeben).

Der Gebrauch dieses Geräts unterliegt einer entsprechenden Lizenz von der nationalen Frequenzverwaltungsbehörde.

Merknad för kundene i Sveits:

I henhold til sveitsiske forskrifter kan dette utstyret kun brukes i kanal (angi hvilke kanaler som er tillatt).

Bruken av dette utstyret er underlagt en spesiell lisens som utstedes av nasjonale frekvensforvaltningsmyndigheter.

Remarque pour les clients résidant en Suisse:

Conformément à la réglementation suisse, cet équipement fonctionne uniquement avec des canaux (spécifiez les canaux autorisés).

L'utilisation de cet équipement est soumise à la licence individuelle accordée par les autorités d'administration des fréquences nationales.

Opmerking voor klanten in Zwitserland:

Volgens de Zwitserse wetgeving mag deze apparatuur alleen werken in kanalen (opgeven welke kanalen zijn toegestaan). Het gebruik van deze apparatuur is onderhevig aan een afzonderlijke licentie die is verleend door de nationale autoriteit voor frequentiebeheer.

Bemærkning til kunder i Schweiz:

I henhold til schweizisk lovgivning kan dette udstyr kun fungere i kanaler (angiv, hvilke kanaler, der er tilladt). Brugen af dette udstyr er underlagt individuel licens givet af teledmyndighederne.

Nota per i clienti in Svizzera:

In base alle norme vigenti in Svizzera, il presente apparecchio può essere utilizzato solo su canali (specificare i canali consentiti).

L'uso di questo apparecchio è soggetto ad una licenza individuale accordata dall'Autorità per l'amministrazione delle frequenze nazionali.

För kunder i Schweiz:

Enligt schweizisk lagstiftning får den här utrustningen endast användas med följande kanaler (ange vilka kanaler som är tillåtna). Användandet av den här utrustningen sker under enskilda licenser som utfärdas av den nationella myndighet som handhar frekvenstillstånd.

Ilmoitus Sveitsissä asuville asiakkaille:

Sveitsissä voimassa olevien määräysten mukaan tätä laitetta saa käyttää ainoastaan kanavilla (ilmoita sallitut kanavat).

Laitteiston käyttöön tarvitaan paikallisen viestintäviranomaisen myöntämä henkilökohtainen lupa.

Athugasemd fyrir viðskiptavin í Svíss:

Samkvæmt svissneskum reglum má aðeins nota þennan búnað á rásam (tilgreinið leyfilegar rásir).

Notkun þessa búnaðar þarf að vera samkvæmt leyfi frá fjarskiptayfirvöldum.

İsviçre'deki müşteriler için not:

İsviçre mevzuatlarına göre, bu cihaz yalnızca (izin verilen kanalları belirtin) kanallarda çalışabilir.

Bu cihazın kullanımı, Ulusal Frekans Yönetimi Makamı tarafından verilen bireysel lisansa tabidir.

Note for customer in Finland:

According to Finnish regulation this equipment can only operate in channels (specify which channels are allowed).

The use of this equipment is subject to individual license granted by the National Frequency Administration Authority.

Hinweis für Kunden in Finnland:

Gemäß den Vorschriften in Finnland kann dieses Gerät nur auf bestimmten Kanälen betrieben werden (zulässige Kanäle angeben).

Der Gebrauch dieses Geräts unterliegt einer entsprechenden Lizenz von der nationalen Frequenzverwaltungsbehörde.

Merknad for kundene i Finland:

I henhold til finske forskrifter kan dette utstyret kun brukes i kanal (angi hvilke kanaler som er tillatt).

Bruken av dette utstyret er underlagt en spesiell lisens som utstedes av nasjonale frekvensforvaltningsmyndigheter.

Remarque pour les clients résidant en Finlande

Conformément à la réglementation finlandaise, cet équipement fonctionne uniquement avec des canaux (spécifiez les canaux autorisés).

L'utilisation de cet équipement est soumise à la licence individuelle accordée par les autorités d'administration des fréquences nationales.

Opmerking voor klanten in Finland:

Volgens de Finse wetgeving mag deze apparatuur alleen werken in kanalen (opgeven welke kanalen zijn toegestaan). Het gebruik van deze apparatuur is onderhevig aan een afzonderlijke licentie die is verleend door de nationale autoriteit voor frequentiebeheer.

Bemærkning til kunder i Finland:

I henhold til finsk lovgivning kan dette udstyr kun fungere i kanaler (angiv, hvilke kanaler, der er tilladt).

Bruget af dette udstyr er underlagt individuel licens givet af telemyndighederne.

Nota per i clienti in Finlandia:

In base alle norme vigenti in Finlandia, il presente apparecchio può essere utilizzato solo su canali (specificare i canali consentiti).

L'uso di questo apparecchio è soggetto ad una licenza individuale accordata dall'Autorità per l'amministrazione delle frequenze nazionali.

För kunder i Finland:

Enligt finsk lagstiftning får den här utrustningen endast användas med följande kanaler (ange vilka kanaler som är tillåtna). Användandet av den här utrustningen sker under enskilda licenser som utfärdas av den nationella myndighet som handhar frekvenstillstånd.

Ilmoitus suomalaisille kuluttajille:

Suomessa voimassa olevien määräysten mukaan tätä laitetta saa käyttää ainoastaan kanavilla (ilmoita sallitut kanavat).

Laitteiston käyttöön tarvitaan Viestintäviraston myöntämä henkilökohtainen lupa.

Athugasemd fyrir viðskiptavin í Finnlandi:

Samkvæmt finnskum reglum má aðeins nota þennan búnað á rásum (tilgreinið leyfilegar rásir).

Notkun þessa búnaðar þarf að vera samkvæmt leyfi frá fjarskiptayfirvöldum.

Finlandiya'daki müşteriler için not:

Finlandiya mevzuatlarına göre, bu cihaz yalnızca (izin verilen kanalları belirtin) kanallarda çalışabilir.

Bu cihazın kullanımı, Ulusal Frekans Yönetimi Makamı tarafından verilen bireysel lisansa tabidir.

Note for customer in Iceland:

The use of this equipment is subject to individual license granted by the National Frequency Administration Authority.

Hinweis für Kunden in Island:

Der Gebrauch dieses Geräts unterliegt einer entsprechenden Lizenz von der nationalen Frequenzverwaltungsbehörde.

Merknad for kundene på Island:

Bruken av dette utstyret er underlagt en spesiell lisens som utstedes av nasjonale frekvensforvaltningsmyndigheter.

Remarque pour les clients résidant en Islande:

L'utilisation de cet équipement est soumise à la licence individuelle accordée par les autorités d'administration des fréquences nationales.

Opmerking voor klanten in IJsland:

Het gebruik van deze apparatuur is onderhevig aan een afzonderlijke licentie die is verleend door de nationale autoriteit voor frequentiebeheer.

Bemærkning til kunder i Island:

Brugen af dette udstyr er underlagt individuel licens givet at telemyndighederne.

Nota per i clienti in Islanda:

L'uso di questo apparecchio è soggetto ad una licenza individuale accordata dall'Autorità per l'amministrazione delle frequenze nazionali.

För kunder i Island:

Användandet av den här utrustningen sker under enskilda licenser som utfärdas av den nationella myndighet som handhar frekvenstillstånd.

Ilmoitus Islannissa asuville asiakkaille:

Laitteiston käyttöön tarvitaan paikallisen viestintäviranomaisen myöntämä henkilökohtainen lupa.

Athugasemd fyrir viðskiptavin á Íslandi:

Notkun þessa búnaðar þarf að vera samkvæmt leyfi frá fjarskiptayfirvöldum.

İzlanda'daki müşteriler için not:

Bu cihazın kullanımı, Ulusal Frekans Yönetimi Makamı tarafından verilen bireysel lisansa tabidir.

For the URX-P2/M2 Tuners

Owner's Record

The model and serial numbers are located at the rear or on the bottom of the unit. Record the model and serial numbers in the space provided below.

Refer to these numbers whenever you call upon your Sony dealer regarding this product.

Model No. _____

Serial No. _____

You are cautioned that any changes or modifications not expressly approved in this manual could void your authority to operate this equipment.

All interface cables used to connect peripherals must be shielded in order to comply with the limits for Part 15 of FCC Rules.

WARNING

Batteries shall not be exposed to excessive heat such as sunshine, fire or the like.

AVERTISSEMENT

N'exposez pas les batteries à une chaleur excessive, au soleil ou près d'un feu par exemple.

WARNUNG

Akkus dürfen keinesfalls übermäßiger Wärmeeinwirkung ausgesetzt werden, wie z.B. Sonneneinstrahlung, Feuer o. ä.

AVVERTENZA

Le batterie non devono essere esposte a fonti di calore eccessivo come luce solare diretta, fuoco, ecc.

ADVERTENCIA

No se deben exponer las baterías a una fuente de calor excesivo como la luz del sol, el fuego o similar.

For the customers in the U.S.A.

*If you have any questions about this product, you may call;
Sony Customer Information Service Center
1-800-222-7669 or
<http://www.sony.com/>*

Declaration of Conformity

Trade Name: SONY
Model No.: URX-P2/M2
Responsible Party: Sony Electronics Inc.
Address: 16530 Via Esprillo, San Diego, CA 92127 U.S.A.
Telephone No.: 858-942-2230

This device complies with part 15 of the FCC Rules. Operation is subject to the following two conditions: (1) this device may not cause harmful interference, and (2) this device must accept any interference received, including interference that may cause undesired operation.

This equipment has been tested and found to comply with the limits for a Class B digital device, pursuant to Part 15 of the FCC Rules. These limits are designed to provide reasonable protection against harmful interference in a residential installation. This equipment generates, uses, and can radiate radio frequency energy and, if not installed and used in accordance with the instructions, may cause harmful interference to radio communications. However, there is no guarantee that interference will not occur in a particular installation. If this equipment does cause harmful interference to radio or television reception, which can be determined by turning the equipment off and on, the user is encouraged to try to correct the interference by one or more of the following measures:

- Reorient or relocate the receiving antenna.
- Increase the separation between the equipment and receiver.
- Connect the equipment into an outlet on a circuit different from that to which the receiver is connected.
- Consult the dealer or an experienced radio/TV technician for help.

For the customers in Canada

Operation is subject to the following two conditions: (1) this device may not cause interference, and (2) this device must accept any interference, including interference that may cause undesired operation of the device.

The term "IC" before the radio certification number only signifies that Industry Canada technical specifications were met.

Pour les utilisateurs au Canada

L'utilisation doit répondre aux deux conditions suivantes : (1) ce matériel ne doit pas provoquer de brouillage et (2) il doit accepter tout brouillage, même celui qui est susceptible d'affecter son fonctionnement.

La mention « IC: » devant le numéro de certification/ homologation signifie uniquement que les spécifications techniques d'Industrie Canada sont remplies.

Für Kunden in Deutschland (URX-P2)

Entsorgungshinweis: Bitte werfen Sie nur entladene Batterien in die Sammelboxen beim Handel oder den Kommunen. Entladen sind Batterien in der Regel dann, wenn das Gerät abschaltet und signalisiert "Batterie leer" oder nach längerer Gebrauchsdauer der Batterien "nicht mehr einwandfrei funktioniert". Um sicherzugehen, kleben Sie die Batteriepole z.B. mit einem Klebestreifen ab oder geben Sie die Batterien einzeln in einen Plastikbeutel



U.K.	470 - 862 MHz
Germany	470 - 606 MHz, 614 - 862 MHz
Norway	800 - 820 MHz
Luxembourg	470 - 862 MHz
Belgium	470 - 862 MHz
Denmark	800.100 - 819.900 MHz
France	470 - 830 MHz
Italy	470 - 854 MHz
Sweden	470 - 862 MHz
Switzerland	790 - 862 MHz
Finland	790.100 - 821.900 MHz, 854 - 862 MHz
Iceland	470 - 862 MHz
Turkey	470 - 862 MHz

Notice for customers in Europe

Hereby, Sony Corporation, declares that this URX-P2/M2 is in compliance with the essential requirements and other relevant provisions of the Directive 1999/5/EC. For details, please access the following URL: <http://www.compliance.sony.de/>

This product is intended to be used in the following countries : United Kingdom, Germany, Norway, Luxembourg, Belgium, Denmark, France, Italy, Sweden, Switzerland, Finland, Iceland, and Turkey.

Notification aux clients européens

Par la présente Sony Corporation déclare que l'appareil URX-P2/M2 est conforme aux exigences essentielles et aux autres dispositions pertinentes de la directive 1999/5/CE.

Pour toute information complémentaire, veuillez consulter l'URL suivante: <http://www.compliance.sony.de/>

Ce produit est prévu pour être utilisé dans les pays suivants: Royaume-Uni, Allemagne, Norvège, Luxembourg, Belgique, Danemark, France, Italie, Suède, Suisse, Finlande, Islande et Turquie.

Hinweis für die Kunden in Europa

Hiermit erklärt Sony Corporation, dass sich das Gerät URX-P2/M2 in

Übereinstimmung mit den grundlegenden Anforderungen und den übrigen einschlägigen Bestimmungen der Richtlinie 1999/5/EG befindet.

Weitere Informationen erhältlich unter:
<http://www.compliance.sony.de/>

Dieses Produkt ist für den Gebrauch in den folgenden Ländern vorgesehen: Vereinigtes Königreich, Deutschland, Norwegen, Luxemburg, Belgien, Dänemark, Frankreich, Italien, Schweden, Schweiz, Finnland, Island und Türkei.

Avvertenza per gli utilizzatori in Europa

Con la presente Sony Corporation dichiara che questo URX-P2/M2 è conforme ai requisiti essenziali ed alle altre disposizioni pertinenti stabilite dalla direttiva 1999/5/CE.

Per ulteriori dettagli, si prega di consultare il seguente URL:
<http://www.compliance.sony.de/>

Questo prodotto è destinato all'uso nei seguenti paesi: Regno Unito, Germania, Norvegia, Lussemburgo, Belgio, Danimarca, Francia, Italia, Svezia, Svizzera, Finlandia, Islanda e Turchia.

Aviso para los clientes de Europa

Por medio de la presente Sony Corporation declara que el URX-P2/M2 cumple con los requisitos esenciales y cualesquiera otras disposiciones aplicables o exigibles de la Directiva 1999/5/CE.

Para mayor información, por favor consulte el siguiente URL:
<http://www.compliance.sony.de/>

Este producto está destinado a utilizarse en los siguientes países: Reino Unido, Alemania, Noruega, Luxemburgo, Bélgica,

Dinamarca, Francia, Italia, Suecia, Suiza, Finlandia, Islandia y Turquía.

Voor de klanten in Europa

Hierbij verklaart Sony Corporation dat het toestel URX-P2/M2 in overeenstemming is met de essentiële eisen en de andere relevante bepalingen van richtlijn 1999/5/EG.

Nadere informatie kunt u vinden op:
<http://www.compliance.sony.de/>

Dit product is bedoeld om in volgende landen gebruikt te worden: Verenigd Koninkrijk, Duitsland, Noorwegen, Luxemburg, België, Denemarken, Frankrijk, Italië, Zweden, Zwitserland, Finland, IJsland en Turkije.

For kunder i Europa

Härmed intygar Sony Corporation att denna URX-P2/M2 står i överensstämmelse med de väsentliga egenskapskrav och övriga relevanta bestämmelser som framgår av direktiv 1999/5/EG.

För ytterligare information gå in på följande hemsida: <http://www.compliance.sony.de/>

Den här produkten är avsedd för användning i följande länder: Storbritannien, Tyskland, Norge, Luxemburg, Belgien, Danmark, Frankrike, Italien, Sverige, Schweiz, Finland, Island och Turkiet.

Para os clientes da Europa

Sony Corporation declara que este URX-P2/M2 está conforme com os requisitos essenciais e outras disposições da Directiva 1999/5/CE.

Para mais informacoes, por favor consulte a seguinte URL:
<http://www.compliance.sony.de/>

Este produto destina-se a ser usado nos seguintes países: Reino Unido, Alemanha, Noruega, Luxemburgo, Bélgica, Dinamarca, França, Itália, Suécia, Suíça, Finlândia, Islândia e Turquia.

For kunder i Europa

Undertegnede Sony Corporation erklærer herved, at følgende udstyr URX-P2/M2 overholder de væsentlige krav og øvrige relevante krav i direktiv 1999/5/EF.

For yderligere information gå ind på følgende hjemmeside:

<http://www.compliance.sony.de/>

Dette produkt er beregnet til brug i de følgende lande: Storbritannien, Tyskland, Norge, Luxembourg, Belgien, Danmark, Frankrig, Italien, Sverige, Schweiz, Finland, Island og Tyrkiet.

Euroopassa oleville asiakkaille

Sony Corporation vakuuttaa täten että URX-P2/M2 tyyppinen laite on direktiivin 1999/5/EY oleellisten vaatimusten ja sitä koskevien direktiivin muiden ehtojen mukainen.

Halutessasi lisätietoja, käy osoitteessa:

<http://www.compliance.sony.de/>

Tämä tuote on tarkoitettu käytettäväksi seuraavissa maissa: Yhdystynyt kuningaskunta, Saksa, Norja, Luxemburg, Belgia, Tanska, Ranska, Italia, Ruotsi, Sveitsi, Suomi, Islanti ja Turkki.

For kundene i Europa

Sony Corporation erklærer herved at udstyret URX-P2/M2 er i samsvar med de grundlæggende krav og øvrige relevante krav i direktiv 1999/5/EF.

For flere detaljer, vennligst se:

<http://www.compliance.sony.de/>

Dette produktet er ment for bruk i følgende land: Storbritannia, Tyskland, Norge, Luxemburg, Belgia, Danmark, Frankrike, Italia, Sverige, Sveits, Finland, Island og Tyrkia.

Για τους πελάτες στην Ευρώπη

Με την παρούσα η Sony Corporation δηλώνει ότι UTX-B2/H2/P1 συμμορφώνεται προς της ουσιώδεις απαιτήσεις και τις λοιπές σχετικές διατάξεις της οδηγίας 1999/5/ΕΚ..

Για λεπτομέρειες παρακαλούμε όπως ελένξετε την ακόλουθη σελίδα του διαδικτύου:

<http://www.compliance.sony.de/>

Το προϊόν προορίζεται για χρήση στις εξής χώρες: Ηνωμένο Βασίλειο, Γερμανία, Νορβηγία, Λουξεμβούργο, Βέλγιο, Δανία, Γαλλία, Ιταλία, Σουηδία, Ελβετία, Φινλανδία, Ισλανδία και Τουρκία.

За клиентите в Европа

С настоящето Сони Корпорация декларира, че този URX-P2/M2 отговаря на основните изисквания и другите съответстващи клаузи на Директива 1999/5/ЕС.

Подробности може да намерите на Интернет страницата :

<http://www.compliance.sony.de/>.

Този продукт е предназначен за употреба в следните държави: Обединеното кралство, Германия, Норвегия, Люксембург, Белгия, Дания, Франция, Италия, Швеция, Швейцария, Финландия, Исландия и Турция.

Pro zákazníky v Evropě

Sony Corporation tímto prohlašuje, že tento URX-P2/M2 je ve shodě se základními požadavky a dalšími příslušnými ustanoveními směrnice 1999/5/ES.

Podrobnosti lze získat na následující URL:

<http://www.compliance.sony.de/>

Tento produkt je určen k použití v následujících zemích: Spojené království, Německo, Norsko, Lucembursko, Belgie, Dánsko, Francie, Itálie, Švédsko, Švýcarsko, Finsko, Island a Turecko.

Euroopa klientidele

Sony Corporation kinnitab käesolevaga seadme URX-P2/M2 vastavust 1999/5/EÜ direktiivi põhinõuetele ja nimetatud

direktiivist tulenevatele teistele
asjakohastele sätetele.
Üksikasjalikum info:
<http://www.compliance.sony.de/>.

See toode on ettenähtud kasutamiseks
järgmistes riikides: Suurbritannia,
Saksamaa, Norra, Luksemburg, Belgia,
Taani, Prantsusmaa, Itaalia, Rootsi, Šveits,
Soome, Island ja Türgi.

Európai vásárlóink fi gyelmébe

Alulírott, Sony Corporation
nyilatkozom, hogy a(z) URX-P2/M2
megfelel a vonatkozó alapvető
követelményeknek és az 1999/5/EC
irányelv egyéb előírásainak.
További információkat a következő
weboldalon találhat:
<http://www.compliance.sony.de/>

Ez a termék a következő országokban
használható: Egyesült Királyság,
Németország, Norvégia, Luxemburg,
Belgium, Dánia, Franciaország,
Olaszország, Svédország, Svájc,
Finnország, Izland és Törökország.

Klientiem Eiropā

Ar šo Sony Corporation deklarē, ka
URX-P2/M2 atbilst Direktīvas 1999/5/
EK būtiskajām prasībām un citiem ar to
saistītajiem noteikumiem.
Plašāka informācija ir pieejama:
<http://www.compliance.sony.de/>

Šis produkts ir paredzēts lietošanai šādās
valstīs: Apvienotā Karaliste, Vācija,
Norvēģija, Luksemburga, Beļģija, Dānija,
francija, Itālija, Zviedrija, Šveice, Somija,
Īslande un Turcija.

Klientams Europoje

Šiuo Sony Corporation deklaruoją,
kad šis URX-P2/M2 atitinka esminius
reikalavimus ir kitas 1999/5/EB Direktyvos
nuostatas.
Susipažinti su visu atitikties deklaracijos
turiniu Jūs galite interneto tinklalapyje:
<http://www.compliance.sony.de/>

Šis gaminys skirtas naudoti šiose šalyse:
Jungtinėje Karalystėje, Vokietijoje,
Norvegijoje, Liuksemburge, Belgijoje,
Danijoje, Prancūzijoje, Italijoje, Švedijoje,
Šveicarijoje, Suomijoje, Islandijoje ir
Turkijoje.

Dotyczy klientów z Europy

Niniejszym Sony Corporation
oświadcza, że URX-P2/M2 jest zgodne z
zasadniczymi wymaganiami oraz innymi
stosownymi postanowieniami
Dyrektywy 1999/5/WE.
Szczegółowe informacje znaleźć można
pod następującym adresem URL:
<http://www.compliance.sony.de/>

Ten produkt jest przeznaczony do
użytku w następujących krajach:
Wielkiej Brytanii, Niemczech, Norwegii,
Luksemburgu, Belgii, Danii, Francji,
Włoszech, Szwecji, Szwajcarii, Finlandii,
Islandii i Turcji.

Pentru clienții din Europa

Prin prezenta, Sony Corporation declară
că acest URX-P2/M2 respectă cerințele
esențiale și este în conformitate cu
prevederile Directivei 1995/5/EC.
Pentru detalii, vă rugăm accesați
următoarea adresă:
<http://www.compliance.sony.de/>

Acest produs este destinat utilizării în
următoarele țări: Regatul Unit,
Germania, Norvegia, Luxemburg,
Belgia, Danemarca, Franța, Italia,
Suedia, Elveția, Finlanda, Islanda și
Turcia.

Pre zákazníkov v Európe

Sony Corporation týmto vyhlasuje, že URX-P2/M2 spĺňa základné požiadavky a všetky príslušné ustanovenia Smernice 1999/5/ES.

Podrobnosti získate na nasledovnej webovej adrese:

<http://www.compliance.sony.de/>

Tento produkt je určený na používanie v nasledovných krajinách: Veľká Británia, Nemecko, Nórsko, Luxembursko, Belgicko, Dánsko, Francúzsko, Taliansko, Švédsko, Švajčiarsko, Fínsko, Island a Turecko.

Za stranke v Evropi

Sony Corporation izjavlja, da je ta URX-P2/M2 v skladu z bistvenimi zahtevami in ostalimi relevantnimi določili direktive 1999/5/ES.

Za podrobnosti vas naprošamo, če pogledate na URL:

<http://www.compliance.sony.de/>

Izdelek je namenjen za uporabo v naslednjih državah: Veliki Britaniji, Nemčiji, Norveški, Luksemburgu, Belgiji, Danski, Franciji, Italiji, Švedski, Švici, Finski, Islandiji in Turčiji.

WARNING

Excessive sound pressure from earphones and headphones can cause hearing loss. In order to use this product safely, avoid prolonged listening at excessive sound pressure levels.

AVERTISSEMENT

Une pression acoustique excessive en provenance des écouteurs ou du casque peut provoquer une baisse de l'acuité auditive. Pour utiliser ce produit en toute sécurité, évitez l'écoute prolongée à des pressions sonores excessives.

WARNING

Zu hoher Schalldruck von Ohrhörern und Kopfhörern kann Gehörschäden verursachen.

Um dieses Produkt sicher zu verwenden, vermeiden Sie längeres Hören bei sehr hohen Schalldruckpegeln.

AVVERTENZA

Un'eccessiva pressione sonora da auricolari e cuffie può causare la perdita dell'udito.

Per usare questo prodotto in maniera sicura, evitare l'ascolto prolungato a livelli eccessivi di pressione sonora.

ADVERTENSIA

Una excesiva presión de sonido de los auriculares y cascos auriculares puede provocar una pérdida de percepción de sus oídos.

Para utilizar este producto con seguridad, no escuche durante mucho tiempo con niveles de presión de sonido excesivos.

Table of Contents

Configuration of the Packages ...	27	(UTX-H2)	46
UWP-V1	27	Inserting the plug-on transmitter	
UWP-V2	28	(UTX-P1) into the supplied soft	
UWP-V6	29	case	46
UWP-X7	30	Attaching the optional accessory	
UWP-X8	31	to the plug-on transmitter (UTX-	
Features	32	P1)	46
UWP-V1	32	Attaching the supplied	
UWP-V2	32	accessories to the portable	
UWP-V6	32	diversity tuner (URX-P2)	47
UWP-X7	33	Installing a diversity tuner module	
UWP-X8	33	(URX-M2)	48
Using the CD-ROM Manual (U30/ U42/CE62/CE67 Models only)	34	Operation	49
Preparations	34	Tuner Settings	50
Reading the CD-ROM		Setting the reception channel	50
manual	34	Searching the available channels	
Parts Identification	35	within the group (Clear Channel	
Body-pack transmitter		Scan)	52
(UTX-B2)	35	Selecting the channels on multiple	
Hand-held microphone (UTX-		tuners automatically	53
H2)	36	Setting the monitor level	53
Plug-on transmitter (UTX-		Resetting the accumulated use	
P1)	38	time indication	54
Portable diversity tuner (URX-		Transmitter Settings	54
P2)	39	Setting the transmission	
Diversity tuner module (URX-		channel	54
M2)	41	Setting the RF output power	
Power Supply	42	level	55
Inserting the batteries	42	Setting the attenuation level of the	
Attachment and Installation		audio input	56
Procedures	44	Resetting the accumulated use	
Attaching the supplied		time indication	56
accessories to the body-pack		System Configurations.....	58
transmitter (UTX-B2)	44	Configuration examples of the	
Attaching the supplied accessory		UWP-V1/V2/X7/X8	58
to the hand-held microphone		Configuration example of the	
		UWP-V6	61

Error Messages	62
Troubleshooting	63
Important Notes on Use	66
On usage and storage	66
On cleaning	66
Specifications	67
Transmitters (UTX-B2/H2/ P1)	67
Tuners (URX-P2/M2)	69

Configuration of the Packages

This manual is for the UWP-V1/V2/V6/X7/X8 Wireless Microphone Packages. The contents of each package are described below.

Note

Some of the packages may not be available in certain countries or areas. For details, consult your Sony dealer.

UWP-V1

The UWP-V1 consists of a body-pack transmitter (UTX-B2), a portable diversity tuner (URX-P2), and their accessories. When used in conjunction with a compact camcorder, the UWP-V1 makes a mobile system for ENG (Electronic News Gathering) or EFP (Electronic Field Production) purposes.

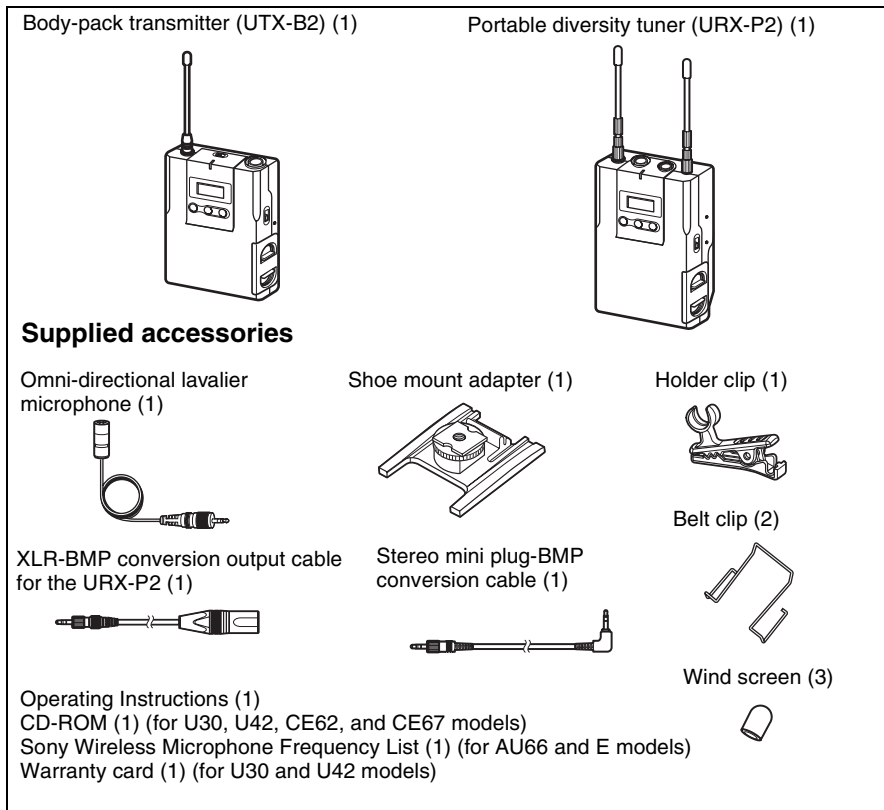

UWP-V2

The UWP-V2 consists of a hand-held microphone (UTX-H2), a portable diversity tuner (URX-P2), and their accessories. When used in conjunction with a compact camcorder, the UWP-V2 makes a mobile system for ENG (Electronic News Gathering) or EFP (Electronic Field Production) purposes.

Hand-held microphone (UTX-H2) (1)



Portable diversity tuner (URX-P2) (1)

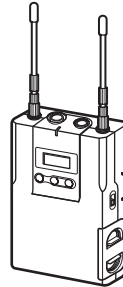

Supplied accessories

Microphone holder (1)



Belt clip (1)

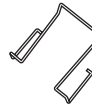

Shoe mount adapter (1)

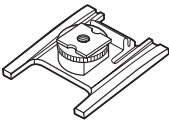

XLR-BMP conversion output cable for the URX-P2 (1)

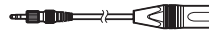

Stereo mini plug-BMP conversion cable (1)

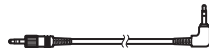

Operating Instructions (1)

CD-ROM (1) (for U30, U42, CE62, and CE67 models)

Sony Wireless Microphone Frequency List (1) (for AU66 and E models)

Warranty card (1) (for U30 and U42 models)

UWP-V6

The UWP-V6 consists of a plug-on transmitter (UTX-P1), a body-pack transmitter (UTX-B2), a portable diversity tuner (URX-P2), and their accessories. When used in conjunction with a compact camcorder, the UWP-V6 makes a mobile system for ENG (Electronic News Gathering) or EFP (Electronic Field Production) purposes.

Plug-on transmitter (UTX-P1) (1)

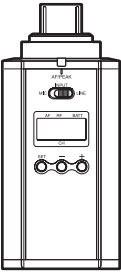

Body-pack transmitter (UTX-B2) (1)



Portable diversity tuner (URX-P2) (1)

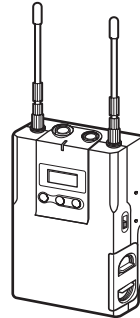

Supplied accessories

Omni-directional lavalier microphone (1)

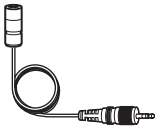

Wind screen (3)



Holder clip (1)



Soft case (1)

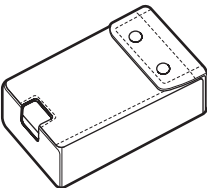

Shoe mount adapter (1)

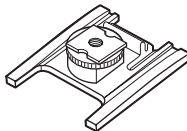

Belt clip (2)

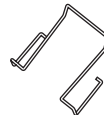

Stereo mini plug-BMP conversion cable (1)

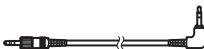

XLR-BMP conversion output cable for the URX-P2 (1)



Operating Instructions (1)
CD-ROM (1) (for U30, U42, CE62, and CE67 models)
Warranty card (1) (for U30 and U42 models)

UWP-X7

The UWP-X7 consists of a body-pack transmitter (UTX-B2), a diversity tuner module (URX-M2), and their accessories. By installing the tuner module into the tuner base unit or the powered mixer, the system construction to meet the desired purpose of use and required system scale becomes possible.

Body-pack transmitter (UTX-B2) (1)



Diversity tuner module (URX-M2) (1)

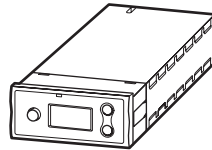

Supplied accessories

Unidirectional lavalier microphone (1)



Wind screen (1)



Holder clip (1)



Belt clip (1)

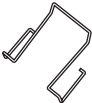

Operating Instructions (1)

CD-ROM (1) (for U30, U42, CE62, and CE67 models)

Sony Wireless Microphone Frequency List (1) (for AU66 and E models)

Warranty card (1) (for U30 and U42 models)

UWP-X8

The UWP-X8 consists of a hand-held microphone (UTX-H2), a diversity tuner module (URX-M2), and their accessories. By installing the tuner module into the tuner base unit or the powered mixer, the system construction to meet the desired purpose of use and required system scale becomes possible.

Hand-held microphone (UTX-H2) (1)



Diversity tuner module (URX-M2) (1)

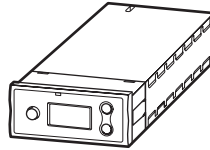

Supplied accessories

Microphone holder (1)

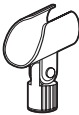

Operating Instructions (1)
CD-ROM (1) (for U30, U42, CE62, and CE67 models)
Sony Wireless Microphone Frequency List (1) (for AU66 and E models)
Warranty card (1) (for U30 and U42 models)

Features

Each of the UWP-V1/V2/V6/X7/X8 wireless microphone packages (referred to as the UWP series packages hereafter) combines a transmitter (body-pack transmitter (UTX-B2) or hand-held microphone (UTX-H2)) and a receiver (portable diversity tuner (URX-P2) or diversity tuner module (URX-M2)). (An additional transmitter (plug-on transmitter (UTX-P1) is provided for the UWP-V6 only.) The UWP series packages can be used with a compact camcorder for ENG (Electronic News Gathering) purposes, and with a powered mixer for AV presentations or as a PA (public address) system.

Note

The UWP series packages are not compatible with the WRT series transmitters, WRR series tuners, or WRU series tuner units.

The featured components of the package are described below.

UWP-V1

Body-pack transmitter (UTX-B2)

This is a small and lightweight transmitter with a crystal-controlled PLL (phase lock loop) synthesized system and a BMP-type microphone input connector. The RF power output can be switched between 30 mW and 5 mW (for U30, U42, CE62, CE67, and AU66 models) or 10 mW and 2 mW (for E model). The MIC/LINE input selector is equipped to accept wide range of input signals.

Portable diversity tuner (URX-P2)

This tuner employs a space diversity system with little signal dropout and two angle-adjustable antennas. It comes with an adapter for mounting the tuner on the compact camcorder (PMW-EX1, HDR-Z7, etc.). The Clear Channel Scan function is also provided to search available channels with easy operation.

UWP-V2

Hand-held microphone (UTX-H2)

This microphone is equipped with a built-in antenna and a unidirectional dynamic microphone unit. The RF power output can be switched between 30 mW and 5 mW (for U30, U42, CE62, CE67, and AU66 models) or 10 mW and 2 mW (for E model).

Portable diversity tuner (URX-P2)

This tuner employs a space diversity system with little signal dropout and two angle-adjustable antennas. It comes with an adapter for mounting the tuner on the compact camcorder (PMW-EX1, HDR-Z7, etc.). The Clear Channel Scan function is also provided to search available channels with easy operation.

UWP-V6

Plug-on transmitter (UTX-P1)

This is a small and lightweight plug-on transmitter with a crystal-controlled PLL (phase lock loop) synthesized system and an XLR-type microphone input connector. The RF power output is set at 50 mW.

Body-pack transmitter (UTX-B2)

This is a small and lightweight transmitter with a crystal-controlled PLL (phase lock loop) synthesized system and a BMP-type microphone input connector. The RF power output can be switched between 30 mW and 5 mW (for U30, U42, CE62, CE67, and AU66 models) or 10 mW and 2 mW (for E model). The MIC/LINE input selector is equipped to accept wide range of input signals.

Portable diversity tuner (URX-P2)

This tuner employs a space diversity system with little signal dropout and two angle-adjustable antennas. It comes with an adapter for mounting the tuner on the compact camcorder (PMW-EX1, HDR-Z7, etc.). The Clear Channel Scan function is also provided to search available channels with easy operation.

UWP-X7

Body-pack transmitter (UTX-B2)

This is a small and lightweight transmitter with a crystal-controlled PLL (phase lock loop) synthesized system and a BMP-type microphone input connector. The RF power output can be switched between 30 mW and 5 mW (for U30, U42, CE62, CE67, and AU66 models) or 10 mW and 2 mW (for E model). The MIC/LINE input selector is equipped to accept wide range of input signals.

Diversity tuner module (URX-M2)

This tuner module can be incorporated into the MB-X6 Tuner Base Unit or SRP-X500P Powered Mixer.

UWP-X8

Hand-held microphone (UTX-H2)

This microphone is equipped with a built-in antenna and a unidirectional dynamic microphone unit. The RF power output can be switched between 30 mW and 5 mW (for U30, U42, CE62, CE67, and AU66 models) or 10 mW and 2 mW (for E model).

Diversity tuner module (URX-M2)

This tuner module can be incorporated into the MB-X6 Tuner Base Unit or SRP-X500P Powered Mixer.

Using the CD-ROM Manual (U30/U42/CE62/CE67 Models only)

The supplied CD-ROM includes the Operating Instructions for the UWP series packages (English, French, German, Italian, and Spanish versions) and the frequency lists in PDF format.

Preparations

The following program must be installed on your computer in order to read the Operating Instructions contained on the CD-ROM.

- Adobe Reader Version 6.0 or higher

Memo

If Adobe Reader is not installed, you can download it from the following URL:
<http://www.adobe.com/>

Adobe and Adobe Reader are trademarks of Adobe Systems Incorporated in the United States and/or other countries.

Reading the CD-ROM manual

To read the Operating Instructions and frequency lists contained on the CD-ROM, do the following.

- 1** Insert the CD-ROM in your CD-ROM drive.

A cover page appears automatically in your browser.

If it does not appear automatically in the browser, double-click on the index.htm file on the CD-ROM.

- 2** Select and click on the Operating Instructions or the frequency lists that you want to read.

This opens the selected PDF file.

Memo

The files may not be displayed properly, depending on the version of Adobe Reader. In such a case, install the latest version you can download from the URL mentioned in “Preparations” above.

Note

If you have lost or damaged the CD-ROM, you can purchase a new one to replace it.

Parts Identification

Body-pack transmitter (UTX-B2)

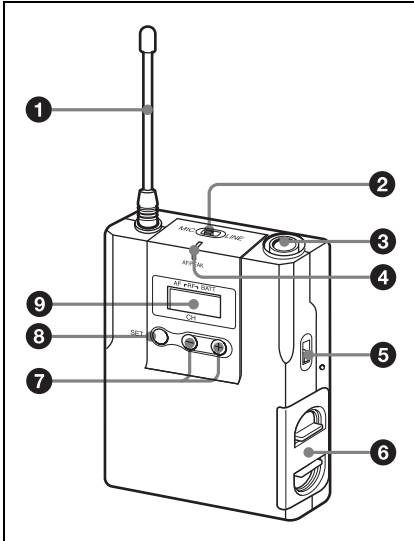

1 Antenna

2 MIC/LINE (microphone/line) input selector

Set according to the equipment connected to the audio input connector.

Note

Do not set the MIC/LINE input selector to MIC position while the audio signal is being input from the audio mixer, etc.

Doing so may cause excessive audio input, resulting in distorted playback or recorded sound or damage to the playback or recording equipment.

3 Audio input connector

Connect the supplied lavalier microphone here. By using a commercially available XLR-BMP conversion input cable, UTX-B2, the line output connector of the audio mixer or the microphone which does not require the external power supply can also be connected.

Notes

- When the MIC/LINE input selector is set to MIC position, a power voltage for the supplied lavalier microphone is applied to the audio input connector. For this purpose, a special electrical wiring is used inside this connector. Be sure to use a commercially available XLR-BMP conversion input cable to connect the equipment other than the supplied lavalier microphone.
- Note that the proper performance may not be obtained if a lavalier microphone which is not supplied with the UWP series package is used.

4 AF/PEAK (audio frequency/peak level) indicator

Turns on or off according to the audio input level as follows.

On (red): Audio input level is too high. If the sound is distorted, increase the attenuation level of the audio input (*see page 56*).

On (green): Audio input level is appropriate.

Off: There is no audio input or input level is too low.

5 POWER switch

Turns the power of the transmitter ON or OFF.

6 Battery compartment

Accommodates two LR6 (size AA) alkaline batteries.

For details on how to insert the batteries, see “Power Supply” on page 42.

7 + (+ selection) / - (- selection/reset) buttons

Press these buttons to set the transmission channel, frequency, or attenuation level of the input signal.

The “-” button resets the accumulated use time to “00:00”.

8 SET button

Press to change and enter display parameters.

For details, see “Transmitter Settings” on page 54.

9 Display section

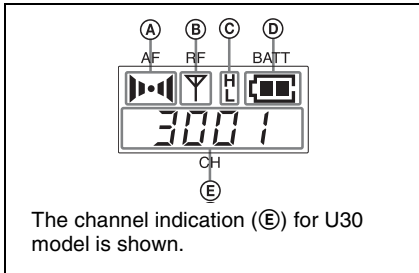

(A) AF (audio frequency) indication

Appears whenever the input audio signal is stronger than the reference level.

(B) RF (radio frequency) indication

Appears during signal transmission from the antenna.

(C) RF (radio frequency) level indication

Shows the RF output level setting.

For details, see “Setting the RF output power level” on page 55.

(D) BATT (battery) indication

Shows the battery condition.

For details, see “Battery indication” on page 43.

(E) CH (channel) indication

Shows the transmission channel. Each time you press the SET button in transmission mode, the channel indication changes as follows.

For details, see “Transmitter Settings” on page 54.

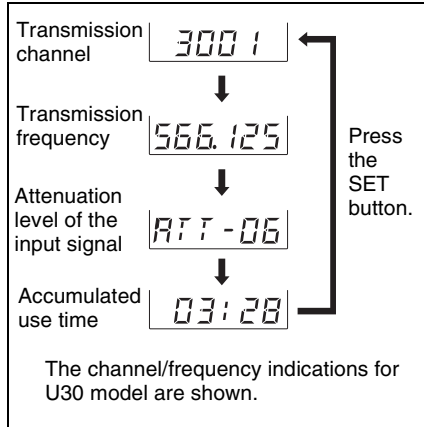

Hand-held microphone (UTX-H2)

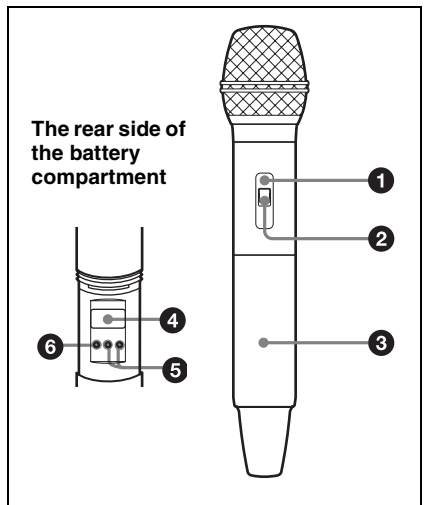

1 Power indicator

Lights up green when the microphone is turned on.

2 POWER switch

Turns the power of the microphone ON or OFF.

3 Battery compartment

Accommodates two LR6 (size AA) alkaline batteries.

For details on how to insert the batteries, see "Power Supply" on page 42.

4 Display section

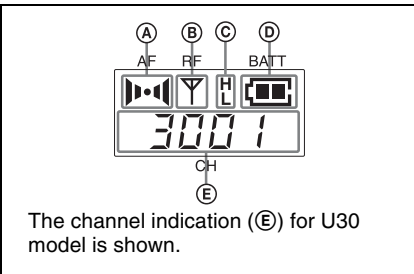

The channel indication (E) for U30 model is shown.

A AF (audio frequency) indication

Appears whenever the input audio signal is stronger than the reference level.

B RF (radio frequency) indication

Appears during signal transmission from the antenna.

C RF (radio frequency) level indication

Shows the RF output level setting.

For details, see "Setting the RF output power level" on page 55.

D BATT (battery) indication

Shows the battery condition.

For details, see "Battery indication" on page 43.

E CH (channel) indication

Shows the transmission channel. Each time you press the SET button in transmission

mode, the channel indication changes as follows.

For details, see "Transmitter Settings" on page 54.

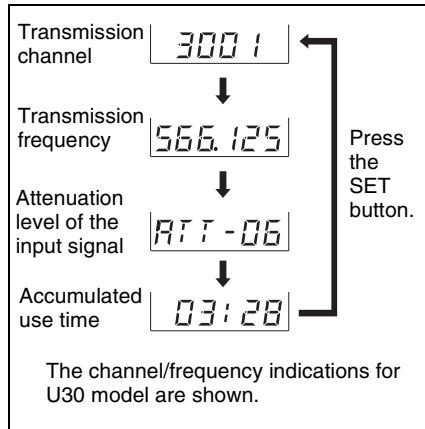

The channel/frequency indications for U30 model are shown.

5 + (+ selection) / - (- selection/reset) buttons

Press these buttons to set the transmission channel, frequency, or attenuation level of the input signal.

The "-" button resets the accumulated use time to "00:00".

6 SET button

Press to change and enter display parameters.

For details, see "Transmitter Settings" on page 54.

Plug-on transmitter (UTX-P1)

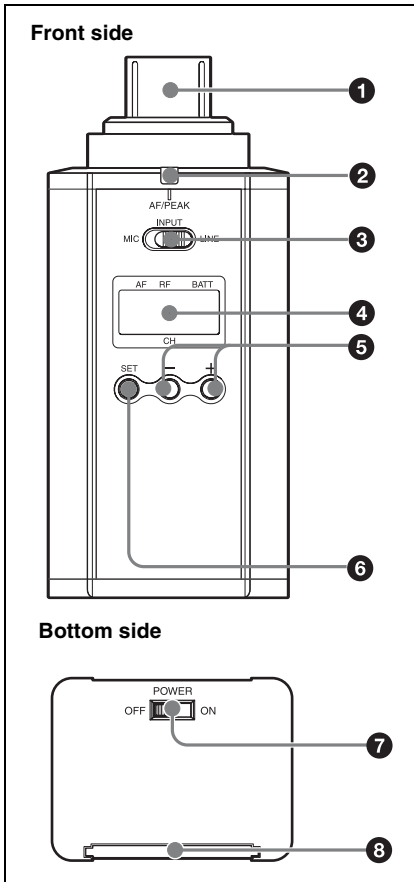

1 Audio input connector (XLR type)

Connect a microphone or a line output connector of an audio mixer, etc.

2 AF/PEAK (audio frequency/peak level) indicator

Turns on or off according to the audio input level as follows.

Audio input level	INPUT selector position	
	MIC	LINE
+8 dBV or more	—	On (red)
-9 dBV or more and less than +8 dBV	—	On (green)
Less than -9 dBV	—	Off
-40 dBV or more	On (red)	—
-60 dBV or more and less than -40 dBV	On (green)	—
Less than -60 dBV	Off	—

3 INPUT (input signal) selector

Set this selector to MIC when a microphone is connected to the audio input connector; set it to LINE when an audio mixer, etc. is connected to the audio input connector.

Notes

- The UTX-P1 does not support external power supply. Do not connect a microphone which requires external power supply.
- Do not set the INPUT selector to MIC position while the audio signal is being input from the audio mixer, etc. Doing so may cause excessive audio input, resulting in distorted playback or recorded sound or damage to the playback or recording equipment.

4 Display section

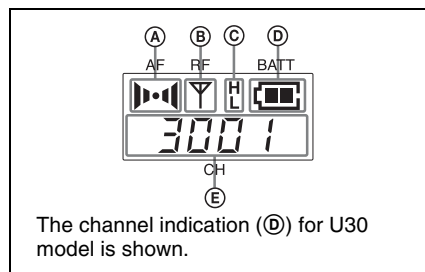

Ⓐ AF (audio frequency) indication

Appears whenever the input audio signal is stronger than the reference level.

Ⓑ RF (radio frequency) indication

Appears during signal transmission from the antenna.

Ⓒ BATT (battery) indication

Shows the battery condition.

For details, see "Battery indication" on page 43.

Ⓓ CH (channel) indication

Shows the transmission channel. Each time you press the SET button in transmission mode, the channel indication changes as follows.

For details, see "Transmitter Settings" on page 54.

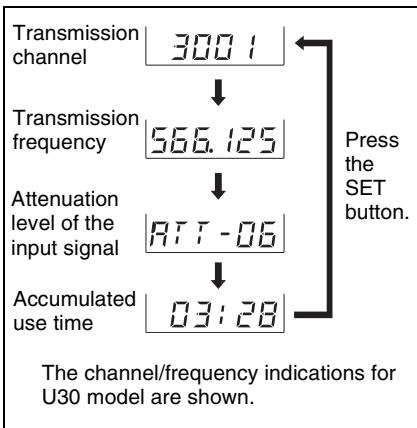

Ⓟ + (+ selection) / - (- selection/reset) buttons

Press these buttons to set the transmission channel, frequency, or attenuation level of the input signal.

The "-" button resets the accumulated use time to "00:00".

Ⓠ SET button

Press to change and enter display parameters.

For details, see "Transmitter Settings" on page 54.

Ⓡ POWER switch

Turns the power of the microphone ON or OFF.

Ⓢ Battery compartment

Accommodates two LR6 (size AA) alkaline batteries.

For details on how to insert the batteries, see "Power Supply" on page 42.

Portable diversity tuner (URX-P2)

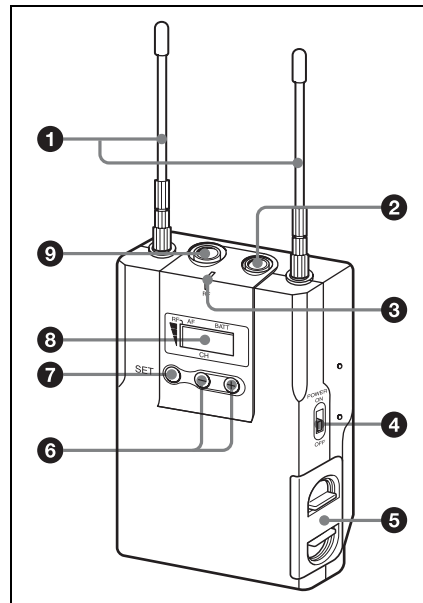

Ⓛ 1 Antennas

Ⓛ 2 MONITOR connector (3.5-mm diameter stereo mini jack)

To monitor the tuner output, connect the headphones to this connector.

Note

Do not connect headphones with a monaural mini jack. This may lead to short-circuiting of the headphone output, resulting in distorted sound output.

3 RF (radio frequency) indicator

The color indicates the strength of the RF input signal.

On (green): RF input is 15 dB μ ¹ or more.

Off: RF input is less than 15 dB μ ¹.

1) 0 dB μ = 1 μ V_{EMF}

4 POWER switch

Turns the power of the tuner ON or OFF.

5 Battery compartment

Accommodates two LR6 (size AA) alkaline batteries.

For details on how to insert the batteries, see "Power Supply" on page 42.

6 + (+ selection) / - (- selection/reset) buttons

Press these buttons to set the transmission channel, frequency, or attenuation level of the input signal.

The "-" button resets the accumulated use time to "00:00".

7 SET button

Press to change and enter display parameters.

For details, see "Tuner Settings" on page 50.

8 Display section

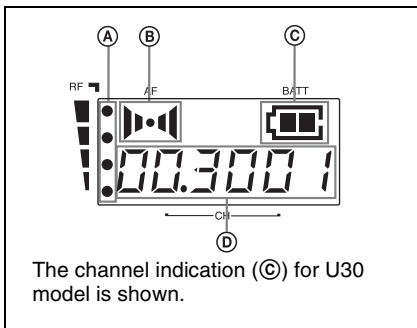

A RF (radio frequency) indications

The number of dots indicates the RF input level.

B AF (audio frequency) indication

Appears whenever the output audio signal is stronger than the reference level.

C BATT (battery) indication

Shows the battery condition.

For details, see "Battery indication" on page 43.

D CH (channel) indication

Shows the reception channel group and channel number. Each time you press the SET button, the channel indication changes as follows.

For details, see "Tuner Settings" on page 50.

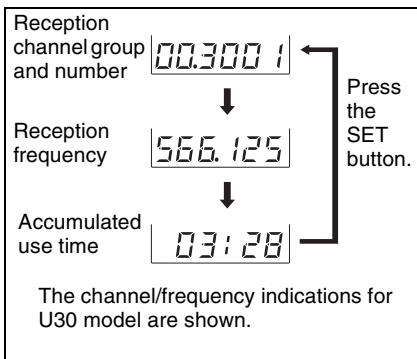

9 OUTPUT (audio output) connector (3.5-mm diameter stereo mini jack)

Connect one end of the supplied XLR-BMP conversion output cable for the URX-P2 or the stereo mini plug-BMP conversion cable here and the other end to the microphone input on a camcorder, mixer, or amplifier. If the microphone input connector on the device connected to the tuner is a stereo mini jack, connect the straight (BMP) plug to the tuner and the L-shaped (stereo mini) plug to the microphone input connector on the device.

Note

To prevent damaging the tuner, do not apply power voltage to this connector through the connection to external devices.

Diversity tuner module (URX-M2)

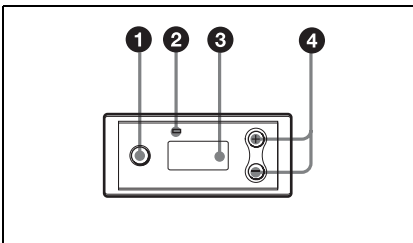

1 SET button

Press to change and enter display parameters.

For details, see “Tuner Settings” on page 50.

2 RF (radio frequency) indicator

The color indicates the strength of the RF input signal.

On (green): RF input is 25 dB μ ¹⁾ or more.
Off: RF input is less than 25 dB μ ¹⁾.

1) 0 dB μ = 1 μ VEMF

3 Display section

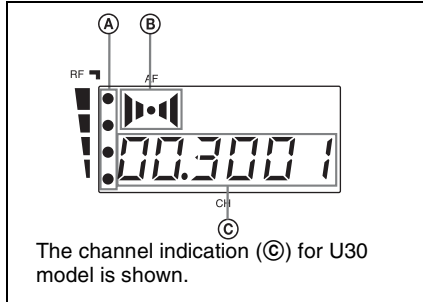

A RF (radio frequency) indications

The number of dots indicates the RF input level.

B AF (audio frequency) indication

Appears whenever the output audio signal is stronger than the reference level.

C GP (group)/CH (channel) indication

Shows the reception channel group and channel number. Each time you press the SET button, the channel indication changes as follows.

For details, see “Tuner Settings” on page 50.

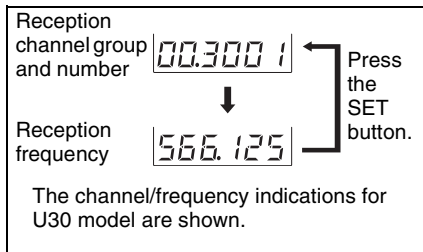

4 + (+ selection) / - (- selection/reset) buttons

Press these buttons to set the reception channel and frequency.

Power Supply

This section explains the power supply for each component.

Diversity tuner module (URX-M2)

When incorporated into another component (e.g., MB-X6, SRP-X500P, etc.), the tuner module draws its power from that component.

For details on the power supply to the diversity tuner module, refer to the operating instructions of the component in which the diversity tuner module is installed.

Body-pack transmitter (UTX-B2), hand-held microphone (UTX-H2), plug-on transmitter (UTX-P1), and portable diversity tuner (URX-P2)

These components can be powered by two LR6 (size AA) alkaline batteries. Details on inserting the batteries and the battery condition indication are given below:

Note

The manganese batteries cannot draw sufficient performance from the component. Be sure to use the alkaline batteries.

Inserting the batteries

Body-pack transmitter (UTX-B2)/portable diversity tuner (URX-P2)

The procedure below uses the body-pack transmitter (UTX-B2) in the illustrations.

Batteries can also be inserted in the portable diversity tuner (URX-P2) in the same manner.

- 1 Slide the battery-compartment catches inward (in the direction of the arrows → ◀) to take out the battery holder.

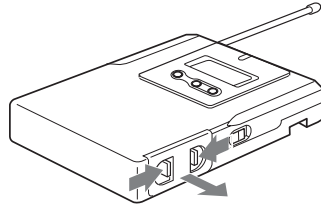

- 2 Insert the batteries into the battery compartment by matching their polarities to the indications inside the compartment. Then, set the battery holder in the original position.

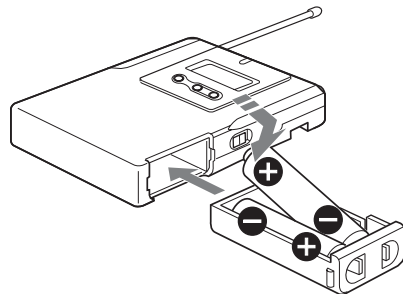

Note

Taking out the battery compartment during signal transmission may cause high noise. Be sure to turn off the component before taking out the battery compartment.

Hand-held microphone (UTX-H2)

- 1 Turn the grip in the direction of the arrow to open the battery compartment.

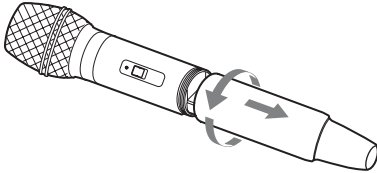

- 2 Align two new LR6 (size AA) alkaline batteries with the polarity markings and insert them into the battery compartment.

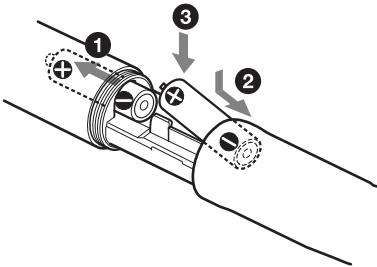

- 3 Turn the grip in the direction opposite to the arrow in step 1 to close the battery compartment.

Note

If you open the battery compartment during signal transmission, the noise may occur. Be sure to turn the microphone off before opening the battery compartment.

Plug-on transmitter (UTX-P1)

- 1 Slide the battery cover to release the lock and open the battery compartment.

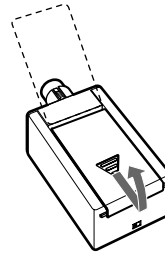

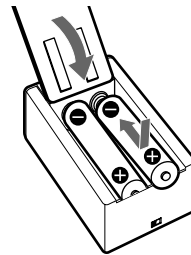

- 2 Align two new LR6 (size AA) alkaline batteries with the polarity markings and insert them into the battery compartment, and then close the cover.





Battery indication

When you turn the power on, the battery condition is shown by the BATT indication in the display section.

When the indication in column 4 starts to flash, replace the batteries with new ones. Be sure to check the expiration date printed on the new batteries before using them.

	BATT indication	Battery status
1	Lights 	Good
2	Lights 	Less than 50% charged

	BATT indication	Battery status
3	Lights 	Less than 20% charged
4	Flashes 	Almost drained

Note

The indicated battery condition may not be correct if the batteries were not new when installed. If you plan to use the component for a long period, it is recommended that you replace the batteries with brand new ones.

Notes on battery

Batteries may leak or explode if mistreated. Be sure to follow these instructions.

- Be sure to install the batteries with the correct polarity.
- Always replace the two batteries together.
- Do not use different types of batteries or old and new one together.
- The batteries are not rechargeable.
- When not using the component for a long period of time, remove the batteries to avoid leakage. If the batteries do leak, clean all leakage from the battery compartment and the component. Leakage left in the compartment and the component may cause poor battery contact. If there seems to be poor battery contact, consult your Sony dealer.

Attachment and Installation Procedures

This section describes the procedures for attaching the supplied accessories to the components and the installation of the diversity tuner module (URX-M2) into the MB-X6 Tuner Base Unit or SRP-X500P Powered Mixer.

Attaching the supplied accessories to the body-pack transmitter (UTX-B2)

To attach the microphone

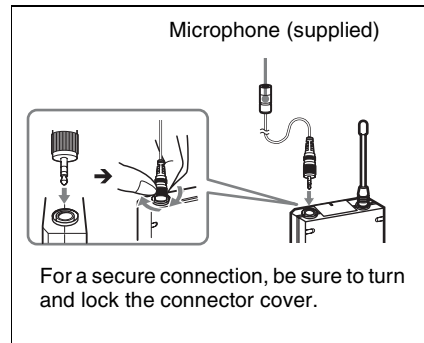

Note

Be sure to attach or remove the microphone after turning off the transmitter.

To attach the holder clip to the microphone

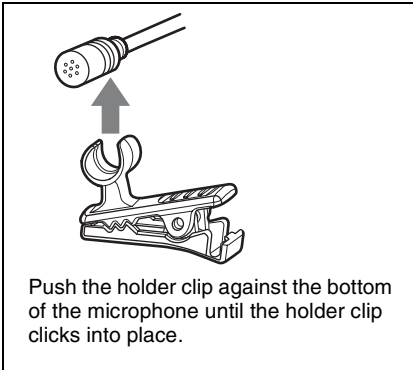

To take the slack out of the microphone cable

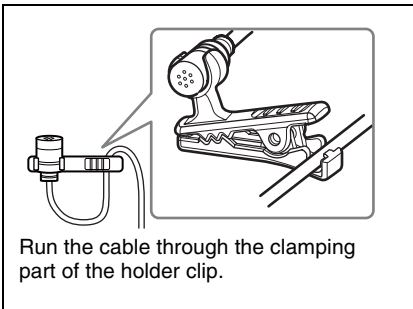

To attach the wind screen to the microphone

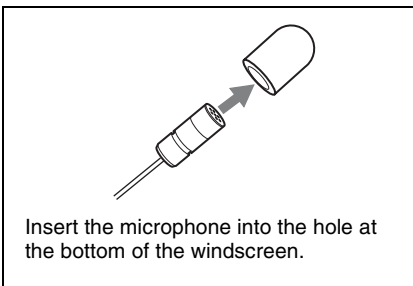

To attach the belt clip

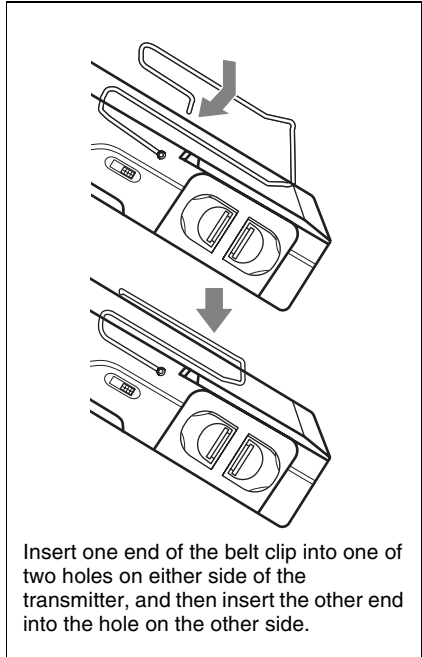

To remove the belt clip

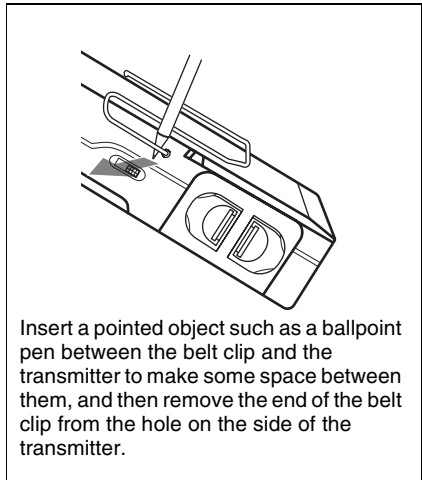

Attaching the supplied accessory to the hand-held microphone (UTX-H2)

To attach the microphone holder

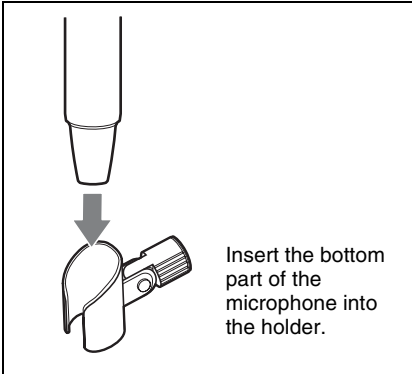

Attaching the optional accessory to the plug-on transmitter (UTX-P1)

To attach a microphone or a cable

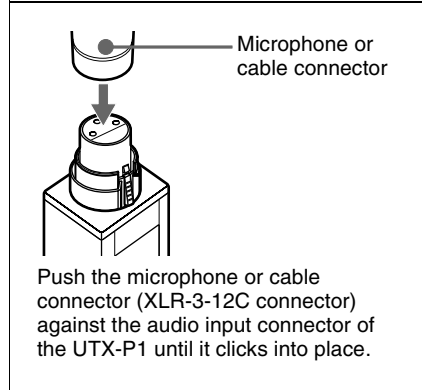

Inserting the plug-on transmitter (UTX-P1) into the supplied soft case

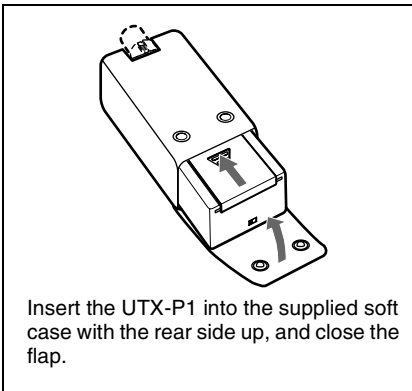

To detach a microphone or a cable

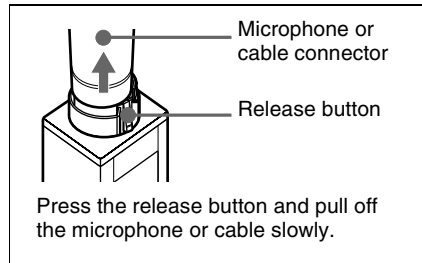

Attaching the supplied accessories to the portable diversity tuner (URX-P2)

To connect the supplied conversion cable to the OUTPUT connector

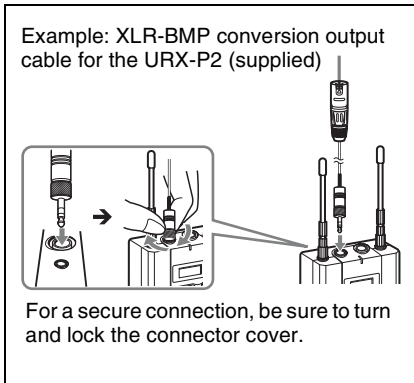

To attach the belt clip

See "To attach the belt clip" on page 45.

To attach the shoe mount adapter

Before attaching the shoe mount adapter, attach the belt clip (*see page 45*).

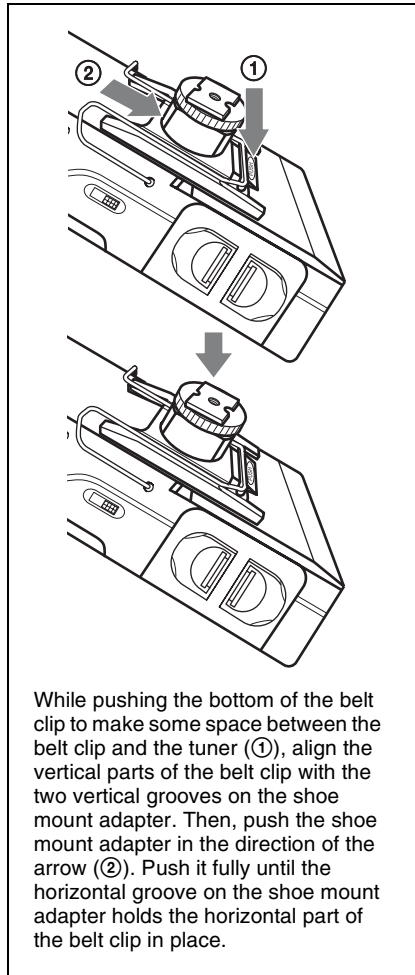

To remove the shoe mount adapter

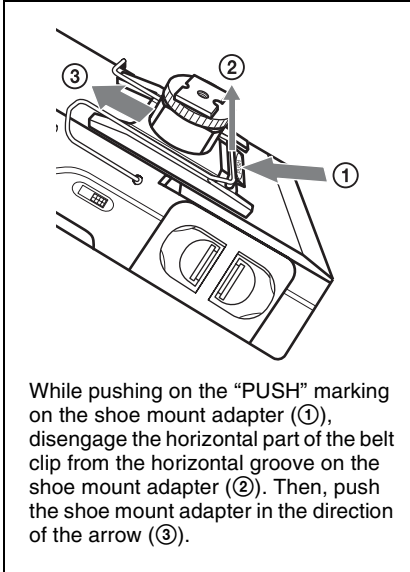

Installing a diversity tuner module (URX-M2)

Notes

- Before installing the diversity tuner module (URX-M2), make sure the unit into which the tuner module will be installed is turned off. Do not install or uninstall the tuner module while the unit into which the tuner module will be installed is turned on, as this may result in malfunction of the tuner module or cause noise.
- Do not put your fingers on the connectors on the rear panel of the tuner module or into the slot on the unit into which the tuner module will be installed.
- Keep the tuner module away from static electricity.

To install a diversity tuner module (URX-M2) into the optional MB-X6 Tuner Base Unit

The MB-X6 Tuner Base Unit (not supplied) can accommodate up to 6 diversity tuner modules (URX-M2).

For details on installation procedure, refer to the Operating Instructions supplied with the MB-X6.

Hold the tuner module by the side and insert it into the slot until you hear a click.

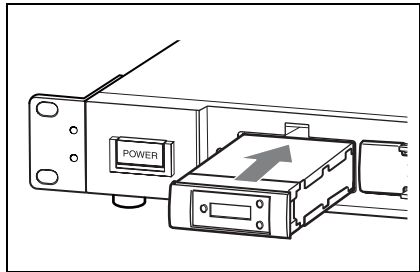

To install two or more tuner modules

Before installing the tuner modules, detach the necessary number of blank panels from the front cover of the MB-X6.

To uninstall a tuner module

After removing the front cover of the MB-X6, hold the tuner unit by the top and bottom, then pull it out of the slot.

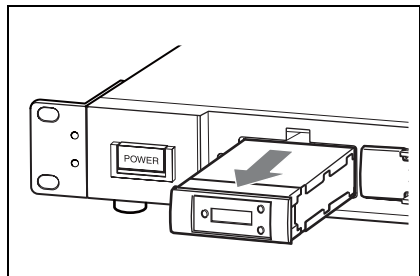

To install a diversity tuner module (URX-M2) into the optional SRP-X500P Powered Mixer

The SRP-X500P Powered Mixer (not supplied) can accommodate up to two diversity tuner modules (URX-M2).

For details on installation procedure, refer to the Operating Instructions supplied with the SRP-X500P.

Remove the protection panel (large) from the SRP-X500P. Inspect the top and bottom sides of the diversity tuner module and insert it into the slot.

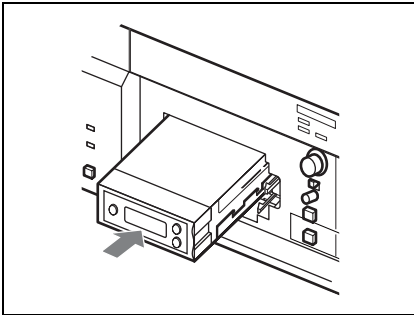

To uninstall the tuner module

Pull the latch securing the tuner module to the side and pull out the tuner module.

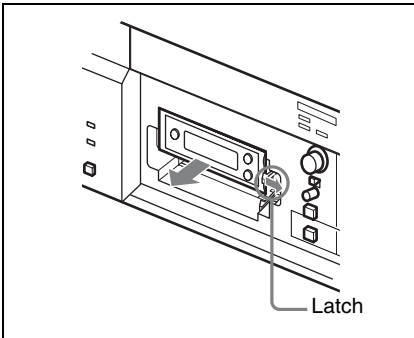

Operation

The procedure below is the same for all UWP series transmitters (UTX-B2/H2/P1) and tuners (URX-P2/M2).

- 1 Make all necessary connections on the tuner.

For examples of UWP series component connections, see "System Configurations" on page 58.

- 2 Turn on the tuner.

The parameters that were in the display section when the tuner was last turned off appear again.

Note

Noise will be produced when the tuner is turned on. Before turning on the tuner, turn down the volume of the equipment connected to the tuner.

- 3 Set the reception channel on the tuner.

Switch the channel on the tuner with the transmitter turned off and select the channel where the RF indicator does not turn on.

For details on setting the reception channel, see "Setting the reception channel" on page 50.

- 4 Set the transmission channel on the transmitter, and then turn off the unit.

For details on setting the transmission channel, see "Setting the transmission channel" on page 54.

- 5 Turn on the transmitter.

If noise is heard

Depending on the environment where the UWP series components are installed, external noise or radio waves may disrupt transmission on certain channels.

When selecting a channel under these circumstances, turn off the transmitter.

Then, on the tuner, select a channel for which the RF indicator does not light up (i.e., a channel free from noise or radio wave interference). Set the same channel on the transmitter.

Note

To prevent interference or noise, please take the following precautions.

- Do not use two or more transmitters with the same wireless channels.
- When operating two or more UWP series packages simultaneously, set each package to a different channel within the same channel group.
- Keep the reception antenna and the transmitter separated more than 3 meters (9 feet 11 inches).
- When operating two or more UWP series packages simultaneously with different channel groups, make sure that they are at least 100 meters (330 feet) apart, if they are used within clear sight of each other. (The actual distance may differ depending on the circumstances.)

Tuner Settings

Setting the reception channel

The procedure below is the same for all UWP series tuners (URX-P2/M2).

For U30/U42/CE62/CE67 models:

Refer to the pdf files “Sony Wireless Microphone System Frequency List” on the supplied CD-ROM for details on the selectable channel groups and channels.

For AU66/E models:

Refer to the supplied leaflet “Sony Wireless Microphone System Frequency List” for details on the selectable channel groups and channels.

- 1** Press down the SET button for more than one second.
Keep pressing the SET button until the display section parameters start to flash.
- 2** Press the SET button repeatedly until the channel group and the channel number indications appear.
The channel group indication starts to flash.



- 3** Press the + or – button to select the channel group.

Pressing the + button cycles the indication in the order shown in the tables in the pdf files “Sony Wireless Microphone System Frequency List”

on the supplied CD-ROM (for U30, U42, CE62, and CE67 models) or in the supplied leaflet “Sony Wireless Microphone System Frequency List” (for AU66 and E models).

Pressing the – button cycles the indications in the opposite direction. Hold down the + or – button to change the channel group faster.

- 4** When the desired channel group number appears, press the SET button.

The selected group is entered. The right four digits start to flash to allow the selection of the channel number.



- 5** Press the + or – button to select the channel number.

The channel indication changes in the order shown in the tables in the pdf files “Sony Wireless Microphone System Frequency List” on the supplied CD-ROM (for U30, U42, CE62, and CE67 models) or in the supplied leaflet “Sony Wireless Microphone System Frequency List” (for AU66 and E models).

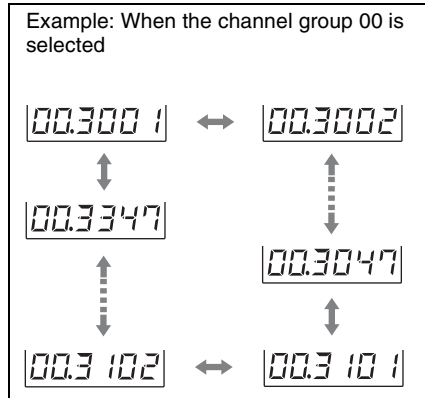

- 6** When the desired channel number appears, leave the tuner for about 10 seconds or press down the SET button for more than one second.

The selected channel number stops flashing and the selection is stored in memory.

To select the channel by frequency indication

- 1** Press the SET button for more than one second.
Keep pressing the SET button until the display section parameters start to flash.
- 2** Press the SET button repeatedly until the frequency indication appears and starts flashing.

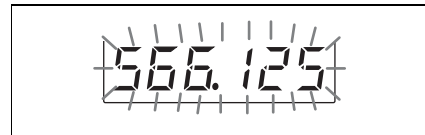

- 3** Press the + or – button to select the frequency.

- 4** When the desired frequency appears, leave the tuner for about 10 seconds or press down the SET button for more than one second.

The selected channel number stops flashing and the selection is stored in memory.

Notes

- Even when you are setting the reception channel, the tuner can be used to receive signals.
- Do not remove the batteries while setting the reception channel. If they are inadvertently removed, re-insert them immediately and redo the procedure “Setting the reception channel” from step 1.
- Make sure that the selected channel is the same on the transmitter and tuner being used in the same system.
- If you turn off the tuner and then immediately turn it on right after setting the reception channel, the unit may not operate normally. Wait a few seconds before turning it on again.

Searching the available channels within the group (Clear Channel Scan)

The procedure below can be performed with the portable diversity tuner (URX-P2) only.

Available channels within the specified channel group can be searched. Before performing this procedure, select the channel group.

For details on channel group selection, see “Setting the reception channel” on page 50.

- 1** While pressing down the SET button, press the + button.

Keep both buttons pressed down.

- 2** Release the SET button and the + button after “SCAN +” appears and starts flashing.



- 3** Press the + button.

The tuner starts to scan through the selected channel group. When available channels are found, the first channel number among the available channels flashes in the display.

To display the next available channel number

Press the + button.

To cancel searching

Press the – button. The display shows the flashing “SCAN +” again.

To re-select the channel group

Press the SET button again to display the flashing channel group indication, then select the channel group. And then, start from step 1.

- 4** While the desired channel number is flashing, leave the tuner for about 10 seconds or press down the SET button for more than one second.

Search finishes. The selected channel number stops flashing and the selection is stored in memory.

To start searching while performing settings

While the display section parameters are flashing, press the SET button repeatedly

until “SCAN +” appears and starts flashing. Then, start from step **3** above.

Selecting the channels on multiple tuners automatically

The procedure below can be performed with the diversity tuner module (URX-M2) only.

When multiple diversity tuner modules (URX-M2) are installed into the MB-X6 to perform simultaneous multiple-channel operation, select the channel group on the tuner module installed into the slot **1** of the MB-X6, then all the tuner modules installed into the MB-X6 can be set to different channels within the selected channel group.

- 1** Turn off all the microphones and transmitters.
- 2** Select the channel group on the tuner module installed into the slot **1** of the MB-X6.
- 3** After confirming that the channel group indication has stopped flashing (about 10 seconds after you have selected the channel group), keep pressing the + button on the tuner module installed into the slot **1** of the MB-X6.

All the tuner modules installed into the MB-X6 are set to the available channels within the selected channel group.

After the automatic detection and selection of available channels finish, you can change the group and channel on each tuner module manually.

Notes

- Do the automatic detection and selection of available channels with the channel group other than channel group 00.
- When there are unavailable channels due to extraneous radio wave and the channel could not be selected on some tuner modules, “NO CH” appears on the display of those tuner modules. If this happens, select the channel group with no interference from extraneous radio wave, and repeat the procedure above.

Setting the monitor level

The procedure below can be performed with the portable diversity tuner (URX-P2) only.

You can set the monitor level for monitoring the tuner output within the range of 01 to 24.

- 1** While the parameters on the display section are not flashing, press the + or – button once.

The monitor level indication appears in the display section.



- 2** Press the + button to increase the monitor level, or press the – button to decrease the level.

When you leave the tuner for about two seconds or more or press down the SET button for more than one second, current monitor level setting is stored in memory and the normal display resumes. Note that monitor level setting is effective after you turn off the tuner, then turn it on again.

Resetting the accumulated use time indication

The procedure below can be performed with the portable diversity tuner (URX-P2) only.

The accumulated use time is the total time (in hours and minutes) that the tuner has been used. It is recorded whenever the tuner is on.

If you reset the indication to “00:00” when you replace the batteries, this shows the accumulated battery use time.

- 1 Press down the SET button for more than one second.

Keep pressing the SET button until the display section parameters start to flash.

- 2 Press the SET button repeatedly until the accumulated time indication appears in the display section.

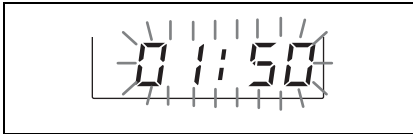

- 3 Press the – button.

The time indication resets to “00:00.” While “00:00” is still displayed, you can return to previous value by pressing the + button.

- 4 Leave the tuner for about 10 seconds or press down the SET button for more than one second.

The time indication stops flashing and the results are stored in memory.

Transmitter Settings

Setting the transmission channel

The procedure below is the same for all UWP series transmitters (UTX-B2/H2/P1).

For U30/U42/CE62/CE67 models:

Refer to the pdf files “Sony Wireless Microphone System Frequency List” on the supplied CD-ROM for details on the selectable channel groups and channels.

For AU66/E models:

Refer to the supplied leaflet “Sony Wireless Microphone System Frequency List” for details on the selectable channel groups and channels.

- 1 Turn on the transmitter while pressing down the SET button.

Keep pressing the SET button until the display section parameters that were displayed when the unit was last turned off start to flash.

- 2 Press the SET button repeatedly until the channel number (or frequency) indication appears.

- 3 Press the + or – button to select the channel number (or frequency).

Pressing the + button cycles the indication in the order shown in the tables in the pdf files “Sony Wireless Microphone System Frequency List” on the supplied CD-ROM (for U30, U42, CE62, and CE67 models) or in the supplied leaflet “Sony Wireless

Microphone System Frequency List” (for AU66 and E models).

Pressing the – button cycles the indications in the opposite direction. Hold down the + or – button to change the channel number (or frequency) faster.

Notes on the European model

Select the group number before selecting the channel number as follows.

- 1) While the left two digits are flashing, select the group number by pressing the + or – button.
- 2) While the desired group number appears, press the SET button. The right four digits start to flash to allow the selection of the channel number.
- 3) Select the channel number by pressing the + or – button.

Group selection	Channel selection	Frequency selection
0062 17	0062 17	800 1251
↓ ↑	↓ ↑	↓ ↑
62 00 1	0062 18	800 2501
↑: + button	↓: – button	

Group, channel, and frequency selection examples for CE62 model are shown.

- 4) When the desired channel number (or frequency) appears, set the POWER switch to OFF to complete the setting, or press the SET button to set other items.

The results are stored in memory. The stored channel number (or frequency) will appear in the display section the

next time you turn on the transmitter by setting the POWER switch to ON.

Notes

- When you are setting the transmission channel, the transmitter cannot be used to transmit signals.
- Do not remove the batteries while setting the transmission channel. If they are inadvertently removed, re-insert them immediately and redo the procedure “Setting the transmission channel” from step 1.
- Make sure that the selected channel is the same on the transmitter and tuner being used in the same system.
- If you turn off the transmitter and then immediately turn it on right after setting the transmission channel, the unit may not operate normally. Wait a few seconds before turning it on again.

Setting the RF output power level

The procedure below can be performed with the body-pack transmitter (UTX-B2) and the hand-held microphone (UTX-H2).

For U30/U42/CE62/CE67/AU66 models:
The RF power output level can be set at 30 mW (“H”) or 5 mW (“L”).

For E model:
The RF power output level can be set at 10 mW (“H”) or 2 mW (“L”).

You can select the RF output power level from “H” or “L” in setting mode. Set the RF output level to “L” for simultaneous operation of multiple channels, and set it to “H” for long-distance operation.

- 1) Turn on the transmitter while pressing down the SET button.

- 2 Press the SET button repeatedly until the RF output level indication appears in the display section.



- 3 Press the + button to select "H," or press the – button to select "L."
- 4 Set the POWER switch to OFF to complete the setting, or press the SET button to set other items.

The results are stored in memory. The change becomes effective the next time you turn on the transmitter by setting the POWER switch to ON.

Setting the attenuation level of the audio input

The procedure below is the same for all UWP series transmitters (UTX-B2/H2/P1).

The attenuation level can be set during signal transmission.

Note

When the MIC/LINE input selector of the UTX-B2 or the INPUT selector of the UTX-P1 is set to LINE position, attenuation level of the audio input is always 0 dB and cannot be reset. In this case, adjust the output level on the audio source device.

- 1 **Do the following while there is no signal transmission.**

Turn on the transmitter while pressing down the SET button, and press the SET button repeatedly until the

attenuation level indication appears in the display section.

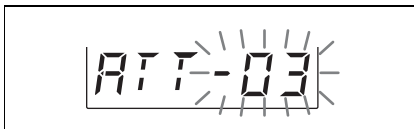

Do the following while there is signal transmission.

Press the SET button repeatedly until the attenuation level indication appears in the display section.

- 2 Press the + or – button to select the attenuation level.

The selectable range is from 0 dB to 21 dB in steps of 3 dB (the factory setting is 0 dB).

- 3 **Do the following while there is no signal transmission.**

Set the POWER switch to OFF to complete the setting, or press the SET button to set other items.

The results are stored in memory. The change becomes effective the next time you turn on the transmitter by setting the POWER switch to ON.

Resetting the accumulated use time indication

The procedure below is the same for all UWP series transmitters (UTX-B2/H2/P1).

- 1 Turn on the transmitter while pressing down the SET button.
- 2 Perform step 2 and 3 in "Resetting the accumulated use time indication" on page 54.

- 3** Set the POWER switch to OFF to complete the setting, or press the SET button to set other items.

The results are stored in memory. The change becomes effective the next time you turn on the transmitter by setting the POWER switch to ON.

System Configurations

Note

Production of the peripheral and relating devices may have been discontinued. Upon selecting the devices to be used with this product, consult your nearest Sony representative or the dealer from whom you purchased the product.

Configuration examples of the UWP-V1/V2/X7/X8

Sample configuration for ENG (Electronic News Gathering) or EFP (Electronic Field Production) with a camcorder

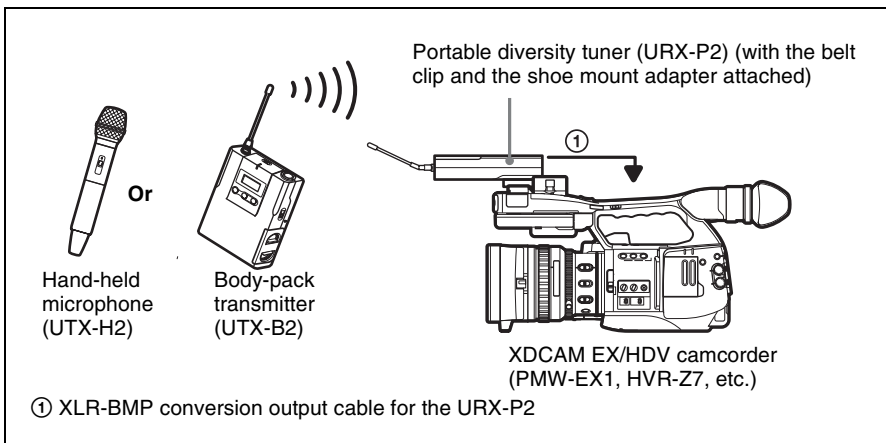

Sample configuration for AV presentations

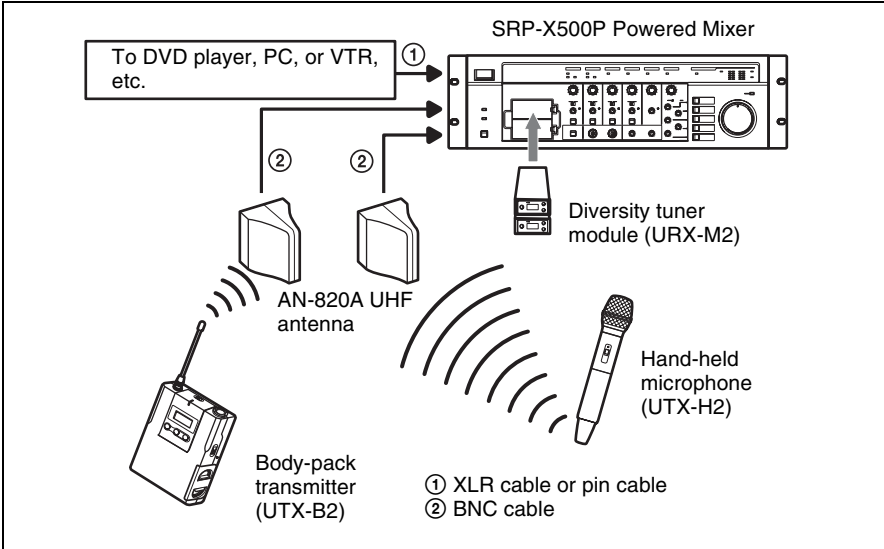

Sample configuration of a PA system

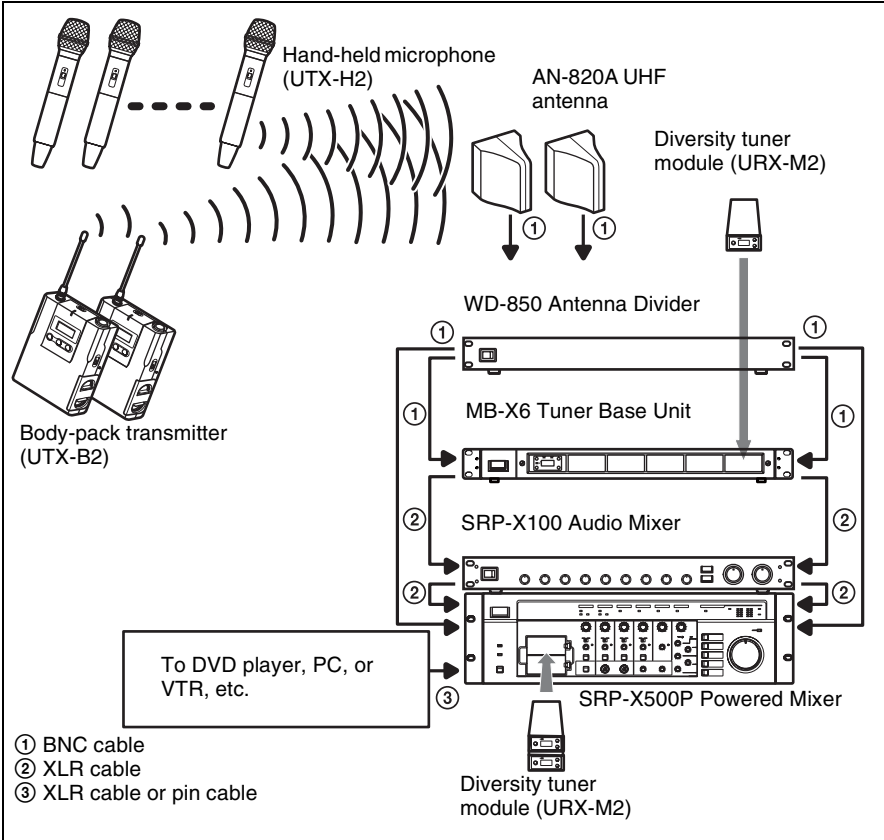

Configuration example of the UWP-V6

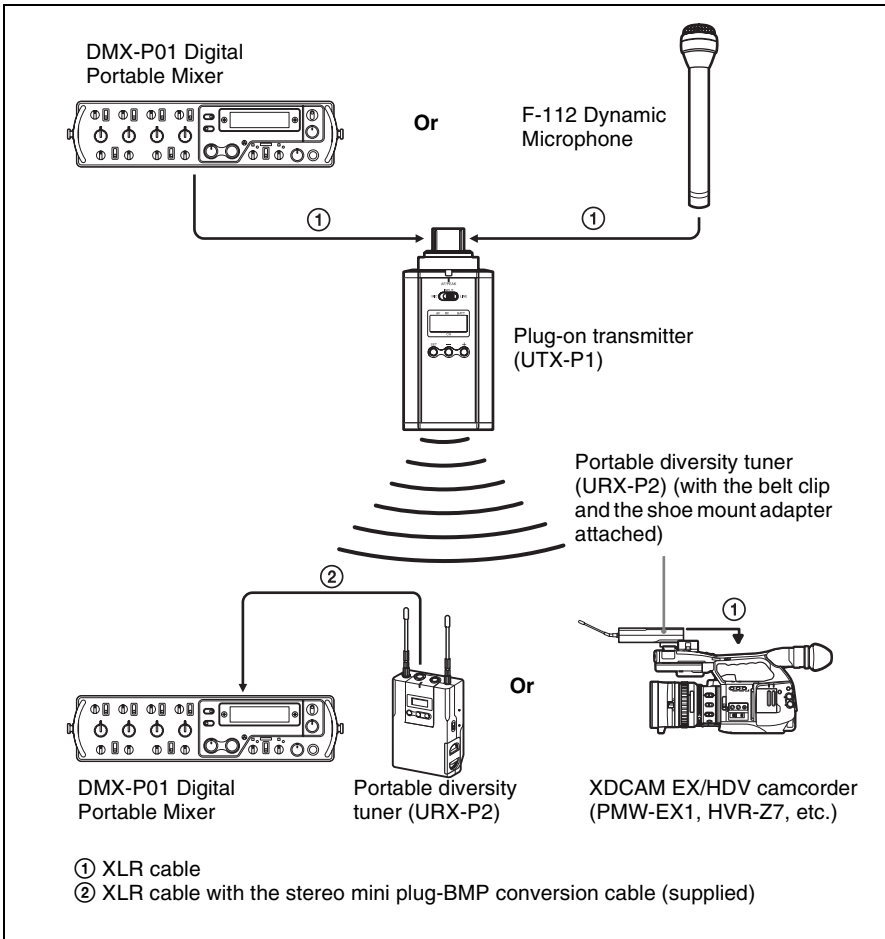

Error Messages

When a problem occurs, one of the following error messages may appear on the display.

Messages	Meanings	Remedy
Err 01	An error has occurred in the backup memory data.	Contact your Sony dealer.
Err 02	The PLL synthesized circuit is abnormal.	Restart the unit. If the message appears again, contact your Sony dealer.
Err 03 ¹⁾	The battery voltage exceeds the allowable limit.	Use the specified battery.

1) Body-pack transmitter (UTX-B2)/hand-held microphone (UTX-H2)/plug-on transmitter (UTX-P1)/portable diversity tuner (URX-P2) only.

Troubleshooting

If you have any problem using the UWP series components, use the following checklist. Should any problem persist, consult your Sony dealer.

Symptom	Meanings	Remedy
The unit does not turn on. ¹⁾	The polarity orientation of the batteries in the battery compartment is incorrect.	Insert the batteries with the correct polarity orientation.
	The batteries are exhausted.	Replace the batteries with new ones.
	The battery terminals in the transmitter are dirty.	Clean the + and – terminals with a cotton swab.
The batteries become drained quickly. ¹⁾	The batteries are exhausted.	Replace the batteries with new ones.
	Manganese batteries are being used.	Use alkaline batteries. The battery life of a manganese battery is less than half that of an alkaline battery.
	The UWP series components is being used under cold conditions.	The batteries drain quickly under cold conditions.
The channel cannot be changed.	An attempt was made to change the channel by pressing the SET button only.	Restart the unit while holding down the SET button. Then change the channel with the + and – buttons.
There is no sound.	The channel setting on the transmitter is different from that on the tuner.	Use the same channel setting on both the transmitter and tuner.
	The RF indicator on the tuner does not turn on.	Confirm that the transmitter is turned on.
	The line input is selected on the transmitter. ²⁾	Select the microphone input on the transmitter.
	The tuner module is installed into/uninstalled from the MB-X6/SRP-X500P while the MB-X6/SRP-X500P is turned on.	Turn off the MB-X6/SRP-X500P. Then, turn it on again.

Symptom	Meanings	Remedy
The sound is weak.	The attenuation level on the transmitter is too high.	The input level of the transmitter is low. Press the – button on the transmitter in attenuation level setting mode to decrease the attenuation level.
	The volume on the amplifier or mixer is low.	Adjust the volume.
	The line input is selected on the transmitter. ²⁾	Select the microphone input on the transmitter.
There is distortion in the sound.	The attenuation level of the transmitter is too low.	The input level of the tuner is extremely high. Press the + button on the transmitter in attenuation level setting mode to raise the attenuation level.
	The transmitter and the tuner are set to different channels.	Set the transmitter to the same channel.
	Headphones with a monaural mini jack is used. ³⁾	Use the headphones with a stereo mini jack.
	The line output signal is input to the transmitter when the MIC/LINE input selector (or INPUT selector) is set to MIC position. ⁴⁾	Set the MIC/LINE input selector (or INPUT selector) to LINE position.
There is sound interruption or noise.	The transmitter and the tuner are set to different channels.	Set the transmitter to the same channel as the tuner.
	Two or more transmitters are set to the same channel.	Set each transmitter to a different channel.
	The transmitters are not set to the channels within the same channel group.	The channel plan which the UWP series components use is set so that no signal interference occurs when 2 or more transmitters are used simultaneously. Set each transmitter to a different channel within the same channel group.
	Two or more UWP series packages are operated at close channels.	<ul style="list-style-type: none"> • Select channels within the same channel group (except channel group 00). • Use the channels at least 2-channel intervals (250 kHz).

Symptom	Meanings	Remedy
The RF indications on the tuner appear (the RF indicator lights up) even when the transmitter is off.	Jamming radio waves are being received.	Locate the channel group that is unaffected by jamming radio waves and use that channel group.

- 1) Body-pack transmitter (UTX-B2)/hand-held microphone (UTX-H2)/plug-on transmitter (UTX-P1)/portable diversity tuner (URX-P2) only
- 2) Body-pack transmitter (UTX-B2) only
- 3) Portable diversity tuner (URX-P2) only
- 4) Body-pack transmitter (UTX-B2)/plug-on transmitter (UTX-P1) only

Important Notes on Use

On usage and storage

- Operating the UWP series components near electrical equipment (motors, transformers, or dimmers) may cause it to be affected by electromagnetic induction. Keep the UWP series components as far from such equipment as possible.
- The presence of the lighting equipment may produce electrical interference over the entire frequency range. Position the UWP series components so that interference is minimized.
- To avoid degradation of the signal to-noise ratio, do not use the UWP series components in noisy places or in locations subject to vibration, such as the following:
 - near electrical equipment, such as motors, transformers or dimmers
 - near air conditioning equipment or places subject to direct air flow from an air conditioner
 - near public address loudspeakers
 - where adjacent equipment might knock against the tuner

Keep the UWP series components as far from such equipment as possible or use buffering material.

On cleaning

Clean the surface and the connectors of the UWP series components with a dry, soft cloth. Never use thinner, benzene, alcohol or any other chemicals, since these may mar the finish.

To prevent electromagnetic interference from portable communication devices

The use of portable telephones and other communication devices near the UWP series components may result in malfunction and interference with audio signals. It is recommended that portable communication devices near the UWP series components be turned off.

Specifications

Design and specifications are subject to change without notice.

Note

Always verify that the unit is operating properly before use. SONY WILL NOT BE LIABLE FOR DAMAGES OF ANY KIND INCLUDING, BUT NOT LIMITED TO, COMPENSATION OR REIMBURSEMENT ON ACCOUNT OF THE LOSS OF PRESENT OR PROSPECTIVE PROFITS DUE TO FAILURE OF THIS UNIT, EITHER DURING THE WARRANTY PERIOD OR AFTER EXPIRATION OF THE WARRANTY, OR FOR ANY OTHER REASON WHATSOEVER.

Transmitters (UTX-B2/H2/P1)

Items common to all transmitters

Oscillator type

Crystal-controlled PLL synthesizer

Carrier frequencies

Model available in USA: 566 to 590 MHz (U30 model), 638 to 662 MHz (U42 model)

Model available in Europe: 798 to 822 MHz (CE62 model), 838 to 862 MHz (CE67 model)

Model available in Australia: 792 to 806 MHz (AU66 model)

Model available in Thailand and Taiwan: 794 to 806 MHz (E model)

Operating frequency band

Model available in USA and Europe: 24 MHz BW

Model available in Australia: 14 MHz BW

Model available in Thailand and Taiwan: 12 MHz BW

Pre-emphasis

50 μ s

Distortion

1.0% or less (-60 dBV, 1 kHz input)

Signal-to-noise ratio

60 dB or more

Tone signal

32 kHz

Attenuation

0 to 21 dB, in 3-dB steps

Display

Channel, frequency, audio level, RF level, accumulated use time

Power requirements

3.0 V DC (two LR6/AA size alkaline batteries)

Operating temperature

0°C to 50°C (32°F to 122°F)

Storage temperature

-20°C to +55°C (-4°F to +131°F)

Body-pack transmitter (UTX-B2)

Antenna

$1/4\lambda$ wave length wire

Audio input connector

3.5-mm dia. mini jack

Reference audio input level

-60 dBV (at 0 dB attenuation level)

RF output level

30 mW/5 mW selectable (for model available in USA, Europe, and Australia)

10 mW/2 mW selectable (for model available in Thailand and Taiwan)

Reference deviation

± 7 kHz (-60 dBV, 1 kHz input)

Frequency response

40 Hz to 18 kHz

Indicator

AF/PEAK level

Battery life (measured with two Sony LR6/

AA size alkaline batteries at
25°C (77°F))

Approx. 8 hours with output power
of 30 mW (for model available
in USA, Europe, and Australia)

Approx. 10 hours with output
power of 10 mW (for model
available in Thailand and
Taiwan)

Dimensions

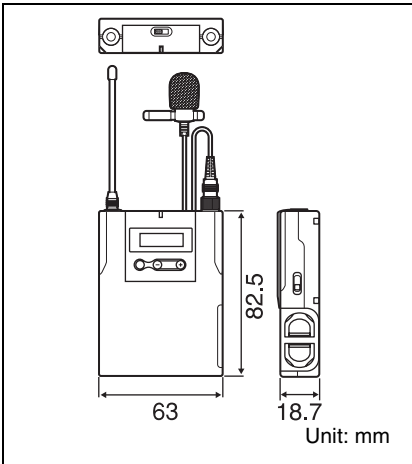

63 × 82.5 × 18.7 mm (2 1/2 × 3 1/4
× 3/4 inches) (w/h/d) (excluding
the antenna)

Mass Approx. 145 g (5.1 oz) including
batteries

Hand-held microphone (UTX-H2)

Microphone unit
Dynamic

Directivity
Unidirectional

Antenna
1/4λ wave length wire (internal)

RF output level

30 mW/5 mW selectable (for model
available in USA, Europe, and
Australia)

10 mW/2 mW selectable (for model
available in Thailand and
Taiwan)

Reference deviation
±7 kHz (-60 dBV, 1 kHz input)

Frequency response
50 Hz to 18 kHz

Indicator

Power on

Battery life (measured with two Sony LR6/
AA size alkaline batteries at
25°C (77°F))

Approx. 8 hours with output power
of 30 mW (for model available
in USA, Europe, and Australia)

Approx. 10 hours with output
power of 10 mW (for model
available in Thailand and
Taiwan)

Dimensions

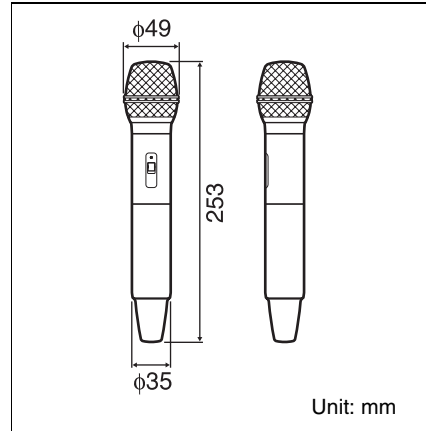

φ 49 × 253 mm (1 15/16 × 10 inches)
(dia/length)

Mass Approx. 308 g (11 oz) including
batteries

Plug-on transmitter (UTX-P1)

- RF output level
50 mW
- Reference deviation
 ± 10 kHz
- Reference audio input level
MIC: -60 dBV
LINE: $+4$ dBu
- Audio input connector
XLR-3-11 type
- Indicator
AF/PEAK level
- Battery life
Approx. 6 hours (measured with
two Sony LR6/AA size alkaline
batteries at 25°C (77°F))
- Frequency response
50 Hz to 18 kHz
- Dimensions

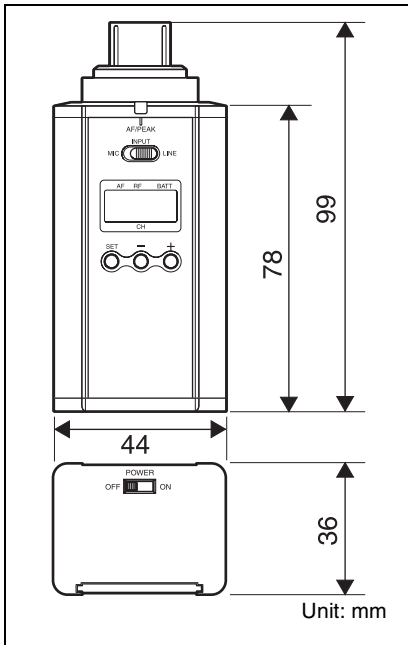

44 × 99 × 36 mm ($1\frac{3}{4} \times 4 \times 1\frac{7}{16}$ inches) (w/h/d) (including the audio input connector)

Mass Approx. 185 g (6.5 oz) including batteries

Tuners (URX-P2/M2)

Items common to all tuners

- Type of reception
Space diversity
- Oscillator type
Crystal-controlled PLL synthesizer
- Reception frequencies
Model available in USA: 566 to 590 MHz (U30 model), 638 to 662 MHz (U42 model)
Model available in Europe: 798 to 822 MHz (CE62 model), 838 to 862 MHz (CE67 model)
Model available in Australia: 792 to 806 MHz (AU66 model)
Model available in Thailand and Taiwan: 794 to 806 MHz (E model)
- Operating frequency band
Model available in USA and Europe: 24 MHz BW
Model available in Australia: 14 MHz BW
Model available in Thailand and Taiwan: 12 MHz BW
- Signal-to-noise ratio
60 dB or more
- De-emphasis
50 μs
- Reference deviation
 ± 5 kHz
- Distortion
1.0% or less at 1 kHz modulation
- Tone signal
32 kHz
- Indicator
RF input level
- Operating temperature
 0°C to 50°C (32°F to 122°F)
- Storage temperature
 -20°C to $+55^{\circ}\text{C}$ (-4°F to $+131^{\circ}\text{F}$)

Portable diversity tuner (URX-P2)

Antenna

1/4λ wave length wire

Squelch level

15 dBμ

Audio output level

-58 dBm

Audio output connector

3.5 mm dia. mini jack

Headphones output level

5 mW (16 ohms)

Display

Channel, frequency, audio level,
RF level, accumulated use time,
monitor level

Power requirements

3.0 V DC (two LR6/AA size
alkaline batteries)

Battery life

Approx. 6 hours (measured with
two Sony LR6/AA size alkaline
batteries at 25 °C (77°F))

Reference deviation

±5 kHz (at 1 kHz modulation)

Frequency response

40 Hz to 18 kHz

Dimensions

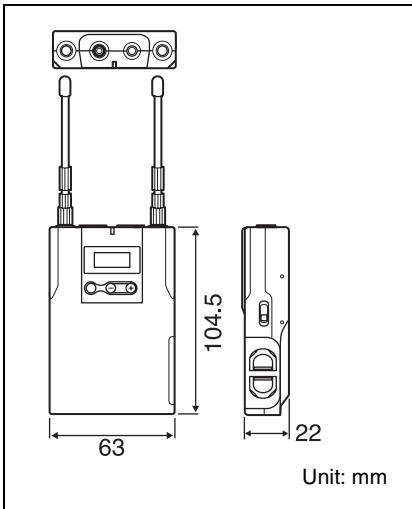

63 × 104.5 × 22 mm (2 1/2 × 4 1/8 ×
7/8 inches) (w/h/d) (excluding
the antennas)

Mass Approx. 205 g (7.2 oz) including
batteries

Diversity tuner module (URX-M2)

Squelch level

25 dBμ

Display

Channel, frequency

Reference deviation

±5 kHz (at 1 kHz modulation)

Frequency response

50 Hz to 18 kHz

Dimensions

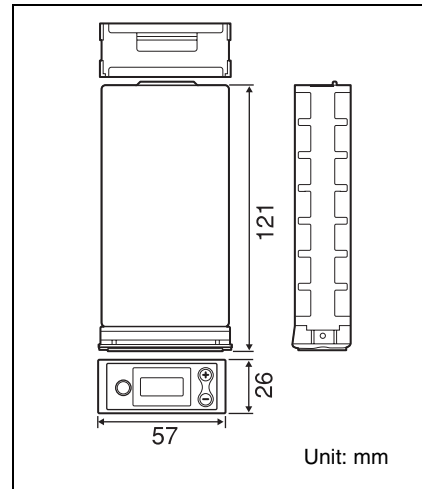

57 × 26 × 121 mm (2 1/4 × 1 1/16 ×
4 7/8 inches) (w/h/d)

Mass Approx. 150 g (5 oz)

<http://www.sony.net/>

Sony Corporation
Printed in Korea

Download from [Www.Somanuals.com](http://www.Somanuals.com). All Manuals Search And Download.

Free Manuals Download Website

<http://myh66.com>

<http://usermanuals.us>

<http://www.somanuals.com>

<http://www.4manuals.cc>

<http://www.manual-lib.com>

<http://www.404manual.com>

<http://www.luxmanual.com>

<http://aubethermostatmanual.com>

Golf course search by state

<http://golfingnear.com>

Email search by domain

<http://emailbydomain.com>

Auto manuals search

<http://auto.somanuals.com>

TV manuals search

<http://tv.somanuals.com>