

MZ-R909

SERVICE MANUAL

Ver 1.0 2001.08

E Model
Tourist Model



US and foreign patents licensed from Dolby Laboratories.

Model Name Using Similar Mechanism	NEW
Mechanism Type	MT-MZR909-171
Optical Pick-up Name	LCX-4R

SPECIFICATIONS

Audio playing system

MiniDisc digital audio system

Laser diode properties

Material: GaAlAs

Wavelength: $\lambda = 790 \text{ nm}$

Emission duration: continuous

Laser output: less than $44.6 \mu\text{W}$

(This output is the value measured at a distance of 200 mm from the lens surface on the optical pick-up block with 7 mm aperture.)

Recording and playback time

When using MDW-80:

Maximum 160 min. in monaural

Maximum 320 min. in stereo

Revolutions

350 rpm to 2,800 rpm (CLV)

Error correction

ACIRC (Advanced Cross Interleave Reed Solomon Code)

Sampling frequency

44.1 kHz

Sampling rate converter

Input: 32 kHz/44.1 kHz/48 kHz

Coding

ATRAC (Adaptive Transform Acoustic Coding)

ATRAC3 — LP2

ATRAC3 — LP4

Modulation system

EFM (Eight to Fourteen Modulation)

Number of channels

2 stereo channels

1 monaural channel

Frequency response

20 to 20,000 Hz $\pm 3 \text{ dB}$

Wow and Flutter

Below measurable limit

Inputs

Microphone: stereo mini-jack, minimum input level 0.25 mV

Line in¹⁾: stereo mini-jack, minimum input level 49 mV

Optical (Digital) in¹⁾: optical (digital) mini-jack

Outputs

ϕ /LINE OUT²⁾: stereo mini-jack

headphones/earphones: maximum output level 5 mW + 5 mW, load impedance 16 ohm
LINE OUT: 194 mV, load impedance 10 kilohm

Power requirements

Sony AC Power Adaptor connected at the DC IN 3V jack:

230 - 240 V AC, 50 Hz (Hong kong model)

100 - 240 V AC, 50/60 Hz (Other models)

Nickel metal hydride rechargeable battery NH-14WM(A) 1.2V 1350 mAh (MIN) Ni-MH
LR6 (size AA) alkaline battery

Dimensions³⁾

Approx. 78.9 \times 72.0 \times 17.1 mm (w/h/d)
(3 1/8 \times 2 7/8 \times 1 1/16 in.)

Mass

Approx. 110 g (3.9 oz) the recorder only

¹⁾The LINE IN (OPT) jack is used to connect either a digital (optical) cable or a line (analog) cable.

²⁾The ϕ /LINE OUT jack connector either headphones/earphones or a line cable.

³⁾Measured in accordance with JEITA.

Battery operating time

Battery life¹⁾

When recording²⁾

(Unit: approx hours)(JEITA³⁾)

Batteries	SP Stereo	LP2 Stereo	LP4 Stereo
NH-14WM nickel metal hydride rechargeable battery ⁴⁾	8.5	11	14
LR6 (SG) Sony alkaline dry battery ⁵⁾	7.5	12	15
NH-14WM nickel metal hydride rechargeable battery ⁴⁾ + One LR6 (SG) ⁵⁾	20	28	37

¹⁾The battery life may be shorter due to operating conditions and the temperature of the location.

²⁾When you record, use a fully charged rechargeable battery. Recording time may differ according to the alkaline batteries.

— Continued on next page —

PORTABLE MINIDISC RECORDER

9-873-285-01
2001H0500-1
© 2001.8

Sony Corporation
Personal Audio Company
Shinagawa Tec Service Manual Production Group

SONY®

- ³⁾ Measured in accordance with the JEITA (Japan Electronics and Information Technology Industries Association) standard.
- ⁴⁾ When using a 100% fully charged rechargeable battery.
- ⁵⁾ When using a Sony LR6 (SG) "STAMINA" alkaline dry battery (produced in Japan).

When playing

(Unit: approx. hours)(JEITA¹⁾)

Batteries	SP Stereo	LP2 Stereo	LP4 Stereo
NH-14WM nickel metal hydride rechargeable battery ²⁾	24	27	31
LR6 (SG) Sony alkaline dry battery ³⁾	34	40	45
NH-14WM nickel metal hydride rechargeable battery ²⁾ + One LR6 (SG) ³⁾	64	75	84

- ¹⁾ Measured in accordance with the JEITA (Japan Electronics and Information Technology Industries Association) standard.
- ²⁾ When using a 100% fully charged rechargeable battery.
- ³⁾ When using a Sony LR6 (SG) "STAMINA" alkaline dry battery (produced in Japan)

Supplied accessories

- AC power adaptor (1)
- Headphones/earphones with a remote control (1)
- Battery charging stand (Assembly needed) (1)
- Rechargeable battery (1)
- Dry battery case (1)
- Rechargeable battery carrying case (1)
- Carrying pouch/carrying case with a belt clip (1)
- AC plug adaptor (Except HongKong model) (1)
- Optical cable (1)

On power sources

- Use house current, nickel metal hydride rechargeable battery, LR6 (size AA) battery, or car battery.
- For use in your house: For the supplied battery charging stand, use the AC power adaptor supplied with this recorder. Do not use any other AC power adaptor since it may cause the recorder to malfunction.

Polarity of the plug

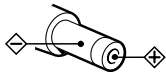

Design and specifications are subject to change without notice.

TABLE OF CONTENTS

1. SERVICING NOTES	3
2. GENERAL	4
3. DISASSEMBLY	
3-1. Disassembly Flow	5
3-2. Panel Assy, Bottom	5
3-3. Panel Assy, Upper Section	6
3-4. "LCD Module", "Panel Assy, Upper"	6
3-5. MAIN Board Assy	7
3-6. "Case Assy, Battery", "MAIN Board"	7
3-7. Strip, Ornamental	8
3-8. "MD Mechanism Deck (MT-MZR909-171)", "Chassis Assy, Set"	8
3-9. Service Assy, OP (LCX-4R)	9
3-10. Holder Assy	10
3-11. Motor, DC (Sled) (M602)	10
3-12. "Motor, DC (Spindle) (M601)", "Motor, DC (Over Write Head UP/DOWN) (M603)" ...	11
4. TEST MODE	12
5. ELECTRICAL ADJUSTMENTS	18
6. DIAGRAMS	
6-1. Block Diagram – SERVO Section –	34
6-2. Block Diagram – AUDIO Section –	35
6-3. Block Diagram – KEY CONTROL/DISPLAY/POWER SUPPLY Section –	36
6-4. Note for Printed Wiring Boards and Schematic Diagrams	37
6-5. Printed Wiring Board – Main Board (Component Side) –	38
6-6. Printed Wiring Board – Main Board (Conductor Side) –	39
6-7. Schematic Diagram – Main Board (1/4) –	40
6-8. Schematic Diagram – Main Board (2/4) –	41
6-9. Schematic Diagram – Main Board (3/4) –	42
6-10. Schematic Diagram – Main Board (4/4) –	43
6-11. IC Pin Function Description	48
7. EXPLODED VIEWS	
7-1. Panel Section	54
7-2. Chassis Section	55
7-3. MD Mechanism Deck Section (MT-MZR909-171)	56
8. ELECTRICAL PARTS LIST	57

SAFETY-RELATED COMPONENT WARNING!!

COMPONENTS IDENTIFIED BY MARK \triangle OR DOTTED LINE WITH MARK \triangle ON THE SCHEMATIC DIAGRAMS AND IN THE PARTS LIST ARE CRITICAL TO SAFE OPERATION. REPLACE THESE COMPONENTS WITH SONY PARTS WHOSE PART NUMBERS APPEAR AS SHOWN IN THIS MANUAL OR IN SUPPLEMENTS PUBLISHED BY SONY.

SECTION 1 SERVICING NOTES

NOTES ON HANDLING THE OPTICAL PICK-UP BLOCK OR BASE UNIT

The laser diode in the optical pick-up block may suffer electrostatic break-down because of the potential difference generated by the charged electrostatic load, etc. on clothing and the human body.

During repair, pay attention to electrostatic break-down and also use the procedure in the printed matter which is included in the repair parts.

The flexible board is easily damaged and should be handled with care.

NOTES ON LASER DIODE EMISSION CHECK

Never look into the laser diode emission from right above when checking it for adjustment. It is feared that you will lose your sight.

NOTES ON HANDLING THE OPTICAL PICK-UP BLOCK (LCX-4R)

The laser diode in the optical pick-up block may suffer electrostatic break-down easily. When handling it, perform soldering bridge to the laser-tap on the flexible board. Also perform measures against electrostatic break-down sufficiently before the operation. The flexible board is easily damaged and should be handled with care.

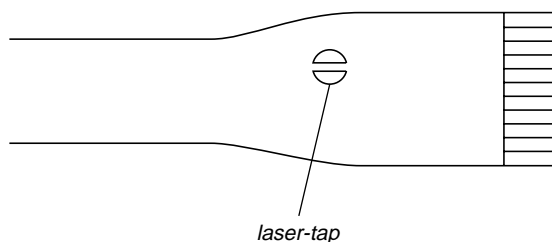

OPTICAL PICK-UP FLEXIBLE BOARD

CAUTION

Use of controls or adjustments or performance of procedures other than those specified herein may result in hazardous radiation exposure.

Notes on chip component replacement

- Never reuse a disconnected chip component.
- Notice that the minus side of a tantalum capacitor may be damaged by heat.

Flexible Circuit Board Repairing

- Keep the temperature of the soldering iron around 270 °C during repairing.
- Do not touch the soldering iron on the same conductor of the circuit board (within 3 times).
- Be careful not to apply force on the conductor when soldering or unsoldering.

- In performing the repair with the power supplied to the set, removing the MAIN board causes the set to be disabled. In such a case, fix a convex part of the open/close detect switch (S806 on MAIN board) with a tape in advance. Handle the FLEXIBLE board (overwrite head) with care, as it has been soldered directly to the MAIN board. In repairing the component side of MAIN board, connect the FLEXIBLE board (overwrite head) and the MAIN board with the lead wires in advance. (See page 7)

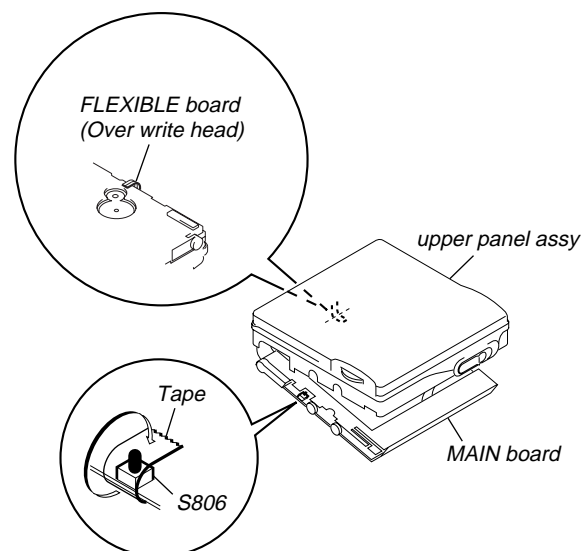

- Replacement of CXD2671-206GA (IC801) used in this set requires a special tool.
- The shipment data will be cleared when the NV is reset. Therefore, change the adjusted values following the Change of Adjusted Values immediately after the NV was reset. (See page 18)
- If the nonvolatile memory was replaced on the set, the modified program data must be written to the nonvolatile memory. In such a case, write the modified data that meets the microcomputer version following the patch data rewriting procedure at the replacement of nonvolatile memory. (See page 23)

UNLEADED SOLDER

Boards requiring use of unleaded solder are printed with the lead-free mark (LF) indicating the solder contains no lead.

(Caution: Some printed circuit boards may not come printed with the lead free mark due to their particular size)

LF: LEAD FREE MARK

Unleaded solder has the following characteristics.

- Unleaded solder melts at a temperature about 40 °C higher than ordinary solder. Ordinary soldering irons can be used but the iron tip has to be applied to the solder joint for a slightly longer time. Soldering irons using a temperature regulator should be set to about 350 °C. Caution: The printed pattern (copper foil) may peel away if the heated tip is applied for too long, so be careful!
- Strong viscosity. Unleaded solder is more viscous (sticky, less prone to flow) than ordinary solder so use caution not to let solder bridges occur such as on IC pins, etc.
- Usable with ordinary solder. It is best to use only unleaded solder but unleaded solder may also be added to ordinary solder.

Looking at controls

See pages in () for more details.

The recorder

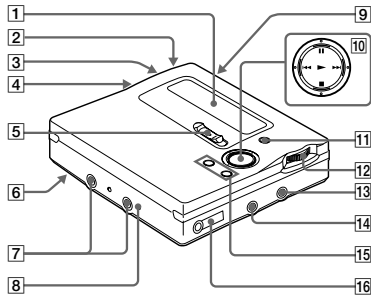

- 1 Display window (11) (32) (45) (55) (70)
- 2 T MARK button (39) (56) (67)
- 3 END SEARCH button (23) (31) (60)
- 4 Battery compartment (19)
- 5 REC (record) switch (23) (28)
- 6 HOLD switch (at the rear) (20) (74)
- 7 Terminals for attaching dry battery case (20)
- 8 DC IN 3V jack (19) (22)
- 9 OPEN button (21)
- 10 ► (play/enter) button (23) (25) (56)
- 11 || (pause) button (23) (25) (36) (43) (56)
- 12 ◀◀/▶▶ (REW/FF) buttons (23) (25) (32) (43) (56) (68)
- 13 ■ (stop)/CHG button (21) (23) (25) (40) (48) (56)
- 14 GROUP/CANCEL button (31) (43) (56) (61)
- 15 Jog dial (MENU/ENTER) (11) (29) (40) (42) (56) (70)
- 16 LINE IN (OPT) jack (22) (28)
- 17 MIC (PLUG IN POWER) jack (34)
- 18 The MIC (PLUG IN POWER) jack has a tactile dot.
- 19 VOL +/- button (25) (56)
- 20 The VOL +/- button has a tactile dot.
- 21 ◁ (headphones/earphones)/LINE OUT jack (20) (40) (53)

The display window of the recorder

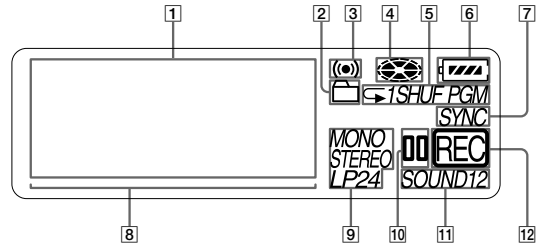

- 1 Character information display (11) (37) (45) (55) (70)
Displays the disc and track names, date, error messages, track numbers, etc.
- 2 Group indication (31) (43) (57)
- 3 Alarm indication (70)
- 4 Disc indication (32) (45) (55) (70)
Shows that the disc is rotating for recording, playing or editing an MD.
- 5 Play mode indication (45)
Shows the play mode (shuffle play, program play, repeat play, etc.) of the MD.
- 6 Battery indication (19) (75)
Shows approximate battery condition.
- 7 SYNC (synchro-recording) indication (32)
- 8 Level meter (36) (45)
- 9 STEREO (SP stereo), LP2 (LP2 stereo), LP4 (LP4 stereo), MONO (monaural) indication (29)
- 10 Pause indication
- 11 Sound indication (48)
Lights up when Digital Sound Preset is on.
- 12 REC indication (23) (36)
Lights up while recording. When flashing, the recorder is in record standby mode.

The headphones/earphones with a remote control

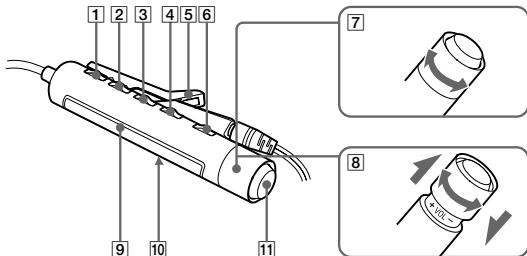

- 1 DISPLAY button (31) (38) (42) (53) (58) (71)
 - 2 PLAYMODE button (44) (47) (58)
 - 3 RPT/ENT (repeat/enter) button (47) (49)
 - 4 SOUND button (49)
 - 5 Clip
 - 6 || (pause) button (25) (42) (58) (61)
 - 7 Control (◀◀/▶▶) (25) (31) (42) (49) (58) (71)
▶▶▶▶ : play, AMS, FF
◀◀ : REW
Turn or turn and hold to play, fast forward, rewind, etc.
 - 8 Control (VOL +/-) (25) (58)
Pull and turn to adjust the volume.
 - 9 Display window (38) (47) (71)
 - 10 HOLD switch (20) (74)
 - 11 ■ (stop) button¹⁾ (25) (31) (42) (58) (71)
- ¹⁾May be used as the "Enter" button, depending on the function.

The display window of the remote control

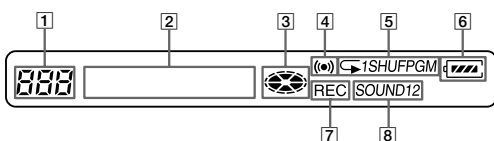

- 1 Track number display (38) (47) (71)
- 2 Character information display (38) (47) (53) (71)
- 3 Disc indication (38) (47) (71)
- 4 Alarm indication (71)
- 5 Play mode indication (47)
- 6 Battery level indication (38) (47) (71)
- 7 REC indication (23) (38)
- 8 SOUND indication (49)

SECTION 3 DISASSEMBLY

• This set can be disassembled in the order shown below.

3-1. DISASSEMBLY FLOW

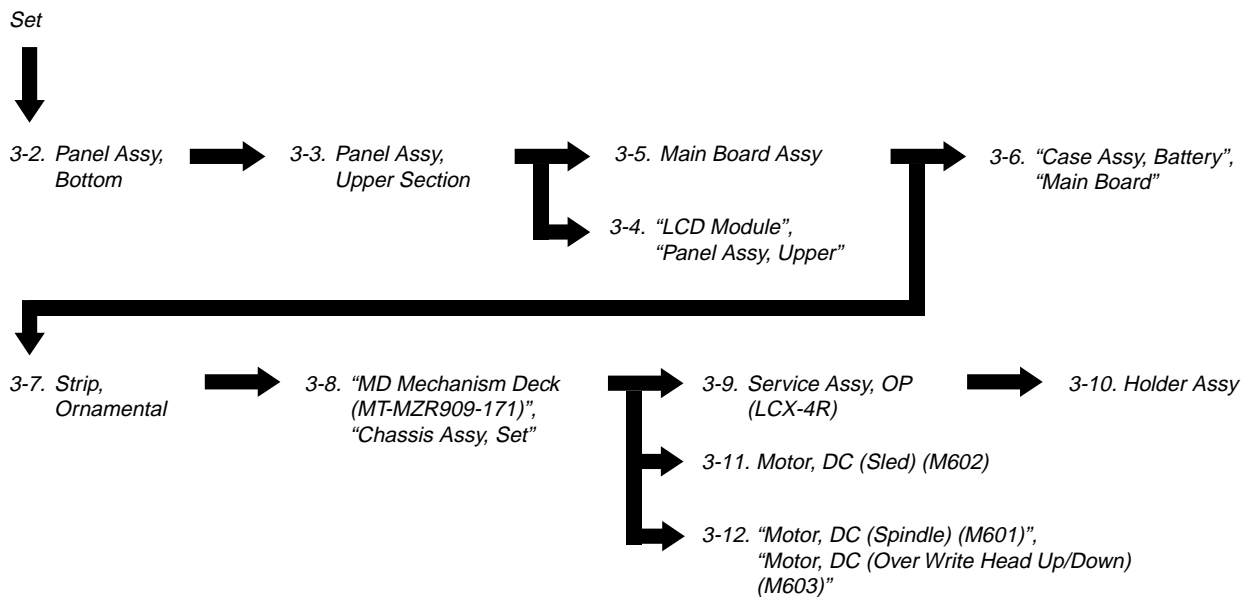

Note: Follow the disassembly procedure in the numerical order given.

3-2. PANEL ASSY, BOTTOM

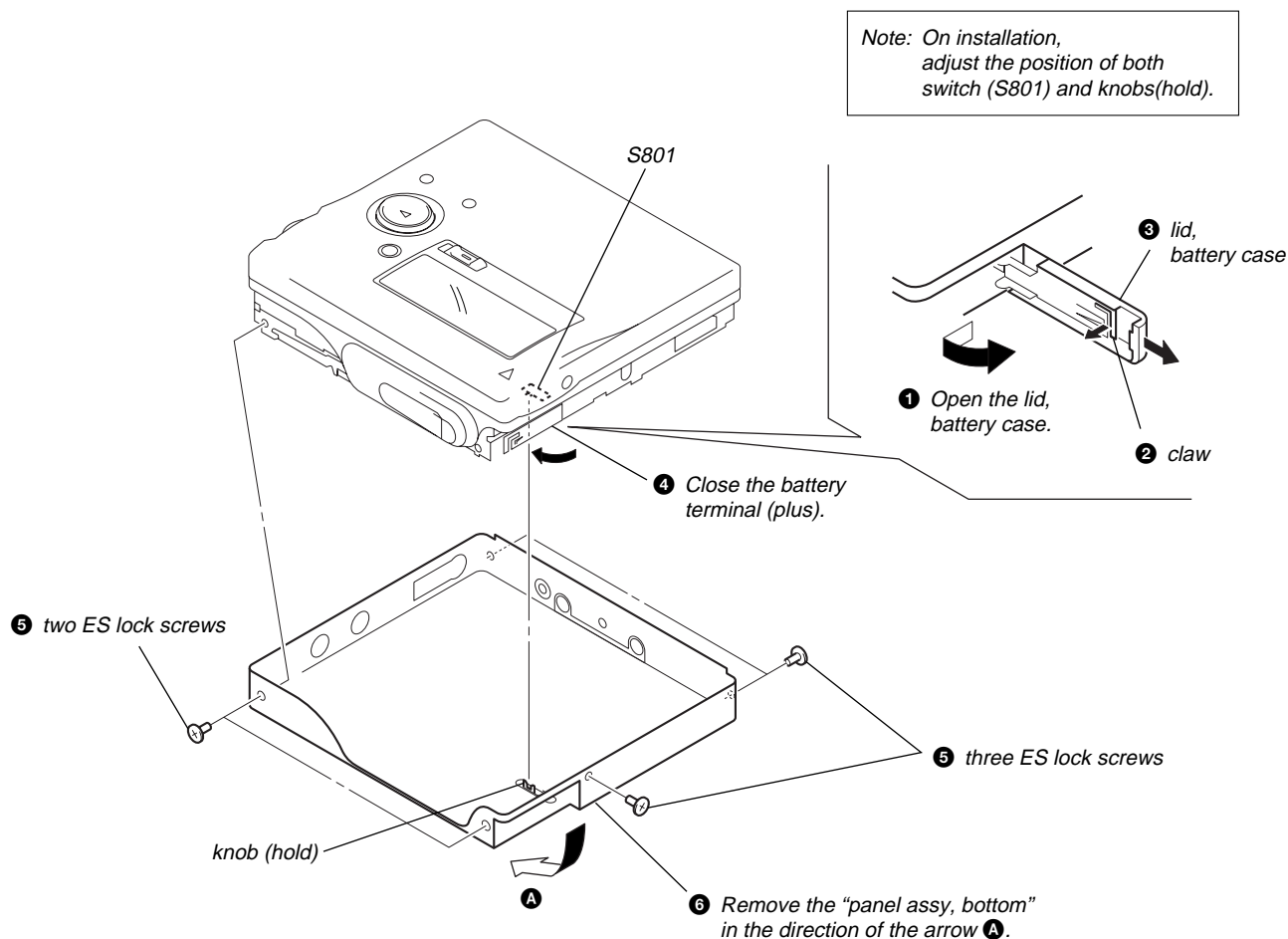

3-3. PANEL ASSY, UPPER SECTION

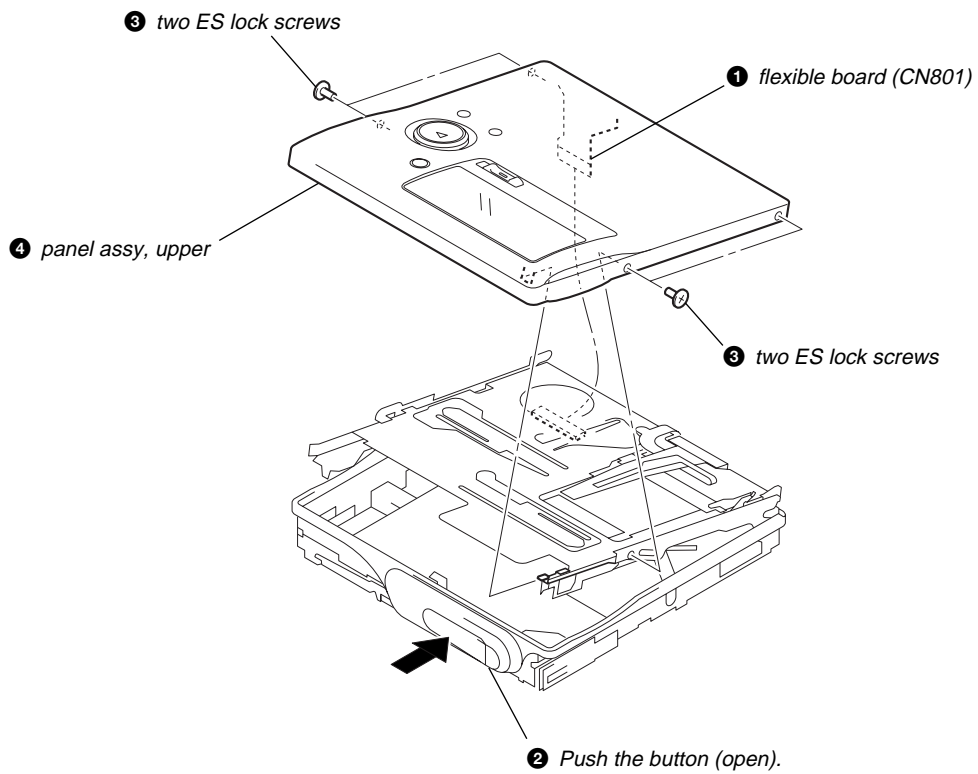

3-4. "LCD MODULE", "PANEL ASSY, UPPER"

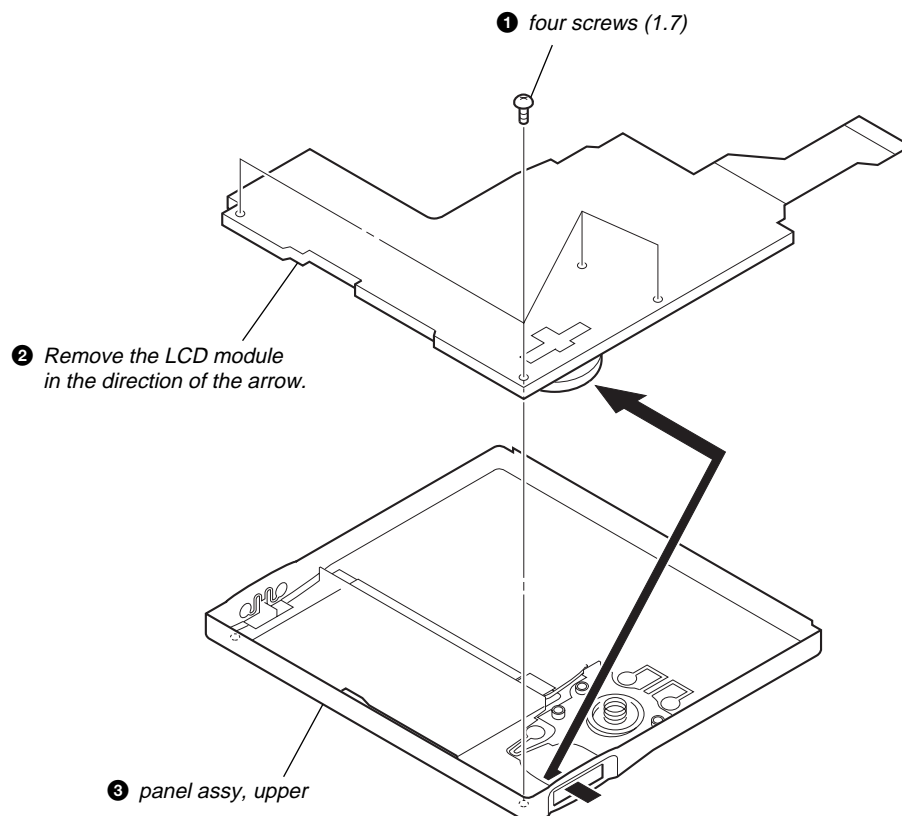

3-5. MAIN BOARD ASSY

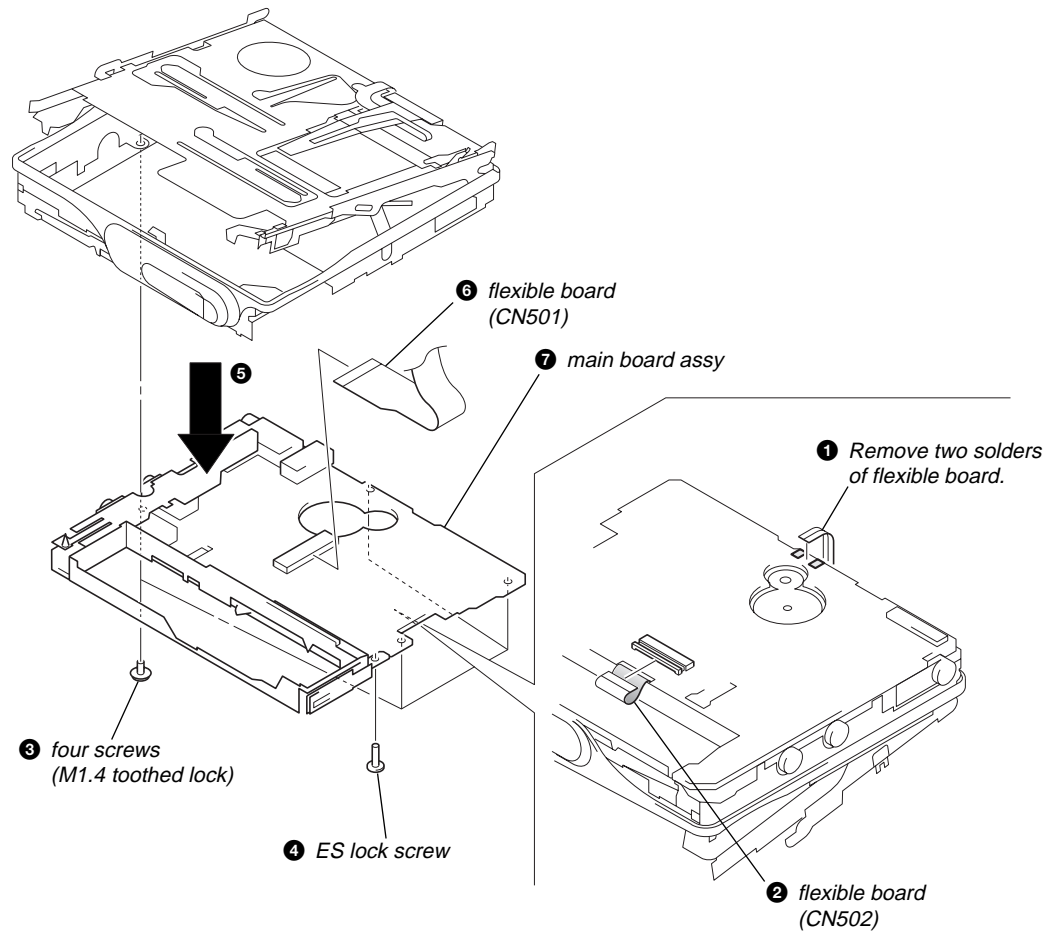

3-6. "CASE ASSY, BATTERY", "MAIN BOARD"

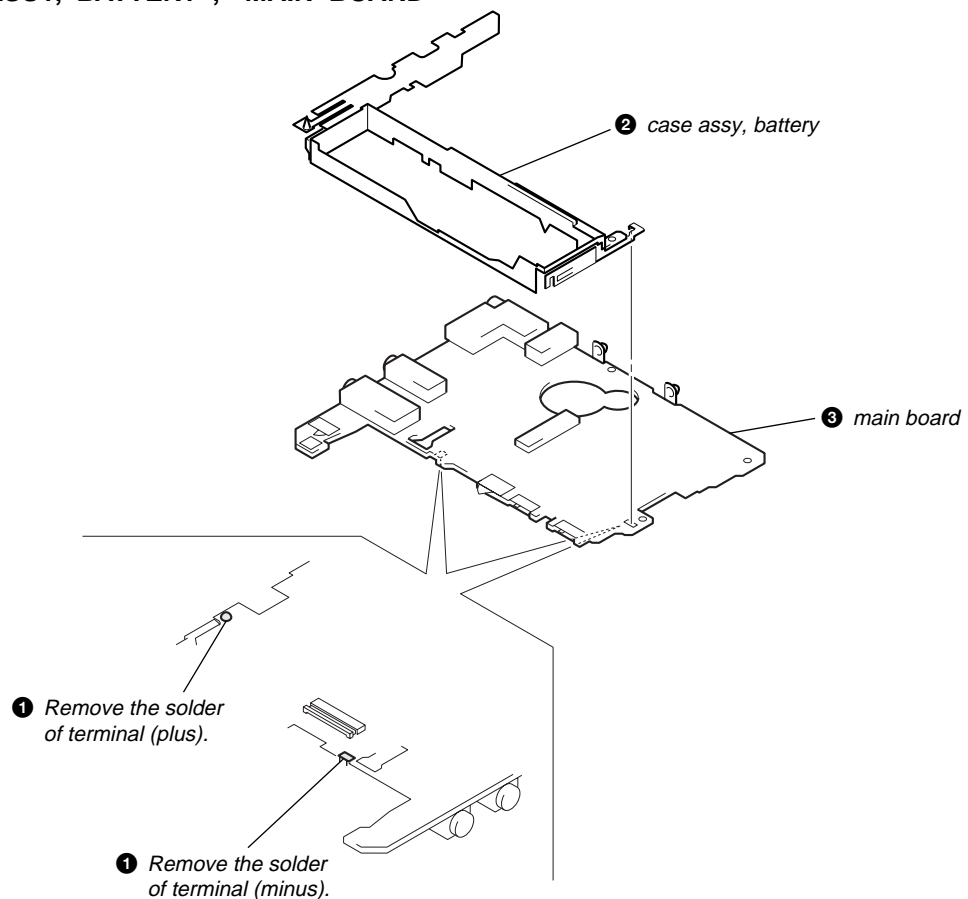

3-7. STRIP, ORNAMENTAL

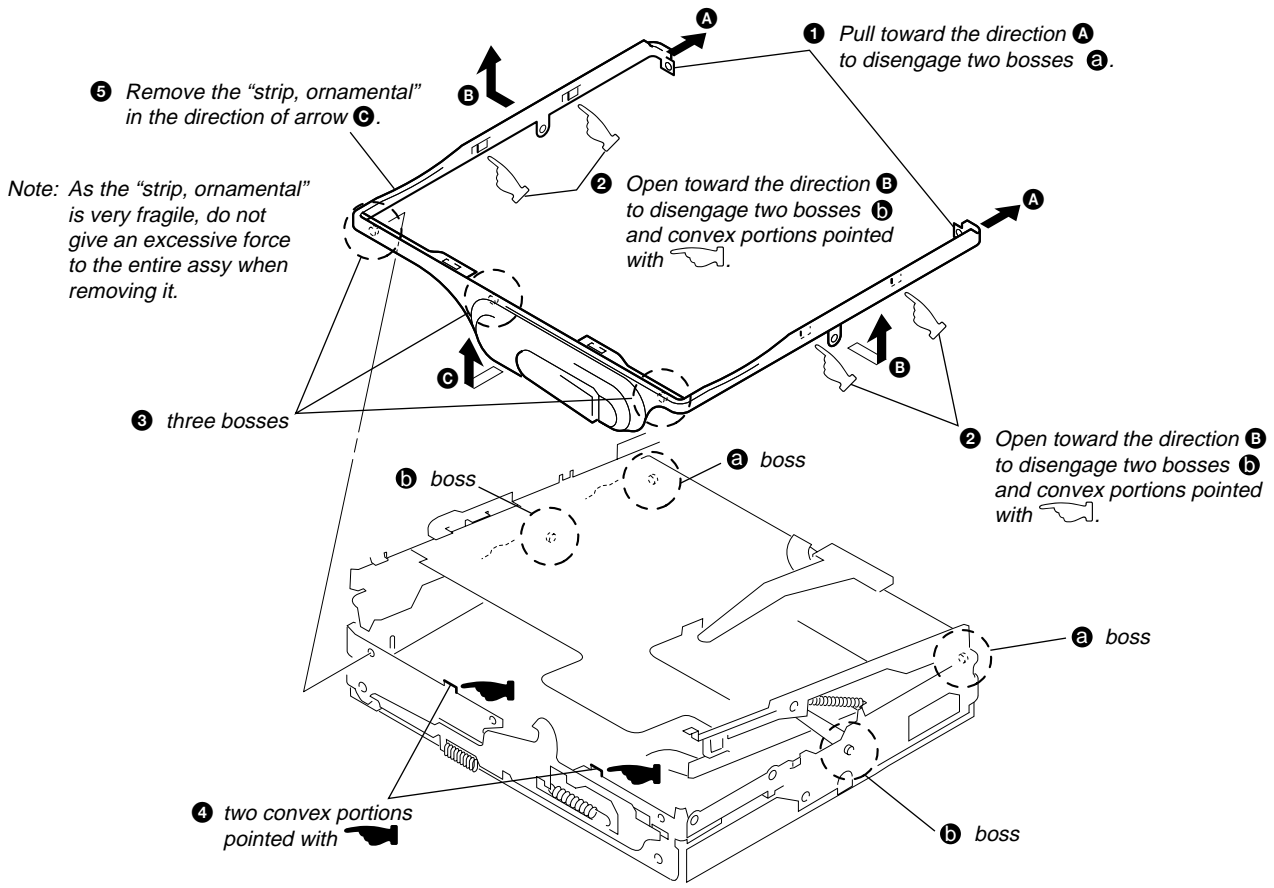

3-8. "MD MECHANISM DECK (MT-MZR909-171)", "CHASSIS ASSY, SET"

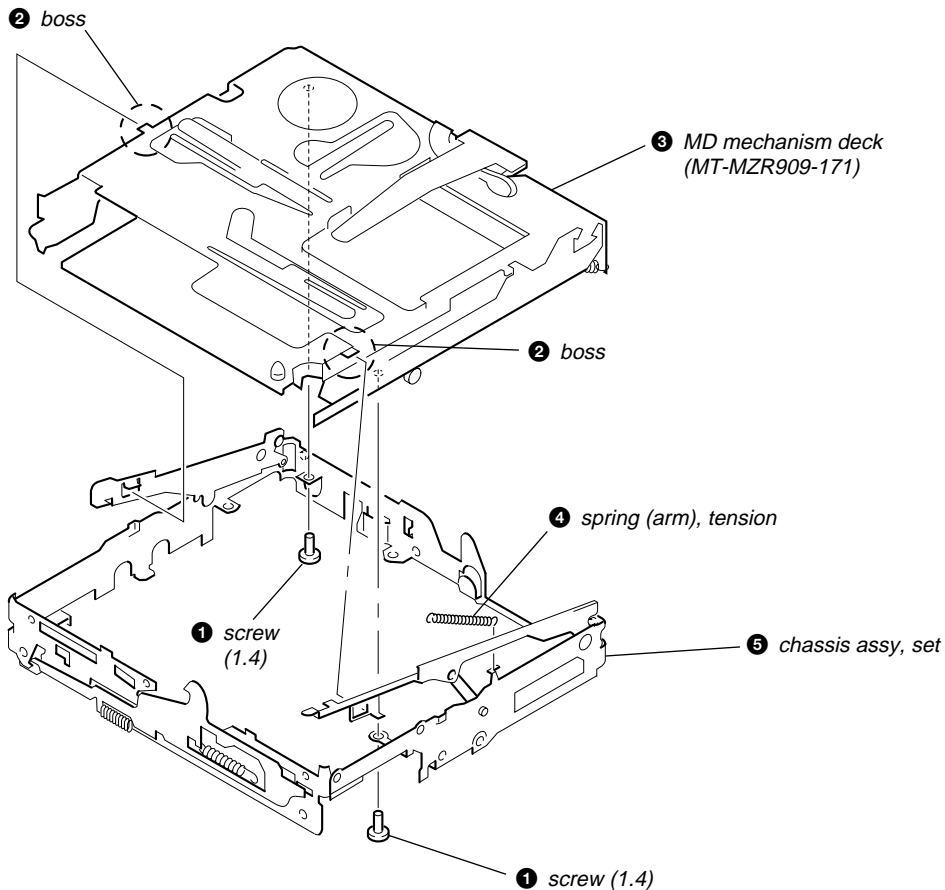

3-9. SERVICE ASSY, OP (LCX-4R)

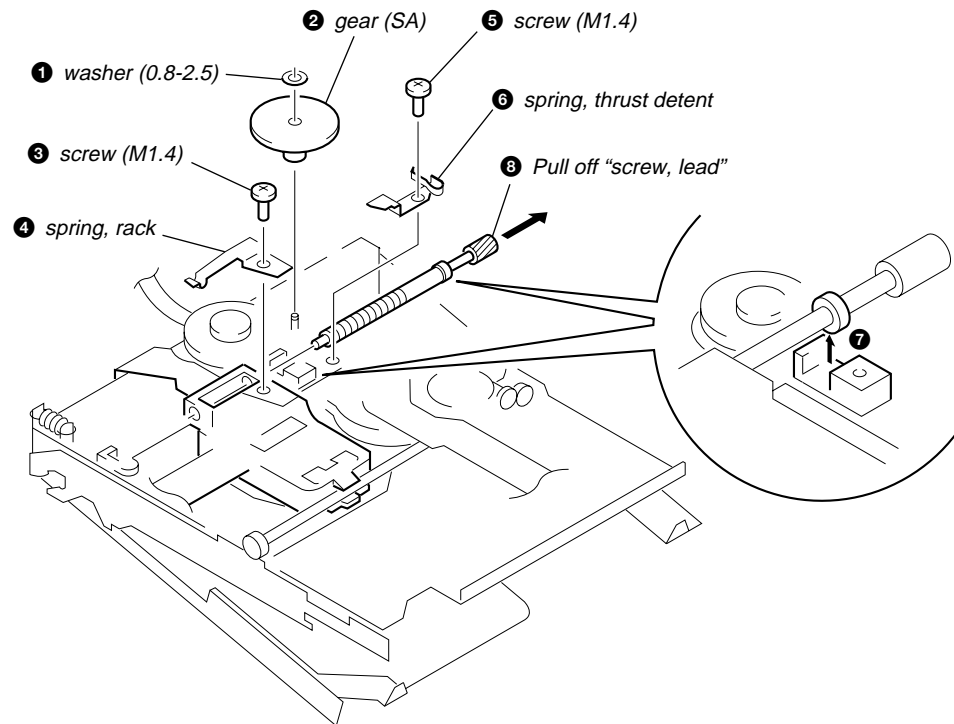

9 Opening the over write head toward the direction **A**, remove the "service assy, OP (LCX-4R)" toward the direction **B**.

Note: Do not open the entire assy forcibly, when opening the over write head.

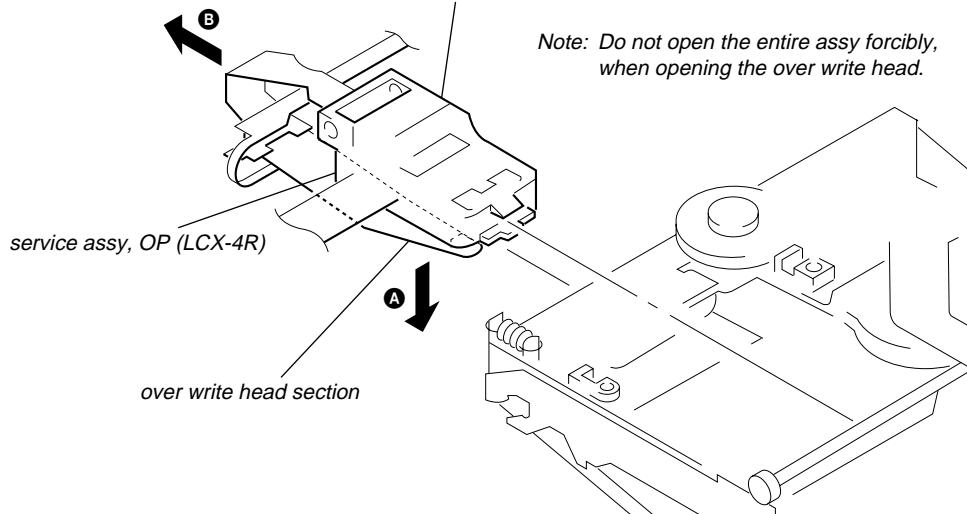

3-10. HOLDER ASSY

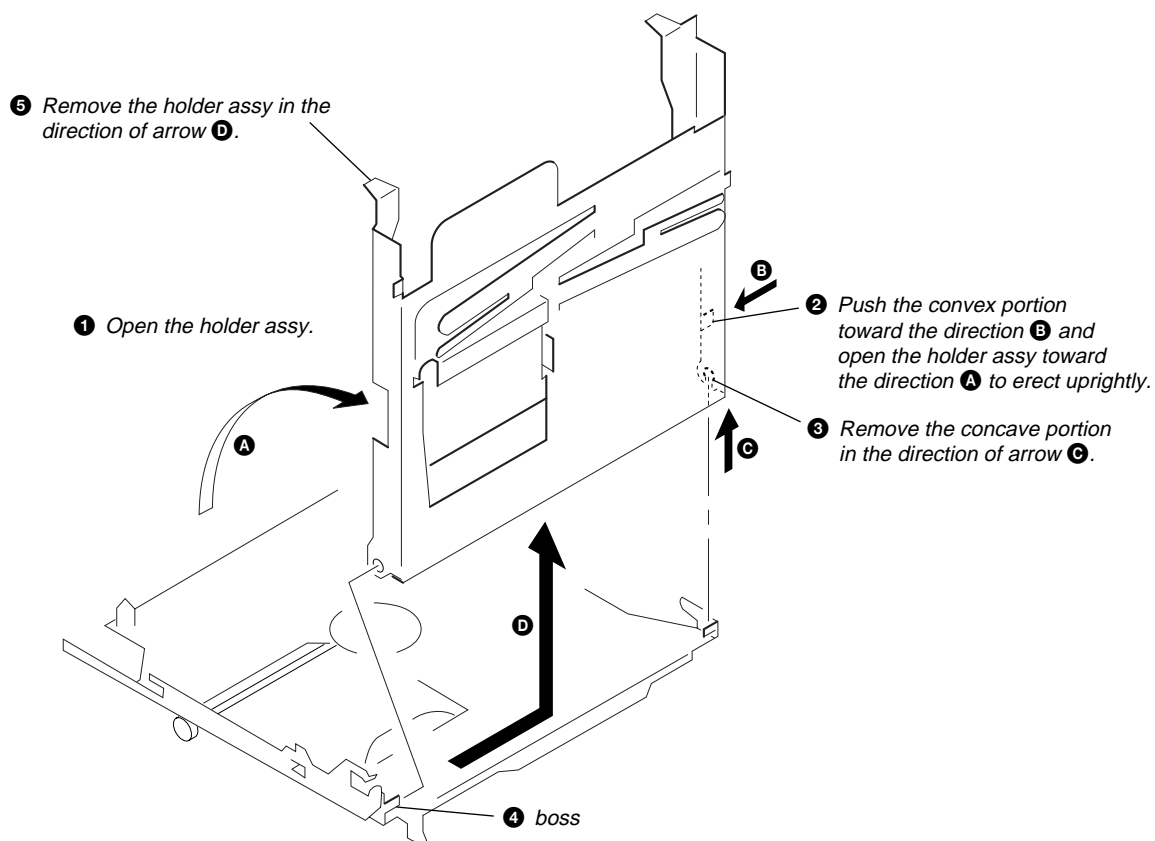

3-11. MOTOR, DC (SLED) (M602)

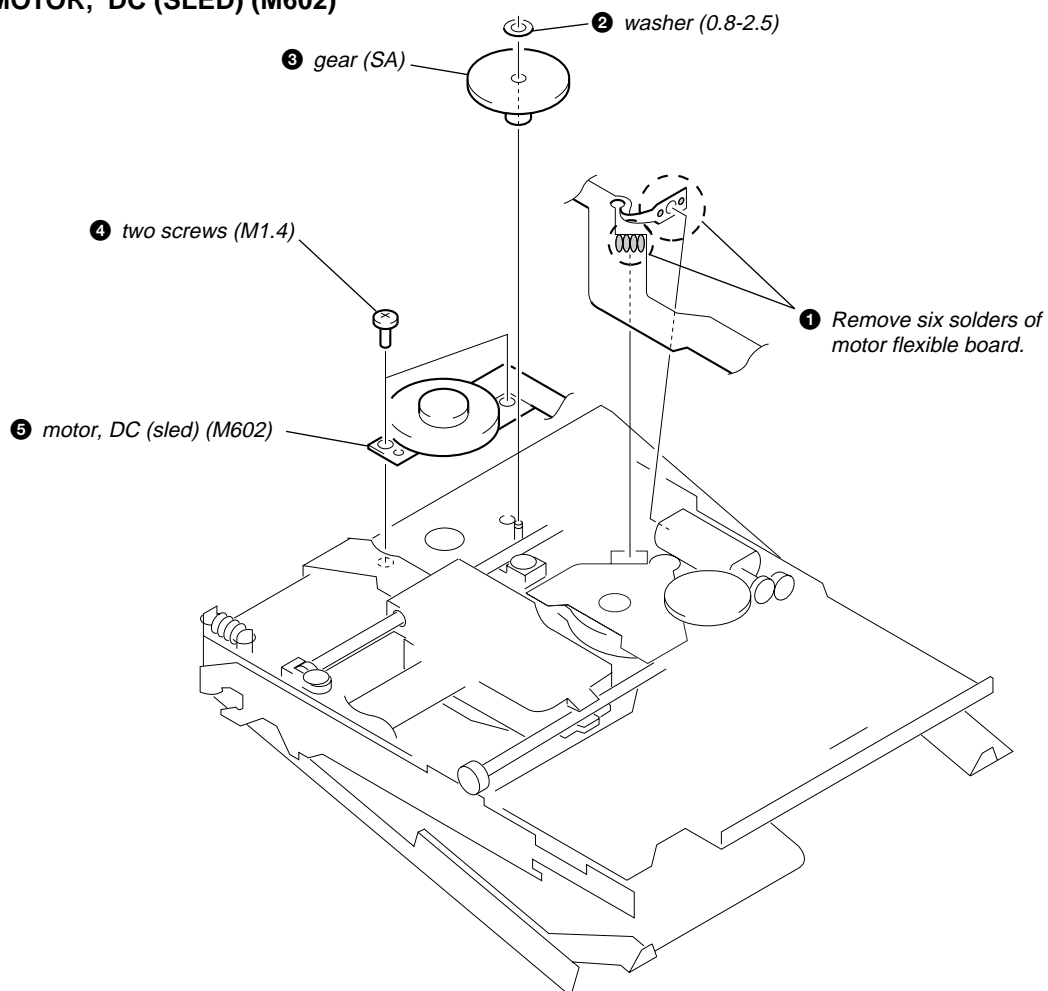

3-12. "MOTOR, DC (SPINDLE) (M601)", "MOTOR, DC (OVER WRITE HEAD UP/DOWN) (M603)"

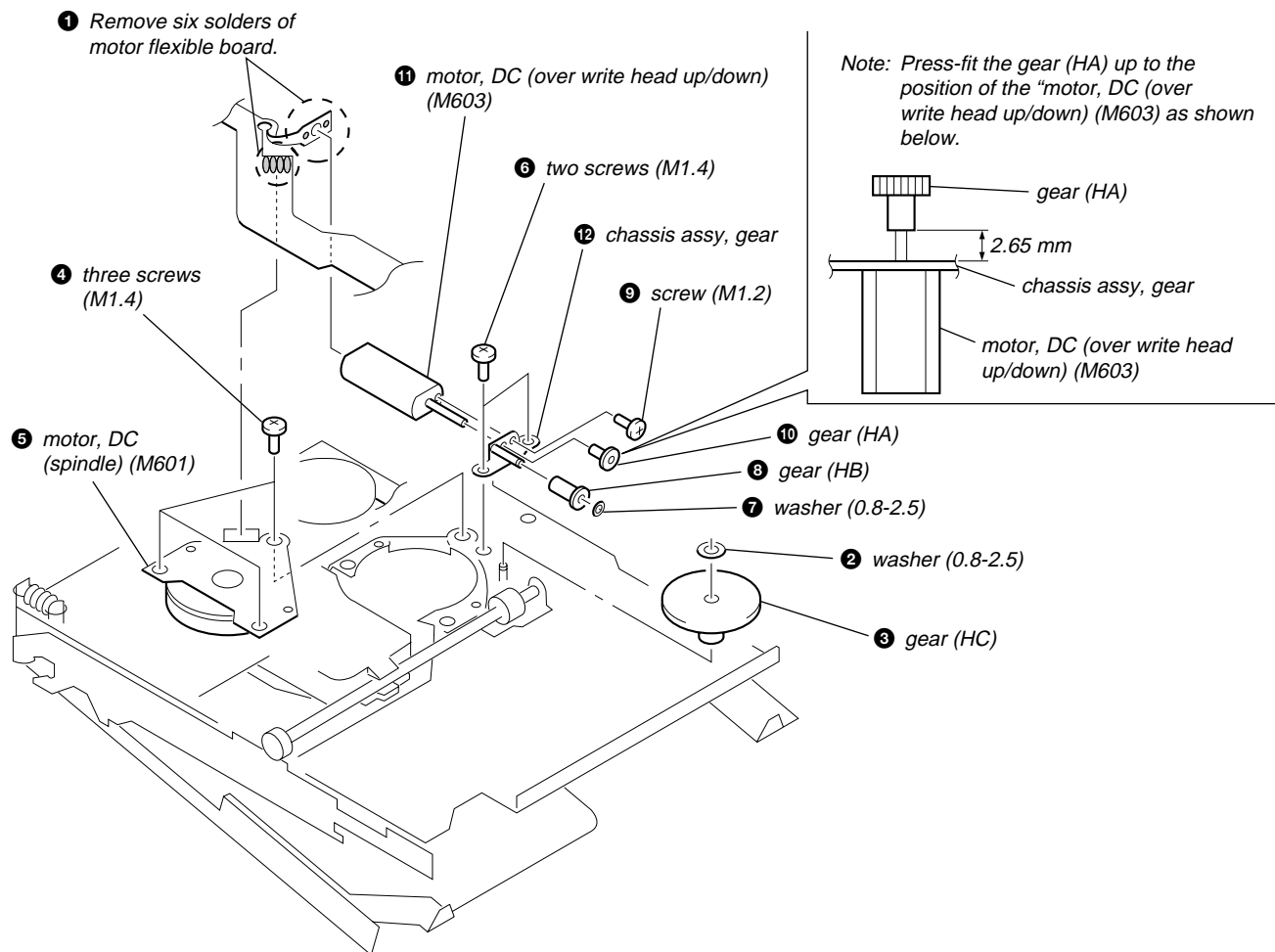

SECTION 4 TEST MODE

Outline

- This set provides the Overall adjustment mode that allows CD and MO discs to be automatically adjusted when in the test mode. In this overall adjustment mode, the disc is discriminate between CD and MO, and each adjustment is automatically executed in order. If a fault is found, the system displays its location. Also, the manual mode allows each individual adjustment to be automatically adjusted.
- Operation in the test mode is performed with the set. A key having no particular description in the text, indicates a set key.
- For the LCD display, the LCD on the remote commander is shown, but the contents of LCD display on the set are same.

Setting Method of Test Mode

There are two different methods to set the test mode:

- ① Short SL801 (TEST) on the MAIN board with a solder bridge (connect pin ③ of IC801 to the ground) and turn on the [HOLD] switch. Then, turn on the power.

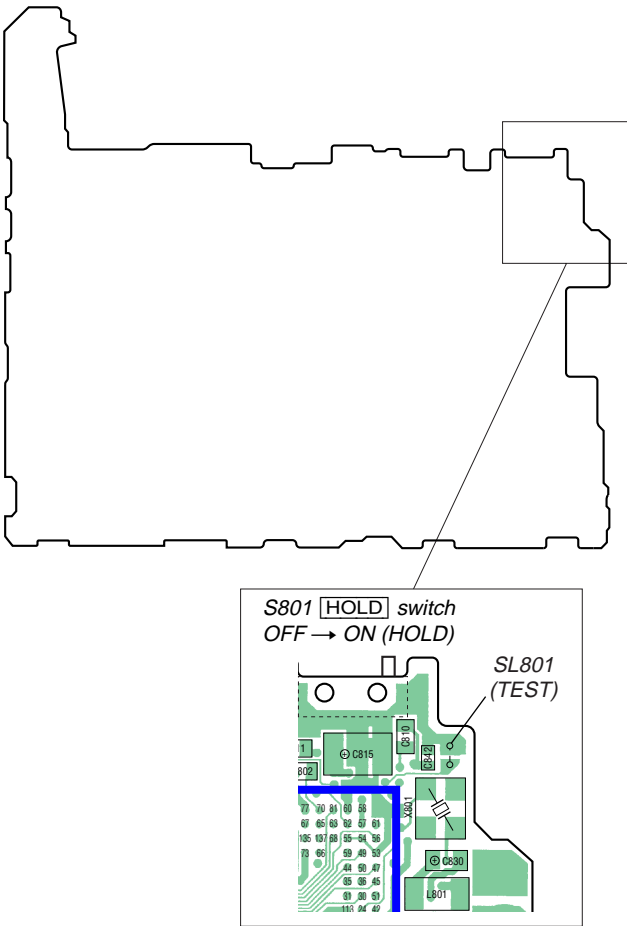

- ② In the normal mode, turn on the [HOLD] switch. While pressing the [VOL-] key press the following order:

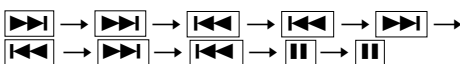

Operation in Setting the Test Mode

- When the test mode becomes active, first the display check mode is selected.
- Other mode can be selected from the display check mode.
- When the test mode is set, the LCD repeats the following display.

Remote commander LCD display

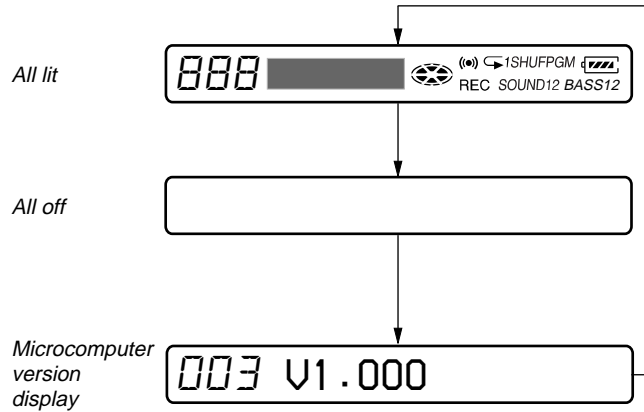

Destination code

- 002 : Except US, Canadian models
- 003 : US, Canadian models

- When the [HOLD] key is pressed and hold down, the display at that time is held so that display can be checked.

Caution: On the set having the microcomputer version 1.000, some adjusted values were set in the manual mode at the shipment, but these data will be cleared when the NV is reset. Therefore, on the set having the microcomputer version 1.000, change the adjusted values following the Change of Adjusted Values immediately after the NV was reset (see page 18).

Releasing the Test Mode

For test mode set with the method ①:

Turn off the power and open the solder bridge on SL801 (TEST) on the MAIN board.

Note: Remove the solders completely. Remaining could be shorted with the chassis, etc.

For test mode set with the method ②:

Turn off the power.

Note: On the set having the microcomputer version 1.000, if electrical adjustment (see page 18) has not been finished completely, always start in the test mode. (The set cannot start in normal mode)
On the set having the microcomputer version 2.000 or later, if electrical adjustment (see page 18) has not been finished completely, "NV Error" is displayed on the LCD.

Configuration of Test Mode

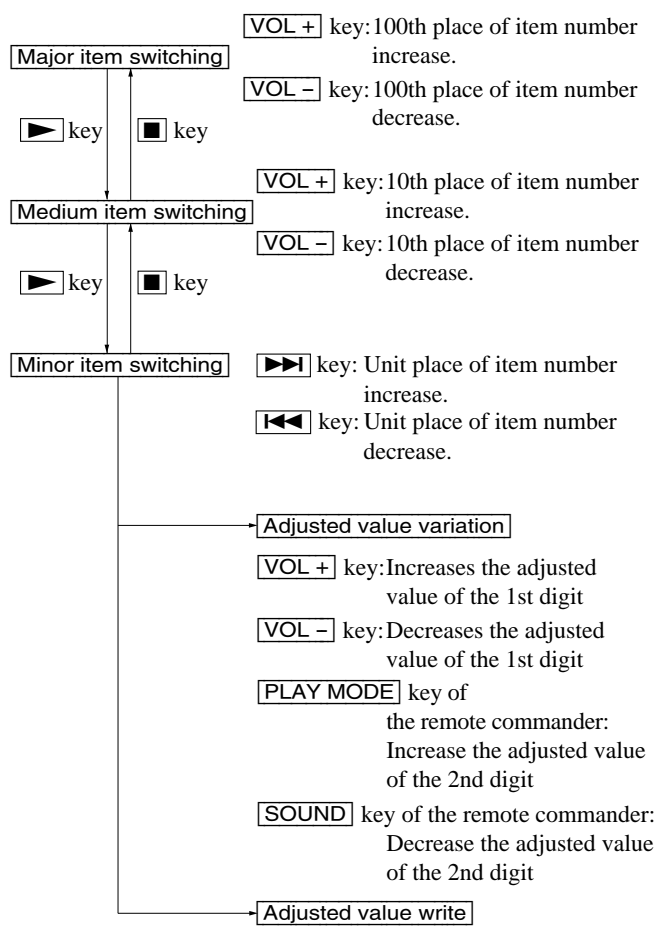
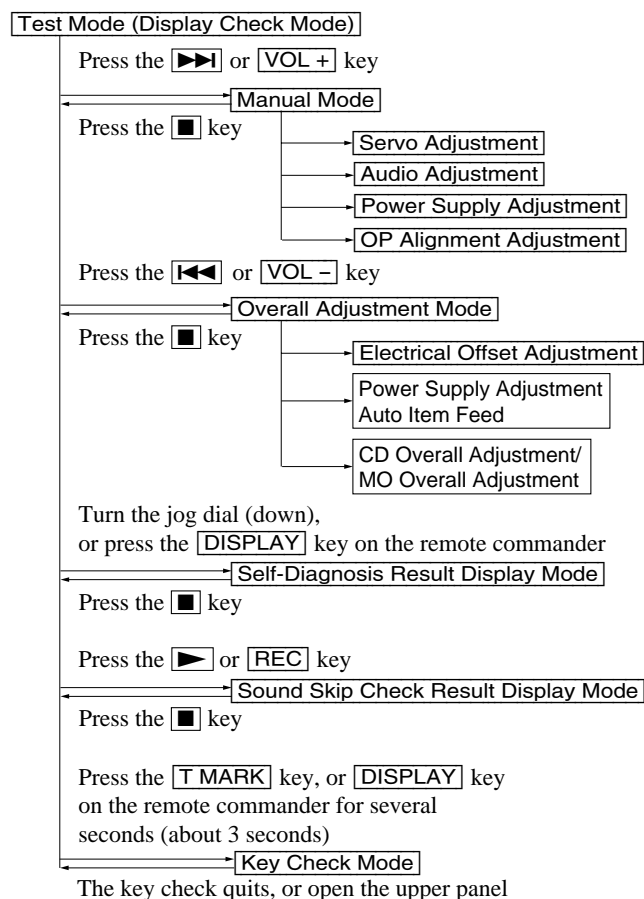

Manual Mode

Mode to adjust or check the operation of the set by function. Normally, the adjustment in this mode is not executed. However, the Manual mode is used to clear the memory, power supply adjustment, and laser power check before performing automatic adjustments in the Overall Adjustment mode.

• Transition method in manual mode

1. Set the test mode (see page 12).
2. Press the or key activates the manual mode where the LCD display as shown below.

Remote commander LCD display

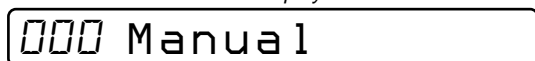

3. During each test, the optical pick-up moves outward or inward while the or key is pressed for several seconds respectively.
4. Each test item is assigned with a 3-digit item number; 100th place is a major item, 10th place is a medium item, and unit place is a minor item. The values adjusted in the test mode are written to the nonvolatile memory (for the items where adjustment was made).

key: When adjusted value is changed: Adjusted value is written. When adjusted value is not changed: That item is adjusted automatically.

- The display changes as shown below each time the jog dial (down) is turned or the **[DISPLAY]** key on the remote commander is pressed.

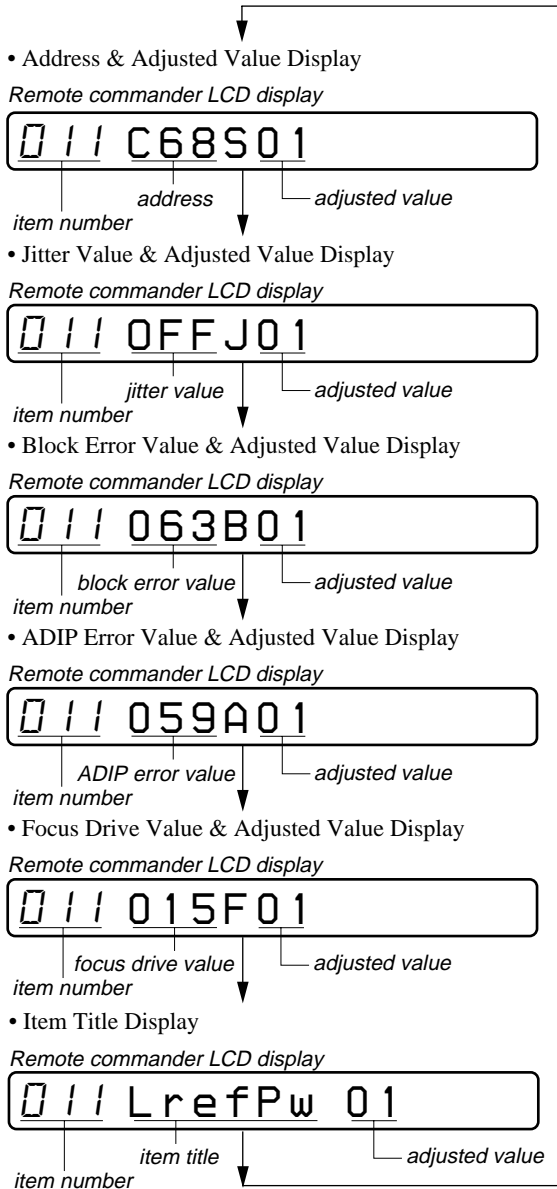

However in the power mode (item number 700's), only the item is displayed.

- Quit the manual mode, and press the **[STOP]** key to return to the test mode (display check mode).

Overall Adjustment Mode

Mode to adjust the servo automatically in all items. Normally, automatic adjustment is executed in this mode at the repair. For further information, refer to “Section 5 Electrical Adjustments” (see page 18).

Self-Diagnosis Result Display Mode

This set uses the self-diagnostic function system in which if an error occurred during the recording or playing, the mechanism control block and the power supply control block in the microcomputer detect it and record its cause as history in the nonvolatile memory.

By checking this history in the test mode, you can analyze a fault and determine its location.

Total recording time is recorded as a guideline of how long the optical pickup has been used, and by comparing it with the total recording time at the time when an error occurred in the self-diagnosis result display mode, you can determine when the error occurred.

Clear both self-diagnosis history data and total recording time, if the optical pickup was replaced.

• **Self-diagnosis result display mode setting method**

- Set the test mode (see page 12).
- In the display check mode, turn the jog dial (down) or press the **[DISPLAY]** key on the remote commander activates the self-diagnosis result display mode where the LCD display as shown below.

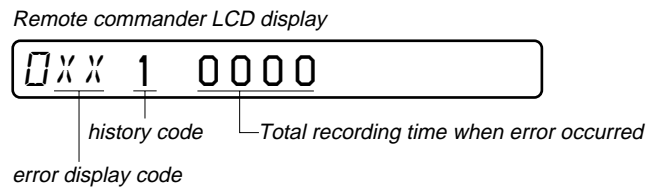

- Then, each time the **[▶▶]** key is pressed, LCD display descends by one as shown below. Also, the LCD display ascends by one when the **[◀◀]** key is pressed.

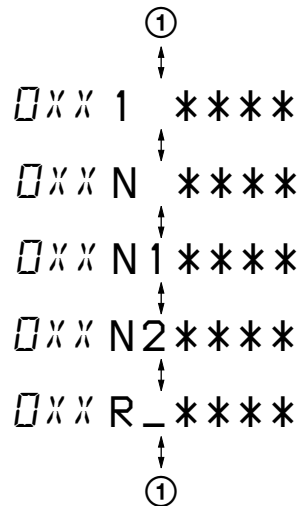

XX : Error code
**** : Total recording time

If the jog dial (down) is turned or the **[DISPLAY]** key on remote commander is pressed with this display, the LCD switches to the simple display mode.

- Quit the self-diagnosis result display mode, and press the **[STOP]** key to return to the test mode (display check mode).

• Description of error indication codes

Problem	Indication code	Meaning of code	Simple display	Description
No error	00	No error	---	No error
Servo system error	01	Illegal access target address was specified	Adrs	Attempt to access an abnormal address
	02	High temperature	Temp	High temperature detected
	03	Focus error	Fcus	Disordered focus or can not read an address
	04	Spindle error	Spdl	Abnormal rotation of disc
TOC error	11	TOC error	TOC	Faulty TOC contents
	12	Data reading error	Data	Data could not be read at SYNC
Power supply system error	22	Low battery	LBat	Momentary interruption detected
Offset system error	31	Offset error	Ofst	Offset error
	32	Focus error ABCD offset error	ABCD	Focus error ABCD offset error
	33	Tracking error Offset error	TE	Tracking error Offset error
	34	X1 tracking error Offset error	X1TE	X1 tracking error Offset error

• Description of indication history

History code number	Description
1	The first error
N	The last error
N1	One error before the last.
N2	Two errors before the last.
R_	Total recording time

Reset the Error Display Code

After servicing, reset the error display code.

• Setting method of reset the error display code

1. Set the test mode (see page 12).
2. Turn the jog dial (down) or press the **[DISPLAY]** key on the remote commander activates the self-diagnosis result display mode.
3. To reset the error display code, press the **[II]** key (twice) when the code is displayed (except "R_***").
(All the data on the 1, N, N1, and N2 will be reset)

Sound Skip Check Result Display Mode

This set can display the count of errors that occurred during the recording/playing for checking.

• Setting method of sound skip check result display mode

1. Set the test mode (see page 12).
2. Press the **▶** key or **REC** key, and the playing or recording sound skip result display mode becomes active respectively where the LCD displays the following.

Remote commander LCD display

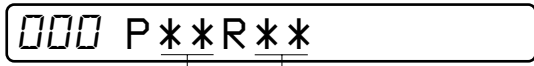

Total count of play system errors (hex.)
Total count of record system errors (hex.)

3. When the **▶** key is pressed, total error count is displayed on the LCD, and each time the **▶▶** key is pressed, the display item moves down by one as shown below. Also, if the **◀◀** key is pressed, the display item moves up by one, then if the **REC** key is pressed, the display in the record mode appears. When the **REC** key is pressed, total error count is displayed on the LCD, and each time the **▶▶** key is pressed, the display item moves down by one as shown below. Also, if the **◀◀** key is pressed, the display item moves up by one, then if the **▶** key is pressed, the display in the play mode appears.

Playing sound skip result display

Recording sound skip result display

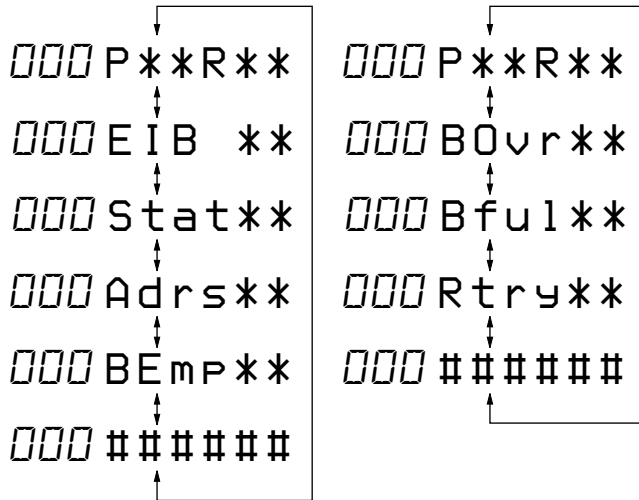

P**R**: Total play/record errors (hex.)
** : Counter of sound skip check each item (hex.)
#####: 6-digit address where sound was skipped last (hex.)

• Cause of sound skip error

	Cause of error	Description of error
Play	EIB	Sound error correction error
	Stat	Decoder status error
	Adrs	Address access error
	BEmp	Buffer is empty
Record	BOvr	Buffer is full, and sounds were dumped
	Bful	Buffer capacity becomes less, and forcible writing occurred
	Rtry	Retry times over

4. To quit the sound skip check result display mode and to return to the test mode (display check mode), press the **■** key.

Jog and Key Check Mode

This set can check if the set and remote commander function normally.

• Setting method of jog check mode

1. Set the test mode (see page 12).
2. Press the jog button to activate the jog check mode and display as below.

Remote commander LCD display



3. Turn the jog dial downwards one click.

Remote commander LCD display

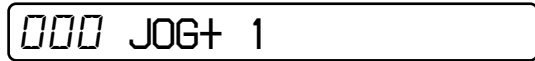

4. Turn the jog dial downwards three more clicks.

Remote commander LCD display



5. Turn the jog dial upwards one click.

Remote commander LCD display

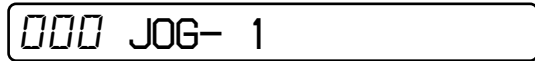

6. Turn the jog dial upwards three more clicks.

Remote commander LCD display



7. When the **■** key is pressed, it changes over to the key check mode.

Note: To enter the key check mode, it is not necessary to enter via the jog dial check mode. (Refer to next item)

• Setting method of key check mode

1. Set the test mode (see page 12).
2. Press the **T MARK** key or **DISPLAY** key on the remote commander for several seconds (about 3 seconds) activates the key check mode. (At the last two digits, AD value of remote commander key line is displayed in hexadecimal)

Remote commander LCD display

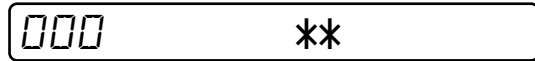

** : AD value of the remote commander key (hexadecimal 00 to FF)

3. When each key on the set and on remote commander is pressed, its name is displayed on the remote commander LCD. (The operated position is displayed for 4 seconds after the slide switch is operated. If any other key is pressed during this display, the remote commander LCD switches to its name display)

Example1: When the  key on the set is pressed:

Remote commander LCD display

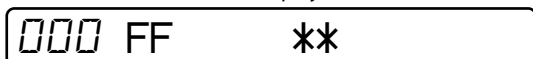

** : AD value of the remote commander key (hexadecimal 00 to FF)

Example2: When the  key on the remote commander is pressed:

Remote commander LCD display

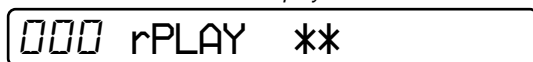

** : AD value of the remote commander key (hexadecimal 00 to FF)

4. When all the keys on the set and on the remote commander are considered as OK, the following displays are shown for 4 seconds.

Example1: When the keys on the set are considered as OK:

Remote commander LCD display

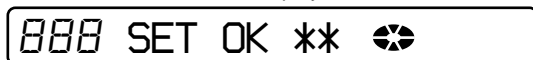

** : AD value of the remote commander key (hexadecimal 00 to FF)

Example2: When the keys on the remote commander are considered as OK:

Remote commander LCD display



** : AD value of the remote commander key (hexadecimal 00 to FF)

5. When all keys were checked or if the upper panel is opened, the key check mode quits and the test mode (display check mode) comes back.

SECTION 5 ELECTRICAL ADJUSTMENTS

Outline

- In this set, automatic adjustment of CD and MO can be performed by entering the test mode (see page 12). However, before starting automatic adjustment, the memory clear, power supply adjustment, and laser power check must be performed in the manual mode.
- A key having no particular description in the text, indicates a set key.
- For the LCD display, the LCD on the remote commander is shown, but the contents of LCD display on the set are same.

Precautions for Adjustment

- Adjustment must be done in the test mode only. After adjusting, release the test mode.
- Use the following tools and measuring instruments.
 - Test CD disc TDYS-1 (Part No. : 4-963-646-01)
 - SONY MO disc available on the market
 - Digital voltmeter
 - Laser power meter LPM-8001 (Part No. : J-2501-046-A)
 - Thermometer (using the Temperature Correction)
- Unless specified otherwise, supply DC 3V from the DC IN 3V jack (J601).
- Switch position
HOLD switch ON

Adjustment Sequence

- | | | | | |
|---|---|--|--|---|
| 1. NV Reset (EEPROM clear) | ↓ | | | |
| 2. Power Supply Manual Adjustment | ↓ | | | } |
| 3. Temperature Correction (item number: 014) | ↓ | | | |
| 4. Laser Power Check | ↓ | | | } |
| 5. Electrical Offset Adjustment | ↓ | | | |
| Caution: This adjustment must be made with no disc loaded. | | | | |
| 6. CD Overall Adjustment | ↓ | | | } |
| 7. MO Overall Adjustment | ↓ | | | |
| 8. RESUME Clear | ↓ | | | } |
| | | | | |

NV Reset

Caution: The shipment data will be cleared when the NV is reset. Therefore, change the adjusted values following the Change of Adjusted Values immediately after the NV was reset.

Setting method of NV reset

- Select the manual mode of the test mode, and set item number 021 NV Reset (see page 13).

Remote commander LCD display



- Press the **[]** key.

Remote commander LCD display

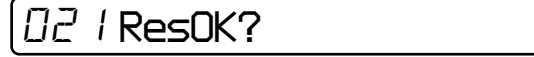

- Press the **[]** key once more.

Remote commander LCD display



↓ NV reset (after several seconds)

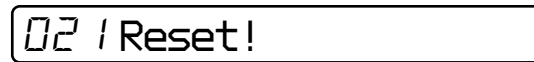

- Press the **[]** key to quit the manual mode, and return the test mode (display check mode).

Change of adjusted values

In this set, some adjusted values were set in the manual mode at the shipment, but these data will be cleared when the NV is reset. Therefore, modify the adjusted values through the following procedure immediately after the NV was reset.

- Item numbers in which the adjusted values are to be modified
 - Item number 861
 - Item number 862
 - Item number 863
 - Item number 864
 - Item number 865
 - Item number 866

Adjusted values modifying procedure

- Select the manual mode of the test mode, and set item number 861 (see page 13).

Remote commander LCD display

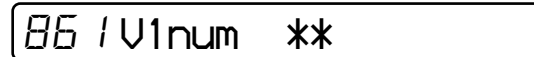

** : Adjusted value

- Adjust with the **[VOL+]** key (adjusted value up) or **[VOL-]** key (adjusted value down) so that the adjusted value becomes 0F.
- Press the **[]** key to write the adjusted value.
- Select the manual mode of the test mode, and set item number 862 (see page 13).

Remote commander LCD display

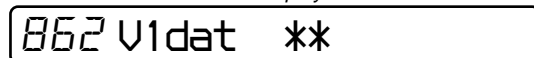

** : Adjusted value

- Adjust with the **[VOL+]** key (adjusted value up) or **[VOL-]** key (adjusted value down) so that the adjusted value becomes 0B.
- Press the **[]** key to write the adjusted value.

- 7) Select the manual mode of the test mode, and set item number 863 (see page 13).

Remote commander LCD display

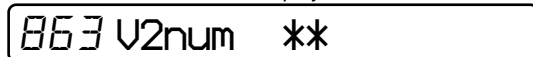

** : Adjusted value

- 8) Adjust with the [VOL+] key (adjusted value up) or [VOL-] key (adjusted value down) so that the adjusted value becomes 87.
- 9) Press the [] key to write the adjusted value.
- 10) Select the manual mode of the test mode, and set item number 864 (see page 13).

Remote commander LCD display

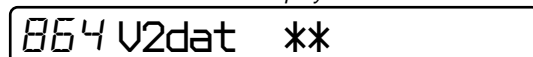

** : Adjusted value

- 11) Adjust with the [VOL+] key (adjusted value up) or [VOL-] key (adjusted value down) so that the adjusted value becomes 39.
- 12) Press the [] key to write the adjusted value.
- 13) Select the manual mode of the test mode, and set item number 865 (see page 13).

Remote commander LCD display

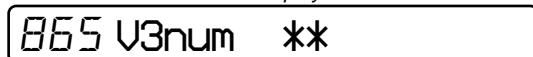

** : Adjusted value

- 14) Adjust with the [VOL+] key (adjusted value up) or [VOL-] key (adjusted value down) so that the adjusted value becomes 23.
- 15) Press the [] key to write the adjusted value.
- 16) Select the manual mode of the test mode, and set item number 866 (see page 13).

Remote commander LCD display

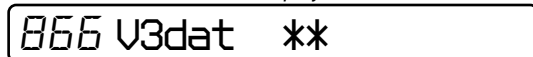

** : Adjusted value

- 17) Adjust with the [VOL+] key (adjusted value up) or [VOL-] key (adjusted value down) so that the adjusted value becomes EC.
- 18) Press the [] key to write the adjusted value.

Power Supply Manual Adjustment

• Adjustment sequence

Adjustment must be done with the following steps.

1. Vc PWM Duty (L) adjustment (item number: 762)
- ↓
2. Vc PWM Duty (H) adjustment (item number: 763)
- ↓
3. VI PWM Duty adjustment (item number: 764)

• Setting method of power supply manual adjustment

1. Make sure that the power supply voltage is 3V.
2. Set the test mode (see page 12).
3. Press the [] or [VOL-] key to activate the overall adjustment mode.

Remote commander LCD display

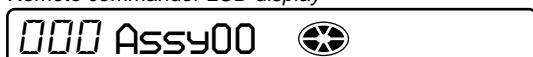

4. Turn the jog dial (up), or press the [PLAYMODE] key on the remote commander.
(Turning the jog dial (up), or pressing the [PLAYMODE] key on the remote commander causes the item number to be switched to 762)

• Adjustment method of Vc PWM Duty (L) (item number: 762)

Remote commander LCD display

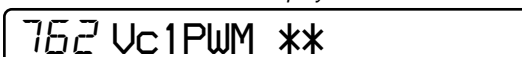

** : Adjusted value

1. Connect a digital voltmeter to the AP914 (VC) on the MAIN board, and adjust [VOL +] key (voltage up) or [VOL -] key (voltage down) so that the voltage becomes 2.40 ± 0.005 V.

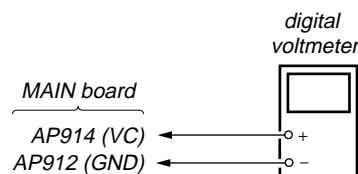

2. Press the [] key to write the adjusted value.
(The item number changes to 763 when [] key is pressed)

Adjustment and Connection Location: MAIN board
(see page 20)

• Adjustment method of Vc PWM Duty (H) (item number: 763)

Remote commander LCD display

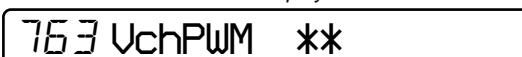

** : Adjusted value

1. Connect a digital voltmeter to the AP914 (VC) on the MAIN board, and adjust [VOL +] key (voltage up) or [VOL -] key (voltage down) so that the voltage becomes 2.75 ± 0.015 V.

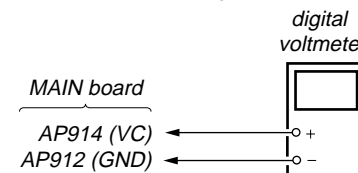

2. Press the [] key to write the adjusted value.
(The item number changes to 764 when [] key is pressed)

Adjustment and Connection Location: MAIN board
(see page 20)

• Adjustment method of VI PWM Duty (item number: 764)

Remote commander LCD display

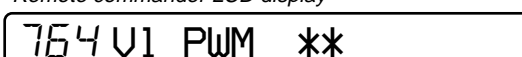

** : Adjusted value

1. Connect a digital voltmeter to the AP915 (VL) on the MAIN board, and adjust [VOL +] key (voltage up) or [VOL -] key (voltage down) so that the voltage becomes 2.30 ± 0.005 V.

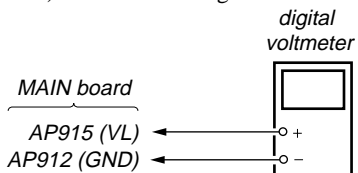

- When press the key to write the adjusted value, LCD displays as follows and power supply manual adjustment has completed.

Remote commander LCD display



Adjustment and Connection Location: MAIN board

Temperature Correction

• **Adjustment method of temperature correction**

- Select the manual mode of test mode, and set the mode number 014 (see page 13).

Remote commander LCD display

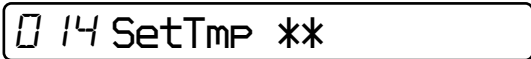

** : Adjusted value

- Measure the ambient temperature.
- Adjust with , key so that the adjusted value (hexadecimal value) becomes the ambient temperature. (Initial value: 14h = 20 °C, Adjusting range: 80h to 7fh (-128 °C to +127 °C))
- Press the key to write the adjusted value.

Laser Power Check

Connection :

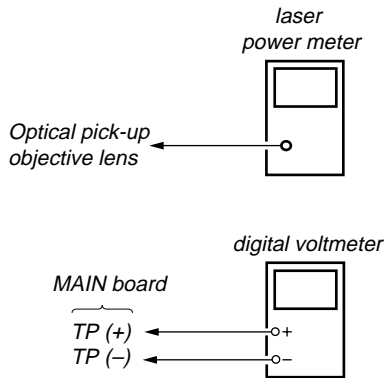

Checking Method :

- Select the manual mode of test mode (see page 13), and set the laser power adjusting mode (item number 010).

Remote commander LCD display

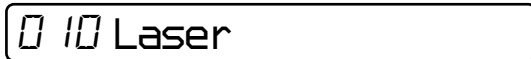

- Press the key continuously until the optical pick-up moves to the most inward track.
- Open the cover and set the laser power meter on the objective lens of the optical pick-up.
- Press the key, and set the laser MO read adjustment mode (item number 011).

Remote commander LCD display

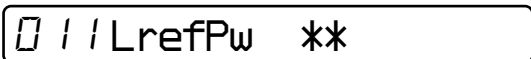

- Check that the laser power meter reading is 0.81 ± 0.08 mW.
- Check that the voltage both ends (TP (+) and TP (-)) of resistor R521 at this time is below 44 mV.

- Press the key, and set the laser CD read adjustment mode (item number 012).

Remote commander LCD display



- Check that the laser power meter reading is 0.97 ± 0.10 mW.
- Check that the voltage both ends (TP (+) and TP (-)) of resistor R521 at this time is below 44 mV.
- Press the key, and set the laser MO write adjustment mode (item number 013).

Remote commander LCD display



- Check that the laser power meter reading is 4.95 ± 0.50 mW.
- Check that the voltage both ends (TP (+) and TP (-)) of resistor R521 at this time is below 80 mV.
- Press the key to quit the manual mode, and activate the test mode (display check mode).

Checking and Connection Location: MAIN board

Adjustment/checking and Connection Location:

- MAIN Board (Conductor side) -

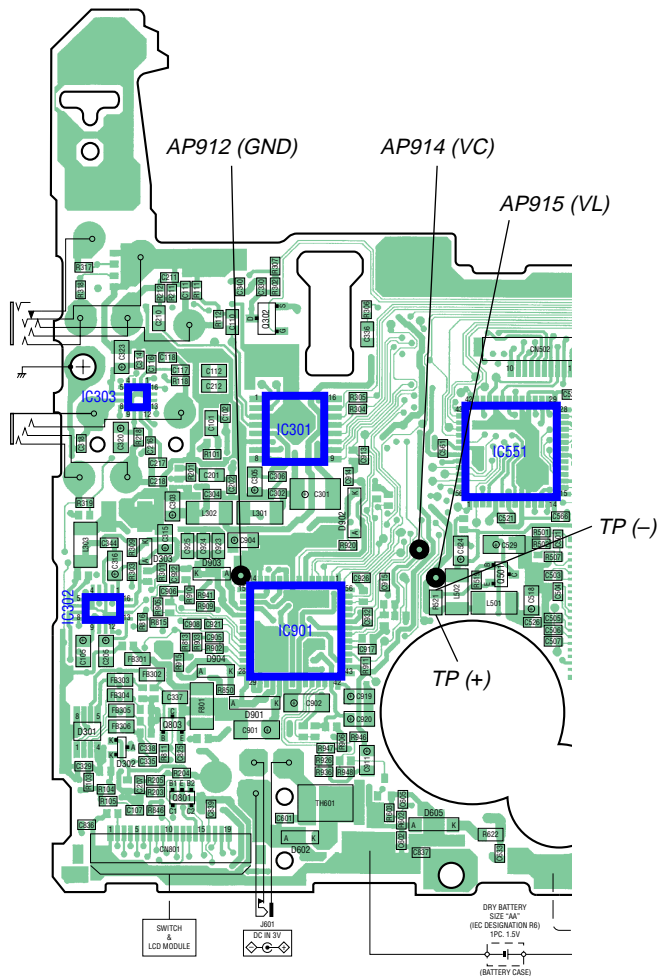

Overall Adjustment Mode

• Configuration of overall adjustment

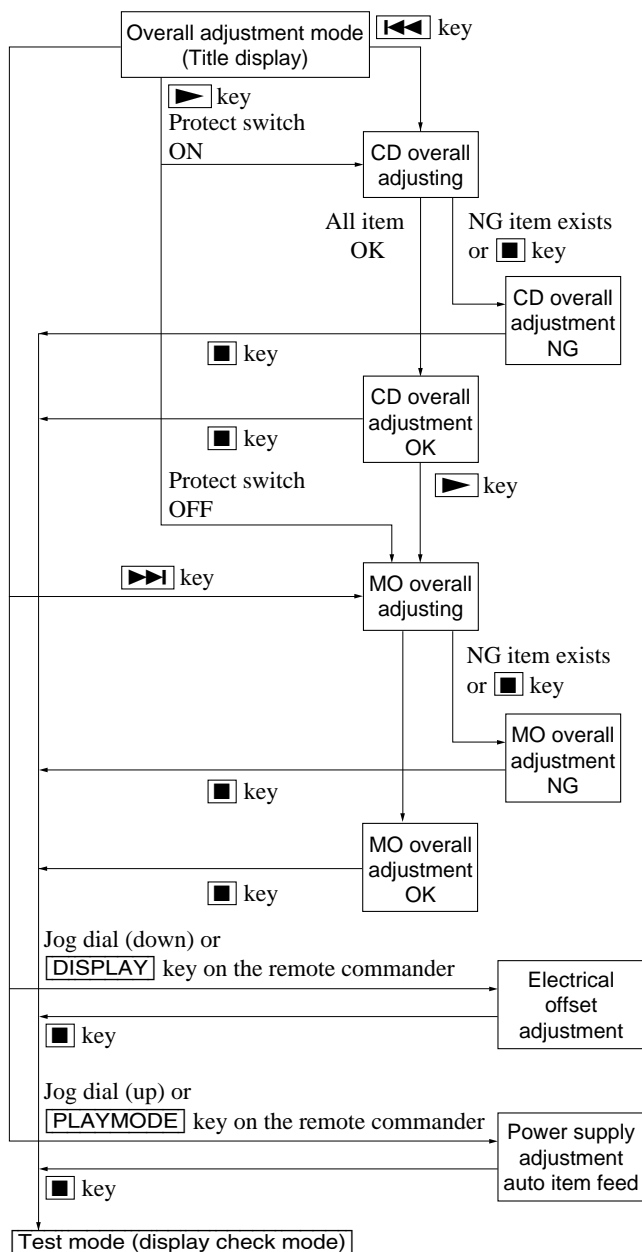

Note: Adjust the CD first, when performing adjustment.

• Overall adjustment mode (title display)

Remote commander LCD display

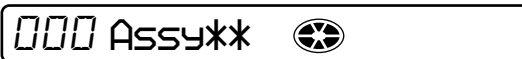

⊗: (Disc mark) At end of power supply adjustment: Outside lit
At end of electrical offset adj.: Inside lit

Note: On the set having microcomputer version 1.000, the disc mark is displayed on the remote commander LCD only.

** : Left side = MO overall adjustment information

F* : MO overall adjustment completed

1* : Manual adjustment exists (overall adj. not completed)

0* : Not adjusted

Right side = CD overall adjustment information

F* : CD overall adjustment completed

1* : Manual adjustment exists (overall adj. not completed)

0* : Not adjusted

• Electrical offset adjusting method

Caution: The electrical offset adjustment must be made with no disc loaded.

1. Make sure that the power supply voltage is 3 V.
2. Set the test mode (see page 12).
3. Press the [Left Arrow] or [VOL-] key to activate the overall adjustment mode.

Remote commander LCD display

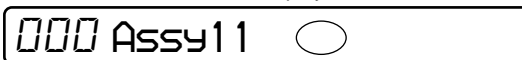

4. Turn the jog dial (down), or press the [DISPLAY] key on the remote commander.

Remote commander LCD display

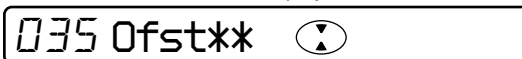

5. Electrical offset adjustment is over, if the following display appears.

Remote commander LCD display

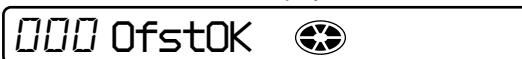

• **Adjustment method of overall CD and MO adjustment mode**

1. Set the test mode (see page 12).
2. Press the **[◀◀]** or **[VOL -]** key to activate the overall adjustment mode.

Remote commander LCD display

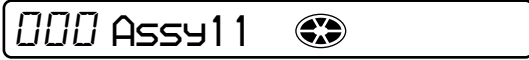

3. Insert CD disc in the set, and press the **[◀◀]** key to set the Overall CD Adjustment mode. Automatic adjustments are made.

Remote commander LCD display



***: Item number for which an adjustment is being executed.

4. In case of CD overall adjustment NG, reset the NV (see page 18), then readjust from the temperature correction (see page 20).

Remote commander LCD display



***: NG item number.

5. If OK through the overall CD adjustments, then perform overall MO adjustments.

Remote commander LCD display

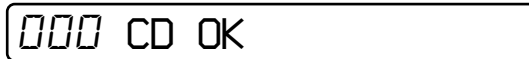

6. Insert MO disc in the set, and press the **[▶▶]** key to set the Overall MO Adjustment mode. Automatic adjustments are made.

Remote commander LCD display



***: Item number for which an adjustment is being executed.

7. In case of MO overall adjustment NG, reset the NV (see page 18), then readjust from the temperature correction (see page 20).

Remote commander LCD display



***: NG item number.

8. If OK through the overall MO adjustments, press the **[■]** key to return to the test mode and terminate the Overall Adjustment mode.

Remote commander LCD display

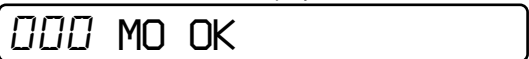

• **Overall CD and MO adjustment items**

1. Overall CD adjustment items

Item No.	Description
312	CD electrical offset adjustment
313	
314	
321	CD tracking error gain adjustment
328	CD TWPP gain adjustment
324	CD tracking error offset adjustment
332	
336	CD ABCD gain adjustment
344	CD focus gain adjustment
345	CD tracking gain adjustment
521	CD two-axis sensitivity adjustment
522	

2. Overall MO adjustment items

Item No.	Description
112	MO electrical offset adjustment
113	
114	
118	
221	Low reflective CD tracking error gain adjustment
224	Low reflective CD tracking error offset adjustment
232	
236	Low reflective CD ABCD level adjustment
244	Low reflective CD focus gain adjustment
245	Low reflective CD tracking gain adjustment
121	MO tracking error gain adjustment
122	MO TON offset adjustment
134	MO TWPP gain adjustment
131	MO triple speed read TWPP offset adjustment
132	
136	MO ABCD gain adjustment
144	MO focus gain adjustment
145	MO tracking gain adjustment
138	MO RF gain adjustment
434	MO write TWPP gain adjustment
431	MO write TWPP offset adjustment
432	MO tracking error offset adjustment
436	MO write ABCD gain adjustment
445	MO write tracking gain adjustment
411	MO normal speed read TWPP offset adjustment
412	MO tracking error offset adjustment
448	20 sec full recording

Resume Clear

Perform the Resume clear when all adjustments completed.

• Resume clear setting method

1. Select the manual mode of the test mode, and set item number 043 (see page 13).

Remote commander LCD display

043 Resume CC

2. Press the **[F1]** key.

Remote commander LCD display

043 Res***

↓ Resume clear complete

043 ResC1r

3. Press the **[F2]** key to return to the test mode (display check mode).

Patch Data Rewriting When Nonvolatile Memory was Replaced

On this set, if the nonvolatile memory was replaced, the modified program data must be written to the nonvolatile memory.

In such a case, write the modified data that meets the microcomputer version following the procedure provided below.

• Modified data writing method (version 1.000)

1. Select the manual mode of the test mode, and set item number 022 (see page 13).

Remote commander LCD display

022 PatC1r CC

2. Press the **[F1]** key to initialize the patch data.
(The modified data writing is over, if the adjusted value changes to DD)

Remote commander LCD display

022 ***SDD

DD: Adjusted value

3. Press the **[▶]** key or **[▶▶]** key to set item number 023.

Remote commander LCD display

023 Patch00

00: Adjusted value

4. Press the **[VOL+]** key once to change the adjusted value to 01.
5. Press the **[DISPLAY]** key on the remote commander for several seconds (about 3 seconds) to activate the patch data write mode.
(The following display will appear where 00 is blinking)

Remote commander LCD display

023 OFF800

00: Adjusted value

6. Adjust with the **[VOL+]** key (adjusted value up) or **[VOL-]** key (adjusted value down) so that the adjusted value becomes 16.

Remote commander LCD display

023 OFF816

16: Adjusted value

7. Press the **[F1]** key.
(OFF8 is blinking)
8. Press the **[VOL+]** key once to change the blinking portion to OFF9.

Remote commander LCD display

023 OFF900

00: Adjusted value

9. Press the **[F2]** key.
(00 is blinking)
10. Adjust with the **[VOL+]** key (adjusted value up) or **[VOL-]** key (adjusted value down) so that the adjusted value becomes 0E.

Remote commander LCD display

023 OFF90E

0E: Adjusted value

11. Press the **[F1]** key.
(OFF9 is blinking)
12. Press the **[VOL+]** key once to change the blinking portion to OFFA.

Remote commander LCD display

023 OFFA00

00: Adjusted value

13. Press the **[F2]** key.
(00 is blinking)
14. Adjust with the **[VOL+]** key (adjusted value up) or **[VOL-]** key (adjusted value down) so that the adjusted value becomes 03.

Remote commander LCD display

023 OFFA03

03: Adjusted value

15. Press the **[F1]** key.
(OFFA is blinking)
16. Press the **[VOL+]** key five times to change the blinking portion to OFFF.

Remote commander LCD display

023 OFFF00

00: Adjusted value

17. Press the **[F2]** key.
(00 is blinking)
18. Adjust with the **[VOL+]** key (adjusted value up) or **[VOL-]** key (adjusted value down) so that the adjusted value becomes DF.

Remote commander LCD display

023 OFFFDF

DF: Adjusted value

19. Press the **[F1]** key.
(OFFF is blinking)
20. Press the **[VOL+]** key once to change the blinking portion to 1000.

Remote commander LCD display

023 100000

00: Adjusted value

21. Press the **[■]** key.
(00 is blinking)
22. Adjust with the **[VOL+]** key (adjusted value up) or **[VOL-]** key (adjusted value down) so that the adjusted value becomes DA.

Remote commander LCD display



DA: Adjusted value

23. Press the **[■]** key.
(1000 is blinking)
24. Press the **[VOL+]** key once to change the blinking portion to 1001.

Remote commander LCD display



00: Adjusted value

25. Press the **[■]** key.
(00 is blinking)
26. Adjust with the **[VOL+]** key (adjusted value up) or **[VOL-]** key (adjusted value down) so that the adjusted value becomes 85.

Remote commander LCD display

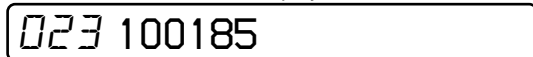

85: Adjusted value

27. Press the **[■]** key.
(1001 is blinking)
28. Press the **[VOL+]** key once to change the blinking portion to 1002.

Remote commander LCD display

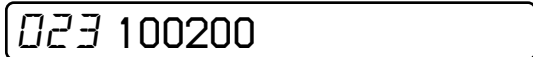

00: Adjusted value

29. Press the **[■]** key.
(00 is blinking)
30. Adjust with the **[VOL+]** key (adjusted value up) or **[VOL-]** key (adjusted value down) so that the adjusted value becomes 02.

Remote commander LCD display

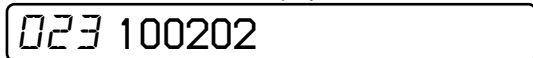

02: Adjusted value

31. Press the **[■]** key.
(1002 is blinking)
32. Press the **[VOL+]** key twice to change the blinking portion to 1004.

Remote commander LCD display

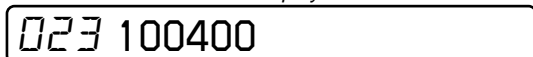

00: Adjusted value

33. Press the **[■]** key.
(00 is blinking)
34. Adjust with the **[VOL+]** key (adjusted value up) or **[VOL-]** key (adjusted value down) so that the adjusted value becomes 02.

Remote commander LCD display

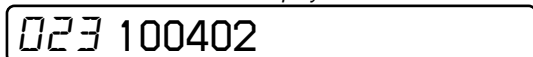

02: Adjusted value

35. Press the **[■]** key.
(1004 is blinking)
36. Press the **[VOL+]** key once to change the blinking portion to 1005.

Remote commander LCD display



00: Adjusted value

37. Press the **[■]** key.
(00 is blinking)
38. Adjust with the **[VOL+]** key (adjusted value up) or **[VOL-]** key (adjusted value down) so that the adjusted value becomes D0.

Remote commander LCD display



D0: Adjusted value

39. Press the **[■]** key.
(1005 is blinking)
40. Press the **[VOL+]** key twice to change the blinking portion to 1007.

Remote commander LCD display

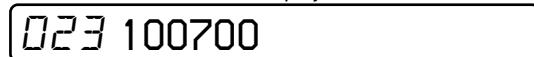

00: Adjusted value

41. Press the **[■]** key.
(00 is blinking)
42. Adjust with the **[VOL+]** key (adjusted value up) or **[VOL-]** key (adjusted value down) so that the adjusted value becomes DF.

Remote commander LCD display



DF: Adjusted value

43. Press the **[■]** key.
(1007 is blinking)
44. Press the **[VOL+]** key to change the blinking portion to 1018, and press the **[DISPLAY]** key on the remote commander for several seconds (about 3 seconds) to exit the patch data write mode and display as below.

Remote commander LCD display

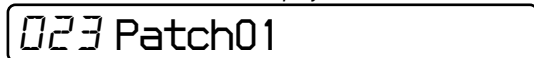

01: Adjusted value

45. Press the **[VOL+]** key to display as below.

Remote commander LCD display

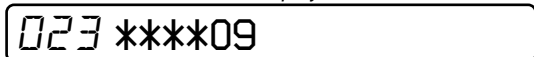

09: Adjusted value

46. Press the **[DISPLAY]** key on the remote commander for several seconds (about 3 seconds) to activate the patch data write mode. (The following display will appear where 00 is blinking)

Remote commander LCD display

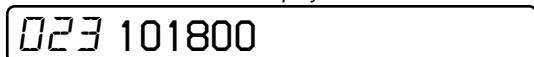

00: Adjusted value

47. Adjust with the **[VOL+]** key (adjusted value up) or **[VOL-]** key (adjusted value down) so that the adjusted value becomes 0A.

Remote commander LCD display

023 10180A

0A: Adjusted value

48. Press the **[II]** key.
(1018 is blinking)
49. Press the **[VOL+]** key once to change the blinking portion to 1019.

Remote commander LCD display

023 101900

00: Adjusted value

50. Press the **[■]** key.
(00 is blinking)
51. Adjust with the **[VOL+]** key (adjusted value up) or **[VOL-]** key (adjusted value down) so that the adjusted value becomes 60.

Remote commander LCD display

023 101960

60: Adjusted value

52. Press the **[II]** key.
(1019 is blinking)
53. Press the **[VOL+]** key once to change the blinking portion to 101A.

Remote commander LCD display

023 101A00

00: Adjusted value

54. Press the **[■]** key.
(00 is blinking)
55. Adjust with the **[VOL+]** key (adjusted value up) or **[VOL-]** key (adjusted value down) so that the adjusted value becomes C7.

Remote commander LCD display

023 101AC7

C7: Adjusted value

56. Press the **[II]** key.
(101A is blinking)
57. Press the **[VOL+]** key once to change the blinking portion to 101B.

Remote commander LCD display

023 101B00

00: Adjusted value

58. Press the **[■]** key.
(00 is blinking)
59. Adjust with the **[VOL+]** key (adjusted value up) or **[VOL-]** key (adjusted value down) so that the adjusted value becomes E5.

Remote commander LCD display

023 101BE5

E5: Adjusted value

60. Press the **[II]** key.
(101B is blinking)

61. Press the **[VOL+]** key once to change the blinking portion to 101C.

Remote commander LCD display

023 101C00

00: Adjusted value

62. Press the **[■]** key.
(00 is blinking)
63. Adjust with the **[VOL+]** key (adjusted value up) or **[VOL-]** key (adjusted value down) so that the adjusted value becomes 04.

Remote commander LCD display

023 101C04

04: Adjusted value

64. Press the **[II]** key.
(101C is blinking)
65. Press the **[VOL+]** key twice to change the blinking portion to 101E.

Remote commander LCD display

023 101E00

00: Adjusted value

66. Press the **[■]** key.
(00 is blinking)
67. Adjust with the **[VOL+]** key (adjusted value up) or **[VOL-]** key (adjusted value down) so that the adjusted value becomes A0.

Remote commander LCD display

023 101EA0

A0: Adjusted value

68. Press the **[II]** key.
(101E is blinking)
69. Press the **[VOL+]** key once to change the blinking portion to 101F.

Remote commander LCD display

023 101F00

00: Adjusted value

70. Press the **[■]** key.
(00 is blinking)
71. Adjust with the **[VOL+]** key (adjusted value up) or **[VOL-]** key (adjusted value down) so that the adjusted value becomes E1.

Remote commander LCD display

023 101FE1

E1: Adjusted value

72. Press the **[II]** key.
(101F is blinking)
73. Press the **[VOL+]** key once to change the blinking portion to 1020.

Remote commander LCD display

023 102000

00: Adjusted value

74. Press the **[■]** key.
(00 is blinking)

75. Adjust with the **[VOL+]** key (adjusted value up) or **[VOL-]** key (adjusted value down) so that the adjusted value becomes 0E.

Remote commander LCD display



0E: Adjusted value

76. Press the **[■]** key.
(1020 is blinking)
77. Press the **[VOL+]** key once to change the blinking portion to 1021.

Remote commander LCD display



00: Adjusted value

78. Press the **[■]** key.
(00 is blinking)
79. Adjust with the **[VOL+]** key (adjusted value up) or **[VOL-]** key (adjusted value down) so that the adjusted value becomes F0.

Remote commander LCD display

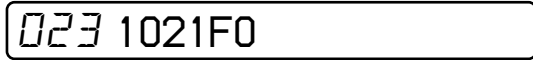

F0: Adjusted value

80. Press the **[■]** key.
(1021 is blinking)
81. Press the **[VOL+]** key once to change the blinking portion to 1022.

Remote commander LCD display

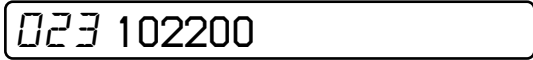

00: Adjusted value

82. Press the **[■]** key.
(00 is blinking)
83. Adjust with the **[VOL+]** key (adjusted value up) or **[VOL-]** key (adjusted value down) so that the adjusted value becomes B0.

Remote commander LCD display

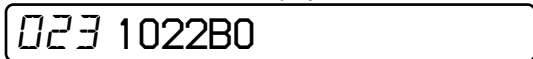

B0: Adjusted value

84. Press the **[■]** key.
(1022 is blinking)
85. Press the **[VOL+]** key once to change the blinking portion to 1023.

Remote commander LCD display

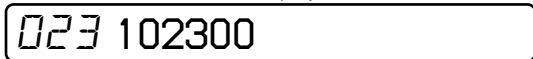

00: Adjusted value

86. Press the **[■]** key.
(00 is blinking)
87. Adjust with the **[VOL+]** key (adjusted value up) or **[VOL-]** key (adjusted value down) so that the adjusted value becomes E1.

Remote commander LCD display

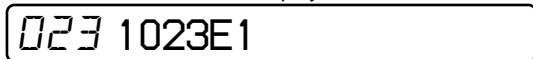

E1: Adjusted value

88. Press the **[■]** key.
(1023 is blinking)

89. Press the **[VOL+]** key to change the blinking portion to 102C, and press the **[DISPLAY]** key on the remote commander for several seconds (about 3 seconds) to exit the patch data write mode and display as below.

Remote commander LCD display

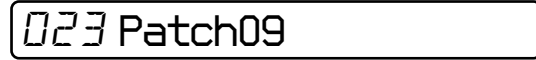

09: Adjusted value

90. Press the **[VOL+]** key to display as below.

Remote commander LCD display



0A: Adjusted value

91. Press the **[DISPLAY]** key on the remote commander for several seconds (about 3 seconds) to activate the patch data write mode. (The following display will appear where 00 is blinking)

Remote commander LCD display

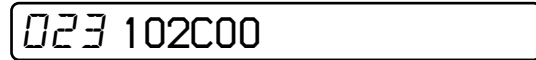

00: Adjusted value

92. Adjust with the **[VOL+]** key (adjusted value up) or **[VOL-]** key (adjusted value down) so that the adjusted value becomes 10.

Remote commander LCD display

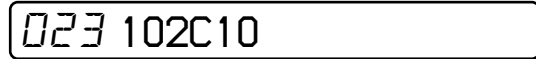

10: Adjusted value

93. Press the **[■]** key.
(102C is blinking)
94. Press the **[VOL+]** key twice to change the blinking portion to 102E.

Remote commander LCD display

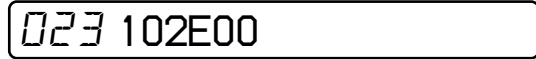

00: Adjusted value

95. Press the **[■]** key.
(00 is blinking)
96. Adjust with the **[VOL+]** key (adjusted value up) or **[VOL-]** key (adjusted value down) so that the adjusted value becomes 9F.

Remote commander LCD display



9F: Adjusted value

97. Press the **[■]** key.
(102E is blinking)
98. Press the **[VOL+]** key once to change the blinking portion to 102F.

Remote commander LCD display

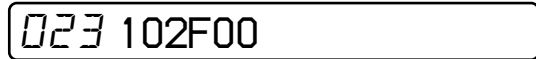

00: Adjusted value

99. Press the **[■]** key.
(00 is blinking)

100. Adjust with the **[VOL+]** key (adjusted value up) or **[VOL-]** key (adjusted value down) so that the adjusted value becomes E5.

Remote commander LCD display

023 102FE5

E5: Adjusted value

101. Press the **[0]** key.
(102F is blinking)
102. Press the **[VOL+]** key three times to change the blinking portion to 1032.

Remote commander LCD display

023 103200

00: Adjusted value

103. Press the **[0]** key.
(00 is blinking)
104. Adjust with the **[VOL+]** key (adjusted value up) or **[VOL-]** key (adjusted value down) so that the adjusted value becomes 90.

Remote commander LCD display

023 103290

90: Adjusted value

105. Press the **[0]** key.
(1032 is blinking)
106. Press the **[VOL+]** key once to change the blinking portion to 1033.

Remote commander LCD display

023 103300

00: Adjusted value

107. Press the **[0]** key.
(00 is blinking)
108. Adjust with the **[VOL+]** key (adjusted value up) or **[VOL-]** key (adjusted value down) so that the adjusted value becomes E5.

Remote commander LCD display

023 1033E5

E5: Adjusted value

109. Press the **[0]** key.
(1033 is blinking)
110. Press the **[VOL+]** key once to change the blinking portion to 1034.

Remote commander LCD display

023 103400

00: Adjusted value

111. Press the **[0]** key.
(00 is blinking)
112. Adjust with the **[VOL+]** key (adjusted value up) or **[VOL-]** key (adjusted value down) so that the adjusted value becomes 06.

Remote commander LCD display

023 103406

06: Adjusted value

113. Press the **[0]** key.
(1034 is blinking)

114. Press the **[VOL+]** key twice to change the blinking portion to 1036.

Remote commander LCD display

023 103600

00: Adjusted value

115. Press the **[0]** key.
(00 is blinking)
116. Adjust with the **[VOL+]** key (adjusted value up) or **[VOL-]** key (adjusted value down) so that the adjusted value becomes 10.

Remote commander LCD display

023 103610

10: Adjusted value

117. Press the **[0]** key.
(1036 is blinking)
118. Press the **[VOL+]** key once to change the blinking portion to 1037.

Remote commander LCD display

023 103700

00: Adjusted value

119. Press the **[0]** key.
(00 is blinking)
120. Adjust with the **[VOL+]** key (adjusted value up) or **[VOL-]** key (adjusted value down) so that the adjusted value becomes E3.

Remote commander LCD display

023 1037E3

E3: Adjusted value

121. Press the **[0]** key.
(1037 is blinking)
122. Press the **[VOL+]** key once to change the blinking portion to 1038.

Remote commander LCD display

023 103800

00: Adjusted value

123. Press the **[0]** key.
(00 is blinking)
124. Adjust with the **[VOL+]** key (adjusted value up) or **[VOL-]** key (adjusted value down) so that the adjusted value becomes 04.

Remote commander LCD display

023 103804

04: Adjusted value

125. Press the **[0]** key.
(1038 is blinking)
126. Press the **[VOL+]** key once to change the blinking portion to 1039.

Remote commander LCD display

023 103900

00: Adjusted value

127. Press the **[0]** key.
(00 is blinking)

128. Adjust with the **[VOL+]** key (adjusted value up) or **[VOL-]** key (adjusted value down) so that the adjusted value becomes E0.

Remote commander LCD display



E0: Adjusted value

129. Press the **[II]** key.
(1039 is blinking)
130. Press the **[VOL+]** key once to change the blinking portion to 103A.

Remote commander LCD display



00: Adjusted value

131. Press the **[■]** key.
(00 is blinking)
132. Adjust with the **[VOL+]** key (adjusted value up) or **[VOL-]** key (adjusted value down) so that the adjusted value becomes 8E.

Remote commander LCD display



8E: Adjusted value

133. Press the **[II]** key.
(103A is blinking)
134. Press the **[VOL+]** key once to change the blinking portion to 103B.

Remote commander LCD display



00: Adjusted value

135. Press the **[■]** key.
(00 is blinking)
136. Adjust with the **[VOL+]** key (adjusted value up) or **[VOL-]** key (adjusted value down) so that the adjusted value becomes 12.

Remote commander LCD display

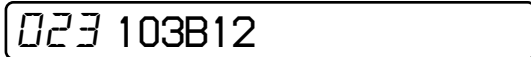

12: Adjusted value

137. Press the **[II]** key.
(103B is blinking)
138. Press the **[VOL+]** key once to change the blinking portion to 103C.

Remote commander LCD display



00: Adjusted value

139. Press the **[■]** key.
(00 is blinking)
140. Adjust with the **[VOL+]** key (adjusted value up) or **[VOL-]** key (adjusted value down) so that the adjusted value becomes 07.

Remote commander LCD display

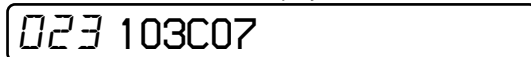

07: Adjusted value

141. Press the **[II]** key.
(103C is blinking)

142. Press the **[VOL+]** key twice to change the blinking portion to 103E.

Remote commander LCD display

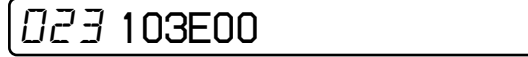

00: Adjusted value

143. Press the **[■]** key.
(00 is blinking)
144. Adjust with the **[VOL+]** key (adjusted value up) or **[VOL-]** key (adjusted value down) so that the adjusted value becomes A0.

Remote commander LCD display



A0: Adjusted value

145. Press the **[II]** key.
(103E is blinking)
146. Press the **[VOL+]** key once to change the blinking portion to 103F.

Remote commander LCD display



00: Adjusted value

147. Press the **[■]** key.
(00 is blinking)
148. Adjust with the **[VOL+]** key (adjusted value up) or **[VOL-]** key (adjusted value down) so that the adjusted value becomes E1.

Remote commander LCD display

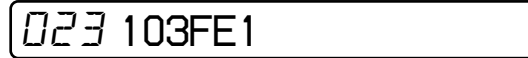

E1: Adjusted value

149. Press the **[II]** key.
(103F is blinking)
150. Press the **[VOL+]** key once to change the blinking portion to 1040.

Remote commander LCD display



00: Adjusted value

151. Press the **[■]** key.
(00 is blinking)
152. Adjust with the **[VOL+]** key (adjusted value up) or **[VOL-]** key (adjusted value down) so that the adjusted value becomes 0E.

Remote commander LCD display



0E: Adjusted value

153. Press the **[II]** key.
(1040 is blinking)
154. Press the **[VOL+]** key once to change the blinking portion to 1041.

Remote commander LCD display



00: Adjusted value

155. Press the **[■]** key.
(00 is blinking)

156. Adjust with the **[VOL+]** key (adjusted value up) or **[VOL-]** key (adjusted value down) so that the adjusted value becomes F0.

Remote commander LCD display

023 1041F0

F0: Adjusted value

157. Press the **[II]** key.
(1041 is blinking)
158. Press the **[VOL+]** key once to change the blinking portion to 1042.

Remote commander LCD display

023 104200

00: Adjusted value

159. Press the **[■]** key.
(00 is blinking)
160. Adjust with the **[VOL+]** key (adjusted value up) or **[VOL-]** key (adjusted value down) so that the adjusted value becomes B0.

Remote commander LCD display

023 1042B0

B0: Adjusted value

161. Press the **[II]** key.
(1042 is blinking)
162. Press the **[VOL+]** key once to change the blinking portion to 1043.

Remote commander LCD display

023 104300

00: Adjusted value

163. Press the **[■]** key.
(00 is blinking)
164. Adjust with the **[VOL+]** key (adjusted value up) or **[VOL-]** key (adjusted value down) so that the adjusted value becomes E1.

Remote commander LCD display

023 1043E1

E1: Adjusted value

165. Press the **[II]** key.
(1043 is blinking)
166. Press the **[VOL+]** key twice to change the blinking portion to 1045.

Remote commander LCD display

023 104500

00: Adjusted value

167. Press the **[■]** key.
(00 is blinking)
168. Adjust with the **[VOL+]** key (adjusted value up) or **[VOL-]** key (adjusted value down) so that the adjusted value becomes B0.

Remote commander LCD display

023 1045B0

B0: Adjusted value

169. Press the **[II]** key.
(1045 is blinking)

170. Press the **[VOL+]** key twice to change the blinking portion to 1047.

Remote commander LCD display

023 104700

00: Adjusted value

171. Press the **[■]** key.
(00 is blinking)
172. Adjust with the **[VOL+]** key (adjusted value up) or **[VOL-]** key (adjusted value down) so that the adjusted value becomes 03.

Remote commander LCD display

023 104703

03: Adjusted value

173. Press the **[II]** key.
(1047 is blinking)
174. Press the **[DISPLAY]** key on the remote commander for several seconds (about 3 seconds) to exit the patch data write mode and display as below.

Remote commander LCD display

023 Patch0A

0A: Adjusted value

175. Press the **[II]** key to write the modified data.
176. The modified data writing is over, if the adjusted value changes to DD.

Remote commander LCD display

023 ***SDD

DD: Adjusted value

177. Turn the power off.

• Modified data writing method (version 2.000)

1. Select the manual mode of the test mode, and set item number 022 (see page 13).

Remote commander LCD display

022 PatC1r CC

2. Press the **[II]** key to initialize the patch data.
(The modified data writing is over, if the adjusted value changes to DD)

Remote commander LCD display

022 ***SDD

DD: Adjusted value

3. Press the **[▶]** key or **[▶▶]** key to set item number 023.

Remote commander LCD display

023 Patch00

00: Adjusted value

4. Press the **[VOL+]** key once to change the adjusted value to 01.
5. Press the **[DISPLAY]** key on the remote commander for several seconds (about 3 seconds) to activate the patch data write mode.

(The following display will appear where 00 is blinking)

Remote commander LCD display

023 102800

00: Adjusted value

6. Adjust with the **[VOL+]** key (adjusted value up) or **[VOL-]** key (adjusted value down) so that the adjusted value becomes B6.

Remote commander LCD display



B6: Adjusted value

7. Press the **[■]** key.
(1028 is blinking)
8. Press the **[VOL+]** key once to change the blinking portion to 1029.

Remote commander LCD display

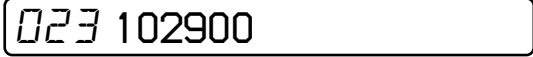

00: Adjusted value

9. Press the **[■]** key.
(00 is blinking)
10. Adjust with the **[VOL+]** key (adjusted value up) or **[VOL-]** key (adjusted value down) so that the adjusted value becomes 95.

Remote commander LCD display



95: Adjusted value

11. Press the **[■]** key.
(1029 is blinking)
12. Press the **[VOL+]** key once to change the blinking portion to 102A.

Remote commander LCD display



00: Adjusted value

13. Press the **[■]** key.
(00 is blinking)
14. Adjust with the **[VOL+]** key (adjusted value up) or **[VOL-]** key (adjusted value down) so that the adjusted value becomes 02.

Remote commander LCD display

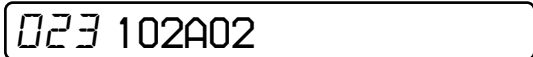

02: Adjusted value

15. Press the **[■]** key.
(102A is blinking)
16. Press the **[VOL+]** key twice to change the blinking portion to 102C.

Remote commander LCD display



00: Adjusted value

17. Press the **[■]** key.
(00 is blinking)
18. Adjust with the **[VOL+]** key (adjusted value up) or **[VOL-]** key (adjusted value down) so that the adjusted value becomes 02.

Remote commander LCD display



02: Adjusted value

19. Press the **[■]** key.
(102C is blinking)

20. Press the **[VOL+]** key once to change the blinking portion to 102D.

Remote commander LCD display



00: Adjusted value

21. Press the **[■]** key.
(00 is blinking)
22. Adjust with the **[VOL+]** key (adjusted value up) or **[VOL-]** key (adjusted value down) so that the adjusted value becomes D0.

Remote commander LCD display



00: Adjusted value

23. Press the **[■]** key.
(102D is blinking)
24. Press the **[VOL+]** key twice to change the blinking portion to 102F.

Remote commander LCD display



00: Adjusted value

25. Press the **[■]** key.
(00 is blinking)
26. Adjust with the **[VOL+]** key (adjusted value up) or **[VOL-]** key (adjusted value down) so that the adjusted value becomes DF.

Remote commander LCD display



DF: Adjusted value

27. Press the **[■]** key.
(102F is blinking)
28. Press the **[VOL+]** key to change the blinking portion to 1048, and press the **[DISPLAY]** key on the remote commander for several seconds (about 3 seconds) to exit the patch data write mode and display as below.

Remote commander LCD display



01: Adjusted value

29. Press the **[VOL+]** key to display as below.

Remote commander LCD display



09: Adjusted value

30. Press the **[DISPLAY]** key on the remote commander for several seconds (about 3 seconds) to activate the patch data write mode.
(The following display will appear where 00 is blinking)

Remote commander LCD display

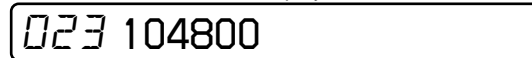

00: Adjusted value

31. Adjust with the **[VOL+]** key (adjusted value up) or **[VOL-]** key (adjusted value down) so that the adjusted value becomes 10.

Remote commander LCD display

023 104810

10: Adjusted value

32. Press the **[II]** key.
(1048 is blinking)
33. Press the **[VOL+]** key twice to change the blinking portion to 104A.

Remote commander LCD display

023 104A00

00: Adjusted value

34. Press the **[■]** key.
(00 is blinking)
35. Adjust with the **[VOL+]** key (adjusted value up) or **[VOL-]** key (adjusted value down) so that the adjusted value becomes 9F.

Remote commander LCD display

023 104A9F

9F: Adjusted value

36. Press the **[II]** key.
(104A is blinking)
37. Press the **[VOL+]** key once to change the blinking portion to 104B.

Remote commander LCD display

023 104B00

00: Adjusted value

38. Press the **[■]** key.
(00 is blinking)
39. Adjust with the **[VOL+]** key (adjusted value up) or **[VOL-]** key (adjusted value down) so that the adjusted value becomes E5.

Remote commander LCD display

023 104BE5

E5: Adjusted value

40. Press the **[II]** key.
(104B is blinking)
41. Press the **[VOL+]** key three times to change the blinking portion to 104E.

Remote commander LCD display

023 104E00

00: Adjusted value

42. Press the **[■]** key.
(00 is blinking)
43. Adjust with the **[VOL+]** key (adjusted value up) or **[VOL-]** key (adjusted value down) so that the adjusted value becomes 90.

Remote commander LCD display

023 104E90

90: Adjusted value

44. Press the **[II]** key.
(104E is blinking)

45. Press the **[VOL+]** key once to change the blinking portion to 104F.

Remote commander LCD display

023 104F00

00: Adjusted value

46. Press the **[■]** key.
(00 is blinking)
47. Adjust with the **[VOL+]** key (adjusted value up) or **[VOL-]** key (adjusted value down) so that the adjusted value becomes E5.

Remote commander LCD display

023 104FE5

E5: Adjusted value

48. Press the **[II]** key.
(104F is blinking)
49. Press the **[VOL+]** key once to change the blinking portion to 1050.

Remote commander LCD display

023 105000

00: Adjusted value

50. Press the **[■]** key.
(00 is blinking)
51. Adjust with the **[VOL+]** key (adjusted value up) or **[VOL-]** key (adjusted value down) so that the adjusted value becomes 06.

Remote commander LCD display

023 105006

06: Adjusted value

52. Press the **[II]** key.
(1050 is blinking)
53. Press the **[VOL+]** key twice to change the blinking portion to 1052.

Remote commander LCD display

023 105200

00: Adjusted value

54. Press the **[■]** key.
(00 is blinking)
55. Adjust with the **[VOL+]** key (adjusted value up) or **[VOL-]** key (adjusted value down) so that the adjusted value becomes 10.

Remote commander LCD display

023 105210

10: Adjusted value

56. Press the **[II]** key.
(1052 is blinking)
57. Press the **[VOL+]** key once to change the blinking portion to 1053.

Remote commander LCD display

023 105300

00: Adjusted value

58. Press the **[■]** key.
(00 is blinking)

59. Adjust with the **[VOL+]** key (adjusted value up) or **[VOL-]** key (adjusted value down) so that the adjusted value becomes E3.

Remote commander LCD display

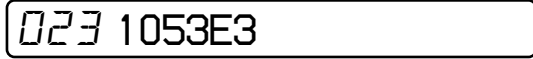

E3: Adjusted value

60. Press the **[■]** key.
(1053 is blinking)
61. Press the **[VOL+]** key once to change the blinking portion to 1054.

Remote commander LCD display

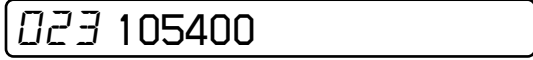

00: Adjusted value

62. Press the **[■]** key.
(00 is blinking)
63. Adjust with the **[VOL+]** key (adjusted value up) or **[VOL-]** key (adjusted value down) so that the adjusted value becomes 04.

Remote commander LCD display

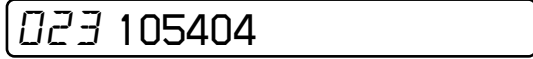

04: Adjusted value

64. Press the **[■]** key.
(1054 is blinking)
65. Press the **[VOL+]** key once to change the blinking portion to 1055.

Remote commander LCD display

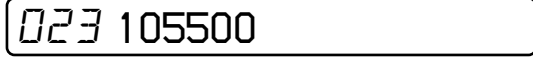

00: Adjusted value

66. Press the **[■]** key.
(00 is blinking)
67. Adjust with the **[VOL+]** key (adjusted value up) or **[VOL-]** key (adjusted value down) so that the adjusted value becomes E0.

Remote commander LCD display

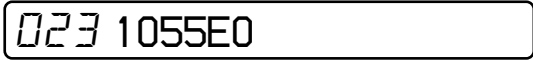

E0: Adjusted value

68. Press the **[■]** key.
(1055 is blinking)
69. Press the **[VOL+]** key once to change the blinking portion to 1056.

Remote commander LCD display

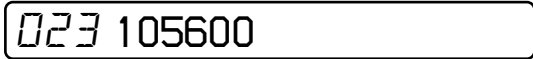

00: Adjusted value

70. Press the **[■]** key.
(00 is blinking)
71. Adjust with the **[VOL+]** key (adjusted value up) or **[VOL-]** key (adjusted value down) so that the adjusted value becomes 8E.

Remote commander LCD display

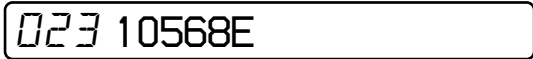

8E: Adjusted value

72. Press the **[■]** key.
(1056 is blinking)

73. Press the **[VOL+]** key once to change the blinking portion to 1057.

Remote commander LCD display

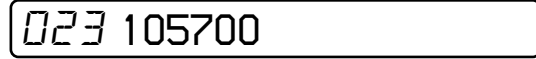

00: Adjusted value

74. Press the **[■]** key.
(00 is blinking)
75. Adjust with the **[VOL+]** key (adjusted value up) or **[VOL-]** key (adjusted value down) so that the adjusted value becomes 12.

Remote commander LCD display

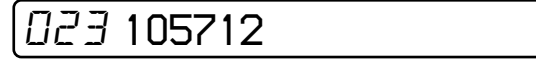

12: Adjusted value

76. Press the **[■]** key.
(1057 is blinking)
77. Press the **[VOL+]** key once to change the blinking portion to 1058.

Remote commander LCD display

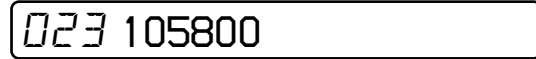

00: Adjusted value

78. Press the **[■]** key.
(00 is blinking)
79. Adjust with the **[VOL+]** key (adjusted value up) or **[VOL-]** key (adjusted value down) so that the adjusted value becomes 07.

Remote commander LCD display

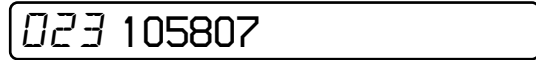

07: Adjusted value

80. Press the **[■]** key.
(1058 is blinking)
81. Press the **[VOL+]** key twice to change the blinking portion to 105A.

Remote commander LCD display

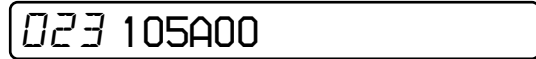

00: Adjusted value

82. Press the **[■]** key.
(00 is blinking)
83. Adjust with the **[VOL+]** key (adjusted value up) or **[VOL-]** key (adjusted value down) so that the adjusted value becomes A0.

Remote commander LCD display



A0: Adjusted value

84. Press the **[■]** key.
(105A is blinking)
85. Press the **[VOL+]** key once to change the blinking portion to 105B.

Remote commander LCD display

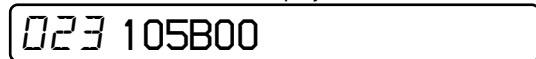

00: Adjusted value

86. Press the **[■]** key.
(00 is blinking)

87. Adjust with the **[VOL+]** key (adjusted value up) or **[VOL-]** key (adjusted value down) so that the adjusted value becomes E1.

Remote commander LCD display

023 105BE1

E1: Adjusted value

88. Press the **[II]** key.
(105B is blinking)
89. Press the **[VOL+]** key once to change the blinking portion to 105C.

Remote commander LCD display

023 105C00

00: Adjusted value

90. Press the **[■]** key.
(00 is blinking)
91. Adjust with the **[VOL+]** key (adjusted value up) or **[VOL-]** key (adjusted value down) so that the adjusted value becomes 0E.

Remote commander LCD display

023 105C0E

0E: Adjusted value

92. Press the **[II]** key.
(105C is blinking)
93. Press the **[VOL+]** key once to change the blinking portion to 105D.

Remote commander LCD display

023 105D00

00: Adjusted value

94. Press the **[■]** key.
(00 is blinking)
95. Adjust with the **[VOL+]** key (adjusted value up) or **[VOL-]** key (adjusted value down) so that the adjusted value becomes F0.

Remote commander LCD display

023 105DF0

F0: Adjusted value

96. Press the **[II]** key.
(105D is blinking)
97. Press the **[VOL+]** key once to change the blinking portion to 105E.

Remote commander LCD display

023 105E00

00: Adjusted value

98. Press the **[■]** key.
(00 is blinking)
99. Adjust with the **[VOL+]** key (adjusted value up) or **[VOL-]** key (adjusted value down) so that the adjusted value becomes B0.

Remote commander LCD display

023 105EB0

B0: Adjusted value

100. Press the **[II]** key.
(105E is blinking)

101. Press the **[VOL+]** key once to change the blinking portion to 105F.

Remote commander LCD display

023 105F00

00: Adjusted value

102. Press the **[■]** key.
(00 is blinking)
103. Adjust with the **[VOL+]** key (adjusted value up) or **[VOL-]** key (adjusted value down) so that the adjusted value becomes E1.

Remote commander LCD display

023 105FE1

E1: Adjusted value

104. Press the **[II]** key.
(105F is blinking)
105. Press the **[VOL+]** key twice to change the blinking portion to 1061.

Remote commander LCD display

023 106100

00: Adjusted value

106. Press the **[■]** key.
(00 is blinking)
107. Adjust with the **[VOL+]** key (adjusted value up) or **[VOL-]** key (adjusted value down) so that the adjusted value becomes B0.

Remote commander LCD display

023 1061B0

B0: Adjusted value

108. Press the **[II]** key.
(1061 is blinking)
109. Press the **[VOL+]** key twice to change the blinking portion to 1063.

Remote commander LCD display

023 106300

00: Adjusted value

110. Press the **[■]** key.
(00 is blinking)
111. Adjust with the **[VOL+]** key (adjusted value up) or **[VOL-]** key (adjusted value down) so that the adjusted value becomes 03.

Remote commander LCD display

023 106303

03: Adjusted value

112. Press the **[II]** key.
(1063 is blinking)
113. Press the **[DISPLAY]** key on the remote commander for several seconds (about 3 seconds) to exit the patch data write mode and display as below.

Remote commander LCD display

023 Patch 09

09: Adjusted value

114. Press the **[II]** key to write the modified data.

115. The modified data writing is over, if the adjusted value changes to DD.

Remote commander LCD display

023 ***SDD

DD: Adjusted value

116. Turn the power off.

SECTION 6
DIAGRAMS

6-1. BLOCK DIAGRAM – SERVO Section –

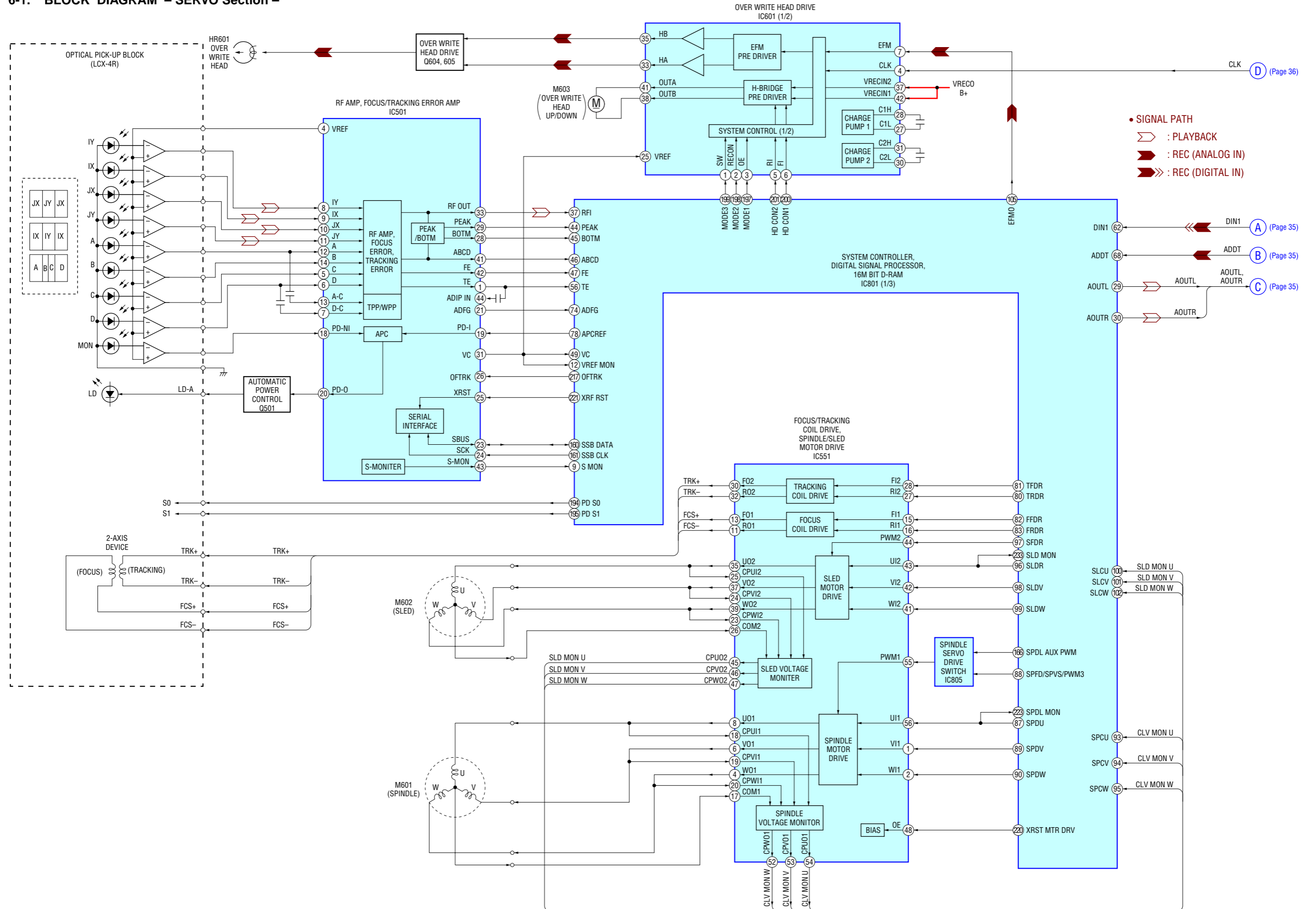

6-2. BLOCK DIAGRAM – AUDIO Section –

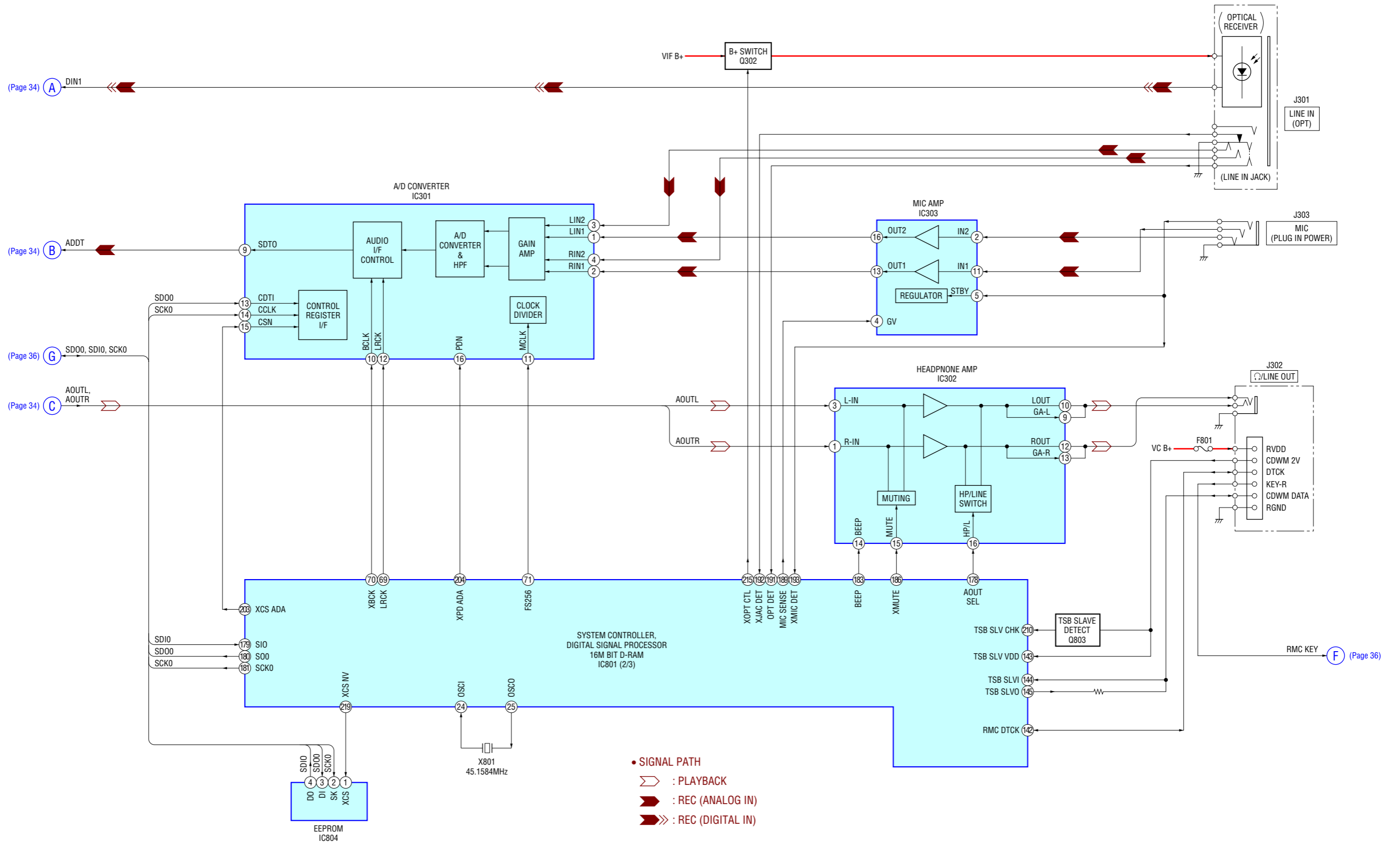

6-3. BLOCK DIAGRAM – KEY CONTROL/DISPLAY/POWER SUPPLY Section –

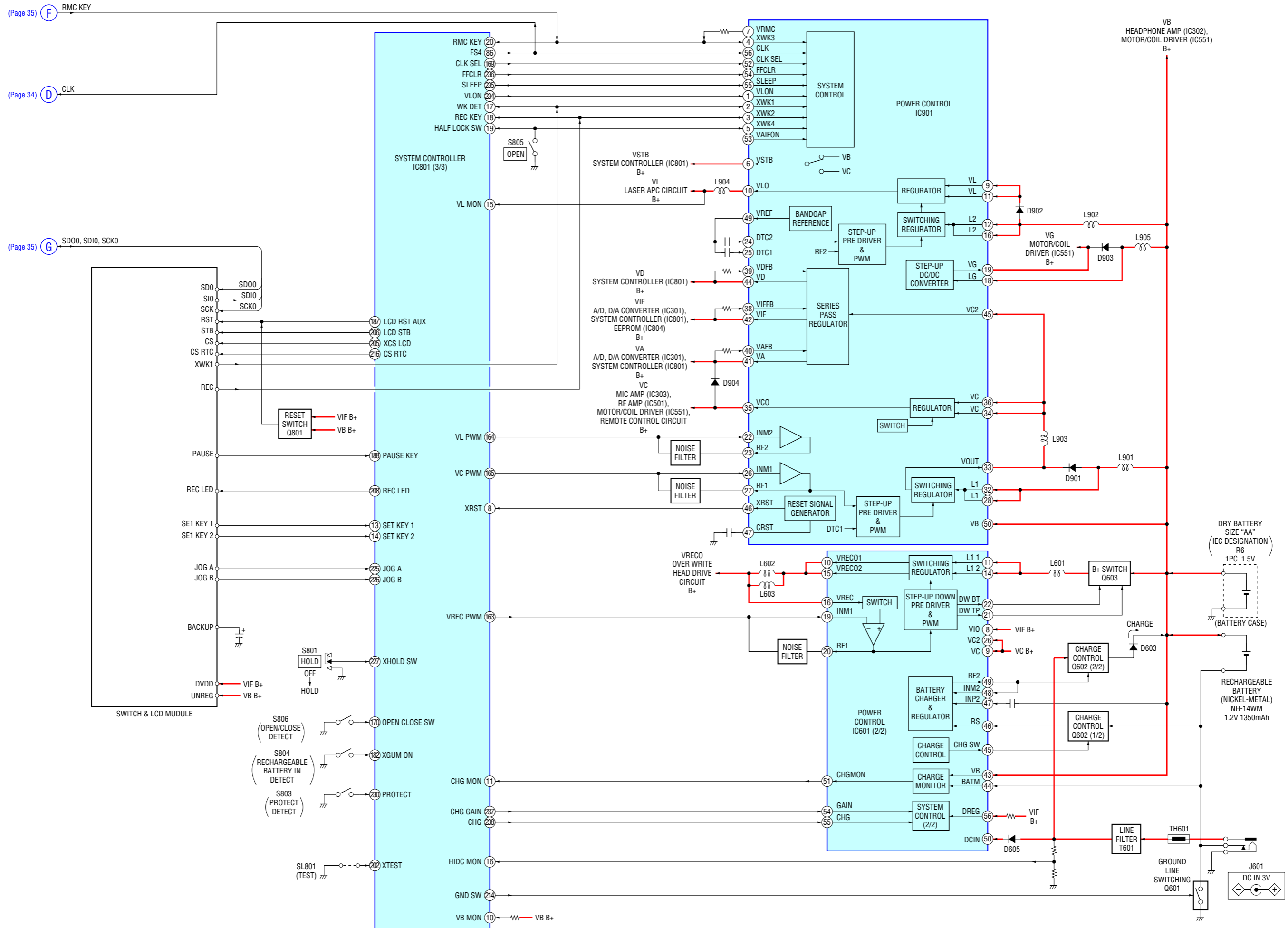

6-4. NOTE FOR PRINTED WIRING BOARDS AND SCHEMATIC DIAGRAMS

Note on Printed Wiring Board:

- : parts extracted from the component side.
- : parts extracted from the conductor side.
- : Pattern from the side which enables seeing. (The other layers' patterns are not indicated.)

Caution:
 Pattern face side: Parts on the pattern face side seen from (Conductor Side) the pattern face are indicated.
 Parts face side: Parts on the parts face side seen from (Component Side) the parts face are indicated.

- MAIN board is four-layer printed board. However, the patterns of layers 2 and 3 have not been included in this diagrams.

* Replacement of IC801 used in this set requires a special tool.

Lead Layouts

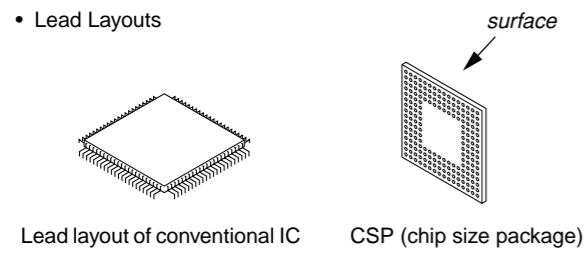

Note on Schematic Diagram:

- All capacitors are in μF unless otherwise noted. pF: $\mu\mu\text{F}$ 50 WV or less are not indicated except for electrolytics and tantalums.
- All resistors are in Ω and $1/4\text{W}$ or less unless otherwise specified.
- % : indicates tolerance.
- : panel designation.

Note: The components identified by mark \triangle or dotted line with mark \triangle are critical for safety. Replace only with part number specified.

- : B+ Line.
- Total current is measured with MD installed.
- Power voltage is dc 3 V and fed with regulated dc power supply from external power voltage jack.
- Voltages and waveforms are dc with respect to ground in playback mode.
- no mark : PLAYBACK
- () : REC
- * : Impossible to measure
- Voltages are taken with a VOM (Input impedance 10 M Ω). Voltage variations may be noted due to normal production tolerances.
- Waveforms are taken with a oscilloscope. Voltage variations may be noted due to normal production tolerances.
- Circled numbers refer to waveforms.
- Signal path.
- ⊞ : PLAYBACK
- : REC (ANALOG IN)
- : REC (DIGITAL IN)

* Replacement of IC801 used in this set requires a special tool.

- The voltage and waveform of CSP (chip size package) cannot be measured, because its lead layout is different form that of conventional IC.

Waveforms

① IC601 ⊕ (CLK) (PLAYBACK mode)
 500 mV/DIV, 2 μs /DIV

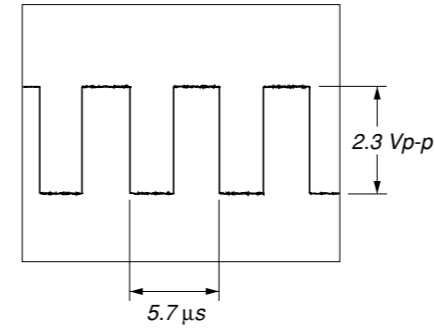

② IC901 ⊕ (CLK) (PLAYBACK mode)
 500 mV/DIV, 2 μs /DIV

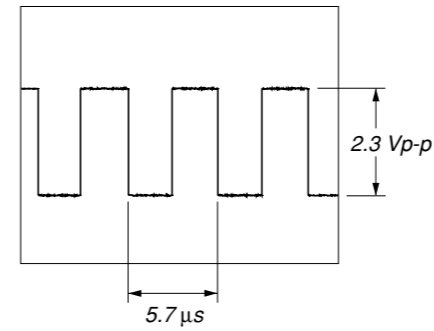

6-5. PRINTED WIRING BOARD – MAIN board (Component Side) –  :Uses unleaded solder.

• Semiconductor Location

Ref. No.	Location
D603	F-8
IC805	E-6
Q602	G-9

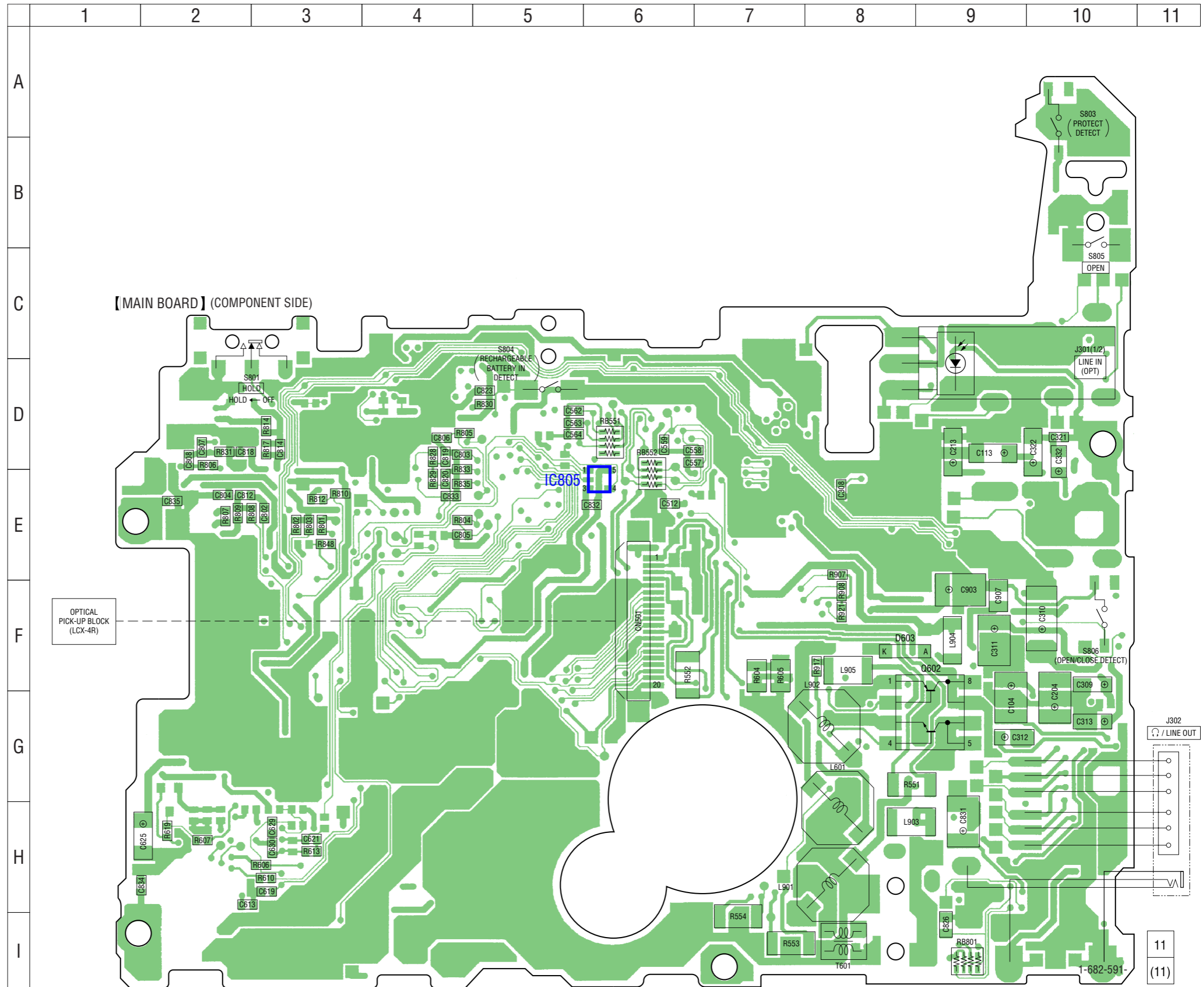

6-6. PRINTED WIRING BOARD – MAIN board (Conductor Side) –  :Uses unleaded solder.

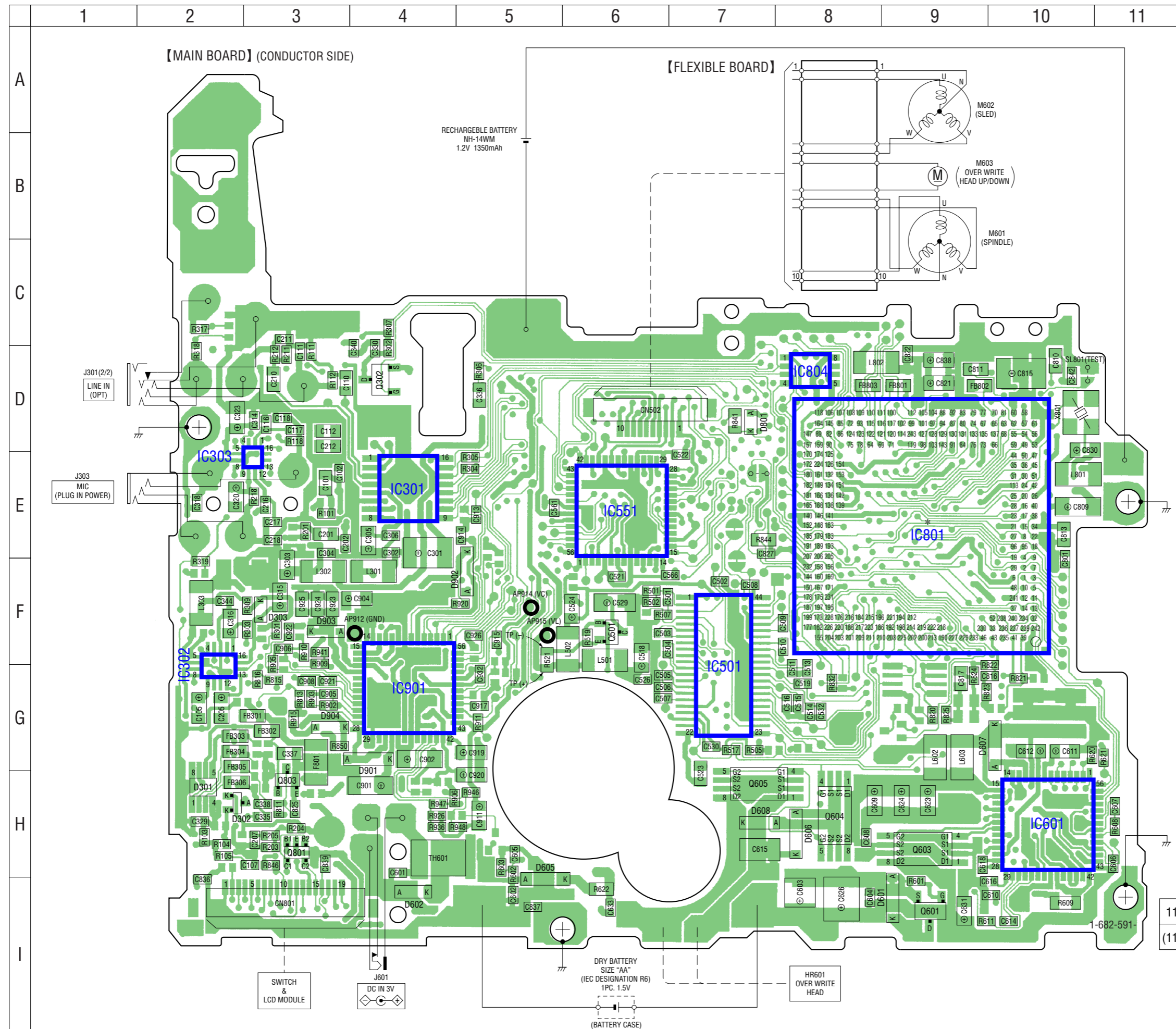

• Semiconductor Location

Ref. No.	Location
D301	H-2
D302	H-2
D303	F-3
D601	I-9
D602	I-4
D605	I-5
D606	H-8
D607	G-10
D608	H-7
D801	D-7
D901	G-4
D902	F-5
D903	F-3
D904	G-3
IC301	E-4
IC302	G-2
IC303	E-3
IC501	G-7
IC551	E-6
IC601	H-10
IC801	E-9
IC804	D-8
IC901	G-4
Q302	D-4
Q501	F-6
Q601	I-9
Q603	H-9
Q604	H-8
Q605	H-7
Q801	H-3
Q803	H-3

6-7. SCHEMATIC DIAGRAM – MAIN Board (1/4) – • See page 37 for Waveform. • See page 44 for IC Block Diagrams.

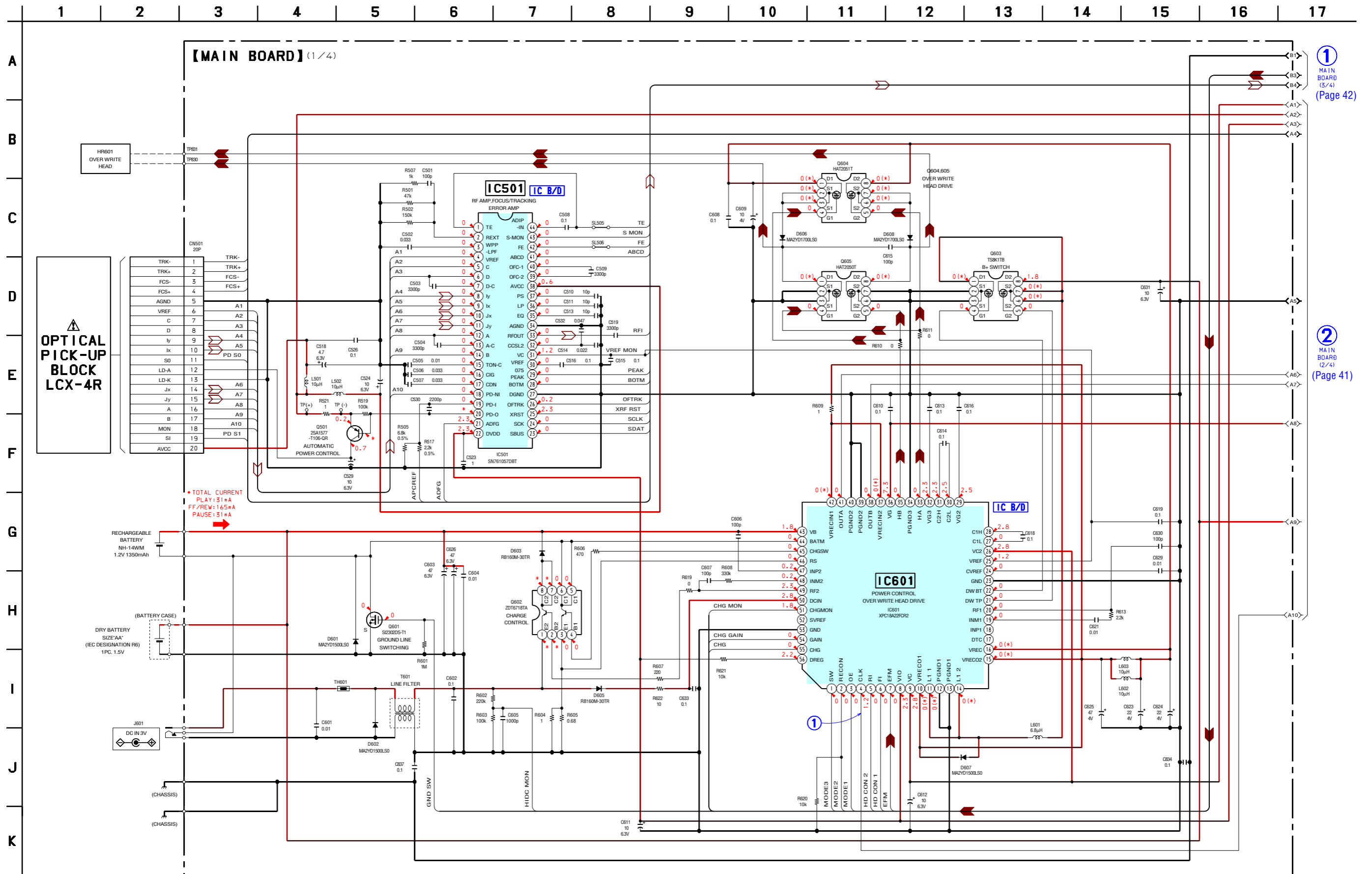

1 MAIN BOARD (3/4) (Page 42)

2 MAIN BOARD (2/4) (Page 41)

6-8. SCHEMATIC DIAGRAM – MAIN Board (2/4) – • See page 37 for Waveform. • See page 44 for IC Block Diagrams.

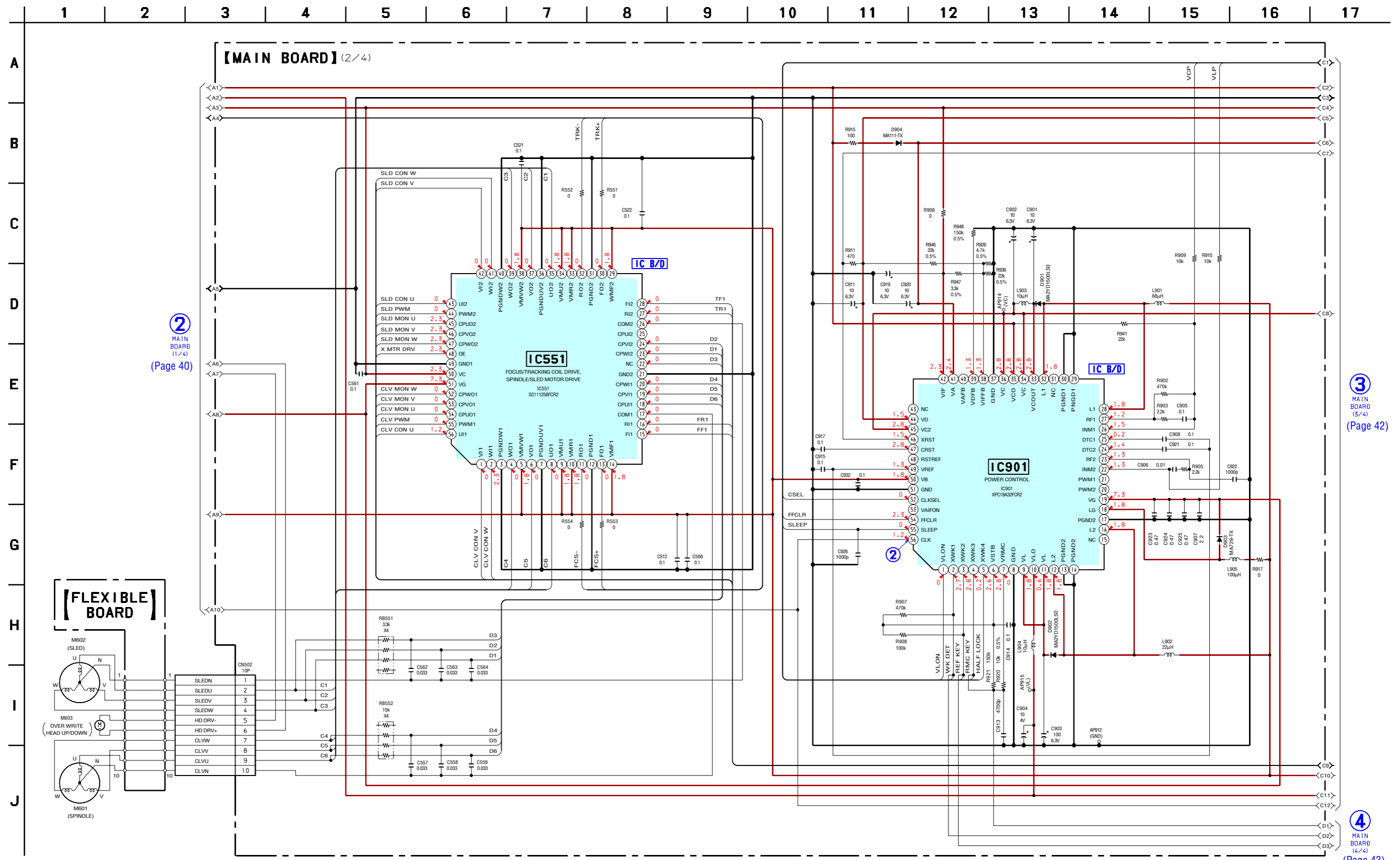

6-9. SCHEMATIC DIAGRAM – MAIN Board (3/4) –

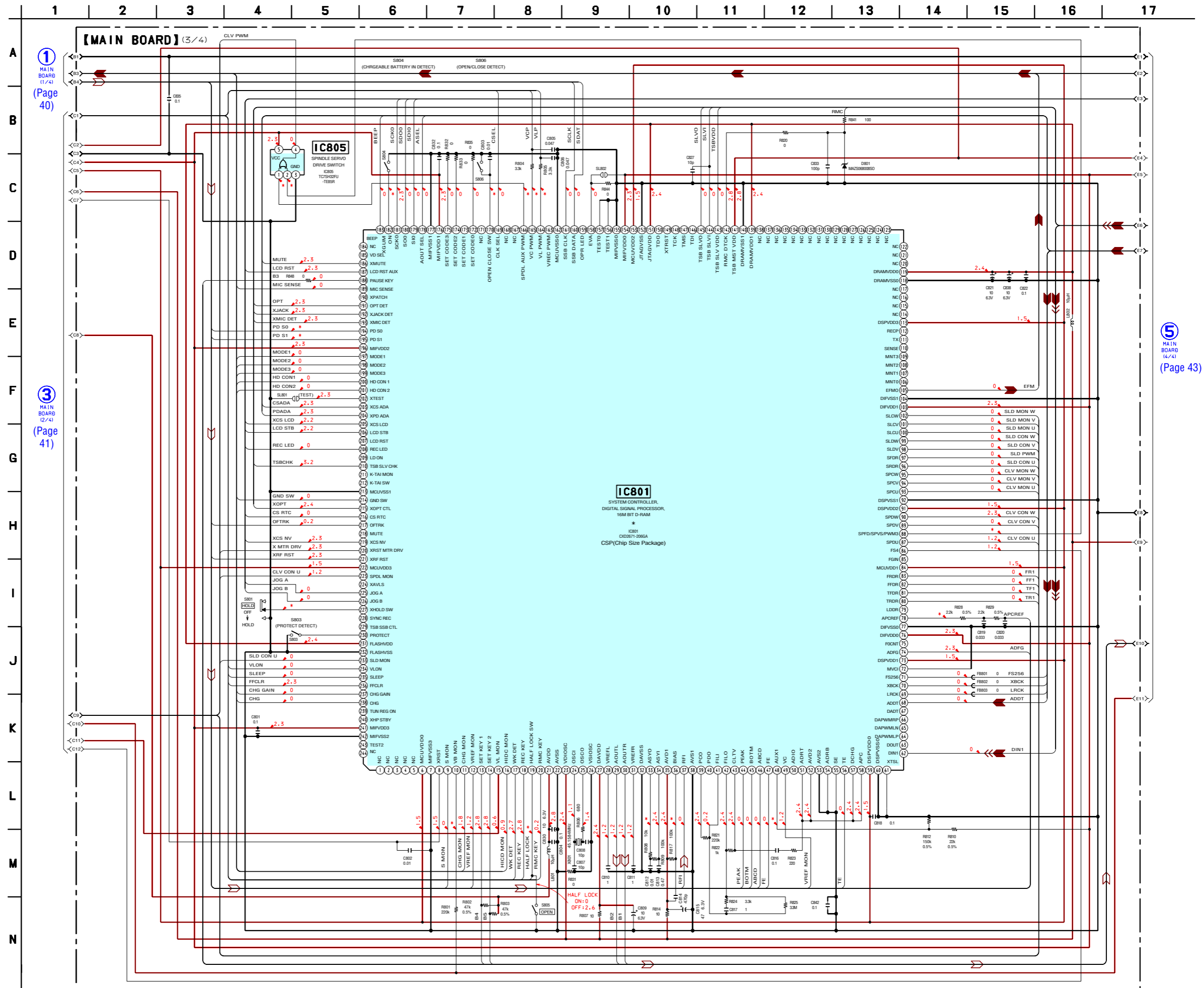

6-10. SCHEMATIC DIAGRAM – MAIN Board (4/4) – • See page 44 for IC Block Diagrams.

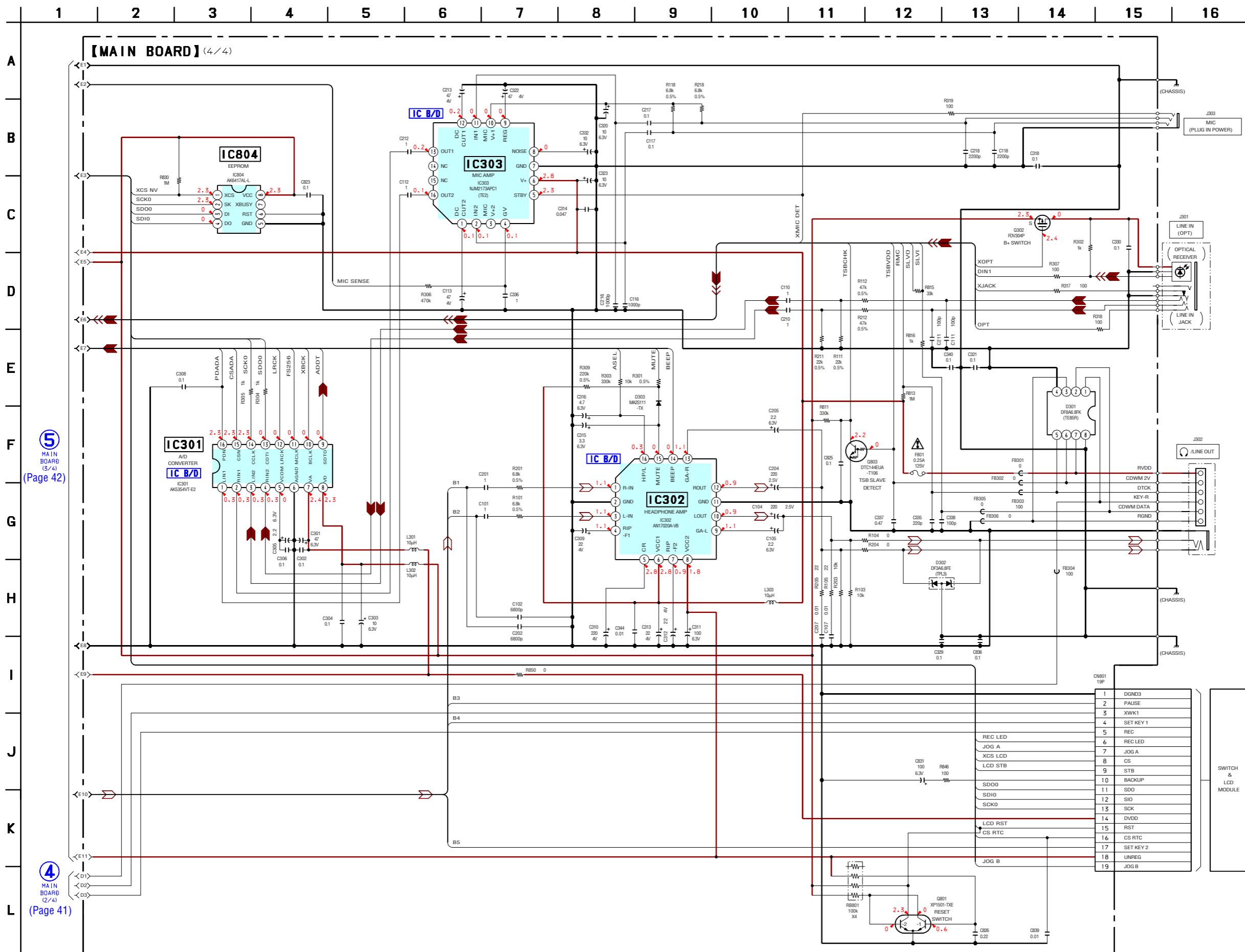

MZ-R909

• IC Block Diagrams

IC301 AK5354VT-E2

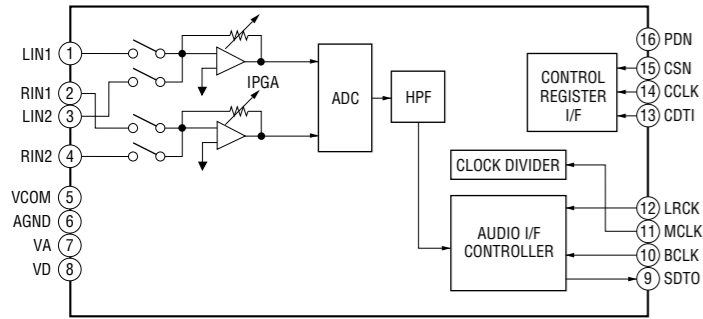

IC303 NJM2173APC1 (TE2)

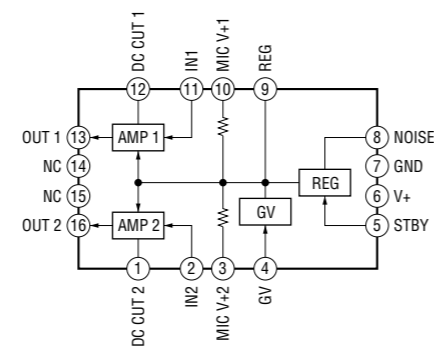

IC501 SN761057DBT

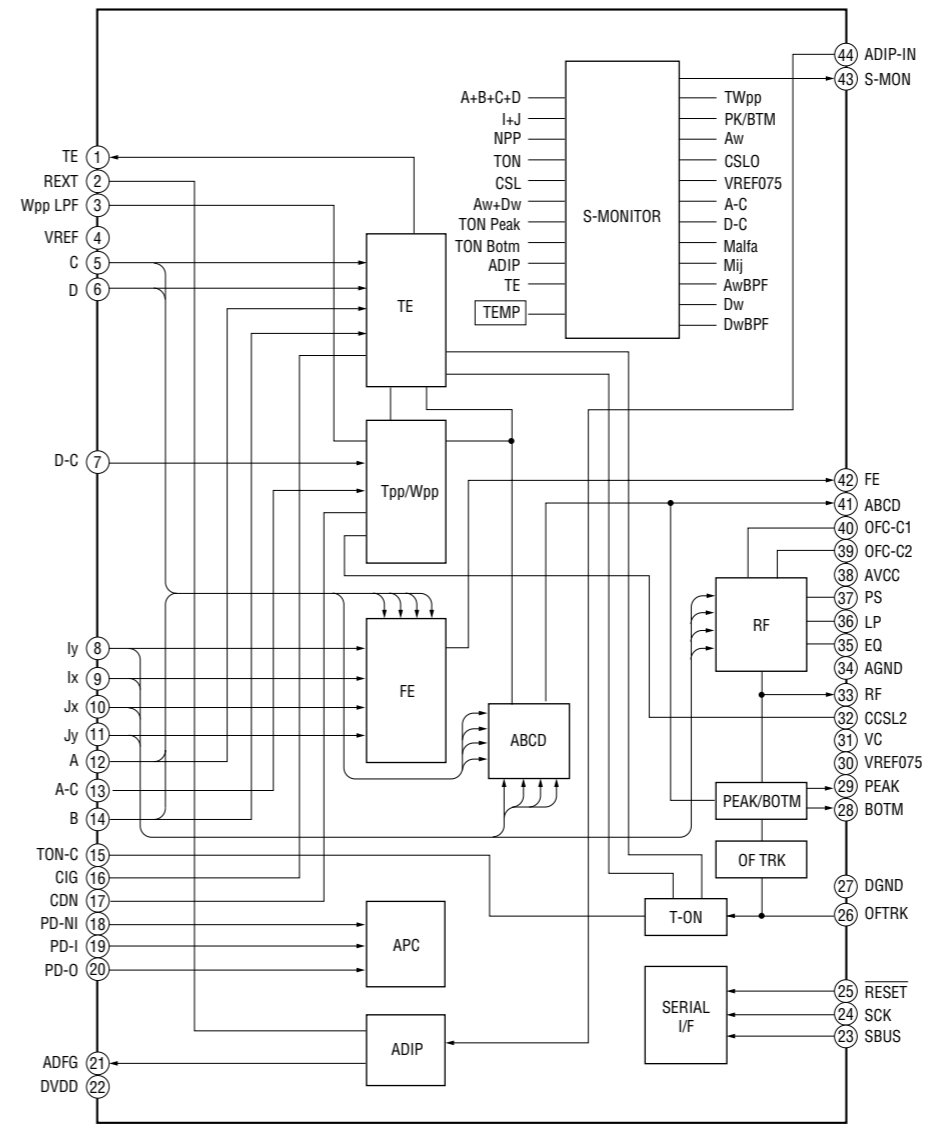

IC302 AN17020A-VB

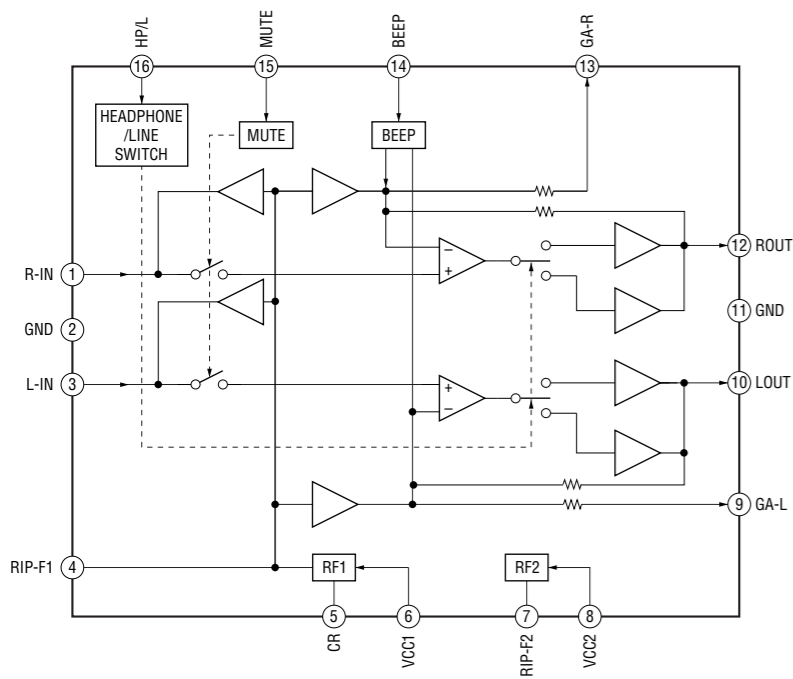

IC551 SC111258FCR2

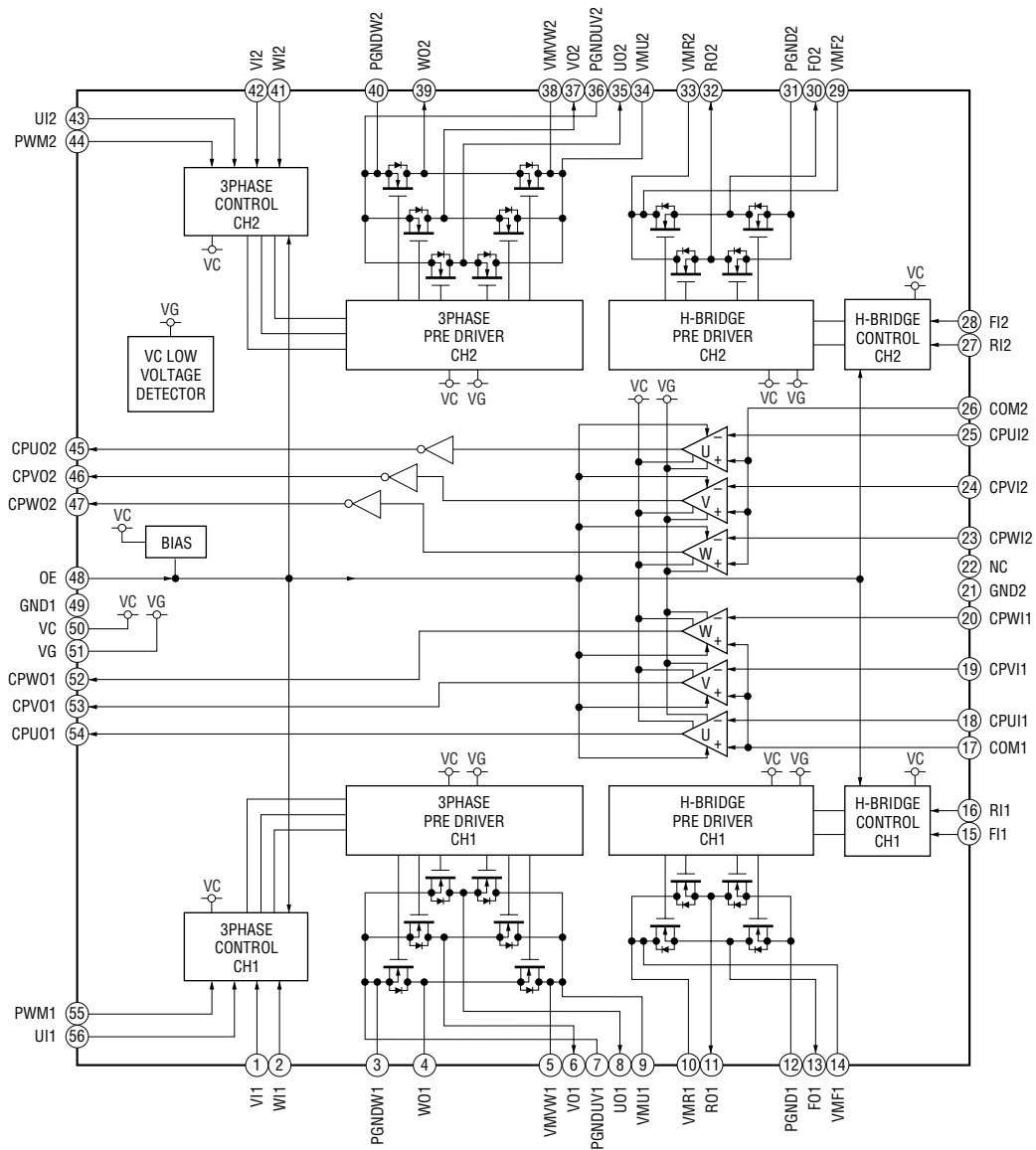

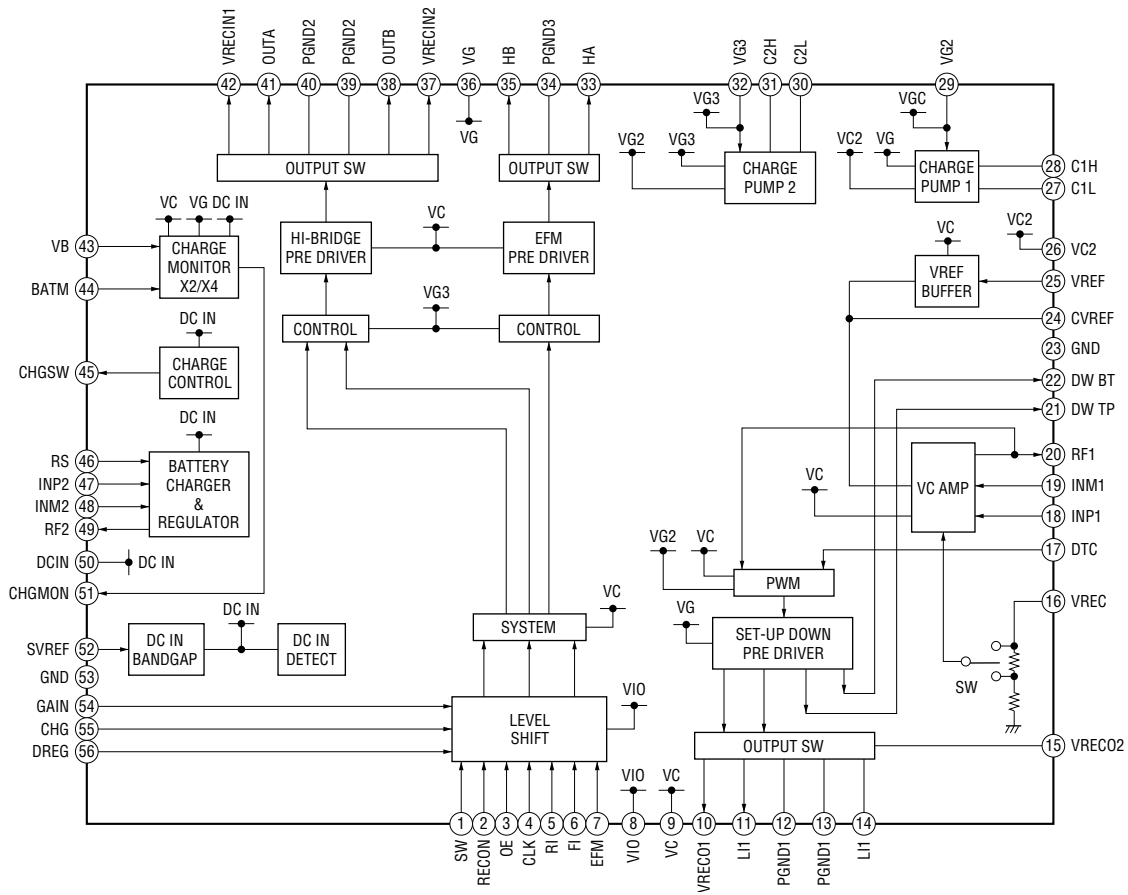

IC901 XPC18A32FCR2

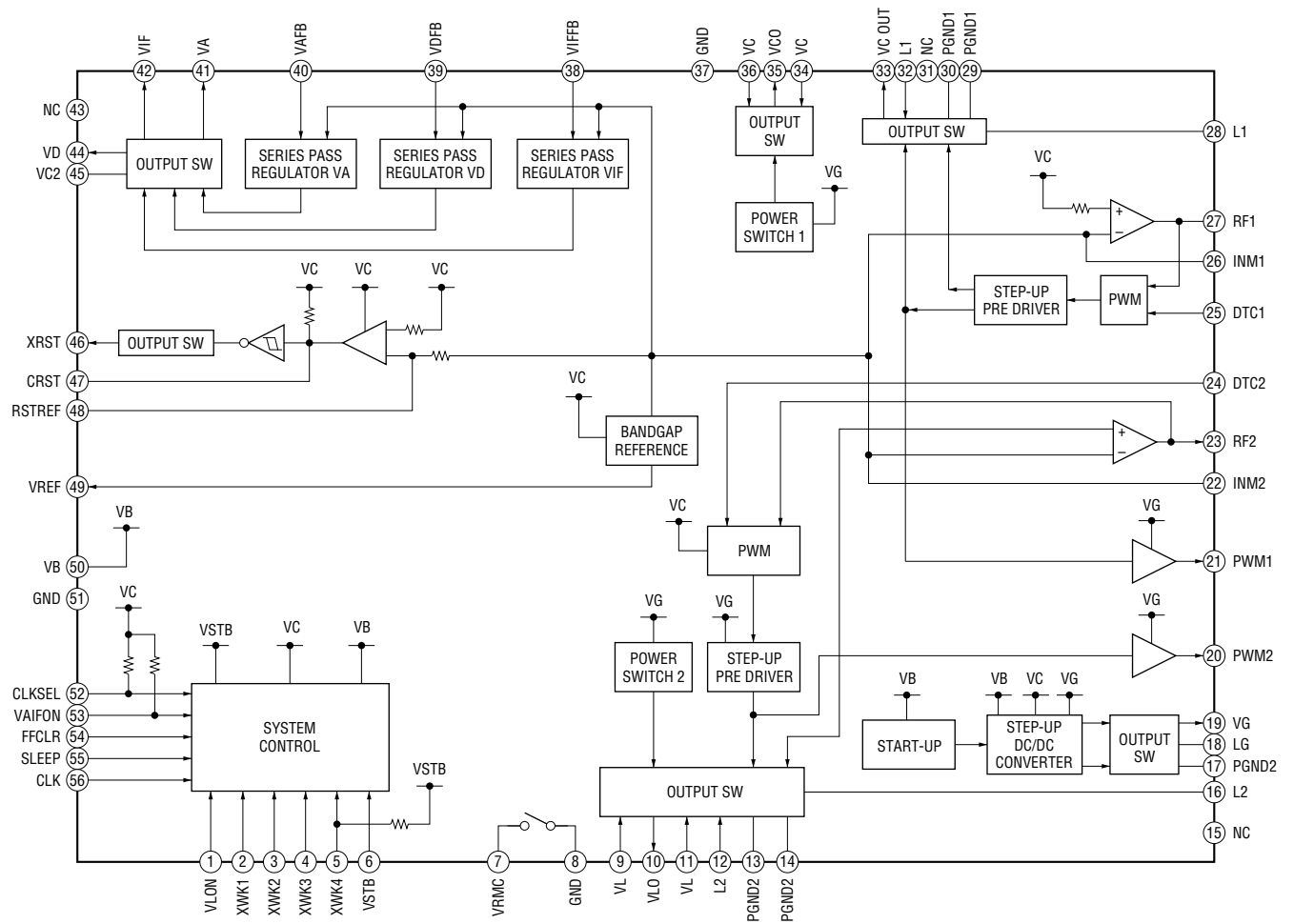

6-11. IC PIN FUNCTION DESCRIPTION

• IC501 SN761057DBT (RF AMP, FOCUS/TRACKING ERROR AMP)

Pin No.	Pin Name	I/O	Description
1	TE	O	Tracking error signal output to the system controller (IC801)
2	REXT	—	Connect terminal to the external resistor for ADIP amp control
3	WPPLPF	—	Connect terminal to the external capacitor for TPP/WPP low-pass filter
4	VREF	O	Reference voltage output terminal
5	C	I	Signal (C) input from the optical pickup detector
6	D	I	Signal (D) input from the optical pickup detector
7	D-C	I	Signal (D) input from the optical pickup detector (AC input)
8	IY	I	I-V converted RF signal (IY) input from the optical pickup detector
9	IX	I	I-V converted RF signal (IX) input from the optical pickup detector
10	JX	I	I-V converted RF signal (JX) input from the optical pickup detector
11	JY	I	I-V converted RF signal (JY) input from the optical pickup detector
12	A	I	Signal (A) input from the optical pickup detector
13	A-C	I	Signal (A) input from the optical pickup detector (AC input)
14	B	I	Signal (B) input from the optical pickup detector
15	TON-C	—	Connect terminal to the external capacitor for TON hold
16	CIG	—	Connect terminal to the external capacitor for the low-pass filter of NPP divider denominator
17	CDN	—	Connect terminal to the external capacitor for the low-pass filter of CSL divider denominator
18	PD-NI	I	Light amount monitor input terminal (non-invert input)
19	PD-I	I	Reference PWM signal input for the laser automatic power control from the system controller (IC801)
20	PD-O	O	Light amount monitor output terminal
21	ADFG	O	ADIP duplex FM signal (22.05kHz \pm 1kHz) output to the system controller (IC801)
22	DVDD	—	Power supply terminal (+2.3V) (digital system)
23	SBUS	I/O	SSB serial data input/output with the system controller (IC801)
24	SCK	I	SSB serial clock signal input from the system controller (IC801)
25	XRST	I	Reset signal input from the system controller (IC801) "L": reset
26	OFTRK	I	Off track signal input from the system controller (IC801)
27	DGND	—	Ground terminal (digital system)
28	BOTM	O	Bottom hold signal output of the light amount signal (RF/ABCD) to the system controller (IC 801)
29	PEAK	O	Peak hold signal output of the light amount signal (RF/ABCD) to the system controller (IC 801)
30	VREF075	—	Connect terminal to the external capacitor for the internal reference voltage
31	VC	O	Middle point voltage (+1.2V) generation output terminal
32	CCSL2	—	Connect terminal to the external capacitor for TPP/WPP low-pass filter
33	RF OUT	O	Playback EFM RF signal output to the system controller (IC801)
34	AGND	—	Ground terminal (analog system)
35 to 37	EQ, LP, PS	—	Connect terminal to the external capacitor for the RF equalizer
38	AVCC	—	Power supply terminal (analog system)
39, 40	OFC2, OFC-1	—	Connect terminal to the external capacitor for RF AC coupling
41	ABCD	O	Light amount signal (ABCD) output to the system controller (IC801)
42	FE	O	Focus error signal output to the system controller (IC801)
43	S-MON	O	Servo signal monitor output to the system controller (IC801)
44	ADIP-IN	I	ADIP duplex FM signal (22.05kHz \pm 1kHz) input terminal (not used in this set)

• IC801 CXD2671-206GA (SYSTEM CONTROLLER, DIGITAL SIGNAL PROCESSOR, 16M BIT D-RAM)

Pin No.	Pin Name	I/O	Description
1 to 5	NC	—	Not used (open)
6	MCUVDD0	—	Power supply terminal (for microcomputer block) (+1.5V)
7	MIFVSS3	—	Ground terminal (for microcomputer I/F)
8	XRST	I	System reset signal input terminal from the power control (IC901) "L": reset
9	S MON	I	Servo signal monitor input terminal (A/D input) from RF amp (IC501)
10	VB MON	I	Voltage monitor input terminal of UNREG power supply (A/D input)
11	CHG MON	I	Charge voltage monitor input terminal (A/D input) from XPC18A22FCR2 (IC601)
12	VREF MON	I	Clear reference monitor voltage input terminal (A/D input) from RF amp (IC501)
13, 14	SET KEY 1, SET KEY 2	I	Key input terminal from the switch & LCD module (A/D input)
15	VL MON	I	VL voltage monitor input terminal (A/D input)
16	HIDC MON	I	HIGH DC voltage monitor input terminal (A/D input)
17	WK DET	I	Set key start switching detection signal input terminal (A/D input)
18	REC KEY	I	REC key input terminal (A/D input)
19	HALF LOCK SW	I	Open button detection switch (S805) input terminal (A/D input) Input "L" when the open button is pressed. Input "H" in other cases.
20	RMC KEY	I	Key input terminal (A/D input) from the remote commander attached headphone
21	AVDD	—	Power supply terminal (for the analog circuit block) (+2.8V)
22	AVSS	—	Ground terminal (for the analog circuit block)
23	VDIOSC	—	Power supply terminal (for OSC cell) (+2.4V)
24	OSCI	I	System clock (45.1584MHz) input terminal
25	OSCO	O	System clock (45.1584MHz) output terminal
26	VSIOSC	—	Ground terminal (for OSC cell)
27	DAVDD	—	Power supply terminal (for the built-in D/A converter) (+2.4V)
28	VREFL	I	Reference voltage input terminal (for the internal D/A converter L-CH)
29	AOUTL	O	Built-in D/A converter (L-CH) output terminal
30	AOUTR	O	Built-in D/A converter (R-CH) output terminal
31	VREFR	I	Reference voltage input terminal (for the built-in D/A converter R-CH)
32	DAVSS	—	Ground terminal (for the built-in D/A converter)
33	ASYO	O	Playback EFM duplex signal output terminal
34	ASYI	I	Playback EFM comparison slice level input terminal
35	AVD1	—	Ground terminal (for the analog) (+2.4V)
36	BIAS	I	Bias current input terminal for the playback EFM comparison
37	RFI	I	Playback EFM RF signal input from RF amp (IC501)
38	AVS1	—	Ground terminal (for the analog)
39	PCO	O	Phase comparison output terminal for the playback EFM system master PLL
40	PDO	O	Phase comparison output terminal for the analog PLL Not used (open)
41	FILI	I	Filter input terminal for the playback EFM system master PLL
42	FILO	O	Filter output terminal for the playback EFM system master PLL
43	CLTV	I	Internal VCO control voltage input for the playback EFM system master PLL
44	PEAK	I	Peak hold signal input of the light amount signal (RF/ABCD) from RF amp (IC501)
45	BOTM	I	Bottom hold signal input of the light amount signal (RF/ABCD) from RF amp (IC501)
46	ABCD	I	Light amount signal (ABCD) input from RF amp (IC501)
47	FE	I	Focus error signal input from RF amp (IC501)
48	AUX1	I	Support signal (I3 signal/temperature signal) input terminal (A/D input)

Pin No.	Pin Name	I/O	Description
49	VC	I	Middle point voltage (+1.2V) input terminal
50	ADIO	O	Monitor output terminal of A/D converter input signal Not used (open)
51	ADRT	I	A/D converter the upper limit voltage input terminal (fixed at "H" in this set)
52	AVD2	—	Power supply terminal (for the analog) (+2.4V)
53	AVS2	—	Ground terminal (for the analog)
54	ADRB	I	A/D converter the lower limit voltage input (fixed at "L" in this set)
55	SE	I	Sled error signal input terminal Not used (fixed at "L")
56	TE	I	Tracking error signal input from RF amp (IC501)
57	DCHG	—	Connecting analog power supply of the low impedance (fixed at "H" in this set)
58	APC	I	Error signal input for the laser automatic power control Not used (fixed at "H")
59	DSPVDD0	—	Power supply terminal (for DSP block) (+1.5V)
60	DSPVSS0	—	Ground terminal (for DSP block)
61	XTSL	I	Input terminal for the frequency set up of the system clock "L": 45.1584MHz, "H": 22.5792MHz (fixed at "L" in this set)
62	DIN1	I	Input terminal of the record system digital audio signal
63	DOUT	O	Output terminal of the playback system digital audio signal Not used (open)
64	DAPWMLP	O	D/A converter PWM output terminal (L-CH right phase) Not used (open)
65	DAPWMLN	O	D/A converter PWM output terminal (L-CH reverse phase) Not used (open)
66	DAPWMRP	O	D/A converter PWM output terminal (R-CH right phase) Not used (open)
67	DADT	O	Audio data output to the external A/D converter Not used (open)
68	ADDT	I	Data input from the external A/D converter (IC301)
69	LRCK	O	L/R sampling block signal (44.1KHz) output to the external A/D converter (IC301)
70	XBCK	O	Bit clock signal (2.8224MHz) output to the external A/D converter (IC301)
71	FS256	O	11.2896MHz clock signal output to the external A/D converter (IC301)
72	MVCI	I	Clock signal input from the external VCO Not used (fixed at "L")
73	DSPVDD1	—	Power supply terminal (for DSP block) (+1.5V)
74	ADFG	I	ADIP duplex FM signal (20.05±1kHz) input from RF amp (IC501)
75	F0CNT	O	Filter cut off control signal output terminal Not used (open)
76	DIFVDD0	—	Power supply terminal (for DSP I/F) (+2.3V)
77	DIFVSS0	—	Ground terminal (for DSP I/F)
78	APCREF	O	Reference PWM signal output for the laser automatic power control to RF amp (IC501)
79	LDDR	O	PWM signal output for the laser automatic power control Not used (open)
80	TRDR	O	Tracking servo drive PWM signal output (-) to the motor driver (IC551)
81	TFDR	O	Tracking servo drive PWM signal output (+) to the motor driver (IC551)
82	FFDR	O	Focus servo drive PWM signal output (+) to the motor driver (IC551)
83	FRDR	O	Focus servo drive PWM signal output (-) to the motor driver (IC551)
84	MCUVDD1	—	Power supply terminal (for the microcomputer block) (+1.5V)
85	FGIN	I	FG signal input terminal for the spindle CAV servo Not used (open)
86	FS4	O	176.4kHz clock signal output to the power control (IC601, IC901)
87	SPDU	O	Spindle motor drive control signal output (U) to the motor driver (IC551)
88	SPFD/SPVS/ PWM3	O	Spindle servo drive PWM signal output to the motor driver (IC551)
89	SPDV	O	Spindle motor drive control signal output (V) to the motor driver (IC551)
90	SPDW	O	Spindle motor drive control signal output (W) to the motor driver (IC551)
91	DSPVDD2	—	Power supply terminal (for DSP block) (+1.5V)
92	DSPVSS1	—	Ground terminal (for DSP block)

Pin No.	Pin Name	I/O	Description
93	SPCU	I	Spindle motor drive comparison signal input (U) from the motor driver (IC551)
94	SPCV	I	Spindle motor drive comparison signal input (V) from the motor driver (IC551)
95	SPCW	I	Spindle motor drive comparison signal input (W) from the motor driver (IC551)
96	SRDR	O	Sled motor drive signal output (U) to the motor driver (IC551)
97	SFDR	O	Sled servo drive PWM signal output to the motor driver (IC551)
98	SLDV	O	Sled motor drive signal output (V) to the motor driver (IC551)
99	SLDW	O	Sled motor drive signal output (W) to the motor driver (IC551)
100	SLCU	I	Sled motor drive comparison signal input (U) from the motor driver (IC551)
101	SLCV	I	Sled motor drive comparison signal input (V) from the motor driver (IC551)
102	SLCW	I	Sled motor drive comparison signal input (W) from the motor driver (IC551)
103	DIFVDD1	—	Power supply terminal (for DSP I/F) (+2.3V)
104	DIFVSS1	—	Ground terminal (for DSP I/F)
105	EFMO	O	EFM encode data output for the record to the over write head drive (IC601)
106	MNT0	O	Internal DSP monitor output (0) terminal Not used (open)
107	MNT1	O	Internal DSP monitor output (1) terminal Not used (open)
108	MNT2	O	Internal DSP monitor output (2) terminal Not used (open)
109	MNT3	O	Internal DSP monitor output (3) terminal Not used (open)
110	SENSE	O	Internal DSP (SENS) monitor output terminal Not used (open)
111	TX	O	Record data output enable signal output monitor terminal of the internal DSP Not used (open)
112	RECP	O	Laser power changeover signal output monitor terminal Not used (open)
113	DSPVDD3	—	Power supply terminal (for DSP block) (+1.5V)
114 to 117	NC	O	Output terminal for the external D-RAM Not used (open)
118	DRAMVSS0	—	Ground terminal (for the external D-RAM)
119	DRAMVDD0	—	Power supply terminal (for the external D-RAM) (+2.4V)
120 to 138	NC	O	Output terminal for the external D-RAM Not used (open)
139	DRAMVDD1	—	Power supply terminal (for the external D-RAM) (+2.4V)
140	DRAMVSS1	—	Ground terminal (for the external D-RAM)
141	TSB MST VDD	—	Power supply terminal (for TSB master communication) (+2.8V)
142	RMC DTCK	I/O	TSB serial data input/output with the remote commander attached headphone
143	TSB SLV VDD	—	Power supply terminal (for I/F to TSB slave communication)
144	TSB SLVI	I	TSB slave signal input from the remote commander attached headphone
145	TSB SLVO	O	TSB slave signal output to the remote commander attached headphone
146	TDI	I	Data input terminal for JTAG Not used (open)
147	TMS	I	Test mode control input terminal for JTAG Not used (open)
148	TCK	I	Clock input terminal for JTAG Not used (open)
149	XTRST	I	Reset input terminal for JTAG Not used (open)
150	TDO	O	Data output terminal for JTAG Not used (open)
151	JTAGVDD	—	Power supply terminal (for JTAG) (+2.4V)
152	JTAGVSS	—	Ground terminal (for JTAG)
153	MCUVDD2	—	Power supply terminal (for the microcomputer block) (+1.5V)
154	MIFVDD0	—	Power supply terminal (for the microcomputer I/F block) (+2.3V)
155	MIFVSS0	—	Ground terminal (for the microcomputer I/F block)
156, 157	TEST1, TEST0	I	Input terminal for the main test (normally fixed at "L")

Pin No.	Pin Name	I/O	Description
158	EVA	I	EVA/FLASH chip discrimination terminal "L": FLASH chip, "H": EVA chip
159	OPR LED	—	Not used (open)
160	SSB DATA	I/O	Input/output of SSB data with RF amp (IC501)
161	SSB CLK	O	SSB clock output to RF amp (IC501)
162	MCUVSS0	—	Ground terminal (for the microcomputer block)
163	VREC PWM	O	Over write head control spare terminal Not used (open)
164	VL PWM	O	PWM signal output for the laser power supply voltage control to the power control (IC901)
165	VC PWM	O	PWM signal output for the system power supply voltage control to the power control (IC901)
166	SPDL AUX PWM	O	PWM signal output for the spindle support to the motor driver (IC551)
167, 168	NC	O	Not used (open)
169	CLK SEL	O	System clock select signal output to the power control (IC901)
170	OPEN CLOSE SW	I	Open/close detection switch (S806) of the upper panel input terminal "L": when upper panel close
171	NC	O	Not used (open)
172	SET CODE0	I	Input terminal for the set (fixed at "L" in this set)
173	SET CODE1	I	Input terminal for the set (open in this set)
174, 175	SET CODE2, 3	I	Input terminal for the set (fixed at "L" in this set)
176	MIFVDD1	—	Power supply terminal (for the microcomputer I/F block) (+2.3V)
177	MIFVSS1	—	Ground terminal (for the microcomputer I/F block)
178	AOUT SEL	O	HP/LINE changeover signal output to the headphone amp (IC302)
179	SI0	I	Serial data input from the nonvolatile memory (IC804) and liquid crystal display element module
180	SO0	O	Serial data output to the nonvolatile memory (IC804), A/D converter (IC301) and liquid crystal display element module
181	SCK0	O	Serial clock signal output to the nonvolatile memory (IC804), A/D converter (IC301) and liquid crystal display element module
182	XGUM ON	I	Rechargeable battery detection switch (S804) input terminal "L": there is rechargeable battery
183	BEEP	O	Beep sound control signal output to the headphone amp (IC302)
184	NC	O	Not used (open)
185	VD SEL	O	VD power supply changeover signal output terminal Not used (open)
186	XMUTE	O	Analog muting control signal output terminal to the headphone amp (IC302) "L": muting ON
187	LCD RST AUX	O	Reset control signal output terminal to the liquid crystal display element "L": reset
188	PAUSE KEY	I	Pause key input terminal from the switch & LCD module
189	MIC SENSE	O	Mic sense control signal output to the mic amp (IC303) "L": Low sensitivity "H": High sensitivity
190	XPATCH	I	Patch function detection input terminal "L": patch function Not used (open)
191	OPT DET	I	DIN plug detection signal input terminal
192	XJACK DET	I	LINE IN plug detection signal input terminal
193	XMIC DET	I	Microphone plug detection signal input terminal
194, 195	PD S0, PD S1	O	PD IC mode changeover signal output to the optical pick up
196	MIFVDD2	—	Power supply terminal (for the microcomputer I/F block) (+2.3V)

Pin No.	Pin Name	I/O	Description
197 to 199	MODE1 to 3	O	Power supply control signal output (for the over write head drive) to the over write head drive (IC601)
200, 201	HD CON 1, 2	O	Over write head control signal output to the over write head drive (IC601)
202	XTEST	I	Terminal for test mode set (nomally: open) "L": test mode
203	XCS ADA	O	Chip select signal output to A/D converter (IC301)
204	XPD ADA	O	Power supply control signal output for the drive to A/D converter (IC301)
205	XCS LCD	O	Chip select signal output to the liquid crystal display element
206	LCD STB	O	Strobe signal output to the liquid crystal display element
207	LCD RST	O	Reset control signal output to the liquid crystal display element Not used (open)
208	REC LED	O	LED ON/OFF control signal output for REC display
209	LD ON	O	ON/OFF control signal output terminal of the laser diode Not used (open)
210	TSB SLV CHK	O	TSB slave detection signal output terminal
211	K-TAI MON	—	Not used (open)
212	K-TAI SW	—	Not used (open)
213	MCUVSS1	—	Ground terminal (for the microcomputer block)
214	GND SW	O	GND changeover control signal output
215	XOPT CTL	O	Power supply ON/OFF control signal output for DIN PD drive
216	CS RTC	O	Chip select signal output to the clock IC
217	OFTRK	O	Off track signal output to RF amp (IC501)
218	MUTE	O	Analog muting control signal output "H": muting ON Not used (open)
219	XCS NV	O	Chip select signal output to EEPROM (IC804)
220	XRST MTR DRV	O	Reset control signal output to the motor driver (IC551)
221	XRF RST	O	Reset control signal output to RF amp (IC501)
222	MCUVDD3	—	Power supply terminal (for the microcomputer block) (+1.5V)
223	SPDL MON	I	Spindle servo monitor signal input from the motor driver (IC551)
224	XAVLS	I	Input terminal for AVLS switch detection signal
225, 226	JOG A, B	I	Jog dial pulse input terminal from the switch & LCD module
227	XHOLD SW	I	HOLD switch (S801) input terminal "L": hold ON, "H": hold OFF
228	SYNC REC	I	SYNCHRO REC switch (S802) input terminal "L": OFF, "H": ON Not used (open)
229	TSB SSB CTL	O	TSB/SSB changeover control signal output Not used (open)
230	PROTECT	I	Detection input terminal of the record check claw from the protect detection switch (S803) "L": recording possible condition, "H": protect
231	FLASHVDD	—	Power supply terminal (for the internal FLASH ROM) (+2.4V)
232	FLASHVSS	—	Ground terminal (for the internal FLASH ROM)
233	SLD MON	I	Sled servo monitor signal input from the motor driver (IC551)
234	VLON	O	Power supply control signal output for the laser diode drive to the power control (IC901)
235	SLEEP	O	System sleep control signal output to the power control (IC901) "H": sleep ON
236	FFCLR	O	Input latch output for the start switching to the power control (IC901)
237	CHG GAIN	O	Charge gain control signal output to the power control (IC601)
238	CHG	O	Charge ON/OFF control signal output to the power control (IC601) "H": charge ON
239	TUN REG ON	O	Not used (open)
240	XHP STBY	O	Power supply control signal output terminal for the headphone amp Not used (open)
241	MIFVDD3	—	Power supply terminal (for the microcomputer I/F block) (+2.3V)
242	MIFVSS2	—	Ground terminal (for the microcomputer I/F block)
243	TEST2	I	Input terminal for the main test (normally open)
244	NC	—	Not used (open)

SECTION 7 EXPLODED VIEWS

NOTE:

- -XX and -X mean standardized parts, so they may have some difference from the original one.
- Color Indication of Appearance Parts
Example:
KNOB, BALANCE (WHITE) . . . (RED)

↑

↑

 Parts Color Cabinet's Color
- Abbreviation
HK : Hong Kong model
JEW : Tourist model

- Items marked “*” are not stocked since they are seldom required for routine service. Some delay should be anticipated when ordering these items.
- The mechanical parts with no reference number in the exploded views are not supplied.
- Accessories and packing materials are given in the last of the electrical parts list.

The components identified by mark Δ or dotted line with mark Δ are critical for safety. Replace only with part number specified.

7-1. PANEL SECTION

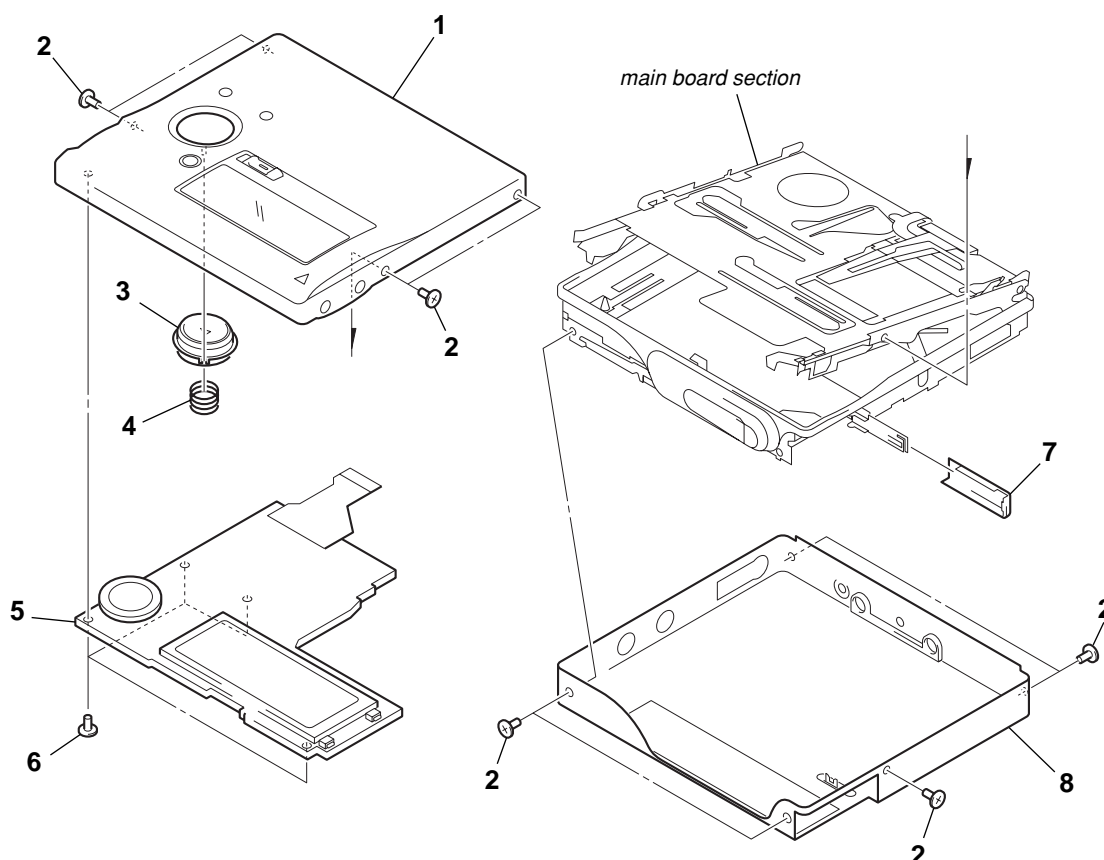

<u>Ref. No.</u>	<u>Part No.</u>	<u>Description</u>	<u>Remark</u>	<u>Ref. No.</u>	<u>Part No.</u>	<u>Description</u>	<u>Remark</u>
1	X-3381-080-1	SERVICE ASSY, UPPER PANEL (R) (RED)		7	3-220-484-01	LID, BATTERY CASE (SILVER)	
1	X-3381-083-1	SERVICE ASSY, UPPER PANEL (S) (SILVER)		7	3-220-484-11	LID, BATTERY CASE (BLUE)	
1	X-3381-084-1	SERVICE ASSY, UPPER PANEL (L) (BLUE)		7	3-220-484-21	LID, BATTERY CASE (RED)	
2	3-225-873-09	SCREW, ES LOCK		8	X-3380-976-1	PANEL (S) ASSY, BOTTOM (SILVER) (JEW)	
3	3-233-933-01	BUTTON (5 POINT)		8	X-3380-977-1	PANEL (L) ASSY, BOTTOM (BLUE) (JEW)	
4	3-233-934-01	SPRING, COMPRESSION		8	X-3380-979-1	PANEL (S) ASSY, BOTTOM (SILVER) (E, HK)	
5	1-804-488-11	LCD MODULE		8	X-3380-980-1	PANEL (L) ASSY, BOTTOM (BLUE) (E, HK)	
6	4-984-017-01	SCREW (1.7), TAPPING		8	X-3380-981-1	PANEL (R) ASSY, BOTTOM (RED)	

7-2. CHASSIS SECTION

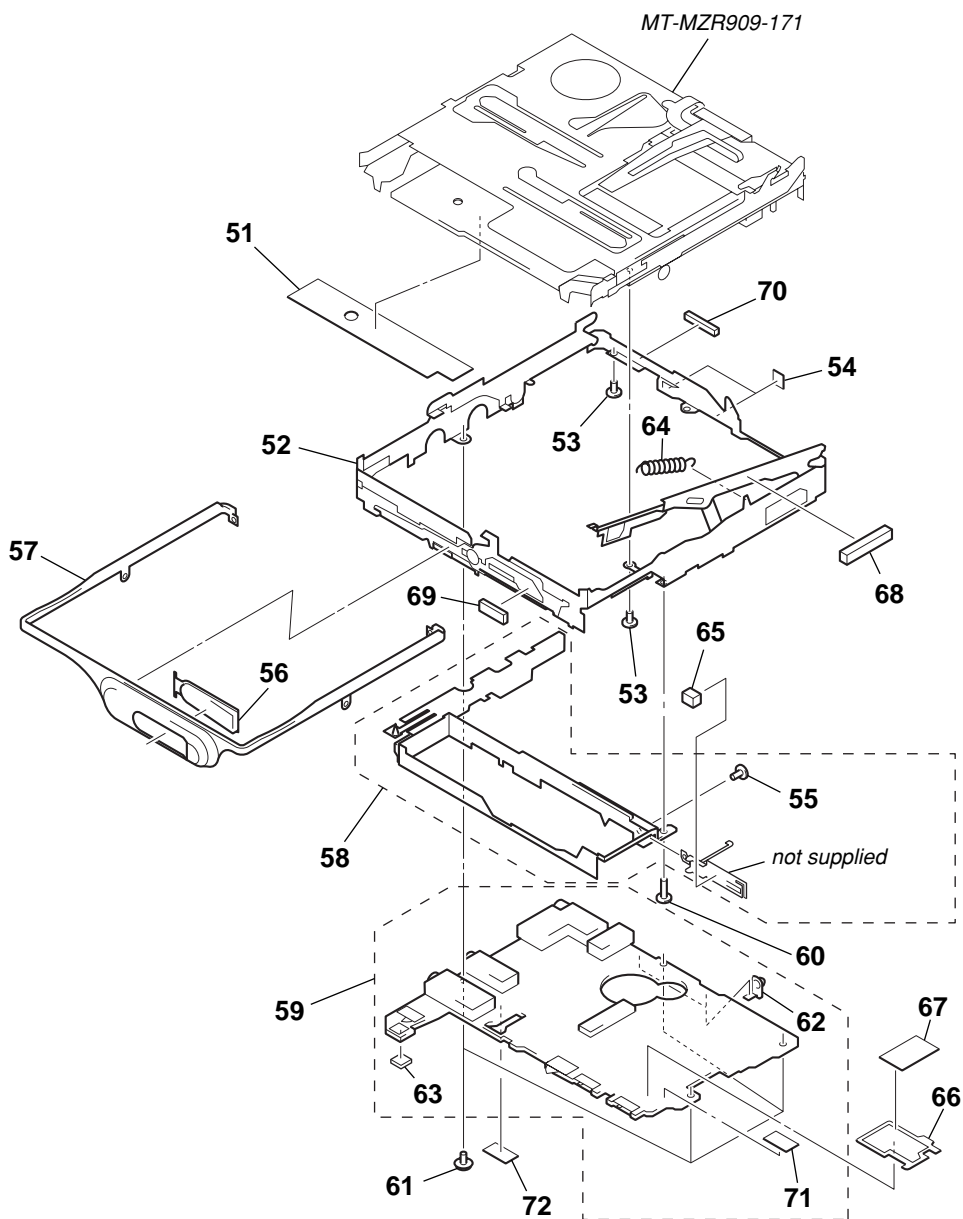

Ref. No.	Part No.	Description	Remark	Ref. No.	Part No.	Description	Remark
51	3-220-477-01	SHEET (MD), INSULATING		61	3-335-797-91	SCREW (M1.4), TOOTHED LOCK	
52	X-3379-320-1	CHASSIS ASSY, SET		62	4-223-110-01	TERMINAL (3)	
53	3-225-996-04	SCREW (M1.4) (EG), PRECISION PAN		63	3-226-169-01	SPACER (PRO)	
54	3-224-089-01	SHEET (TERMINAL), INSULATING		64	3-220-471-01	SPRING (ARM), TENSION	
55	4-218-229-25	SCREW (1.4), MI		65	3-235-763-01	SHEET (PLUS)	
56	3-220-465-01	BUTTON (OPEN)		66	3-235-461-01	SHEET (SHIELD)	
57	3-220-464-01	STRIP, ORNAMENTAL (SILVER)...(SILVER)		67	3-235-804-01	SHEET (OP)	
57	3-220-464-11	STRIP, ORNAMENTAL (DARK SILVER)...(BLUE, RED)		68	3-226-758-01	SPACER (FULCRUM PLATE R2)	
58	X-3379-321-2	CASE ASSY, BATTERY		69	3-237-214-01	SHEET (OPEN)	
* 59	A-3021-532-A	MAIN BOARD, COMPLETE		70	3-226-168-01	SPACER (REAR) (2)	
60	3-225-873-29	SCREW, ES LOCK		71	3-236-624-01	SHEET (SHIELD) B	
				72	3-226-167-01	SPACER (LINE IN)	

7-3. MD MECHANISM DECK SECTION
(MT-MZR909-171)

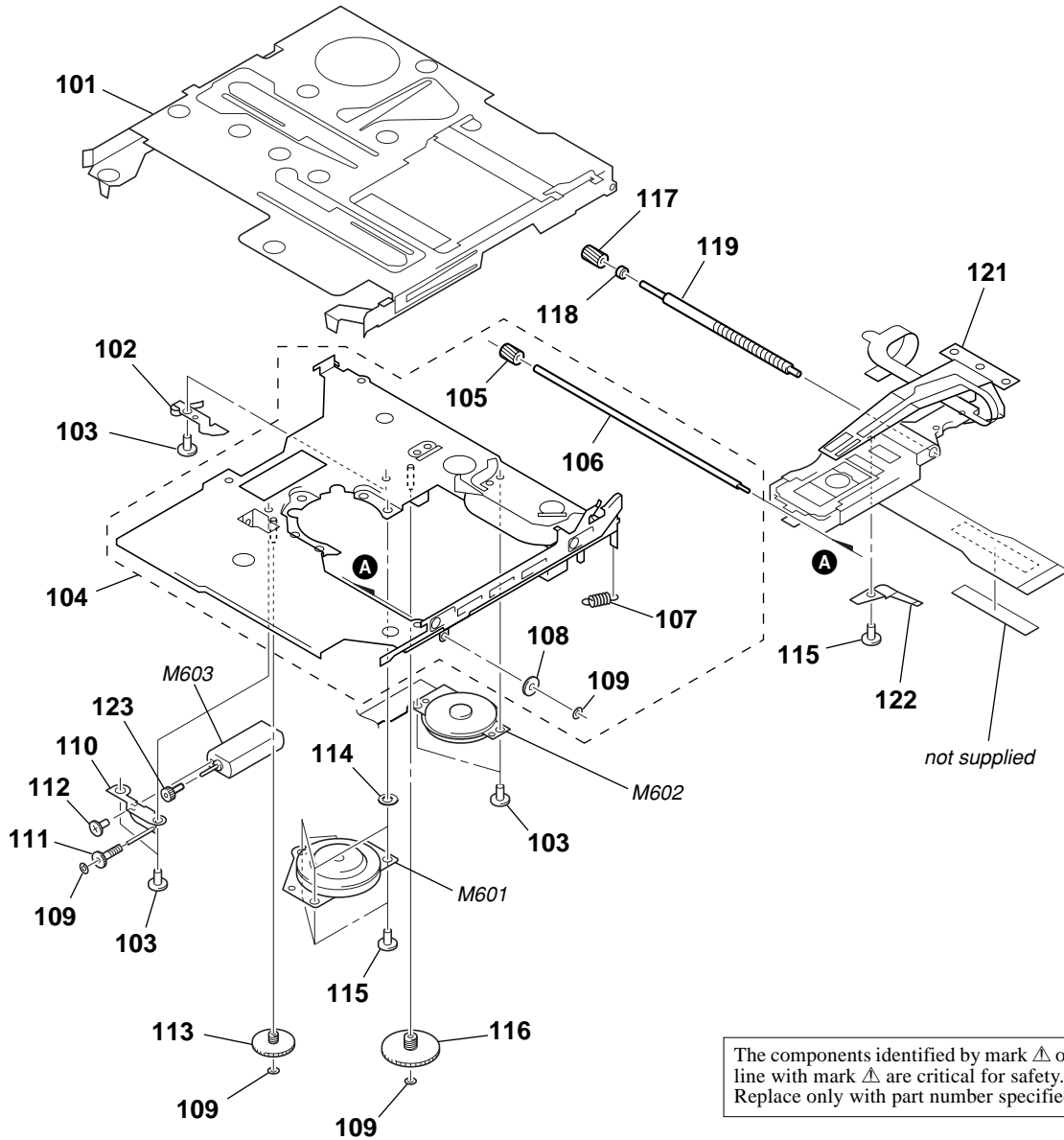

Ref. No.	Part No.	Description	Remark	Ref. No.	Part No.	Description	Remark
101	X-3379-498-1	HOLDER ASSY		115	3-225-996-06	SCREW (M1.4) (EG), PRECISION PAN	
102	3-224-779-01	SPRING, THRUST DETENT		116	4-222-216-01	GEAR (SA)	
103	3-225-996-01	SCREW (M1.4) (EG), PRECISION PAN		117	4-222-208-01	GEAR (SB)	
104	X-3379-497-1	CHASSIS ASSY		118	3-043-237-02	BEARING (N)	
105	4-222-218-01	GEAR (HD)		119	4-222-203-01	SCREW, LEAD	
106	4-222-223-01	SHAFT, SUB		120	3-225-137-11	SCREW, PRECISION MACHINE	
107	4-222-226-01	SPRING (EJECT), TENSION		Δ 121	X-3379-508-1	SERVICE ASSY, OP (LCX-4R)	
108	4-222-222-01	GEAR (RACK)		122	4-222-205-11	SPRING, RACK	
109	3-338-645-31	WASHER (0.8-2.5)		123	3-222-544-01	GEAR (HA)	
110	X-4951-918-1	CHASSIS ASSY, GEAR		M601	8-835-744-01	MOTOR, DC SSM18B (SPINDLE) (WITH TURN TABLE)	
111	3-222-545-01	GEAR (HB)		M602	1-763-727-11	MOTOR, DC (SLED) (WITH GEAR)	
112	4-224-885-01	SCREW (M1.2X1.5)		M603	1-763-400-21	MOTOR, DC (OVER WRITE HEAD UP/DOWN)	
113	4-222-215-01	GEAR (HC)					
114	4-997-677-11	WASHER					

SECTION 8 ELECTRICAL PARTS LIST

MAIN

NOTE:

- Due to standardization, replacements in the parts list may be different from the parts specified in the diagrams or the components used on the set.
- -XX and -X mean standardized parts, so they may have some difference from the original one.
- RESISTORS
All resistors are in ohms.
METAL: Metal-film resistor.
METAL OXIDE: Metal oxide-film resistor.
F: nonflammable
- Abbreviation
HK : Hong Kong model
JEW : Tourist model

- Items marked “*” are not stocked since they are seldom required for routine service. Some delay should be anticipated when ordering these items.
- SEMICONDUCTORS
In each case, u: μ , for example:
uA. . : μ A. . uPA. . : μ PA. .
uPB. . : μ PB. . uPC. . : μ PC. .
uPD. . : μ PD. .
- CAPACITORS
uF: μ F
- COILS
uH: μ H

The components identified by mark Δ or dotted line with mark Δ are critical for safety. Replace only with part number specified.

When indicating parts by reference number, please include the board.

Ref. No.	Part No.	Description	Remark	Ref. No.	Part No.	Description	Remark
*	A-3021-532-A	MAIN BOARD, COMPLETE *****		C314	1-119-923-11	CERAMIC CHIP 0.047uF	10% 10V
	3-226-169-01	SPACER (PRO)		C315	1-127-578-11	TANTALUM CHIP 3.3uF	20% 6.3V
	3-236-624-01	SHEET (SHIELD) B		C316	1-125-926-11	TANTALUM CHIP 4.7uF	20% 6.3V
	4-223-110-01	TERMINAL (3)		C318	1-125-777-11	CERAMIC CHIP 0.1uF	10% 10V
		< CAPACITOR >		C320	1-117-919-11	TANTALUM CHIP 10uF	20% 6.3V
C101	1-125-837-11	CERAMIC CHIP 1uF	10% 6.3V	C321	1-125-777-11	CERAMIC CHIP 0.1uF	10% 10V
C102	1-164-942-11	CERAMIC CHIP 0.0068uF	10% 16V	C322	1-131-862-11	TANTALUM CHIP 47uF	20% 4V
C104	1-135-868-11	TANTALUM CHIP 220uF	20% 2.5V	C323	1-117-919-11	TANTALUM CHIP 10uF	20% 6.3V
C105	1-113-600-11	TANTALUM CHIP 2.2uF	20% 6.3V	C329	1-125-777-11	CERAMIC CHIP 0.1uF	10% 10V
C107	1-164-943-11	CERAMIC CHIP 0.01uF	10% 16V	C330	1-107-820-11	CERAMIC CHIP 0.1uF	16V
C110	1-125-837-11	CERAMIC CHIP 1uF	10% 6.3V	C332	1-117-919-11	TANTALUM CHIP 10uF	20% 6.3V
C111	1-164-874-11	CERAMIC CHIP 100PF	5% 16V	C335	1-164-933-11	CERAMIC CHIP 220PF	10% 16V
C112	1-125-837-11	CERAMIC CHIP 1uF	10% 6.3V	C336	1-125-837-11	CERAMIC CHIP 1uF	10% 6.3V
C113	1-131-862-11	TANTALUM CHIP 47uF	20% 4V	C337	1-117-863-11	CERAMIC CHIP 0.47uF	10% 6.3V
C116	1-164-937-11	CERAMIC CHIP 0.001uF	10% 16V	C338	1-164-874-11	CERAMIC CHIP 100PF	5% 16V
C117	1-125-777-11	CERAMIC CHIP 0.1uF	10% 10V	C340	1-125-777-11	CERAMIC CHIP 0.1uF	10% 10V
C118	1-164-939-11	CERAMIC CHIP 0.0022uF	10% 16V	C344	1-164-943-11	CERAMIC CHIP 0.01uF	10% 16V
C201	1-125-837-11	CERAMIC CHIP 1uF	10% 6.3V	C501	1-164-874-11	CERAMIC CHIP 100PF	5% 16V
C202	1-164-942-11	CERAMIC CHIP 0.0068uF	10% 16V	C502	1-127-772-11	CERAMIC CHIP 33000PF	10% 10V
C204	1-135-868-11	TANTALUM CHIP 220uF	20% 2.5V	C503	1-164-940-11	CERAMIC CHIP 0.0033uF	10% 16V
C205	1-113-600-11	TANTALUM CHIP 2.2uF	20% 6.3V	C504	1-164-940-11	CERAMIC CHIP 0.0033uF	10% 16V
C207	1-164-943-11	CERAMIC CHIP 0.01uF	10% 16V	C505	1-164-943-11	CERAMIC CHIP 0.01uF	10% 16V
C210	1-125-837-11	CERAMIC CHIP 1uF	10% 6.3V	C506	1-127-772-11	CERAMIC CHIP 33000PF	10% 10V
C211	1-164-874-11	CERAMIC CHIP 100PF	5% 16V	C507	1-127-772-11	CERAMIC CHIP 33000PF	10% 10V
C212	1-125-837-11	CERAMIC CHIP 1uF	10% 6.3V	C508	1-125-777-11	CERAMIC CHIP 0.1uF	10% 10V
C213	1-131-862-11	TANTALUM CHIP 47uF	20% 4V	C509	1-164-940-11	CERAMIC CHIP 0.0033uF	10% 16V
C216	1-164-937-11	CERAMIC CHIP 0.001uF	10% 16V	C510	1-164-850-11	CERAMIC CHIP 10PF	0.5PF 16V
C217	1-125-777-11	CERAMIC CHIP 0.1uF	10% 10V	C511	1-164-850-11	CERAMIC CHIP 10PF	0.5PF 16V
C218	1-164-939-11	CERAMIC CHIP 0.0022uF	10% 16V	C512	1-125-777-11	CERAMIC CHIP 0.1uF	10% 10V
C301	1-125-839-11	TANTALUM CHIP 47uF	20% 6.3V	C513	1-164-850-11	CERAMIC CHIP 10PF	0.5PF 16V
C302	1-107-820-11	CERAMIC CHIP 0.1uF	16V	C514	1-107-819-11	CERAMIC CHIP 0.022uF	10% 16V
C303	1-117-919-11	TANTALUM CHIP 10uF	20% 6.3V	C515	1-125-777-11	CERAMIC CHIP 0.1uF	10% 10V
C304	1-125-777-11	CERAMIC CHIP 0.1uF	10% 10V	C516	1-125-777-11	CERAMIC CHIP 0.1uF	10% 10V
C305	1-113-600-11	TANTALUM CHIP 2.2uF	20% 6.3V	C518	1-125-926-11	TANTALUM CHIP 4.7uF	20% 6.3V
C306	1-107-820-11	CERAMIC CHIP 0.1uF	16V	C519	1-164-940-11	CERAMIC CHIP 0.0033uF	10% 16V
C308	1-107-820-11	CERAMIC CHIP 0.1uF	16V	C521	1-125-777-11	CERAMIC CHIP 0.1uF	10% 10V
C309	1-127-895-11	TANTALUM CHIP 22uF	20% 4V	C522	1-125-777-11	CERAMIC CHIP 0.1uF	10% 10V
C310	1-125-899-11	TANTALUM CHIP 220uF	20% 4V	C523	1-125-837-11	CERAMIC CHIP 1uF	10% 6.3V
C311	1-128-964-11	TANTALUM CHIP 100uF	20% 6.3V	C524	1-117-919-11	TANTALUM CHIP 10uF	20% 6.3V
C312	1-127-895-11	TANTALUM CHIP 22uF	20% 4V	C526	1-125-777-11	CERAMIC CHIP 0.1uF	10% 10V
C313	1-127-895-11	TANTALUM CHIP 22uF	20% 4V	C529	1-125-840-11	TANTALUM 10uF	20% 6.3V
				C530	1-164-939-11	CERAMIC CHIP 0.0022uF	10% 16V
				C532	1-119-923-11	CERAMIC CHIP 0.047uF	10% 10V
				C557	1-127-772-11	CERAMIC CHIP 33000PF	10% 10V

MAIN

Ref. No.	Part No.	Description	Remark	Ref. No.	Part No.	Description	Remark
C558	1-127-772-11	CERAMIC CHIP 33000PF	10% 10V	C825	1-125-777-11	CERAMIC CHIP 0.1uF	10% 10V
C559	1-127-772-11	CERAMIC CHIP 33000PF	10% 10V	C826	1-127-715-11	CERAMIC CHIP 0.22uF	10% 16V
C561	1-125-777-11	CERAMIC CHIP 0.1uF	10% 10V	C827	1-164-850-11	CERAMIC CHIP 10PF	0.5PF 16V
C562	1-127-772-11	CERAMIC CHIP 33000PF	10% 10V	C830	1-117-919-11	TANTALUM CHIP 10uF	20% 6.3V
C563	1-127-772-11	CERAMIC CHIP 33000PF	10% 10V	C831	1-128-964-11	TANTALUM CHIP 100uF	20% 6.3V
C564	1-127-772-11	CERAMIC CHIP 33000PF	10% 10V	C832	1-107-820-11	CERAMIC CHIP 0.1uF	16V
C566	1-125-777-11	CERAMIC CHIP 0.1uF	10% 10V	C833	1-164-874-11	CERAMIC CHIP 100PF	5% 16V
C601	1-164-943-11	CERAMIC CHIP 0.01uF	10% 16V	C834	1-125-777-11	CERAMIC CHIP 0.1uF	10% 10V
C602	1-125-777-11	CERAMIC CHIP 0.1uF	10% 10V	C835	1-125-777-11	CERAMIC CHIP 0.1uF	10% 10V
C603	1-125-839-11	TANTALUM CHIP 47uF	20% 6.3V	C836	1-125-777-11	CERAMIC CHIP 0.1uF	10% 10V
C604	1-164-943-11	CERAMIC CHIP 0.01uF	10% 16V	C837	1-125-777-11	CERAMIC CHIP 0.1uF	10% 10V
C605	1-164-937-11	CERAMIC CHIP 0.001uF	10% 16V	C838	1-117-919-11	TANTALUM CHIP 10uF	20% 6.3V
C606	1-164-874-11	CERAMIC CHIP 100PF	5% 16V	C839	1-164-943-11	CERAMIC CHIP 0.01uF	10% 16V
C607	1-164-874-11	CERAMIC CHIP 100PF	5% 16V	C842	1-125-777-11	CERAMIC CHIP 0.1uF	10% 10V
C608	1-125-777-11	CERAMIC CHIP 0.1uF	10% 10V	C901	1-125-840-11	TANTALUM 10uF	20% 6.3V
C609	1-137-762-11	TANTALUM 10uF	20% 4V	C902	1-125-840-11	TANTALUM 10uF	20% 6.3V
C610	1-125-777-11	CERAMIC CHIP 0.1uF	10% 10V	C903	1-128-964-11	TANTALUM CHIP 100uF	20% 6.3V
C611	1-117-919-11	TANTALUM CHIP 10uF	20% 6.3V	C904	1-137-762-11	TANTALUM 10uF	20% 4V
C612	1-117-919-11	TANTALUM CHIP 10uF	20% 6.3V	C905	1-125-777-11	CERAMIC CHIP 0.1uF	10% 10V
C613	1-125-777-11	CERAMIC CHIP 0.1uF	10% 10V	C906	1-164-943-11	CERAMIC CHIP 0.01uF	10% 16V
C614	1-125-777-11	CERAMIC CHIP 0.1uF	10% 10V	C907	1-125-889-11	CERAMIC CHIP 2.2uF	10% 10V
C615	1-137-760-11	CAP-CHIP 100PF	5% 100V	C908	1-125-777-11	CERAMIC CHIP 0.1uF	10% 10V
C616	1-125-777-11	CERAMIC CHIP 0.1uF	10% 10V	C911	1-117-919-11	TANTALUM CHIP 10uF	20% 6.3V
C618	1-125-777-11	CERAMIC CHIP 0.1uF	10% 10V	C913	1-164-941-11	CERAMIC CHIP 0.0047uF	10% 16V
C619	1-125-777-11	CERAMIC CHIP 0.1uF	10% 10V	C914	1-125-777-11	CERAMIC CHIP 0.1uF	10% 10V
C621	1-164-943-11	CERAMIC CHIP 0.01uF	10% 16V	C915	1-125-777-11	CERAMIC CHIP 0.1uF	10% 10V
C623	1-127-895-11	TANTALUM CHIP 22uF	20% 4V	C917	1-125-777-11	CERAMIC CHIP 0.1uF	10% 10V
C624	1-127-895-11	TANTALUM CHIP 22uF	20% 4V	C919	1-117-919-11	TANTALUM CHIP 10uF	20% 6.3V
C625	1-131-862-11	TANTALUM CHIP 47uF	20% 4V	C920	1-117-919-11	TANTALUM CHIP 10uF	20% 6.3V
C626	1-125-839-11	TANTALUM CHIP 47uF	20% 6.3V	C921	1-125-777-11	CERAMIC CHIP 0.1uF	10% 10V
C629	1-164-943-11	CERAMIC CHIP 0.01uF	10% 16V	C922	1-164-937-11	CERAMIC CHIP 0.001uF	10% 16V
C630	1-164-874-11	CERAMIC CHIP 100PF	5% 16V	C923	1-125-891-11	CERAMIC CHIP 0.47uF	10% 10V
C631	1-117-919-11	TANTALUM CHIP 10uF	20% 6.3V	C924	1-125-891-11	CERAMIC CHIP 0.47uF	10% 10V
C633	1-125-777-11	CERAMIC CHIP 0.1uF	10% 10V	C925	1-125-891-11	CERAMIC CHIP 0.47uF	10% 10V
C801	1-125-777-11	CERAMIC CHIP 0.1uF	10% 10V	C926	1-164-937-11	CERAMIC CHIP 0.001uF	10% 16V
C802	1-164-943-11	CERAMIC CHIP 0.01uF	10% 16V	C932	1-125-777-11	CERAMIC CHIP 0.1uF	10% 10V
C803	1-164-943-11	CERAMIC CHIP 0.01uF	10% 16V	< CONNECTOR >			
C804	1-125-777-11	CERAMIC CHIP 0.1uF	10% 10V	* CN501	1-778-168-11	CONNECTOR, FFC/FPC (ZIF) 20P	
C805	1-119-923-11	CERAMIC CHIP 0.047uF	10% 10V	* CN502	1-815-790-21	CONNECTOR, FPC (ZIF) 10P	
C806	1-119-923-11	CERAMIC CHIP 0.047uF	10% 10V	* CN801	1-815-791-21	CONNECTOR, FPC (ZIF) 19P	
C807	1-164-850-11	CERAMIC CHIP 10PF	0.5PF 16V	< DIODE >			
C808	1-164-850-11	CERAMIC CHIP 10PF	0.5PF 16V	D301	8-719-081-74	DIODE DF8A6.8FK (TE85R)	
C809	1-125-840-11	TANTALUM 10uF	20% 6.3V	D302	8-719-081-73	DIODE DF3A6.8FE (TPL3)	
C810	1-125-837-11	CERAMIC CHIP 1uF	10% 6.3V	D303	8-719-056-23	DIODE MA2S111- (K8).SO	
C811	1-125-837-11	CERAMIC CHIP 1uF	10% 6.3V	D601	8-719-081-33	DIODE MA2YD1500LS0	
C812	1-164-943-11	CERAMIC CHIP 0.01uF	10% 16V	D602	8-719-081-33	DIODE MA2YD1500LS0	
C813	1-125-891-11	CERAMIC CHIP 0.47uF	10% 10V	D603	8-719-081-34	DIODE RB160M-30TR	
C814	1-164-935-11	CERAMIC CHIP 470PF	10% 16V	D605	8-719-081-34	DIODE RB160M-30TR	
C815	1-125-839-11	TANTALUM CHIP 47uF	20% 6.3V	D606	8-719-081-35	DIODE MA2YD1700LS0	
C816	1-125-777-11	CERAMIC CHIP 0.1uF	10% 10V	D607	8-719-081-33	DIODE MA2YD1500LS0	
C817	1-125-837-11	CERAMIC CHIP 1uF	10% 6.3V	D608	8-719-081-35	DIODE MA2YD1700LS0	
C818	1-125-777-11	CERAMIC CHIP 0.1uF	10% 10V	D801	8-719-056-54	DIODE MAZS068008SO	
C819	1-127-772-11	CERAMIC CHIP 33000PF	10% 10V	D901	8-719-081-33	DIODE MA2YD1500LS0	
C820	1-127-772-11	CERAMIC CHIP 33000PF	10% 10V	D902	8-719-081-33	DIODE MA2YD1500LS0	
C821	1-117-919-11	TANTALUM CHIP 10uF	20% 6.3V	D903	8-719-420-51	DIODE MA729-TX	
C822	1-125-777-11	CERAMIC CHIP 0.1uF	10% 10V	D904	8-719-073-01	DIODE MA111-TX	
C823	1-107-820-11	CERAMIC CHIP 0.1uF	16V				

Ref. No.	Part No.	Description	Remark	Ref. No.	Part No.	Description	Remark
		< FUSE >		Q605	8-729-046-42	FET	HAT2050T-EL
				Q801	8-729-429-44	TRANSISTOR	XP1501-TXE
△F801	1-576-439-21	FUSE (SMD) (0.25A/125V)		Q803	8-729-029-14	TRANSISTOR	DTC144EUA-T106
		< RESISTOR >					
FB301	1-216-864-11	METAL CHIP	0 5% 1/16W	R101	1-208-703-11	METAL CHIP	6.8K 0.5% 1/16W
FB302	1-216-864-11	METAL CHIP	0 5% 1/16W	R103	1-218-965-11	RES-CHIP	10K 5% 1/16W
FB303	1-216-809-11	METAL CHIP	100 5% 1/16W	R104	1-218-990-11	SHORT	0
FB304	1-216-809-11	METAL CHIP	100 5% 1/16W	R105	1-208-643-11	RES-CHIP	22 5% 1/16W
FB305	1-216-864-11	METAL CHIP	0 5% 1/16W	R111	1-208-715-11	METAL CHIP	22K 0.5% 1/16W
FB306	1-216-864-11	METAL CHIP	0 5% 1/16W	R112	1-208-927-11	METAL CHIP	47K 0.5% 1/16W
FB801	1-216-864-11	METAL CHIP	0 5% 1/16W	R118	1-208-703-11	METAL CHIP	6.8K 0.5% 1/16W
FB802	1-216-864-11	METAL CHIP	0 5% 1/16W	R201	1-208-703-11	METAL CHIP	6.8K 0.5% 1/16W
FB803	1-216-864-11	METAL CHIP	0 5% 1/16W	R203	1-218-965-11	RES-CHIP	10K 5% 1/16W
		< IC >		R204	1-218-990-11	SHORT	0
IC301	8-759-694-88	IC AK5354VT-E2		R205	1-208-643-11	RES-CHIP	22 5% 1/16W
IC302	6-700-662-01	IC AN17020A-VB		R211	1-208-715-11	METAL CHIP	22K 0.5% 1/16W
IC303	8-759-699-54	IC NJM2173APC1 (TE2)		R212	1-208-927-11	METAL CHIP	47K 0.5% 1/16W
IC501	8-759-689-67	IC SN761057DBT		R218	1-208-703-11	METAL CHIP	6.8K 0.5% 1/16W
IC551	6-700-680-01	IC SC111258FCR2		R301	1-208-707-11	METAL CHIP	10K 0.5% 1/16W
IC601	8-759-698-60	IC XPC18A22FCR2		R302	1-218-953-11	RES-CHIP	1K 5% 1/16W
@ IC801	8-752-413-14	IC CXD2671-206GA		R303	1-218-983-11	RES-CHIP	330K 5% 1/16W
IC804	8-759-680-85	IC AK6417AL-L		R304	1-218-953-11	RES-CHIP	1K 5% 1/16W
IC805	8-759-196-97	IC TC7SH32FU-TE85R		R305	1-218-953-11	RES-CHIP	1K 5% 1/16W
IC901	8-759-698-61	IC XPC18A32FCR2		R306	1-218-985-11	RES-CHIP	470K 5% 1/16W
		< JACK >		R307	1-218-941-11	RES-CHIP	100 5% 1/16W
J301	1-793-619-21	JACK (LINE IN (OPT))		R309	1-208-943-11	METAL CHIP	220K 0.5% 1/16W
J302	1-793-509-11	JACK (⊘/LINE OUT)		R317	1-218-941-11	RES-CHIP	100 5% 1/16W
J303	1-793-620-21	JACK (MIC (PLUG IN POWER))		R318	1-218-941-11	RES-CHIP	100 5% 1/16W
J601	1-785-383-11	JACK, DC (POLARITY UNIFIED TYPE)	(DC IN 3V)	R319	1-218-941-11	RES-CHIP	100 5% 1/16W
		< COIL >		R501	1-218-973-11	RES-CHIP	47K 5% 1/16W
L301	1-469-535-21	INDUCTOR	10uH	R502	1-218-979-11	RES-CHIP	150K 5% 1/16W
L302	1-469-535-21	INDUCTOR	10uH	R505	1-208-703-11	METAL CHIP	6.8K 0.5% 1/16W
L303	1-469-535-21	INDUCTOR	10uH	R507	1-218-953-11	RES-CHIP	1K 5% 1/16W
L501	1-469-535-21	INDUCTOR	10uH	R517	1-208-691-11	METAL CHIP	2.2K 0.5% 1/16W
L502	1-469-535-21	INDUCTOR	10uH	R519	1-218-977-11	RES-CHIP	100K 5% 1/16W
L601	1-419-959-21	INDUCTOR	6.8uH	R521	1-218-446-11	METAL CHIP	1 5% 1/16W
L602	1-469-535-21	INDUCTOR	10uH	R551	1-216-296-11	SHORT	0
L603	1-469-535-21	INDUCTOR	10uH	R552	1-216-296-11	SHORT	0
L801	1-469-535-21	INDUCTOR	10uH	R553	1-216-296-11	SHORT	0
L802	1-469-535-21	INDUCTOR	10uH	R554	1-216-296-11	SHORT	0
L901	1-419-952-21	INDUCTOR	68uH	R601	1-218-989-11	RES-CHIP	1M 5% 1/16W
L902	1-419-949-21	INDUCTOR	22uH	R602	1-218-981-11	RES-CHIP	220K 5% 1/16W
L903	1-469-367-21	INDUCTOR	10uH	R603	1-218-977-11	RES-CHIP	100K 5% 1/16W
L904	1-414-398-11	INDUCTOR	10uH	R604	1-219-724-11	METAL CHIP	1 1% 1/4W
L905	1-469-426-21	INDUCTOR	100uH	R605	1-242-996-11	METAL CHIP	0.68 1% 1/4W
		< TRANSISTOR >		R606	1-218-949-11	RES-CHIP	470 5% 1/16W
Q302	8-729-046-49	FET	FDV304P	R607	1-218-945-11	RES-CHIP	220 5% 1/16W
Q501	8-729-922-10	TRANSISTOR	2SA1577-T106-QR	R608	1-218-983-11	RES-CHIP	330K 5% 1/16W
Q601	8-729-046-45	FET	SI2302DS-T1	R609	1-219-724-11	METAL CHIP	1 1% 1/4W
Q602	8-729-046-44	TRANSISTOR	ZDT6718TA	R610	1-218-990-11	SHORT	0
Q603	8-729-053-71	FET	TS8K1TB	R611	1-218-990-11	SHORT	0
Q604	8-729-046-43	FET	HAT2051T-EL	R613	1-218-957-11	RES-CHIP	2.2K 5% 1/16W
				R619	1-218-990-11	SHORT	0
				R620	1-218-965-11	RES-CHIP	10K 5% 1/16W
				R621	1-218-965-11	RES-CHIP	10K 5% 1/16W
				R622	1-216-797-11	METAL CHIP	10 5% 1/16W
				R801	1-218-981-11	RES-CHIP	220K 5% 1/16W

The components identified by mark △ or dotted line with mark △ are critical for safety. Replace only with part number specified.

@ Replacement of CXD2671-206GA (IC801) used in this set requires a special tool.

MAIN

Ref. No.	Part No.	Description	Remark
R802	1-208-927-11	METAL CHIP 47K	0.5% 1/16W
R803	1-208-927-11	METAL CHIP 47K	0.5% 1/16W
R804	1-218-959-11	RES-CHIP 3.3K	5% 1/16W
R805	1-218-959-11	RES-CHIP 3.3K	5% 1/16W
R806	1-218-951-11	RES-CHIP 680	5% 1/16W
R807	1-208-635-11	RES-CHIP 10	5% 1/16W
R808	1-218-965-11	RES-CHIP 10K	5% 1/16W
R809	1-218-977-11	RES-CHIP 100K	5% 1/16W
R810	1-208-715-11	METAL CHIP 22K	0.5% 1/16W
R811	1-218-983-11	RES-CHIP 330K	5% 1/16W
R812	1-208-939-11	METAL CHIP 150K	0.5% 1/16W
R813	1-218-989-11	RES-CHIP 1M	5% 1/16W
R814	1-208-635-11	RES-CHIP 10	5% 1/16W
R815	1-218-971-11	RES-CHIP 33K	5% 1/16W
R816	1-218-953-11	RES-CHIP 1K	5% 1/16W
R817	1-218-977-11	RES-CHIP 100K	5% 1/16W
R820	1-218-990-11	SHORT 0	
R821	1-218-981-11	RES-CHIP 220K	5% 1/16W
R822	1-218-953-11	RES-CHIP 1K	5% 1/16W
R823	1-218-945-11	RES-CHIP 220	5% 1/16W
R824	1-218-959-11	RES-CHIP 3.3K	5% 1/16W
R825	1-202-974-11	RES-CHIP 3.3M	5% 1/16W
R828	1-208-691-11	METAL CHIP 2.2K	0.5% 1/16W
R829	1-208-691-11	METAL CHIP 2.2K	0.5% 1/16W
R830	1-218-989-11	RES-CHIP 1M	5% 1/16W
R831	1-218-990-11	SHORT 0	
R832	1-218-990-11	SHORT 0	
R833	1-218-990-11	SHORT 0	
R835	1-218-990-11	SHORT 0	
R841	1-216-809-11	METAL CHIP 100	5% 1/16W
R844	1-216-864-11	METAL CHIP 0	5% 1/16W
R846	1-218-941-11	RES-CHIP 100	5% 1/16W
R848	1-218-990-11	SHORT 0	
R850	1-218-990-11	SHORT 0	
R902	1-218-985-11	RES-CHIP 470K	5% 1/16W
R903	1-218-957-11	RES-CHIP 2.2K	5% 1/16W
R905	1-218-957-11	RES-CHIP 2.2K	5% 1/16W
R906	1-218-990-11	SHORT 0	
R907	1-218-985-11	RES-CHIP 470K	5% 1/16W
R908	1-218-977-11	RES-CHIP 100K	5% 1/16W
R909	1-218-965-11	RES-CHIP 10K	5% 1/16W
R910	1-218-965-11	RES-CHIP 10K	5% 1/16W
R911	1-218-949-11	RES-CHIP 470	5% 1/16W
R915	1-218-941-11	RES-CHIP 100	5% 1/16W
R917	1-218-990-11	SHORT 0	
R920	1-208-707-11	METAL CHIP 10K	0.5% 1/16W
R921	1-218-979-11	RES-CHIP 150K	5% 1/16W
R926	1-208-699-11	METAL CHIP 4.7K	0.5% 1/16W
R936	1-208-715-11	METAL CHIP 22K	0.5% 1/16W
R941	1-218-969-11	RES-CHIP 22K	5% 1/16W
R946	1-208-715-11	METAL CHIP 22K	0.5% 1/16W
R947	1-208-695-11	METAL CHIP 3.3K	0.5% 1/16W
R948	1-208-939-11	METAL CHIP 150K	0.5% 1/16W
< COMPOSITION CIRCUIT BLOCK >			
RB551	1-233-964-21	RES, NETWORK (CHIP TYPE) 3.3K	
RB552	1-233-967-11	RES, NETWORK (CHIP TYPE) 10K	

Ref. No.	Part No.	Description	Remark
RB801	1-233-973-11	RES, NETWORK (CHIP TYPE) 100K	
< SWITCH >			
S801	1-786-030-21	SWITCH, SLIDE (HOLD)	
S803	1-771-860-21	SWITCH, PUSH (1 KEY) (PROTECT DETECT)	
S804	1-771-806-61	SWITCH, PUSH (1 KEY) (RECHARGEABLE BATTERY IN DETECT)	
S805	1-762-947-12	SWITCH, PUSH (1 KEY) (OPEN)	
S806	1-762-805-21	SWITCH, PUSH (1 KEY) (OPEN/CLOSE DETECT)	
< FILTER >			
T601	1-416-405-21	FILTER, CHIP EMI (COMMON MODE)	
< THERMISTOR >			
TH601	1-533-817-21	THERMISTOR	
< VIBRATOR >			
X801	1-795-000-21	VIBRATOR, CRYSTAL (45.1584MHz)	

MISCELLANEOUS			

5	1-804-488-11	LCD MODULE	
△ 121	X-3379-508-1	SERVICE ASSY, OP (LCX-4R)	
M601	8-835-744-01	MOTOR, DC SSM18B (SPINDLE) (WITH TURN TABLE)	
M602	1-763-727-11	MOTOR, DC (SLED) (WITH GEAR)	
M603	1-763-400-21	MOTOR, DC (OVER WRITE HEAD UP/DOWN)	

The components identified by mark △ or dotted line with mark △ are critical for safety. Replace only with part number specified.

Ref. No.	Part No.	Description	Remark
	ACCESSORIES & PACKING MATERIALS		

△	1-569-007-11	ADAPTOR, CONVERSION 2P (JEW)	
	1-779-504-51	CONNECTOR, OPTICAL	
	1-794-451-51	CONNECTOR, LIGHT	
	3-234-030-01	MANUAL, INSTRUCTION (JAPANESE, ENGLISH) (JEW)	
	3-234-030-11	MANUAL, INSTRUCTION (ENGLISH)	
	3-234-030-21	MANUAL, INSTRUCTION (TRADITIONAL CHINESE) (HK, JEW)	
	3-234-030-31	MANUAL, INSTRUCTION (SPANISH) (E, JEW)	
	3-234-030-41	MANUAL, INSTRUCTION (PORTUGUESE) (JEW)	
	3-234-030-51	MANUAL, INSTRUCTION (KOREAN) (E, JEW)	
	3-234-030-61	MANUAL, INSTRUCTION (SIMPLIFIED CHINESE) (HK)	
	3-234-030-71	MANUAL, INSTRUCTION (RUSSIAN) (HK)	
	3-234-030-81	MANUAL, INSTRUCTION (HUNGARIAN, CZECH, POLISH, SLOVAKIAN) (HK)	
	3-234-030-91	MANUAL, INSTRUCTION (GERMAN) (HK)	
△ 501	1-476-855-11	ADAPTOR, AC (AC-ES305) (JEW)	
△ 501	1-476-858-11	ADAPTOR, AC (AC-ES305) (HK)	
502	1-476-763-12	CHARGE UNIT	
503	1-476-395-12	REMOTE CONTROL UNIT (RM-MC11EL)	
504	8-953-304-90	RECEIVER MDR-E805SP	
505	3-220-749-01	CASE, CARRYING	
506	1-756-194-11	BATTERY, NICKEL HYDROGEN (JEW)	
506	1-756-194-21	BATTERY, NICKEL HYDROGEN (E, HK)	
507	3-008-521-01	CASE, BATTERY CHARGE (E, HK)	
507	3-043-060-01	CASE, CHARGE (C/D) (JEW)	
508	1-251-895-11	BATTERY CASE	
509	X-3380-982-1	ATTACHMENT ASSY (E, JEW)	

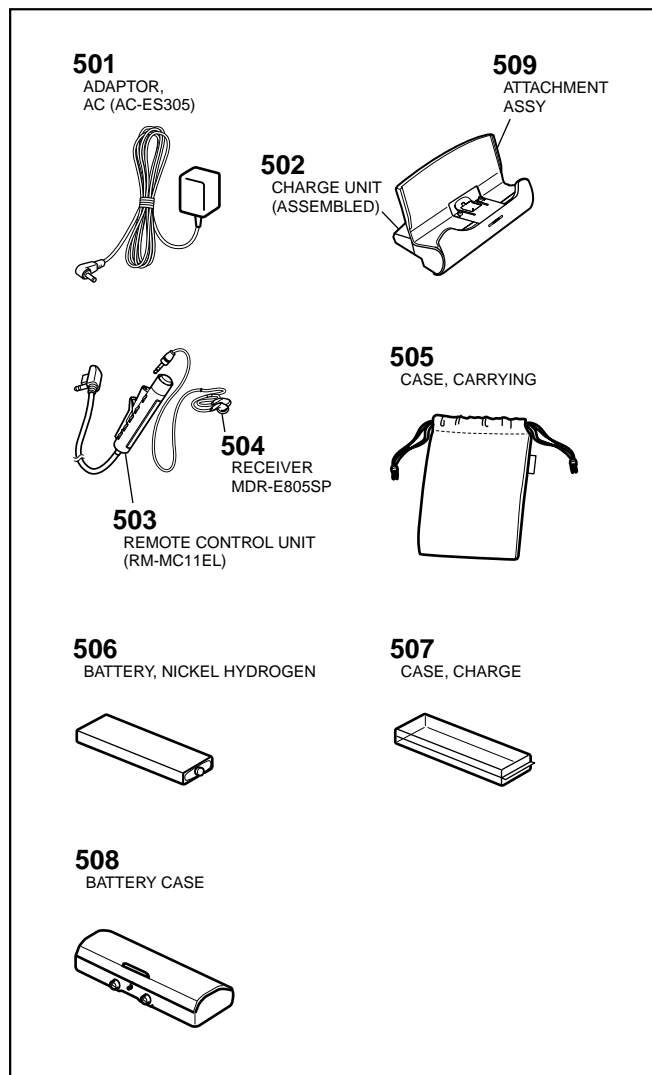

The components identified by mark △ or dotted line with mark △ are critical for safety. Replace only with part number specified.

Free Manuals Download Website

<http://myh66.com>

<http://usermanuals.us>

<http://www.somanuals.com>

<http://www.4manuals.cc>

<http://www.manual-lib.com>

<http://www.404manual.com>

<http://www.luxmanual.com>

<http://aubethermostatmanual.com>

Golf course search by state

<http://golfingnear.com>

Email search by domain

<http://emailbydomain.com>

Auto manuals search

<http://auto.somanuals.com>

TV manuals search

<http://tv.somanuals.com>