

SONY®

NTSC/PAL

Surveillance and IP Monitoring Systems



General Catalog
2005-2006

Connect Your Vision

TABLE OF CONTENTS

INTRODUCTION

Camera Technologies	2
Image Processing Technologies	4
Network Technologies	5

CAMERAS

Network Cameras	6
Analog Cameras	11
Camera Adaptors	17

SYSTEMS AND SOFTWARE

Wide View Camera	18
Intelligent Monitoring Software	19

VIDEO NETWORK STATIONS

.....	20
-------	----

DIGITAL HARD DISK RECORDER

.....	21
-------	----

MONITORS

.....	22
-------	----

SPECIFICATIONS

Network Cameras	23
Analog Cameras	28
Camera Adaptors	32
System and Software	32
Video Network Stations	33
Digital Hard Disk Recorder	34
Monitors	35

SYSTEM CONFIGURATIONS

Analog Cameras	36
Network Cameras	38
IP and Analog Cameras	39

GLOSSARY

.....	41
-------	----

INTRODUCTION

Camera Technologies

SuperExwave™ Technology (SSC-E470 Series/SSC-E450 Series)

During nighttime monitoring applications, camera sensitivity is one of the most important factors in capturing a clear image.

Sony cameras that incorporate SuperExwave technology achieve extremely high sensitivity levels especially in the near infrared wavelength region of the electromagnetic spectrum. As a result, sensitivity levels in the visible wavelength region are increased by approximately 10 %, while the sensitivity in the near infrared region is increased by approximately 50 % when compared to Exwave HAD technology. Sony SuperExwave cameras employ advanced photo-diode sensors capable of capturing a great amount of light in the near infrared region while efficiently converting this light to electric signals thus achieving high-sensitivity levels.

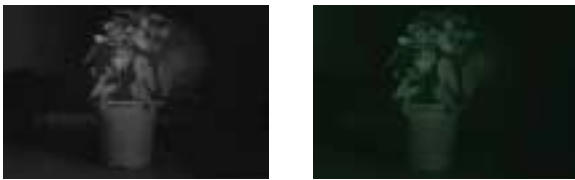

<SuperExwave> <ExwaveHAD>
Shooting environment: LED lights (wavelength 950 nm, irradiation distance 1 m), Dark room

Fig.1 SuperExwave vs Exwave HAD Image Comparison

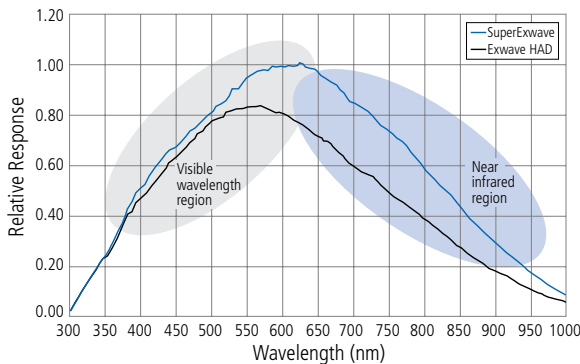

*This chart has been simplified to show the difference in sensitivity between SuperExwave and Exwave HAD. The values are for reference only.

Fig.2 SuperExwave vs Exwave HAD Spectral Sensitivity Comparison

DynaView™ Technology (SSC-DC590 series/SSC-DC570 series)

Newly developed DynaView technology achieves an incredible dynamic range that is 128 times wider than conventional cameras. Users can capture clear images even in extreme high-contrast lighting environments. By activating the DynaView mode, the camera will capture the same image twice - first with a normal shutter speed, and then with a high shutter speed. The newly developed LSI technology then combines the dark areas captured at normal shutter speed with the bright areas captured at high shutter speed to create one image.

The result is an extremely high-contrast picture that is unattainable with a conventional camera. (See Fig. 3) Additionally, DynaView technology allows the cameras to achieve more powerful Back- Light Compensation (BLC). While conventional BLC can result in over exposure when capturing background images, DynaView reduces this to a minimum by using a high shutter speed for the background, which consequently provides optimum exposure for both the subject and the background.

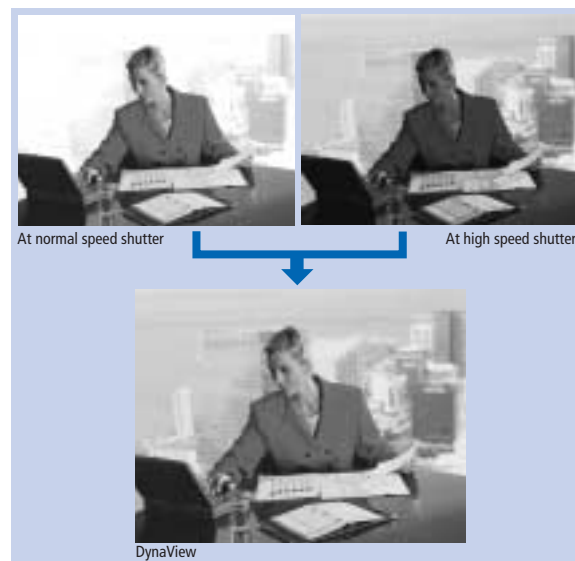

Fig.3 Dynaview Technology

Variable Gamma Curve (SSC-DC590 series/SSC-DC570 series/SSC-DC80 series)

Users can choose from four preset gamma curves, including two unique gamma curves, so that the brightness levels of captured images are controlled precisely. Images in their entirety can be displayed clearly and accurately. (i.e. not too bright and not too dark). (See Fig. 4)

One of the two unique gamma curves reduces the brightness level of the dark portions of the image, while increasing the brightness level of the bright portions of the image, which is ideal for scenes that have very little contrast (SCENE2; See Fig. 5).

The other unique gamma curve increases the brightness level of the dark portions of the image, while reducing the brightness level of the bright portions of the image (SCENE3; See Fig. 5).

By selecting a gamma curve that is appropriate for a given scene, captured images can be reproduced clearly and sharply.

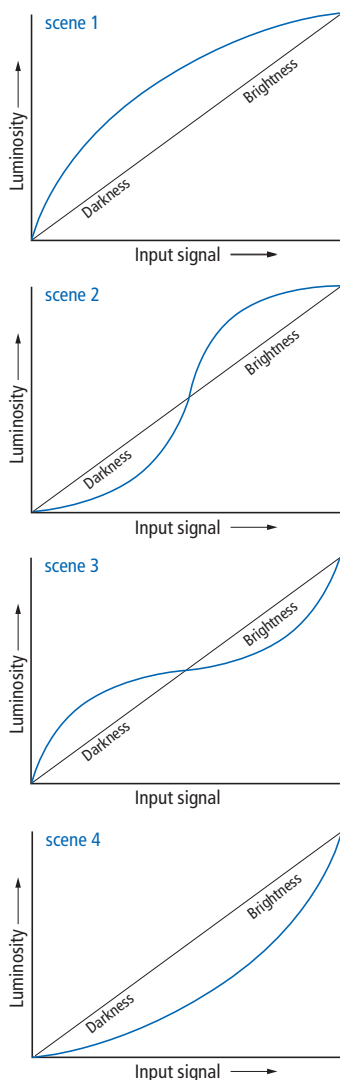

Fig.4 Four Preset Gamma Curves

SCENE 2



SCENE 3



Fig.5 Image Comparison

Image Processing Technologies

JPEG vs. MPEG-4

JPEG compression, which is conventionally used in surveillance and monitoring systems is very good for capturing high-quality still images. MPEG-4, on the other hand, is ideal for image transfer over a network while maintaining high-quality moving images. This is because MPEG-4 requires a relatively small amount of network bandwidth as a result of its structure as can be seen below.

JPEG

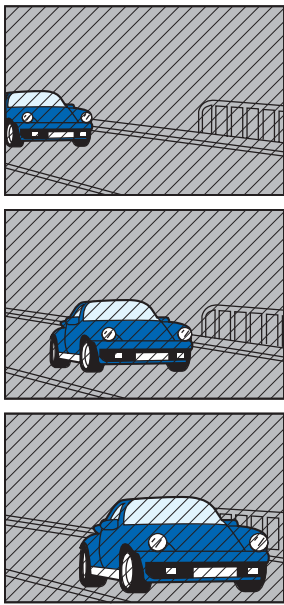

At 30 fps, 1 sec = 30 images

MPEG-4

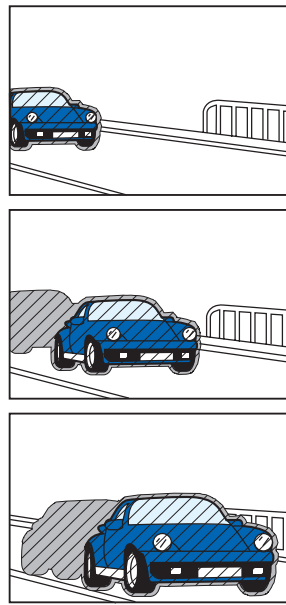

1 GOV, 1 sec. = 1 I-VOP and 29 P-VOPs

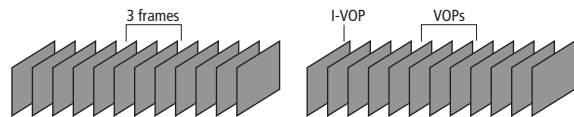

Note: Each frame in MPEG-4 is referred to as a Video Object Plane (VOP). A Group of VOPs (GOV) comprises of one second* of video. An I-VOP is the first (Initial) "frame" of a GOV and is often referred to as an "anchor." The I-VOP is similar to a JPEG image. P-VOPs are "Predictive" VOPs and only "captures" movement relative to the previous VOP.

*The default GOV setting for Sony MPEG-4 cameras is one second. The length of a GOV can be set between one and five seconds.

Rough Calculation of Data Size

JPEG

With JPEG at 30 fps, 1 sec = 30 images. Assuming each JPEG image is 30 KB in size, then one second of video is 900 KB. At 8 bits per Byte, this translates to **7.2 Mb/s**

MPEG-4

With MPEG-4, the I-VOP is approximately 30 KB in size. Assuming there is little movement in the image, each P-VOP is approximately 2 KB in size. This means that 1 second of data is approximately 88 KB. Again, using the same calculations as above, this translates to **704 Kb/s. This is approximately 1/10th the size of JPEG data.**

Activity Detection vs. Motion Detection (SNC Series Cameras)

The following is a brief explanation outlining the differences between Motion Detection and Activity Detection: The general difference in concept between the two detection methods is that Motion Detection utilizes vector information associated with movement while Activity Detection utilizes the difference in illumination between frames. Activity Detection is available with JPEG compression while Motion Detection is available with MPEG-4 compression.

Activity Detection

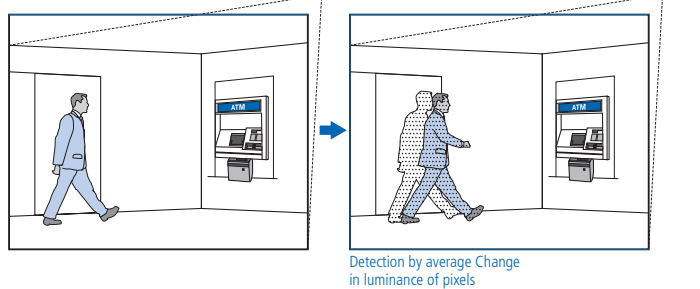

Detection by average Change in luminance of pixels

Sony Activity Detection systems utilize hardware that performs difference calculations in luminance between frames. The absolute value of the difference in luminance of each pixel is taken from one frame to the next. If the sum of the difference is greater than a preset threshold, then an alarm is triggered.

Motion Detection

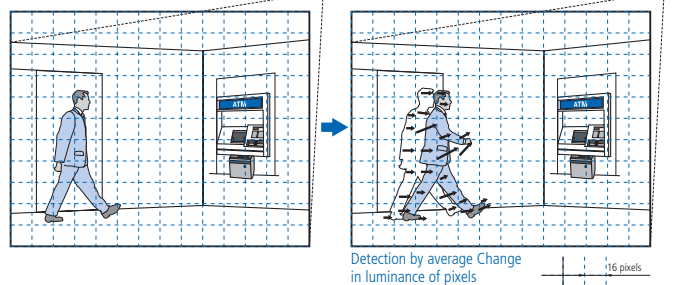

Detection by average Change in luminance of pixels

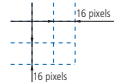

Motion Detection systems utilize a Sony advanced algorithm to determine whether or not there is actual movement in the camera viewing area. This algorithm is based on vector information available and inherent in MPEG-4 compression. The vector information is determined based on the amount of movement in 16 x 16 pixel-areas in the grid.

Motion Detection has an advantage over Activity Detection because it can reduce the number of false alarms caused by noise. Other advantages of Sony systems that use Motion Detection are that up to four distinct Motion Detection areas can be assigned, and real time indicators are available to monitor sensitivity and threshold levels.

Network Technologies

Adaptive Rate Control (ARC)

ARC is a feature that adjusts the compression bit rate and the frame rate of MPEG-4 data in order to meet changing traffic conditions over a network. Round Trip Time (RTT) and actual IP packet loss are both monitored to determine traffic conditions, and the bit rate and frame rate are adjusted automatically. "Drop Outs" (a breakup in transmitted images) can be avoided when a system is equipped with the ARC feature. The following is a graphical representation of how ARC works:

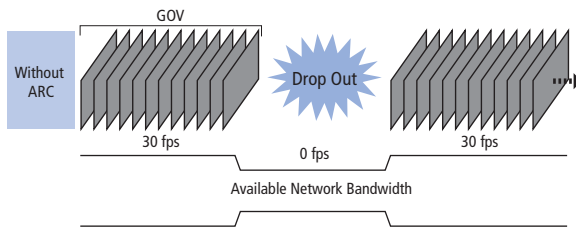

Without an ARC feature, as the available network bandwidth is reduced due to high-traffic conditions, "Drop Outs" occur.

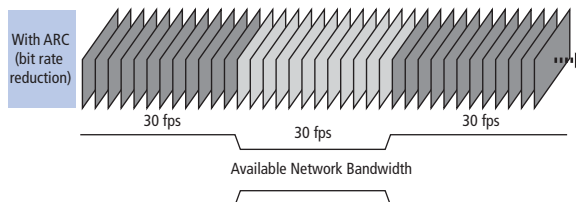

With ARC, as the available network bandwidth is reduced due to high-traffic conditions, the MPEG-4 data bit rate is reduced. This lowers image resolution slightly, but smooth moving images are still transferred.

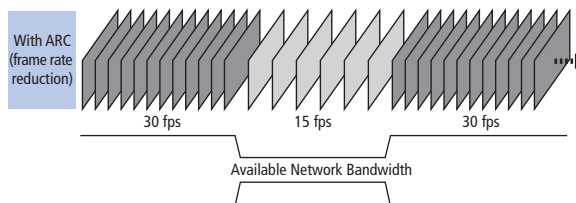

If network traffic conditions continue to increase, then the ARC feature lowers the frame rate of the data so that dropouts do not occur and a continuous image stream is transferred. This method still provides smooth moving images at a lower frame rate.

IPELA

Stunning video and audio brought to you by "IPELA" fashions the novel reality for the modern businessperson. Sharing ideas and dreams as if you are collocated when your counterpart is half-way around the world, experiencing images as if you are actually there, this is "IPELA." Real audiovisual communication over networks-this is business communication of the future, this is business communication brought to you today, this is "IPELA."

SNC-RZ30N/2, SNC-RZ30P/2 NEW



- High performance IP network color camera with integrated pan/tilt/zoom
- JPEG compression
- Remote monitoring from PCs using Microsoft Internet Explorer or Sony's IMZ-RS Series Intelligent Monitoring Software
- 100Base-TX/10Base-T Ethernet
- Integral 25x auto-focus zoom lens covers a wide range of viewing angles
- High-speed and quiet pan/tilt mechanism
- High picture quality - 1/6-type Super HAD™ CCD
- High sensitivity - 2.5 lx (F1.6, 50IRE)
- High-frame rate of up to 30 fps (SNC-RZ30N/2)/25 fps (SNC-RZ30P/2) at 640 x 480) sized image
- Four selectable image sizes
- Pan/Tilt operation - 340 degree Pan range/115 degree Tilt range
- Day/Night mode - automatically senses lighting changes and switches camera mode from color to B/W or via an external trigger
- Image stabilizer
- Simultaneous access up to 50 users
- Networking security features - IP filtering/Password protection
- Activity detection and alarm trigger functions
- Image transfer using FTP or SMTP
- RS-232C/RS-485 transparency interface for control and operation of external equipments
- Two Type II PC card*1 slots - supports Memory Stick, Flash memory card, ATA HDD card and IEEE802.11b Wireless LAN Card
- Wall-mount or ceiling-mount operation
- Analog composite video output for local analog viewing or recording

*1 Please contact your local Sony sales office for compatible PC cards and wireless card.

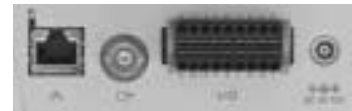

SNC-RZ30N/2, RZ30P/2 Rear

SNC-RZ25N/SNC-RZ25P NEW



IPELA

- All-in-one IP network color camera with integrated pan/tilt/zoom
- MPEG-4 and JPEG compression
- Remote monitoring from PCs using Microsoft Internet Explorer or Sony's IMZ-RS Series Intelligent Monitoring Software
- 100Base-TX/10Base-T Ethernet
- Integral 18x auto-focus zoom lens covers a wide range of viewing angles
- High picture quality - 1/4-type CCD with Exwave HAD technology
- High sensitivity - 0.7 lx (F1.4, 50IRE)
- High-frame rate of up to 30 fps (SNC-RZ25N)/25 fps (SNC-RZ25P) at 320 x 240 sized image
- Six selectable image sizes
- Pan/Tilt operation - 340 degree Pan range/120 degree Tilt range
- External microphone input and speaker output for audio monitoring
- Day/Night function - automatically senses lighting changes and switches camera mode from color to B/W or via an external trigger
- Adaptive rate control function provides smooth video over network by adjusting compression ratio and frame rate automatically
- Multicasting capability
- Simultaneous access up to 20 (JPEG mode)/10 (MPEG mode) users
- Networking security features - IP filtering/Password protection
- Motion detection*2 and alarm trigger functions
- Image transfer using FTP or SMTP
- Compact Flash™ Type card slot - support an optional SNCA-CFW1 Wireless Card or Compact Flash™ card
- Wall-mount or ceiling-mount operation
- Analog composite video output for local analog viewing or recording

*2 Motion detection function can be used when a monitoring image is set to a MPEG-4.



SNC-RZ25N/RZ25P Rear

SNC-Z20N/SNC-Z20P



- Fixed All-in-one IP network color camera with integrated zoom lens
- JPEG compression
- Remote monitoring from PCs using Microsoft Internet Explorer or Sony IMZ-RS Series Intelligent Monitoring Software
- 100Base-TX/10Base-T Ethernet
- Integral 18x auto-focus zoom lens covers a wide range of viewing angles
- High picture quality - 1/4-type CCD with Exwave HAD technology
- High sensitivity - Color: 0.7 lx, B/W: 0.01 lx (F1.4, 50IRE)
- High frame rate of up to 30 fps (SNC-Z20N)/25 fps (SNC-Z20P) at 640 x 480 image size
- Four selectable image sizes
- Day/Night function - automatically senses lighting changes and switches camera mode from color to B/W
- Simultaneous access up to 50 users
- Networking security features - IP filtering/password protection
- Activity detection and alarm trigger functions
- Image transfer using FTP or SMTP
- One PC card slot*3 - providing support for Memory Stick™, Flash ATA memory card, and ATA HDD card
- Wireless connection capability*3
- Analog composite video output for local analog viewing or recording
- RS-232C transparency interface for control and operation of external equipment
- AC 24 V or DC 12 V external power capability



SNC-Z20N/Z20P Rear

*3 Please contact a local Sony sales office or authorized dealer for compatible PC and wireless cards.

SNC-CS3N/SNC-CS3P



- Fixed All-in-one IP network color camera with CS-mount auto auto iris vari-focal lens
- JPEG compression
- Remote monitoring from a PC using Microsoft Internet Explorer or Sony IMZ-RS Series Intelligent Monitoring Software
- 100Base-TX/10Base-T Ethernet
- Auto-iris vari-focal lens (f=3.0 to 8.0 mm, F1.0)
- High picture quality - 1/3-type CCD with Exwave HAD technology
- High sensitivity - 0.5 lx at F1.0
- High frame rate of up to 25 fps at 640 x 480 image size
- Four selectable image sizes
- Simultaneous access up to 50 users
- Networking security features - IP filtering/password protection
- Activity detection and alarm trigger functions
- Image transfer using FTP or SMTP
- Analog composite video output for local analog viewing or recording
- RS-232C transparency interface for control and operation of external equipment
- Selectable power supply - automatically selects AC 24 V or DC 12 V for proper operation



SNC-CS3N/CS3P Rear

NETWORK CAMERAS

SNC-DF70N/SNC-DF70P **NEW**



IPELA

- All-in-one IP network mini dome color camera for both outdoor and indoor use
- MPEG-4 and JPEG compression
- Remote monitoring from PCs using Microsoft Internet Explorer or Sony's IMZ-RS series Intelligent Monitoring Software.
- 100Base-TX/10Base-T Ethernet
- Built-in CS-mount auto iris 2.7x vari-focal lens covers wide viewing angles
- Rugged design - IP66^{*4} rated
- High-picture quality - 1/4-type Super HAD CCD
- Horizontal resolution - 480 TV lines
- High sensitivity 0.9 lx (F1.0, 50IRE)
- High-frame rate of up to 30 fps (SNC-DF70N)/25 fps (SNC-DF70P) at 320 x 240 sized image
- Six selectable image sizes
- External microphone input and speaker output for bidirectional audio capability
- Day/Night function - automatically senses lighting changes and switches camera mode from color to B/W or via an external trigger
- Wall-mounted or ceiling-mounted installation
- Adaptive rate control function provides smooth video over network by adjusting compression ratio and frame rate automatically
- Multicasting capability
- Simultaneous access up to 20(JPEG mode)/10 (MPEG-4 mode) users
- Networking security features - IP filtering/Password protection
- Motion detection^{*5} and alarm trigger function
- Pre-/Post-Alarm image storage
- Image transfer using FTP or SMTP
- Analog composite video output for local analog viewing or recording

^{*4} Ingress Protection(IP) standard is a system for numerically classifying the degree of protection provided by enclosures of electrical equipment against solid objects and liquids. IP66 means there is no ingress of dust and the equipment is protected against powerful water jets.

^{*5} Motion detection function can be used when a monitoring image is set to a MPEG-4.

SNC-DF40N/SNC-DF40P **NEW**



IPELA

- All-in-one IP network mini dome color camera
- MPEG-4 and JPEG compression
- Remote monitoring from PCs using Microsoft Internet Explorer or Sony's IMZ-RS series Intelligent Monitoring Software.
- 100Base-TX/10Base-T Ethernet
- Easy GUI based operations
- Built-in CS-mount auto auto iris 2.7x vari-focal lens covers wide viewing angles
- High-picture quality - 1/4-type Super HAD CCD
- Horizontal resolution - 480 TV lines
- High sensitivity - 0.8 lx (F1.0, 50IRE)
- High-frame rate of up to 30 fps (SNC-DF40N)/25 fps (SNC-DF40P) at 320 x 240 sized image
- Six selectable image sizes
- External microphone input and speaker output for bidirectional audio capability
- Wall-mounted or ceiling-mounted installation
- Adaptive rate control function provides smooth video over network by adjusting compression ratio and frame rate automatically
- Multicasting capability
- Simultaneous access up to 20(JPEG mode)/10 (MPEG-4 mode) users
- Networking security features - IP filtering/Password protection
- Motion detection^{*6} and alarm trigger function
- Pre-/Post-Alarm image storage
- Image transfer using FTP or SMTP
- Analog composite video output for local analog viewing or recording



SNC-DF40N/DF40P Rear

^{*6} Motion detection function can be used when a monitoring image is set to a MPEG-4.

SNC-P5 NEW



IPELA

- All-in-one IP network color camera with integrated pan/tilt/zoom
- MPEG-4 and JPEG compression
- Remote monitoring from PCs using Microsoft Internet Explorer or Sony's IMZ-RS series Intelligent Monitoring Software.
- 100Base-TX/10Base-T Ethernet
- Easy GUI based operations
- High-frame rate of up to 30 fps at 320 x 240 sized image
- Six selectable image sizes
- External microphone input and speaker output for bidirectional audio capability
- Pan/Tilt operation- 120 degree Pan range/ 75 degree Tilt range
- Optical 3x zoom capability
- Adaptive rate control function provides smooth video over network by adjusting compression ratio and frame rate automatically
- Multicasting capability
- Simultaneous access up to 20(JPEG mode)/10(MPEG-4 mode) users
- Networking security features - IP filtering/Password protection
- Motion detection*7 and alarm trigger function
- Pre-/Post-Alarm image storage
- Image transfer using FTP or SMTP
- Compact Flash™ type card slot- support for optional SNCA-CFW1 Wireless Card or Compact Flash card
- Wall-mounted or ceiling-mounted installation
- Analog composite video output for local analog viewing or recording
- Can be used in outdoor environment with the optional SNCA-HP5 Housing Kit



SNC-P5 Rear

*7 Motion detection function can be used when a monitoring image is set to a MPEG-4.

SNC-P1 NEW



IPELA

- Fixed All-in-one IP network color camera
- MPEG-4 and JPEG compression
- Compact and slim design
- Remote monitoring from PCs using Microsoft Internet Explorer or Sony's IMZ-RS series Intelligent Monitoring Software.
- 100Base-TX/10Base-T Ethernet
- Easy GUI based operations
- High-frame rate of up to 30 fps at 320 x 240 sized image
- Six selectable image sizes
- External microphone input and speaker output for bidirectional audio capability
- Adaptive rate control function provides smooth video over network by adjusting compression ratio and frame rate automatically
- Multicasting capability
- Simultaneous access up to 20(JPEG mode)/10(MPEG-4 mode) users
- Networking security features - IP filtering/Password protection
- Motion detection*8 and alarm trigger function
- Pre-/Post-Alarm image storage
- Image transfer using FTP or SMTP
- Desk-top, wall-mounted, or ceiling-mounted installation
- Analog composite video output for local analog viewing or recording

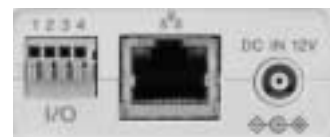

SNC-P1 Rear

*8 Motion detection function can be used when a monitoring image is set to a MPEG-4.

NETWORK CAMERAS

SNC-M3/SNC-M3W NEW



- All-in-one IP network color camera with integrated pan/tilt
- MPEG-4 and JPEG compression
- Compact and lightweight design
- Remote monitoring from PCs using Microsoft Internet Explorer
- 100Base-TX/10Base-T Ethernet
- Easy GUI based operations
- High-frame rate of up to 30 fps at 320 x 240 sized image
- Three selectable image sizes
- Built-in microphone, external microphone input and speaker output for bidirectional audio capability
- Pan/Tilt operation - 120 degree Pan range/70 degree Tilt range
- Wireless operation capability (SNC-M3W)
- Simultaneous access up to 10 users (both JPEG/MPEG-4 mode)
- Networking security features - IP filtering/Password protection
- E-mail notification function with motion detection^{*9}
- Desk-top, wall-mounted, or ceiling-mounted installation

^{*9} Motion detection function can be used when a monitoring image is set to a MPEG-4.



SNC-M3/M3W Rear

SNC-M1/SNC-M1W NEW



- Fixed all-in-one IP network color camera
- MPEG-4 and JPEG compression formats
- Compact and lightweight design
- Remote monitoring from PCs using Microsoft Internet Explorer
- 100Base-TX/10Base-T Ethernet
- Easy GUI based operations
- High-frame rate of up to 30 fps at 320 x 240 sized image
- Three selectable image sizes
- Built-in microphone, external microphone input and speaker output for bidirectional audio capability
- Wireless operation capability (SNC-M1W)
- Simultaneous access up to 10 users (both JPEG/MPEG-4 mode)
- Networking security features - IP filtering/Password protection
- E-mail notification function with motion detection^{*10}
- Desk-top, wall-mounted, or ceiling-mounted installation

^{*10} Motion detection function can be used when a monitoring image is set to a MPEG-4.



SNC-M1/M1W Rear

ANALOG CAMERAS

SSC-E473/SSC-E473P/SSC-E478P **NEW**



- 1/3-type CCD with SuperExwave technology
- Advanced Digital Signal Processing (DSP) technology - provides high-horizontal resolution of 540 TV lines
- Day/Night function - automatically senses lighting changes and switches camera mode from color to B/W or via an external trigger
- High sensitivity - Color: 0.55 lx, B/W: 0.05 lx (F1.2, 50IRE)
- Slim and stylish design equipped with front and rear covers
- CCD IRIS function allows for the use of low cost manual iris lenses
- Backlight compensation: ON/OFF switchable
- AGC: TURBO/OFF switchable
- Wide range CCD IRIS (ON/OFF switchable, 1/60 to 1/100,000 s (SSC-E473), 1/50 to 1/100,000 s (SSC-E473P, SSC-E478P))
- Selectable Auto White balance mode: ATW/ATW pro
- DC-Servo lens connection capability
- CS-mount
- Variety of power requirements
SSC-E473/473P: automatically selects AC 24 V or DC 12 V for proper operation
SSC-E478P: AC 220 to 240 V operation



SSC-E473/E473P Rear



SSC-E478P Rear

SSC-E453/SSC-E453P/SSC-E458P **NEW**



- 1/3-type CCD with SuperExwave technology
- Advanced Digital Signal Processing (DSP) technology - provides high-horizontal resolution of 540 TV lines
- High sensitivity - 0.55 lx (F1.2, 50IRE)
- Slim and stylish design equipped with front and rear covers
- CCD IRIS function allows for the use of low cost manual iris lenses
- Backlight compensation: ON/OFF switchable
- AGC: TURBO/OFF switchable
- Wide range CCD IRIS (ON/OFF switchable, 1/60 to 1/100,000 s (SSC-E453), 1/50 to 1/100,000 s (SSC-E453P, SSC-E458P))
- Selectable Auto White balance mode: ATW/ATW pro
- DC-Servo lens connection capability
- CS-mount
- Variety of power requirements
SSC-E453/453P: automatically selects AC 24 V or DC 12 V for proper operation
SSC-E458P: AC 220 to 240 V operation



SSC-E453/E453P Rear



SSC-E458P Rear

ANALOG CAMERAS

SSC-DC80/SSC-DC80P/SSC-DC83/SSC-DC83P/SSC-DC88P **NEW**



- 1/2-type CCD with Exwave HAD technology
- Horizontal resolution - 480TV lines
- High sensitivity - 0.4 lx (F1.2, 50IRE)
- AGC: TURBO/NORMAL/MANUAL/OFF switchable
- Aperture: SHARP/SOFT/NORMAL switchable
- White balance: ATW PRO/ATW/3200K/5600K/MANUAL switchable
- Backlight compensation: SPOT/WEIGHT/OFF switchable
- Four selectable gamma curves
- Accepts video or DC auto iris lenses
- Camera title indication
- CS/C^{*11}-mount
- SSC-DC80/DC80P provides single cable operation (video/sync/power triple multiplex transmission) for easy installation with the optional YS-W170A/W270A (for SSC-DC80) and YS-W170PW/270P (for SSC-DC80P) camera adaptor
- Variety of power requirements
SSC-DC80/DC80P: DC 12 V operation
SSC-DC83/DC83P: automatically selects AC 24 V or DC 12 V for proper operation
SSC-DC88P: AC 220 to 240 V operation

*11 C-mount adaptor is supplied



SSC-DC80/DC80P Rear



SSC-DC83/DC83P Rear



SSC-DC88P Rear

SSC-DC573/SSC-DC573P/SSC-DC578P **NEW**

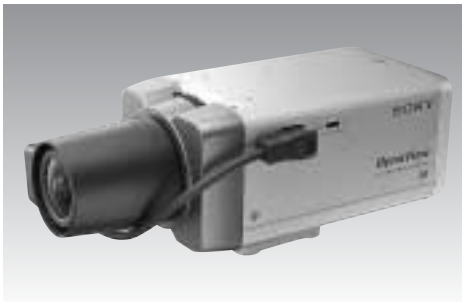

- 1/3-type CCD with DynaView technology
- Wide dynamic range with DynaView technology - ideal for obtaining clear color images under severe highlight or backlight conditions
- Horizontal resolution - 480 TV lines
- High sensitivity - 0.8 lx (F1.4, 50 IRE)
- AGC: TURBO/NORMAL/MANUAL/OFF switchable
- Aperture: SHARP/SOFT/NORMAL switchable
- White balance: ATW PRO/ATW/3200K/5600K/MANUAL switchable
- Backlight compensation: DYNVIEW/SPOT/WEIGHT/OFF switchable
- Four selectable gamma curves
- Accepts video or DC auto iris lenses
- Camera title indication
- Wide range CCD IRIS (1/60 to 1/100,000 s, (SSC-DC573), 1/50 to 1/100,000 s (SSC-DC573P, SSC-DC578P))
- Activity detection
- Privacy Zone Masking function
- Two preset memories for camera setting
- CS-mount
- Variety of power requirements
SSC-DC573/DC573P: automatically selects AC 24 V or DC 12 V for proper operation
SSC-DC578P: AC 220 to 240 V operation



SSC-DC573/DC573P Rear



SSC-DC578P Rear

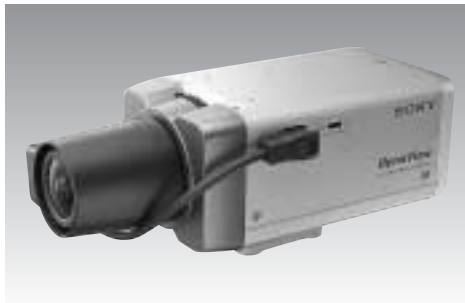

- 1/3-type CCD with DynaView technology
- Wide dynamic range with DynaView technology - ideal for obtaining clear color images under severe highlight or backlight conditions
- Day/Night function - automatically senses lighting changes and switches camera mode from color to B/W or via an external trigger
- Horizontal resolution - 480 TV lines
- High sensitivity - Color: 0.8 lx, B/W: 0.07 lx (F1.4, 50 IRE)
- AGC: TURBO/NORMAL/MANUAL/OFF switchable
- Aperture: SHARP/SOFT/NORMAL switchable
- White balance: ATW PRO/ATW/3200K/5600K/MANUAL/DUAL switchable
- Backlight compensation: DYNAVIEW/SPOT/WEIGHT/OFF switchable
- Four selectable gamma curves
- Accepts video or DC auto iris lenses
- Camera title indication
- Wide range CCD IRIS (1/60 to 1/100,000 s, (SSC-DC590, SSC-DC593), 1/50 to 1/100,000 s (SSC-DC593P, SSC-DC598P))
- Activity detection and alarm trigger functions
- Privacy Zone Masking function
- Two preset memories for camera setting
- RS-485 interface for remote control
- CS-mount
- SSC-DC590 provides single cable operation (video/sync/power triple multiplex transmission) for easy installation with the optional YS- W170A/W270A camera adaptor.
- Variety of power requirements
 SSC-DC590: DC 12 V operation
 SSC-DC593/DC593P: automatically selects AC 24 V or DC 12 V for proper operation
 SSC-DC598P: AC 220 to 240 V operation



SSC-DC590 Rear



SSC-DC593/DC593P Rear



SSC-DC598P Rear

ANALOG CAMERAS

SSC-DC374/SSC-DC372P/SSC-DC378P **NEW**



- 1/3-type Super HAD CCD
- Horizontal resolution - 480 TV lines
- High sensitivity - 0.8 lx (F1.2, 50IRE)
- Compact and lightweight design
- CCD IRIS function allows for the use of low cost manual iris lenses
- Backlight compensation: ON/OFF switchable
- AGC: TURBO/OFF switchable
- Wide range CCD IRIS (ON/OFF switchable, 1/60 to 1/100,000 s (SSC-DC374), 1/50 to 1/100,000 s (SSC-DC372P, SSC-DC378P))
- Wide range Auto Tracing White balance (ATW)
- Accepts DC auto iris lenses
- CS-mount
- Variety of power requirements
SSC-DC374: AC 24 V operation
SSC-DC372P: DC 12 V operation
SSC-DC378P: AC 220 to 240 V operation



SSC-DC374 Rear



SSC-DC372P Rear



SSC-DC378P Rear

SSC-DC193/SSC-DC193P/SSC-DC198P



- Ideal for low light applications
- 1/3-type Super HAD CCD
- Horizontal resolution - 330 TV lines
- High sensitivity - 0.6 lx (F1.2, 50IRE)
- Compact and lightweight design
- Built-in tripod screw holes for easy installation
- Digital Signal Processing (DSP)
- Sync system
SSC-DC193/DC193P: Internal/AC line lock
SSC-DC198P: AC line lock
- Backlight Compensation: ON/OFF switchable
- AGC: TURBO/OFF switchable
- Wide range CCD IRIS (ON/OFF switchable, 1/60 to 1/100,000 s (SSC-DC193), 1/50 to 1/100,000 s (SSC-DC193P, SSC-DC198P))
- CCD IRIS function allows for the use of low cost manual iris lenses
- Wide range Auto Tracing White balance (ATW)
- Accepts video or DC auto iris lenses
- CS-mount
- Variety of power requirements
SSC-DC193/DC193P: automatically selects AC 24 V or DC 12 V for proper operation
SSC-DC198P: AC 220 to 240 V operation



SSC-DC193/DC193P Rear



SSC-DC198P Rear

SSC-DC174/SSC-DC172P **NEW**



- 1/3-type CCD with Super HAD technology
- Horizontal resolution - 330 TV lines
- High sensitivity - 0.6 lx (F1.2, 50IRE)
- Digital Signal Processing (DSP) technology provides powerful picture-contrast control
- Compact and lightweight design
- CCD IRIS function allows for the use of low cost manual iris lenses
- Built-in tripod screw holes for easy installation
- Backlight compensation: ON/OFF switchable
- AGC: TURBO/OFF switchable
- Wide range CCD IRIS (ON/OFF switchable, 1/60 to 1/100,000 s (SSC-DC174), 1/50 to 1/100,000 s (SSC-DC172P))
- Wide range Auto Tracing White balance (ATW)
- Accepts DC auto iris lenses
- CS-mount
- Variety of power requirements
 SSC-DC174: AC 24 V operation
 SSC-DC172P: DC 12 V operation



SSC-DC174 Rear



SSC-DC172P Rear

SSC-M383/SSC-M383CE/SSC-M388CE (B/W)



- Ideal for low light applications
- 1/3-type CCD with Exwave HAD technology
- Horizontal resolution - 570 TV lines
- High sensitivity - 0.07 lx (F1.2, 50IRE)
- Compact and lightweight design
- Built-in tripod screw holes for easy installation
- Sync system
 SSC-M383/M383CE: Internal/AC line lock
 SSC-M388CE: AC line lock
- Backlight Compensation: ON/OFF switchable (when CCD IRIS is ON)
- AGC: TURBO (up to 24 dB)/OFF switchable
- Wide range CCD IRIS (ON/OFF switchable, 1/60 to 1/100,000 s (SSC-M383), 1/50 to 1/100,000 (SSC-M383CE, SSC-M388CE))
- CCD IRIS function allows for the use of low cost manual iris lenses
- Accepts video or DC auto iris lenses
- CS-mount
- Variety of power requirements
 SSC-M383/383CE: automatically selects AC 24 V or DC 12 V for proper operation
 SSC-M388CE: AC 220 to 240 V operation



SSC-M383/383CE Rear



SSC-M388CE Rear

ANALOG CAMERAS

SSC-M183/SSC-M183CE/SSC-M188CE (B/W)



- Ideal for low light applications
- 1/3-type Super HAD CCD
- Horizontal resolution - 380 TV lines
- High sensitivity - 0.06 lx (F1.2, 50IRE)
- Compact and lightweight design
- Built-in tripod screw holes for easy installation
- Sync system
 - SSC-M183/M183CE: Internal/AC line lock
 - SSC-M188CE: AC line lock
- Backlight Compensation: ON/OFF switchable (when CCD IRIS is ON)
- AGC: TURBO (up to 24 dB)/OFF switchable
- Wide range CCD IRIS (ON/OFF switchable, 1/60 to 1/100,000 s (SSC-M183), 1/50 to 1/100,000(SSC-M183CE, SSC-M188CE))
- CCD IRIS function allows for the use of low cost iris lenses
- Accepts video or DC auto iris lenses
- CS-mount
- Variety of power requirements
 - SSC-M183/183CE: automatically selects AC 24 V or DC 12 V for proper operation
 - SSC-M188CE: AC 220 to 240 V operation



SSC-M183/M183CE Rear



SSC-M188CE Rear

SSC-CD73V/SSC-CD73VT/SSC-CD73VP



- Built-in CS-mount auto iris vari-focal lens covers a wide range of viewing angles (f=3.0 to 8.0 mm)
- 1/4-type Super HAD CCD
- High sensitivity - Color: 0.9 lx, B/W: 0.2 lx (F1.0, 50IRE, AGC ON)
- Rugged design - IP66 rated
- Day/Night mode - automatically senses lighting changes and switches camera mode from color to B/W or via an external trigger
- BNC type analog composite video output (SSC-CD73V, SSC-CD73VP)
- Network Video Technologies (NVT) twisted pair interface for easy installation (SSC-CD73VT)
- Designed for easy mounting and installation
- AC Line Lock capability for AC operation
- Backlight Compensation: ON/OFF switchable
- AGC: TURBO (up to 24 dB)/OFF switchable
- Wide range Auto Tracing White balance (ATW)
- CS-mount
- Dual power capability - automatically selects AC 24 V or DC 12 V for proper operation

SSC-CD43V/SSC-CD43VT/SSC-CD43VP



- Built-in CS-mount auto iris vari-focal lens covers a wide range of viewing angles (f=3.0 to 8.0 mm)
- 1/4-type Super HAD CCD
- High sensitivity - 0.8 lx (F1.0, 50IRE, AGC ON)
- BNC type analog composite video output (SSC-CD43V, SSC-CD43VP)
- Network Video Technologies (NVT) twisted pair interface for easy installation (SSC-CD43VT)
- Designed for easy mounting and installation
- AC Line Lock capability for AC operation
- Backlight Compensation: ON/OFF switchable
- AGC: TURBO (up to 24 dB)/OFF switchable
- Wide range Auto Tracing White balance (ATW)
- CS-mount
- Dual power capability - automatically selects AC 24 V or DC 12 V for proper Operation

CAMERA ADAPTORS

YS-W270A/YS-W270P NEW



- Camera adaptor for Color video camera. (YS-W270A is for the SSC-DC590/DC80 and YS-W270P is for the SSC-DC80P)
- Provides DC power and video/sync signal between the adaptor and multiple cameras over a single coaxial cable
- Up to four cameras can be connected
- Internal or external synchronization with MPX-VS or MPX-VD
- Maximum cable length: 600 m with RG-11A/U (7C-2V) coaxial cable



YS-W270A/W270P Rear

YS-W170A/YS-W170P NEW



- Camera adaptor for Color video camera. (YS-W170A is for the SSC-DC590/DC80 and YS-W170P is for the SSC-DC80P)
- Provides DC power and video/sync signal between a single adaptor and the camera over a coaxial cable
- Internal or external synchronization with MPX-VS or MPX-VD
- Maximum cable length: 600 m with RG-11A/U (7C-2V) coaxial cable



YS-W170A/W170P Rear

SYSTEMS AND SOFTWARE

Wide View Camera

XIS-10DC **NEW**



IPELA



- Sensor camera capable of 360 degree coverage coupled with a Pan/Tilt/Zoom (PTZ) network camera in a unique IP66-compliant housing for outdoor use
- Easy-to-use software with an intuitive and user-friendly GUI
- Supplied extension arm for wall mounting, attachment to pole, or attachment to telephone pole^{*12}
- Separate viewer windows on a single screen (panorama view, PTZ camera view, tracking history thumbnail images, and views from two optional fixed cameras)
- Records images from both the sensor camera and PTZ camera
- High-quality JPEG compressed images
- High-resolution images 640 x 480, sensor camera: 7.5 fps, PTZ camera 10 fps
- "Auto cleanup" function to either overwrite data or stop recording when the disk is full
- Supports optional SSC Series analog cameras^{*13} or SNC-Z20 network camera (monitoring)
- Recording of images from optional cameras when an e-mail is received from either the SNC-Z20 or SNT-V504/V501. E-mails can be sent when an alarm is triggered by either the sensor-in or the activity detection system^{*14}
- Wide area coverage of approximately 40 meters
- Automatic tracking and zooming in on moving objects using sophisticated tracking algorithm
- Search and playback of recorded images
- Optional wireless network configuration available
- Easy setup in LAN environment with automatic assignment of camera IP addresses

^{*12} When attaching to telephone pole, steel bands are required.

^{*13} Requires optional SNT-V504 or SNT-V501.

^{*14} Recording time is variable and can be set in increments of seconds.

Intelligent Monitoring Software

IMZ-RS300 Series (IMZ-RS301/RS304/RS309/RS316/RS332/RS300C) NEW



- Remote control, monitoring, and recording of up to 32 video cameras
 - IMZ-RS301: Control PC software/license for 1 network video source
 - IMZ-RS304: Control PC software/license for 4 network video sources
 - IMZ-RS309: Control PC software/license for 9 network video sources
 - IMZ-RS316: Control PC software/license for 16 network video sources
 - IMZ-RS332: Control PC software/license for 32 network video sources
 - IMZ-RS300C: Software/license for client PC when in client/server configuration
- Intelligent Motion Detection function
- Supports MPEG-4 network cameras
- Capable of recording, monitoring, and playing back G.711/G.726 audio
- "Layout Editor" for creating customized site layouts
- Monitoring from a Web browser^{*15}
- Definable "Action Areas" allows monitoring of specific cameras or areas
- Automatic layout "Tour" function
- "Hot Spot" monitoring and dual monitor support
- Supports a high frame rate of 30 fps at 640 x 480 pixels from network cameras such as the SNC-RZ30N^{*16}
- Manual/Scheduled/Alarm/Pre-alarm recording capabilities
- Supports playback during recording
- Quick and easy search of recorded images by thumbnail using time codes, alarm events, and/or comments as the search key
- Activity and/or motion detection to trigger an alarm
- E-mail notification when an alarm is triggered
- Dynamic Masking function to mask unwanted or prohibited areas of an image
- Camera Pan/Tilt/Zoom control capability
- Camera preset positions can be assigned and these positions can be "toured"
- API (Application Programming Interface) for developers and integrators to customize systems
- AVI file export
- Compatible with disk and/or tape archive systems
- Time stamped comments for easy search of material
- User/Group privileges to limit access to specific functions
- Customized logging reports for troubleshooting

^{*15} Requires Web gateway software

^{*16} Supports a maximum of 25 fps when connected to PAL cameras such as the SNC-RZ30P. In order to achieve the maximum frame rate, a client PC with adequate processing power and an adequate network environment are required.

VIDEO NETWORK STATION

SNT-V504/V501 **NEW**



SNT-V504



SNT-V501

- Ideal for video monitoring over networks (converts analog camera signals to TCP/IP)
- Camera images can be remotely monitored and controlled over existing networks (LAN/WAN)
- Built-in web server provides user-friendly interface for easy monitoring and control from networked PCs running a Web browser
- The SNT-V504 supports up to four video surveillance cameras and the SNT-V501 supports one camera
- Supports a high frame rate of up to 30 fps^{*17} at a high-resolution of 704 x 480 (NTSC)/704 x 576 (PAL) to provide clear and smooth moving images
- Easy to install, expand, and maintain
- Multi-user access and password protection
- Video Out for local monitoring
- PC Card Slot^{*18} to increase storage capacity with flash memory or to configure in a wireless network with an IEEE 802.11b-compliant wireless PC card
- RS-232C/485 Interface for camera control including Pan/Tilt/Zoom control
- Transparency function allows control of external equipment from a PC on the network
- Built-in activity detection function to trigger an alarm
- Alarm image buffering allows for storage of pre-alarm and post-alarm images
- When an alarm occurs, a JPEG file showing the alarm event can be sent to pre-determined e-mail addresses or to a server
- Alternate viewing modes with the SNT-V504, including single screen and two types of four-division split screens
- "Tour" feature for scanning pre-assigned patterns
- Viewing from a PDA^{*19}

^{*17} Supports a maximum of 25 fps with PAL camera systems. In order to achieve the maximum frame rate, a client PC with adequate processing power and an adequate network environment are required.

^{*18} Please contact your local Sony office or authorized dealer for information on memory and wireless cards compatible with the SNT-V501/V504.

^{*19} Compatible with PDAs running Microsoft® Pocket PC®. Requires the Jeode plug-in Ver. 1.9.1.



SNT-V504 Rear Panel



SNT-V501 Rear Panel

DIGITAL HARD DISK RECORDER

HSR-X206/HSR-206P

NEW



- 6-channel digital hard disk recorder with built-in multiplexer
- Large capacity 320 GB HDD (160 GB x 2, ATA/ATAPI-5 standard)
- Long recording time of 2686 hours (112 days) when in high mode (1-channel input, 1 picture/s)
- High-resolution (720 x 240) NTSC/(720 x 288) PAL in field recording mode and high picture quality recording and playback
- Motion-JPEG compression
- Network capability (built-in 100Base-TX Ethernet interface)
- Real-time live video monitoring from all six cameras, each at a frame rate of 30 fps^{*20}
- Easy settings from the single-page setup menu
- Playback during recording
- Alarm recording, timer recording, programmed recording, and activity detection function
- Audio single-channel recording and playback
- Intelligent search function allows five types of searches
- Three data storage areas on HDD (normal recording, alarm recording, and archive area)
- Built-in Compact Flash™ (CF) card slot to copy images on removable media, such as a CF card or Memory Stick Duo™ using a CF card adapter
- Variable-speed picture search
- Auto delete function
- 2x digital zoom
- Video loss alarm
- Two security lock levels (User/Administer levels)
- HDD mirroring function
- 30-day backup on settings if power fails

^{*20} The HSR-X206P displays these images at 25 fps



HSR-X206 Rear Panel

MONITORS

LMD-1410 NEW



- 14-inch*²¹ LCD monitor
- Panel Resolution: 640 x 480 (VGA)
- Accepts NTSC and PAL
- Accepts Composite, Y/C, Component, and RGB signals
- -3% underscan and +5% overscan
- Switchable aspect ratio (4:3 and 16:9)
- On-Screen menu for adjustment/operation
- Parallel Remote Control
- Color Temperature Adjustment
- VESA mounting with 100 mm spacings
- 19-inch EIA standard rack mountable
- Monitor stand supplied
- Built-in speaker for audio monitoring
- AC 100 to 240 V, 50/60Hz

*²¹ 13.94-inch viewable area measured diagonally



LMD-1410 Rear

LMD-2010 NEW



- 20-inch*²² LCD monitor
- Panel Resolution: 640 x 480 (VGA)
- Accepts NTSC and PAL
- Accepts Composite, Y/C, Component, and RGB signals
- -3% underscan and +5% overscan
- Switchable aspect ratio (4:3 and 16:9)
- On-Screen menu for adjustment/operation
- Parallel Remote Control
- Color Temperature Adjustment
- VESA mounting with 100 mm spacings
- 19-inch EIA standard rack mountable
- Monitor stand supplied
- Built-in speaker for audio monitoring
- AC 100 to 240 V, 50/60Hz

*²² 20.1-inch viewable area measured diagonally



LMD-2010 Rear

SPECIFICATIONS

Network Cameras

	SNC-RZ30N/2	SNC-RZ30P/2	SNC-RZ25N	SNC-RZ25P
Camera				
Image device	1/6-type Super HAD CCD		1/4-type CCD with EXwave HAD Technology	
Number of effective pixels (H x V)	630,000 (962 x 654)	740,000 (962 x 774)	380,000 (768 x 494)	440,000 (752 x 582)
Electronic shutter	Auto/Manual			
Gain control	Auto/Manual			
Exposure control	Auto/Shutter-priority/Iris-priority/Manual/Backlight compensation			
White balance mode	Auto/Indoor/Outdoor/One push auto/ATW/Manual			
Lens type	Auto-focus zoom lens			
Zoom ratio	25x Optical (12x Digital)		18x Optical (12x Digital)	
Horizontal viewing angle	45 to 2.0 degrees		48 to 2.7 degrees	
Focal length	f=2.4 to 60 mm		f=4.1 to 73.8 mm	
F number	F1.6 (Wide), F2.7 (Tele)		F1.4 (Wide), F3.0 (Tele)	
Pan angle	-170 to +170 degrees			
Tilt angle	-90 to +25 degrees		-90 to +30 degrees	
Other functions	Day/Night, Image Flip, Activity Detection, Image stabilizer		Day/Night, Image Flip, Motion Detection	
Image				
Image size				
JPEG	736 x 480, 640 x 480, 320 x 240, 160 x 120	736 x 544, 640 x 480, 320 x 240, 160 x 120	640 x 480, 480 x 360, 384 x 288, 320 x 240, 256 x 192, 160 x 120	
MPEG-4	-		640 x 480, 480 x 360, 384 x 288, 320 x 240, 256 x 192, 160 x 120	
Compression format	JPEG		JPEG/MPEG-4 (Selectable)	
Maximum frame rate				
JPEG	30 fps (640 x 480)	25 fps (640 x 480)	30 fps (320 x 240)	25 fps (320 x 240)
MPEG-4	-		30 fps (320 x 240)	25 fps (320 x 240)
Audio				
Compression format	-		G.726 (40, 32, 24, 16 kbps), G.711 (64 kbps)	
Network				
Protocols	TCP/IP, ARP, ICMP, DHCP, DNS, HTTP, FTP, SMTP, NTP, SNMP(MIB2)		TCP/IP, UDP, ARP, ICMP, DHCP, DNS, HTTP, FTP, SMTP, NTP, SNMP(MIB2), RTP/RTCP, PPPoE	
Number of clients	50		JPEG: 20, MPEG-4: 10	
Interface				
Ethernet	100Base-TX/10Base-T (RJ-45)			
Serial interface	RS-485/RS-232C		RS-232C	
Card slot	PC card Type II x 2			
Analog video output	BNC x 1, 1.0 Vp-p, 75 Ω unbalanced, sync negative			
I/O port	Sensor in x 3, Alarm out x 2		Sensor input x 2, Alarm output x 2	
External microphone input	-			
Audio line output	-			
Analog video output				
Signal system	NTSC	PAL	NTSC	PAL
Horizontal resolution	480 TV lines		More than 50 dB	
S/N ratio	more than 48 dB		More than 50 dB	
Minimum illumination	Color: 2.5 lx (AGC ON, F1.6, 50IRE) B/W: 0.1 lx (AGC ON, F1.6, 50IRE)		Color: 0.7 lx (AGC ON, F1.4, 50IRE) B/W: 0.06 lx (AGC ON, F1.4, 50IRE)	
General				
Mass	approx. 1,200 g (2 lb 10 oz)		approx. 1,300 g (2 lb 14 oz)	
Dimensions (W x H x D)	140 x 175 x 144 mm (5 5/8 x 7 x 5 3/4 inches) without projection		140 x 200 x 148 mm (5 5/8 x 7 7/8 x 5 7/8 inches) without projection	
Power requirements	DC 12 V			
Power consumption	21.6 W max.		18 W max	
Operating temperature	0 to 40°C (32 to 104°F)			
Storage temperature	-20 to 60°C (-4 to 140°F)			
Supplied accessories				
	AC power adaptor, AC power cord, Ceiling bracket (A), Ceiling bracket (B), Wire rope, Fixing screws (+PSW 3x6), Shoulder screw M4, I/O receptacle, Rubber foot, Clamp filter, CD-ROM (User's guide, setup program), Installation manual		Ceiling Bracket (A), Ceiling Bracket (B), Wire rope, Tapping screw(M3x6), CD-ROM (User's guide, supplied programs), Installation manual	
System requirements				
Operating system	Windows 98/98SE/Me/NT4.0/2000/XP		Windows 2000/XP	
Processor	CPU: Pentium III 500 MHz or higher (Pentium 4, 1GHz or higher recommended)		CPU: Pentium III 1 GHz or higher (Pentium IV, 2 GHz or higher recommended)	
Memory	RAM: 128 MB or more		RAM: 256 MB or more	
Web browser	Microsoft Internet Explorer® Ver.5.5 or 6.0			

SPECIFICATIONS

Network Cameras

	SNC-Z20N	SNC-Z20P	SNC-CS3N	SNC-CS3P
Camera				
Image device	1/4-type CCD with Exwave HAD technology		1/3-type CCD with Exwave HAD technology	
Number of effective pixels (H x V)	380,000 (768 x 494)	440,000 (752 x 582)	380,000 (768 x 494)	440,000 (752 x 582)
Electronic shutter	Auto/Manual			
Gain control	Auto/Manual			
Exposure control	Auto/Shutter-priority/Iris-priority/Manual/Backlight compensation		-	
White balance mode	Auto/ATW/Indoor/Outdoor/One push/Manual		ATW	
Lens type	Auto-focus zoom lens		Vari-focal auto iris lens	
Zoom ratio	18x Optical (12x Digital)		2.7x Optical	
Horizontal viewing angle	48 to 2.7 degrees		91 to 36 degrees	
Focal length	f=4.1 to 73.8 mm		f=3.0 to 8.0 mm	
F number	F1.4 (Wide), F3.0 (Tele)		F1.0 (Wide), F1.4 (Tele)	
Other functions	Day/Night, Image Flip, Activity Detection		Activity Detection	
Image				
Image size				
JPEG	736 x 480, 640 x 480, 320 x 240, 160 x 120	736 x 544, 640 x 480, 320 x 240, 160 x 120	736 x 480, 640 x 480, 320 x 240, 160 x 120	736 x 544, 640 x 480, 320 x 240, 160 x 120
Compression format	JPEG			
Maximum frame rate				
JPEG	30 fps (640 x 480)	25 fps (640 x 480)	30 fps (640 x 480)	25 fps (640 x 480)
Network				
Protocols	TCP/IP, ARP, ICMP, DHCP, NTP, DNS, HTTP, FTP, SMTP, SNMP (MIB2)			
Number of clients	50			
Interface				
Ethernet	100Base-TX/10Base-T (RJ-45)			
Serial interface	RS-232C			
Card slot	PC card Type II x 1			
Analog video output	BNC x 1, 1.0 Vp-p, 75 Ω, unbalanced, sync negative			
I/O port	Sensor in x 1, Alarm out x 2			
Analog video output				
Signal system	NTSC	PAL	NTSC	PAL
Horizontal resolution	480 TV lines	460 TV lines	480 TV lines	
S/N ratio	More than 50 dB (AGC OFF, Weight ON)			
Minimum illumination	Color: 0.7 lx (AGC ON, F1.4, 50IRE) B/W: 0.06 lx (AGC ON, F1.4, 50IRE)		0.5 lx (AGC ON, F1.0, 50IRE)	
General				
Mass	approx. 800 g (1 lb 12 oz)		approx. 650 g (1 lb 7 oz)	
Dimensions (W x H x D)	80 x 77 x 177 mm (3 1/4 x 3 1/8 x 7 inches)		70 x 57 x 199 mm (2 7/8 x 2 1/4 x 7 7/8 inches)	
Power requirements	AC 24 V (50/60 Hz), DC 12 V, Power Over Ethernet		AC 24 V (50/60Hz), DC 12 V	
Power consumption	9 W max		8 W	
Operating temperature	0 to 40°C (32 to 104°F)		-10 to 50°C (14 to 122°F)	
Storage temperature	-20 to 60°C (-4 to 140°F)			
Supplied accessories				
	CD-ROM (setup program, user's guide), Wire rope, Shoulder screw M4, Installation manual			
System requirements				
Operating system	Microsoft Windows 98/98SE/ME/NT4.0/2000XP			
Processor	Intel Pentium III, 500 MHz or higher (Intel Pentium 4, 1 GHz or higher recommended)			
Memory	RAM: 128 MB or more			
Web browser	Microsoft Internet Explorer version 5.5 or 6.0			

Network Cameras

	SNC-DF70N	SNC-DF70P	SNC-DF40N	SNC-DF40P
Camera				
Image device	1/4-type Super HAD CCD			
Number of effective pixels (H x V)	380,000 (768 x 494)	440,000 (752 X 582)	380,000 (768 x 494)	440,000 (752 X 582)
Gain control	Auto/Manual			
Exposure control	Auto/Manual, Backlight compensation			
White balance mode	ATW			
Lens type	CS-mount 2.7x Vari-focal auto iris lens			
Horizontal viewing angle	26.9 to 66.6 degrees			
Focal length	f=3.0 to 8.0 mm			
F number	F1.0 (Wide), F1.45 (Tele)		F1.0 (Wide), F1.4 (Tele)	
Other functions	Day/Night, Motion Detenction		Motion Detenction	
Image				
Image size				
JPEG	640 x 480, 480 x 360, 384 x 288, 320 x 240, 256 x 192, 160 x 120			
MPEG-4	640 x 480, 480 x 360, 384 x 288, 320 x 240, 256 x 192, 160 x 120			
Compression format	MPEG-4/JPEG(Selectable)			
Maximum frame rate				
JPEG	30 fps (320 x 240)	25 fps (320 x 240)	30 fps (320 x 240)	25 fps (320 x 240)
MPEG-4	30 fps (320 x 240)	25 fps (320 x 240)	30 fps (320 x 240)	25 fps (320 x 240)
Audio				
Compression format	G.711 (64 Kbps)G.726 (40, 32, 24, 16 Kbps)			
Network				
Protocols	TCP/IP, UDP, ARP, ICMP, DHCP, DNS, HTTP, FTP, SMTP, NTP, SNMP (MIB2), RTP/RTCP, PPPoE			
Number of clients	JPEG: 20, MPEG-4: 10			
Interface				
Ethernet	100Base-TX/10Base-T (RJ-45)			
Analog video output	BNC, 1.0 Vp-p, 75 Ω , unbalanced, sync negative			
I/O port	Sensor input x 1, Alarm output x 2			
External microphone input	Mini-jack (monaural), 4.7 k Ω , 2.5 V plug-in power			
Audio line output	Mini-jack (monaural), max output level: 1 Vrms			
Analog video output				
Signal system	NTSC	PAL	NTSC	PAL
Horizontal resolution	480 TV lines			
S/N ratio	more than 50 dB			
Minimum illumination	Color: 0.9 lx (AGC ON, F1.0, 50IRE), B/W: 0.2 lx (AGC ON, F1.0, 50IRE)		Color: 0.8 lx (F1.0, 50IRE, AGC ON)	
General				
Mass	approx. 1,500 g (3 lb 5 oz)		approx. 750 g (1 lb 10 oz)	
Dimensions (W x H x D)	165 x 135 x 166 mm (6 1/2 x 5 3/8 x 6 5/8 inches) without projection		124 x 132 x 126 mm (5 x 5 1/4 x 5 inches) without projection	
Power requirements	AC 24 V (50/60 Hz), DC 12 V, Power Over Ethernet			
Power consumption	8.0 W		7.5 W	
Operating temperature	-10 to +50°C (14 to 122°F)			
Storage temperature	-20 to +60°C (-4 to +140°F)			
Supplied accessories				
	Monitor cable, Wire rope, Screws, Dome cover screw, CD-ROM (User's guide, supplied programs), Installation manual		Monitor cable, Screws, Wrench, I/O extension cable, Wire rope, CD-ROM (User's guide, supplied programs), Installation manual	
System requirements				
Operating system	Microsoft Windows 2000/XP			
Processor	CPU: Pentium III, 1 GHz or higher (Pentium IV, 2 GHz or higher recommended)			
Memory	RAM: 256 MB or more			
Web browser	Microsoft Internet Explorer version 5.5 or 6.0			

SPECIFICATIONS

Network Cameras

	SNC-P5	SNC-P1
Camera		
Image device	1/4 type progressive scan CCD	
Number of effective pixels (H x V)	330,000 (659 x 494)	
Electronic shutter	Auto/Manual	
Gain control	Auto/Manual	
Exposure control	Auto/Shutter priority/ Manual	
White balance mode	ATW/Indoor/Outdoor/One push auto/Manual	
Lens type	Pan focus zoom lens	Fixed focal lens
Zoom ratio	3x optical	—
Horizontal viewing angle	55.8 to 20 degrees	53.4 degrees,
Focal length	F2.8 (Wide), F3.9 (Tele)	f=3.8 mm
F number	f3.4 to 10.2 mm	F2.0
Pan angle	-60 to +60 degrees	—
Tilt angle	-65 to +10 degrees	—
Other functions	Motion Detection	
Image		
Image size		
JPEG	640 x 480, 320 x 240, 160 x 120	
MPEG-4	640 x 480, 320 x 240, 160 x 120	
Compression format	MPEG-4, JPEG (Selectable)	
Maximum frame rate		
JPEG	30 fps (320 x 240)	
MPEG-4	30 fps (320 x 240)	
Audio		
Compression format	G.711(64KBps)/G.726 (40,32,24,16KBps)	
Built-in microphone	Electret condenser microphone (omni-directional)	
Network		
Protocols	TCP/IP, UDP,ARP, ICMP, DHCP, DNS, HTTP, FTP, SMTP, NTP, SNMP(MIB2), RTP/RTCP, PPPoE	
Number of clients	JPEG: 20, MPEG-4: 10	
Interface		
Ethernet	100Base-TX/10Base-T (RJ-45)	
Card slot	Compact Flash type x 1	—
Analog video output	Mini Jack, 1.0 Vp-p, 75 Ω, Sync negative	
I/O port	Sensor input x 2, Alarm output x 1	Sensor input x 1, Alarm output x 1
External microphone input	Mini-jack(monaural), 2.2k ohm, 2.5V plug-in power	
Audio line output	Mini-jack (monaural), max output level: 1 Vrms	
Analog video output		
Signal system	NTSC/PAL	
Horizontal Resolution	400 TV lines	
S/N ratio	more than 48 dB	
Minimum illumination	3.5 lx (AGC ON, F2.8, 30IRE)	1.2 lx (AGC ON, F2.0, 30IRE)
General		
Mass	Camera: approx. 380 g (13 oz), Stand: approx. 360 g (13 oz)	Camera: approx. 225 g (8 oz), Stand: approx. 180 g (6 oz)
Dimensions (W x H x D)	Camera: 130 x 130 x 110 mm (5 1/8 x 5 1/8 x 4 3/8 inches) without projection Stand: 130 x 178 x 142 mm (5 1/8 x 7 1/8 x 5 5/8 inches)	Camera: 100 x 36 x 139 mm (4 x 1 7/16 x 5 1/2 inches) without projection Stand: 120 x 142 x 150mm (4 3/4 x 5 5/8 x 6 inches)
Power requirements	DC12 V	
Power consumption	6.2 W max	3.5 W
Operating temperature	0 to +35°C (32 to 95°F)	
Storage temperature	-20 to +60°C (-4 to +140°F)	
Supplied accessories		
	AC power adaptor, AC Power cord, Stand, Wall-mount bracket, Rubber foot, Drop-prevention strap, Tapping screws, CD-ROM (user's guide, supplied programs), Installation manual	AC power adaptor, AC power cord, Stand, Wall-mount bracket, Rubber foot, Drop-prevention strap, Tapping screws, CD-ROM (user's guide, supplied programs), Installation manual
System requirements		
Operating system	Windows2000/ XP	
Processor	CPU: Pentium III 1 GHz or higher (Pentium IV, 2GHz or higher recommended)	
Memory	RAM : 256 MB or more	
Web browser	Internet Explorer Ver. 5.5 or 6.0	

Network Cameras

	SNC-M3	SNC-M3W	SNC-M1	SNC-M1W
Camera				
Image device	1/4-type CMOS			
Number of effective pixels (H x V)	310,000 (652 x 482)			
Electronic shutter	Auto			
Gain control	Auto			
Exposure control	Auto			
White balance mode	ATW			
Lens type	Fixed focal lens			
Zoom ratio	-			
Horizontal viewing angle	51.0 degrees			
Focal length	f=3.7 mm			
F number	F2.0			
Pan angle	+60 to -60 degrees		-	
Tilt angle	+10 to -60 degrees		-	
Minimum illumination	4.5 lx (AGC ON, F2.0, 30IRE)			
Other functions	Motion Detection			
Image				
Image size				
JPEG	640 x 480, 320 x 240, 160 x 120			
MPEG-4	640 x 480, 320 x 240, 160 x 120			
Compression format	MPEG-4/JPEG (Selectable)			
Maximum frame rate				
JPEG	30 fps (320 x 240)			
MPEG-4	30 fps (320 x 240)			
Audio				
Compression format	G.726 (40, 32, 24, 16 Kbps)			
Built-in microphone	Electret condenser microphone (Omni-directional)			
Network				
Protocols	TCP/IP, ARP, ICMP, DHCP, DNS, HTTP, FTP, SMTP, NTP			
Number of clients	10			
Wireless LAN				
Standard	-	IEEE802.11b (2.4 GHz)	-	IEEE802.11b (2.4 GHz)
Transmission speed	-	11 Mbps/5.5 Mbps/2 Mbps/1 Mbps (Auto Switch)	-	11 Mbps/5.5 Mbps/2 Mbps/1 Mbps (Auto Switch)
Security	-	WEP (64/128 bits)	-	WEP (64/128 bits)
Interface				
Ethernet	100Base-TX/10Base-T (RJ-45)			
External microphone input	Mini-jack (monoral), 2.2 kΩ, 2.5 V plug-in power			
Audio line output	Mini-jack (monaural), Max output level: 1 Vrms			
General				
Mass	Camera: approx. 350 g (12 oz) Stand: approx. 80 g (3 oz)	Camera: approx. 380 g (13 oz) Stand: approx. 80 g (3 oz)	Camera: approx. 250 g (9 oz) Stand: approx. 80 g (3 oz)	Camera: approx. 280 g (10 oz) Stand: approx. 80 g (3 oz)
Dimensions (W x H x D)	Camera: 110 x 104 mm (WxD) (4 3/8 x 4 1/8 inches) without projection Stand: 102 x 94 x 142 mm (4 1/8 x 3 3/4 x 5 5/8 inches)		Camera: 110 x 69 mm (DxH) (4 3/8 x 2 3/4 inches) without projection Stand: 102 x 94 x 142 mm (4 1/8 x 3 3/4 x 5 5/8 inches)	
Power requirements	DC 5 V			
Power consumption	5.5 W	8.2 W	2.9 W	5.2 W
Operating temperature	0 to +40°C (32 to 104°F)			
Storage temperature	-20 to +60°C (-4 to +140°F)			
Supplied accessories				
	AC power adaptor, AC power cord, Stand, Rubber foot, Drop-prevention strap, Tapping screws (4x20), CD-ROM (user's guide, supplied programs), Installation manual * For M3/M3W only: Wall-mount holder, Wall-mount bracket, +PSW screws (3x8)			
System requirements				
Operating system	Microsoft Windows 2000/XP			
Processor	CPU: Pentium III, 1 GHz or higher (Pentium IV, 2 GHz or higher recommended)			
Memory	RAM : 256 MB or more			
Web browser	Microsoft Internet Explorer version 5.5 or 6.0			

SPECIFICATIONS

Analog Cameras

	SSC-E473	SSC-E473P	SSC-E478P	SSC-E453	SSC-E453P	SSC-E458P
Camera						
Image device	1/3-type CCD with SuperExwave technology			1/3-type CCD with SuperExwave technology		
Number of effective pixels (H x V)	370,000 (768 x 494)	430,000 (752 x 582)		370,000 (768 x 494)	430,000 (752 x 582)	
Auto Gain Control	TURBO/OFF switchable					
White balance mode	ATW pro/ATW					
Lens type	CS-mount, DC servo auto iris					
CCD iris	ON/OFF switchable, 1/60 to 1/100,000 s	ON/OFF switchable, 1/50 to 1/100,000 s		ON/OFF switchable, 1/60 to 1/100,000 s	ON/OFF switchable, 1/50 to 1/100,000 s	
Back-Light Compensation (BLC)	ON/OFF switchable					
Day/Night function	Auto/External			-		
Analog video output	BNC x 1, 1.0 Vp-p, 75 Ω, Sync negative					
Signal system	NTSC	PAL		NTSC	PAL	
Sync system	Internal/AC Line lock		AC Line lock	Internal/AC Line lock		AC Line lock
Horizontal Resolution	540 TV lines					
S/N ratio	More than 50 dB (AGC OFF, WEIGHT ON)					
Minimum illumination	Color: 0.55 lx (50IRE, F1.2, Turbo AGC ON), B&W: 0.05 lx (50IRE, F1.2, Turbo AGC ON)			0.55 lx (50IRE, F1.2, AGC ON, Turbo mode)		
General						
Mass	approx. 380 g (13 oz), approx. 460 g (1 lb 1 oz)* including front and rear covers		approx. 400 g (14 oz), approx. 480 g (1 lb 8 oz)* including front and rear covers	approx. 360 g (12 oz), approx. 440 g (15 oz)* including front and rear covers		approx. 390 g (13 oz), approx. 470 g (1 lb)* including front and rear covers
Dimensions (W x H x D)	60 x 53 x 124 mm (2 3/8 x 2 1/8 x 5 inches), 60 x 53 x 246 mm (2 3/8 x 2 1/8 x 9 3/4 inches)* including front and rear covers			60 x 53 x 118 mm (2 3/8 x 2 1/8 x 4 3/4 inches), 60 x 53 x 240 mm (2 3/8 x 2 1/8 x 9 1/2 inches)* including front and rear covers		
Power requirements	AC 24 V ±10%, 60 Hz or DC 12 V ±10%	AC 24 V ±10%, 50 Hz or DC 12 V ±10%	AC 220 to 240 V ±10%, 50 Hz	AC 24 V ±10%, 60 Hz or DC 12 V ±10%	AC 24 V ±10%, 50 Hz or DC 12 V ±10%	AC 220 to 240 V ±10%, 50 Hz
Power consumption	4.0 W			3.5 W		
Operating temperature	-10 to 50°C (14 to 122°F)					
Storage temperature	-40 to 60°C (-40 to 140°F)					
Supplied accessories						
	Lens mount cap, Operating instructions, Front cover, Rear cover, Screws (2)		Lens mount cap, Operating instructions, Front cover, Rear cover, Screws (2). Power cable	Lens mount cap, Operating instructions, Front cover, Rear cover, Screws (2)		Lens mount cap, Operating instructions, Front cover, Rear cover, Screws (2). Power cable

	SSC-DC80	SSC-DC80P	SSC-DC83	SSC-DC83P	SSC-DC88P
Camera					
Image device	1/2-type CCD with Exwave HAD technology				
Number of effective pixels (H x V)	370,000 (768 x 494)	430,000 (752 x 582)		370,000 (768 x 494)	430,000 (752 x 582)
Auto Gain Control	Turbo/Normal/Manual/Off				
White balance mode	ATW-pro/ATW/3200K/5600K/Manual				
Lens type	CS/C*-mount (* C-mount adaptor is supplied), DC/Video servo auto iris				
CCD iris	ON/OFF switchable, 1/60 to 1/100,000 s	ON/OFF switchable, 1/50 to 1/100,000 s	ON/OFF switchable, 1/60 to 1/100,000 s	ON/OFF switchable, 1/50 to 1/100,000 s	
Back-Light Compensation (BLC)	SPOT/WEIGHT/OFF switchable				
Analog video output	BNC x 1, 1.0 Vp-p, 75 Ω, Sync negative, S-Video x 1				
Signal system	NTSC	PAL		NTSC	PAL
Sync system	Internal/VS/VD		Internal/AC Line lock/VS		
Horizontal Resolution	480 TV lines				
S/N ratio	More than 57 dB (AGC OFF, WEIGHT ON)				
Minimum illumination	0.4 lx (50IRE, F1.2, Turbo AGC ON)				
General					
Mass	approx. 560 g (1.4 oz)		approx. 550 g (1.3 oz)		approx. 600 g (1.5 oz)
Dimensions (W x H x D)	70 x 57 x 260 mm (2 7/8 x 2 1/4 x 20 1/4 inches) (including front and rear covers)				
Power requirements	Multiplexing with the YS-W170A/W270A, or DC 12 V ±10 %	Multiplexing with the YS-W170P/W270P, or DC 12 V ±10 %	AC 24 V ±10 %, 60 Hz or DC 12 V ±10 %	AC 24 V ±10 %, 50 Hz or DC 12 V ±10 %	AC 220 to 240 V ±10 %, 50 Hz
Power consumption	4.6 W		4.4 W		4.2 W
Operating temperature	-10 to 50°C (14 to 122°F)				
Storage temperature	-40 to 60°C (-40 to 140°F)				
Supplied accessories					
	Lens mount cap, Operating instructions, Front cover, Rear cover, Screws (2), C-mount adaptor				Lens mount cap, Operating instructions, Front cover, Rear cover, Screws (2), Power cable

Analog Cameras

	SSC-DC590	SSC-DC593	SSC-DC593P	SSC-DC598P
Camera				
Image device	1/3-type CCD with DynaView technology			
Number of effective pixels (H x V)	370,000 (768 x 494)		430,000 (752 x 582)	
Auto Gain Control	NORMAL/TURBO/MANUAL/OFF selectable			
White balance mode	ATW pro/ATW/3200K/5600K/MANUAL/DUAL WB selectable			
Lens type	CS-mount, DC/Video servo auto iris			
CCD iris	ON/OFF switchable, 1/60 to 1/100,000 s		ON/OFF switchable, 1/50 to 1/100,000 s	
Back-Light Compensation (BLC)	DYNVIEW/SPOT/WEIGHT/OFF selectable			
Day/Night function	Auto/External/Color/B&W selectable			
Analog video output	BNC x 1, 1.0 Vp-p, 75 Ω, Sync negative			
Signal system	NTSC		PAL	
Sync system	Internal/VS/VD		Internal/AC Line lock	
Horizontal Resolution	480 TV lines			
S/N ratio	More than 50 dB (AGC OFF, WEIGHT ON)			
Minimum illumination	Color: 0.8 lx (50IRE, F1.4, Turbo AGC ON), B&W: 0.07 lx (50IRE, F1.4, Turbo AGC ON)			
General				
Mass	approx. 500 g (1 lb 2 oz)			
Dimensions (W x H x D)	70 x 57 x 129 mm (2 7/8 x 2 1/4 x 5 1/8 inches)			
Power requirements	Multiplexing with the YS-W170A/W270A or DC 12 V ±10%	AC 24 V ±10%, 60 Hz or DC 12 V ±10%	AC 24 V ±10%, 50 Hz or DC 12 V ±10%	AC 220 to 240 V ±10%, 50 Hz
Power consumption	5.8 W			5.6 W
Operating temperature	-10 to 50°C (14 to 122°F)			
Storage temperature	-40 to 60°C (-40 to 140°F)			
Supplied accessories				
	Lens mount cap, Operating instructions, Menu operations			Lens mount cap, Operating instructions, Menu operations, AC power cable

	SSC-DC573	SSC-DC573P	SSC-DC578P
Camera			
Image device	1/3-type CCD with DynaView technology		
Number of effective pixels (H x V)	370,000 (768 x 494)		430,000 (752 x 582)
Auto Gain Control	NORMAL/TURBO/MANUAL/OFF selectable		
White balance mode	ATW pro/ATW/3200K/5600K/MANUAL/DUAL WB selectable		
Lens type	CS-mount, DC/Video auto iris		
CCD iris	ON/OFF switchable, 1/60 to 1/100,000 s		ON/OFF switchable, 1/50 to 1/100,000 s
Back-Light Compensation (BLC)	DYNVIEW/SPOT/WEIGHT/OFF selectable		
Day/Night function	-		
Analog video output	BNC x 1, 1.0 Vp-p, 75 Ω, Sync negative		
Signal system	NTSC		PAL
Sync system	Internal/AC Line lock		
Horizontal Resolution	480 TV lines		
S/N ratio	More than 50 dB (AGC OFF, WEIGHT ON)		
Minimum illumination	0.8 lx (50IRE, F1.4, Turbo AGC ON)		
General			
Mass	approx. 480 g (1 lb 1 oz)		
Dimensions (W x H x D)	70 x 57 x 129 mm (2 7/8 x 2 1/4 x 5 1/8 inches)		
Power requirements	AC 24 V ±10%, 60 Hz or DC 12 V ±10%	AC 24 V ±10%, 50 Hz or DC 12 V ±10%	AC 220 to 240 V ±10%, 50 Hz
Power consumption	4 W		
Operating temperature	-10 to 50°C (14 to 122°F)		
Storage temperature	-40 to 60°C (-40 to 140°F)		
Supplied accessories			
	Lens mount cap, Operating instructions, Menu operations		Lens mount cap, Operating instructions, Menu operations, AC power cable

SPECIFICATIONS

Analog Color Cameras

	SSC-DC374	SSC-DC372P	SSC-DC378P
Camera			
Image device	1/3-type Super HAD CCD		
Number of effective pixels (H x V)	370,000 (768 x 494)	430,000 (752 x 582)	
Auto Gain Control	TURBO/OFF switchable		
White balance mode	ATW		
Lens type	CS-mount, DC servo auto iris		
CCD iris	ON/OFF switchable, 1/60 to 1/100,000 s	ON/OFF switchable, 1/50 to 1/100,000 s	
Back-Light Compensation (BLC)	ON/OFF switchable		
Analog video output	BNC x 1, 1.0 Vp-p, 75 Ω, Sync negative		
Signal system	NTSC	PAL	
Sync system	AC Line lock	Internal	AC Line lock
Horizontal Resolution	480 TV lines		
S/N ratio	More than 50 dB (AGC OFF, WEIGHT ON)		
Minimum illumination	0.8 lx (50IRE, F1.2, Turbo AGC ON)		
General			
Mass	approx. 355 g (13 oz)	approx. 385 g (14 oz)	
Dimensions (W x H x D)	60 x 54 x 120 mm (2 3/8 x 2 1/4 x 4 3/4 inches)		
Power requirements	AC 24 V ±10%, 60 Hz	DC 12 V ±10 %	AC 220 to 240 V ±10%, 50 Hz
Power consumption	3.6 W	3.2 W	4.0 W
Operating temperature	-10 to 50°C (14 to 122°F)		
Storage temperature	-40 to 60°C (-40 to 140°F)		
Supplied accessories			
	Lens mount cap, Operating instructions		Lens mount cap, Operating instructions, AC power cable

	SSC-DC193	SSC-DC193P	SSC-DC198P	SSC-DC174	SSC-DC172P	
Camera						
Image device	1/3-type Super HAD CCD					
Number of effective pixels (H x V)	250,000 (510 x 492)	290,000 (500 x 582)		250,000 (510 x 492)	290,000 (500 x 582)	
Auto Gain Control	TURBO/OFF switchable					
White balance mode	ATW					
Lens type	CS-mount, DC/Video servo auto iris			CS-mount, DC/Video servo auto iris		
CCD iris	TURBO/OFF switchable, 1/60 to 1/100,000 s	ON/OFF switchable, 1/50 to 1/100,000 s		ON/OFF switchable, 1/60 to 1/100,000 s	ON/OFF switchable, 1/50 to 1/100,000 s	
Back-Light Compensation (BLC)	ON/OFF switchable					
Analog video output	BNC x 1, 1.0 Vp-p, 75 Ω, Sync negative					
Signal system	NTSC	PAL		NTSC	PAL	
Sync system	Internal/AC Line lock		AC Line lock	Internal/AC Line lock	Internal	
Horizontal Resolution	330 TV lines					
S/N ratio	More than 50 dB (AGC OFF, WEIGHT ON)					
Minimum illumination	0.6 lx (50IRE, F1.2, Turbo AGC ON)					
General						
Mass	approx. 360 g (13 oz)		approx. 390 g (14 oz)	approx. 355 g (12 oz)		
Dimensions (W x H x D)	60 x 54 x 120 mm (2 3/8 x 2 1/4 x 4 3/4 inches)			60 x 54 x 120 mm (2 3/8 x 2 1/4 x 4 3/4 inches)		
Power requirements	AC 24 V ±10%, 60 Hz or DC 12 V ±10 %	AC 24 V ±10%, 50 Hz or DC 12 V ±10 %	AC 220 to 240 V ±10%, 50 Hz	AC 24 V ±10%, 60 Hz	DC 12 V ±10%	
Power consumption	3.5 W		3.7 W	3.4 W		
Operating temperature	-10 to 50°C (14 to 122°F)					
Storage temperature	-40 to 60°C (-40 to 140°F)					
Supplied accessories						
	Lens mount cap, Operating instructions			Lens mount cap, Operating instructions, AC power cable	Lens mount cap, Operating instructions	

Analog Cameras (B/W)

	SSC-M383	SSC-M383CE	SSC-M388CE	SSC-M183	SSC-M183CE	SSC-M188CE
Camera						
Image device	1/3-type CCD with Exwave HAD technology					
Number of effective pixels (H x V)	370,000 (768 x 494)	430,000 (752 x 582)		250,000 (510 x 492)	291,000 (500 x 582)	
Auto Gain Control	TURBO/OFF switchable					
White balance mode	ATW					
Lens type	CS-mount, DC/Video servo auto iris					
CCD iris	ON/OFF switchable, 1/60 to 1/100,000 s	ON/OFF switchable, 1/50 to 1/100,000 s		ON/OFF switchable, 1/60 to 1/100,000 s	ON/OFF switchable, 1/50 to 1/100,000 s	
Back-Light Compensation (BLC)	ON/OFF switchable					
Analog video output	BNC x 1, 1.0 Vp-p, 75 Ω, Sync negative					
Signal system	EIA	CCIR		EIA	CCIR	
Sync system	Internal/AC Line lock		AC Line lock	Internal/AC Line lock		AC Line lock
Horizontal Resolution	570 TV lines			380 TV lines		
S/N ratio	More than 50 dB (AGC OFF, WEIGHT ON)					
Minimum illumination	0.07 lx (50IRE, F1.2, Turbo AGC ON)			0.06 lx (50IRE, F1.2, Turbo AGC ON)		
General						
Mass	approx. 360 g (13 oz)		approx. 390 g (14 oz)	approx. 360 g (13 oz)		approx. 390 g (14 oz)
Dimensions (W x H x D)	60 x 54 x 120 mm (2 3/8 x 2 1/4 x 4 3/4 inches)					
Power requirements	AC 24 V ±10%, 60 Hz or DC 12 V ±10%	AC 24 V ±10%, 50 Hz or DC 12 V ±10 %	AC 220 to 240 V ±10 %, 50 Hz	AC 24 V ±10%, 60 Hz or DC 12 V ±10%	AC 24 V ±10%, 50 Hz or DC 12 V ±10%	AC 220 to 240 V ±10 %, 50 Hz
Power consumption	2.6 W			2.5 W		
Operating temperature	-10 to 50°C (14 to 122°F)					
Storage temperature	-40 to 60°C (-40 to 140°F)					
Supplied accessories						
	Lens mount cap, Operating instructions		Lens mount cap, Operating instructions, AC power cable	Lens mount cap, Operating instructions		Lens mount cap, Operating instructions, AC power cable

Analog Cameras

	SSC-CD73V	SSC-CD73VP	SS-CD73VT	SSC-CD43V	SSC-CD43VP	SSC-CD43VT
Camera						
Image device	1/4-type Super HAD CCD					
Number of effective pixels (H x V)	370,000 (768 x 494)	430,000 (752 x 582)	370,000 (768 x 494)		430,000 (752 x 582)	370,000 (768 x 494)
Auto Gain Control	TURBO/OFF switchable					
White balance mode	ATW					
Lens type	Vari-focal lens, CS-mount, DC servo auto iris					
Focal length	f=3.0 to 8.0 mm					
View angle	W=84.6°(D), 66.6°(H), 49.3°(V) T=33.8°(D), 27°(H), 20.2°(V)			W=84.7°(D), 66.6°(H), 49.3°(V) T=33.6°(D), 26.9°(H), 20.1°(V)		
CCD iris	ON/OFF switchable, 1/60 to 1/100,000 s	ON/OFF switchable, 1/50 to 1/100,000 s	ON/OFF switchable, 1/60 to 1/100,000 s		ON/OFF switchable, 1/50 to 1/100,000 s	ON/OFF switchable, 1/60 to 1/100,000 s
Minimum object distance	0.2 m					
Back-Light Compensation (BLC)	ON/OFF switchable					
Analog video output	BNC x 1, 1.0 Vp-p, 75 Ω, Sync negative		UTP x 1, 1.0 Vp-p, 100 Ω, Sync negative	BNC x 1, 1.0 Vp-p, 75 Ω, Sync negative		UTP x 1, 1.0 Vp-p, 100 Ω, Sync negative
Signal system	NTSC	PAL	NTSC		PAL	NTSC
Sync system	Internal/AC Line lock					
Horizontal Resolution	480 TV lines		–	480 TV lines		–
S/N ratio	More than 50 dB (AGC OFF, WEIGHT ON)					
Minimum illumination	Color: 0.9 lx (50IRE, F1.0, AGC ON), B&W: 0.2 lx (50IRE, F1.0, AGC ON)			Color: 0.8 lx (50IRE, F1.0, AGC ON)		
General						
Mass	approx. 1,150 g (2 lb 10 oz)			approx. 440 g (16 oz)		
Dimensions (W x H x D)	147 x 111 x 148 mm (5 7/8 x 4 3/8 x 5 7/8 inches)			121 x 107 x 123 mm (4 7/8 x 4 1/4 x 4 7/8 inches)		
Power requirements	AC 24 V ±10%, 60 Hz or DC 12 V ±10%	AC 24 V ±10%, 50 Hz or 12 V ±10%	AC 24 V ±10%, 60 Hz or DC 12 V ±10%		AC 24 V ±10%, 50 Hz or 12 V ±10%	AC 24 V ±10%, 60 Hz or 12 V ±10%
Power consumption	3.6 W			3.3 W		
Operating temperature	-20 to 50°C (-4 to 122°F)					
Storage temperature	-40 to 60°C (-40 to 140°F)					
Supplied accessories						
	Screw TP4 x 30 (4), Monitor cable, Screwdriver, External control terminal connector, Operating Instructions			Screw TP4 x 30 (2), Dome cover screw, Monitor cable, Operating Instructions		

SPECIFICATIONS

Camera Adaptors

	YS-W270A	YS-W270P	YS-W170A	YS-W170P
Video output	BNC(8), composite video		BNC(2), composite video	
Signal system	NTSC	PAL	NTSC	PAL
Video input	Camera in, BNC(4)		Camera in, BNC(1)	
External sync	VS or VD-W			
Internal sync	MPX-VS or MPX-VD-W			
Max. cable length	300 m (984 ft) using RG-59B/U 500 m (1640 ft) using RG-6A/U 600 m (1968 ft) using RG-11A/U			
Cable compensation	3 positions			
Power requirements	AC 120 V, 60 Hz	AC 220 to 240 V, 50 Hz	AC 120 V, 60 Hz	AC 220 to 240 V, 50 Hz
Power consumption	92 W	49.5 W	27 W	15 W
Operating temperature	-10 to 50°C (14 to 122°F)			
Mass	3.8 kg (8 lb 6 oz)		1.9 kg (4 lb 3 oz)	
Dimensions (W x H x D)	424 x 52 x 345 mm (16 3/4 x 2 1/8 x 13 5/8 inches)		212 x 52 x 345 mm (8 3/8 x 2 1/8 x 13 5/8 inches)	

Systems and Software

XIS-10DC	
Pan/Tilt/Zoom Camera	
Image device	1/6-type Interline Transfer Super HAD CCD
Number of effective pixels	630,000 pixels
Electronic shutter	1 to 1/10,000 s
White balance mode	Auto/Manual
Lens type	Auto-focus zoom lens
Zoom ratio	x25 optical zoom
Horizontal viewing angle	Horizontal: 2.0 to 45 degrees
Focal length	f=2.4 to 60 mm
F number	F1.6 (wide), F2.7 (tele)
Iris	Auto/Manual (F1.6 to close)
Pan angle	-170 to +170 degrees
Tilt angle	-17 to +38 degrees (effective)*1
Other functions	Day/Night, Image stabilizer, Position preset
Compression format	JPEG
Compression ratio	approx. 1/5 to 1/60 (10 steps)
Frame rate	10 fps (640 x 480)
S/N ratio	48 dB
Minimum illumination (Color)	2.5 lx (50IRE, F1.6: AE mode, slow shutter off)
Sensor (360 degree) Camera	
Circular angle of view	Elevation: 17 degrees Depression: 38 degrees
Total number of pixel	1,340,000 pixels
Frame rate	7.5 fps
System Requirements (for Application Software)	
Operating system	Windows XP Professional
Processor	CPU: Pentium IV 3 GHz or higher
Memory	RAM: 1 GB or more
HDD	100 GB required, 500 GB recommended
Video Card	1024 x 768 or greater
Network	100 Mb/s or more
Display	Full-color display
Interface	
Ethernet	RJ-45 (100Base-TX/10Base-T)
General	
Mass	
Main unit	12 kg (26 lb 7 oz)
Main unit with adaptor arm	17.8 kg (39 lb 4 oz)
Dimensions (W x H x D)	
Main unit	347 x 540 x 347 mm (13 3/4 x 21 3/8 x 13 3/4 inches)
Main unit with adaptor arm	347 x 540 x 736 mm (13 3/4 x 21 3/8 x 29 inches)
Power requirements	12 V DC
Power consumption	140 W
Operating temperature	-10 to 40°C (14 to 104°F), when air conditioning system is on
Storage temperature	-20 to 60°C (-4 to 140°F)
Operating humidity	20 to 90%, Non-condensing, when air conditioning systems is on
Storage humidity	20 to 95%, Non-condensing
Dust/Water Protection	IEC529 (IP66 rated)
Supplied accessories	
CD-ROM (Application Software, Housing, Adaptor arm, Operation manual)	

*1 Tilt range is limited by application software.

Systems and Software

IMZ-RS300 Series	
Intelligent Monitoring Software	
Operating system*	Windows 2000, Windows XP or Windows 2003 Server
Processor	CPU: Pentium IV 2.4 GHz or higher
Memory	RAM: 512 MB or more
HDD	2 GB spare capacity
Video Card	1024 x 768, 16/24-bit color
Network Interface Card (NIC)	100Base-T
Display	Full-color display
Web Gateway	
Operating system	Windows 2000 or Windows XP
Java Runtime**	Java Runtime Environment 1.4.2
Web Application Server**	Apache Tomcat 5.0.18
Web Browser	Internet Explorer Version 6.0 or later
Processor	CPU: Pentium IV 2.4 GHz or higher
Memory	RAM: 512 MB or more
HDD	500 MB spare capacity
Video Card	1024 x 768, 16/24-bit color
Network Interface Card (NIC)	100Base-T
Compression Server	
Operating system	Windows 2000 or Windows XP
Processor	CPU: Pentium IV 2.4 GHz or higher
Memory	RAM: 512 MB or more
HDD	500 MB spare capacity
Video Card	1024 x 768, 16/24-bit color
Network Interface Card (NIC)	100Base-T
Intelligent Monitoring Software Web Viewer	
Operating system	Windows 2000 or Windows XP
Java Runtime***	Java Runtime Environment 1.4.2
Web Browser	Internet Explorer Version 6.0 or Later
Processor	CPU: Celeron 2.0 GHz or higher
Memory	RAM: 512 MB or more
HDD	500 MB spare capacity
Video Card	1024 x 768, 16/24-bit color
Network Interface Card (NIC)	100Base-T

* Please contact your local Sony office or authorized dealer for compatibility information on the Linux Operating System.

** Both Java Runtime Environment and Web Application Server are included in the Web Gateway Module. *** Downloadable from Web Gateway.

Video Network Station

	SNT-V504	SNT-V501
Analog Video Interface		
Video input	Analog composite (BNC x 4), 1.0 Vp-p, 76 Ω, unbalanced, sync negative. Auto sensing for NTSC or PAL	Analog composite (BNC x 1), 1.0 Vp-p, 75 Ω, unbalanced, sync negative. Auto sensing for NTSC or PAL
Video output	Analog composite (BNC x 1), 1.0 Vp-p, 76 Ω, unbalanced, sync negative (QUAD/Single selectable)	Through video output: Analog composite (BNC x 1), 1.0 Vp-p, 75 Ω, unbalanced, sync negative
System/Network		
CPU	32-bit RISC processor	
RAM	32 MB (including 8 MB alarm buffer)	
Flash memory	8 MB	
Image size		
NTSC	704 x 480, 640 x 480, 320 x 240, 160 x 120	
PAL	704 x 544, 640 x 480, 320 x 240, 160 x 120	
Compression method	JPEG	
Compression ratio	Approx. 1/5 to 1/60 (10 steps)*	
Frame rate		
NTSC	Max. 30 fps (640 x 480)	
PAL	Max. 25 fps (640 x 480)	
Protocols	TCP/IP, ARP, ICMP, HTTP, FTP (client/server), SMTP, DHCP, DNS, NTP, SNMP (MIB-2)	
Number of clients	Maximum of 50	
Interface		
Ethernet	100Base-TX/10Base-T (RJ-45)	
Sensor input	(4) 3.3 to 24 V DC devices supported, photo coupler inputs electrically isolated from this unit	(1) 3.3 to 24 V DC device supported, photo coupler inputs electrically isolated from this unit
Alarm output	(2) 24 V DC or less, 1 A, mechanical relay outputs electrically isolated from the camera	
Serial interface	RS-485/RS-232C (for camera control or transparency function)	
PC card slot	PC card Type II x 2	
General		
Mass	Approx. 710 g (1 lb 9 oz)	Approx. 650 g (1 lb 7 oz)
Dimensions (W x H x D)	128 x 40 x 150 mm (5 1/8 x 1 5/8 x 6 inches)	
Power requirements	DC 12V or AC 24 V	
Power consumption	14.0 W max.	10.0 W max.
Operating temperature	-10 to 50°C (14 to 122°F) When PC card is attached: -10 to 40°C (14 to 104°F)	
Storage temperature	-20 to 60°C (-4 to 140°F)	
Operating humidity	20 to 80%, Non-condensing	
Storage humidity	20 to 95%, Non-condensing	
Supplied accessories		
	CD-ROM (setup program and User's Guide) (1), I/O receptacle (1), Installation manual (1)	

* The compression ratio is based on an image of 24 bits/picture element (8 bits each for R, G, and B)

SPECIFICATIONS

Digital Hard Disk Recorder

	HSR-X206	HSR-X206P
Video		
Input	6 channels, VBS, VS (BNC) 1.0 Vp-p, 75 Ω , unbalanced	
Output (Loop through)	6 channels, VBS, VS (BNC) 1.0 Vp-p, 75 Ω , unbalanced	
Monitor output 1	1 channel, VBS, VS (BNC) 1.0 Vp-p, 75 Ω , unbalanced	
Monitor output 2	1 channel, VBS, VS (BNC) 1.0 Vp-p, 75 Ω , unbalanced	
Video compression	Motion-JPEG	
Picture quality mode	HYPER: 52 kB/picture, SUPER: 44 kB/picture, HIGH: 32 B/picture, MID: 24 kB/picture, LOW: 17 kB/picture	
Picture resolution	720 x 240 pixels (Field mode)	720 x 288 pixels (Field mode)
Horizontal resolution	More than 500 TV lines (Hyper mode)	
Signal to noise ratio	48 dB (typical, Hyper mode)	
Audio		
MIC input	1 channel monaural (Mini jack), -60 dB, 10 k Ω , unbalanced	
Line input	1 channel monaural (Phono jack), -8 dB, 27 k Ω , unbalanced	
Line output	1 channel Monaural (Phono jack), -8 dB, 600 Ω , unbalanced	
Signal to noise ratio	40 dB (typical)	
Distortion	Less than 4 % at 1 kHz	
Network Interface		
Ethernet	100Base-TX/10Base-T	
Alarm and Control Inputs/Outputs		
Alarm in 1-6	Normal open, Low active	
Sensor Alarm out 1-6	Open collector, Low active	
Remote 1/Remote 2	2-wire type with resistance-based identification system	
Alarm out	Open collector, Low active	
Alarm reset	Incl. video loss reset, normal open, Low active	
Clock set in	Normal open, Low active	
Clock set out	5 V/5.7 k Ω , Low active	
Non rec out	Video loss alarm selectable, 5V/5.7 k Ω , Low active	
Warning out	5 V/5.7 k Ω , Low active	
Disk full out	5 V/5.7 k Ω , Low active	
Alarm full out	5 V/5.7 k Ω , Low active	
External timer in	Normal open, Low active	
General		
Mass	6.4 kg (14 lb 1 oz)	
Dimensions (W x H x D)	420 x 96 x 376 mm (16 ⁵ / ₈ x 3 ⁷ / ₈ x 14 ⁷ / ₈)	
Power requirements	AC 120 V, 60 Hz	AC 220 V, 50/60 Hz
Power consumption	32 W	
Operating temperature	5 to 40°C (41 to 104°F)	
Operating Humidity	Less than 80%	
HDD capacity	320 GB (160 GB x 2)	
Supplied accessories		
	AC power cord (1), Power cord tie (1), Rack mount kit (1), Operation Manual (1), Ferrite core (HSR-X206 (2), HSR-X206P (4))	

Monitor

	LMD-1410	LMD-2010
Picture Performance		
LCD Panel	14-inch LCD Monitor	20-inch LCD Monitor
Type	a-Si TFT Active Matrix LCD	
Resolution	640 x 480 dots	
Pixel efficiency	99.99%	
Dot pitch		
Picture Size (H x W) (Diagonal)	Approx. 283.2 x 212.4 mm (11 1/4 x 8 3/8 inches) 13.94 inches (354 mm)	Approx. 408.0 x 306.0 (16 1/8 x 12 1/8 inches) 20.1 inches (510 mm)
Aspect	4:3	
Colors	16,770,000 colors	
Viewing Angle	85°/85°/85°/85° (typical) (up/down/left/right contrast>10:1)	
Input/Output		
Input		
Line A	Composite (BNC x 1), Y/C (Mini DIN 4-pin x 1), Audio in (phono jack x 1)	
Line B	Composite (BNC x 1), Audio in (phono jack x 1) Component or RGB (BNC x 3), Audio in (phono jack x 1)	
Remote Parallel	Modular 8-pin	
Output		
Line A	Composite (BNC x 1, automatic 75 Ω termination), Y/C (Mini DIN 4-pin x 1, automatic 75 Ω termination), Audio in (phono jack x 1)	
Line B	Composite (BNC x 1, automatic 75 Ω termination), Component or RGB (BNC x 3, automatic 75 Ω termination), Audio in (phono jack x 1)	
Audio Output	0.5 W	
General		
Power Consumption	Approx. 50 W	Approx. 86 W
Power requirement	AC100 to 240V, 50/60Hz	
Operating Temperature	0 to 35°C	
Operating Humidity	30 to 85% (no condensation)	
Storage & Transport Temperature	-10 to 40°C	
Storage & Transport Humidity	0 to 90%	
Operating/Storage/Trans. Pressure	700 to 1060 hPa	
Dimensions (W x H x D)		
Dimension with stand	Approx. 343 x 352 x 265 mm (13 5/8 x 13 7/8 x 10 1/2 inches)	Approx. 470 x 440 x 265 mm (18 5/8 x 17 3/8 x 10 1/2 inches)
Dimension without stand	Approx. 343 x 304 x 87mm (13 5/8 x 12 x 3 1/2 inches)	Approx. 470 x 394 x 87mm (18 5/8 x 15 5/8 x 2 inches)
Mass		
Panel & Stand	Approx. 6.9 Kg (15 lb 3 oz)	Approx. 9.7 Kg (21 lb 6 oz)
Panel only	Approx. 5.2 kg (11 lb 7 oz)	Approx. 8.0 kg (17 lb 10 oz)

SYSTEM CONFIGURATIONS

Analog Cameras

Single Camera Operation

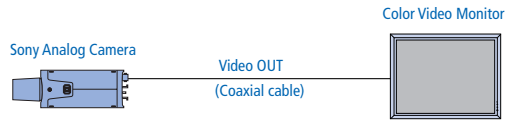

Single Camera Operation (Using the YS-W170A/W170P Camera Adaptor)

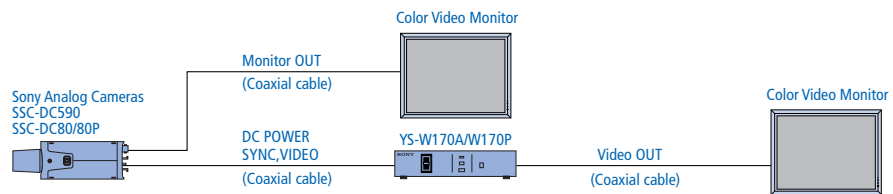

Multiple Camera Operation

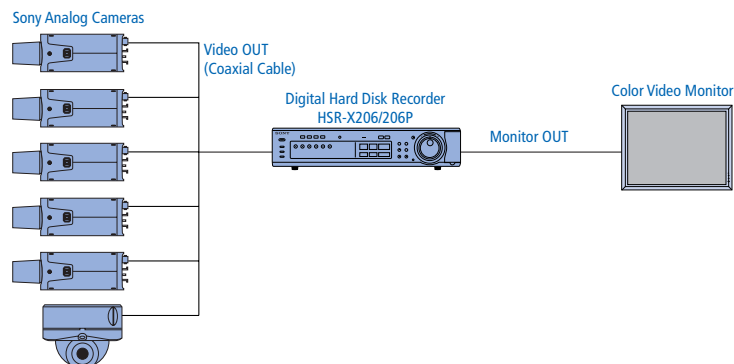

Multiple Camera Operation (Using the YS-W270A/W270P Camera Adaptor)

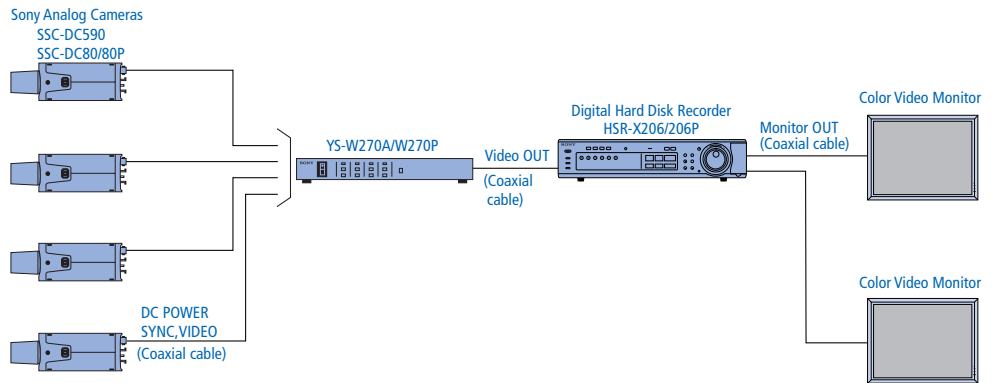

Multiple Camera Operation over Network (Using the SNT-V504)

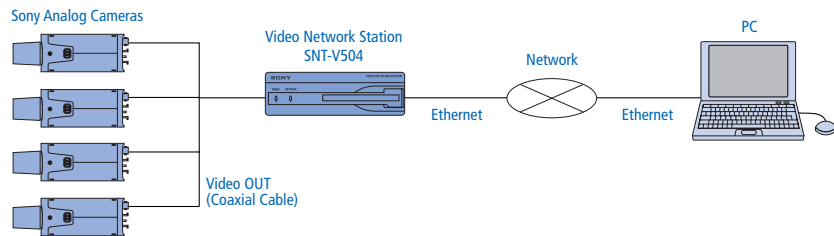

Multiple Camera Operation over Network (Using the HSR-X206/X206P)

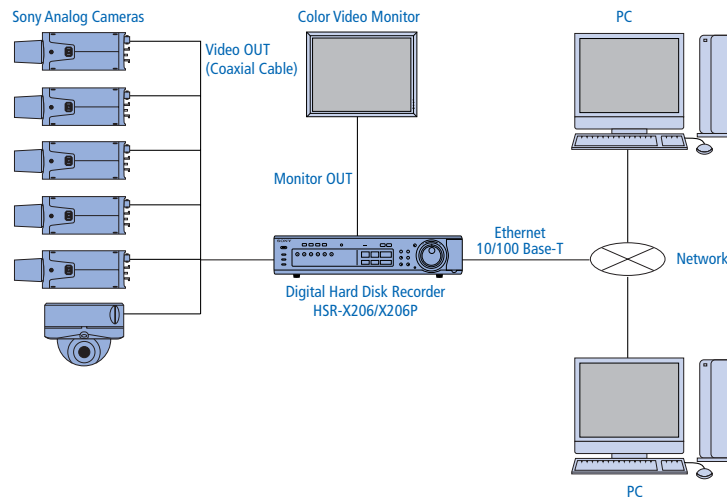

SYSTEM CONFIGURATIONS

Network Cameras

Single or Multiple Camera Operation

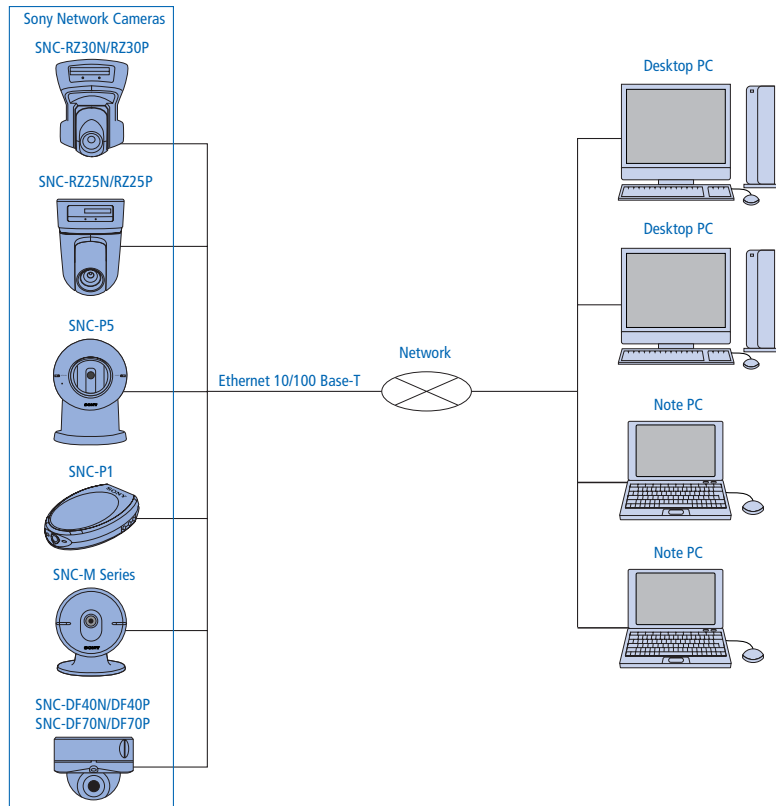

IMZ-RS300 Series Operation

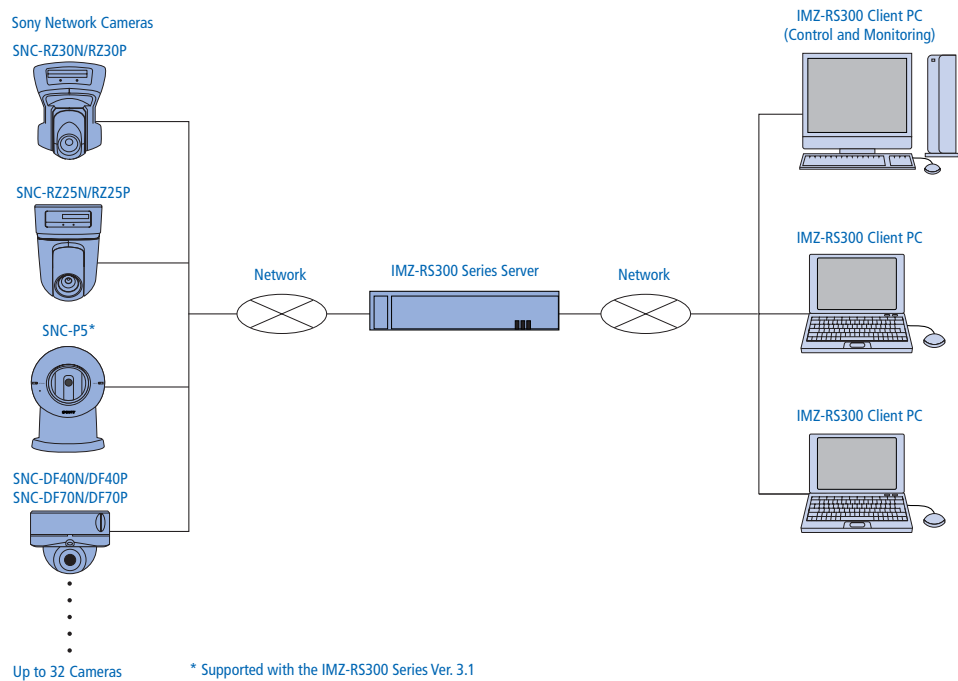

Network Cameras

Single and Multiple Camera Operation

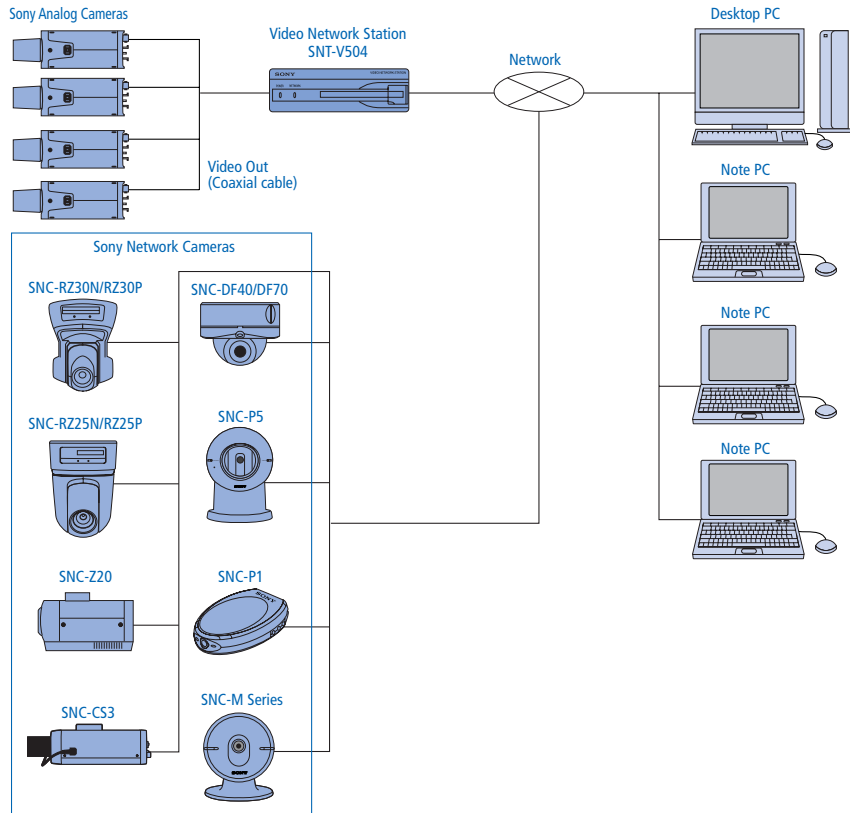

IMZ-RS300 Series Operation

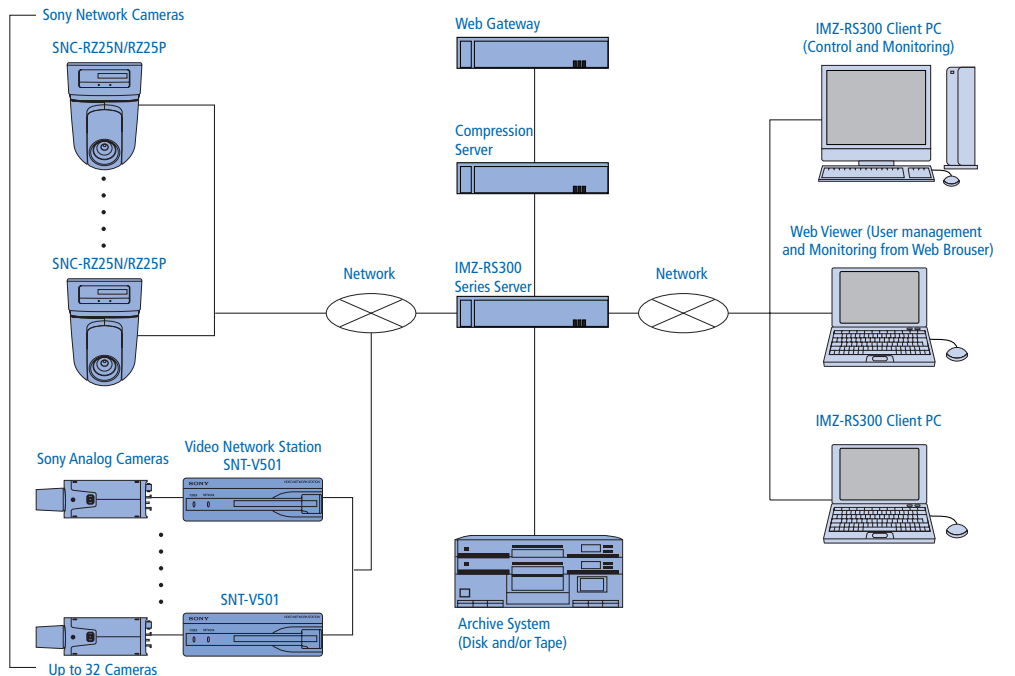

SYSTEM CONFIGURATIONS

IP and Analog Cameras

XIS-10DC Operation

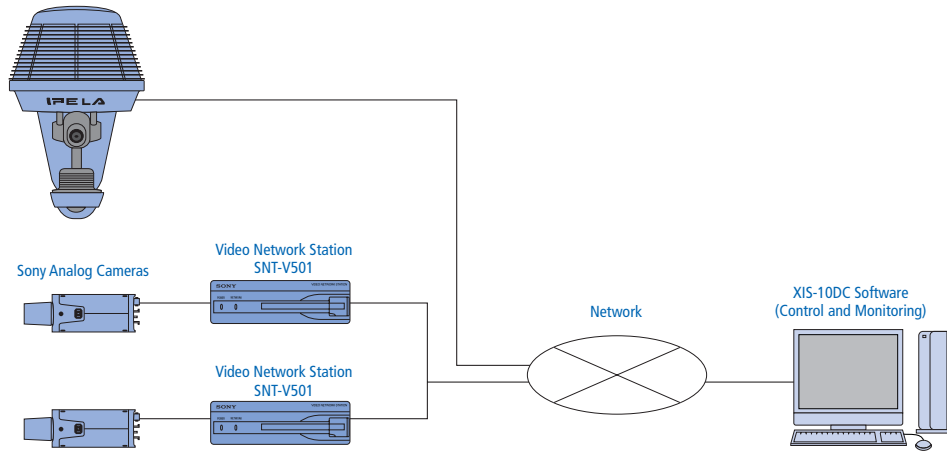

GLOSSARY

Activity Detection

A method of detecting activity in an image. Activity detection compares illumination levels between frames on a pixel-by-pixel basis. If the average change in luminance level from one frame to the next is greater than a pre-specified threshold, then an alarm is triggered.

Automatic Gain Control (AGC)

Amplifies existing video to help camera reproduce a video signal at very low light levels.

Adaptive Picture Control (APC)

Automatically detects the condition of the recording head and video cassette tape and then sets the optimum recording head current. Available on all SVT time lapse VCRs.

Adaptive Rate Control (ARC)

A technology that automatically detects and compensates for network traffic when transferring MPEG-4 image data over a network. In order to prevent "Drop Outs" when the network becomes congested, ARC first lowers the data bit rate, and if the network is still congested, then ARC lowers the frame rate.

Aperture/Sharp Mode

Makes object outline in the picture appear sharper. Ideal for situations where an object merges into the scene with a similar shade of color.

Auto Tracing White Balance (ATW)

Adjusts the white balance automatically in response to varying light conditions.

ATW PRO

Ideal for frequently changing light conditions and applications where the operator needs to see objects as they appear to the eye. Effective operational color range is 2500 to 6000K.

Auto Iris

Automatically adjusts the iris element as the light level changes.

Auto White Balance (AWB)

Automatically memorizes adjusted white balance values.

Backlight Compensation (BLC)

Picture brightness is adjusted automatically depending on lighting conditions. Overcomes the problem of strong backlight which often causes the subject of the picture to be cast into shadow.

C Mount

Type of camera mount which measures 17.5 mm from the lens rear mounting surface to the camera's CCD.

CS Mount

Type of camera mount which measures 12.5 mm from the lens rear mounting surface to the camera's CCD. CS mount lenses can be used with C mount cameras by adding a 5 mm spacer.

DC Servo Auto Iris Lens

Lens that relies on DC power from the camera to control the iris.

Digital Signal Processing (DSP)

Converts the analog signal from a CCD image sensor into a digital signal through an internal A/D converter. The signal is then broken down into luminance and chrominance components for processing, adjustment and feature enhancement enabling many digital features such as backlight compensation.

Duplex

Type of multiplexer allowing simultaneous live monitoring or playback as images are being recorded.

DynaView Technology

A technology used to capture clear images even in extremely high-contrast lighting environments. When using DynaView technology, the camera actually captures the image twice - once at a normal shutter speed and then at a high shutter speed - and creates a composite high-contrast image.

Exwave HAD Technology

Sony technology employing advanced sensor structure within the CCD resulting in improved sensitivity over Super HAD technology.

JPEG

A compression method used in conventional surveillance and monitoring systems that is ideal for capturing high-quality still images.

Motion Detection

A method of detecting motion in an image. Motion detection uses vector information available and inherent in MPEG-4 compression. Motion detection has an advantage over activity detection because it can reduce the number of false alarms caused by noise.

MPEG-4

A compression method that takes into account only the movement in an image when capturing data. MPEG-4 compression is ideal for data that is transferred over networks because of its relatively small data size.

Sensitivity

The amount of light falling on a scene measured in lx.

Simplex

Type of multiplexer which allows the user to choose between live monitoring, recording or playback.

Smear

Vertical streaks above and below a brightly lit object or light source when observed on the monitor. Vertical lines on the screen are caused by the leakage of unwanted light onto the vertical shift register of the CCD.

SuperExwave Technology

Sony camera technology that uses CCDs with advanced photo-diode sensors capable of capturing a great amount of light especially in the near infrared (IR) region of the spectrum. As a result, sensitivity levels have been improved by the following percentages when compared to Exwave HAD technology: Approximately 10% in the visible region, and approximately 50% in the near IR region.

Super HAD Technology

Improves camera sensitivity by optimizing the shape of on-chip micro lenses on the CCD in order to minimize the invalid area between micro lenses of each pixel.

Synchronization

Used in multi-camera installations where automatic switching is employed and allows roll-free switching from camera to camera.

Triple Multiplexing

Video, sync and power transmitted over a single coaxial cable.

GLOSSARY

Turbo AGC

Powerful automatic gain control function. Increases range of video gain compared to conventional AGC resulting in greater sensitivity.

Variable Gamma Curve

Four selectable gamma correction curves that control the brightness of captured images so that they can be displayed accurately (i.e. not too bright and not too dark).

Video Servo Auto Iris Lens

Lens that relies on video input to control the iris opening. When the video level is high, the lens iris closes. When the video level is low, it opens.

NOTES

SONY

For Network Camera Users;

You should keep in mind that the images or audio* you are monitoring through IP network camera may be protected by privacy and other legal rights, and the responsibility for making sure you are complying with applicable laws is yours alone. Access to the images and audio* of IP network camera is protected only by a user name and the password you set up. No further authentication is provided nor should you presume that any other protective filtering is done by the service. Since the service is Internet-based, there is a risk that the image or audio* you are monitoring can be viewed or used by a third-party via the network.

*For equipments that support audio.

Distributed by

©2005 Sony Corporation. All rights reserved.
Reproduction in whole or in part without permission is prohibited.
Features and specifications are subject to change without notice.
All non-metric weights and measures are approximate.
Sony is a registered trademark of Sony Corporation.
SuperExwave, Exwave HAD, DynaView, IPELA, Memory Stick Duo
are trademarks of Sony Corporation.
All other trademarks are property of their respective owners.

Free Manuals Download Website

<http://myh66.com>

<http://usermanuals.us>

<http://www.somanuals.com>

<http://www.4manuals.cc>

<http://www.manual-lib.com>

<http://www.404manual.com>

<http://www.luxmanual.com>

<http://aubethermostatmanual.com>

Golf course search by state

<http://golfingnear.com>

Email search by domain

<http://emailbydomain.com>

Auto manuals search

<http://auto.somanuals.com>

TV manuals search

<http://tv.somanuals.com>