

# ***Custom Integrated AV System***

---

Installation Manual

Owner's Record

The model and serial numbers are located on the rear panel. Record the model and serial numbers in the spaces provided below. Refer to them whenever you call upon your Sony dealer regarding this product.

Model No. \_\_\_\_\_ Serial No. \_\_\_\_\_

***CAV-M1000ES***

## WARNING

To prevent fire or shock hazard, do not expose the unit to rain or moisture.

To avoid electrical shock, do not open the cabinet. Refer servicing to qualified personnel only.

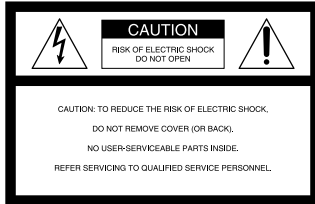

This symbol is intended to alert the user to the presence of uninsulated "dangerous voltage" within the product's enclosure that may be of sufficient magnitude to constitute a risk of electric shock to persons.



This symbol is intended to alert the user to the presence of important operating and maintenance (servicing) instructions in the literature accompanying the appliance.

## WARNING

This equipment has been tested and found to comply with the limits for a Class B digital device, pursuant to Part 15 of the FCC Rules. These limits are designed to provide reasonable protection against harmful interference in a residential installation. This equipment generates, uses, and can radiate radio frequency energy and, if not installed and used in accordance with the instructions, may cause harmful interference to radio communications. However, there is no guarantee that interference will not occur in a particular installation. If this equipment does cause harmful interference to radio or television reception, which can be determined by turning the equipment off and on, the user is encouraged to try to correct the interference by one or more of the following measures:

- Reorient or relocate the receiving antenna.
- Increase the separation between the equipment and receiver.
- Connect the equipment to an outlet on a circuit different from that to which the receiver is connected.
- Consult the dealer or an experienced radio/TV technician for help.

## CAUTION

You are cautioned that any changes or modification not expressly approved in this manual could void your authority to operate this equipment.

If you have any questions about this product, you may call:  
Sony Customer Information Service Center  
1-800-222-7669 or  
<http://www.sony.com/>

The number below is for the FCC related matters only.

## Regulatory Information

### Declaration of Conformity

Trade name: SONY  
Model No.: CAV-M1000ES  
Responsible Party: Sony Electronics Inc.  
Address: 16450 W. Bernardo Dr.  
San Diego, CA 92127 U.S.A.  
Telephone No.: 858-942-2230

This device complies with Part 15 of the FCC Rules. Operation is subject to the following two conditions:

- (1) This device may not cause harmful interference, and (2) this device must accept any interference received, including interference that may cause undesired operation.

### Declaration of Conformity

Trade name: SONY  
Model No.: RM-TP100  
Responsible Party: Sony Electronics Inc.  
Address: 16450 W. Bernardo Dr.  
San Diego, CA 92127 U.S.A.  
Telephone No.: 858-942-2230

This device complies with Part 15 of the FCC Rules. Operation is subject to the following two conditions:

- (1) This device may not cause harmful interference, and (2) this device must accept any interference received, including interference that may cause undesired operation.

## Important Safety Instruction

- 1 Read these instructions.
- 2 Keep these instructions.
- 3 Heed all warnings.
- 4 Follow all instructions.
- 5 Do not use this apparatus near water.
- 6 Clean only with dry cloth.
- 7 Do not block any ventilation openings. Install in accordance with the manufacturer's instructions.
- 8 Do not install near any heat sources such as radiators, heat registers, stoves, or other apparatus (including amplifiers) that produce heat.

- 9 Do not defeat the safety purpose of the polarized or grounding-type plug. A polarized plug has two blades with one wider than the other. A grounding type plug has two blades and a third grounding prong. The wide blade or the third prong are provided for your safety. If the provided plug does not fit into your outlet, consult an electrician for replacement of the obsolete outlet.
- 10 Protect the power cord from being walked on or pinched particularly at plugs, convenience receptacles, and the point where they exit from the apparatus.
- 11 Only use attachments/accessories specified by the manufacturer.
- 12 Use only with the cart, stand, tripod, bracket, or table specified by the manufacturer, or sold with the apparatus. When a cart is used, use caution when moving the cart/apparatus combination to avoid injury from tip-over.
- 13 Unplug this apparatus during lightning storms or when unused for long periods of time.
- 14 Refer all servicing to qualified service personnel. Servicing is required when the apparatus has been damaged in any way, such as power-supply cord or plug is damaged, liquid has been spilled or objects have fallen into the apparatus, the apparatus has been exposed to rain or moisture, does not operate normally, or has been dropped.



## RECYCLING NICKEL METAL HYDRIDE BATTERIES

Nickel Metal Hydride batteries are recyclable.

You can help preserve our environment by returning your used rechargeable batteries to the collection and recycling location nearest you.



For more information regarding recycling of rechargeable batteries, call toll free 1-800-822-8837, or visit <http://www.rbrc.org/>

Caution: Do not handle damaged or leaking Nickel Metal Hydride batteries.

## Welcome!

Thank you for purchasing the Sony Custom Integrated AV System. Before operating the unit, please read this manual thoroughly and retain it for future reference.

# TABLE OF CONTENTS

---

## **Chapter 1** **Getting Started**

- Features 4
  - Unpacking 6
  - Parts and Controls 7
  - Before Customizing the System 14
- 

## **Chapter 2** **Setting up the Main Unit**

- Installing the Main Unit 15
  - Hooking up the Main Unit 17
  - Selecting the Source and the Volume Level of the Main Unit 19
  - Setting up the Remote Code and the Baud Rate – SETUP Mode 20
  - Learning the Remote Code for a Connected Component – LEARN Mode 21
  - Testing Learned Remote Code – CHECK Mode 23
  - Customizing the Main Unit – INSTALLATION Mode 23
- 

## **Chapter 3** **Setting up the Keypad**

- Installing the Keypad 26
  - Hooking up in Each Zone 28
  - Customizing the Keypad 29
  - Testing the Components 30
- 

## **Chapter 4** **Other Information**

- Precautions 31
- Troubleshooting 32
- Error Messages 33
- Specifications 34

## **Chapter 5** **Appendix**

- PRESET and LEARN Mode Code List 35
- Using the RF Remote Control 39
- Using the Keypad 40
- Using the IR Remote Control for the Keypad 41
- Index 42

# Chapter 1

# Getting Started

This chapter provides you with information on the features of the system, its accessories, and the parts and controls of each component.

---

## Features

You can control up to eight audio/video sources in up to six zones with this Custom Integrated AV System. The system consists of:

- a Main Unit
- an RF Remote Control
- Keypad(s) (optional)
- IR Remote Controls for Keypad(s) (optional)

You can enjoy the audio/video source and the output components by using a Keypad in each zone and an RF Remote Control in the main zone. This Custom Integrated AV System allows you to

- Distribute audio/video signals from eight independent sources to six separate zones.
- Control volume adjustment, such as muting, bass and treble adjustments for each of the six zones.
- Control up to eight source components by using an RF Remote Control, a Keypad, or via RS 232C commands.

## Main Unit

- **Zones:** Up to six zones receive up to eight source audio/video signals.
  - **Preamp Outs:** Four fixed outputs for zones 1 to 4, and two variable outputs for zones 5 and 6.
  - **Amplification:** All six zones have built-in stereo audio amplifiers at 30 Watts per channel.
  - **Video outputs** for all six zones.
  - **Keypad connections:** RJ45 connectors for all six zones using CAT5 cables.
- **Sources:** Up to eight audio/video sources can be selected by all six zones.
- **Remote code entry:** Remote code commands can be learned by the Main Unit.
  - on your computer
  - on the Main Unit
- **12 V trigger:** Six zone-specific 12 V status outputs; each 300 mA max, total 1.2 A.
- **RS232C port (Front):** Allows you to connect the Main Unit to your computer to update the settings or firmware.
- **RS232C ports (Rear):** Allow you to connect a Sony DVD Mega Changer (ex. DVP-CX777ES) and a Sony A/V Receiver (ex. STR-DA5000ES) to the Main Unit.

## Keypad

- LCD contrast adjustment.
- Connecting IR IN to an IR emitter enables you to use the IR Remote Control for the additional range.
- RJ45 connectors enable you to use two Keypads in a single zone.

## RF Remote Control

- LCD panel configurable through your computer.
- Controls the audio/video sources in the main zone and the other zones.
- Customize touch panels via an RS232C cross cable connected to your computer.

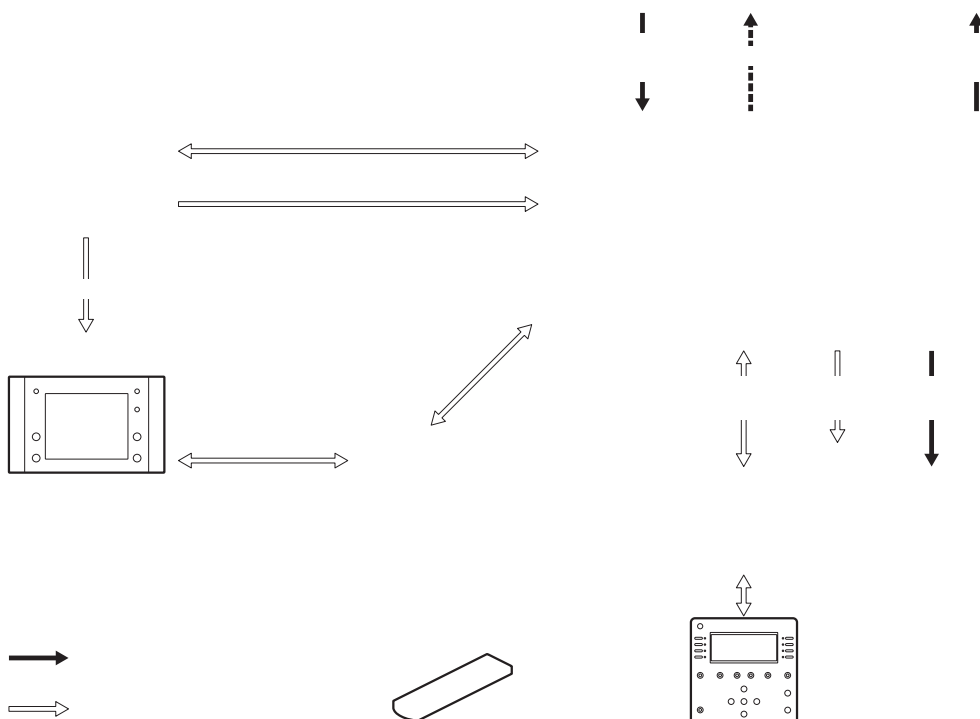

---

# Unpacking

The CAV-M1000ES system includes the following components:

- CAV-M1000ES Main Unit
- RM-TP100 RF Remote Control
- RMB-TP100 Charger cradle for the RF Remote Control
- Ferrite core
- AN-M1000 RF Antenna
- AC power cord
- Plug-in 4-terminal screw-type connector for speaker (6)
- Installation Manual (this manual)

The RMR-K100 system (optional) includes the following:

- RMR-K100 Keypad
- IR Remote Control
- Keypad mounting bracket
- Screws for fixing the Keypad to the Keypad mounting bracket (2)
- Screws for fixing the Keypad mounting bracket to the junction box (4)
- Plug-in 4-terminal screw-type connector for speakers (2)
- R6 (size-AA) battery (2)
- Installation Guide

# Parts and Controls

## Front panel of the Main Unit

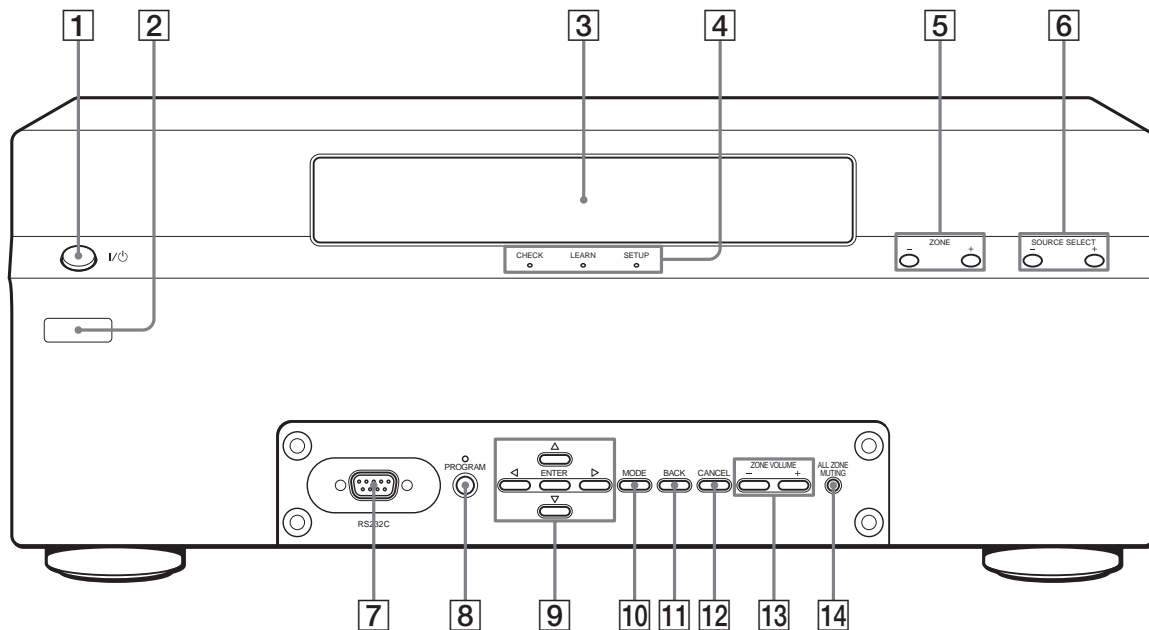

- 1 I/⏻ (POWER) switch**  
Press to turn the power on or off.
- 2 Learning IR window**  
Used to input remote codes into the Main Unit.
- 3 Display window**  
Displays various information.
- 4 Mode indicators**  
Display the current mode. These indicators turn off in the NORMAL mode.
- 5 ZONE +/-**  
Press to select the zone in the NORMAL mode.
- 6 SOURCE SELECT +/-**  
Press to select the source component in the NORMAL mode.
- 7 RS232C connector**  
Used to update the firmware of the Main Unit and to upload/download setup data from a computer using an RS232C cross cable.
- 8 PROGRAM**  
Press to initiate a firmware update.
- 9 Cursor/ENTER**  
Press to select a menu.
- 10 MODE**  
Press repeatedly to select the mode.
- 11 BACK**  
Press to return to the previous layer of the menu.
- 12 CANCEL**  
Press to cancel the present operation and return to the NORMAL mode.
- 13 ZONE VOLUME +/-**  
Press to adjust the volume of the selected zone.
- 14 ALL ZONE MUTING**  
Press to set muting on or off in all zones.

Rear panel of the Main Unit

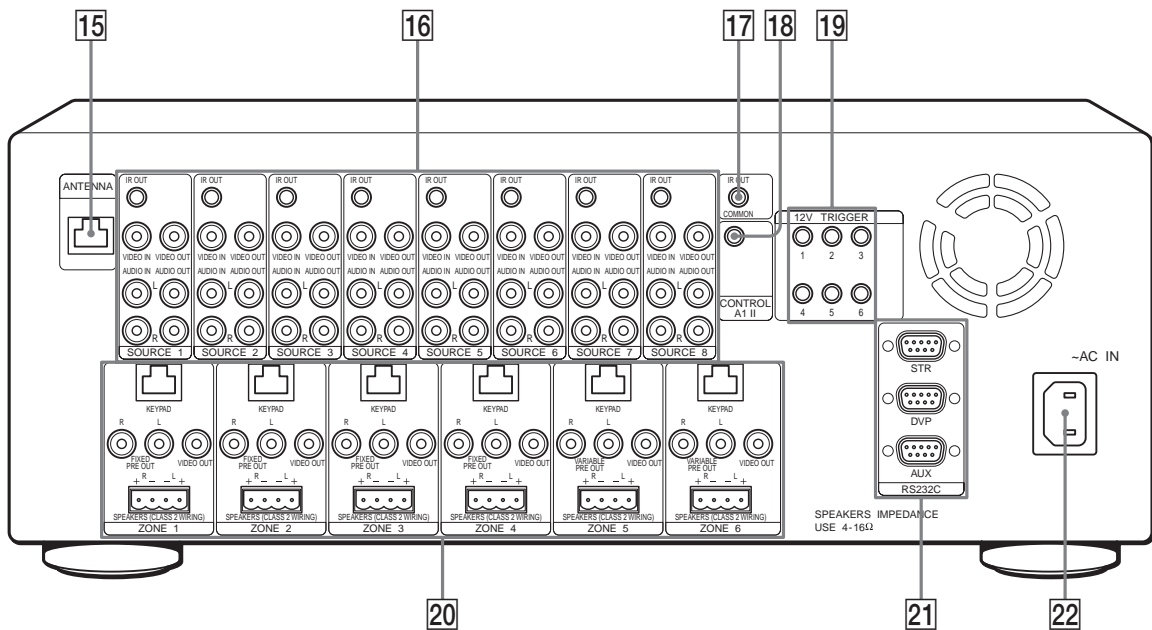

**15 ANTENNA (page 18)**

Hooks up to the RF Antenna using a shielded CAT5 cable, to operate the RF Remote Control.

**16 SOURCE connection jacks**

**a) IR OUT (page 17)**

A 3.5 mm monaural mini jack for the connection of an IR emitter to control the eight source components individually. IR signals received from a zone will be routed to the IR sensor of the source component.

**b) VIDEO IN (page 17)**

An RCA jack for composite video input from a source component.

**c) VIDEO OUT (page 18)**

An RCA jack for connecting a video source to another local component.

**Note**

This is a buffered video connection, and this loop-through is active even when the Main Unit is turned off, as long as the AC power cord is plugged in.

**d) AUDIO IN (page 17)**

RCA jacks for stereo line level audio input from a source component.

**e) AUDIO OUT (page 18)**

RCA jacks for connecting an audio source to another local component.

**Note**

This is a buffered audio connection, and this loop-through is active even when the Main Unit is turned off, as long as the AC power cord is plugged in.

**17 IR OUT COMMON (page 18)**

A 3.5 mm monaural mini jack for the connection of an IR emitter to control any IR-controlled component such as a lighting system or motorized screen.

**18 CONTROL A1II (page 17)**

Hooks up to a Sony CD Mega Changer (ex. CDP-CX455) equipped with a matching jack allowing the Main Unit to control the source component.

**19 12 V TRIGGER (page 18)**

Provide control outputs of +12 V DC that turn devices on and off in sync with the zone to drive voltage sensing relay modules and AC strips.



**20 ZONE connection jacks****a) KEYPAD (page 18)**

An RJ-45 jack for the Keypad interface. Each connector interfaces with the following: power, GND, and data input/output.

**b) VIDEO OUT (page 18)**

An RCA jack that sends a source video signal selected by the zone to the composite video input on a zone display.

**c) FIXED PRE OUT (zones 1 to 4)**

An RCA jack for connecting zone audio output to an external amplifier. For use with applications where either more power is required for a zone. Use an RCA audio cable that is no longer than 2 m.

**d) VARIABLE PRE OUT (zones 5 and 6)**

An RCA jack for connecting zone audio output to an external power amplifier. The volume is attenuated via VOLUME +/- on the Keypad. Use an RCA audio cable that is no longer than 2 m.

**e) SPEAKERS (page 18)**

A plug-in 4-terminal screw-type jack which accepts speaker cords sizes up to 12AWG.

Leave the AC power cord unplugged when you hook up speaker cords.

**21 RS232C (page 17)**

Hook up to other RS232C components, allowing the Main Unit to be controlled by other RS232C components, or to control other components that communicate via RS232C, such as a Sony DVD Mega Changer (ex. DVP-CX777ES) or a Sony A/V Receiver (ex. STR-DA5000ES). Use an RS232C cross cable for the connection.

**22 AC IN (page 18)**

Hooks up the supplied AC power cord to AC IN.

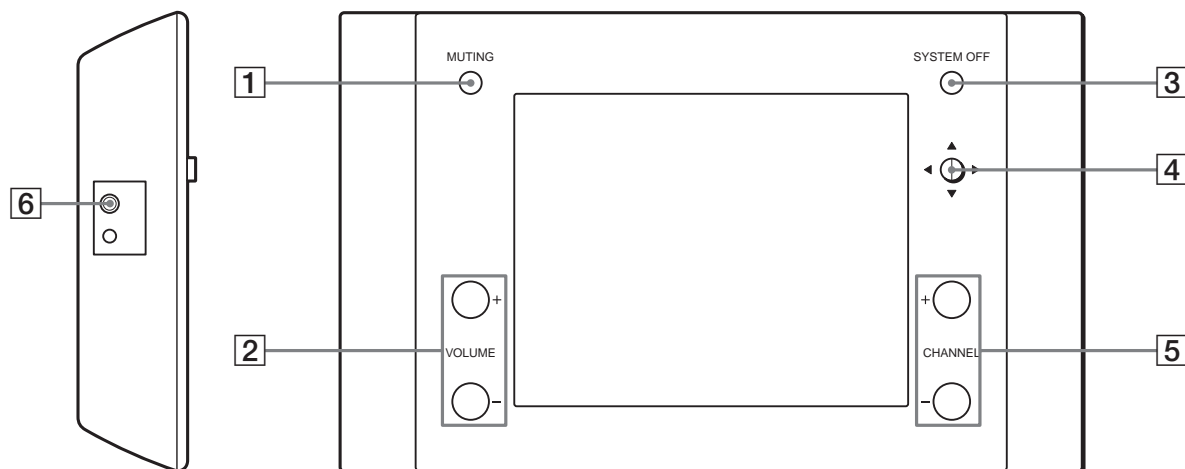
**RF Remote Control****1 MUTING**

Press to mute the audio.

**2 VOLUME +/-**

Press to adjust the volume.

**3 SYSTEM OFF**

Press to shut down the system.

**4 Cursor/ENTER**

Press to control the source.

**5 CHANNEL +/-**

Press to control the source.

**6 RS232C connector**

Hook up a computer using the dedicated RS232C cable.

Front panel of the Keypad

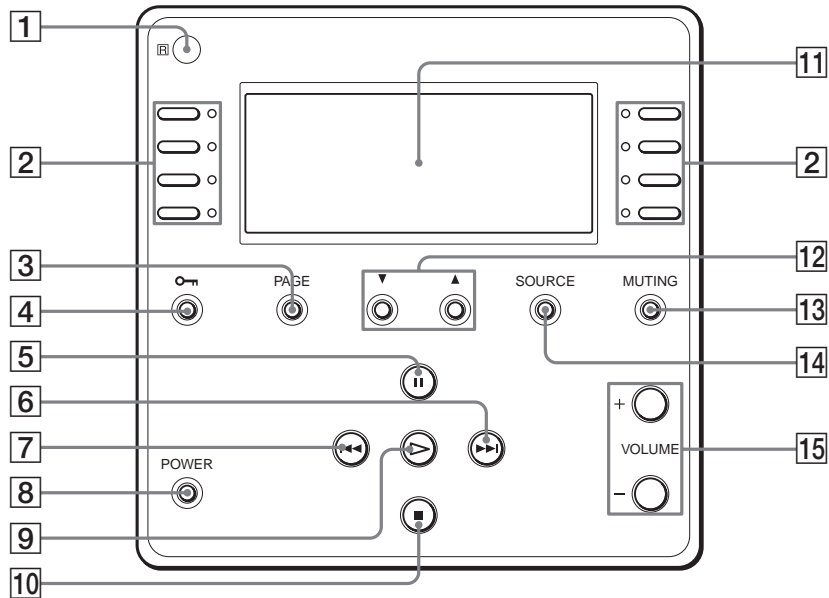

- 1 IR sensor**  
Receives IR signals from the IR Remote Control for the Keypad (supplied) to control both source components and the system.
- 2 SELECT**  
Press to select a menu on the LCD display, such as a source menu, a disc title list, etc.  
The LED next to the SELECT button lights as follows on the source selection:
  - green: selected in the own zone
  - amber: selected and locked in the other zone.
- 3 PAGE**  
Press to return to the previous menu or to view the current status of the disc title list and the preset station list. If there is no list, only a source name will be displayed.
- 4 LOCK**  
Press to lock the selected source.
  - amber: locked
  - off: released
- 5 PAUSE**  
Press to pause the playback.
- 6 FAST FORWARD**  
Press to advance the track/title or to select a preset station.
- 7 REVERSE**  
Press to go reverse the track/title or to select a preset station.
- 8 POWER switch**  
Press to turn the power of the Keypad on or off.
- 9 PLAY**  
Press to operate the selected source.
- 10 STOP**  
Press to stop playback.
- 11 Display window**  
Displays the selected source, the zone volume level, the zone and the system status, and other system status information.
- 12 SCROLL UP/DOWN**  
Press to scroll the LCD menu.
- 13 MUTING**  
Press to mute the speaker output in the zone.
- 14 SOURCE**  
Press to return to the source components list screen.
- 15 VOLUME +/-**  
Press to adjust the volume in a zone.

## Rear panel of the Keypad

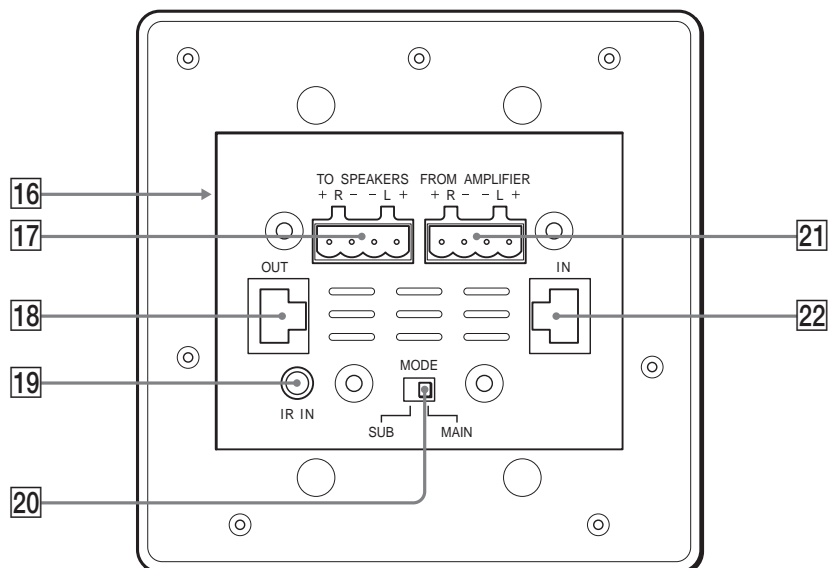

### 16 Brightness adjustment hole (page 29)

The hole is located on the side.

Use a flathead screwdriver to adjust the brightness of the background of the display window.

### 17 TO SPEAKERS (page 28)

Connects speaker cords to the speakers in a zone.

### 18 OUT (page 28)

Connects a CAT5 straight cable to the IN jack of the subsidiary Keypad when used in a single room.

### 19 IR IN (page 28)

Connects an optional IR emitter so you can operate the IR Remote Control for the Keypad by pointing it at the IR sensor of the connected IR emitter.

### 20 MODE switch (page 28)

When using two Keypads in a single room, set this switch to SUB on the subsidiary Keypad.

### 21 FROM AMPLIFIER (page 28)

Connect speaker cords to the Main Unit.

### 22 IN (page 28)

Connects a CAT5 cable from the Main Unit to the main Keypad.

## IR Remote Control for Keypads

Buttons marked in gray are used to control the source components.

**1 SLEEP**

Press to activate the sleep function that turns off the Keypad automatically after the specified duration. The time changes as shown below.

2:00 → 1:30 → 1:00 → 0:30 → OFF

**2 DIMMER**

Press repeatedly to change the brightness of the LCD backlight.

**3 Numeral**

Press to select a number, representing, for example, a desired track of the source.

**4 SELECT**

Press to select a menu on the display on the LCD, such as a source menu, a disc title list, etc.

**5 LOCK**

Press to lock the selected source.

**6 PAGE**

Press to return to the previous menu or to view the current status of the disc title list or the preset station list. If there is no list, only a source name will be displayed.

**7 DOWN**

Press to scroll the LCD menu down.

**8 ◀▶/▶▶**

Press to locate a specific track of the source or to select a preset station.

**9 || (PAUSE)**

Press to pause the playback of the source.

**10 ▶ (PLAY)**

Press to operate the selected source.

**11 TOP MENU/GUIDE**

Press to display the top menu while using a source component such as a DVD player.

**12 CURSOR/ENTER**

Press to select a menu while using a source component such as a DVD player.

**13 DISPLAY**

Press to display on-screen messages from equipment such as a DVD player.

You cannot control commands, such as PROGRAM, SHUFFLE, REPEAT and A-B REPEAT of the DVD Mega Changer that appear on the display when you press DISPLAY.

**14 RETURN/EXIT**

Press to return to the previous menu screen (level) or to quit the menu function while using a source component such as a DVD player.

**15 TV VOL +/-**

Press to adjust the Sony TV volume.

**16 TV CH +/-**

Press to change the Sony TV channel.

**17 I/⏻ switch**

Press to turn the Keypad on/off.

**18 TV I/⏻ switch**

Press to turn the Sony TV on/off.

**19 ENTER**

Press to confirm the selection.

**20 DISC**

Press to select a disc of a DVD/CD Mega Changer.

**21 SOURCE**

Press to return to the source components list screen.

**22 UP**

Press to scroll the LCD menu up.

**23 ◀▶/▶▶**

Press to locate a portion you want to play within a track of the source.

**24 ■ (STOP)**

Press to stop the current playback.

**25 MENU**

Press to display a menu while using a source component such as a DVD player.

**26 MUTING**

Press to mute the speaker output in a zone.

**27 VOLUME +/-**

Press to adjust the volume in a zone.

**28 F1**

A button reserved for source components.

**29 F2**

A button reserved for source components.

**30 FOLDER**

Press to move to the FOLDER screen while using a DVD player.

**31 TV/VIDEO**

Press to switch signals between TV input and Video input of the Sony TV monitor.

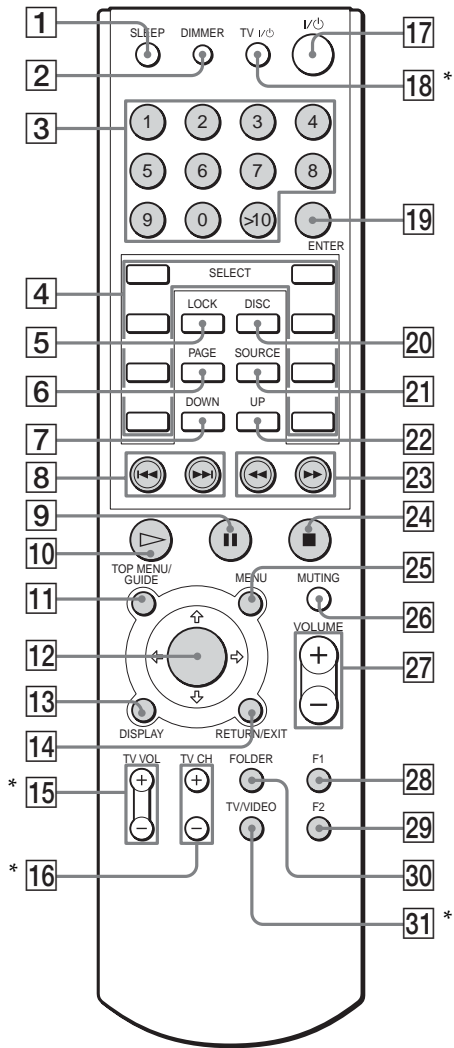

\* Only a Sony TV monitor can be controlled with these buttons.

# Before Customizing the System

Be sure to read the following procedure thoroughly before you actually make any settings.

## Overview

The following chart gives an overview of how to set up the Main Unit system.

### Setting up the Main Unit

- Install the Main Unit. (page 15)
- Connect components, such as source components and output components, to the Main Unit. (page 17)
- Make other connections.

### Setting up a Keypad

- Install the Keypad into a junction box. (page 26)
- Connect the Main Unit and the Keypad. (pages 17, 18)

### Customizing the Main Unit

- Customize the Main Unit on your computer. (page 20)
- Customize the Main Unit. (page 21)

### Testing the components (page 30)

### Setting up the RF Remote Control

- Customize the RF Remote Control on your computer.

For detailed information on the RF Remote Control, please consult your nearest Sony dealer.

## Planning the system

Before setting up the system, plan the system configuration.

- 1** Decide the source components to be connected to each SOURCE connection of the Main Unit.
- 2** Decide the allocation of the components to be used in each zone.

SOURCE No.	Source component
SOURCE 1	ex. CD Player
SOURCE 1	
SOURCE 2	
SOURCE 3	
SOURCE 4	
SOURCE 5	
SOURCE 6	
SOURCE 7	
SOURCE 8	

ZONE No.	Room No.
ZONE 1	ex. Kitchen
ZONE 1	
ZONE 2	
ZONE 3	
ZONE 4	
ZONE 5	
ZONE 6	

## Chapter 2

# Setting up the Main Unit

This chapter provides you with information on the Main Unit regarding installation, hookups and settings.

## Installing the Main Unit

When you mount the Main Unit, note the following:

- Place the Main Unit on a flat and level surface.
- When installing it in a cabinet, make sure the back of the cabinet is open to allow adequate ventilation, prevent heat buildup, and prolong the life of the unit.
- Place a board under the Main Unit if it is located on a carpet to allow adequate ventilation on the bottom.
- Make sure the weight is equally distributed on each of its four feet.
- Do not place anything on the top of the Main Unit that might block the ventilation holes and cause malfunction.
- Do not place anything on the front or rear panel that might damage the Main Unit's control buttons and connectors.
- Use caution when placing the unit or speakers on surfaces that have been specially treated (with wax, oil, polish, etc.) as staining or discoloration of the surface may result.

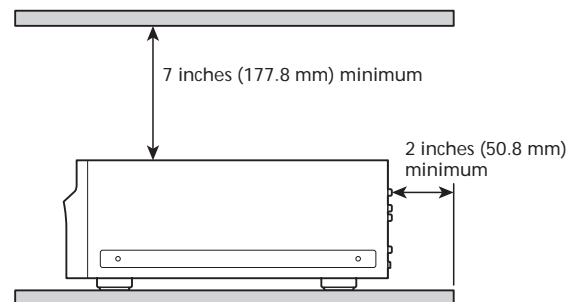

Leave at least 3 inches (76.2 mm) on each side for ventilation.

## Installing the Main Unit

If you install the Main Unit in a closed cabinet, attach two small boxer fans in the cabinet to provide continuous ventilation.

**Boxer fan (55 CFM)  
centered 7 inches  
(177.8 mm) on top of  
the Main Unit**

**Boxer fan (55 CFM)  
centered 2 inches  
(50.8 mm) behind the  
Main Unit**

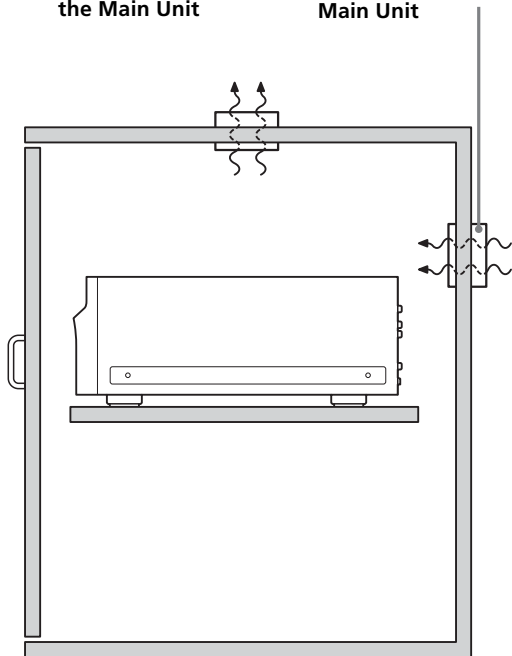

Setting up the Main Unit

### Note

Attach boxer fans also if you connect low-impedance speakers (less than 8 ohms nominal).

## Installing the RF Antenna

Mount the RF Antenna in an appropriate place in the room where the RF Remote Control is to be used.

For details on how to make the connection, refer to "RF Antenna hookup" on page 18.

### Horizontal position

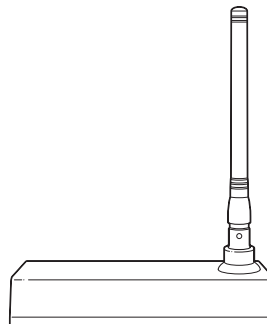

### Vertical position





# Hooking up the Main Unit

Before hooking up the Main Unit, be sure the power cord is unplugged. Refer to the figures below for the connections.

## Source component hookups

### AUDIO IN jack (A)

Hook up the audio output of each source component and the AUDIO IN jack of each SOURCE connection jack of the Main Unit.  
Use RCA audio cables.

### VIDEO IN jack (B)

Hook up the video output of each source component and the VIDEO IN jack of each SOURCE connection jack of the Main Unit.  
Use an RCA video cable.

### RS232C connector (C)

Hook up any RS232C equipped source component and the RS232C connector of the Main Unit.  
Use an RS232C cross cable.  
You can control the connected RS232C components (ex. DVP-CX777ES, STR-DA5000ES) from the Main Unit by sending commands.

### CONTROL A1II jack (D)

Hook up each CONTROL A1II jack of the source equipment such as CDP-CX455 and the Main Unit.  
Use a CONTROL A1II cable. However, you cannot hook up another component to CDP-CX455 with a CONTROL A1II cable.  
You can control the connected source component from the Main Unit.

### IR OUT jack (E)

Plug the IR emitter into the IR OUT jack of each SOURCE connection jack of the Main Unit. Be careful to match the source audio and video connection number on the Main Unit to the IR emitter connector number.  
The IR control signal will be routed to the correct source component. Find the IR sensor window on the source component and attach the emitter to the component sensor.

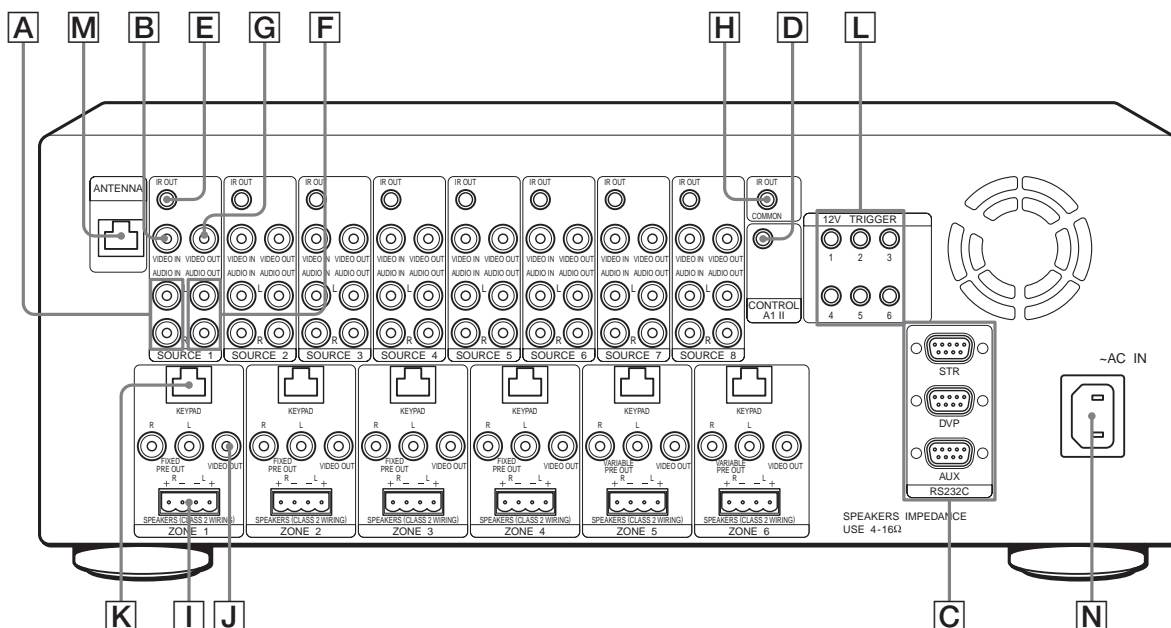

## Hooking up the Main Unit

### Output component hookups

#### AUDIO OUT jack (F)

Hook up the AUDIO OUT jack of each SOURCE connection jack of the Main Unit and each audio input of the external A/V receiver.

Use RCA audio cables.

#### VIDEO OUT jack (G)

Hook up the VIDEO OUT jack of each SOURCE connection jack of the Main Unit and each video input of the external A/V receiver.

Use RCA video cables.

#### IR OUT COMMON jack (H)

Plug the IR emitter into the IR OUT COMMON jack of the Main Unit.

The IR control signal will be routed to the output component (an auxiliary device that are not source specific). Find the IR sensor window on the output component and attach the IR emitter to the component sensor.

### Zone related cables hookups

#### SPEAKERS jack (I)

Hook up the SPEAKERS jack of each ZONE connection jack of the Main Unit and the FROM AMPLIFIER jack of each Keypad.

Use speaker cords terminated with plug-in 4-terminal screw-type connectors.

Leave the AC power cord unplugged when you hook up speaker cords.

#### VIDEO OUT jack (J)

Hook up the VIDEO OUT jack of each ZONE connection jack of the Main Unit and the video input of the TV monitor in each zone.

Use an RCA video cable.

#### KEYPAD jack (K)

Hook up the KEYPAD jack of each ZONE connection jack of the Main Unit and the IN jack of each Keypad.

Use a CAT5 cable.

#### 12 V TRIGGER jack (L)

Hook up the 12 V TRIGGER jack of the Main Unit and the device used to drive a voltage sensing relay module and an AC strip.

Use a 3.5 mm monaural mini plug cord.

### RF Antenna hookup (M)

Hook up the ANTENNA jack of the Main Unit and the jack of the RF Antenna.

Use a shielded CAT5 cable less than 50 feet in length.



### AC power cord hookup (N)

Connect the supplied AC power cord to the AC IN jack.

# Selecting the Source and the Volume Level of the Main Unit

## Selecting the source for each zone

In the NORMAL mode, you can select a source component for each zone. The status information for each zone appears on the display window.

- 1 Select a zone by pressing the ZONE + or ZONE – button.
- 2 Select a source component by pressing the SOURCE SELECT + or SOURCE SELECT – button.  
The source component is confirmed one second after you release the SOURCE SELECT button.

Example 1: When a source component connected to the SOURCE 1 Out/In plugs is selected in ZONE 1.

Z	O	N	E	1	:	S	O	U	R	C	E	1			1
ZONE					:	SOURCE Title						SOURCE No			

Example 2: When you connect a source component whose title has changed from SOURCE 1 to DVD in the PC SETUP mode.

Z	O	N	E	1	:	S	O	U	R	C	E					1
↓																
Z	O	N	E	1	:	D	V	D								1

### Tip

Even when you connect several DVD players to the Main Unit, you can distinguish each of them by the source number displayed on the far right side in the display window.

## Adjusting the volume in each zone

- 1 Press ZONE+ or ZONE – repeatedly to select a zone.
- 2 Press ZONE VOLUME+ or VOLUME – to display the current volume level.

The display window changes as shown below.

→	VOLUME	MIN
	VOLUME	1
	⋮	
	VOLUME	73
←	VOLUME	MAX

### Note

The volume level displayed in the display window varies depending on the volume limits you have set as described in "Setting volume limits" on page 29.

- 3 Press ZONE VOLUME+ or VOLUME – repeatedly to adjust the volume to the desired level.

The display window returns to the NORMAL mode in a few seconds after you have finished.

### Note

In a zone where SOURCE INPUT OFFSET is ON, the actual volume level is lower than the displayed volume level (page 24).

## Turning ALL ZONE MUTING on or off

- 1 Press ALL ZONE MUTING on the Main Unit.  
"ALL ZONE MUTING" appears in the display window, then the display window returns to the previous display.
- 2 To turn ALL ZONE MUTING off, press ALL ZONE MUTING again.  
"MUTING OFF" appears for a few seconds, then the display window returns to the previous display.

# Setting up the Remote Code and the Baud Rate

## - SETUP Mode

### Note

A Keypad connected to the Main Unit automatically turns off in the SETUP mode.

### Setting the baud rate - BAUD RATE SET

You can adjust the baud rate between the Main Unit and an FM/AM Receiver (STR) or DVD Mega Changer connected via an RS232C connection.

- 1 Press MODE repeatedly until "<<SETUP>>←→" appears in the display window, then press ENTER. "WHICH MENU?" appears for a few seconds.
- 2 Press the ↑ cursor or ↓ cursor to select "BAUD RATE SET".  
Each time you press the ↑ cursor or ↓ cursor, the display window changes as follows:  
"PC SETUP ↑↓" ↔ "BAUD RATE SET ↑↓"
- 3 Press ENTER.  
"WHICH PORT?" appears for a few seconds.
- 4 Press the ↑ cursor or ↓ cursor to select a port.  
Each time you press the ↑ cursor or ↓ cursor, the display window changes cyclically as shown below.

WHICH PORT? (Appears for a few seconds)

	↑		
→	FRONT	RS232C	↑↓
→	STR	RS232C	↑↓
→	DVP	RS232C	↑↓
→	AUX	RS232C	↑↓

- 5 Press ENTER.  
The baud rate setting display appears.
- 6 Press the ↑ cursor or ↓ cursor to select the desired baud rate.  
Each time you press the ↑ cursor or ↓ cursor, the display window changes cyclically as shown below.

→	9600 bps	↑↓
→	14400 bps	↑↓
→	19200 bps	↑↓
→	38400 bps	↑↓
→	57600 bps	↑↓
→	115200 bps	↑↓
→	128000 bps	↑↓

- 7 Press ENTER when you have finished.  
The display window returns to the NORMAL mode.

### Setting up the Main Unit connected to a computer - PC SETUP

You can transfer setting data to the Main Unit and customize it using an RS232C connection to your computer.

The items that should be customized on your computer are the following.

- The information needed to specify the source component, output component, and remote code settings
- 12V Trigger

### Note

Do not connect speakers and a TV to the Main Unit while in the PC SETUP mode.

- 1 Connect the RS232C connector on the Main Unit to your computer with an RS232C cross cable.
- 2 Press MODE repeatedly until "<<SETUP>>←→" appears in the display window, then press ENTER. "WHICH MENU?" appears for a few seconds.
- 3 Select "PC SETUP" by pressing the ↑ cursor or ↓ cursor.  
Each time you press the ↑ cursor or ↓ cursor, the display window changes as follows:  
"PC SETUP ↑↓" ↔ "BAUD RATE SET ↑↓"
- 4 Press ENTER.  
"READY!" appears in the display window. You are now ready to transfer data between the Main Unit and your computer.
- 5 Set up the Main Unit using the CAV-M1000ES Editor software .  
For details, see the Operating Instructions of the CAV-M1000ES Editor software.
- 6 "PLEASE WAIT..." appears while data is being transferred.  
When the data has been transferred successfully, "COMPLETED!" appears in the display window. If the data transfer is unsuccessful, "FAILED!" appears until pressing "ENTER", then changes to "READY!"  
Go back to step 5 to transfer the data again.
- 7 Press ENTER when you have finished.

# Learning the Remote Code for a Connected Component – LEARN Mode

You can enter any remote codes, even if the remote code that you want to enter is not preset in the SETUP mode.

## Learning the remote code - CODE LEARNING

- 1 Press **MODE** repeatedly until “<<LEARN>>←→” appears in the display window, then press **ENTER**. “WHICH MENU?” appears for a few seconds.
- 2 Press the **↑** cursor or **↓** cursor repeatedly to select “CODE LEARNING”, then press **ENTER**. “CONNECT TO?” appears for a few seconds.
- 3 Press the **↑** cursor or **↓** cursor repeatedly to select the desired component.  
Each time you press the **↑** cursor or **↓** cursor, the display window changes cyclically as shown below.

CONNECT TO? (Appears for a few seconds)

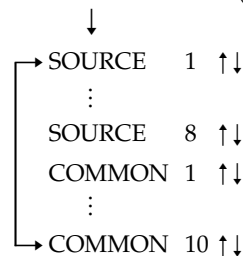

### Note

SOURCE or COMMON components, which have been set to learn command codes on PC SETUP, appear with an exclamation mark (!) at the left side of the display window.

- 4 Press **ENTER**.  
“INPUT IR CODE” appears for a few seconds, then display window changes to “CODE ID #001 **↑** **↓**”.
- Note**  
Refer to “PRESET and LEARN Mode Code List” on page 35 to see the code ID number corresponding to each IR command. For example, if “CODE ID #001” is displayed, press Num1 of the remote control of the source component to learn it into the Main Unit.

- 5 While the code ID number is displayed in the display window, press the corresponding button on the remote control of the component while pointing it toward the learning IR window of the Main Unit.

Make sure the distance between the remote control and the IR window is within 10 cm.

When your entries are confirmed, “COMPLETED!” appears for a few seconds, then the display window moves to the next remote code entry.

If your entries are not confirmed, “LEARN FAILED!” appears for a few seconds, then the failed code ID number appears.

### Tips

- When you want to skip the code ID number, press the cursor **↓**.
- When you want to re-enter the code ID, press the cursor **↑**.

### Notes

- When the remote code has been successfully learned, a “\*” will appear next to the remote code name.
- You can enter up to 29 remote codes for each source component, and up to 50 remote codes for each common component into the Main Unit.
- You must complete step 5 within one minute after the remote code name is displayed in the display window; otherwise, your entry will not be learned and “LEARN FAILED!” appears.

- 6 Repeat step 5 to enter other remote codes.

- 7 Press **ENTER** when you have finished.

“SETTING NOW...” appears for a few seconds. Then, the display window returns to the NORMAL mode.

### Notes

- Even if you quit the LEARN mode in the midst of making the settings, the remote codes that have already been learned will be stored.
- Some remote codes cannot be learned. In this case, “MEMORY FULL” appears, then the display window returns to the previous remote code entry. The remote codes that have already been learned will be stored.

You can add new remote codes using EXPAND CODE.

## Adding a new remote key - EXPAND CODE

**1 Press MODE repeatedly until "<<LEARN>>←→" appears in the display window, then press ENTER.**  
"WHICH MENU?" appears for a few seconds.

**2 Press the ↑ cursor or ↓ cursor to select "EXPAND CODE", then press ENTER.**  
"CONNECT TO?" appears for a few seconds.

**3 Press the ↑ cursor or ↓ cursor repeatedly to select the desired component.**  
Each time you press the ↑ cursor or ↓ cursor, the display window changes cyclically as shown below.

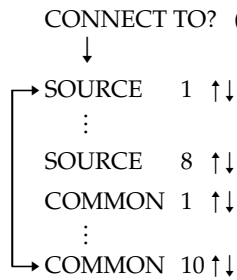

**Note**

A component that has not been connected to the Main Unit is grayed out in the display window. You cannot select it.

**4 Press ENTER.**  
"INPUT IR CODE" appears for a few seconds, then the display window changes to "CODE ID #81↑↓" when you select SOURCE in step 3, and changes to "CODE ID #110↑↓" when you select COMMON.

**5 While the code ID number is displayed in the display window, press the corresponding button on the remote control of the component while pointing it toward the learning IR window of the Main Unit.**

When your entries are confirmed, "COMPLETED!" appears for a few seconds, then the display window moves to the next remote code entry.

If your entries are not confirmed, "LEARN FAILED!" appears for a few seconds, then the failed code ID number appears.

**Tips**

- When you want to skip the code ID number, press the ↓ cursor.
- When you want to re-enter the code ID, press the ↑ cursor.

**Notes**

- When the remote code is successfully learned, a "\*" will appear next to the remote code name.
- You can add up to 31 additional remote codes for each source component, and up to 10 for each common components.
- You must complete step 5 within one minute after the remote code name is displayed in the display window; otherwise, your entry will not be learned and "LEARN FAILED!" appears.

**6 Repeat step 5 to enter other remote codes.**

**7 Press ENTER when you have finished.**  
"SETTING NOW..." appears for a few seconds. The display window returns to the NORMAL mode.

**Notes**

- Even if you quit the LEARN mode in the midst of making the settings, the remote codes that have already been learned will be stored.
- Some remote codes cannot be learned. In this case, "MEMORY FULL" appears, then the display window returns to the previous remote code entry. The remote codes that have previously been learned will be stored.

## Testing Learned Remote Code – CHECK Mode

You can check to see if the remote code of the source component have been successfully learned by the Main Unit.

- 1 Press SOURCE SELECT +/- to select the source component that you want to check.**
- 2 Press MODE repeatedly until "<<CHECK>>" appears in the display window, then press ENTER.**  
"SET COMMAND" appears for a few seconds, then some of the learned remote codes appear in the display window.
- 3 Press the ↑ cursor or ↓ cursor repeatedly to select the remote code that you want to check (ex. play, stop).**
- 4 Press ENTER.**  
The selected remote command will be performed.

## Customizing the Main Unit – INSTALLATION Mode

### Viewing disc information – DISC SEARCH

By connecting a Sony DVD Mega Changer to an RS232C jack, or a Sony CD Mega Changer to CONTROL A1II, you can view disc information, such as a disc title.

- 1 Turn off the power.**
- 2 Press and hold MODE and the ← cursor simultaneously, and then turn on the power.**  
"DISC SEARCH" appears in the display window for a few seconds, then, "DVD MEGA" appears.
- 3 Press the ↑ cursor or ↓ cursor to select "DVD MEGA" or "CD MEGA".**
- 4 Press ENTER.**  
"SEARCHING NOW..." appears and flashes while the Main Unit is searching for the disc information.  
"COMPLETED!" appears after the information has been received, and a DVD Mega Changer or a CD Mega Changer turns off automatically.  
"FAILED!" appears when information is not found or cannot be read.
- 5 Press ENTER when you have finished.**  
The display returns to the NORMAL mode.

**Adjusting the source input offset  
– SOURCE INPUT OFFSET**

You can keep the volume balance among source components by taking an average of the output level from each source component.

- 1 Turn off the power.**
- 2 Press and hold ZONE + and ALL ZONE MUTING simultaneously, and then turn on the power.**  
“SOURCE OFFSET” appears in the display window for a few seconds.
- 3 Press the ↑ cursor or ↓ cursor repeatedly to select a source number.**

Each time you press the ↑ cursor or ↓ cursor, the display window changes cyclically as shown below.

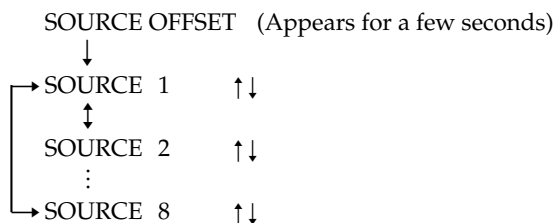

- 4 Press ENTER.**  
The display window displays the OFFSET settings.
- 5 Press the ↑ cursor or ↓ cursor to adjust the offset.**  
Each time you press the ↑ cursor or ↓ cursor, the display window changes cyclically as shown below.

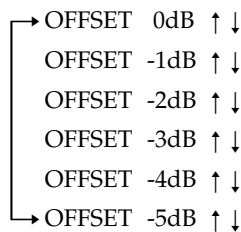

- 6 Press ENTER when you want to adjust the offset for other source components.**  
The step goes back to step 3.
- 7 Press CANCEL when you have finished.**  
The display window returns to the NORMAL mode.

**Note**

In a zone where SOURCE INPUT OFFSET is ON, the actual volume level is lower than the displayed volume level.

**Locking the settings – SETUP LOCK**

You can lock in the settings under which have been entered into the Main Unit.

- 1 Turn off the power.**
- 2 Press and hold SOURCE SELECT + and BACK simultaneously, and then turn on the power.**  
“SETUP LOCK” appears for a few seconds, then the display window displays the SETUP LOCK window.
- 3 Press the ↑ cursor or ↓ cursor to turn SETUP LOCK on or off.**

The display window changes as follows:  
SETUP LOCK (Appears for a few seconds)

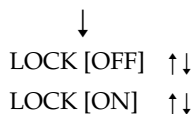

- 4 Press ENTER when you have finished.**  
The display window returns to the NORMAL mode.

**Notes**

- The following are the preferences that can be locked in in the SETUP LOCK mode.
  - All settings in the LEARN mode.
  - All settings in the SETUP mode.
  - Settings for the Disc Search.
  - The adjustment of SOURCE OFFSET.
  - All Clear.
- When you select settings that cannot be changed, “LOCKED!” appears for a few seconds, then the display window returns to the NORMAL mode.



## Viewing the version information – CIS VERSION

CIS VERSION provides you the version information of the Main Unit and other external components, such as an FM/AM Receiver (STR), a DVD Mega Changer, an RF Remote Control, or the Keypad.

### 1 Turn off the power.

#### 1 Press and hold ZONE – and CANCEL simultaneously, and then turn on the power.

“CIS VERSION” appears in the display window for a few seconds.

#### 2 Press the ↑ cursor or ↓ cursor to view the version information.

Each time you press the button, the display window changes as shown below.

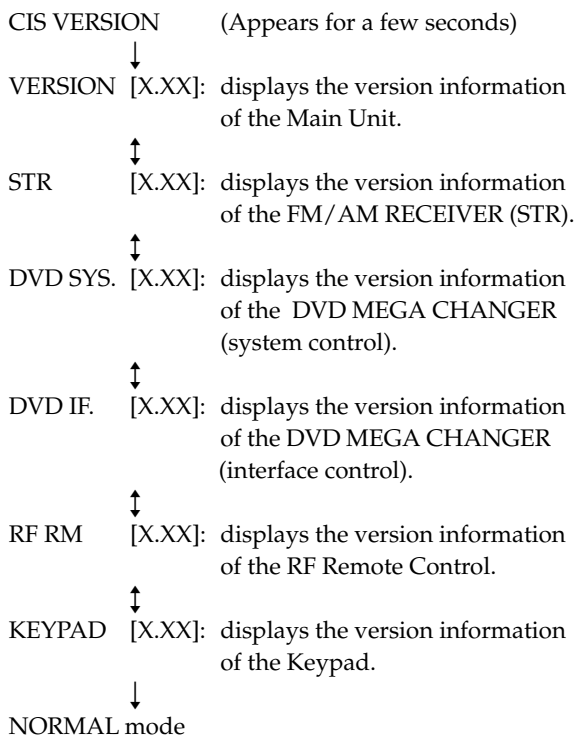

## Initializing all the settings – ALL CLEAR

Note that all memory data will be deleted when you initiate an ALL CLEAR setting.

### 1 Turn off the power.

#### 2 Press and hold SOURCE SELECT + and CANCEL simultaneously, and then turn on the power.

“MEMORY CLEARING” appears in the display window during the initialization.

When the initialization is completed, “MEMORY CLEARED!” appears for four seconds, then the display window returns to the NORMAL mode.

#### 3 Power will be turned off automatically after the display window returns to the NORMAL mode.

### Notes

- Any command keys other than POWER are not enabled during the initialization of the Main Unit. If pressed, they are not recognized.
- If you turn off the power before the initialization is completed, the Main Unit will start initializing settings again when you turn on the power the next time.

# Chapter 3

## Setting up the Keypad

This chapter provides you with information regarding installation, hookup and settings for the optional Keypad.

### Installing the Keypad

A Keypad must be installed in a junction box (not supplied). Follow the procedures below to mount a Keypad mounting bracket and a Keypad on the wall.

#### Installing the Keypad

- 1 Place the Keypad mounting bracket over a junction box which has already been installed on the wall with the mounting lips facing out.**
- 2 Attach the Keypad mounting bracket to the junction box with the supplied screws at the four points as shown below.**

Proceed to the steps in “Zone related cables hookups” on page 18 before mounting the Keypad.

#### Note

The Keypad mounting bracket may not fit easily over some junction boxes. In this case, loosen the screws and move the Keypad mounting bracket left to right to center on the junction box.



- 3** Insert the top of the Keypad onto the mounting bracket first, in the direction of the arrow **1** until it clicks, then push the bottom of the Keypad onto the bracket in the direction of the arrow **2**.

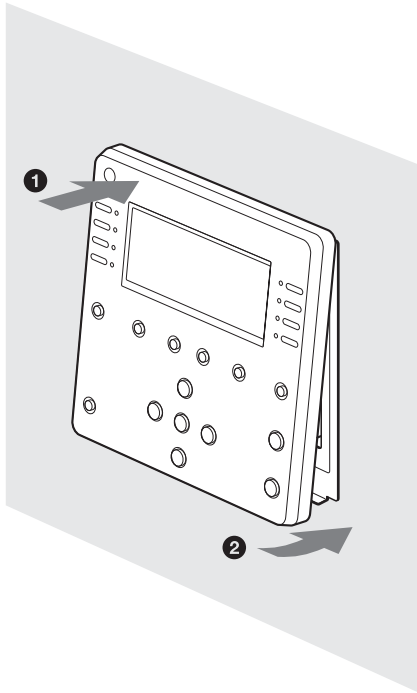

- 4** Fix and tighten the Keypad mounting screws as shown below.

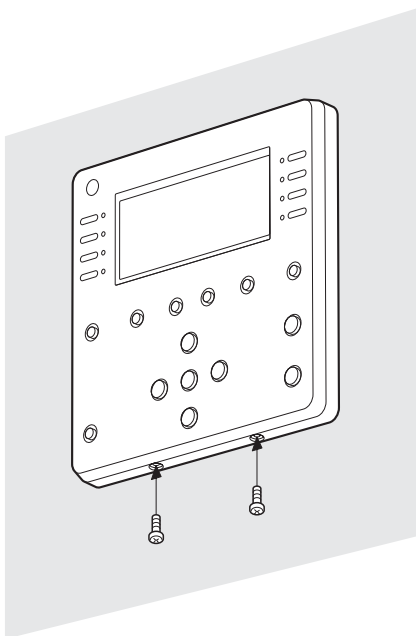

- 5** When you have finished mounting the Keypad, check that it operates properly.

### Removing the Keypad

- 1** Remove the screws that hold the Keypad and the Keypad mounting bracket.
- 2** Press and hold the edge of the upper-side of the Keypad tightly. Pull the lower part of the Keypad away from the Keypad mounting bracket first, then pull the upper part of the Keypad out slightly, lifting it in the direction of the arrow, as shown below.

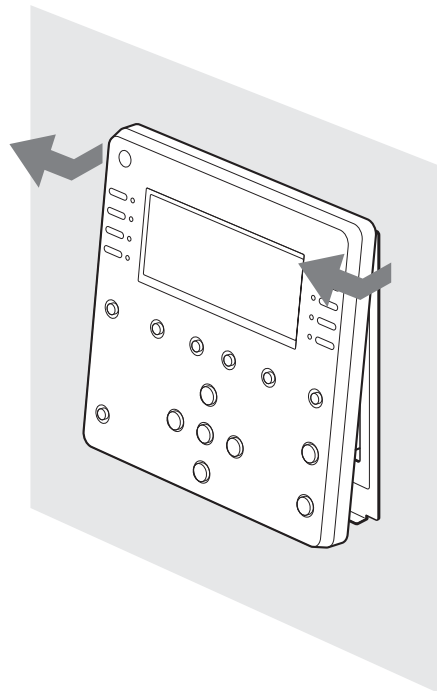

#### Note

You may need some extra effort to remove the Keypad from the wall since there are various kinds of junction boxes, and the installation environment of the Keypad differs.

# Hooking up in Each Zone

You must install at least one Keypad and a pair of speakers in each zone. In the zones where both audio and video will be installed, you must install at least one TV monitor.

Requirements for these hookups are as follows.

- A CAT5 cable has been installed for each zone's Keypad.
- Two pairs of 12 to 18 AWG speaker cords for each pair of speakers.
- An RCA video cable for a TV monitor from each zone to the Main Unit location.

## TV monitor hookup

Hook up the video input of the TV monitor in each zone and the VIDEO OUT of each ZONE connection jack of the Main Unit.

Use an RCA video cable.

## Speakers hookup

- 1 Hook up the speaker cords from the SPEAKERS jack of each ZONE connection jack of the Main Unit to the FROM AMPLIFIER jack of the Keypad in each zone.**
- 2 Hook up the speaker cords from the TO SPEAKERS jack of the Keypad to the speaker terminals in each zone.**

### Notes

- Use speakers which have a combined impedance of between 4 and 16 Ohms loaded.
- Twist the stripped ends of the speaker cords about 2/3 inch (10 mm). Be sure to match the speaker cord to the appropriate terminal on the components: + to + and - to -. If the cords are reversed, the sound will be distorted and will lack bass.
- 14 AWG speaker cords are recommended for speaker runs up to 150 feet (45 m). The 4-terminal connectors accept speaker cord sizes up to 12 AWG, maximum.
- If you use speakers with a low maximum input rating, adjust the volume carefully to avoid excessive output on the speakers.
- All speaker hook-up should be done with the Main Unit in AC unplugged condition.
- After the lead ends are inserted and the screws are tightened down, be sure there are no free strands that could cause shorting.
- Muting is controlled by using a switch inside the Keypad. Hook up speakers via a Keypad to let the muting function available.

## CAT5 cable hookup

- 1 Set the MODE switch to MAIN on the rear panel of the Keypad.**
- 2 Hook up the CAT5 cable from the KEYPAD jack of each ZONE connection jack of the Main Unit to the IN jack of the Keypad in each zone.**

### To install two Keypads in the same zone

You can install two Keypads in a single room.

- 1 Set the MODE switch to SUB on the rear panel of the subsidiary Keypad.**
- 2 Hook up the CAT5 straight cable from the OUT jack of the Keypad for which the MODE switch is set to MAIN, to the IN jack of the subsidiary Keypad.**

### Notes

- Note that the length of CAT5 cables for each connection is limited. See the figure below for the maximum length of CAT5 cables.

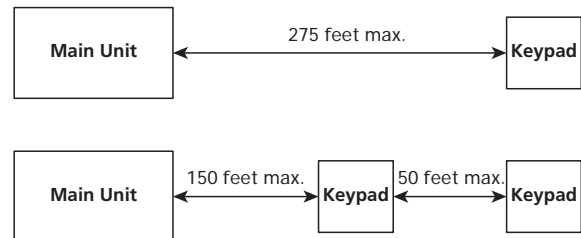

- When installing two Keypads, muting is available only on the Keypad to which the speaker cords are hooked up.

## IR emitter hookup

When you want to use the IR Remote Control for the Keypad without pointing it at the IR sensor of the Keypad, plug an IR emitter (not supplied) into the IR IN jack of the Keypad. Use an IR emitter with a power supply.

# Customizing the Keypad

## Setting bass and treble

You can adjust bass and treble to optimize the acoustic conditions in each zone.

- 1 Turn off the power.
- 2 Press and hold **MUTING** and **PAGE** simultaneously, and then press **POWER**.  
The LCD panel changes to the Bass and Treble setup mode.
- 3 Press the corresponding **SELECTION** button to adjust the bass and the treble.
- 4 Turn off the power when you have finished.  
The settings are confirmed when the power is turned off.



### Notes

- All other buttons, other than **VOLUME +**, **VOLUME -**, **MUTING** and **POWER**, are disabled while you are making settings.
- You can adjust Bass and Treble between  $\pm 14$  dB in 2 dB step.

## Setting volume limits

You can customize the volume limits to protect speakers from being over driven.

- 1 Turn off the power.
- 2 Press **SOURCE** and **LOCK** simultaneously, and then press **POWER**.  
The LCD panel changes to the Volume limitation mode.
- 3 Press the corresponding **SELECTION** button to adjust the maximum volume.
- 4 Turn off the power when you have finished.  
The settings are confirmed when the power is turned off.



### Notes

- All other buttons, other than **VOLUME +**, **VOLUME -**, **MUTING**, and **POWER**, are disabled while you are making settings.
- You can adjust the volume limits between level 64 and level 74.

## Adjusting LCD contrast

- 1 Turn off the power.
- 2 Press and hold **PLAY** and the **SELECT** button in the left-upper simultaneously, and then press **POWER**.  
The display window enters the contrast setting mode.
- 3 Press the corresponding **SELECTION** buttons to adjust the LCD Contrast Value.
- 4 Turn off the power when you have finished.  
The settings are confirmed when the power is turned off.

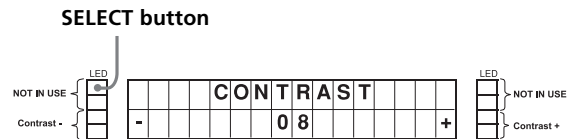

### Notes

- All buttons other than **POWER** are disabled while settings are being made.
- You can adjust the LCD contrast between level 01 and level 32.

## Adjusting brightness

You can make only a minor adjustment. Set the brightness of the display window to the adequate brightness level by inserting a flathead screwdriver into the bright adjustment hole. See page 11 for the location of the brightness adjustment hole.

## Turning all the zones off from the Keypad

- 1 Press and hold **POWER** until the figure below appears in the display window.
- 2 Press **YES** to turn off all of the zones.  
Press **No** to cancel the operation.  
All the zones turn off and the display window turns off automatically.



# Testing the Components

It is recommended that you test all the components before you finish with the installation of the entire system in each zone so as not to encounter any problems after the installation is completed. Check to see if the Main Unit, the installed components, and the Keypad operate properly by testing each operation.

## 1 Check the following connections.

- All the Keypads are connected to the Main Unit via CAT5 cables.
- An audio or a video component is connected between AUDIO IN Left/Right and VIDEO IN of each SOURCE connection jack.
- A display (output component) is connected to VIDEO OUT at each ZONE connection jack.
- Speakers are connected to SPEAKERS at each ZONE connection jack.
- An IR emitter is connected to IR OUT of each SOURCE connection jack, and is placed near the IR sensor of the source component.
- AC power cords for the Main Unit and the other components are plugged in.

## 2 Turn on the Main Unit.

## 3 Select ZONE 1 by pressing the ZONE button on the front panel of the Main Unit.

## 4 Select SOURCE 1 by pressing the SELECT SOURCE button on the front panel of the Main Unit.

## 5 Turn on the Keypad in zone 1.

## 6 Select SOURCE 1 by pressing the SELECT button on the Keypad. Then, check the following.

- Power control  
Press POWER to turn the Keypad on or off.
- Volume adjustment  
Press VOLUME +/- to adjust the volume.
- Muting  
Press MUTING to mute the speaker output.
- Playback operation  
Press the Play, Stop, Pause, and ◀▶/▶▶ buttons on the Keypad to confirm that the source component operates properly.
- Remote control operation  
Check that the remote control of the SOURCE 1 component works by pressing any command button while pointing the Remote Control toward the IR sensor of the Keypad. Then check that the SOURCE 1 component operates properly using the remote control.

## 7 Perform the test in each zone from zone 1 through zone 6 by repeating Steps 3 to 6.

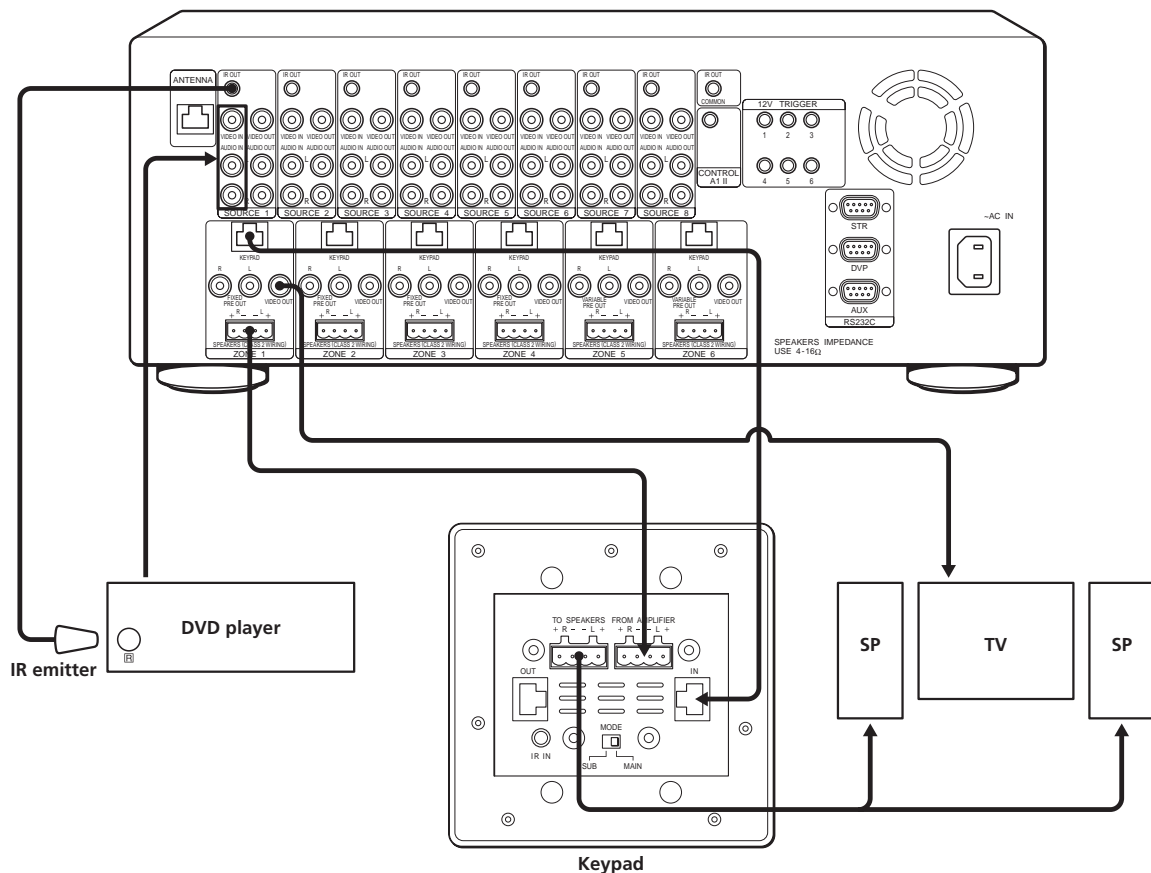

# Chapter 4

## Other Information

This chapter provides you with additional information that will help you understand and maintain your system.

---

### Precautions

#### On safety

- Should any solid object or liquid fall into the cabinet, unplug the player and have it checked by qualified personnel before operating it any further.
- The AC power cord must be changed only at a qualified service shop.
- The unit is not disconnected from the AC power source (mains) as long as it is connected to the wall outlet, even if the unit itself has been turned off.

#### On power sources

- Before operating the unit, check that the operating voltage of the unit is identical to that of your local power supply. The operating voltage is indicated on the nameplate on the back of the unit.
- If you are not going to use the unit for a long time, be sure to disconnect it from the AC power source (mains). To disconnect the mains lead, grasp the plug itself; never pull the cord.

#### On placement

- Place the unit in a location with adequate ventilation to prevent heat build-up in the Main Unit.
- Do not place the unit on a soft surface such as a rug that might block the ventilation holes on the bottom.
- Do not place the unit in a location near heat sources, or in a place subject to direct sunlight, excessive dust, or mechanical shock.

#### On adjusting the volume

- Do not turn up the volume too much while listening to audio with very low input levels or no audio signals. If you do, the speakers may be damaged when a peak level portion is played.

#### On cleaning

- Clean the cabinet, panel, and controls with a soft cloth slightly moistened with a mild detergent solution. Do not use any type of abrasive pad, scouring powder, or solvent, such as alcohol or benzine.

If you have any questions or problems concerning the Main Unit, please consult your nearest Sony dealer.

# Troubleshooting

If you experience any of the following difficulties while using the player, use this troubleshooting guide to help you to remedy the problem. Should any problem persist, consult your nearest Sony dealer.

## **There is no sound, no matter which component is selected.**

- ➔ Check that both the Main Unit and all components are turned on.
- ➔ Check that all speaker cords are connected correctly.
- ➔ Press MUTING to cancel the muting function.

## **There is no sound from a specific component.**

- ➔ Check that the component is connected correctly to the audio input jacks for that component.
- ➔ Check that the cord(s) used for the connection is (are) fully inserted into the jacks on both the receiver and the component.

## **There is no sound, or only a very low-level sound is heard.**

- ➔ Check that the speakers and components are connected securely.
- ➔ Check that you have selected the correct component on the Main Unit.
- ➔ Press MUTING if the muting function is activated.
- ➔ The protective device on the Main Unit has been activated because of a short circuit. Turn off the Main Unit, eliminate the short-circuit problem and turn the power on again.

## **The left and right sounds are unbalanced or reversed.**

- ➔ Check that the speakers and components are connected correctly and securely.

## **There is severe hum or noise.**

- ➔ Check that the speakers and components are connected securely.
- ➔ Check that the connecting cords are away from a transformer or motor, and at least 3 meters away from a TV set or fluorescent light.
- ➔ Move your TV away from the audio components.
- ➔ The plugs and jacks are dirty. Wipe them with a cloth slightly moistened with alcohol.

## **There is no picture, or an unclear picture appears on the TV screen or monitor.**

- ➔ Select the appropriate input on the Main Unit.
- ➔ Set your TV to the appropriate input mode.
- ➔ Move your TV away from the audio components.

## **The RF Remote Control does not function.**

- ➔ Make sure the RF antenna is connected securely to the Main Unit and placed in an appropriate position.
- ➔ Make sure you have selected the correct function on the Remote Control.

## **The IR Remote Control for the Keypad does not function.**

- ➔ Point the Remote Control at the remote sensor  on the Keypad.
- ➔ Remove any obstacles in the path between the Remote Control and the Keypad.
- ➔ Replace both batteries in the Remote Control with new ones, if they are weak.
- ➔ Check that you have selected the correct function on the Remote Control.

## **The source component does not respond to the Keypad operation.**

- ➔ Check that the IR emitter is connected to the IR OUT jack of the Main Unit.
- ➔ Check that the IR emitter is connected to the corresponding IR OUT jack of the source component.
- ➔ Check that the IR emitter is connected to the IR sensor of the source component.
- ➔ Check that the remote codes have been successfully learned by the Main Unit in the PC SETUP mode and the LEARN mode.



# Error Messages

## Main Unit

If any of the messages below appear on the Display window of the Main Unit, check the following table to solve the problem. If any problem persists, consult your nearest Sony dealer.

Message	Cause	Corrective action
PROTECTOR ZONE1	Protective device in zone 1 has been activated.	Turn off the Main Unit and check the speaker hookup.
PROTECTOR ZONE2	Protective device in zone 2 has been activated.	Turn off the Main Unit and check the speaker hookup.
PROTECTOR ZONE3	Protective device in zone 3 has been activated.	Turn off the Main Unit and check the speaker hookup.
PROTECTOR ZONE4	Protective device in zone 4 has been activated.	Turn off the Main Unit and check the speaker hookup.
PROTECTOR ZONE5	Protective device in zone 5 has been activated.	Turn off the Main Unit and check the speaker hookup.
PROTECTOR ZONE6	Protective device in zone 6 has been activated.	Turn off the Main Unit and check the speaker hookup.
FAN STOP	The fan does not rotate.	Turn off the Main Unit and check that if any objects are inside the fan unit.
CONNECTION ERROR STR	A communication error with the A/V Receiver (STR) has occurred.	An error occurred due to an unsupported connection.
CONNECTION ERROR DVD MEGA	A communication error with the DVD MEGA CHANGER has occurred.	An error occurred due to an unsupported connection.
CONNECTION ERROR CD MEGA	A communication error with the CD MEGA CHANGER has occurred.	An error occurred due to an unsupported connection.
CONNECTION ERROR PC	A communication error with the computer has occurred.	An error occurred due to an unsupported connection.
CONNECTION ERROR RF REMOTE	A confirmation error with the RF Remote Control has occurred.	Ask your nearest Sony dealer.
EEP ACCESS FAIL	The Main Unit failed to access the EEPROM.	Ask your nearest Sony dealer.
MEMORY FULL	The Memory capacity for storing EEPROM code has been exceeded during the remote code learning.	Some remote codes cannot be learned even if the memory capacity used for learning has not been exceeded.

## Keypad

If any of the messages below appear on the display window of the Keypad, check the following table to solve the problem. If any problem persists, consult your nearest Sony dealer.

Message	Cause	Corrective action
CONNECTION NOT ESTABLISHED	The Keypad failed to communicate with the Main Unit.	Turn off the Main Unit and check the CAT5 connections.
PROTECTOR	Protector is detected by the Main Unit.	Turn off the Main Unit and check the speaker connections.
FAN STOP	The fan of the Main Unit does not rotate.	Turn off the Main Unit and check that the ventilation holes are not covered.
PLEASE CHECK MODE SELECTOR	Mode selector switch setting is wrong.	Check that the Mode switch on the rear panel of the Keypad is in the correct position.
CANNOT ACCESS NOW	Multiple Keypads tried to access the same source component.	Wait for a few seconds and try again.
SOURCE NOT AVAILABLE!	An inactive source was selected.	Select the appropriate source connected to the Main Unit.
LOCKED BY OTHER ZONE	The selected source was locked by another zone.	You cannot operate a locked source until it is unlocked.
LOCKED BY MAIN ZONE	The selected source was locked by the main zone.	You cannot operate a locked source until it is unlocked.
NOT USED	An inactive button was selected.	Some buttons are not assigned for certain sources. ex.) PLAY cannot be operated in the TUNER position.

# Specifications

## CAV-M1000ES Main Unit

Audio (each channel)

Continuous average power output (FTC)

All channels: 30 W per channel min. RMS at 8 ohms, any two channels driven from 20 Hz to 20 kHz with no more than 0.09 % THD.

40 W per channel min. RMS at 4 ohms, any two channels driven from 20 Hz to 20 kHz with no more than 0.7 % THD.

Frequency response: 5 Hz to 70 kHz  $\pm$  3dB

Input sensitivity: 160 mV for 1 W output, 650 mV for full output (30 W) with volume control set to maximum.

Input impedance: 20 k ohms

Signal-to-noise ratio: 92 dB (A-weighted )

Bass control range: 100 Hz  $\pm$  14 dB, 2 dB step

Treble control range: 10 kHz  $\pm$  14 dB, 2 dB step

SOURCE 1-8 and ZONE 1-6 AUDIO OUT

Frequency response: 5 Hz to 55 kHz  $\pm$  3dB

THD @ 2 V: 0.08 %

Signal-to-noise ratio: 102 dB (A-weighted @ 2 V)

Video

Input/output impedance:

75 ohm

Video insertion loss: 0 dB (50 Hz - 6 MHz)

General

12V trigger: 300 mA max each zone, total 1.2 A max

Power requirements: 120 V 60 Hz

Power consumption: 540 W

Dimensions: 430  $\times$  175  $\times$  433 mm  
(16  $\frac{7}{8}$   $\times$  6  $\frac{7}{8}$   $\times$  17  $\frac{1}{16}$  inches)  
(w/h/d)

Mass: 24 kg (52 lbs 15 oz)

## RM-TP100 RF Remote Control

Interface system: Liquid crystal touch panel

Liquid crystal size: 5.2 inches (320  $\times$  240 dots)

Touch panel: Resistance sensible system  
Analog type

Maximum range from the RF Antenna:

7 m (22 feet 11  $\frac{1}{2}$  inches)

(The maximum range differs depending on the environment where you use the RF Remote Control.)

Power supply: Rechargeable (Ni-MH) battery

Maximum external dimensions:

227  $\times$  146  $\times$  45 mm

(9  $\times$  5  $\frac{3}{4}$   $\times$  1  $\frac{7}{8}$  inches)

(w/h/d, including projecting parts and controls)

Mass: 0.8 kg (1 lbs 13 oz)

(Main unit only, including the rechargeable battery)

Operating temperature:

5°C to 35°C (41°F to 95°F)

Design and specifications are subject to change without notice.

# Chapter 5

## Appendix

This chapter provides you with remote control code lists and concise information about operating the system.

---

### PRESET and LEARN Mode Code List

Following tables show preset remote control code for each source and common component. You can preset the remote control code using the CAV-M1000ES Editor and the RM-TP100 Editor software on your computer. You can also customize the remote control code by learning the original code of the component in the dashed area using the Main Unit and the Remote Control of the component.

# PRESET and LEARN Mode Code List

## Remote control source code

Remote control source codes are for source components. Source codes marked in dark gray can be preset only by a Sony product. Those codes marked in light gray below can be preset into the Sony products and the products of other manufacturers. However, some codes in light gray may not be available depending on the manufacturer, or may perform differently from the code command as it says.

Code ID	Contents and Display	Reference	Category						Compatibility with the IR Remote Control for the Keypad		
			DVD MEGA	TUNER (STR)	CD MEGA	DVD	CD	VCR		MD	
1	Code ID #001	-	-				-	-	-	-	
2	Code ID #002	Num1	Num1				Num1	Num1	Num1	Num1	Corresponding to Numeric key 1
3	Code ID #003	Num2	Num2				Num2	Num2	Num2	Num2	Corresponding to Numeric key 2
4	Code ID #004	Num3	Num3				Num3	Num3	Num3	Num3	Corresponding to Numeric key 3
5	Code ID #005	Num4	Num4				Num4	Num4	Num4	Num4	Corresponding to Numeric key 4
6	Code ID #006	Num5	Num5				Num5	Num5	Num5	Num5	Corresponding to Numeric key 5
7	Code ID #007	Num6	Num6				Num6	Num6	Num6	Num6	Corresponding to Numeric key 6
8	Code ID #008	Num7	Num7				Num7	Num7	Num7	Num7	Corresponding to Numeric key 7
9	Code ID #009	Num8	Num8				Num8	Num8	Num8	Num8	Corresponding to Numeric key 8
10	Code ID #010	Num9	Num9				Num9	Num9	Num9	Num9	Corresponding to Numeric key 9
11	Code ID #011	Num0	Num0				Num0	Num0	Num0	Num0	Corresponding to Numeric key 0
12	Code ID #012	>10					>10	>10	>10	>10	Corresponding to >10
13	Code ID #013	Num Enter	Enter				Enter	Enter	Enter	Enter	Corresponding to Enter
14	Code ID #014	Play	Play			Play	Play	Play	Play	Play	Corresponding to Play
15	Code ID #015	FF	FF			FF	FF	FF	FF	FF	Corresponding to FF
16	Code ID #016	REW	REW			REW	REW	REW	REW	REW	Corresponding to REW
17	Code ID #017	Stop	Stop			Stop	Stop	Stop	Stop	Stop	Corresponding to Stop
18	Code ID #018	Pause	Pause			Pause	Pause	Pause	Pause	Pause	Corresponding to Pause
19	Code ID #019	Prev	Prev	Ch -	Prev	Prev	Prev	Prev	Prev	Prev	Corresponding to Previous
20	Code ID #020	Next	Next	Ch +	Next	Next	Next	Next	Next	Next	Corresponding to Next
21	Code ID #021	Cursor Up	Cursor Up				Cursor Up	-	Cursor Up	-	Corresponding to ↑
22	Code ID #022	Cursor Down	Cursor Down				Cursor Down	-	Cursor Down	-	Corresponding to ↓
23	Code ID #023	Cursor right	Cursor right				Cursor right	-	Cursor right	-	Corresponding to →
24	Code ID #024	Cursor left	Cursor left				Cursor left	-	Cursor left	-	Corresponding to ←
25	Code ID #025	Cursor Enter	Enter				Enter	Enter	Enter	Enter	Corresponding to Cursor enter
26	Code ID #026	Return/Exit	Return				Exit	-	-	-	Corresponding to Return/Exit
27	Code ID #027	Menu	Menu				Menu	-	Menu	-	Corresponding to Menu
28	Code ID #028	Top menu/Guide	Top menu				Title	-	-	-	Corresponding to Top menu/Guide
29	Code ID #028	Display	Display				Display	Display	Display	Display	Corresponding to Display
30	Code ID #030	Folder	Folder				-	-	-	-	Corresponding to Folder
81	Code ID #081	F1					F1	F1	F1	F1	Corresponding to F1 key
82	Code ID #082	F2					F2	F2	F2	F2	Corresponding to F2 key
83	Code ID #083	F3					F3	F3	F3	F3	Compatible only with the RF Remote Control
110	Code ID #110	F30					F30	F30	F30	F30	

	Contents and Display	Reference	Category							Compatibility with the IR Remote Control for the Keypad
			LD	DAT	SAT	CABLE	TAPE	TUNER	VCD	
BASIC OPERATION	1 Code ID #001	-	-	-	-	-	-	-	-	
	2 Code ID #002	Num1	Num1	Num1	Num1	Num1	-	Num1	Num1	Corresponding to Numeric key 1
	3 Code ID #003	Num2	Num2	Num2	Num2	Num2	-	Num2	Num2	Corresponding to Numeric key 2
	4 Code ID #004	Num3	Num3	Num3	Num3	Num3	-	Num3	Num3	Corresponding to Numeric key 3
	5 Code ID #005	Num4	Num4	Num4	Num4	Num4	-	Num4	Num4	Corresponding to Numeric key 4
	6 Code ID #006	Num5	Num5	Num5	Num5	Num5	-	Num5	Num5	Corresponding to Numeric key 5
	7 Code ID #007	Num6	Num6	Num6	Num6	Num6	-	Num6	Num6	Corresponding to Numeric key 6
	8 Code ID #008	Num7	Num7	Num7	Num7	Num7	-	Num7	Num7	Corresponding to Numeric key 7
	9 Code ID #009	Num8	Num8	Num8	Num8	Num8	-	Num8	Num8	Corresponding to Numeric key 8
	10 Code ID #010	Num9	Num9	Num9	Num9	Num9	-	Num9	Num9	Corresponding to Numeric key 9
	11 Code ID #011	Num0	Num0	Num0	Num0	Num0	-	Num0	Num0	Corresponding to Numeric key 0
	12 Code ID #012	>10	>10	-	-	-	-	-	>10	Corresponding to >10
	13 Code ID #013	Num Enter	-	Enter	Key Enter	Enter	-	-	-	Corresponding to Enter
	14 Code ID #014	Play	Play	Play	-	-	Play	-	Play	Corresponding to Play
	15 Code ID #015	FF	FF	FF	-	-	FF	-	FF	Corresponding to FF
	16 Code ID #016	REW	REW	REW	-	-	REW	-	REW	Corresponding to REW
	17 Code ID #017	Stop	Stop	Stop	-	-	Stop	-	Stop	Corresponding to Stop
	18 Code ID #018	Pause	Pause	Pause	-	-	Pause	-	Pause	Corresponding to Pause
	19 Code ID #019	Prev	Prev	Prev	Ch -	Ch -	-	Ch -	Prev	Corresponding to Previous
	20 Code ID #020	Next	Next	Next	Ch +	Ch +	-	Ch +	Next	Corresponding to Next
	21 Code ID #021	Cursor Up	-	-	Cursor Up	-	-	-	-	Corresponding to ↑
	22 Code ID #022	Cursor Down	-	-	Cursor Down	-	-	-	-	Corresponding to ↓
	23 Code ID #023	Cursor right	-	-	Cursor right	-	-	-	-	Corresponding to →
	24 Code ID #024	Cursor left	-	-	Cursor left	-	-	-	-	Corresponding to ←
	25 Code ID #025	Cursor Enter	-	Enter	Key Enter	Enter	-	-	-	Corresponding to Cursor enter
	26 Code ID #026	Return/Exit	-	-	Menu Exit	-	-	-	Return	Corresponding to Return/Exit
	27 Code ID #027	Menu	-	-	Menu	-	-	-	-	Corresponding to Menu
	28 Code ID #028	Top menu/Guide	-	-	Guide	-	-	-	-	Corresponding to Top menu/Guide
	29 Code ID #028	Display	Display	-	Display	-	-	Display	-	Corresponding to Display
	30 Code ID #030	Folder	-	-	-	-	-	-	-	Corresponding to Folder
EXPAND	81 Code ID #081	F1	F1	F1	F1	F1	F1	F1	F1	Corresponding to F1 key
	82 Code ID #082	F2	F2	F2	F2	F2	F2	F2	F2	Corresponding to F2 key
	83 Code ID #083	F3	F3	F3	F3	F3	F3	F3	F3	Compatible only with the RF Remote Control
110 Code ID #110	F30	F30	F30	F30	F30	F30	F30	F30	F30	

**Notes**

- Sony's DVD MEGA and TUNER (STR) are the source components connected with RS232C cables.
- When you want to enter a remote control code for a TUNER (STR), connect its 2ND ROOM output to the source input of the Main Unit.
- CD MEGA is the source component connected with a CONTROL A1II cable.
- A command for a F1 and a F2 key of the IR Remote Control for the Keypad is allocated to the Code ID #081 and the Code ID #082 each.

# LEARN Mode Code List

## Remote control common code

Remote control common codes marked in dark gray can be preset only by a Sony product. Those codes marked in light gray below can be preset into the Sony products and the products of other manufacturers. However, some codes in light gray may not be available depending on the manufacturer, or may perform differently from the code command as it says.

Contents and Display	Reference	Category				
		TV	PROJECTOR	AMP	LIGHT	
1 Code ID #001	Power	Power	Power	Power	Power off	
2 Code ID #002	Num1	Num1	Input A	Video 1	Light1	
3 Code ID #003	Num2	Num2	Input B	Video 2	Light2	
4 Code ID #004	Num3	Num3	Input Video	Video 3	Light3	
5 Code ID #005	Num4	Num4	Input Select	Video 4	Light4	
6 Code ID #006	Num5	Num5	Memory	Video 5	Light5	
7 Code ID #007	Num6	Num6	Bright up	LD	Light6	
8 Code ID #008	Num7	Num7	Bright down	DVD	Light7	
9 Code ID #009	Num8	Num8	Contrast up	TV	Light8	
10 Code ID #010	Num9	Num9	Contrast down	TAPE	Light9	
11 Code ID #011	Num0	Num0	Zoom up	MD	Light10	
12 Code ID #012	>10	>10	Zoom down	CD	Light11	
13 Code ID #013	Num Enter	Enter	Shift up	TUNER	Light12	
14 Code ID #014	Play	-	Shift down	PHONO	Light13	
15 Code ID #015	FF	-	Focus up	iLink	Light14	
16 Code ID #016	REW	-	Focus down	Afd	Light15	
17 Code ID #017	Stop	-	-	2ch	Light16	
18 Code ID #018	Pause	-	-	A Direct	-	
19 Code ID #019	Prev	Ch -	-	Mode down	-	
20 Code ID #020	Next	Ch +	-	Mode up	-	
21 Code ID #021	Cursor Up	Cursor Up	Cursor Up	Cursor Up	Up	
22 Code ID #022	Cursor Down	Cursor Down	Cursor Down	Cursor Down	Down	
23 Code ID #023	Cursor right	Cursor right	Cursor right	Cursor right	-	
24 Code ID #024	Cursor left	Cursor left	Cursor left	Cursor left	-	
25 Code ID #025	Cursor Enter	-	Enter	Enter	-	
26 Code ID #026	Return/Exit	-	-	Movie	-	
27 Code ID #027	Menu	Menu	Menu	Menu	-	
28 Code ID #028	Top menu/Guide	-	-	Music	-	
29 Code ID #029	Display	Display	-	Display	-	
30 Code ID #030	-	-	-	Ttone	-	
31 Code ID #031		Recall	-	Eq	-	
32 Code ID #032		TV /VTR	-	On screen	-	
33 Code ID #033		Vol +	-	Vol +	-	
34 Code ID #034		Vol -	-	Vol -	-	
35 Code ID #035		Muting	-	Muting	-	
36 Code ID #036		Sleep	-	Sleep	-	
37 Code ID #037		Sub ch +	-	Surr Lev up	-	
38 Code ID #038		Sub ch -	-	Surr Lev down	-	
39 Code ID #039		P in P	-	Cen Lev up	-	
40 Code ID #040		Position	-	Cen Lev down	-	
41 Code ID #041		Wide	-	Audio Input	-	
42 Code ID #042		Swap	-	Audio Spilit	-	
43 Code ID #043		Execute	-	Input -	-	
44 Code ID #044		-	-	Input +	-	
45 Code ID #045		-	-	Night	-	
46 Code ID #046		-	-	Multi ch	-	
47 Code ID #047		-	-	Multi ch 2	-	
48 Code ID #048		-	-	Trg on	-	
49 Code ID #049		-	-	Trg off	-	
50 Code ID #050		-	-	-	-	
EXPAND	81 Code ID #081		F1	F1	F1	F1
	81					
	90 Code ID #090		F10	F10	F10	F10

BASIC OPERATION

EXPAND

# Using the RF Remote Control

Commands on the touch panel vary depending on the RF Remote Control programming.

## Turning the system on or off

- 1 Press **SYSTEM OFF**.  
"ALL OFF", "MAIN OFF", and "RETURN" appear on the touch panel.
- 2 Press **"ALL OFF"** when you want to turn off all zones, and press **"MAIN OFF"** when you want to turn off the main zone only.  
Press **"RETURN"** when you want to cancel the operation.

## Turning the RF Remote Control off

Leave the RF Remote Control alone for a few minutes.  
The RF Remote Control turns off automatically.

## Adjusting the volume

Press **VOLUME +/-** to the desired volume level.

## Muting the volume

Press **MUTING**.  
To cancel the muting, press **MUTING** again.

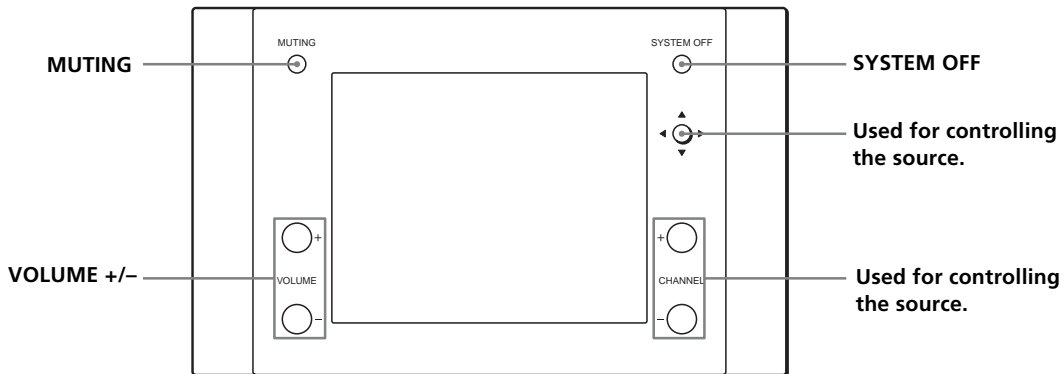

## Charging the internal battery

- 1 Attach the supplied ferrite core to the AC power cord of the charger cradle, then wrap the AC power cord twice around the ferrite core.
- 2 Connect the AC power cord of the charger cradle to the wall outlet.
- 3 Place the RF Remote Control on the charger cradle.  
The internal battery starts charging. It takes approximately 16 hours for full charging. Charge for considerable time when you use it for the first time.

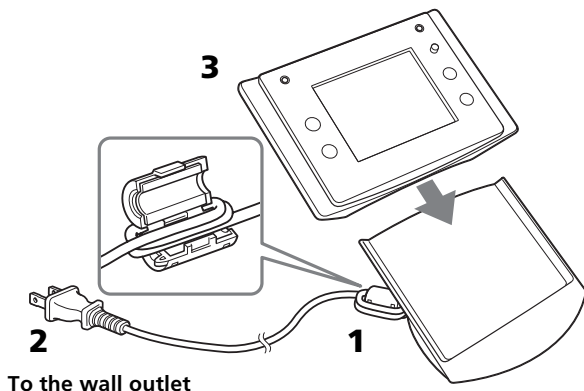

## Meaning of icons shown on the top of the display window

Icon	Meaning
	Communication between the RF Remote Control and the Main Unit is completed.
	Communication between the RF Remote Control and the Main Unit has been interfered with. Or the distance from the RF Remote Control to the RF Antenna is way too far. → Place the RF Antenna closer to the RF Remote Control. → Avoid interference of metal objects such as a cabinet between the RF Antenna and the RF Remote Control. Other radio waves have been interfering. → Move the RF Remote Control about 1 inch to the left to the right or up or down. Doing so may solve the problem.
	Some kind of trouble has occurred. Contact your nearest Sony dealer.
	The internal battery is being charged on the charger cradle.
	The remaining power of the battery is low. → Charge the battery by placing the RF Remote Control on the charger cradle.

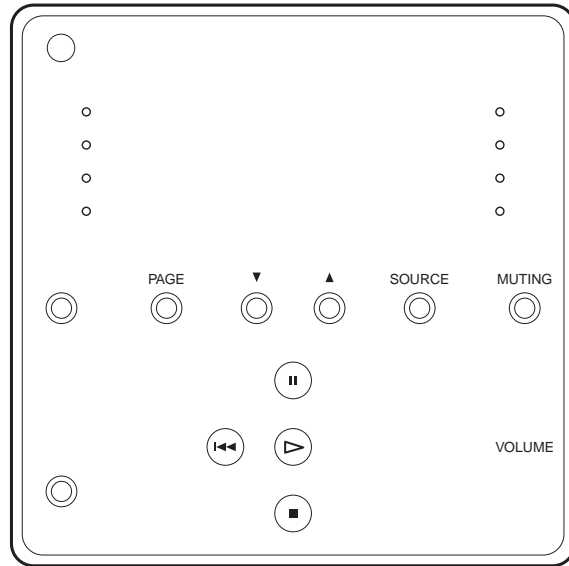



# Using the IR Remote Control for the Keypad

Buttons marked in gray are used to control the source components.

## Inserting batteries into the Remote Control

Insert two R06 (size-AA) batteries into the battery compartment with the + and – correctly oriented to the markings. When using the Remote, point it at the IR sensor  on the Keypad.

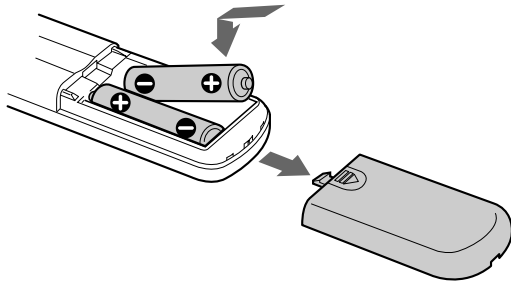

## When to replace the batteries

Under normal conditions, the batteries should last for about six months. When the remote no longer operates the player, replace both batteries with new ones.

### Notes

- Do not leave the Remote Control in an extremely hot or a humid place.
- Do not drop any foreign object into the Remote Control casing, particularly when replacing the batteries.
- Do not use a new battery with an old one.
- Do not expose the IR sensor to direct sunlight or lighting equipment. Doing so may cause a malfunction.
- If you do not intend to use the Remote Control for an extended period of time, remove the batteries to avoid possible damage from battery leakage and corrosion.

## Turning the Keypad on or off

Press  to turn the Keypad on.







To turn the Keypad off, press  again.

## Selecting and controlling the source

**1** Press **SELECT** next to the desired source displayed in the LCD window.

The selected source is activated.

**2** Press any of the following buttons to control the activated source component.

- : Operates the selected source component.
- : Pauses playback.
- : Stops playback.
-  / : Locates a specific track or preset station.
-  / : Locates a section you want to play within a track.

## Adjusting the volume

Press **MASTER VOL +/-** to the desired volume level.

## Muting the volume

Press **MUTING**.

To cancel the muting, press **MUTING** again or **VOLUME +**.

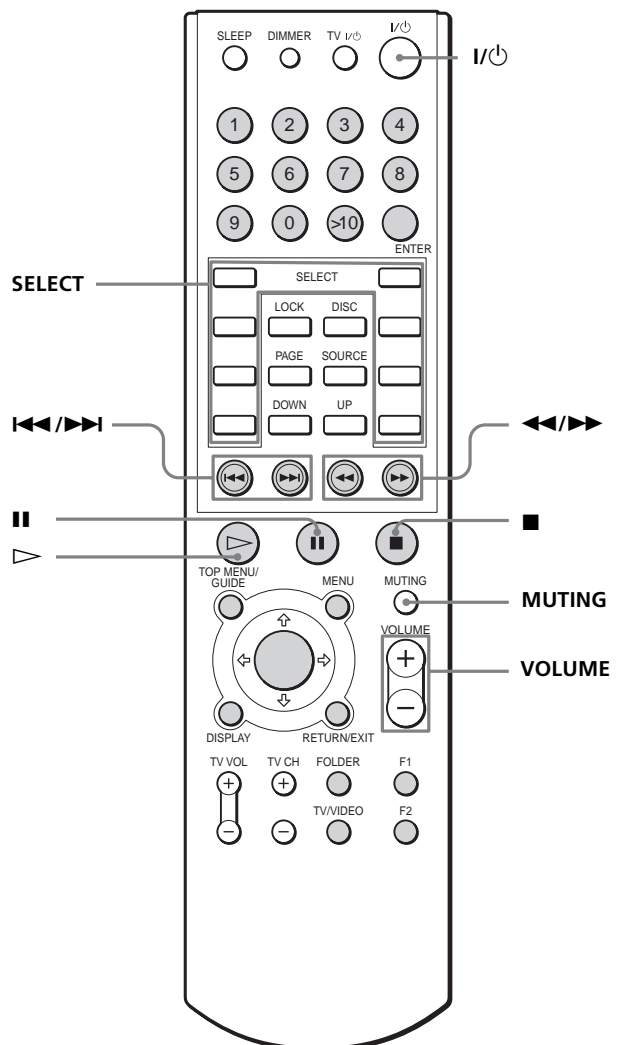

# Index

## A

- AC IN 9,18
- AC power cord 9, 18, 39
- Adding a new remote key 22
- Adjusting
  - Volume 19, 39, 40, 41
  - Source input offset 24
- ALL CLEAR 24, 25
- ALL ZONE MUTING button 7, 19
- ANTENNA jack 8
- AUDIO IN jack 8, 17
- AUDIO OUT jack 8, 18

## B

- BACK button 7
- Bass 29
- Battery 39, 41
- BAUD RATE SET 20

## C

- CANCEL button 7
- Charging the battery 39
- CHANNEL +/- button 9
- CHECK mode 23
- CIS VERSION 24
- CODE LEARNING 21
- CONTROL A1II jack 8, 17
- Cursor/ENTER button 7, 9, 12
- Customizing
  - Keypad 29
  - Main Unit 23

## D, E, F

- DIMMER button 12
- DISC
  - Button 12
  - DISC SEARCH 23
  - Information 23
- DISPLAY button 12
- Display window 7, 10
- ENTER button 7, 9, 12
- Error messages 33
- EXPAND CODE 22

- F1 button 12
- F2 button 12
- FIXED PRE OUT jack 9
- FOLDER button 12
- FROM AMPLIFIER jack 11

## H, I

- Hookup
  - AC power cord 18, 39
  - Keypad 18, 28
  - IR emitter 17, 18
  - Output components 18
  - RF Antenna 18
  - Source components 17
  - Speaker 18, 28
  - TV monitor 28
  - Zone related cables 18
- IN jack 11
- Initializing all the settings 25
- INSTALLATION mode 23
- Installing
  - Keypad 26
  - Main Unit 15
  - RF Antenna 16
- IR IN jack 11
- IR OUT jack 8, 17, 18
- IR Remote Control 12, 41
- IR sensor 10

## K, L, M

- Keypad 10, 26, 40
- KEYPAD jack 9, 18
- LCD contrast 29
- Learning the remote code 21
- LEARN mode code list 35, 36
- LOCK button 10
- Locking the settings 24
- MENU button 12
- MODE button 7
- MODE switch 11
- Mode indicator 7
- MUTING button 9, 10, 12

## O, P

OUT jack	11
PAGE button	10, 12
PAUSE button	10, 12
PC SETUP	20
Planning the system	14
PLAY button	10, 12
POWER switch	7, 10
Precautions	31
PROGRAM button	7

## R

Removing the Keypad	27
RS232C connector	7, 9, 17
RF Antenna	16, 18
RF Remote Control	9, 39

## S

SCROLL button	10
SELECT button	10, 12
Selecting the source	19
SETUP LOCK	24
SLEEP button	12
SOURCE button	10, 12
SOURCE INPUT OFFSET	24
SOURCE SELECT button	7, 19
SPEAKERS jack	9, 18
Specifications	34
STOP button	10, 12
SYSTEM OFF switch	9

## T, U, V, W, X, Y, Z

Testing	
Components	30
Learned remote code	23
TOP MENU/GUIDE button	12
TO SPEAKERS jack	11, 28
Treble	29
Troubleshooting	32
TV CH button	12
TV/VIDEO button	12
TV VOL button	12
Using	
IR Remote Control for the Keypad	41
Keypad	40
RF Remote Control	39
VARIABLE PREOUT jack	9
Version information	24
VIDEO IN jack	8, 17
VIDEO OUT jack	8, 9, 18
Volume limits	29
VOLUME +/- button	9, 10, 12
ZONE VOLUME +/- button	7
ZONE +/- button	7

## Numeral

12 V TRIGGER jack	8, 18
-------------------	-------



## Free Manuals Download Website

<http://myh66.com>

<http://usermanuals.us>

<http://www.somanuals.com>

<http://www.4manuals.cc>

<http://www.manual-lib.com>

<http://www.404manual.com>

<http://www.luxmanual.com>

<http://aubethermostatmanual.com>

Golf course search by state

<http://golfingnear.com>

Email search by domain

<http://emailbydomain.com>

Auto manuals search

<http://auto.somanuals.com>

TV manuals search

<http://tv.somanuals.com>