

Multi Channel AV Receiver

Operating Instructions

STR-DG910

©2007 Sony Corporation

Download from www.Somanuals.com. All Manuals Search And Download.

WARNING

To reduce the risk of fire or electric shock, do not expose this apparatus to rain or moisture.

To prevent fire, do not cover the ventilation of the apparatus with newspapers, table-cloths, curtains, etc. And don't place lighted candles on the apparatus.

To prevent fire or shock hazard, do not place objects filled with liquids, such as vases, on the apparatus.

Do not install the appliance in a confined space, such as a bookcase or built-in cabinet.

Install this system so that the power cord can be unplugged from the wall socket immediately in the event of trouble.



Don't throw away batteries with general house waste; dispose of them correctly as chemical waste.

For customers in Europe

Disposal of Old Electrical & Electronic Equipment (Applicable in the European Union and other European countries with separate collection systems)



This symbol on the product or on its packaging indicates that this product shall not be treated as household waste. Instead it shall be handed over to the applicable collection point for the recycling of electrical and electronic equipment. By ensuring this product is disposed of correctly, you will help prevent potential negative consequences for the environment and human health, which could otherwise be caused by inappropriate waste handling of this product. The recycling of materials will help to conserve natural resources. For more detailed information about recycling of this product, please contact your local Civic Office, your household waste disposal service or the shop where you purchased the product.

About This Manual

- The instructions in this manual are for model STR-DG910. Check your model number by looking at the lower right corner of the front panel. In this manual, models of area code E2 is used for illustration purposes unless stated otherwise. Any difference in operation is clearly indicated in the text, for example, "Models of area code CEL only".
- The instructions in this manual describe the controls on the supplied remote. You can also use the controls on the receiver if they have the same or similar names as those on the remote.

About area codes

The area code of the receiver you purchased is shown on the lower right portion of the rear panel (see the illustration below).

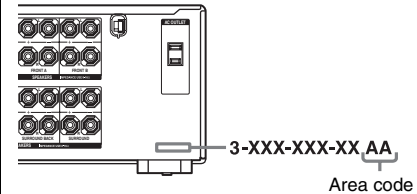

Any differences in operation, according to the area code, are clearly indicated in the text, for example, "Models of area code AA only".

This receiver incorporates Dolby* Digital and Pro Logic Surround and the DTS** Digital Surround System.

* Manufactured under license from Dolby Laboratories.

"Dolby", "Pro Logic", "Surround EX", and the double-D symbol are trademarks of Dolby Laboratories.

** "DTS" and "DTS-ES | Neo:6" are registered trademarks of DTS, Inc. "96/24" is a trademark of DTS, Inc.

This receiver incorporates High-Definition Multimedia Interface (HDMI™) technology. HDMI, the HDMI logo and High-Definition Multimedia Interface are trademarks or registered trademarks of HDMI Licensing LLC.

Table of Contents

Getting Started

Description and location of parts.....	4
1: Installing speakers	14
2: Connecting speakers.....	15
3a: Connecting the audio components.....	16
3b: Connecting the video components	19
4: Connecting the antennas.....	30
5: Preparing the receiver and the remote	31
6: Selecting the speaker system.....	33
7: Calibrating the appropriate settings automatically (AUTO CALIBRATION)	33
8: Adjusting the speaker levels and balance (TEST TONE)	39

Playback

Selecting a component.....	40
Listening/Watching a component.....	42

Amplifier Operations

Navigating through menus	44
Adjusting the level (LEVEL menu)	49
Adjusting the equalizer (EQ menu).....	50
Settings for the surround sound (SUR menu).....	50
Settings for the tuner (TUNER menu).....	52
Settings for the audio (AUDIO menu)	53
Settings for the video (VIDEO menu).....	54
Settings for the system (SYSTEM menu) ...	55

Enjoying Surround Sound

Enjoying Dolby Digital and DTS surround sound (AUTO FORMAT DIRECT).....	59
Selecting a pre-programmed sound field.....	61
Using only the front speakers (2CH STEREO).....	64
Listening to the sound without any adjustment (ANALOG DIRECT).....	64
Resetting sound fields to the initial settings.....	65

Tuner Operations

Listening to FM/AM radio.....	65
Presetting radio stations	67
Using the Radio Data System (RDS).....	69
(Models of area code CEL, CEK only)	

Other Operations

Switching between digital and analog audio (INPUT MODE)	71
Listening to digital sound from other inputs (DIGITAL ASSIGN)	72
Enjoying the DIGITAL MEDIA PORT (DMPORT)	73
Naming inputs.....	76
Changing the display	76
Using the Sleep Timer	77
Recording using the receiver	77

Using the Remote

Programming the remote	78
------------------------------	----

Additional Information

Glossary	83
Precautions.....	85
Troubleshooting	86
Specifications.....	90
Index	93

Description and location of parts

Front panel

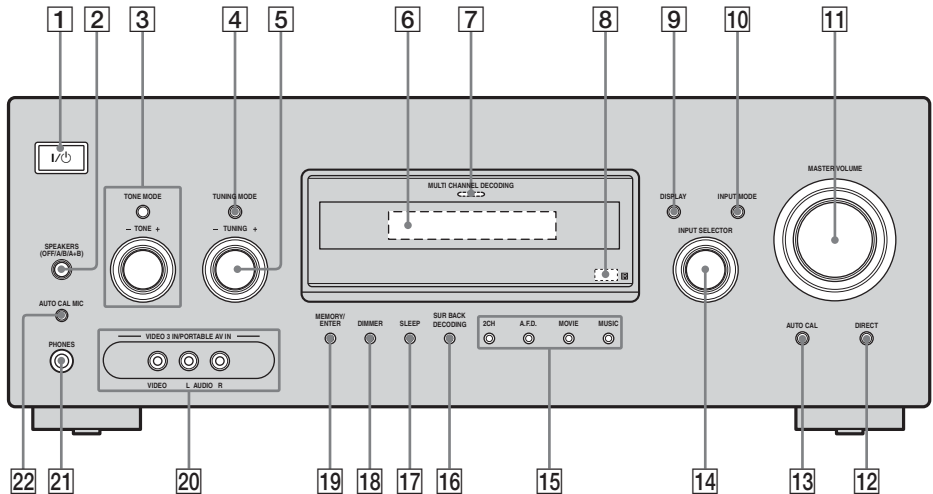

Name	Function
1 I/O (on/standby)	Press to turn the receiver on or off (page 32, 42, 43, 65).
2 SPEAKERS (OFF/A/B/A+B)	Press to select the speaker system (page 33).
3 TONE MODE TONE +/-	Adjusts the tonal quality (bass/treble level) of the front speakers. Press TONE MODE repeatedly to select bass or treble level, then turn TONE +/- to adjust the level (page 45).
4 TUNING MODE	Press to select the tuning mode (page 66, 68).
5 TUNING +/-	Turn to scan a station (page 66, 68).

Name	Function
6 Display	The current status of the selected component or a list of selectable items appears here (page 6).
7 MULTI CHANNEL DECODING lamp	Lights up when multi channel audio signals are decoded (page 43).
8 Remote sensor	Receives signals from remote commander.
9 DISPLAY	Press to select information displayed on the display (page 70, 76).
10 INPUT MODE	Press to select the input mode when the same components are connected to both digital and analog jacks (page 71).

Name	Function
11 MASTER VOLUME	Turn to adjust the volume level of all speakers at the same time (page 39, 41, 42, 43).
12 DIRECT	Press to listen to high quality analog sound (page 64).
13 AUTO CAL	Press to activate the Auto Calibration function (page 35).
14 INPUT SELECTOR	Turn to select the input source to playback (page 40).
15 2CH A.F.D. MOVIE MUSIC	Press to select a sound field (page 59, 61, 64).
16 SUR BACK DECODING	Press to select the surround back decoding mode (page 51).
17 SLEEP	Press to activate the Sleep Timer function and the duration which the receiver turns off automatically (page 77).
18 DIMMER	Press to adjust the brightness of the display (page 58).
19 MEMORY/ ENTER	Press to store a station or enter the selection when selecting the settings (page 32, 67).
20 VIDEO 3 IN/ PORTABLE AV IN jacks	Connects to a camcorder or video game (page 27, 41).
21 PHONES jack	Connects to headphones (page 87).
22 AUTO CAL MIC jack	Connects to the supplied optimizer microphone for the Auto Calibration function (page 34).

About the indicators on the display

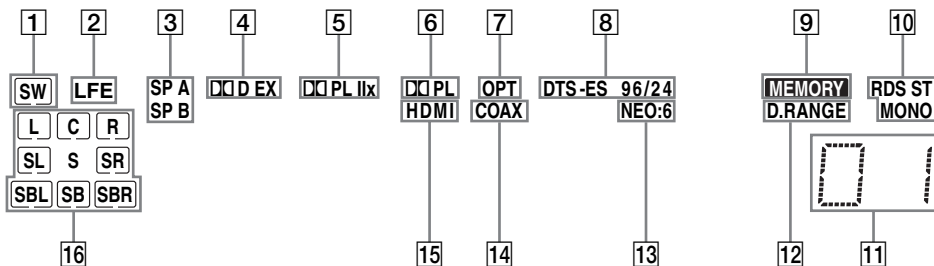

Name	Function
1 SW	Lights up when sub woofer is set to "YES" (page 47) and the audio signal is output from the SUB WOOFER jacks.
2 LFE	Lights up when the disc being played back contains an LFE (Low Frequency Effect) channel and the LFE channel signal is actually being reproduced.
3 SP A/SP B	Lights up according to the speaker system used (page 33). However, these indicators do not light up if the speaker output is turned off or if headphones are connected.
4 D D D (EX)	Lights up when the receiver is decoding Dolby Digital signals. "D D EX" lights up when the receiver is decoding Dolby Digital Surround EX signals. Note When playing a Dolby Digital format disc, be sure that you have made digital connections and that INPUT MODE is not set to "ANALOG" (page 71).

Name	Function
5 D D PL II (x)	Lights up when the Pro Logic II Movie/Music/Game decoder is activated. "D D PL IIx" lights up when the Pro Logic IIx Movie/Music/Game decoder is activated. However, these indicators do not light up if both the center and surround speakers are set to "NO" (page 47) and you select a sound field using the A.F.D. button. Note Dolby Pro Logic IIx decoding does not function for signals with a sampling frequency of more than 48 kHz.
6 D D PL	Lights up when the receiver applies Pro Logic processing to 2 channel signals in order to output the center and surround channel signals. However, these indicators do not light up if both the center and surround speakers are set to "NO" (page 47) and you select a sound field using the A.F.D. button.
7 OPT	Lights up when INPUT MODE is set to "AUTO IN" and the source signal is a digital signal being input through the OPTICAL jack, or when INPUT MODE is set to "OPT IN" (page 71).

Name	Function
8 DTS (-ES)/ (96/24)	Lights up when the receiver is decoding DTS signals. "DTS-ES" lights up when the receiver is decoding DTS-ES signals. "DTS 96/24" lights up when the receiver is decoding DTS 96 kHz/24 bit signals. Note When playing a DTS format disc, be sure that you have made digital connections and that INPUT MODE is not set to "ANALOG" (page 71).
9 MEMORY	Lights up when a memory function, such as Preset Memory (page 67), etc., is activated.
10 Tuner indicators	Lights up when using the receiver to tune in radio stations (page 65), etc. Note "RDS" lights up for models of area code CEL, CEK only.
11 Preset station indicators	Lights up when using the receiver to tune in preset radio stations. For details on presetting radio stations, see page 67.
12 D.RANGE	Lights up when dynamic range compression is activated (page 45).
13 NEO:6	Lights up when DTS Neo:6 Cinema/Music decoder is activated (page 60).
14 COAX	Lights up when INPUT MODE is set to "AUTO IN" and the source signal is a digital signal being input through the COAXIAL jack, or when INPUT MODE is set to "COAX IN" (page 71).
15 HDMI	Lights up when the receiver recognizes a component connected via a HDMI IN jack (page 20).

Name	Function
16 Playback channel indicators	The letters (L, C, R, etc.) indicate the channels being played back. The boxes around the letters vary to show how the receiver downmixes the source sound (based on the speaker settings).
L	Front Left
R	Front Right
C	Center (monaural)
SL	Surround Left
SR	Surround Right
S	Surround (monaural or the surround components obtained by Pro Logic processing)
SBL	Surround Back Left
SBR	Surround Back Right
SB	Surround Back (the surround back components obtained by 6.1 channel decoding)
	Example: Recording format (Front/ Surround): 3/2.1 Output channel: When surround speakers are set to "NO" (page 47) Sound Field: A.F.D. AUTO
	<p>The diagram shows a speaker layout with indicators: SW (top), L (left), C (center), R (right), SL (bottom left), and SR (bottom right). Each indicator is enclosed in a box.</p>

Rear panel

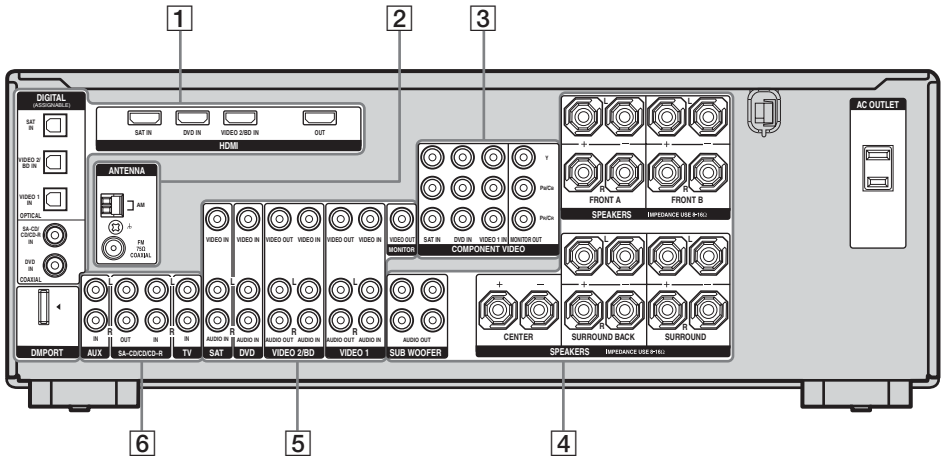

1 DIGITAL INPUT/OUTPUT section



OPTICAL IN jacks Connects to a DVD player, etc. The COAXIAL jack provides a better quality of loud sound (page 24, 26).



COAXIAL IN jacks



HDMI IN/OUT jacks* Connects to a DVD player, satellite tuner, or a Blu-ray disc player. The image and the sound are output to a TV or a projector (page 20).



DMPORT jack Connects to a DIGITAL MEDIA PORT adapter (page 74).

2 ANTENNA section



FM ANTENNA jack Connects to the FM wire antenna supplied with this receiver (page 30).



AM ANTENNA terminals Connects to the AM loop antenna supplied with this receiver (page 30).

3 COMPONENT VIDEO INPUT/OUTPUT section



Green (Y) COMPONENT Connects to a DVD player, TV, satellite tuner, etc.



Blue (P_B/C_B) INPUT/OUTPUT jacks* You can enjoy high quality image (page 22–26).



Red (P_R/C_R)

4 SPEAKERS section



Connects to speakers (page 15).



Connects to sub woofers (page 15).

5 VIDEO/AUDIO INPUT/OUTPUT section



White (L) AUDIO IN/OUT jacks

Connects to the video and audio jacks of a VCR, DVD player, etc. (page 22 – 27).



Red (R)



Yellow VIDEO IN/OUT jacks*

6 AUDIO INPUT/OUTPUT section



White (L) AUDIO IN/OUT jacks

Connects to a Super Audio CD player, CD recorder, etc. (page 17, 18, 22).



Red (R)

* You can watch the selected input image when you connect the HDMI OUT or MONITOR OUT jack to a TV (page 22).

Remote commander

You can use the supplied remote to operate the receiver and to control the Sony audio/video components that the remote is assigned to operate.

You can also program the remote to control non-Sony audio/video components. For details, see “Programming the remote” (page 78).

RM-AAP017

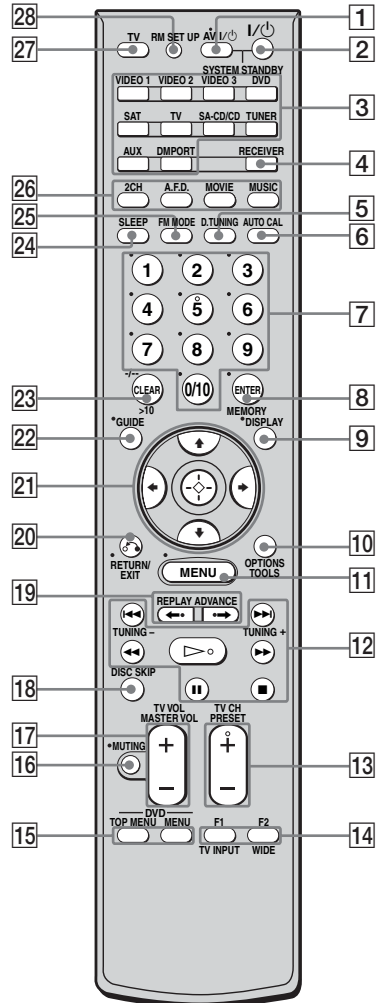

continued













Name	Function																						
1 AV I/⏻ (on/standby)	<p>Press to turn on or off the audio/video components that the remote is programmed to operate.</p> <p>To turn the TV on or off, press TV (27) and then press AV I/⏻.</p> <p>If you press I/⏻ (2) at the same time, it will turn off the receiver and other components (SYSTEM STANDBY).</p> <p>Note The function of the AV I/⏻ switch changes automatically each time you press the input buttons (3).</p>																						
2 I/⏻ (on/standby)	<p>Press to turn the receiver on or off.</p> <p>To turn off all components, press I/⏻ and AV I/⏻ (1) at the same time (SYSTEM STANDBY).</p>																						
3 Input buttons	<p>Press one of the buttons to select the component you want to use. When you press any of the input buttons, the receiver turns on. The buttons are factory assigned to control Sony components as follows. You can program the remote to control non-Sony components following the steps in “Programming the remote” on page 78.</p> <table border="1"> <thead> <tr> <th>Button</th> <th>Assigned Sony component</th> </tr> </thead> <tbody> <tr> <td>VIDEO 1</td> <td>VCR (VTR mode 3)</td> </tr> <tr> <td>VIDEO 2</td> <td>VCR (VTR mode 2)</td> </tr> <tr> <td>VIDEO 3</td> <td>VCR (VTR mode 1)</td> </tr> <tr> <td>DVD</td> <td>DVD player</td> </tr> <tr> <td>SAT</td> <td>Satellite tuner</td> </tr> <tr> <td>TV</td> <td>TV</td> </tr> <tr> <td>SA-CD/CD</td> <td>Super Audio CD/CD player</td> </tr> <tr> <td>TUNER</td> <td>Built-in tuner</td> </tr> <tr> <td>AUX</td> <td>Not assigned</td> </tr> <tr> <td>DMPOR T</td> <td>DIGITAL MEDIA PORT adapter</td> </tr> </tbody> </table>	Button	Assigned Sony component	VIDEO 1	VCR (VTR mode 3)	VIDEO 2	VCR (VTR mode 2)	VIDEO 3	VCR (VTR mode 1)	DVD	DVD player	SAT	Satellite tuner	TV	TV	SA-CD/CD	Super Audio CD/CD player	TUNER	Built-in tuner	AUX	Not assigned	DMPOR T	DIGITAL MEDIA PORT adapter
Button	Assigned Sony component																						
VIDEO 1	VCR (VTR mode 3)																						
VIDEO 2	VCR (VTR mode 2)																						
VIDEO 3	VCR (VTR mode 1)																						
DVD	DVD player																						
SAT	Satellite tuner																						
TV	TV																						
SA-CD/CD	Super Audio CD/CD player																						
TUNER	Built-in tuner																						
AUX	Not assigned																						
DMPOR T	DIGITAL MEDIA PORT adapter																						





















Name	Function
4 RECEIVER	Press to activate the receiver operation (page 44).
5 D.TUNING	Press to enter direct tuning mode.
6 AUTO CAL	Press to activate the Auto Calibration function.
7 Numeric buttons (number 5^a)	<p>Press to</p> <ul style="list-style-type: none"> – preset/tune to preset stations. – select track numbers of the CD player, VCD player, LD player, DVD player, MD deck, DAT deck, or tape deck. Press 0/10 to select track number 10. – select channel numbers of the VCR, satellite tuner, Blu-ray disc recorder, PSX, DVD/VHS COMBO, or DVD/HDD COMBO. <p>Press TV (27) and then press the numeric buttons to select the TV channels.</p>
8 ENTER	<p>Press to enter the value after selecting a channel, disc or track using the numeric buttons of the VCR, CD player, VCD player, LD player, MD deck, DAT deck, tape deck, satellite tuner, Blu-ray disc recorder, or PSX.</p> <p>To enter the value of Sony TV, press TV (27) and then press ENTER.</p>
MEMORY	Press to store a station during tuner operation.
9 DISPLAY	<p>Press to select information displayed on the TV screen of the VCR, VCD player, LD player, DVD player, CD player, MD deck, Blu-ray disc recorder, PSX, satellite tuner, DVD/VHS COMBO, or DVD/HDD COMBO.</p> <p>To select information of Sony TV, press TV (27) and then press DISPLAY.</p>

Name	Function
10 OPTIONS TOOLS	Press to display and select items from the option menus for DVD player or DVD/VHS COMBO. To display the options of Sony TV, press TV (27) and then press OPTIONS TOOLS.
11 MENU	Press to display the menus of the receiver, VCR, DVD player, satellite tuner, Blu-ray disc recorder, PSX, DVD/VHS COMBO, or DVD/HDD COMBO on the TV screen. Then, use $\blacktriangleleft/\blacktriangleright/\blacktriangleleft/\blacktriangleright$ and \oplus to perform menu operations. To display the menus of Sony TV, press TV (27) and then press MENU.
12 $\blacktriangleleft/\blacktriangleright/\blacktriangleleft/\blacktriangleright$ ^{b)}	Press to skip tracks of the VCR, CD player, VCD player, LD player, DVD player, MD deck, DAT deck, tape deck, Blu-ray disc recorder, PSX, DVD/VHS COMBO, or DVD/HDD COMBO.
$\blacktriangleleft/\blacktriangleright/\blacktriangleleft/\blacktriangleright$ ^{b)}	Press to – search tracks in the forward/backward direction of the CD player, VCD player, DVD player, LD player, MD deck, Blu-ray disc recorder, PSX, DVD/VHS COMBO, or DVD/HDD COMBO. – fast forward/rewind of the VCR, DAT deck, or tape deck.
\blacktriangleright ^{a)b)}	Press to start playback of the VCR, CD player, VCD player, LD player, DVD player, MD deck, DAT deck, tape deck, Blu-ray disc recorder, PSX, DVD/VHS COMBO, or DVD/HDD COMBO.

Name	Function
\blacksquare ^{b)}	Press to pause playback or recording of the VCR, CD player, VCD player, LD player, DVD player, MD deck, DAT deck, tape deck, Blu-ray disc recorder, PSX, DVD/VHS COMBO, or DVD/HDD COMBO. (Also starts recording with components in recording standby.)
\blacksquare ^{b)}	Press to stop playback of the VCR, CD player, VCD player, LD player, DVD player, MD deck, DAT deck, tape deck, Blu-ray disc recorder, PSX, DVD/VHS COMBO, or DVD/HDD COMBO.
TUNING +/-	Press to scan a station.
13 TV CH +^{a)}/-	Press TV (27) and then press TV CH +/- to select preset TV channels.
PRESET +^{a)}/-	Press to – select preset stations. – select preset channels of the VCR, satellite tuner, Blu-ray disc recorder, DVD player, DVD/VHS COMBO, or DVD/HDD COMBO.
14 F1, F2	Press F1 or F2 to select a component. <ul style="list-style-type: none"> • DVD/HDD COMBO F1: HDD mode F2: DVD mode • DVD/VHS COMBO F1: DVD mode F2: VHS mode
TV INPUT	Press TV (27) and then press TV INPUT to select the input signal (TV input or video input).
WIDE	Press TV (27) and then press WIDE to select the wide picture mode.

continued

Name	Function
15 DVD TOP MENU	Press to display the menu or on-screen guide of the DVD player on the TV screen. Then, use  /  /  and  to perform menu operations.
DVD MENU	Press to display the menu of the DVD player on the TV screen. Then, use  /  /  and  to perform menu operations.
16 MUTING	Press to mute the sound (page 41). To mute the sound of the TV, press TV () and then press MUTING.
17 TV VOL +/-	Press TV () and then press TV VOL +/- to adjust the TV volume level.
MASTER VOL +/-	Press to adjust the volume level of all speakers at the same time.
18 DISC SKIP	Press to skip disc of the CD player, VCD player, DVD player, or MD deck (multi-disc changer only).
19 REPLAY ←-/ ADVANCE →	Press to replay the previous scene or fast forward the current scene of the DVD player, Blu-ray disc recorder, DVD/VHS COMBO, or DVD/HDD COMBO.
20 RETURN/ EXIT ↶	Press to – return to the previous menu. – exit the menu while the menu or on-screen guide of the VCD player, LD player, DVD player, Blu-ray disc recorder, PSX, DVD/VHS COMBO, or satellite tuner is displayed on the TV screen. To return to the previous menu of Sony TV, press TV () and then press RETURN/EXIT  .

Name	Function
21  ,  /  /  / 	After pressing RECEIVER () , press MENU () for receiver operation, then press  /  /  /  to select the settings. After pressing DVD TOP MENU () or DVD MENU () , press  /  /  /  to select the settings, and then press  to enter the selection. Press  also to enter the selection of the receiver, VCR, satellite tuner, DVD player, Blu-ray disc recorder, PSX, DVD/VHS COMBO, or DVD/HDD COMBO.
22 GUIDE	Press to display the EPG (Electronic Program Guide) of the TV, DVD player, satellite tuner, Blu-ray disc recorder, PSX, or DVD/HDD COMBO.
23 CLEAR	Press to clear a mistake when you press the incorrect numeric button of the DVD player, Blu-ray disc recorder, PSX, satellite tuner, DVD/VHS COMBO, or DVD/HDD COMBO.
-/--	Press to select the channel entry mode, either one or two digit of the VCR or satellite tuner. To select the channel entry mode of the TV, press TV () and then press -/--.
>10	Press to select track numbers over 10 of the CD player, VCD player, LD player, MD deck, tape deck, TV, VCR, or satellite tuner.
24 SLEEP	Press to activate the Sleep Timer function and the duration which the receiver turns off automatically.
25 FM MODE	Press to select FM monaural or stereo reception.
26 2CH A.F.D. MOVIE MUSIC	Press to select a sound field (page 59, 61, 64)

Name	Function
27 TV	Press to light up the button. It changes the remote key function to activate the buttons with orange printing. It also activate the DISPLAY (9), OPTIONS TOOLS (10), MENU (11), RETURN/EXIT ↵ (20), ⊕ (21), and ↕/↔/↔/↔ (21) buttons to perform menu operations for Sony TVs only.
28 RM SET UP	Press to set up the remote.

- a) The number 5, TV CH +, PRESET + and ▷ buttons have tactile dots. Use the tactile dots as references when operating the receiver.
- b) This button is also available for DIGITAL MEDIA PORT adapter operation. For details on the function of the button, see the operating instructions supplied with the DIGITAL MEDIA PORT adapter.

Notes

- Some functions explained in this section may not work depending on the model.
- The above explanation is intended to serve as an example only. Therefore, depending on the component, the above operation may not be possible or may operate differently than described.

1: Installing speakers

This receiver allows you to use a 7 channel speaker with 4 sub woofer system.

Enjoying a 5.1/7.1 channel system

To fully enjoy theater-like multi channel surround sound requires five speakers (two front speakers, a center speaker, and two surround speakers) and a sub woofer (5.1 channel).

Example of a 5.1 channel speaker system configuration

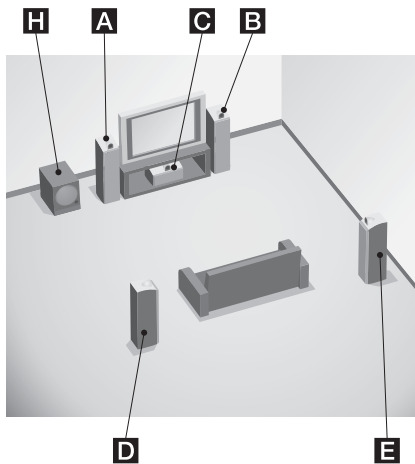

- A** Front speaker (Left)
- B** Front speaker (Right)
- C** Center speaker
- D** Surround speaker (Left)
- E** Surround speaker (Right)
- H** Sub woofer

You can enjoy high fidelity reproduction of DVD software recorded sound in the Surround EX format if you connect one additional surround back speaker (6.1 channel) or two surround back speakers (7.1 channel) (see “Using the surround back decoding mode” on page 51).

Example of a 7.1 channel speaker system configuration

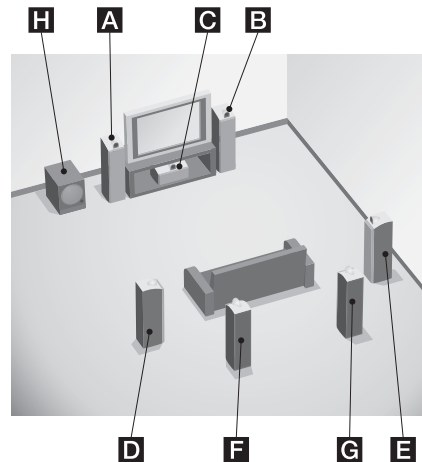

- A** Front speaker (Left)
- B** Front speaker (Right)
- C** Center speaker
- D** Surround speaker (Left)
- E** Surround speaker (Right)
- F** Surround back speaker (Left)
- G** Surround back speaker (Right)
- H** Sub woofer

Tips

- When you connect a 6.1 channel speaker system, place the surround back speaker behind the listening position.
- Since the sub woofer does not emit highly directional signals, you can place it wherever you want.

2: Connecting speakers

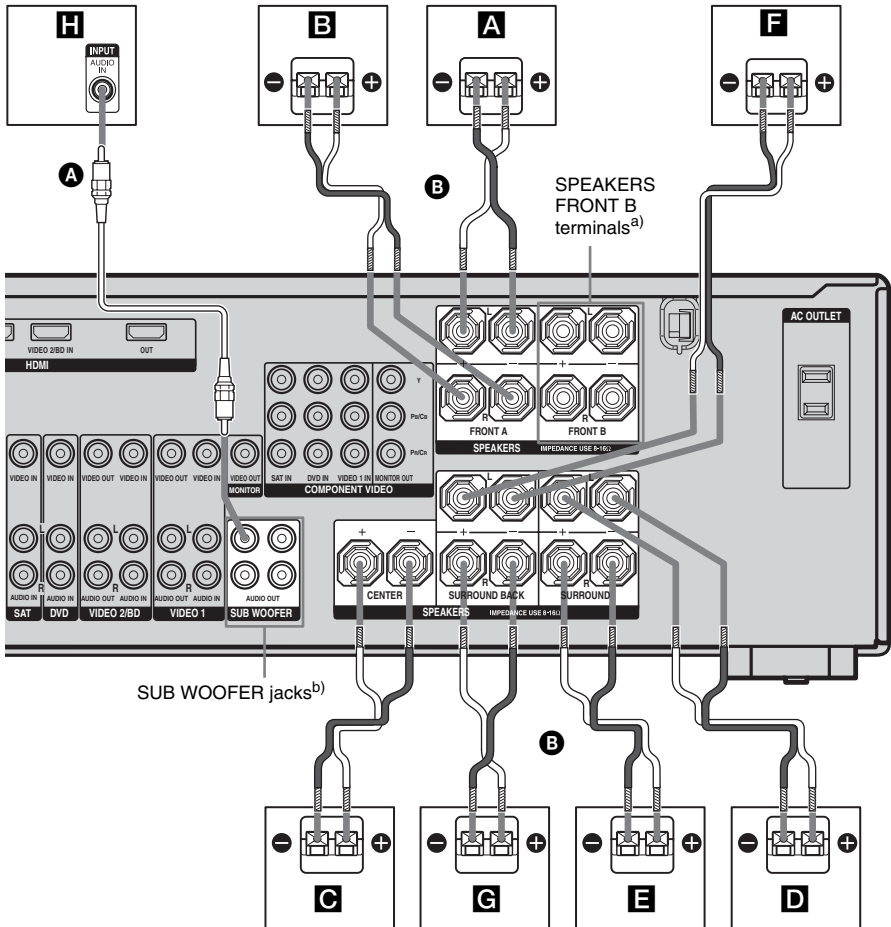

- A** Monaural audio cord (not supplied)
- B** Speaker cord (not supplied)

- A** Front speaker A (Left)
- B** Front speaker A (Right)
- C** Center speaker
- D** Surround speaker (Left)

- E** Surround speaker (Right)
- F** Surround back speaker (Left)^(c)
- G** Surround back speaker (Right)^(c)
- H** Sub woofer^(d)

continued

- a) If you have an additional front speaker system, connect them to the SPEAKERS FRONT B terminals. You can select the front speakers you want to use with the SPEAKERS (OFF/A/B/A+B) button on the receiver (page 33).
- b) If you have an additional sub woofer, connect it to any of the SUB WOOFER jacks. You can connect up to 4 sub woofers.
- c) If you connect only one surround back speaker, connect it to the SPEAKERS SURROUND BACK L terminals.
- d) When you connect a sub woofer with an auto standby function, turn off the function when watching movies. If the auto standby function is set to on, it turns to standby mode automatically based on the level of the input signal to a sub woofer, then sound may not be output.

3a: Connecting the audio components

How to connect your components

This section describes how to connect your audio components to this receiver. Before you begin, refer to “Component to be connected” below for the pages which describe how to connect each component.

After connecting your audio component, proceed to “3b: Connecting the video components” (page 19) or “4: Connecting the antennas” (page 30).

Component to be connected

Component	With	Page
Super Audio CD player/ CD player/ CD recorder	Digital audio output ^{a)}	17
	Analog audio output only ^{b)}	18
MD deck, tape deck, etc.	Analog audio output only ^{b)}	18

^{a)} Model with DIGITAL COAXIAL OUTPUT jack etc.

^{b)} Model equipped only with AUDIO OUT L/R jacks, etc.

Connecting components with digital audio output jack

The following illustration shows how to connect a Super Audio CD player, CD player or CD recorder.

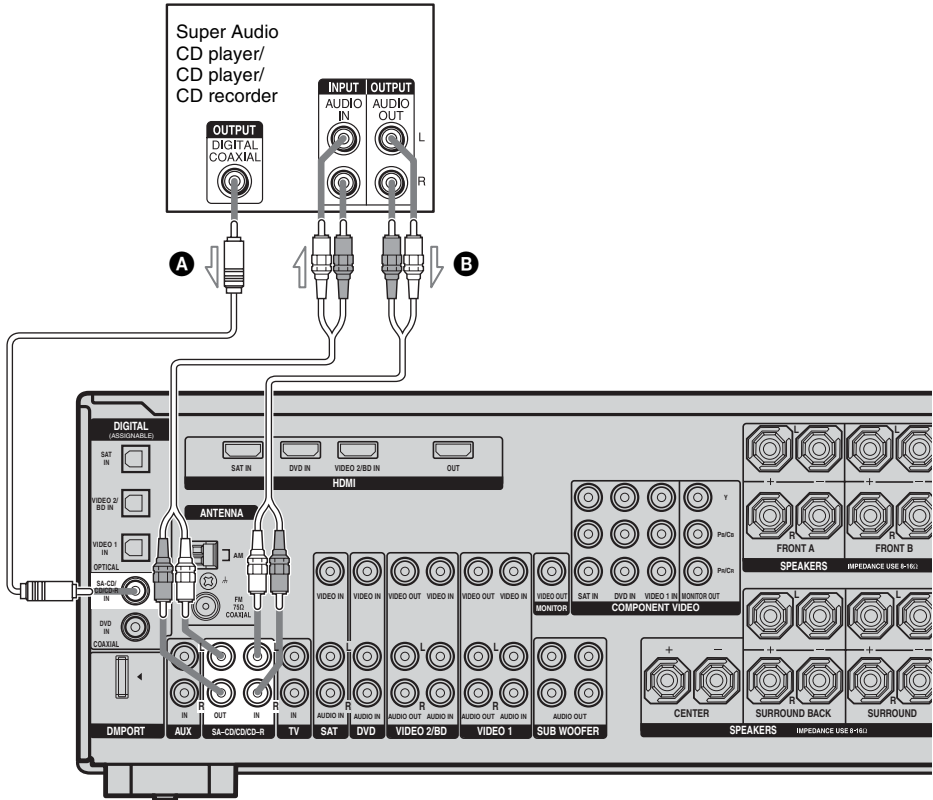

- A** Coaxial digital cord (not supplied)
- B** Audio cord (not supplied)

Notes

- When you play back a Super Audio CD disc on a Super Audio CD player, the sound is output only if you make the connection to SA-CD/CD/CD-R IN jacks (analog input jack) on the receiver. Refer to the operating instructions supplied with the Super Audio CD player.
- You can only make analog recording on this receiver.

Tip

All the digital audio jacks are compatible with 32 kHz, 44.1 kHz, 48 kHz, and 96 kHz sampling frequencies.

Connecting components with analog audio jacks

The following illustration shows how to connect a component which has analog jacks such as tape deck, etc.

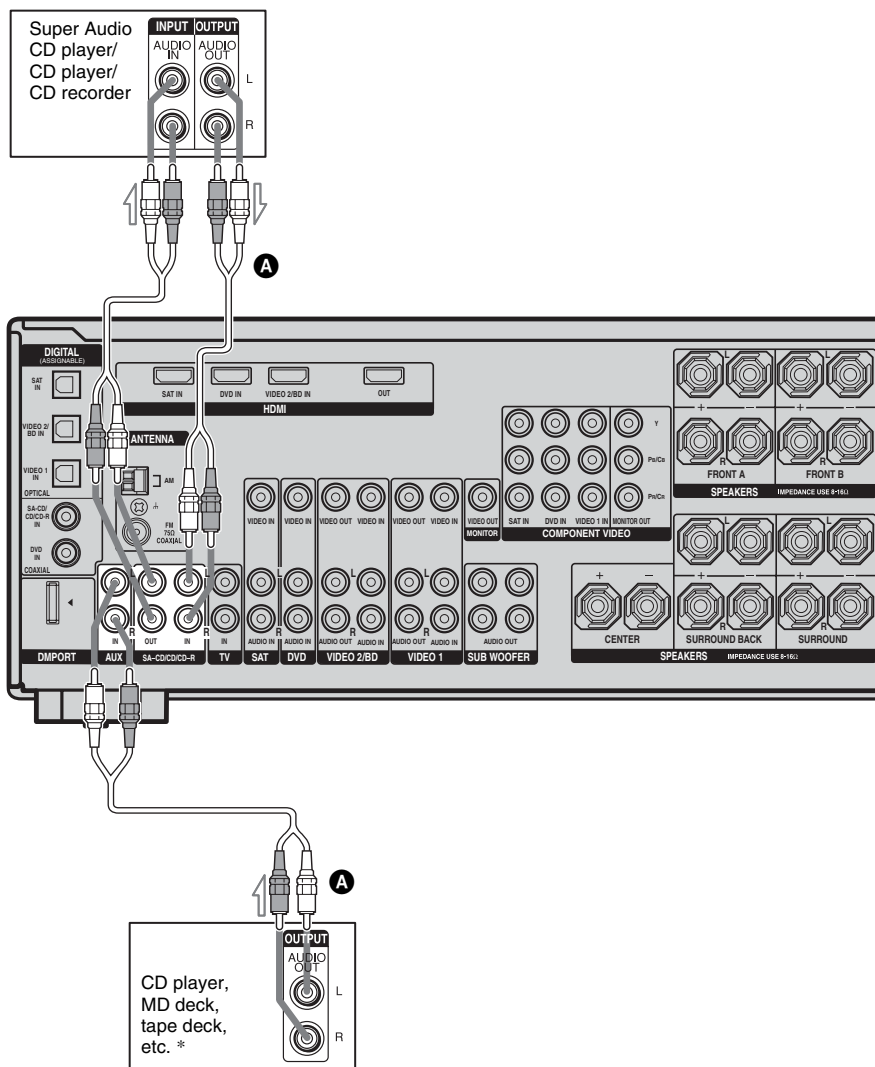

A Audio cord (not supplied)

* You can connect an audio component (except turntable) to the AUX IN jack so that you can listen to stereo sources in surround sound.

3b: Connecting the video components

How to connect your components

This section describes how to connect your video components to this receiver. Before you begin, refer to “Component to be connected” below for the pages which describe how to connect each component.

After connecting all your components, proceed to “4: Connecting the antennas” (page 30).

Component to be connected

Component	Page
With HDMI jack	20
TV	22
DVD player/DVD recorder	24
Satellite tuner/Set-top box	26
VCR	27
Camcorder, video game, etc.	27

Video input/output jack to be connected

The image quality depends on the connecting jack. Refer to the illustration that follows. Select the connection according to the jacks on your components.

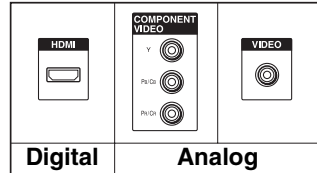

Notes

- Connect image display components such as a TV or a projector to the HDMI OUT or MONITOR OUT jack on the receiver.
- Be sure to turn on the receiver when the video and audio of a playback component are being output to a TV via the receiver. If the power supply of the receiver is not turned on, neither video nor audio is transmitted.

Converting video signals

This receiver is equipped with a function for up-converting video signals. For details, see page 28.

Connecting components with HDMI jacks

HDMI is the abbreviated name for High-Definition Multimedia Interface. It is an interface which transmits video and audio signals in digital format.

HDMI features

- A digital audio signals transmitted by HDMI can be output from the speakers connected to the receiver. This signal supports Dolby Digital, DTS, and linear PCM.
- Analog video signals input to the VIDEO jack or COMPONENT VIDEO jacks can be output as HDMI signals. Audio signals are not output from an HDMI OUT jack when the image is converted.

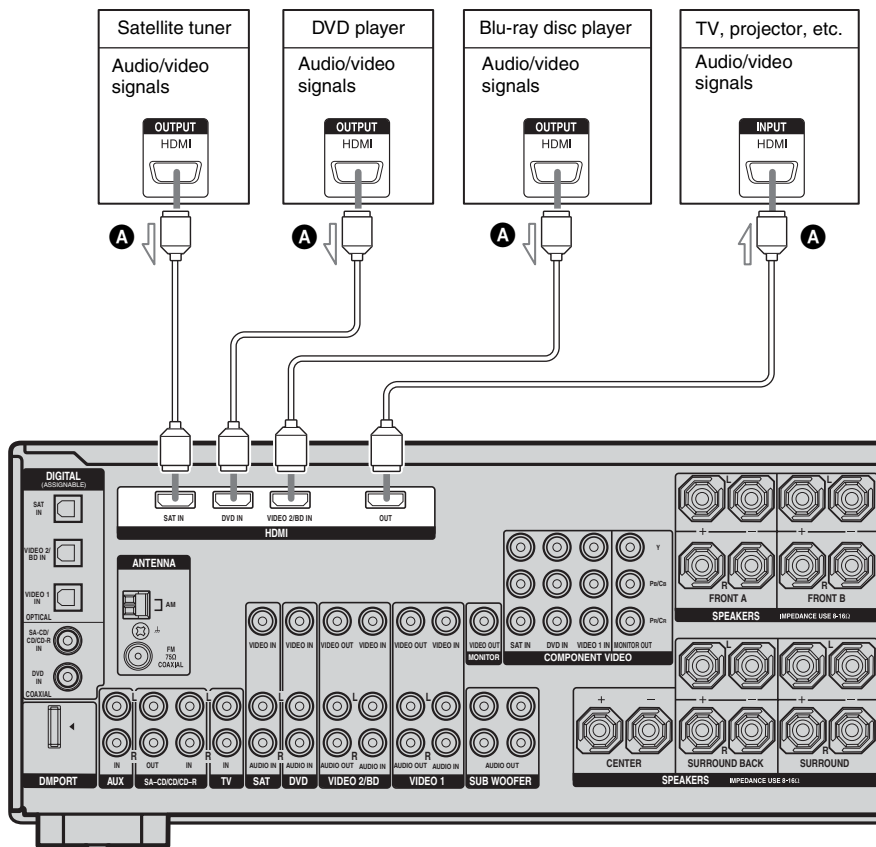

- A** HDMI cable (not supplied)
We recommend that you use a Sony HDMI cable.

If you connect a Blu-ray disc player

- Be sure to change the factory setting of the VIDEO 2 input button on the remote so that you can use the button to control your Blu-ray disc player. For details, see “Programming the remote” (page 78).
- You can also rename the VIDEO 2 input so that it can be displayed on the receiver’s display. For details, see “Naming inputs” (page 76).

Notes on HDMI connections

- Use a HDMI cable with the HDMI logo (made by Sony).
- An audio signal input to the HDMI IN jack is output from the SPEAKERS jacks and HDMI OUT jack. It is not output from any other audio jacks.
- Video signals input to the HDMI IN jack can only be output from the HDMI OUT jack. The video input signals cannot be output from the VIDEO OUT jacks or MONITOR OUT jacks.
- When you want to listen to the sound from the TV speaker, set “AUDIO” to “TV+AMP” in the VIDEO menu (page 54). If you cannot play back multi channel software, set to “AMP”. However, the sound will not output from the TV speaker.
- The multi/stereo area audio signals of a Super Audio CD are not output.
- Be sure to turn on the receiver when the video and audio of a playback component are being output to a TV via the receiver. If the power supply of the receiver is not turned on, neither video nor audio is transmitted.
- Audio signals (sampling frequency, bit length, etc.) transmitted from a HDMI jack may be suppressed by the connected component. Check the setup of the connected component if the image is poor or the sound does not come out of a component connected via the HDMI cable.
- Sound may be interrupted when the sampling frequency or the number of channels of audio output signals from the playback component is switched.
- When the connected component is not compatible with copyright protection technology (HDCP), the image and/or the sound from the HDMI OUT jack may be distorted or may not be output. In this case, check the specification of the connected component.
- Set the resolution of the image of the playback component to 720p or 1080i when you output 96 kHz multi channel sound over a HDMI connection.
- We do not recommend using a HDMI-DVI conversion cable. When you connect a HDMI-DVI conversion cable to a DVI-D component, the sound and/or the image may not be output.
- Refer to the operating instructions of each connected component for details.

Connecting a TV

The image from a visual component connected to this receiver can be displayed on a TV screen.

It is not necessary to connect all the cords. Connect audio and video cords according to the jacks of your components.

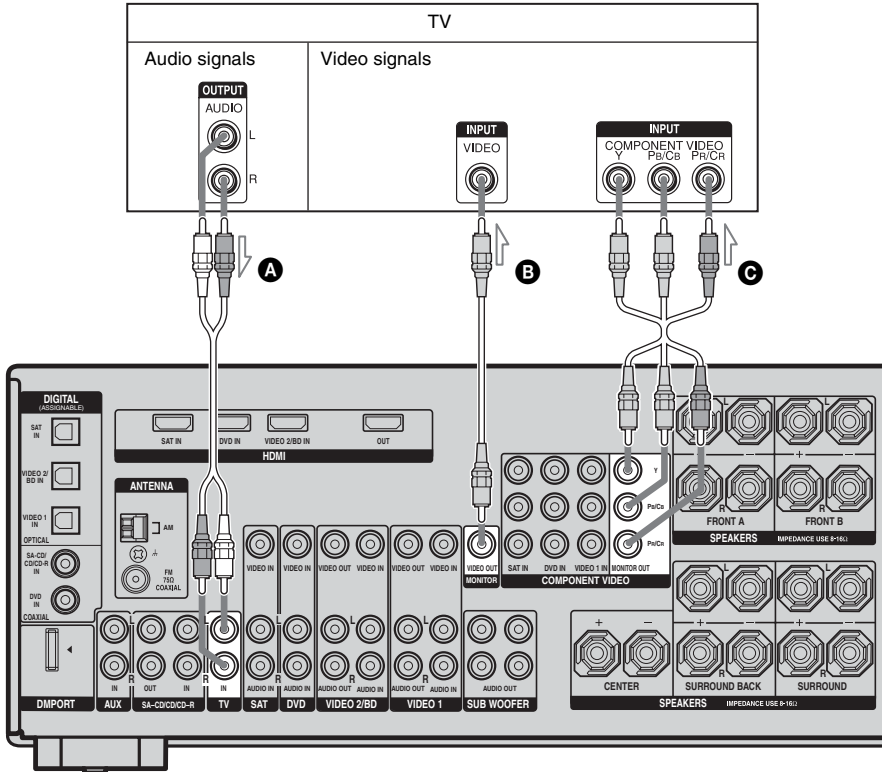

- A** Audio cord (not supplied)
- B** Video cord (not supplied)
- C** Component video cord (not supplied)

Notes

- Connect image display components such as a TV or a projector to the MONITOR OUT jack on the receiver.
- Be sure to turn on the receiver when the video and audio of a playback component are being output to a TV via the receiver. If the power supply of the receiver is not turned on, neither video nor audio is transmitted.

Tips

- You can watch the selected input image when you connect the MONITOR OUT jack to a TV.
- You can also display the amplifier menus and the sound field on the TV screen when you set the “OSD” to “OSD ON” in the VIDEO menu. Be sure to connect the HDMI OUT or MONITOR VIDEO OUT jack to your TV. If you connect only the COMPONENT VIDEO MONITOR OUT jacks to the TV, the on-screen display is not output.
- To output the TV sound from the speakers connected to the receiver, be sure to
 - connect the audio output jacks of the TV to the TV IN jacks of the receiver.
 - turn off or mute the TV’s volume.

Connecting a DVD player/DVD recorder

The following illustration shows how to connect a DVD player and DVD recorder. It is not necessary to connect all the cords. Connect audio and video cords according to the jacks of your components.

Note

To input multi channel digital audio from the DVD player, set the digital audio output setting on the DVD player. Refer to the operating instructions supplied with the DVD player.

Tip

All the digital audio jacks are compatible with 32 kHz, 44.1 kHz, 48 kHz, and 96 kHz sampling frequencies.

Connecting a DVD player

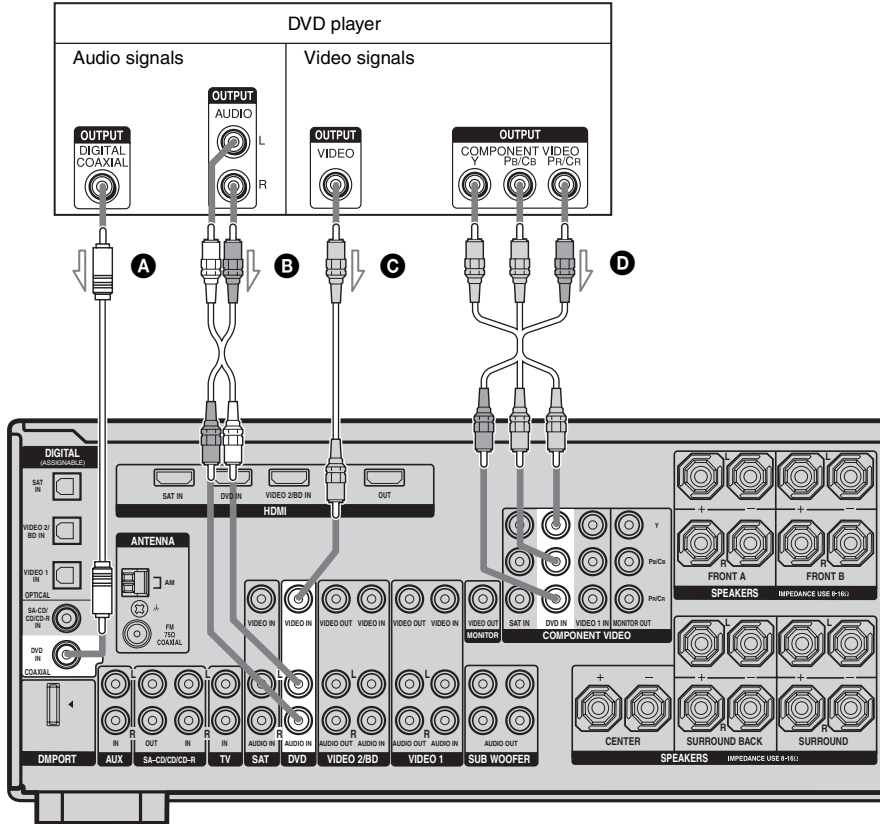

- A** Coaxial digital cord (not supplied)
- B** Audio cord (not supplied)
- C** Video cord (not supplied)
- D** Component video cord (not supplied)

Connecting a DVD recorder

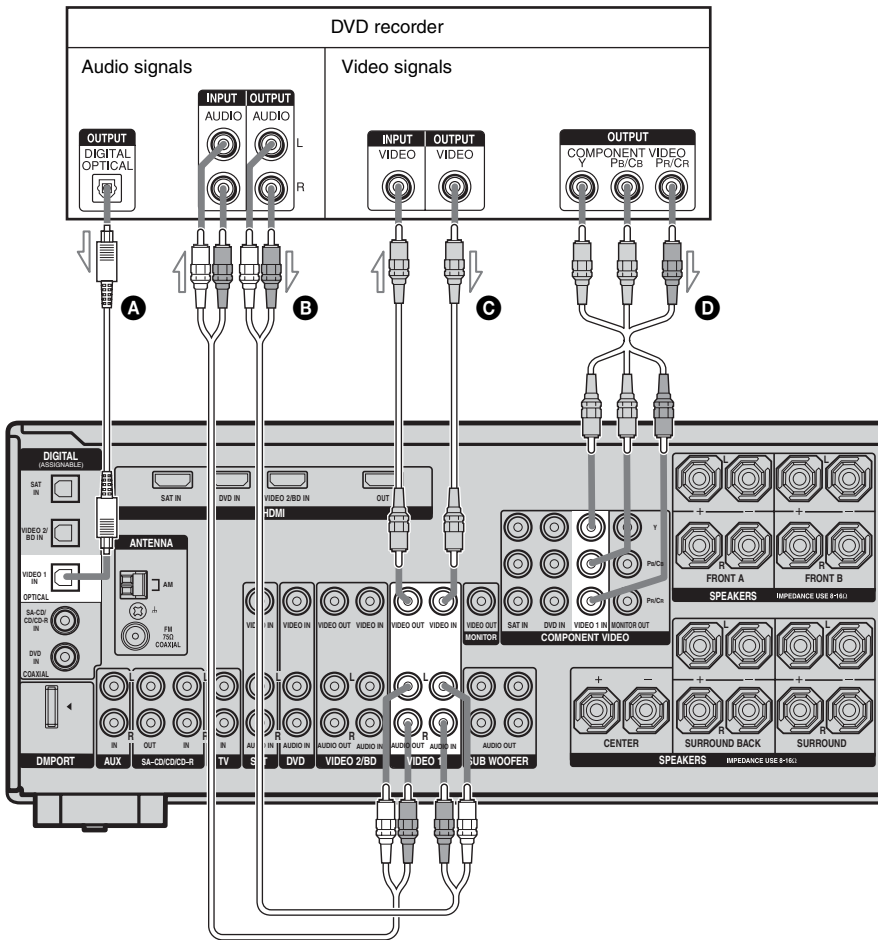

- A** Optical digital cord (not supplied)
- B** Audio cord (not supplied)
- C** Video cord (not supplied)
- D** Component video cord (not supplied)

Notes

- Be sure to change the factory setting of the VIDEO 1 input button on the remote so that you can use the button to control your DVD recorder. For details, see “Programming the remote” (page 78).
- You can also rename the VIDEO 1 input so that it can be displayed on the receiver’s display. For details, see “Naming inputs” (page 76).
- When connecting optical digital cords, insert the plugs straight in until they click into place.
- Do not bend or tie optical digital cords.

Tip

All the digital audio jacks are compatible with 32 kHz, 44.1 kHz, 48 kHz, and 96 kHz sampling frequencies.

Connecting a satellite tuner/ set-top box

The following illustration shows how to connect a satellite tuner or set-top box. It is not necessary to connect all the cords. Connect audio and video cords according to the jacks of your components.

Notes

- When connecting optical digital cords, insert the plugs straight in until they click into place.
- Do not bend or tie optical digital cords.

Tip

All the digital audio jacks are compatible with 32 kHz, 44.1 kHz, 48 kHz, and 96 kHz sampling frequencies.

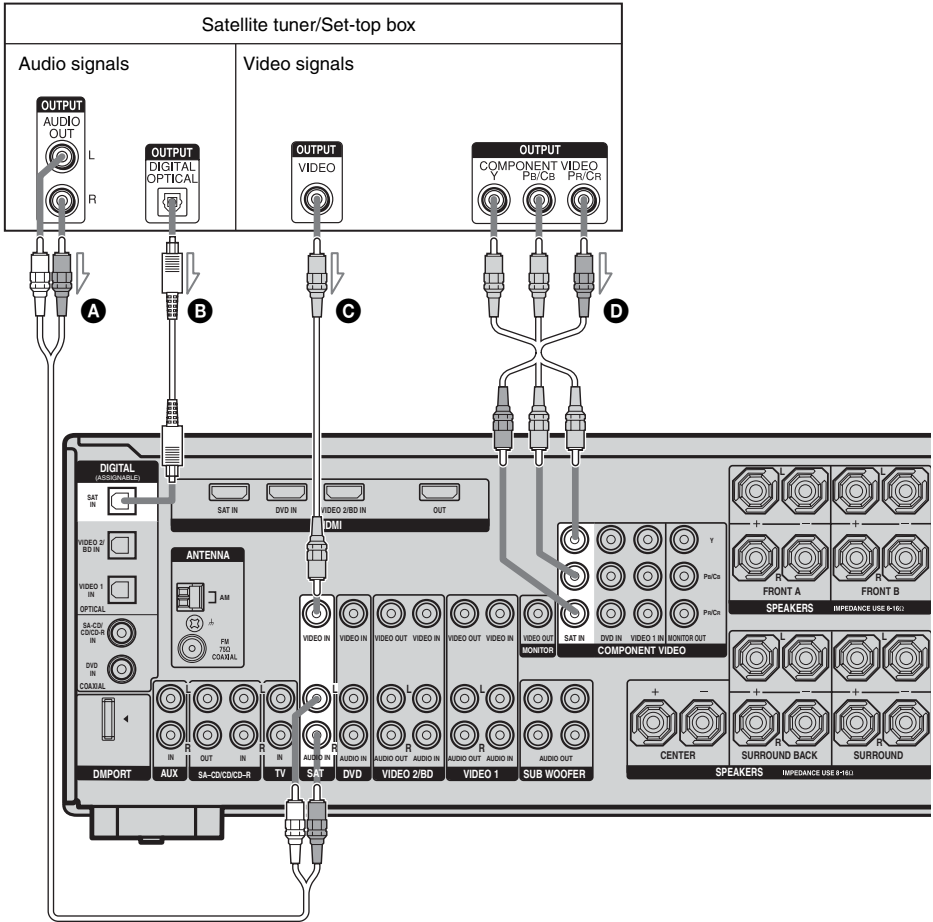

- A** Audio cord (not supplied)
- B** Optical digital cord (not supplied)
- C** Video cord (not supplied)
- D** Component video cord (not supplied)

Connecting components with analog video and audio jack

The following illustration shows how to connect a component which has analog jacks such as a VCR, etc.

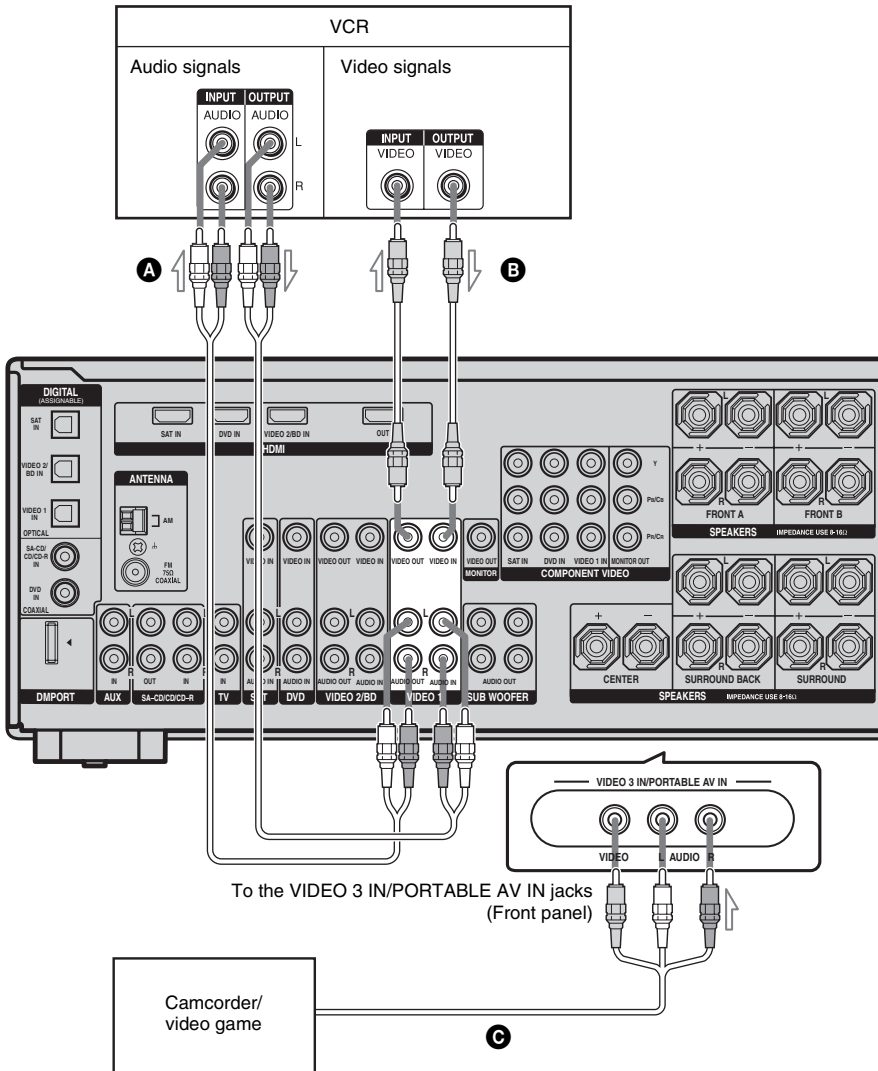

- A** Audio cord (not supplied)
- B** Video cord (not supplied)
- C** Audio/video cord (not supplied)

Function for conversion of video signals

This receiver is equipped with a function for converting video signals.

Video signals and component video signals can be output as HDMI video signals and this up-converted video signals can only be output from the HDMI OUT jack. Refer to the illustration that follows.

In the video input/output conversion table of the receiver

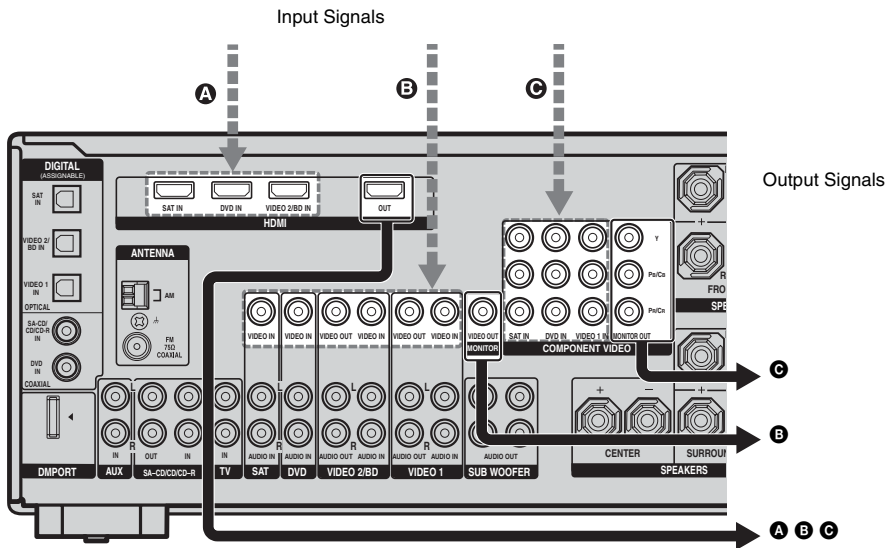

OUTPUT jack \ INPUT jack	HDMI OUT	COMPONENT VIDEO MONITOR OUT	MONITOR VIDEO OUT
HDMI IN A	△	X	X
VIDEO IN B	○	X	△
COMPONENT VIDEO IN C	○	△	X

○ : Video signals are up-converted and output through the video converter.

△ : The same type of signal as that of the input signal is output. Video signals are not converted.

X : Video signals are not output.

Notes on converting video signals

- When video signals from a VCR, etc., are converted on this receiver and then output to your TV, depending on the status of the video signal output, the image on the TV screen may appear distorted horizontally or no image may be output.
- HDMI video signals cannot be converted to component video signals and video signals.
- The up-converted video signals are output only from the HDMI OUT jack. They are not output from any other video jacks.
- When you play back a VCR with an image improvement circuit, such as TBC, the images may be distorted or may not be output. In this case, set the image improvement circuit function to off.

4: Connecting the antennas

Connect the supplied AM loop antenna and FM wire antenna.

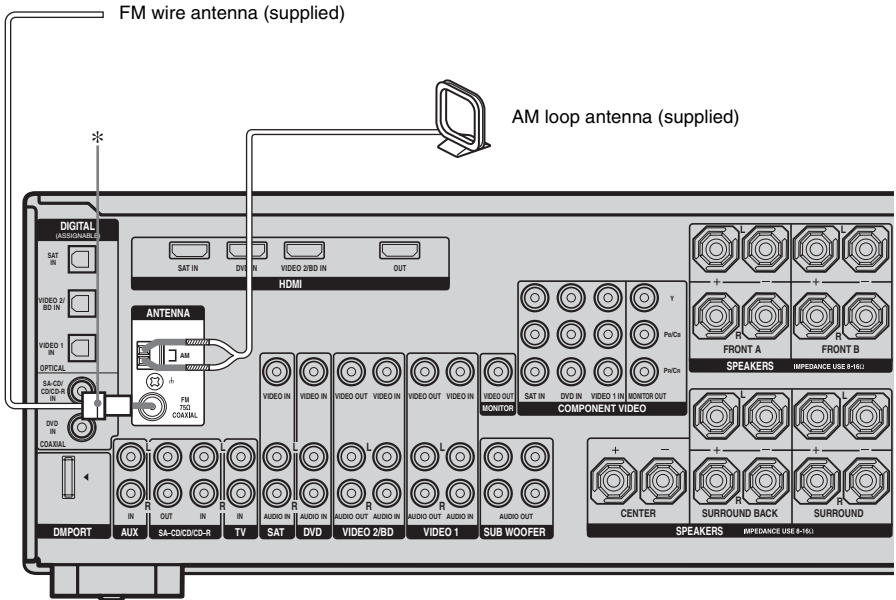

* The shape of the connector varies depending on the area code of this receiver.

Notes

- To prevent noise pickup, keep the AM loop antenna away from the receiver and other components.
- Be sure to fully extend the FM wire antenna.
- After connecting the FM wire antenna, keep it as horizontal as possible.

5: Preparing the receiver and the remote

Setting the voltage selector

If your receiver has a voltage selector on the rear panel, check that the voltage selector is set to the local power supply voltage. If not, use a screwdriver to set the selector to the correct position before connecting the AC power cord to a wall outlet.

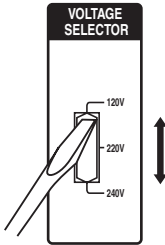

Notes

- The AC OUTLET on the rear of the receiver is a switched outlet, which supplies power to the connected component only while the receiver is turned on.
- Make sure that the total power consumption of the component connected to the receiver's AC OUTLET does not exceed the wattage stated on the rear panel. Do not connect high-wattage electrical home appliances such as electric irons, fans, or TVs to this outlet. This may cause a malfunction.

Connecting the AC power cord

Connect the AC power cord to a wall outlet.

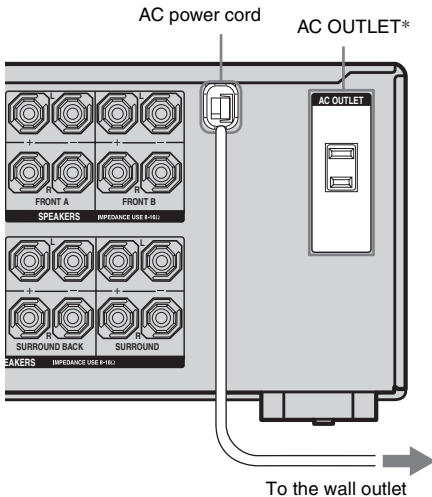

* Models of area code E2 only.

Performing initial setup operations

Before using the receiver for the first time, initialize the receiver by performing the following procedure. This procedure can also be used to return settings you have made to their factory defaults.

Be sure to use the buttons on the receiver for this operation.

1,2

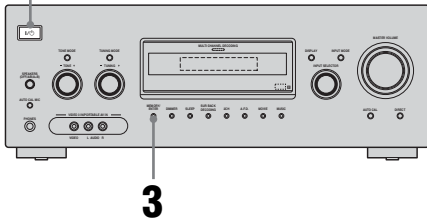

- 1 Press I/O to turn off the receiver.**
- 2 Hold down I/O for 5 seconds.**
“PUSH” and “ENTER” appears on the display alternately.
- 3 Press MEMORY/ENTER.**

After “CLEARING” appears on the display for a while, “CLEARED” appears.

The following items are reset to their factory settings.

- All settings in the LEVEL, EQ, SUR, TUNER, AUDIO, VIDEO, SYSTEM and A. CAL menus.
- The sound field memorized for each input and preset station.
- All sound field parameters.
- All preset stations.
- All index names for inputs and preset stations.
- MASTER VOLUME is set to “VOL MIN”.
- Input is set to “DVD”.

Inserting batteries into the remote

Insert two R6 (size-AA) batteries in the RM-AAP017 remote commander.

Observe the correct polarity when installing batteries.

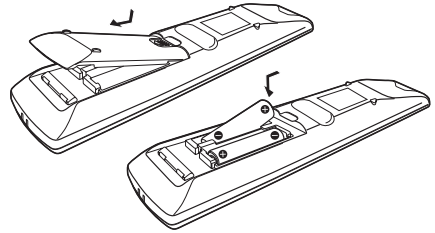

Notes

- Do not leave the remote in an extremely hot or humid place.
- Do not use a new battery with old ones.
- Do not mix alkaline batteries and other kinds of batteries.
- Do not expose the remote sensor to direct sunlight or lighting apparatuses. Doing so may cause a malfunction.
- If you do not intend to use the remote for an extended period of time, remove the batteries to avoid possible damage from battery leakage and corrosion.
- When you replace the batteries, the programmed remote codes may be cleared. If this happens, program the remote codes again (page 78).

Tip

Under normal conditions, the batteries should last for about 3 months. When the remote no longer operates the receiver, replace all the batteries with new ones.

6: Selecting the speaker system

You can select the front speakers you want to drive.

Be sure to use the buttons on the receiver for this operation.

SPEAKERS (OFF/A/B/A+B)

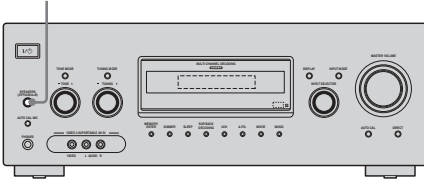

Press SPEAKERS (OFF/A/B/A+B) repeatedly to select the front speaker system you want to drive.

To select	Light up
The speakers connected to the SPEAKERS FRONT A terminals	SP A
The speakers connected to the SPEAKERS FRONT B terminals	SP B
The speakers connected to both the SPEAKERS FRONT A and B terminals (parallel connection)	SP A and SP B

To turn off the speaker output

Press SPEAKERS (OFF/A/B/A+B) repeatedly until the “SP A” and “SP B” indicators on the display do not light up.

Note

You cannot switch the front speaker system by pressing SPEAKERS (OFF/A/B/A+B) when the headphones are connected.

7: Calibrating the appropriate settings automatically (AUTO CALIBRATION)

This receiver is equipped with DCAC (Digital Cinema Auto Calibration) Technology which allows you to perform automatic calibration as follows:

- Check the connection between each speaker and the receiver.
 - Adjust the speaker level.
 - Measure the distance of each speaker to your listening position.
 - Measure the speaker polarity.
 - Measure the speaker size.
 - Measure the frequency characteristics.*
- * DTS 96/24 signals are always played back as 48 kHz when you correct signals.
- The measurement result is not utilized for signals with a sampling frequency of more than 96 kHz.

The DCAC is designed to obtain proper sound balance in your room. However, you can adjust the speaker levels and balance manually according to your preference. For details, see “8: Adjusting the speaker levels and balance (TEST TONE)” (page 39).

Before you perform Auto Calibration

Before you perform the Auto Calibration, set up and connect the speakers (page 14, 15).

- The AUTO CAL MIC jack is used for the supplied optimizer microphone only. Do not connect other microphones to this jack. Doing so may damage the receiver and the microphone.
- During the calibration, the sound that comes out of the speakers is very loud. Pay attention to the presence of children or to the effect on your neighborhood.
- Perform the Auto Calibration in a quiet environment to avoid the effect of noise and get a more accurate measurement.
- If there are any obstacles in the path between the optimizer microphone and the speakers, the calibration cannot be performed correctly. Remove any obstacles from the measurement area to avoid measurement error.

Note

The Auto Calibration function does not work in the following cases.

- ANALOG DIRECT is selected.
- Headphones are connected.

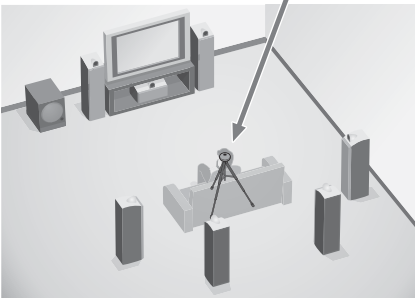
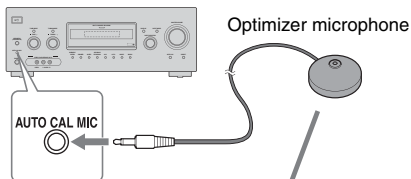

1 Connect the supplied optimizer microphone to the AUTO CAL MIC jack.

2 Set up the optimizer microphone.

Place the optimizer microphone at your listening position. Use a stool or tripod so that the optimizer microphone remains at the same height as your ears.

On setting up the active sub woofer

- When a sub woofer is connected, turn on the sub woofer and turn up the volume beforehand. Turn the VOLUME knob to just before the mid-point.
- If you connect a sub woofer with a crossover frequency function, set the value to the maximum.
- If you connect a sub woofer with an auto standby function, set this function to off (deactivated).

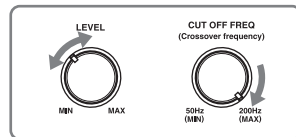

Note

Depending on the characteristics of the sub woofer you are using, the setup distance value may be further away from the actual position.

Performing Auto Calibration

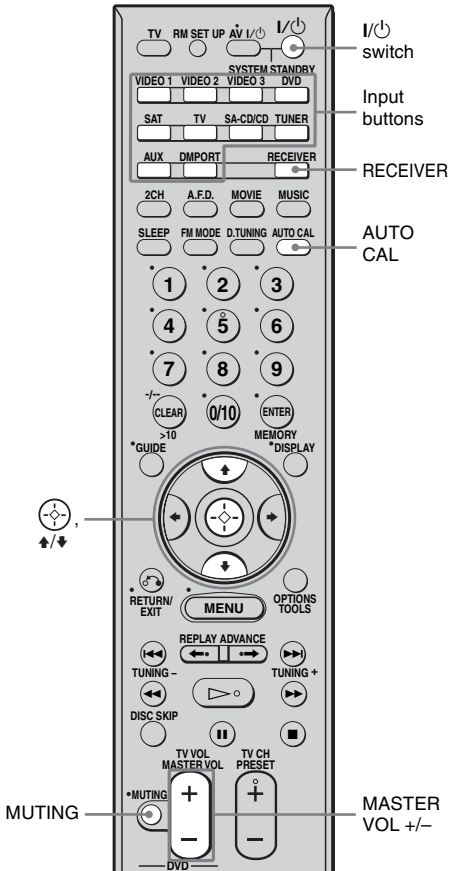

Press AUTO CAL.

Measurement starts in 5 seconds and the display changes as follows:

A. CAL [5] → A. CAL [4] → A. CAL [3] → A. CAL [2] → A. CAL [1]

The measurement process will take approximately 30 seconds to complete. The table below shows the display when measurement starts.

Measurement for	Display
Speaker existence	TONE
Speaker gain, distance, frequency response	T.S.P.
Sub woofer gain and distance	WOOFER

Note

You cannot measure the speaker height of the surround speakers and the surround back speakers. Set this value using the “SUR POS.” parameter in the SYSTEM menu (page 58).

Tip

The measurements may not be performed correctly or Auto Calibration cannot be performed when special speakers, such as dipole speakers are used.

To cancel Auto Calibration

The Auto Calibration function will be canceled when you do the following during the measurement process:

- Press I/⏻, input buttons or MUTING.
- Press SPEAKERS (OFF/A/B/A+B) on the receiver.
- Change the volume level.
- Press AUTO CAL again.
- Connect the headphones.

Confirming/saving the measurement results

1 Confirm the measurement result.

When the measurement ends, a beep sounds and the measurement result appears on the display.

Measurement result	Display	Explanation
When the measurement process completes properly	SAVE	Proceed to step 2.
When the measurement process fails	ERROR XXXX	See "When error codes appear" (page 36).

2 Press RECEIVER and then press \uparrow/\downarrow repeatedly to select the item. Then, press .

Item	Explanation
RETRY	Performs the Auto Calibration again.
SAVE	Saves the measurement results and exits the setting process.
WARN CHK	Displays warning concerning the measurement results. See "When you select "WARN CHK"" (page 37).
PHASE	Displays the phase of each speaker (in phase/out of phase). See "When you select "PHASE"" (page 37).
DISTANCE	Displays the measurement result for speaker distance.
LEVEL	Displays the measurement result for speaker level.
EXIT	Exits the setting process without saving the measurement results.

3 Save the measurement result.

Select "SAVE" in step 2.

The measurement results are saved and you can select the calibration type in the A. CAL menu.

For details on calibration type, see page 38.

Tip

The size of a speaker (LARGE/SMALL) is determined by the low frequency characteristics. The measurement results may vary, depending on the position of the optimizer microphone and speakers, and the shape of the room. It is recommended that you follow the measurement results. However, you can change those settings in the SYSTEM menu (page 47). Save the measurement results first, then try to change the settings if you want.

When error codes appear

Try the remedies and perform the Auto Calibration again.



Error code	Cause and remedies
ERROR 31	The SPEAKERS (OFF/A/B/A+B) is set to off. Set it to others and perform the Auto Calibration again.
ERROR 32	None of the speakers were detected. Make sure that the optimizer microphone is connected properly and perform the Auto Calibration again. If the optimizer microphone is connected properly but the error code appears, the optimizer microphone cable may be damaged or improperly connected.
ERROR F 33	<ul style="list-style-type: none">• None of the front speakers are connected or only one front speaker is connected.• The optimizer microphone is not connected.

Error code	Cause and remedies
ERROR SR 33	<ul style="list-style-type: none"> • Either the left or right surround speakers is not connected. • Surround back speakers are connected even though surround speakers are not connected. Connect the surround speakers to the SPEAKERS SURROUND terminals.
ERROR SB 33	The surround back speaker is connected only to the SPEAKERS SURROUND BACK R terminals. When you connect only one surround back speaker, connect it to the SPEAKERS SURROUND BACK L terminals.

• CODE 31

- 1 Press RECEIVER.
The RECEIVER indicator lights up and receiver operation is activated.
- 2 Press .
- 3 Perform the Auto Calibration again (page 35).

• CODE 32, 33

- 1 Press RECEIVER.
The RECEIVER indicator lights up and receiver operation is activated.
- 2 Press .
- 3 Press  again.
- 4 Perform the Auto Calibration again (page 35).

When you select “WARN CHK”



If a warning on the measurement result is present, detailed information is displayed.

Press  to return to step 2 of “Confirming/saving the measurement results”.

Warning code	Explanation
WARN 40	The Auto Calibration has completed. However, the noise level is high. You may be able to perform the Auto Calibration properly if you try it again, even though the measurement cannot be performed in all environments. Try to perform the Auto Calibration in a quiet environment.
WARN 41	The sound input from the optimizer microphone is out of range. It is louder than the loudest sound that can be measured. Try to perform the Auto Calibration when the environment is quiet enough to allow proper measurement.
WARN 42	The volume of the receiver is out of range. Try to perform the Auto Calibration when the environment is quiet enough to allow proper measurement.
WARN 43	The distance and position of a sub woofer cannot be detected. This may be caused by noise. Try to perform the Auto Calibration in a quiet environment.
NO WARN	There is no warning information.

When you select “PHASE”

You can check the phase of each speaker (in phase/out of phase).

Press  repeatedly to select a speaker, then press  to return to step 2 in “Confirming/saving the measurement results”.

continued

Display	Explanation
■ ■ ■ * IN	The speaker is in phase.
■ ■ ■ * OUT	The speaker is out of phase. The “+” and “-” terminals of the speaker may be connected the other way around. However, depending on the speakers, “■ ■ ■ OUT” appears on the display even though the speakers are connected properly. This is because of the speakers’ specifications. In this case, you can continue to use the receiver.

* ■ ■ ■ represent a speaker channel.

FL	Front Left
FR	Front Right
C	Center
SL	Surround Left
SR	Surround Right
SBL	Surround Back Left
SBR	Surround Back Right
SW	Sub woofer

Tip

Depending on the position of the sub woofer, the measurement results for polarity may vary. However, there will be no problems even if you continue to use the receiver with that value.

A. CAL menu parameters

Select “8-A. CAL” in the amplifier menus. For details on adjusting the parameters, see “Navigating through menus” (page 44) and “Overview of the menus” (page 45).

■ AUTO CAL (Auto Calibration on/off)

- A.CAL NO
The Auto Calibration function is turned off.
- A.CAL YES
The Auto Calibration function is turned on.
To start Auto Calibration, press .

■ CAL TYPE (Calibration type)*

- ENGINEER
Sets the frequency characteristics to a set that matches that of the Sony listening room standard.
- FLAT
Makes the measurement of frequency from each speaker flat.
- FRT REF
Adjusts the characteristics of all speakers to match the characteristics of the front speaker.

■ CAL LOAD (Preset measurement loading)*

- LOAD NO
Select this when you do not want to load the saved Auto Calibration result.
- LOAD YES
Select this when you want to load the saved Auto Calibration result.

* You can select this parameter only when you have performed the Auto Calibration and saved the settings.

8: Adjusting the speaker levels and balance (TEST TONE)

You can adjust the speaker levels and balance while listening to the test tone from your listening position.

Tip

The receiver employs a test tone with a frequency centered at 800 Hz.

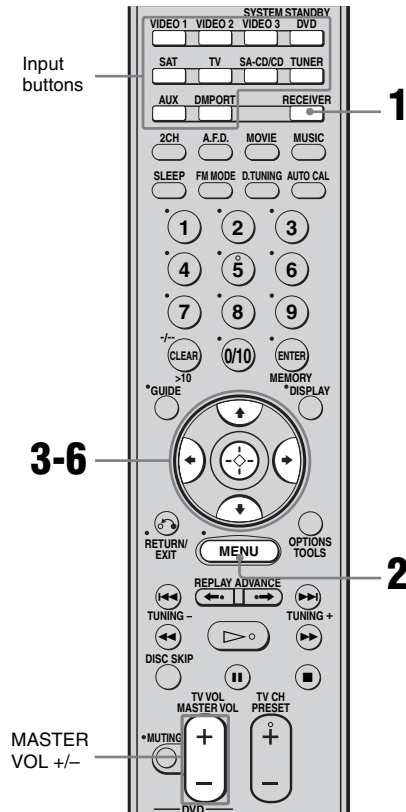

1 Press RECEIVER.

The RECEIVER indicator lights up and receiver operation is activated.

2 Press MENU.

“1-LEVEL” appears on the display.

3 Press \odot or \rightarrow to enter the menu.

4 Press \uparrow/\downarrow repeatedly to select “T. TONE”.

5 Press \odot or \rightarrow to enter the parameter.

6 Press \uparrow/\downarrow repeatedly to select “T. TONE Y”.

The test tone is output from each speaker in sequence as follows:

Front left \rightarrow Center \rightarrow Front right \rightarrow
Surround right \rightarrow Surround back right*
 \rightarrow Surround back left* \rightarrow Surround left
 \rightarrow Sub woofer

* You will only hear the test tone from the
– surround back left and right speakers when surround back speakers are set to “DUAL”.
– surround back left speaker when surround back speakers are set to “SINGLE”.

7 Adjust the speaker levels and balance using the LEVEL menu so that the level of the test tone sounds the same from each speaker.

For details, see “Adjusting the level (LEVEL menu)” (page 49).

Tips

- To adjust the level of all speakers at the same time, press MASTER VOL +/- . You can also use MASTER VOLUME on the receiver.
- The adjusted value are shown on the display during adjustment.

8 Repeat steps 1 to 6 to select “T. TONE N”.

You can also press any input buttons. The test tone turns off.

continued

When a test tone is not output from the speakers

- The speaker cords may not be connected securely.
- The speaker cords may have the short-circuit problem.

Note

The test tone does not work when ANALOG DIRECT is selected.

Playback

Selecting a component



- 1 Press one of the input buttons to select the component you want.**

You can also use INPUT SELECTOR on the receiver.

The selected input appears on the display.

Selected input [Display]	Components that can be played back
VIDEO 1 [VIDEO 1]	VCR, etc., connected to the VIDEO 1 jack
VIDEO 2 [VIDEO 2/BD]*	Blu-ray disc player, etc., connected to the VIDEO 2/BD jack
VIDEO 3 [VIDEO 3/ PORTABLE AV]*	Camcorder, video game, etc., connected to the VIDEO 3 IN/PORTABLE AV IN jack
DVD [DVD]	DVD player, etc., connected to DVD jack
SAT [SAT]	Satellite tuner, set-top box, etc., connected to SAT jack
TV [TV]	TV, etc., connected to TV jack
SA-CD/CD [SA-CD/CD/ CD-R]*	Super Audio CD player, CD player, etc., connected to the SA-CD/CD/CD-R jack
TUNER [FM or AM band]	Built-in radio tuner
AUX [AUX]	Audio components connected to the AUX jack
DMPORT [DMPORT]	DIGITAL MEDIA PORT adapter connected to DMPORT jack

* “VIDEO 2/BD”, “VIDEO 3/PORTABLE AV” and “SA-CD/CD/CD-R” scroll across the display, then “VIDEO 2”, “VIDEO 3” and “SA-CD/CD” appear respectively.

2 Turn on the component and start playback.

3 Press MASTER VOL +/- to adjust the volume.

You can also use MASTER VOLUME on the receiver.

To mute the sound

Press MUTING.

The muting function will be canceled when you do the following.

- Press MUTING again.
- Increase the volume.
- Turn off the receiver.

To avoid damaging your speakers

Before you turn off the receiver, be sure to turn down the volume level.

Listening/Watching a component

Listening to a Super Audio CD/CD

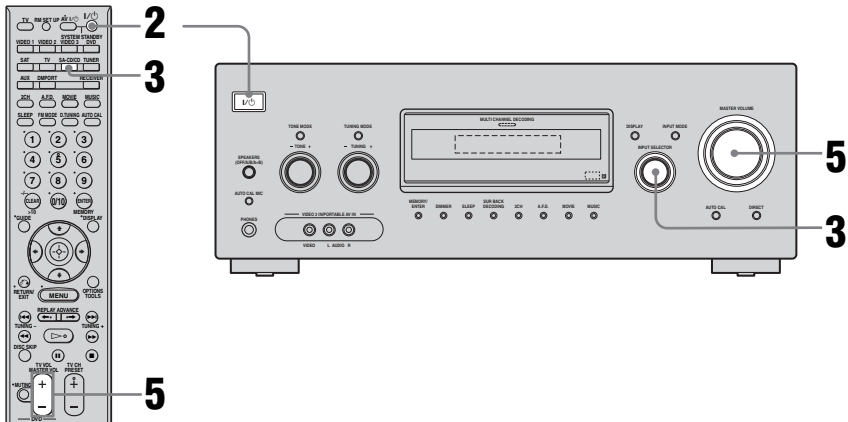

Notes

- The operation is described for a Sony Super Audio CD player.
- Refer to the operating instructions supplied with the Super Audio CD player or CD player.

Tips

- You can select the sound field to suit the music. Refer to page 61 for details.
Recommended sound fields:
Classical: HALL
Jazz: JAZZ
Live concert: CONCERT
- You can listen to the sound that was recorded in the 2 channel format from all speakers (multi channel). Refer to page 59 for details.

1 Turn on the Super Audio CD player or CD player, then place the disc on the tray.

2 Turn on the receiver.

3 Press SA-CD/CD.

You can also use INPUT SELECTOR on the receiver to select "SA-CD/CD/CD-R".

4 Play back the disc.

5 Adjust to a suitable volume.

6 After you have finished listening to the Super Audio CD/CD, eject the disc and turn off the receiver and Super Audio CD player or CD player.

Watching a DVD

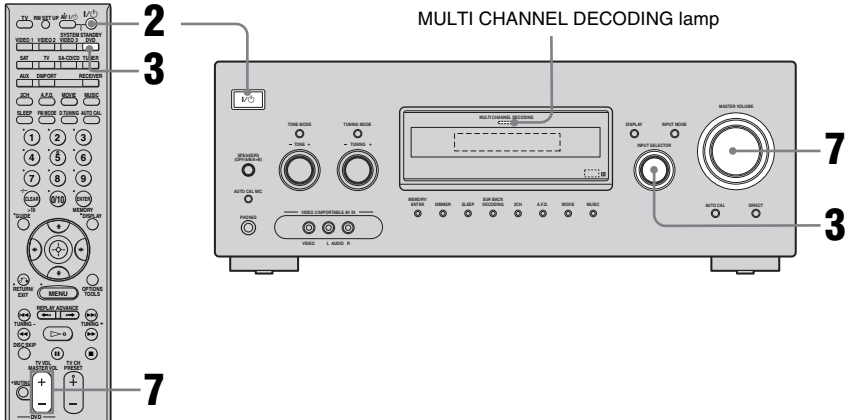

Notes

- Refer to the operating instructions supplied with the TV and DVD player.
- Check the following if you cannot listen to multi channel sound.
 - Be sure the audio source corresponds to the multi channel format (the MULTI CHANNEL DECODING lamp on the front panel lights up during playback).
 - Be sure this receiver is connected to the DVD player via a digital connection.
 - Be sure the digital audio output of the DVD player is set up properly.

Tips

- Select the audio format of the disc to be played back, if necessary.
- You can select the sound field to suit the movie or music. Refer to page 61 for details.
Recommended sound fields:
Movie: C.ST.EX
Music: CONCERT

1 Turn on the TV and DVD player.

2 Turn on the receiver.

3 Press DVD.

You can also use INPUT SELECTOR on the receiver to select “DVD”.

4 Switch the input of the TV so that an image of the DVD is displayed.

5 Set up the DVD player.

Refer to the “Quick Setup Guide” supplied with the receiver.

6 Play back the disc.

7 Adjust to a suitable volume.

8 After you have finished watching the DVD, eject the disc and turn off the receiver, TV and DVD player.

Amplifier Operations

Navigating through menus

By using the amplifier menus, you can make various adjustments to customize the receiver.

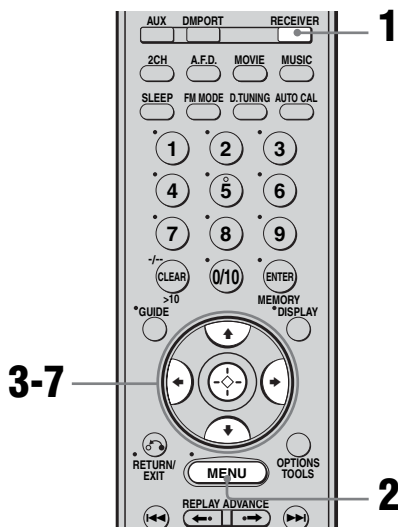

6 Press or to enter the parameter.

7 Press / repeatedly to select the setting you want.

The setting is entered automatically.

8 Repeat steps 3 to 7 when you want to make other settings.

To return to the previous display

Press .

To exit the menu

Press MENU.

However, if the RECEIVER indicator is light off, press RECEIVER and then press MENU.

Note

Some parameters and settings may appear dimmed on the display. This means that they are either unavailable or fixed and unchangeable.

Tip

You can display the amplifier menus on the TV screen by setting the “OSD” in VIDEO menu to “OSD ON”.

1 Press RECEIVER.

The RECEIVER indicator lights up and receiver operation is activated.

2 Press MENU.

“1-LEVEL” appears on the display.

3 Press / repeatedly to select the menu you want.

4 Press or to enter the menu.

5 Press / repeatedly to select the parameter you want to adjust.

Overview of the menus

The following options are available in each menu. For details on navigating through menus, see page 44.

Menu [Display]	Parameters [Display]	Settings	Initial setting
LEVEL [1-LEVEL] (page 49)	Test tone ^{a)} [T. TONE]	T. TONE Y, T. TONE N	T. TONE N
	Front speaker balance ^{a)} [FRT BAL]	BAL. L +1 to BAL. L +10, BALANCE, BAL. R +1 to BAL. R +10	BALANCE
	Center speaker level [CNT LVL]	CNT -10 dB to CNT +10 dB (1 dB step)	CNT 0 dB
	Surround left speaker level [SL LVL]	SUR L -10 dB to SUR L +10 dB (1 dB step)	SUR L 0 dB
	Surround right speaker level [SR LVL]	SUR R -10 dB to SUR R +10 dB (1 dB step)	SUR R 0 dB
	Surround back speaker level ^{b)} [SB LVL]	SB -10 dB to SB +10 dB (1 dB step)	SB 0 dB
	Surround back left speaker level ^{c)} [SBL LVL]	SBL -10 dB to SBL +10 dB (1 dB step)	SBL 0 dB
	Surround back right speaker level ^{c)} [SBR LVL]	SBR -10 dB to SBR +10 dB (1 dB step)	SBR 0 dB
	Sub woofer level [SW LVL]	SW -10 dB to SW +10 dB (1 dB step)	SW 0 dB
EQ [2-EQ] (page 50)	Dynamic range compressor ^{a)} [D. RANGE]	COMP. OFF, COMP. STD, COMP. MAX	COMP. OFF
	Equalizer on/off ^{a)} [EQ]	EQ OFF, EQ ON	EQ OFF
	Front speakers bass level [BASS LVL]	BASS -10 dB to BASS +10 dB (0.5 dB step)	BASS 0 dB
SUR [3-SUR] (page 50)	Front speakers treble level [TRE LVL]	TRE -10 dB to TRE +10 dB (0.5 dB step)	TRE 0 dB
	Sound field selection ^{a)} [S.F. SELCT]	2CH ST., A.F.D. AUTO, DOLBY PL, PLII MV, PLII MS, PLII GM, PLIIX MV, PLIIX MS, PLIIX GM, NEO6 CIN, NEO6 MUS, MULTI ST., C.ST.EX A, C.ST.EX B, C.ST.EX C, PORTABLE, HALL, JAZZ, CONCERT	A.F.D. AUTO for: VIDEO 1, 2, 3, DVD, SAT; 2CH ST. for: TV, SA-CD/ CD, TUNER, AUX, DMPORT
	Surround back decoding mode ^{a)} [SB DEC]	SB OFF, SB AUTO, SB ON	SB AUTO
	Effect level ^{a)} [EFFECT]	EFCT. MIN, EFCT. STD, EFCT. MAX	EFCT. STD

Menu [Display]	Parameters [Display]	Settings	Initial setting
TUNER [4-TUNER] (page 52)	FM station receiving mode ^{a)} [FM MODE]	FM AUTO, FM MONO	FM AUTO
	Naming preset stations ^{a)} [NAME IN]		
AUDIO [5-AUDIO] (page 53)	Digital audio input decoding priority ^{a)} [DEC. PRI.]	DEC. AUTO, DEC. PCM	DEC. AUTO for: VIDEO 1, 2, 3, DVD, SAT, TV; DEC. PCM for: SA-CD/CD
	Digital broadcast language selection ^{a)} [DUAL]	DUAL M/S, DUAL M, DUAL S, DUAL M+S	DUAL M
	Synchronizes audio with video output ^{a)} [A.V. SYNC.]	A.V.SYNC. 0 to A.V.SYNC. 20	A.V.SYNC. 0
	Digital audio input assignment [D. ASSIGN]	For details, see page 72.	
	Naming inputs ^{a)} [NAME IN]		
VIDEO [6-VIDEO] (page 54)	On-Screen Display on/off ^{a)} [OSD]	OSD ON, OSD OFF	OSD OFF
	DIGITAL MEDIA PORT video assign ^{a)} [DMPORT V.]	-NONE, -VIDEO 1, -VIDEO 2, -VIDEO 3, -DVD, -SAT	-NONE
	HDMI AUDIO ^{a)d)} [AUDIO]	AMP, TV+AMP	AMP
	HDMI CONTROL ^{a)d)} [CONTROL]	CTRL ON, CTRL OFF	CTRL OFF
	Color TV type selection ^{a)g)} [COL SYS]	COL NTSC, COL PAL	COL PAL
	Naming inputs ^{a)} [NAME IN]		

Menu [Display]	Parameters [Display]	Settings	Initial setting
SYSTEM [7-SYSTEM] (page 55)	Sub woofer ^{a)} [SW SPK]	YES, NO	YES
	Front speakers ^{a)} [FRT SPK]	LARGE, SMALL	LARGE
	Center speaker ^{a)} [CNT SPK]	LARGE, SMALL, NO	LARGE
	Surround speakers ^{a)} [SUR SPK]	LARGE, SMALL, NO	LARGE
	Surround back speakers ^{a)} [SB SPK]	DUAL, SINGLE, NO	DUAL
	Front left speaker distance ^{a)c)e)} [FL DIST.]	DIST. 1.0 m to DIST. 7.0 m (0.1 m step)	DIST. 3.0 m
	Front right speaker distance ^{a)c)e)} [FR DIST.]	DIST. 1.0 m to DIST. 7.0 m (0.1 m step)	DIST. 3.0 m
	Center speaker distance ^{a)c)e)} [CNT DIST.]	DIST. 1.0 m to DIST. 7.0 m (0.1 m step)	DIST. 3.0 m
	Surround left speaker distance ^{a)c)e)} [SL DIST.]	DIST. 1.0 m to DIST. 7.0 m (0.1 m step)	DIST. 3.0 m
	Surround right speaker distance ^{a)c)e)} [SR DIST.]	DIST. 1.0 m to DIST. 7.0 m (0.1 m step)	DIST. 3.0 m
	Surround back speaker distance ^{a)b)c)e)} [SB DIST.]	DIST. 1.0 m to DIST. 7.0 m (0.1 m step)	DIST. 3.0 m
	Surround back left speaker distance ^{a)c)e)} [SBL DIST.]	DIST. 1.0 m to DIST. 7.0 m (0.1 m step)	DIST. 3.0 m
	Surround back right speaker distance ^{a)c)e)} [SBR DIST.]	DIST. 1.0 m to DIST. 7.0 m (0.1 m step)	DIST. 3.0 m
	Sub woofer distance ^{a)c)e)} [SW DIST.]	DIST. 1.0 m to DIST. 7.0 m (0.1 m step)	DIST. 3.0 m
	Surround speaker position ^{a)} [SUR POS.]	SIDE/LO, SIDE/HI, BEHD/LO, BEHD/HI	SIDE/LO
	Speaker crossover frequency ^{a)f)} [CRS. FREQ]	CRS > 40 Hz to CRS > 160 Hz (10 Hz step)	CRS > 100 Hz
Brightness of the display ^{a)} [DIMMER]	0% dim, 40% dim, 70% dim	0% dim	

continued

Menu [Display]	Parameters [Display]	Settings	Initial setting
A. CAL [8-A. CAL] (page 38)	Auto Calibration on/off ^{a)} [AUTO CAL]	A.CAL YES, A.CAL NO	A.CAL NO
	Calibration type ^{a)} [CAL TYPE]	ENGINEER, FLAT, FRT REF	FLAT
	Preset measurement loading ^{a)} [CAL LOAD]	LOAD NO, LOAD YES	LOAD NO

^{a)}For details, refer to the page in the parentheses.

^{b)}You can only select this parameter when the surround back speakers are set to “SINGLE”.

^{c)}You can only select this parameter when the surround back speakers are set to “DUAL”.

^{d)}When you select this parameter, the “HDMI” flashes on the display.

^{e)}When you set “CAL LOAD” in A. CAL menu to “LOAD YES”, the setting is displayed as ■.■ m and you can adjust the setting in 0.01 meter increment.

^{f)}This parameter is only available when at least one speaker is set to “SMALL” and “CAL LOAD” is set to “LOAD NO” in A. CAL menu.

^{g)}Models of area code CEL, CEK, E2 only.

Adjusting the level

(LEVEL menu)

You can use the LEVEL menu to adjust the balance and level of each speaker. These settings are applied to all sound fields. Select “1-LEVEL” in the amplifier menus. For details on adjusting the parameters, see “Navigating through menus” (page 44) and “Overview of the menus” (page 45).

LEVEL menu parameters

■ T. TONE (Test tone)

Lets you adjust the speaker levels and balance while listening to the test tone from your listening position. For details, see “8: Adjusting the speaker levels and balance (TEST TONE)” (page 39).

■ FRT BAL (Front speaker balance)

Lets you adjust the balance between front left and right speakers.

■ CNT LVL (Center speaker level)

■ SL LVL (Surround left speaker level)

■ SR LVL (Surround right speaker level)

■ SB LVL (Surround back speaker level)^{a)}

■ SBL LVL (Surround back left speaker level)^{b)}

■ SBR LVL (Surround back right speaker level)^{b)}

■ SW LVL (Sub woofer level)

a) You can only select this parameter when the surround back speakers are set to “SINGLE” in SYSTEM menu.

b) You can only select this parameter when the surround back speakers are set to “DUAL” in SYSTEM menu.

■ D. RANGE (Dynamic range compressor)

Lets you compress the dynamic range of the sound track. This may be useful when you want to watch movies at low volumes late at night. Dynamic range compression is possible with Dolby Digital sources only.

- COMP. OFF

The dynamic range is not compressed.

- COMP. STD

The dynamic range is compressed as intended by the recording engineer.

- COMP. MAX

The dynamic range is compressed dramatically.

Tip

Dynamic range compressor lets you compress the dynamic range of the soundtrack based on the dynamic range information included in the Dolby Digital signal.

“COMP. STD” is the standard setting, but it only enacts light compression. Therefore, we recommend using the “COMP. MAX” setting. This greatly compresses the dynamic range and lets you view movies late at night at low volumes. Unlike analog limiters, the levels are predetermined and provide a very natural compression.

Adjusting the equalizer (EQ menu)

You can use the EQ menu to adjust the tonal quality (bass/treble level) of the front speakers.

Select “2-EQ” in the amplifier menus. For details on adjusting the parameters, see “Navigating through menus” (page 44) and “Overview of the menus” (page 45).

EQ menu parameters

■ EQ (Equalizer on/off)

- EQ ON
The equalizer is turned on.
- EQ OFF
The equalizer is turned off.

■ BASS LVL (Front speakers bass level)*

■ TRE LVL (Front speakers treble level)*

* You can also adjust the front speaker bass and treble level with TONE MODE and TONE +/- on the receiver (page 4).

Settings for the surround sound (SUR menu)

You can use the SUR menu to select the sound field you want for your listening pleasure.

Select “3-SUR” in the amplifier menus. For details on adjusting the parameters, see “Navigating through menus” (page 44) and “Overview of the menus” (page 45).

SUR menu parameters

■ S.F. SELCT (Sound field selection)

Lets you select the sound field you want. For details, see “Enjoying Surround Sound” (page 59).

Note

The receiver lets you apply the last selected sound field to an input whenever it is selected (Sound Field Link). For example, if you select “HALL” for the SA-CD/CD input, then change to a different input and then return to SA-CD/CD, “HALL” will automatically be applied again.

■ SB DEC (Surround back decoding mode)

Lets you select the surround back decoding mode. For details, see “Using the surround back decoding mode” (page 51).

■ EFFECT (Effect level)

Lets you adjust the “presence” of the surround effect for sound fields selected with the MOVIE or MUSIC button and for “HP THEA” sound field.

- EFCT. MIN
The surround effect is minimum.
- EFCT. STD
The surround effect is standard.
- EFCT. MAX
The surround effect is maximum.

Using the surround back decoding mode

(SUR BACK DECODING)

By decoding the surround back signal of DVD software (etc.) recorded in Dolby Digital Surround EX, DTS-ES Matrix, DTS-ES Discrete 6.1, etc., format, you can enjoy the surround sound intended by the filmmakers. Select the surround back decoding mode using “SB DEC” in the SUR menu (page 45). You can also use SUR BACK DECODING on the receiver.

Types of the surround back decoding functions

■ SB AUTO

When the input stream contains the 6.1 channel decode flag^{a)}, the appropriate decoding is performed on the surround back signal.

Input stream	Output channel	Surround back decoding
Dolby Digital 5.1	5.1 ^{e)}	—
Dolby Digital Surround EX ^{b)}	6.1 ^{e)}	Matrix decoder that conforms to Dolby Digital EX
DTS 5.1	5.1 ^{e)}	—
DTS-ES Matrix 6.1 ^{c)}	6.1 ^{e)}	DTS Matrix decoding
DTS-ES Discrete 6.1 ^{d)}	6.1 ^{e)}	DTS Discrete decoding
Dolby Digital Surround EX ^{b)}	7.1	Matrix decoder that conforms to Dolby Pro Logic IIx
DTS-ES Matrix 6.1 ^{c)}	7.1	DTS Matrix decoding
DTS-ES Discrete 6.1 ^{d)}	7.1	DTS Discrete decoding

■ SB ON

To decode the surround back signal regardless of the 6.1 channel decode flag^{a)}, Dolby Digital EX is applied when the output channel is 6.1 channel.

Input stream	Output channel	Surround back decoding
Dolby Digital 5.1	6.1 ^{e)}	Matrix decoder that conforms to Dolby Digital EX
Dolby Digital Surround EX ^{b)}	6.1 ^{e)}	Matrix decoder that conforms to Dolby Digital EX
DTS 5.1	6.1 ^{e)}	Matrix decoder that conforms to Dolby Digital EX
DTS-ES Matrix 6.1 ^{c)}	6.1 ^{e)}	Matrix decoder that conforms to Dolby Digital EX
DTS-ES Discrete 6.1 ^{d)}	6.1 ^{e)}	Matrix decoder that conforms to Dolby Digital EX
Dolby Digital 5.1	7.1	Matrix decoder that conforms to Dolby Pro Logic IIx
Dolby Digital Surround EX ^{b)}	7.1	Matrix decoder that conforms to Dolby Pro Logic IIx
DTS 5.1	7.1	Matrix decoder that conforms to Dolby Digital EX
DTS-ES Matrix 6.1 ^{c)}	7.1	Matrix decoder that conforms to Dolby Digital EX
DTS-ES Discrete 6.1 ^{d)}	7.1	Matrix decoder that conforms to Dolby Digital EX

■ SB OFF

Surround back decoding is not performed.

- a) A 6.1 channel decode flag is information recorded in software such as DVDs.
- b) A Dolby Digital DVD that includes a Surround EX flag. The Dolby Corporation web page can help you distinguish Surround EX films.
- c) Software encoded with a flag to denote it has both DTS-ES Matrix and 5.1 channel signals.
- d) Software encoded with both 5.1 channel signals and an extension stream designed for returning those signals to 6.1 discrete channels. Discrete 6.1 channel signals are DVD specific signals not used in movie theaters.
- e) When two surround back speakers are connected, the output channel will be 7.1 channel.

Notes

- There may be no sound from the surround back speaker in Dolby Digital EX mode. Some discs have no Dolby Digital Surround EX flag even though the packages have Dolby Digital EX logos. In this case, select “SB ON”.
- You can select the surround back decoding mode only when A.F.D. mode is selected. However, this function is canceled when Dolby Pro Logic IIx is selected.

Settings for the tuner (TUNER menu)

You can use the TUNER menu to set the FM station receiving mode and to name preset stations.

Select “4-TUNER” in the amplifier menus. For details on adjusting the parameters, see “Navigating through menus” (page 44) and “Overview of the menus” (page 45).

TUNER menu parameters

■ FM MODE (FM station receiving mode)

- FM AUTO
This receiver will decode the signal as stereo signal when the radio station is broadcast in stereo.
- FM MONO
This receiver will decode the signal as mono signal regardless of the broadcast signal.

■ NAME IN (Naming preset stations)

Lets you set the name of preset stations. For details, see “Naming preset stations” (page 68).

Settings for the audio

(AUDIO menu)

You can use the AUDIO menu to make settings for the audio to suit your preference. Select “5-AUDIO” in the amplifier menus. For details on adjusting the parameters, see “Navigating through menus” (page 44) and “Overview of the menus” (page 45).

AUDIO menu parameters

■ DEC. PRI. (Digital audio input decoding priority)

Lets you specify the input mode for the digital signal input to the DIGITAL IN and HDMI IN jacks.

- DEC. AUTO
Automatically switches the input mode between DTS, Dolby Digital, or PCM.
- DEC. PCM
PCM signals are given priority (to prevent interruption when playback starts).
However, when other signals are input, there may be no sound depending on the format. In this case, set to “DEC. AUTO”.
When signals from the HDMI IN jack are selected, only PCM signals are output from the connected component. When signals other than PCM signals are received, set this item to “DEC. AUTO”.

Note

When set to “DEC. AUTO” and the sound from the digital audio jacks (for a CD, etc.) is interrupted when playback starts, set to “DEC. PCM”.

■ DUAL (Digital broadcast language selection)

Lets you select the language you want to listen to during digital broadcast. This feature only functions for Dolby Digital sources.

- DUAL M/S (Main/Sub)
Sound of the main language will be output through the front left speaker and sound of the sub language will be output through the front right speaker simultaneously.
- DUAL M (Main)
Sound of the main language will be output.
- DUAL S (Sub)
Sound of the sub language will be output.
- DUAL M+S (Main + Sub)
Mixed sound of both the main and sub languages will be output.

■ A.V. SYNC. (Synchronizes audio with video output)

Lets you delay the output of audio to minimize the time gap between audio output and visual display. You can adjust from 0 (0 ms) to 20 (200 ms) in 1 (10 ms) steps.

Notes

- This parameter is useful when you use a large LCD or plasma monitor or a projector.
- This parameter is not valid when
 - the multi channel PCM signals are received via a HDMI IN jack.
 - ANALOG DIRECT is selected.

■ D. ASSIGN (Digital audio input assignment)

Lets you assign the digital audio input to other input source. For details, see “Listening to digital sound from other inputs (DIGITAL ASSIGN)” (page 72).

■ NAME IN (Naming inputs)

Lets you set the name of inputs. For details, see “Naming inputs” (page 76).

Settings for the video

(VIDEO menu)

You can use the VIDEO menu to make various adjustments for HDMI settings, assign the composite video input to DMPORT input, etc. Select “6-VIDEO” in the amplifier menus. For details on adjusting the parameters, see “Navigating through menus” (page 44) and “Overview of the menus” (page 45).

VIDEO menu parameters

■ OSD (On-Screen Display on/off)

Lets you view the amplifier menus on the TV screen and you can adjust the settings easily.

- OSD ON

The on-screen display is turned on so that the amplifier menus are displayed on the TV screen.

- OSD OFF

The on-screen display is turned off.

Note

The on-screen display is not output from the COMPONENT VIDEO MONITOR OUT jack of the receiver. Be sure to connect the HDMI OUT or MONITOR VIDEO OUT jack to your TV.

■ DMPORT V. (DIGITAL MEDIA PORT video assign)

Lets you assign the composite video input to DMPORT input so that you can view the images on the TV screen. For details, see “Watching a connected component through DMPORT connection” (page 75).

■ AUDIO (HDMI AUDIO)^{a)}

Lets you set the HDMI audio output from the playback component connected to the receiver via a HDMI connection.

- AMP

The HDMI audio signals from the playback component is only output to the speakers connected to the receiver. Multi channel sound can be played back as it is.

Note

Sound is not output from the TV’s speakers.

- TV+AMP

The sound is output from TV’s speaker and the speakers connected to the receiver.

Notes

- The sound quality of the playback component depends on the TV’s sound quality, such as the number of channels, and the sampling frequency, etc. When the TV has stereo speakers, the sound output from the receiver is also stereo as that of the TV, even if you play back multi channel software.
- When you connect the receiver to an image display component (projector, etc.), sound may not be output from the receiver. In this case, select “AMP”.

■ CONTROL (HDMI CONTROL)^{a)}

Lets you turn the HDMI CONTROL function on or off. For details, refer to the “HDMI CONTROL Guide” supplied with the receiver.

■ COL SYS (Color TV type selection)^{b)}

- COL NTSC
- COL PAL

■ NAME IN (Naming inputs)

Lets you set the name of inputs. For details, see “Naming inputs” (page 76).

^{a)}When you select this parameter, the “HDMI” flashes on the display.

^{b)}Models of area code CEL, CEK, E2 only.

Settings for the system (SYSTEM menu)

You can use the SYSTEM menu to set the size and distance of the speakers connected to this receiver.

Select “7-SYSTEM” in the amplifier menus. For details on adjusting the parameters, see “Navigating through menus” (page 44) and “Overview of the menus” (page 45).

SYSTEM menu parameters

■ SW SPK (Sub woofer)

- YES
If you have connected a sub woofer, select “YES”.
- NO
If you have not connected a sub woofer, select “NO”. This activates the bass redirection circuitry and outputs the LFE signals from other speakers.

Tip

In order to take full advantage of the Dolby Digital bass redirection circuitry, we recommend setting the sub woofer’s cut off frequency as high as possible.

■ FRT SPK (Front speakers)

- LARGE
If you connect large speakers that will effectively reproduce bass frequencies, select “LARGE”. Normally, select “LARGE”. When the sub woofer is set to “NO”, the front speakers are automatically set to “LARGE”.
- SMALL
If the sound is distorted, or you feel a lack of surround effects when using multi channel surround sound, select “SMALL” to activate the bass redirection circuitry and output the front channel bass frequencies from the sub woofer. When the front speakers are set to “SMALL”, the center and surround speakers are also automatically set to “SMALL” (unless previously set to “NO”).

■ CNT SPK (Center speaker)

- LARGE
If you connect a large speaker that will effectively reproduce bass frequencies, select “LARGE”. Normally, select “LARGE”. However, if the front speakers are set to “SMALL”, you cannot set the center speaker to “LARGE”.
- SMALL
If the sound is distorted, or you feel a lack of surround effects when using multi channel surround sound, select “SMALL” to activate the bass redirection circuitry and output the center channel bass frequencies from the front speakers (if set to “LARGE”) or sub woofer.
- NO
If you have not connected a center speaker, select “NO”. The sound of the center channel will be output from the front speakers.

■ SUR SPK (Surround speakers)

The surround back speakers will be set to the same setting.

- LARGE
If you connect large speakers that will effectively reproduce bass frequencies, select “LARGE”. Normally, select “LARGE”. However, if the front speakers are set to “SMALL”, you cannot set the surround speakers to “LARGE”.
- SMALL
If the sound is distorted, or you feel a lack of surround effects when using multi channel surround sound, select “SMALL” to activate the bass redirection circuitry and output the surround channel bass frequencies from the sub woofer or other speaker that is set to “LARGE”.
- NO
If you have not connected surround speakers, select “NO”.

continued

55^{GB}

■ SB SPK (Surround back speakers)

When the surround speakers are set to “NO”, the surround back speakers are also automatically set to “NO” and the setting cannot be changed.

- DUAL

If you connect two surround back speakers, select “DUAL”. The sound will be output to a maximum of 7.1 channel.

- SINGLE

If you connect only one surround back speaker, select “SINGLE”. The sound will be output to a maximum of 6.1 channel.

- NO

If you have not connected a surround back speaker, select “NO”.

Tip

The “LARGE” and “SMALL” settings for each speaker determine whether the internal sound processor will cut the bass signal from that channel. When the bass is cut from a channel, the bass redirection circuitry sends the corresponding bass frequencies to the sub woofer or other “LARGE” speakers.

However, since bass sounds have a certain amount of directionality, it is best not to cut them, if possible. Therefore, even when using small speakers, you can set them to “LARGE” if you want to output the bass frequencies from that speaker. On the other hand, if you are using a large speaker, but prefer not to have bass frequencies output from that speaker, set it to “SMALL”.

If the overall sound level is lower than you prefer, set all speakers to “LARGE”. If there is not enough bass, you can use the equalizer to boost the bass levels. For details, see page 45.

■ FL DIST. (Front left speaker distance)

■ FR DIST. (Front right speaker distance)

Lets you set the distance from your listening position to the front speakers (A).

If both front speakers are not placed an equal distance from your listening position, set the distance to the closest speaker.

With only one surround back speaker

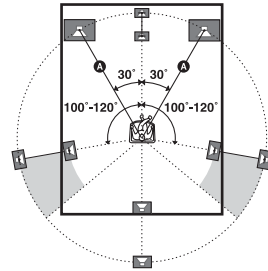

With two surround back speakers (The angle B should be the same)

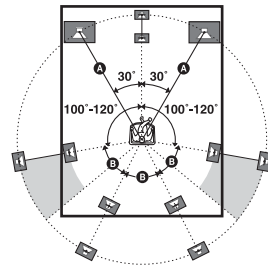

■ CNT DIST. (Center speaker distance)

Lets you set the distance from your listening position to the center speaker.

■ SL DIST. (Surround left speaker distance)

■ SR DIST. (Surround right speaker distance)

Lets you set the distance from your listening position to the surround speakers.

If both surround speakers are not placed an equal distance from your listening position, set to the distance to the closest speaker.

■ SB DIST. (Surround back speaker distance)^{a)}

■ SBL DIST. (Surround back left speaker distance)^{b)}

■ SBR DIST. (Surround back right speaker distance)^{b)}

Lets you set the distance from your listening position to the surround back speakers.

If you connect two surround back speakers and both surround back speakers are not placed an equal distance from your listening position, set the distance to the closest speaker.

^{a)}You can only select this parameter when the surround back speakers are set to “SINGLE” in SYSTEM menu.

^{b)}You can only select this parameter when the surround back speakers are set to “DUAL” in SYSTEM menu.

■ SW DIST. (Sub woofer distance)

Lets you set the distance from your listening position to the sub woofer.

Tips

- If you set “CAL LOAD” in A. CAL menu to “LOAD YES”, you can adjust the speakers distance in 0.01 meter increment.
- The distance between the center speaker and the listening position [B] cannot be more than 1.5 meters closer than the one between the listening position and the front speaker [A]. Place the speakers so that the difference in the length of [B] in the following diagram is no more than 1.5 meters closer than the length of [A].

Example: Adjust the distance [B] to 4.5 meters or more when the distance [A] is 6 meters.

Also, the distance between the surround speakers/ surround back speakers and the listening position [C] cannot be more than 4.5 meters closer than the distance between the listening position and the front speakers [A]. Place the speakers so that the difference in the length of [C] in the following diagram is no more than 4.5 meters closer than the length of [A].

Example: Adjust the distance [C] to 1.5 meters or more when the distance [A] is 6 meters.

This is important because incorrect speaker placement is not conducive to the enjoyment of surround sound. Please note that placing the speakers closer than the required will cause a delay in the output of the sound from that speaker. In other words, the speaker will sound like it is farther away.

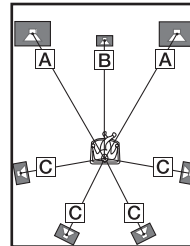

■ SUR POS. (Surround speaker position)

Lets you specify the location of your surround speakers for proper implementation of the surround effects in the CINEMA STUDIO EX modes (page 62). This parameter is not available when the surround speakers are set to “NO” (page 47).

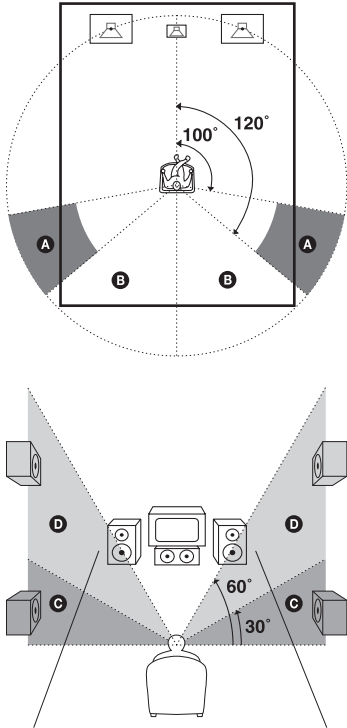

- **SIDE/LO**
Select if the location of your surround speakers corresponds to sections **A** and **C**.
- **SIDE/HI**
Select if the location of your surround speakers corresponds to sections **A** and **D**.
- **BEHD/LO**
Select if the location of your surround speakers corresponds to sections **B** and **C**.
- **BEHD/HI**
Select if the location of your surround speakers corresponds to sections **B** and **D**.

Tip

Surround speaker position is designed specifically for implementation of the CINEMA STUDIO EX modes. For other sound fields, speaker position is not so critical.

Those sound fields were designed under the premise that the surround speakers would be located behind the listening position, but presentation remains fairly consistent even with the surround speakers positioned at a rather wide angle. However, if the speakers are pointing toward the listener from the immediate left and right of the listening position, the surround effects become unclear unless set to “SIDE/LO” or “SIDE/HI”.

Nevertheless, each listening environment has many variables, such as wall reflections, and you may obtain better results using “BEHD/HI” if your speakers are located high above the listening position, even if they are located to the immediate left and right.

Therefore, although it may result in a setting contrary to the above explanation, we recommend that you play back multi channel surround encoded software and select the setting that provides a good sense of spaciousness and that best succeeds in forming a cohesive space between the surround sound from the surround speakers and the sound of the front speakers. If you are not sure which sounds best, select “BEHD/LO” or “BEHD/HI” and then use the speaker distance parameter and speaker level adjustments to obtain proper balance.

■ CRS. FREQ (Speaker crossover frequency)

Lets you set the bass crossover frequency of the speakers that have been set to “SMALL” in the SYSTEM menu. This parameter is only available when at least one speaker is set to “SMALL”.

Note

This parameter is not available when “CAL LOAD” is set to “LOAD YES” in A. CAL menu. In this case, set to “LOAD NO”.

■ DIMMER (Brightness of the display)

Lets you adjust the brightness in 3 steps. You can also use DIMMER on the receiver.

Enjoying Dolby Digital and DTS surround sound (AUTO FORMAT DIRECT)

The Auto Format Direct (A.F.D.) mode allows you to listen to higher fidelity sound and select the decoding mode for listening to a 2 channel stereo sound as multi channel sound.

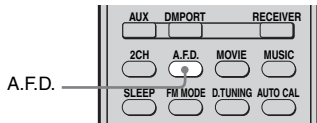

Press A.F.D. repeatedly to select the sound field you want.

For details, see “Types of A.F.D. mode” (page 60).

Types of A.F.D. mode

Decoding mode	A.F.D. mode [Display]	Multi channel audio after decoding	Effect
(Detecting automatically)	A.F.D. AUTO [A.F.D. AUTO]	(Detecting automatically)	Presents the sound as it was recorded/ encoded without adding any surround effects. However, this receiver will generate a low frequency signal for output to the sub woofer when there is no LFE signals.
Dolby Pro Logic	PRO LOGIC [DOLBY PL]	4 channel	Performs Dolby Pro Logic decoding. The source recorded in 2 channel format is decoded into 4.1 channel.
Dolby Pro Logic II	PRO LOGIC II MOVIE [PLII MV]	5 channel	Performs Dolby Pro Logic II Movie mode decoding. This setting is ideal for movies encoded in Dolby Surround. In addition, this mode can reproduce sound in 5.1 channel for watching videos of overdubbed or old movies.
	PRO LOGIC II MUSIC [PLII MS]	5 channel	Performs Dolby Pro Logic II Music mode decoding. This setting is ideal for normal stereo sources such as CDs.
	PRO LOGIC II GAME [PLII GM]	5 channel	Performs Dolby Pro Logic II Game mode decoding. This setting is ideal for game softwares.
Dolby Pro Logic IIx	PRO LOGIC IIx MOVIE [PLIIX MV]	7 channel	Performs Dolby Pro Logic IIx Movie mode decoding. This setting expands Dolby Pro Logic II Movie or Dolby Digital 5.1 to discrete 7.1 movie channels.
	PRO LOGIC IIx MUSIC [PLIIX MS]	7 channel	Performs Dolby Pro Logic IIx Music mode decoding. This setting is ideal for normal stereo sources such as CDs.
	PRO LOGIC IIx GAME [PLIIX GM]	7 channel	Performs Dolby Pro Logic IIx Game mode decoding.
Neo:6	Neo:6 Cinema [NEO6 CIN]	6 channel	Performs DTS Neo:6 Cinema mode decoding.
	Neo:6 Music [NEO6 MUS]	6 channel	Performs DTS Neo:6 Music mode decoding. This setting is ideal for normal stereo sources such as CDs.
(Multi Stereo)	MULTI STEREO [MULTI ST.]	(Multi Stereo)	Outputs 2 channel left/right signals from all speakers. However, sound may not be output from certain speakers depending on the speaker settings.

If you connect a sub woofer

This receiver will generate a low frequency signal for output to the sub woofer when there is no LFE signal, which is a low-pass sound effect output from a sub woofer to a 2 channel signal. However, the low frequency signal is not generated for “NEO6 CIN” or “NEO6 MUS” when all speakers are set to “LARGE”.

Notes

- This function does not work when ANALOG DIRECT is selected.
- DTS Neo:6 does not work for DTS 2CH audio, the sound is played as 2 channel.
- Dolby Pro Logic IIx decoding does not function for signals with a sampling frequency of more than 48 kHz.

Tip

When a multi channel signal is input, only Dolby Pro Logic IIx decoding is effective. When you select decoding modes other than Dolby Pro Logic IIx, multi channel sound (being encoded) is output.

Selecting a pre-programmed sound field

You can take advantage of surround sound simply by selecting one of the receiver’s pre-programmed sound fields. They bring the exciting and powerful sound of movie theaters and concert halls into your home.

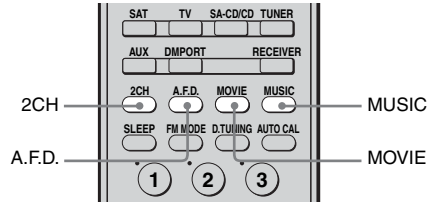

Press MOVIE repeatedly to select a sound field for movies or press MUSIC repeatedly to select a sound field for music.

For details, see “Types of sound field available” (page 62).

Types of sound field available

Sound field for	Sound field [Display]	Effect
Movie	CINEMA STUDIO EX A DCS [C.ST.EX A]	Reproduces the sound characteristics of the Sony Pictures Entertainment "Cary Grant Theater" cinema production studio. This is a standard mode, great for watching almost any type of movie.
	CINEMA STUDIO EX B DCS [C.ST.EX B]	Reproduces the sound characteristics of the Sony Pictures Entertainment "Kim Novak Theater" cinema production studio. This mode is ideal for watching science-fiction or action movies with lots of sound effects.
	CINEMA STUDIO EX C DCS [C.ST.EX C]	Reproduces the sound characteristics of the Sony Pictures Entertainment scoring stage. This mode is ideal for watching musicals or films where orchestra music is featured in the soundtrack.
Music	PORTABLE AUDIO [PORTABLE]	Reproduces a clear enhanced sound image from your portable audio device. This mode is ideal for MP3 and other compressed music.
	HALL [HALL]	Reproduces the acoustics of a classical concert hall.
	JAZZ CLUB [JAZZ]	Reproduces the acoustics of a jazz club.
	LIVE CONCERT [CONCERT]	Reproduces the acoustics of a 300-seat live house.
Headphone*	HEADPHONE 2CH [HP 2CH]	This mode is selected automatically if you use headphones when 2CH STEREO mode (page 64)/A.F.D. mode (page 60) is selected. Standard 2 channel stereo sources completely bypass the sound field processing and multi channel surround formats are downmixed to 2 channels.
	HEADPHONE THEATER DCS [HP THEA]	This mode is selected automatically if you use headphones when sound field for movie/music is selected. It allows you to experience a theater-like environment while listening through a pair of headphones.
	HEADPHONE DIRECT [HP DIR]	Outputs the analog signals without processing by the equalizer, sound field, etc.

* You can only select this sound field if the headphones are connected to the receiver.

About DCS (Digital Cinema Sound)

Sound fields with **DCS** mark use DCS technology.

DCS is a unique sound reproduction technology for home theater developed by Sony, in cooperation with Sony Pictures Entertainment, for enjoying the exciting and powerful sound of movie theaters at home. With this “Digital Cinema Sound” developed by integrating a DSP (Digital signal processor) and measured data, the ideal sound field intended by film makers can be experienced at home.

About CINEMA STUDIO EX modes

CINEMA STUDIO EX modes are suitable for watching motion picture DVDs (etc.), with multi channel surround effects. You can reproduce the sound characteristics of Sony Pictures Entertainment’s dubbing studio in your home.

The CINEMA STUDIO EX modes consist of the following three elements.

- **Virtual Multi Dimension**
Creates 5 sets of virtual speakers from a single pair of actual surround speakers.
- **Screen Depth Matching**
Creates the sensation that the sound is coming from inside the screen like in theaters.
- **Cinema Studio Reverberation**
Reproduces the type of reverberation found in theaters.



The CINEMA STUDIO EX modes integrate these three elements simultaneously.

Notes

- The effects provided by the virtual speakers may cause increased noise in the playback signal.
- When listening with sound fields that employ the virtual speakers, you will not be able to hear any sound coming directly from the surround speakers.
- This function does not work in the following cases:
 - ANALOG DIRECT is selected.
 - For signals with a sampling frequency of more than 48 kHz.
 - The multi channel PCM signals are received via a HDMI IN jack.
- The surround back decoding mode does not function when a sound field for movie or music is selected (page 51).
- When one of the following sound fields is selected, no sound is output from the sub woofer if all the speakers are set to “LARGE” in the SYSTEM menu. However, the sound will be output from the sub woofer if the digital input signal contains LFE signals, or if the front or surround speakers are set to “SMALL”.
 - HALL
 - JAZZ CLUB
 - LIVE CONCERT

Tip

You can identify the encoding format of DVD software, etc., by looking at the logo on the package.

-  : Dolby Digital discs
-  : Dolby Surround encoded programs
-  : DTS Digital Surround encoded programs

To turn off the surround effect for movie/music

Press 2CH to select “2CH ST.” or press A.F.D. repeatedly to select “A.F.D. AUTO”.

Using only the front speakers (2CH STEREO)

In this mode, the receiver outputs the sound from the front left/right speakers only. There is no sound from the sub woofer. Standard 2 channel stereo sources completely bypass the sound field processing and multi channel surround formats are downmixed to 2 channel.

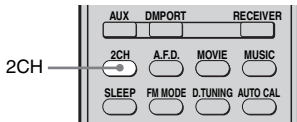

Press 2CH.

Note

No sound is output from the sub woofer in the 2CH STEREO mode. To listen to 2 channel stereo sources using the front left/right speakers and a sub woofer, select "A.F.D. AUTO" (page 60).

Listening to the sound without any adjustment (ANALOG DIRECT)

You can switch the audio of the selected input to 2 channel analog input. This function enables you to enjoy high quality analog sources.

When using this function, only the volume and front speaker balance can be adjusted.

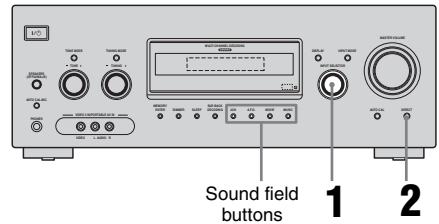

1 Turn INPUT SELECTOR on the receiver to select the input you want to listen to in analog audio.

You can also use the input buttons on the remote.

2 Press DIRECT on the receiver.

"A. DIRECT" appears on the display. The analog audio is output.

To cancel ANALOG DIRECT

Press DIRECT on the receiver again. You can also press any sound field buttons.

Notes

- When headphones are connected, "HP DIR" appears on the display.
- This function is not available when DMPORT input is selected.

Resetting sound fields to the initial settings

Be sure to use the buttons on the receiver for this operation.

1,2

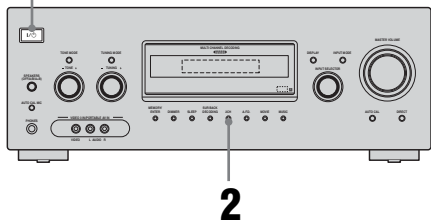

- 1** Press I/O to turn off the receiver.
- 2** While holding down 2CH, press I/O.
“S.F. CLR.” appears on the display and all sound fields are reset to their initial setting.

Tuner Operations

Listening to FM/AM radio

You can listen to FM and AM broadcasts through the built-in tuner. Before operation, make sure you have connected the FM and AM antennas to the receiver (page 30).

Tip

The tuning scale for direct tuning differs depending on the area code as shown in the following table. For details on area codes, see page 2.

Area	FM	AM
CEL, CEK, TW, KR	50 kHz	9 kHz
E2	50 kHz	9 kHz*

* The AM tuning scale can be changed (page 91).

Automatic tuning

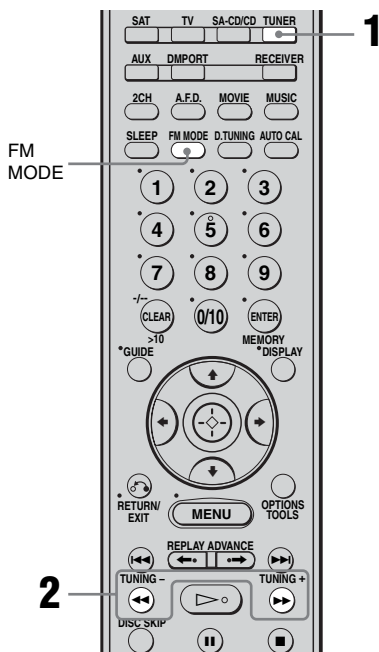

1 Press TUNER repeatedly to select the FM or AM band.

2 Press TUNING + or TUNING –.

Press TUNING + to scan from low to high; press TUNING – to scan from high to low.

The receiver stops scanning whenever a station is received.

Using the controls on the receiver

1 Turn INPUT SELECTOR to select the FM or AM band.

2 Press TUNING MODE repeatedly to select “AUTO T.”.

3 Turn TUNING +/-.

In case of poor FM stereo reception

If the FM stereo reception is poor and “ST” flashes on the display, select monaural audio so that the sound will be less distorted.

- To select monaural audio, you can
 - press FM MODE repeatedly until the “MONO” indicator lights up on the display.
 - set “FM MODE” in TUNER menu to “FM MONO” (page 52).
- To return to stereo mode, you can
 - press FM MODE repeatedly until the “MONO” indicator on the display do not light up.
 - set “FM MODE” in TUNER menu to “FM AUTO” (page 52).

Direct tuning

You can enter the frequency of a station directly by using the numeric buttons.

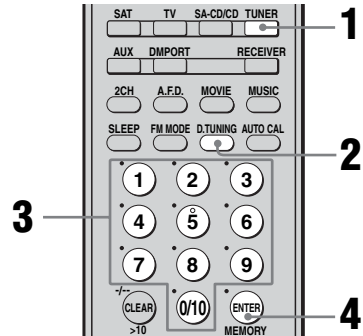

1 Press TUNER repeatedly to select the FM or AM band.

You can also use INPUT SELECTOR on the receiver.

2 Press D.TUNING.

3 Press the numeric buttons to enter the frequency.

Example 1: FM 102.50 MHz

Select 1 → 0 → 2 → 5 → 0

Example 2: AM 1,350 kHz

Select 1 → 3 → 5 → 0

4 Press ENTER.

You can also use MEMORY/ENTER on the receiver.

Tip

If you have tuned in an AM station, adjust the direction of the AM loop antenna for optimum reception.

If you cannot tune in a station

Make sure you have entered the right frequency. If not, repeat steps 2 to 4. If you still cannot tune in a station, the frequency is not used in your area.

Presetting radio stations

You can preset up to 30 FM stations and 30 AM stations. Then you can easily tune in the stations you often listen to.

Presetting radio stations

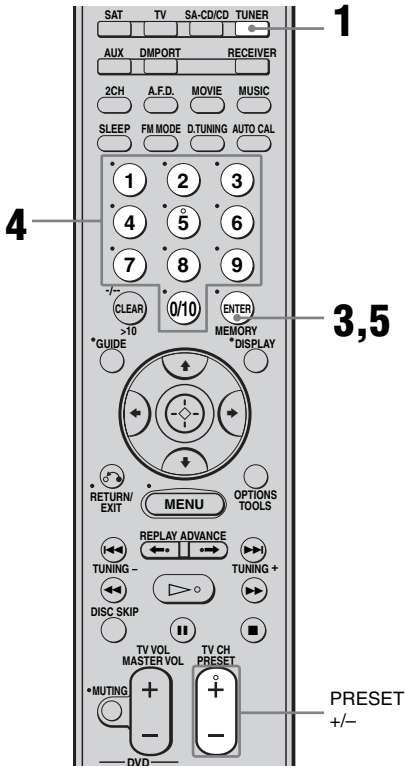

3 Press MEMORY.

You can also use MEMORY/ENTER on the receiver.

“MEMORY” lights up for a few seconds. Perform steps 4 and 5 before “MEMORY” goes out.

4 Press the numeric buttons to select a preset number.

You can also press PRESET + or PRESET – to select a preset number. If “MEMORY” goes out before you select the preset number, start again from step 3.

5 Press ENTER.

You can also use MEMORY/ENTER on the receiver. The station is stored as the selected preset number. If “MEMORY” goes out before you press ENTER, start again from step 3.

6 Repeat steps 1 to 5 to preset another station.

1 Press TUNER repeatedly to select the FM or AM band.

You can also use INPUT SELECTOR on the receiver.

2 Tune in the station that you want to preset using Automatic Tuning (page 65) or Direct Tuning (page 66).

Switch the FM reception mode, if necessary (page 66).

Tuning to preset stations

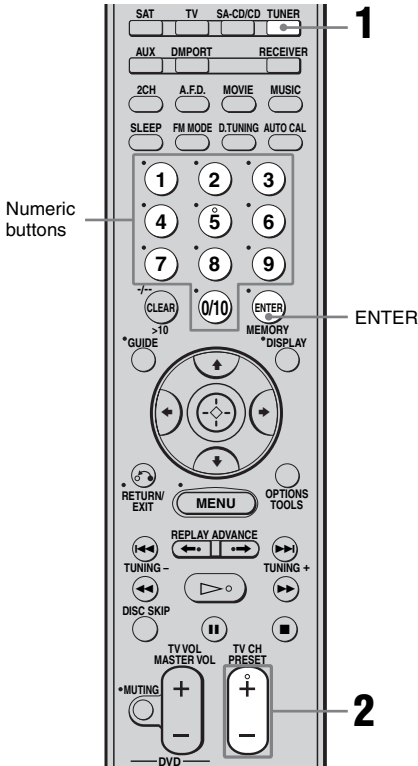

- 1 Press **TUNER** repeatedly to select the FM or AM band.
- 2 Press **PRESET +** or **PRESET -** repeatedly to select the preset station you want.

Each time you press the button, you can select a preset station as follows:

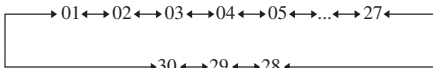

You can also press the numeric buttons to select the preset station you want. Then, press **ENTER** to enter the selection.

Using the controls on the receiver

- 1 Turn **INPUT SELECTOR** to select the FM or AM band.
- 2 Press **TUNING MODE** repeatedly to select “PRESET T.”.
- 3 Turn **TUNING +/-** to select the preset station you want.

Naming preset stations

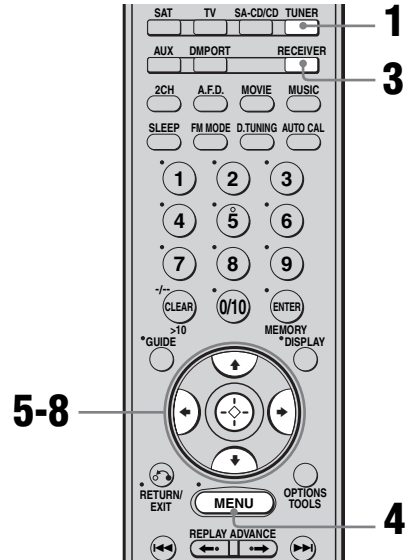

- 1 Press **TUNER** repeatedly to select the FM or AM band.
You can also use **INPUT SELECTOR** on the receiver.
- 2 Tune in the preset station you want to create an index name for (page 68).
- 3 Press **RECEIVER**.
The **RECEIVER** indicator lights up and receiver operation is activated.
- 4 Press **MENU**.
“1-LEVEL” appears on the display.

5 Press **▲/▼** repeatedly to select “4-TUNER”.

6 Press **⊕** or **▶** to enter the menu.

7 Press **▲/▼** repeatedly to select “NAME IN”.

8 Press **⊕** or **▶** to enter the parameter.

The cursor flashes and you can select a character. Follow the procedure given in “To create an index name” below.

To create an index name

1 Use **▲/▼/◀/▶** to create an index name. Press **▲/▼** to select a character, then press **◀/▶** to move the cursor to the next position.

If you made a mistake

Press **◀/▶** until the character you want to change flashes, then press **▲/▼** to select the correct character.

Tips

- You can select the character type as follows by pressing **▲/▼**.
Alphabet (upper case) → Numbers → Symbols
- To enter a blank space, you can
 - press **▲/▼** repeatedly until a blank space appears in the display.
 - press **▶** without input a character.

2 Press **⊕** to enter the name.
The entered name is registered.

Note (Models of area code CEL, CEK only)

When you name an RDS station and tune in that station, the Program Service name appears instead of the name you entered. (You cannot change the Program Service name. The name you entered will be overwritten by the Program Service name.)

Using the Radio Data System (RDS)

(Models of area code CEL, CEK only)

This receiver also allows you to use RDS (Radio Data System), which enables radio stations to send additional information along with the regular program signal. You can display RDS information.

Notes

- RDS is operable only for FM stations.
- Not all FM stations provide RDS service, nor do they provide the same type of services. If you are not familiar with the RDS services in your area, check with your local radio stations for details.

Receiving RDS broadcasts

Simply select a station on the FM band using Direct Tuning (page 66), Automatic Tuning (page 65), or Preset Tuning (page 67).

When you tune in a station that provides RDS services, “RDS” lights up and the program service name appears on the display.

Note

RDS may not work properly if the station you tuned to is not transmitting the RDS signal properly or if the signal strength is weak.

Displaying RDS information

While receiving an RDS station, press DISPLAY repeatedly on the receiver.

Each time you press the button, RDS information on the display changes cyclically as follows:

Program Service name → Frequency → Program Type indication^{a)} → Radio Text indication^{b)} → Current Time indication (in 24-hour system mode) → Sound field currently applied

^{a)}Type of program being broadcast.

^{b)}Text messages sent by the RDS station.

Notes

- If there is an emergency announcement by government authorities, "ALARM" flashes in the display.
- When the message consists of 9 characters or more, the message scrolls across the display.
- If a station does not provide a particular RDS service, "NO XXXX" (such as "NO TEXT") appears on the display.

Description of program types

Program type indication	Description
NEWS	News programs
AFFAIRS	Topical programs that expand on current news
INFO	Programs offering information on a wide spectrum of subjects, including consumer affairs and medical advice
SPORT	Sports programs
EDUCATE	Educational programs, such as "how-to" and advice programs
DRAMA	Radio plays and serials
CULTURE	Programs about national or regional culture, such as language and social concerns
SCIENCE	Programs about the natural sciences and technology

Program type indication	Description
VARIED	Other types of programs such as celebrity interviews, panel games, and comedy
POP M	Popular music programs
ROCK M	Rock music programs
EASY M	Easy Listening
LIGHT M	Instrumental, vocal, and choral music
CLASSICS	Performances of major orchestras, chamber music, opera, etc.
OTHER M	Music that does not fit into any categories above, such as Rhythm & Blues and Reggae
WEATHER	Weather information
FINANCE	Stock market reports and trading, etc.
CHILDREN	Programs for children
SOCIAL	Programs about people and the things that affect them
RELIGION	Programs of religious content
PHONE IN	Programs where members of the public express their views by phone or in a public forum
TRAVEL	Programs about travel. Not for announcements that are located by TP/TA.
LEISURE	Programs on recreational activities such as gardening, fishing, cooking, etc.
JAZZ	Jazz programs
COUNTRY	Country music programs
NATION M	Programs featuring the popular music of the country or region
OLDIES	Programs featuring oldies music
FOLK M	Folk music programs
DOCUMENT	Investigative features
NONE	Any programs not defined above

Switching between digital and analog audio (INPUT MODE)

You can select the audio input mode setting when you connect components to both digital and analog audio input jacks on the receiver.

1 Turn INPUT SELECTOR on the receiver to select the input.

You can also use the input buttons on the remote.

2 Press INPUT MODE repeatedly on the receiver to select the audio input mode.

The selected audio input mode appears on the display.

Audio input modes

■ AUTO IN

Gives priority to digital audio signals when there are both digital and analog connections. If there are no digital audio signals, analog audio signals are selected.

■ HDMI IN

Specifies the audio signals input to the HDMI jack.

■ COAX IN

Specifies the digital audio signals input to the DIGITAL COAXIAL jack.

■ OPT IN

Specifies the digital audio signals input to the DIGITAL OPTICAL jack.

■ ANALOG

Specifies the analog audio signals input to the AUDIO IN (L/R) jacks.

Notes

- Some audio input modes may not be set up depending on the input.
- When the ANALOG DIRECT function is selected, audio input is set to “ANALOG” automatically and you cannot select other modes.

Listening to digital sound from other inputs

(DIGITAL ASSIGN)

You can reassign digital audio input that has OPTICAL or COAXIAL (VIDEO 1 IN, VIDEO 2/BD IN, DVD IN, SAT IN, SA-CD/CD/CD-R IN) signals to another input when they are not currently being used.

For example, to output the sound source for DVD player using the OPTICAL IN jack on the receiver, then:

- Connect the optical output jack of the DVD player to the OPTICAL VIDEO 2/BD IN jack of the receiver.
- Assign “VD2 OPT” to “DVD” in the DIGITAL ASSIGN setting.

1 Press RECEIVER.

The RECEIVER indicator lights up and receiver operation is activated.

2 Press MENU.

“1-LEVEL” appears on the display.

3 Press \uparrow/\downarrow repeatedly to select “5-AUDIO”.

4 Press \odot or \rightarrow to enter the menu.

5 Press \uparrow/\downarrow repeatedly to select “D. ASSIGN”.

6 Press \odot or \rightarrow to enter the parameter.

7 Press \uparrow/\downarrow repeatedly to select the digital audio input you want to reassign (for example, “VD2 OPT”).

8 Press \odot or \rightarrow to enter your selection.

9 Press \uparrow/\downarrow repeatedly to select the input you want the digital audio input selected in step 7 to be reassigned to (for example, “VD2-DVD”).

If an input is switched to “DVD”, the sound of the DVD player will also become a digital sound through the OPTICAL VIDEO 2/BD IN jack.

The input you can reassign to varies for each digital audio input. For details, see “Assignable inputs for digital audio input” (page 73).

To return to the previous display

Press \leftarrow .

Assignable inputs for digital audio input

The initial setting is marked with an underscore.

Digital audio input [Display]	Assignable inputs	Display
VIDEO 1 OPTICAL [VD1 OPT]	VIDEO 1	<u>VD1-VD1</u>
	VIDEO 3	VD1-VD3
	DVD	VD1-DVD
	TV	VD1-TV
	SA-CD/CD	VD1-CD
VIDEO2/BD OPTICAL [VD2 OPT]	VIDEO 2	<u>VD2-VD2</u>
	VIDEO 3	VD2-VD3
	DVD	VD2-DVD
	TV	VD2-TV
	SA-CD/CD	VD2-CD
DVD COAXIAL [DVD COAX]	VIDEO 1	DVD-VD1
	VIDEO 2	DVD-VD2
	VIDEO 3	DVD-VD3
	DVD	<u>DVD-DVD</u>
	SAT	DVD-SAT
	TV	DVD-TV
SAT OPTICAL [SAT OPT]	VIDEO 3	SAT-VD3
	DVD	SAT-DVD
	SAT	<u>SAT-SAT</u>
	TV	SAT-TV
	SA-CD/CD	SAT-CD
SA-CD/CD/ CD-R COAXIAL [CD COAX]	VIDEO 1	CD-VD1
	VIDEO 2	CD-VD2
	VIDEO 3	CD-VD3
	SAT	CD-SAT
	TV	CD-TV
	SA-CD/CD	<u>CD-CD</u>

Notes

- You cannot reassign more than one digital audio input to the same input.
- You cannot use the digital audio input for the original input when it is reassigned to another input.
- When you reassign the digital audio input, the INPUT MODE setting may change automatically (page 71).
- You cannot reassign the digital audio input to TUNER, AUX and DMPORT input.

Enjoying the DIGITAL MEDIA PORT (DMPORT)

The DIGITAL MEDIA PORT (DMPORT) allows you to enjoy sound from a network system such as a portable audio source or computer.

By connecting a DIGITAL MEDIA PORT adapter (not supplied), you can enjoy sound from the connected component on the receiver.

For details, see the operating instructions supplied with the DIGITAL MEDIA PORT adapter.

Notes

- Do not connect an adapter other than the DIGITAL MEDIA PORT adapter.
- Do not connect or disconnect the DIGITAL MEDIA PORT adapter while the receiver is turned on.
- Depending on the DIGITAL MEDIA PORT adapter, video output may not be possible.
- The DIGITAL MEDIA PORT adapters are available for purchase depending on the area.

Connecting the DIGITAL MEDIA PORT adapter

You can listen to the sound from the component connected through the DIGITAL MEDIA PORT adapter to the DMPORT jack on the receiver.

You can also view the images on the TV screen by connecting the video output of the DIGITAL MEDIA PORT adapter to the receiver.

To view the images, proceed to “Watching a connected component through DMPORT connection” on page 75.

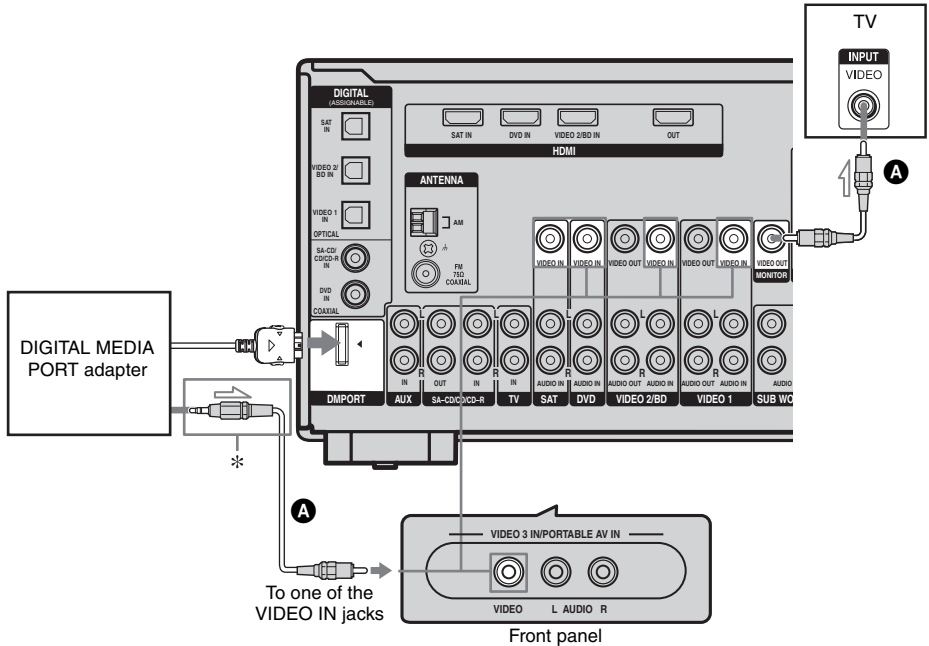

* The type of connector varies depending on the DIGITAL MEDIA PORT adapter. For details, see the operating instructions supplied with the DIGITAL MEDIA PORT adapter.

A Video cord (not supplied)

To detach the DIGITAL MEDIA PORT adapter from DMPORT jack

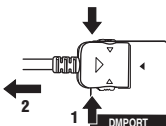

Press and hold both sides of the connector and then pull out the connector.

Notes

- When connecting the DIGITAL MEDIA PORT adapter, be sure the connector is inserted with the arrow mark facing towards the arrow mark on the DMPORT jack.
- Be sure to make DMPORT connections firmly, insert the connector straight in.
- As the connector of the DIGITAL MEDIA PORT adapter is fragile, be sure to handle with care when placing or moving the receiver.

Listening to a connected component through DMPORT connection

1 Press DMPORT.

You can also use the INPUT SELECTOR on the receiver to select “DMPORT”.

2 Start playback of the connected component.

The sound is played back on the receiver. For details, see the operating instructions supplied with the DIGITAL MEDIA PORT adapter.

Watching a connected component through DMPORT connection

You need to assign composite video input to DMPORT input so that you can view the images on the TV screen.

1 Press RECEIVER.

The RECEIVER indicator lights up and receiver operation is activated.

2 Press MENU.

“1-LEVEL” appears on the display.

3 Press \uparrow/\downarrow repeatedly to select “6-VIDEO”.

4 Press $\left(\begin{smallmatrix} \circ \\ \circ \end{smallmatrix}\right)$ or \rightarrow to enter the menu.

5 Press \uparrow/\downarrow repeatedly to select “DMPORT V.”.

6 Press $\left(\begin{smallmatrix} \circ \\ \circ \end{smallmatrix}\right)$ or \rightarrow to enter the parameter.

7 Press \uparrow/\downarrow repeatedly to select the composite video input you want to assign to DMPORT input.

Initial setting: –NONE

The assignable composite video input are VIDEO 1, VIDEO 2, VIDEO 3, DVD and SAT inputs.

For example, select “–VIDEO 1”. When you press DMPORT, the images from the component connected to the VIDEO 1 VIDEO IN jack through DIGITAL MEDIA PORT adapter will appear on the TV screen.

To return to the previous display

Press \leftarrow .

Notes

- Depending on the type of DIGITAL MEDIA PORT adapter, you can operate the connected component by using the remote. For details on remote button operation, see page 9.
- Be sure you have made the video connection from DIGITAL MEDIA PORT adapter to the receiver (page 74).
- Be sure you have connected the MONITOR VIDEO OUT jack of the receiver to the TV (page 74).
- Depending on the DIGITAL MEDIA PORT adapter, video output may not be possible.

Tip

When listening to MP3 or other compressed music using a portable audio source, you can enhance the sound. Press MUSIC repeatedly to select “PORTABLE” (page 61).

Naming inputs

You can enter a name of up to 8 characters for inputs and display it on the receiver's display. This is convenient for labeling the jacks with the names of the connected components.

1 Press one of the input buttons to select the input you want to create an index name for.

You can also use INPUT SELECTOR on the receiver.

2 Press RECEIVER.

The RECEIVER indicator lights up and receiver operation is activated.

3 Press MENU.

"1-LEVEL" appears on the display.

4 Press \uparrow/\downarrow repeatedly to select either "5-AUDIO" or "6-VIDEO".

5 Press $\left(\leftarrow\rightarrow\right)$ or \rightarrow to enter the menu.

6 Press \uparrow/\downarrow to select "NAME IN".

7 Press $\left(\leftarrow\rightarrow\right)$ or \rightarrow to enter the parameter.

The cursor flashes and you can select a character. Follow the procedure given in "To create an index name" (page 69).

Changing the display

You can check the sound field, etc., by changing the information on the display. Be sure to use the buttons on the receiver for this operation.

Press DISPLAY repeatedly.

Each time you press the button, the display changes cyclically as follows:

All inputs except the FM and AM band

Index name of the input^{a)} → Selected input
→ Sound field currently applied

FM and AM band

Program Service name^{b)} or preset station name^{a)} → Frequency → Program Type indication^{b)} → Radio Text indication^{b)} → Current Time indication (in 24-hour system mode)^{b)} → Sound field currently applied

^{a)} Index name appears only when you have assigned one to the input or preset station (page 68, 76).

Index name does not appear when only blank spaces have been entered, or it is the same as the input name.

^{b)} During RDS reception only (Models of area code CEL, CEK only) (page 69).

Note

Character or marks may not be displayed for some languages.

Using the Sleep Timer

You can set the receiver to turn off automatically at a specified time.

Press SLEEP repeatedly while the power is on.

Each time you press the button, the display changes cyclically as follows:

2-00-00 → 1-30-00 → 1-00-00 → 0-30-00
→ OFF

When sleep timer is activated, the display dims.

Note

If you press any buttons on the remote or receiver after the display dims, the display brightens up. After a while, the display dims again if no button is pressed.

Tip

To check the remaining time before the receiver turns off, press SLEEP. The remaining time appears on the display. If you press SLEEP again, the sleep timer will be canceled.

Recording using the receiver

Recording onto a CD-R

You can record onto a CD-R using the receiver. See the operating instructions supplied with your CD recorder.

- 1 Press one of the input buttons to select the playback component.**
You can also use INPUT SELECTOR on the receiver.
- 2 Prepare the playback component for playing.**
For example, tune to the radio station you want to record (page 65).
- 3 Prepare the recording component.**
Insert a blank CD-R into the CD recorder and adjust the recording level.
- 4 Start recording on the recording component, then start playback on the playback component.**

Note

Sound adjustments do not affect the signal output from the SA-CD/CD/CD-R OUT jacks.

Recording onto a recording media

You can record from a video component using the receiver. See the operating instructions supplied with your recording component.

1 Press one of the input buttons to select the playback component.

You can also use INPUT SELECTOR on the receiver.

2 Prepare the playback component for playing.

For example, insert the video tape you want to copy into the VCR.

3 Prepare the recording component.

Insert a blank video tape, etc. into the recording component (connected to VIDEO 1 OUT or VIDEO 2/BD OUT jack) for recording.

4 Start recording on the recording component, then start playback on the playback component.

Notes

- Some sources contain copy guards to prevent recording. In this case, you may not be able to record from the source.
- When DMPORT input is selected and you have assigned VIDEO 1 or VIDEO 2 input to DMPORT input, no video signals are output from the VIDEO 1 VIDEO OUT or VIDEO 2/BD VIDEO OUT jack.

Using the Remote

Programming the remote

You can program the remote to control non-Sony components by changing the code. Once the control signals have been memorized, you can use those components as part of your system.

Furthermore, you can also program the remote for Sony components that the remote is unable to control. Note that the remote can only control components that accept infrared wireless control signals.

1 Press RM SET UP.

The RM SET UP indicator slowly flashes.

2 Press the input button for the component you want to control.

For example, if you are going to control a CD player, press SA-CD/CD.

The RM SET UP indicator lights up.

3 Press the numeric buttons to enter the numeric code (or one of the codes if more than one code exists) corresponding to the component and the maker of the component you want to control (except TV).

See the tables on page 80–83 for information on the numeric code(s) corresponding to the component and the maker of the component (the first digit and the last two digits of the numeric code correspond to the category and the maker's code respectively).

4 Press ENTER.

Once the numeric code has been verified, the RM SET UP indicator slowly flashes twice and the remote automatically exits the programming mode.

5 Repeat steps 1 to 4 to control other components.

Notes

- The indicator turns off while a valid button is pressed.
- In step 2, if several input buttons are pressed, only the last pressed button is valid.
- In step 2, if you press TUNER, you can only program the button to control a tuner (page 83).
- In step 3, if an input button is pressed, the new input is selected and the programming procedure returns to the beginning of step 3.
- For the numeric codes, only the last three numbers entered are valid.

To program the remote to control a TV

1 Press RM SET UP.

The RM SET UP indicator slowly flashes.

2 Press TV.

3 Press the numeric buttons to enter the numeric code (or one of the codes if more than one code exists) for TV. For details, see page 81.

4 Press ENTER.

Once the numeric code has been verified, the RM SET UP indicator slowly flashes twice and the remote automatically exits the programming mode.

To cancel programming

Press RM SET UP during any step. The RM SET UP indicator flashes 5 times in quick succession. The remote automatically exits the programming mode.

To activate the input after programming

Press the programmed button to activate the input you want.

If programming is unsuccessful, check the following:

- If the indicator does not light up in step 1, the batteries are weak. Replace both batteries.
- If the indicator flashes 5 times in quick succession while entering the numeric code, an error has occurred. Start again from step 1.

To clear the memory of the remote

To clear all programmes, do the following to reset the remote to factory settings.

While holding down MASTER VOL –, press and hold I/⏻ and then press AV I/⏻.

The indicator flashes 3 times, then goes off.

The numeric codes corresponding to the component and the maker of the component

Use the numeric codes in the tables below to control non-Sony components and also Sony components that the remote is normally unable to control. Since the remote signal that a component accepts differs depending on the model and year of the component, more than one numeric code may be assigned to a component. If you fail to program your remote using one of the codes, try using other codes.

Notes

- The numeric codes are based on the latest information available for each brand. There is a chance, however, that your component will not respond to some or all of the codes.
- All of the input buttons on this remote may not be available when used with your particular component.

To control a CD player

Maker	Code(s)
SONY	101, 102, 103
DENON	104, 123
JVC	105, 106, 107
KENWOOD	108, 109, 110
MAGNAVOX	111, 116
MARANTZ	116
ONKYO	112, 113, 114
PANASONIC	115
PHILIPS	116
PIONEER	117
TECHNICS	115, 118, 119
YAMAHA	120, 121, 122

To control a DAT deck

Maker	Code(s)
SONY	203
PIONEER	219

To control an MD deck

Maker	Code(s)
SONY	301
DENON	302
JVC	303
KENWOOD	304

To control a tape deck

Maker	Code(s)
SONY	201, 202
DENON	204, 205
KENWOOD	206, 207, 208, 209
NAKAMICHI	210
PANASONIC	216
PHILIPS	211, 212
PIONEER	213, 214
TECHNICS	215, 216
YAMAHA	217, 218

To control an LD player

Maker	Code(s)
SONY	601, 602, 603
PIONEER	606

To control a video CD player

Maker	Code(s)
SONY	605

To control a VCR

Maker	Code(s)
SONY	701, 702, 703, 704, 705, 706
AIWA*	710, 750, 757, 758
AKAI	707, 708, 709, 759
BLAUPUNKT	740
EMERSON	711, 712, 713, 714, 715, 716, 750
FISHER	717, 718, 719, 720
GENERAL ELECTRIC (GE)	721, 722, 730
GOLDSTAR/LG	723, 753
GRUNDIG	724
HITACHI	722, 725, 729, 741
ITT/NOKIA	717
JVC	726, 727, 728, 736
MAGNAVOX	730, 731, 738
MITSUBISHI/MGA	732, 733, 734, 735
NEC	736
PANASONIC	729, 730, 737, 738, 739, 740
PHILIPS	729, 730, 731
PIONEER	729
RCA/PROSCAN	722, 729, 730, 731, 741, 747
SAMSUNG	742, 743, 744, 745
SANYO	717, 720, 746
SHARP	748, 749
TELEFUNKEN	751, 752
TOSHIBA	747, 756
ZENITH	754

* If an AIWA VCR does not work even though you enter the code for AIWA, enter the code for Sony instead.

To control a DVD player

Maker	Code(s)
SONY	401, 402, 403
BROKSONIC	424
DENON	405
HITACHI	416
JVC	415, 423
MITSUBISHI	419
ORITRON	417
PANASONIC	406, 408, 425
PHILIPS	407
PIONEER	409, 410
RCA	414
SAMSUNG	416, 422
TOSHIBA	404, 421
ZENITH	418, 420

To control a DVD recorder

Maker	Code(s)
SONY	403

To control a TV

Maker	Code(s)
SONY	501, 502
AIWA	536, 539, 501
AKAI	503
AOC	503
CENTURION	566
CORONADO	517
CURTIS-MATHES	503, 551, 566, 567
DAYTRON	517, 566
DAEWOO	504, 505, 506, 507, 515, 544
FISHER	508, 545
FUNAI	548
FUJITSU	528
GOLDSTAR/LG	503, 512, 515, 517, 534, 544, 556, 568
GRUNDIG	511, 533, 534
HITACHI	513, 514, 515, 544, 557, 503, 519, 517, 571
ITT/NOKIA	521, 522
J.C.PENNY	503, 510, 566
JVC	516, 552
KMC	517
MAGNAVOX	503, 518, 544, 515, 517, 566
MARANTZ	527
MITSUBISHI/MGA	503, 519, 527, 544, 566, 568
NEC	503, 520, 544, 554, 517, 540, 566
NORDMENDE	530, 558
NOKIA	521, 522, 573, 575
PANASONIC	509, 524, 553, 559, 572
PHILIPS	515, 518, 557, 570, 571
PHILCO	503, 504, 514, 517, 518
PIONEER	509, 525, 526, 540, 551, 555
PORTLAND	503
QUASAR	509, 535

Maker	Code(s)
RADIO SHACK	503, 510, 527, 565, 567
RCA/PROSCAN	510, 523, 529, 544, 503
SAMSUNG	503, 515, 531, 532, 534, 544, 556, 557, 517, 562, 563, 566, 569
SAMPO	566
SABA	547, 537, 549, 558, 530
SANYO	508, 545, 546, 560, 567
SCOTT	503, 566
SEARS	517, 510, 508, 503, 518, 551
SHARP	535, 550, 517, 561, 565
SYLVANIA	503, 518, 566
THOMSON	530, 537, 547, 549
TOSHIBA	535, 539, 540, 541, 551
TELEFUNKEN	537, 538, 547, 549, 558, 530
TEKNIKA	517, 518, 567
WARDS	503, 517, 566
YORK	566
ZENITH	542, 543, 567
GE	509, 510, 503, 544
LOEWE	515, 534, 556

To control a satellite tuner

Maker	Code(s)
SONY	801, 802, 803, 804, 824, 825, 865
AMSTRAD	845, 846
BskyB	862
GENERAL ELECTRIC (GE)	866
GRUNDIG	859, 860
HUMAX	846, 847
THOMSON	857, 861, 864
PACE	848, 849, 850, 852, 862, 863, 864
PANASONIC	818, 855
PHILIPS	856, 857, 858, 859, 860, 864, 874
NOKIA	851, 853, 854, 864
RCA/PROSCAN	866, 871
BITA/HITACHI	868
HUGHES	867
JVC/Echostar/Dish Network	873
MITSUBISHI	872
SAMSUNG	875
TOSHIBA	869, 870

To control a cable box

Maker	Code(s)
SONY	821, 822, 823
HAMLIN/REGAL	836, 837, 838, 839, 840
JERROLD/G.I./MOTOROLA	806, 807, 808, 809, 810, 811, 812, 813, 814, 819
JERROLD	830, 831
OAK	841, 842, 843
PANASONIC	816, 826, 832, 833, 834, 835
PHILIPS	830, 831
PIONEER	828, 829
RCA	805
SCIENTIFIC ATLANTA	815, 816, 817
TOCOM/PHILIPS	830, 831
ZENITH	826, 827

To control a tuner

Maker	Code(s)
SONY	002, 005

To control a Blu-ray disc recorder

Maker	Code(s)
SONY	310, 311, 312

To control a PSX

Maker	Code(s)
SONY	313, 314, 315

To control a DVD/VHS COMBO

Maker	Code(s)
SONY	411

To control a DVD/HDD COMBO

Maker	Code(s)
SONY	403

Additional Information

Glossary

■ Component video

A format for transmitting video signal information consisting of three separate signals: luminance Y, chrominance Pb, and chrominance Pr. High quality pictures, such as DVD video or HDTV pictures, are transmitted more faithfully. The three jacks are color-coded green, blue and red.

■ Composite video

A standard format for transmitting video signal information. The luminance signal Y and chrominance signal C are combined and transmitted together.

■ Dolby Digital

Digital audio encoding/decoding technology developed by Dolby Laboratories, Inc. It consists of front (left/right), center, surround (left/right) and sub woofer channels. It is a designated audio standard for DVD video and also known as 5.1 channel surround. Since surround information is recorded and reproduced in stereo, more realistic sound with fuller presence is delivered than with Dolby surround.

■ Dolby Digital Surround EX

Acoustic technology developed by Dolby Laboratories, Inc. Surround back information is matrixed into regular left and right surround channels so that the sound can be reproduced in 6.1 channel. Active scenes, especially, are recreated with a more dynamic and realistic sound field.

■ Dolby Pro Logic II

This technology converts 2 channel stereo recorded audio into 5.1 channel for playback. There is a MOVIE mode for movies and MUSIC mode for stereo sources such as music. Old movies encoded in the traditional stereo format can be enhanced with 5.1 channel surround sound.

■ Dolby Pro Logic IIx

Technology for 7.1 channel (or 6.1 channel) playback. Along with audio encoded in Dolby Digital Surround EX, 5.1 channel Dolby Digital encoded audio can be reproduced in 7.1 channel (or 6.1 channel). Furthermore, existing stereo recorded content can also be reproduced in 7.1 channel (or 6.1 channel).

■ Dolby Surround (Dolby Pro Logic)

Audio processing technology developed by Dolby Laboratories, Inc. Center and mono surround information is matrixed into two stereo channels. When reproduced, audio is decoded and output in 4 channel surround sound. This is the most common audio processing method for DVD video.

■ DTS 96/24

A high sound quality digital signal format. It records audio at a sampling frequency and bit rate of 96 kHz/24bit which is the highest possible for DVD video. The number of playback channels varies depending on the software.

■ DTS Digital Surround

Digital audio encoding/decoding technology for theaters developed by DTS, Inc. It compresses audio less than Dolby Digital, delivering a higher quality sound reproduction.

■ DTS-ES

Format for 6.1 channel playback with surround back information. There are two modes, "Discrete 6.1" which records all channels independently, and "Matrix 6.1" which matrixes surround back channel into surround left and surround right channels. It is ideal for playback of motion picture soundtracks.

■ DTS Neo:6

This technology converts 2 channel stereo recorded audio for 6.1 channel playback. There are two modes to select according to the playback source or your preference, CINEMA for movies, and MUSIC for stereo sources such as music.

■ HDMI (High-Definition Multimedia Interface)

HDMI is an interface that supports both video and audio on a single digital connection. The HDMI connection carries standard to high definition video signals and multi channel audio signals to audio/video components, such as HDMI equipped TVs, in digital form without degradation. The HDMI specification supports HDCP (High-bandwidth Digital Contents Protection), a copy protection technology that incorporates coding technology for digital video signals.

■ Sampling frequency

To convert analog audio to digital, analog data should be quantified. This process is called sampling, and the number of times per second the analog data is quantified is called the sampling frequency. A standard music CD stores data quantified at 44,100 times per second, which is expressed as a sampling frequency of 44.1 kHz. Generally speaking, a higher sampling frequency means better sound quality.

■ TSP (Time Stretched Pulse)

A TSP signal is a highly precise measuring signal that utilizes impulse energy, measuring a wide band, from low to high, in a short period.

The amount of energy used to measure signals is important to ensure measurement accuracy in a normal indoor environment. Using TSP signals makes it possible to measure signals effectively.

Precautions

On safety

Should any solid object or liquid fall into the cabinet, unplug the receiver and have it checked by qualified personnel before operating it any further.

On power sources

- Before operating the receiver, check that the operating voltage is identical with your local power supply.
The operating voltage is indicated on the nameplate on the back of the receiver.
- The unit is not disconnected from the AC power source (mains) as long as it is connected to the wall outlet, even if the unit itself has been turned off.
- If you are not going to use the receiver for a long time, be sure to disconnect the receiver from the wall outlet. To disconnect the AC power cord, grasp the plug itself; never pull the cord.
- The AC power cord must be changed only at a qualified service shop.

On heat buildup

Although the receiver heats up during operation, this is not a malfunction. If you continuously use this receiver at a large volume, the cabinet temperature of the top, side and bottom rises considerably. To avoid burning yourself, do not touch the cabinet.

On placement

- Place the receiver in a location with adequate ventilation to prevent heat buildup and prolong the life of the receiver.
- Do not place the receiver near heat sources, or in a place subject to direct sunlight, excessive dust, or mechanical shock.
- Do not place anything on top of the cabinet that might block the ventilation holes and cause malfunctions.
- Do not place the receiver near equipment such as a TV, VCR, or tape deck. (If the receiver is being used in combination with a TV, VCR, or tape deck, and is placed too close to that equipment, noise may result, and picture quality may suffer. This is especially likely when using an indoor antenna. Therefore, we recommend using an outdoor antenna.)
- Use caution when placing the receiver on surfaces that have been specially treated (with wax, oil, polish, etc.) as staining or discoloration of the surface may result.

On operation

Before connecting other components, be sure to turn off and unplug the receiver.

On cleaning

Clean the cabinet, panel, and controls with a soft cloth slightly moistened with a mild detergent solution. Do not use any type of abrasive pad, scouring powder, or solvent, such as alcohol or benzine.

If you have any questions or problems concerning your receiver, please consult your nearest Sony dealer.

Troubleshooting

If you experience any of the following difficulties while using the receiver, use this troubleshooting guide to help you remedy the problem.

Audio

There is no sound, no matter which component is selected, or only a very low-level sound is heard.

- Check that the speakers and components are connected securely.
- Check that both the receiver and all components are turned on.
- Check that MASTER VOLUME is not set to “VOL MIN”.
- Check that the SPEAKERS (OFF/A/B/A+B) is not set to off (page 33).
- Check that headphones are not connected.
- Press MUTING to cancel the muting function.
- Check that you have selected the correct component with the input buttons (page 40).
- The protective device on the receiver has been activated. Turn off the receiver, eliminate the short-circuit problem, and turn on the power again.

There is no sound from a specific component.

- Check that the component is connected correctly to the audio input jacks for that component.
- Check that the cord(s) used for the connection is (are) fully inserted into the jacks on both the receiver and the component.

There is no sound from one of the front speakers.

- Connect a pair of headphones to the PHONES jack to verify that sound is output from the headphones. If only one channel is output from the headphones, the component may not be connected to the receiver correctly. Check that all the cords are fully inserted into the jacks on both the receiver and the component. If both channels are output from the headphones, the front speaker may not be connected to the receiver correctly. Check the connection of the front speaker which is not outputting any sound.
- Make sure you have connected to both the L and R jacks of an analog component, and not only to either the L or R jack. Use an audio cord (not supplied).

There is no sound from analog 2 channel sources.

- Check that the INPUT MODE is not set to “COAX IN”, “OPT IN” or “HDMI IN” for the selected input (page 71).

There is no sound from digital sources (from COAXIAL or OPTICAL input jack).

- Check that the INPUT MODE is not set to “ANALOG” or “HDMI IN” (page 71).
- Check that the ANALOG DIRECT function is not selected.
- Check that the DIGITAL ASSIGN function is not used to reassign the audio input of another source to the selected input (page 72).

There is pop noise from a specific component connected to this receiver when you turn on the component.

- Check that the INPUT MODE is not set to “AUTO IN” for the selected input (page 71).

The source sound input from the HDMI jack on the receiver is not output from the receiver or TV speaker.

- Check the setting of HDMI AUDIO in the VIDEO menu (page 54).
- Check the HDMI connection.
- The sound is not output when the amplifier menus are displayed on the TV screen. In this case, set “OSD” in VIDEO menu to “OSD OFF”.
- You cannot listen to the Super Audio CD by connecting HDMI.
- Depending on the playback component, you may need to set up the component. Refer to the operating instructions supplied with each component.

The left and right sounds are unbalanced or reversed.

- Check that the speakers and components are connected correctly and securely.
- Adjust the balance parameters using the LEVEL menu.

There is severe hum or noise.

- Check that the speakers and components are connected securely.
- Check that the connecting cords are away from a transformer or motor, and at least 3 meters away from a TV set or fluorescent light.
- Move your audio components away from the TV.
- The plugs and jacks are dirty. Wipe them with a cloth slightly moistened with alcohol.

There is no sound, or only a very low-level sound is heard from the center/surround/surround back speakers.

- Select a CINEMA STUDIO EX mode (page 62).
- Adjust the speaker level (page 39).
- Make sure the center/surround speakers are set to either “SMALL” or “LARGE” (page 47).
- Make sure the surround back speakers are set to “SINGLE” or “DUAL” (page 47).

continued

There is no sound from the surround back speaker.

- Some discs have no Dolby Digital Surround EX flag even though the packages have Dolby Digital Surround EX logos. In this case, select “SB ON” (page 51).

There is no sound from the sub woofer.

- Check that the sub woofer is connected correctly and securely.
- Make sure you have turned on your sub woofer.
- Make sure the sub woofer is set to “YES” (page 47).
- Depending on the selected sound field, no sound output from the sub woofer.
- When all speakers are set to “LARGE” and “NEO6 CIN” or “NEO MUS” is selected, there is no sound from the sub woofer.

The surround effect cannot be obtained.

- Make sure the sound field function is on (press MOVIE or MUSIC).
- Sound fields do not function for signals with a sampling frequency of more than 48 kHz.

Dolby Digital or DTS multi channel sound is not reproduced.

- Check that the DVD, etc. you are playing is recorded in Dolby Digital or DTS format.
- When connecting the DVD player, etc., to the digital input jacks of this receiver, check the audio setting (the settings for the audio output) of the connected component.

Recording cannot be carried out.

- Check that the components are connected correctly.
- Select the source component using the input buttons (page 40).

The MULTI CHANNEL DECODING lamp does not light up in blue.

- Check that the playback component is connected to a digital jack and the input is selected properly on this receiver.
- Check whether the input source of the software being played back corresponds to the multi channel format.
- Check whether the setup on the playback component is set to multi channel sound.
- Check whether the digital audio output of selected input is not assigned to another component input using DIGITAL ASSIGN function (page 72).

Video

There is no picture or an unclear picture appears on the TV screen.

- Select the appropriate input using the input buttons.
- Set your TV to the appropriate input mode.
- Move your audio components away from the TV.
- Assign the composite video input to DMPORT input correctly.
- Depending on the DIGITAL MEDIA PORT adapter, video output may not be possible.

The source image input to the HDMI jack on the receiver is not output from the TV.

- Check the HDMI connection.
- Depending on the playback component, you may need to set up the component. Refer to the operating instructions supplied with each component.

Recording cannot be carried out.

- Check that the components are connected correctly.
 - Select the source component using the input buttons (page 40).
-

Tuner

The FM reception is poor.

- Use a 75-ohm coaxial cable (not supplied) to connect the receiver to an outdoor FM antenna as shown below. If you connect the receiver to an outdoor antenna, ground it against lightning. To prevent a gas explosion, do not connect the ground wire to a gas pipe.

Outdoor FM antenna

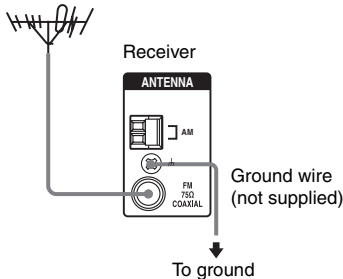

Radio stations cannot be tuned in.

- Check that the antennas are connected securely. Adjust the antennas and connect an external antenna, if necessary.
- The signal strength of the stations is too weak (when tuning in with automatic tuning). Use direct tuning.
- Make sure you set the tuning interval correctly (when tuning in AM stations with direct tuning).
- No stations have been preset or the preset stations have been cleared (when tuning by scanning preset stations). Preset the stations (page 67).
- Press DISPLAY repeatedly on the receiver so that the frequency appears on the display.

RDS does not work.*

- Make sure that you are tuned to an FM RDS station.
- Select a stronger FM station.

The RDS information that you want does not appear.*

- Contact the radio station and find out whether they actually provide the service in question. If so, the service may be temporarily out of order.

Remote commander

The remote does not function.

- Point the remote at the remote sensor on the receiver.
- Remove any obstacles in the path between the remote and the receiver.
- Replace all the batteries in the remote with new ones, if they are weak.
- Make sure you select the correct input on the remote.
- When you operate a programmed non-Sony component, the remote may not function properly depending on the model and the maker of the component.

* Models of area code CEL, CEK only.

Error messages

If there is a malfunction, the display shows a message. You can check the condition of the system by the message. Refer to the following table to solve the problem. If any problem persists, consult your nearest Sony dealer. If an error message appears while you perform Auto Calibration, see “When error codes appear” (page 36) to solve the problem.

PROTECT

Irregular current is output from the speakers. The receiver will automatically turn off after a few seconds. Check the speaker connection and turn on the power again.

If you are unable to remedy the problem using the troubleshooting guide

Clearing the receiver's memory may remedy the problem (page 32). However, note that all memorized settings will be reset to their factory settings and you will have to readjust all settings on the receiver.

If the problem persists

Consult your nearest Sony dealer. Note that if service personnel changes some parts during repair, these parts may be retained.

Reference sections for clearing the receiver's memory

To clear	See
All memorized settings	page 32
Customized sound fields	page 65

Specifications

Amplifier section

Models of area code CEL, CEK
Minimum RMS Output Power
(8 ohms, 20 Hz - 20 kHz, THD 0.09%)
90 W + 90 W¹⁾

Stereo Mode Output Power
(8 ohms, 1 kHz, THD 1%)
100 W + 100 W¹⁾

Surround Mode Output Power²⁾
(8 ohms, 1 kHz, THD 10%)
140 W per channel¹⁾

Models of area code E2, TW
Minimum RMS Output Power
(8 ohms, 20 Hz - 20 kHz, THD 0.09%)
85 W + 85 W¹⁾

Stereo Mode Output Power
(8 ohms, 1 kHz, THD 1%)
100 W + 100 W¹⁾

Surround Mode Output Power²⁾
(8 ohms, 1 kHz, THD 10%)
130 W per channel¹⁾

Models of area code KR
Minimum RMS Output Power
(8 ohms, 20 Hz - 20 kHz, THD 0.09%)
90 W + 90 W¹⁾,
80 W + 80 W³⁾

Stereo Mode Output Power
(8 ohms, 1 kHz, THD 1%)
100 W + 100 W¹⁾,
90 W + 90 W³⁾

Surround Mode Output Power²⁾
(8 ohms, 1 kHz, THD 10%)
140 W per channel¹⁾,
120 W per channel³⁾

¹⁾Measured under the following conditions:

Area code	Power requirements
CEL, CEK, KR	230 V AC, 50 Hz
E2	240 V AC, 50 Hz
TW	110 V AC, 60 Hz

2) Reference power output for front, center, surround and surround back speakers. Depending on the sound field settings and the source, there may be no sound output.

3) Measured under the following conditions:
220 V AC, 60 Hz

Frequency response

Analog 10 Hz – 70 kHz,
+0.5/-2 dB (with sound
field and equalizer
bypassed)

Input

Analog Sensitivity: 500 mV/
50 kohms
S/N⁴⁾: 96 dB
(A, 500 mV⁵⁾)

Digital (Coaxial) Impedance: 75 ohms
S/N: 100 dB
(A, 20 kHz LPF)

Digital (Optical) S/N: 100 dB
(A, 20 kHz LPF)

Output (Analog)

AUDIO OUT Voltage: 500 mV/
10 kohms

SUB WOOFER Voltage: 2 V/1 kohm

Equalizer

Gain levels ±10 dB, 0.5 dB step

4) INPUT SHORT (with sound field and equalizer bypassed).

5) Weighted network, input level.

FM tuner section

Tuning range 87.5 – 108.0 MHz

Antenna FM wire antenna

Antenna terminals 75 ohms, unbalanced

Intermediate frequency

10.7 MHz

AM tuner section

Tuning range

Area code	Tuning scale	
	10 kHz step	9 kHz step
CEL, CEK, TW, KR	–	531–1,602 kHz
E2	530–1,610 kHz ⁶⁾	531–1,602 kHz ⁶⁾

Antenna Loop antenna

Intermediate frequency

450 kHz

6) You can change the AM tuning scale to 9 kHz or 10 kHz. After tuning in any AM station, turn off the receiver. While holding down TUNING MODE, press I/⏪. All preset stations will be erased when you change the tuning scale. To reset the scale to 10 kHz (or 9 kHz), repeat the procedure.

Video section

Inputs/Outputs

Video: 1 Vp-p, 75 ohms

COMPONENT VIDEO:

Y: 1 Vp-p, 75 ohms

PB/CB: 0.7 Vp-p, 75 ohms

Pr/Cr: 0.7 Vp-p, 75 ohms

80 MHz HD Pass Through

General

Power requirements

Area code	Power requirements
CEL, CEK	230 V AC, 50/60 Hz
E2	120/220/240 V AC, 50/60 Hz
TW	110 V AC, 60 Hz
KR	220–230 V AC, 50/60 Hz

Power output (DIGITAL MEDIA PORT)

DC OUT: 5V, 700 mA

Power consumption

Area code	Power consumption
CEL, CEK, KR	230 W
E2	270 W
TW	650 W

Power consumption (during standby mode)

0.3 W (When
“CONTROL” in VIDEO
menu is set to “CTRL
OFF”.)

AC outlet (Models of area code E2 only)

1 switched, 100 W/
0.4 A MAX

Dimensions (width/height/depth) (Approx.)

430 × 157.5 × 351.5 mm
including projecting parts
and controls

Mass (Approx.)

Models of area code CEL, CEK, KR

10.6 kg

Models of area code E2, TW

11.2 kg

Supplied accessories

FM wire antenna (1)

AM loop antenna (1)

Remote commander RM-AAP017 (1)

R6 (size-AA) batteries (2)

Optimizer microphone ECM-AC2 (1)

For details on the area code of the component you are using, see page 2.
--

Design and specifications are subject to change without notice.

Index

Numerics

- 2CH STEREO 64
- 5.1 channel 14
- 7.1 channel 14

A

- AUTO CALIBRATION 33
- AUTO FORMAT DIRECT (A.F.D.) 59

B

- Blu-ray disc player
 - connecting 20

C

- CD player
 - connecting 17, 18
 - playback 42
- CD recorder
 - connecting 17, 18

D

- DIGITAL ASSIGN 72
- Digital Cinema Sound (DCS) 63
- DIGITAL MEDIA PORT
 - connecting 74
 - input 40
 - video assign 75
- Dolby Digital 83
- DTS 84
- DVD player
 - connecting 24
 - playback 43
- DVD recorder
 - connecting 25

E

- Error messages 89

H

- HDMI
 - connecting 20

I

- Initial setup 32
- INPUT MODE 71

M

- MD deck
 - connecting 18
- Menu
 - A. CAL 38
 - AUDIO 53
 - EQ 50
 - LEVEL 49
 - SUR 50
 - SYSTEM 55
 - TUNER 52
 - VIDEO 54
- Muting 41

N

- Naming 68, 76

R

- RDS 69
- Recording
 - onto a CD-R 77
 - onto a recording media 78
- Remote commander 9

S

- Satellite tuner/Set-top box
 - connecting 26
- Selecting
 - component 40
 - sound field 61
 - speaker system 33
- Sleep Timer 77
- Sound fields
 - resetting 65
 - selecting 61
- Speakers
 - connecting 15
 - installing 14
- Super Audio CD player
 - connecting 17, 18
 - playback 42
- SUR BACK DECODING 51

T

- Tape deck
 - connecting 18
- TEST TONE 39
- Tuner
 - connecting 30
- Tuning
 - automatically 65
 - directly 66
 - to preset stations 68
- TV
 - connecting 22

V

- VCR
 - connecting 27
- Video game
 - connecting 27



* 3 0 9 4 4 3 0 3 1 * (1)

Free Manuals Download Website

<http://myh66.com>

<http://usermanuals.us>

<http://www.somanuals.com>

<http://www.4manuals.cc>

<http://www.manual-lib.com>

<http://www.404manual.com>

<http://www.luxmanual.com>

<http://aubethermostatmanual.com>

Golf course search by state

<http://golfingnear.com>

Email search by domain

<http://emailbydomain.com>

Auto manuals search

<http://auto.somanuals.com>

TV manuals search

<http://tv.somanuals.com>