

**SONY®**

HD DIGITAL VIDEOCASSETTE PLAYER

**HDW-M2100**

**HDW-M2100P**



OPERATION MANUAL English  
1st Edition (Revised 5)

## **WARNING**

**To prevent fire or shock hazard, do not expose the unit to rain or moisture.**

**To avoid electrical shock, do not open the cabinet. Refer servicing to qualified personnel only.**

**THIS APPARATUS MUST BE EARTHED.**

## **AVERTISSEMENT**

**Afin d'éviter tout risque d'incendie ou d'électrocution, ne pas exposer cet appareil à la pluie ou à l'humidité.**

**Afin d'écarter tout risque d'électrocution, garder le coffret fermé. Ne confier l'entretien de l'appareil qu'à un personnel qualifié.**

**CET APPAREIL DOIT ÊTRE RELIÉ À LA TERRE.**

## **WARNUNG**

**Um Feuergefahr und die Gefahr eines elektrischen Schlages zu vermeiden, darf das Gerät weder Regen noch Feuchtigkeit ausgesetzt werden.**

**Um einen elektrischen Schlag zu vermeiden, darf das Gehäuse nicht geöffnet werden. Überlassen Sie Wartungsarbeiten stets nur qualifiziertem Fachpersonal.**

**DIESES GERÄT MUSS GEERDET WERDEN.**



This symbol is intended to alert the user to the presence of important operating and maintenance (servicing) instructions in the literature accompanying the appliance.

### **For the customers in the U.S.A.**

This equipment has been tested and found to comply with the limits for a Class A digital device, pursuant to Part 15 of the FCC Rules. These limits are designed to provide reasonable protection against harmful interference when the equipment is operated in a commercial environment. This equipment generates, uses, and can radiate radio frequency energy and, if not installed and used in accordance with the instruction manual, may cause harmful interference to radio communications. Operation of this equipment in a residential area is likely to cause harmful interference in which case the user will be required to correct the interference at his own expense.

You are cautioned that any changes or modifications not expressly approved in this manual could void your authority to operate this equipment.

The shielded interface cable recommended in this manual must be used with this equipment in order to comply with the limits for a digital device pursuant to Subpart B of Part 15 of FCC Rules.

### **WARNING: THIS WARNING IS APPLICABLE FOR USA ONLY.**

If used in USA, use the UL LISTED power cord specified below.

#### **DO NOT USE ANY OTHER POWER CORD.**

Plug Cap Parallel blade with ground pin  
(NEMA 5-15P Configuration)

Cord Type SJT, three 16 or 18 AWG  
wires

Length Less than 2.5 m (8 ft 3 in)

Rating Minimum 10 A, 125 V

Using this unit at a voltage other than 120V may require the use of a different line cord or attachment plug, or both.

To reduce the risk of fire or electrical shock, refer servicing to qualified service personnel.

**WARNING: THIS WARNING IS APPLICABLE FOR OTHER COUNTRIES.**

1. Use the approved Power Cord (3-core mains)/Appliance Connector/Plug with earthing-contacts that conforms to the safety regulations of each country if applicable.
  2. Use the Power Cord (3-core mains lead)/Plug conforming to the following ratings, which meets power supply voltage of each country.
- Rating: 10A or more

**AVERTISSEMENT: CET AVERTISSEMENT EST VALABLE POUR LES AUTRES PAYS.**

1. Utilisez le cordon (conducteur 3 âmes)/connecteur d'appareil et la fiche d'alimentation avec prise de terre, approuvés et conformes à la réglementation relative à la sécurité, adoptée par chaque pays.
  2. Utilisez le cordon (conducteur 3 âmes) et la fiche d'alimentation correspondant aux caractéristiques suivantes, en fonction de la tension d'alimentation secteur de chaque pays.
- Ampérage: 10A ou plus

**WARNUNG: Die folgenden Warnungsangaben gelten für das Modell für andere Länder.**

1. Das Netzkabel (dreifach)/der Gerätestecker/der Netzstecker muss einen Erdungskontakt besitzen und den Sicherheitsbestimmungen Ihres Landes genügen.
  2. Das Netzkabel (dreifach) muss je nach der Netzspannung Ihres Landes für folgende Spannungen und Ströme ausgelegt sein.
- Stromstärke 10A oder mehr

**For the customers in Europe**

This product with the CE marking complies with both the EMC Directive (89/336/EEC) and the Low Voltage Directive (73/23/EEC) issued by the Commission of the European Community.

Compliance with these directives implies conformity to the following European standards:

- EN60950: Product Safety
- EN55103-1: Electromagnetic Interference (Emission)
- EN55103-2: Electromagnetic Susceptibility (Immunity)

This product is intended for use in the following Electromagnetic Environment(s):

E1 (residential), E2 (commercial and light industrial), E3 (urban outdoors) and E4 (controlled EMC environment, ex. TV studio).

**Pour les clients européens**

Ce produit portant la marque CE est conforme à la fois à la Directive sur la compatibilité électromagnétique (EMC) (89/336/CEE) et à la Directive sur les basses tensions (73/23/CEE) émises par la Commission de la Communauté européenne.

La conformité à ces directives implique la conformité aux normes européennes suivantes:

- EN60950: Sécurité des produits
- EN55103-1: Interférences électromagnétiques (émission)
- EN55103-2: Sensibilité électromagnétique (immunité)

Ce produit est prévu pour être utilisé dans les environnements électromagnétiques suivants:

E1 (résidentiel), E2 (commercial et industrie légère), E3 (urbain extérieur) et E4 (environnement EMC contrôlé ex. studio de télévision).

**Für Kunden in Europa**

Dieses Produkt besitzt die CE-Kennzeichnung und erfüllt die EMV-Richtlinie (89/336/EWG) sowie die Niederspannungsrichtlinie (73/23/EWG) der EG-Kommission.

Angewandte Normen:

- EN60950: Sicherheitsbestimmungen
- EN55103-1: Elektromagnetische Verträglichkeit (Störaussendung)
- EN55103-2: Elektromagnetische Verträglichkeit (Störfestigkeit),

für die folgenden elektromagnetischen Umgebungen:

E1 (Wohnbereich), E2 (kommerzieller und in beschränktem Maße industrieller Bereich), E3 (Stadtbereich im Freien) und E4 (kontrollierter EMV-Bereich, z.B. Fernsehstudio).

# Table of Contents

<b>Chapter 1 Overview</b>	<b>1-1 Features ..... 1-1</b> <b>1-2 Example System Configuration ..... 1-3</b>
<b>Chapter 2 Location and Function of Parts</b>	<b>2-1 Control Panels ..... 2-1</b> 2-1-1 Upper Control Panel ..... 2-2 2-1-2 Lower Control Panel ..... 2-3 2-1-3 Switch Panel ..... 2-11 <b>2-2 Connector Panel ..... 2-13</b>
<b>Chapter 3 Preparations</b>	<b>3-1 Connections to External Devices ..... 3-1</b> 3-1-1 Connections to Digital Devices ..... 3-1 3-1-2 Connecting Reference Signals ..... 3-2 <b>3-2 Setup ..... 3-3</b> <b>3-3 Superimposed Character Information ..... 3-4</b> <b>3-4 Cassettes ..... 3-6</b> 3-4-1 Cassette Types ..... 3-6 3-4-2 Inserting and Ejecting Cassettes ..... 3-6 3-4-3 Preventing Accidental Recording of Shot Marks ..... 3-7 <b>3-5 Using a Memory Stick ..... 3-8</b> 3-5-1 Notes on Memory Stick ..... 3-8
<b>Chapter 4 Playback</b>	<b>4-1 Playback ..... 4-1</b> 4-1-1 Preparations for Playback ..... 4-1 4-1-2 Playback Procedures ..... 4-2 4-1-3 Dynamic Motion Control (DMC) Playback ..... 4-6
<b>Chapter 5 Shot Mark Function</b>	<b>5-1 Overview ..... 5-1</b> <b>5-2 Shot Mark Operation Menu ..... 5-2</b> <b>5-3 Shot Mark Operations ..... 5-3</b> 5-3-1 Reading Shot Marks ..... 5-3 5-3-2 Writing Post Marks ..... 5-3 5-3-3 Shot Mark List Operations ..... 5-4 5-3-4 Cuing Up to Shot Marks ..... 5-6 5-3-5 Reading In Shot Data ..... 5-6 5-3-6 Sorting Shot Marks ..... 5-8
<b>Chapter 6 Tele-File</b>	<b>6-1 Overview of Tele-File Functions ..... 6-1</b> <b>6-2 Opening the Tele-File Menu ..... 6-2</b> <b>6-3 Tele-File Menu ..... 6-3</b> 6-3-1 Clip Data Display ..... 6-3 6-3-2 Preroll and Cue Up Using Clip Data ..... 6-6 6-3-3 Modifying Clip Data ..... 6-7 6-3-4 Undo/Resume Functions ..... 6-10 6-3-5 Displaying and Modifying Attribute Data ..... 6-11

# Table of Contents

---

<b>Chapter 7</b> <b>UMID Functions</b>	<b>7-1 Overview of UMID Functions ..... 7-1</b> <b>7-2 UMID Output and Display ..... 7-2</b> 7-2-1 UMID Output Settings ..... 7-2 7-2-2 UMID Display ..... 7-2
<b>Chapter 8</b> <b>Function Menu</b>	<b>8-1 Overview ..... 8-1</b> 8-1-1 Function Menu Configuration ..... 8-1 8-1-2 Using the Function Menu ..... 8-2 <b>8-2 Function Menu Item List ..... 8-3</b>
<b>Chapter 9</b> <b>Setup Menus</b>	<b>9-1 Setup Menu Configuration ..... 9-1</b> <b>9-2 Setup Menu Operations ..... 9-2</b> <b>9-3 Items in the Basic Setup Menu ..... 9-7</b> <b>9-4 Items in the Extended Setup Menu ..... 9-10</b>
<b>Chapter 10</b> <b>Maintenance and Inspection</b>	<b>10-1 Removing a Cassette When Tape Slack ..... 10-1</b> <b>10-2 Head Cleaning ..... 10-1</b> <b>10-3 Error Messages ..... 10-2</b> <b>10-4 Moisture Condensation ..... 10-4</b> <b>10-5 Regular Checks ..... 10-5</b> 10-5-1 Digital Hours Meter ..... 10-5 10-5-2 Maintenance Timings ..... 10-6
<b>Appendix</b>	<b>Specifications ..... A-1</b> <b>Index ..... I-1</b>

# 1-1 Features

The HDW-M2100/M2100P is a high-definition (HD) digital videocassette player based on the HDCAM format.

This unit uses large scale integrated circuits for signal processing, and has a simple internal construction, allowing it to provide functionality at least equivalent to a conventional VTR in a compact (4U size), lightweight, and low power consumption design.

In addition to HDCAM format playback, the unit can also play back tapes recorded in the Digital Betacam, MPEG IMX, Betacam SX, and analog Betacam formats.

## HDCAM format

The HDCAM format uses the same 12.65-mm width tape as the conventional Betacam series. It provides high definition images, offering up to two hours of recording. For video signal compression, prefiltration and coefficient recording technologies are used.

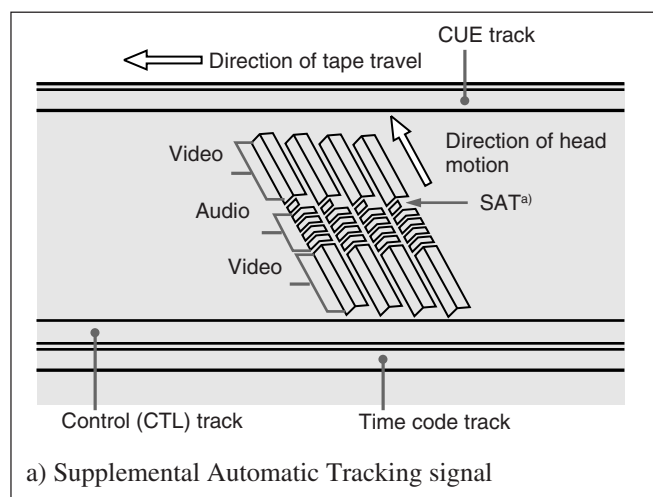

## High-performance heads and compatibility playback functions

The newly developed high-performance heads and dynamic tracking (DT) technology provide high-density playback in narrow tracks with high reliability. In addition to HDCAM playback heads, the unit is equipped with Betacam SX playback heads and analog Betacam DT heads, for playback compatibility with existing recording formats. The VTR automatically detects the recording format of tapes when they are loaded, so that no menu settings need to be made when changing formats.

## High-precision digital signal processing and range of interfaces

The digital signal processing uses HD 4:2:2 component video signals complying with SMPTE 292M, which are converted into parallel data and then compressed into HDCAM format.

The audio signals are based on AES/EBU format, and are subjected to digital signal processing without being compressed.

The unit is equipped with a high definition to standard definition (HD to SD) downward converter, and has the following interfaces as standard equipment, for ease of connection to different external devices.

- SD analog composite signal output
- SD analog component signal output
- Analog audio signal input/output (4 channels)
- HDSDI SMPTE 292M input/output (HD digital video/audio, 4 channels)
- SDI SMPTE 259M output (component digital video/audio, 4 channels)
- AES/EBU serial digital audio input/output (4 channels)
- SDTI SMPTE 305M input/output (HDCAM video/audio data) (option)
- Time code input/output
- CUE audio output

## High quality four-channel audio

High quality 20 bit/48 kHz AES/EBU digital audio is supported. There are four digital audio input/output channels, and four analog audio input/output channels.

## Playback of SDTI compressed data (optional)

This unit can be fitted with SDTI input/output complying with SMPTE 305M, and can therefore be used for transferring HDCAM data, audio data, metadata, and so on to a VTR or nonlinear device via an SDTI interface.

## Multifunction control panel

While built in a compact 4U size, this unit has a front panel which provides a wide range of functions while maintaining existing operability.

# 1-1 Features

---

---

## Basic operation buttons and jog/shuttle dial

The basic buttons and jog/shuttle dial for VTR and editing operations are provided in the conventional VTR layout, ensuring continuity with conventional operating panels.

---

## Time data display

This can be selected to display a CTL counter value, time code value, or time code user bits. It can also display edit points and edit durations.

---

## Menu-based control interface

The time data/menu display shows not only various values and settings, but also the pages of a menu system for commonly used functions. You can use the function keys and MULTI CONTROL knob to easily change settings.

Other operation settings, including interfacing with external devices, can be set from the control panel by the same type of setup menu system as on a conventional VTR.

---

## High quality variable speed playback and digital jog sound function

In HDCAM format playback, the dedicated playback DT heads allow smooth, noiseless playback. During Betacam SX playback, noiseless playback is achieved through unique multihead playback technology.

In slow motion operation, the digital jog sound function provides the same ease of operation as for a conventional analog VTR.

---

## DMC editing

This allows automatic playback with a varying speed memorized beforehand for the desired segment.

---

## Downward converter function

The unit has an HD-to-SD downward converter function, and can output standard definition SDI, analog component and analog composite signals even while playing back an HDCAM format tape.

---

## Upward converter function

The unit features a standard definition to high definition (SD-to-HD) upward converter as standard equipment. This allows high-quality HD signals to be output even when playing back tapes recorded in formats other than HDCAM.

---

## Tele-File functions

Tele-File enables data writing/reading between cassettes with memory labels and VTRs. It increases the efficiency of operations such as cuing up and playback, and source data management.

---

## Remote control function

This unit can be controlled from an external remote controller or editor through an interface complying with RS-422A (serial 9-pin). Since two remote control connectors are provided, you can also control a number of VTRs simultaneously.

Additionally, a parallel (50-pin) interface is also fitted as standard, supporting easy external control through the parallel interface.

---

## Rack mounting

Using the optional RMM-131 Rack Mount Adaptor, you can mount the unit in a standard EIA 19-inch rack.

*For details of rack mounting, refer to the Installation Manual.*

# 1-2 Example System Configuration

The following conceptual diagram shows an example of use.

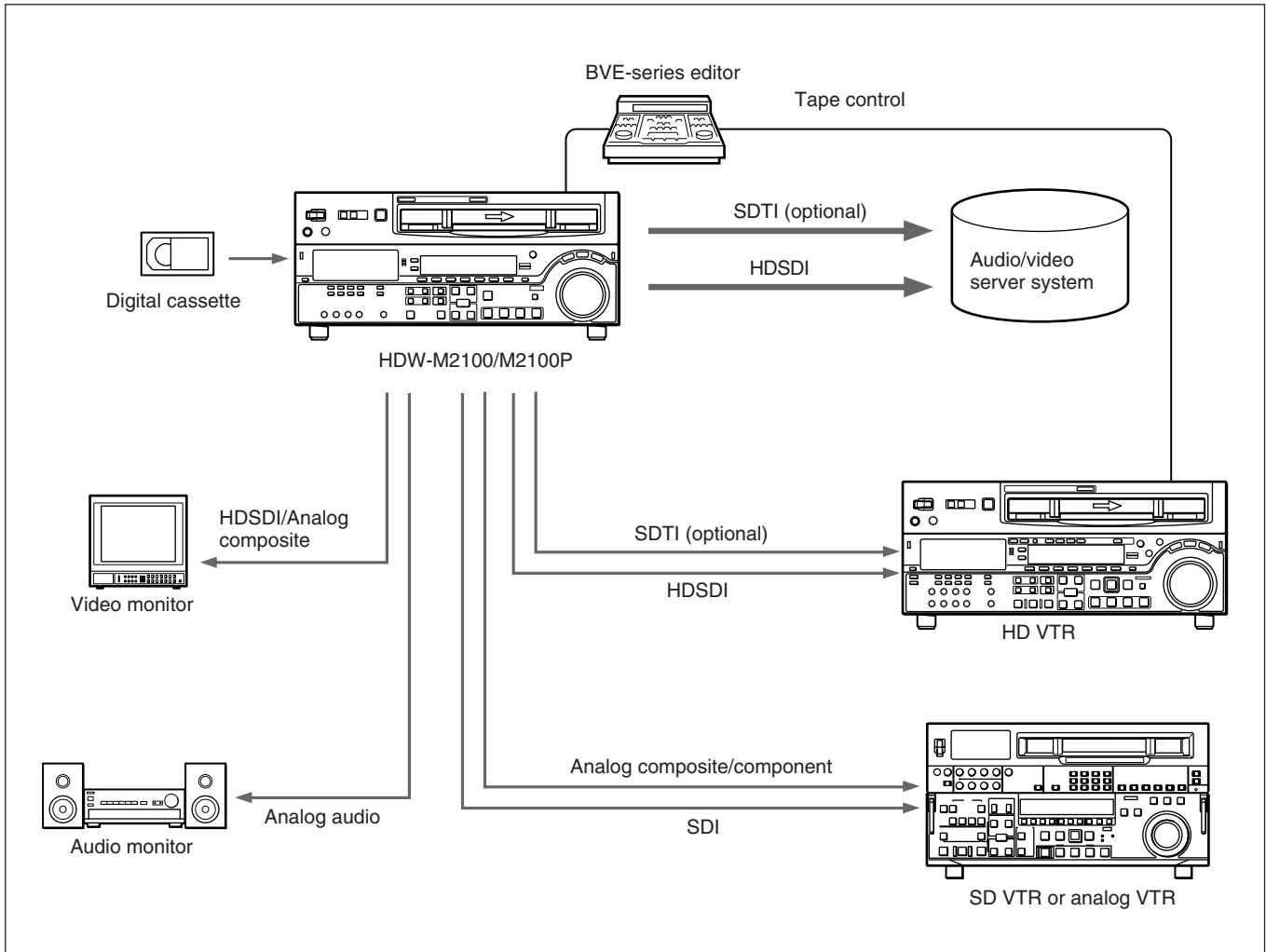



## 2-1 Control Panels

There are three control panels, as follows:

- Upper control panel
- Lower control panel
- Switch panel

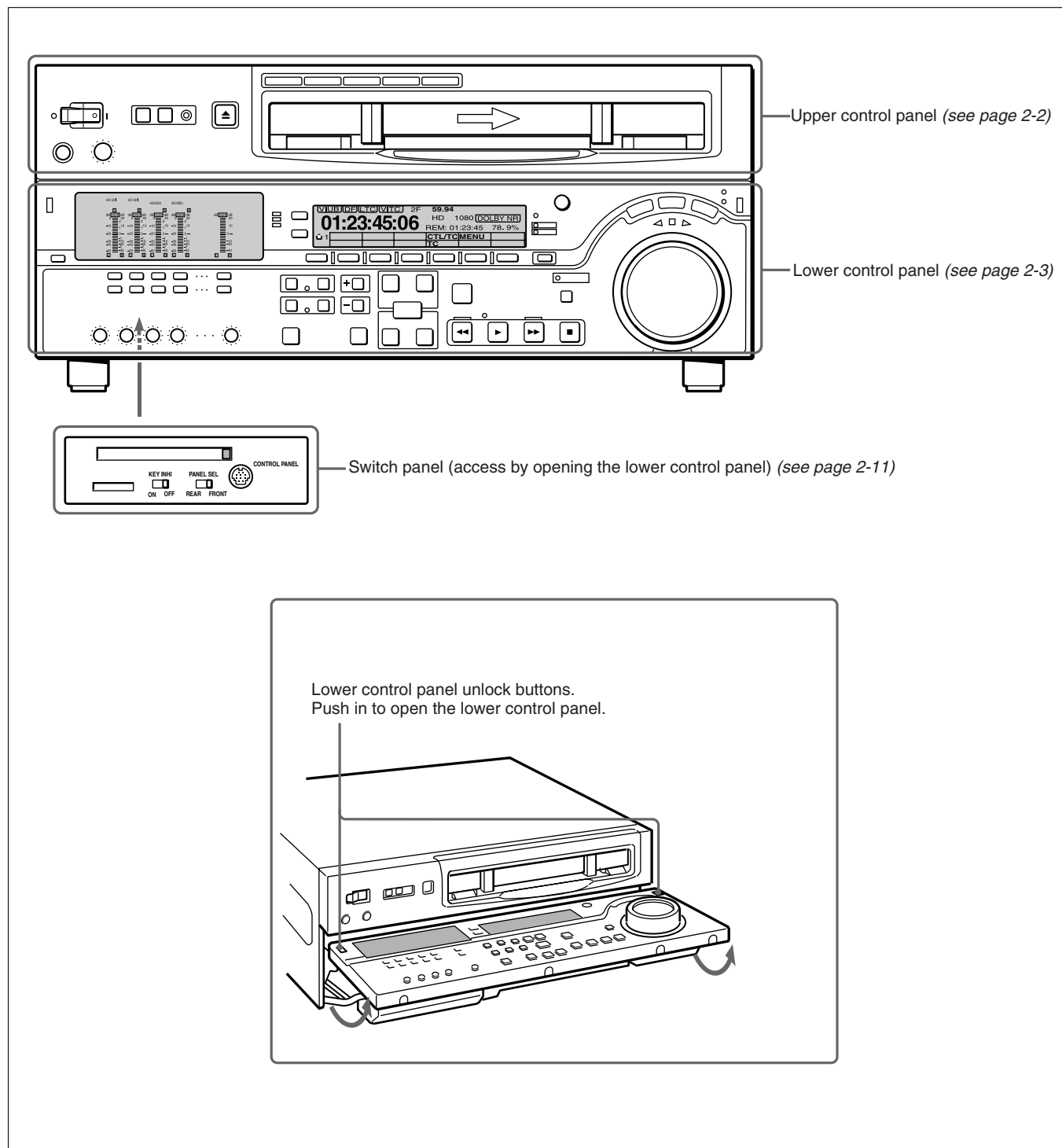

## 2-1 Control Panels

### 2-1-1 Upper Control Panel

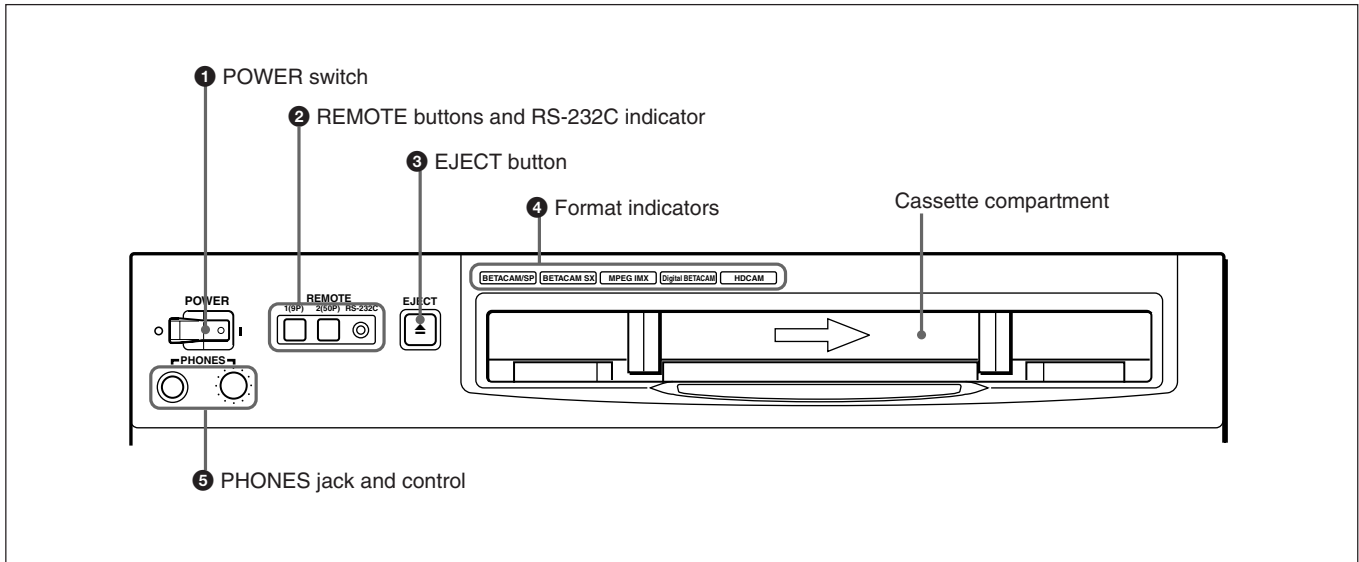

#### 1 POWER switch

Pressing the 'I' side of the switch powers the unit on. When the unit is powered on, the audio setting display section (*see page 2-4*) and the time data/menu display section (*see page 2-6*) light.

#### 2 REMOTE buttons and RS-232C indicator

Press the 1 (9P) button or 2 (50P) button to select the device controlling this unit.

**1(9P):** This unit is controlled by the device connected to the REMOTE 1-IN(9P) or REMOTE 1-OUT(9P) connector. The button lights when pressed.

**2(50P):** This unit is controlled by the device connected to the REMOTE 2 PARALLEL I/O(50P) connector. The button lights when pressed.

**RS-232C indicator:** This indicator lights when this unit is controlled through the RS-232C connector.

#### 3 EJECT button

To eject the cassette, press this button. While the cassette is being ejected, this button lights. When using the lower control panel as remote control panel, press the DELETE button and STOP button at the same time to eject the cassette.

#### Note

Ejecting with the EJECT button is a local operation. It is not possible to eject a cassette in another unit by remote control.

#### 4 Format indicators

The indicator (BETACAM/SP, BETACAM SX, MPEG IMX, Digital BETACAM, or HDCAM) corresponding to the current recording or playback format lights. The BETACAM/SP lights when the format is Betacam or Betacam SP.

#### 5 PHONES jack and control

Connect stereo headphones with an impedance of 8 ohms, to monitor the sound during playback and editing.

The control knob adjusts the volume.

It is possible to set an internal board switch so that the output volume from the MONITOR OUTPUT L and R connectors is controlled simultaneously.

*For details, refer to the Installation Manual.*

## 2-1-2 Lower Control Panel

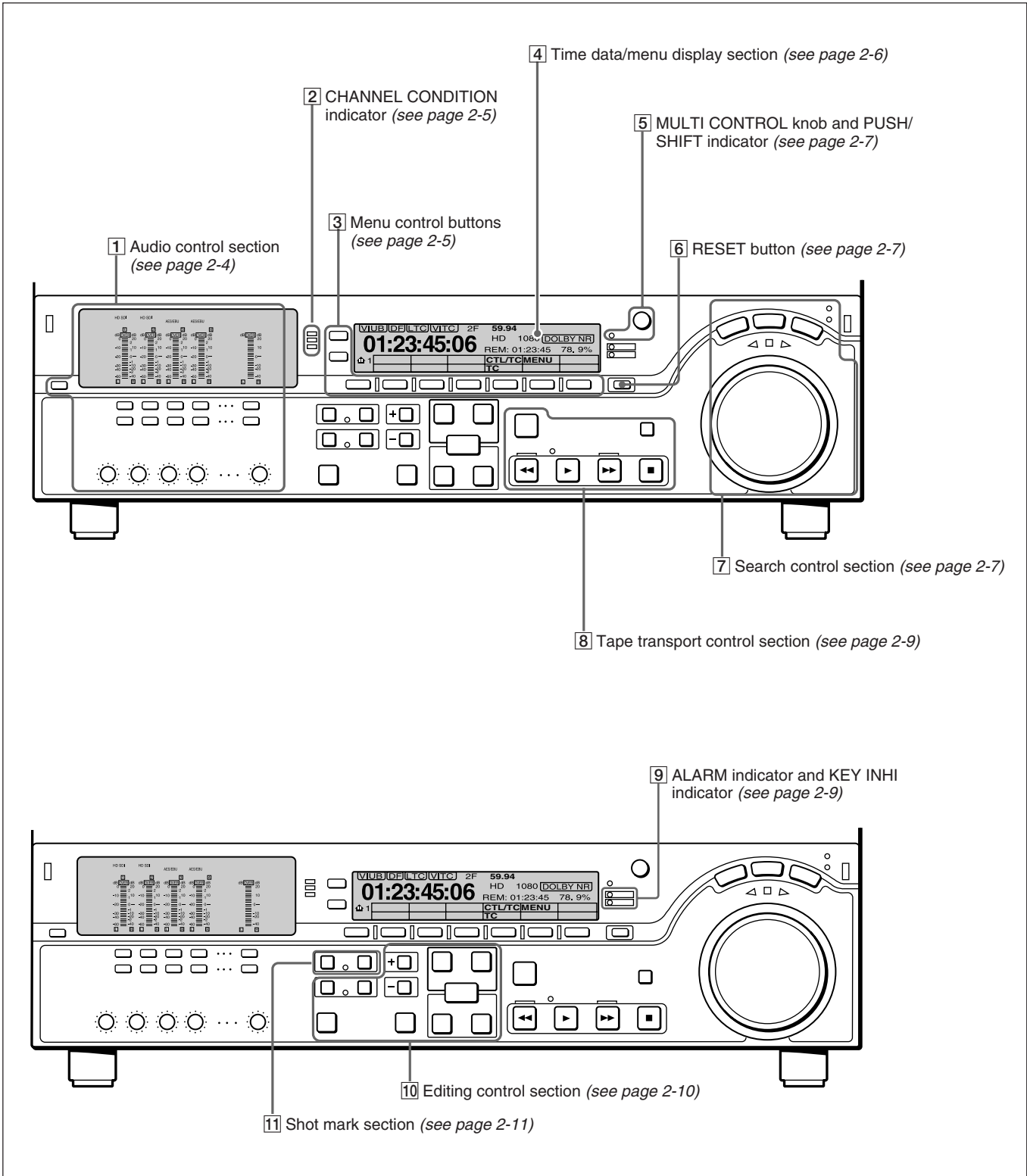

## 2-1 Control Panels

### 1 Audio control section

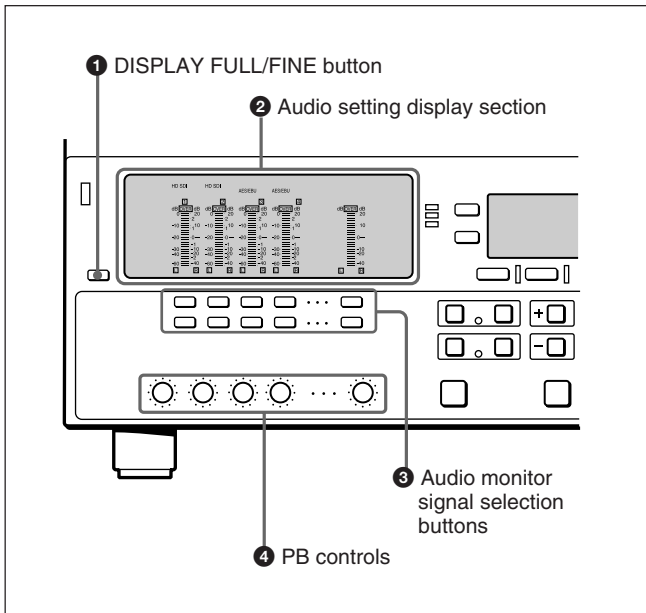

#### 1 DISPLAY FULL/FINE button

Pressing this button toggles the display mode of the level meters in the audio setting display section between FULL and FINE.

**FULL:** The display covers the range  $-60$  dB to  $0$  dB or  $-40$  dB to  $+20$  dB as selected using setup menu item 806. In this mode the segment of the display corresponding to the current audio level and all lower segments light.

**FINE:** The display is enlarged, with a step of  $0.25$  dB. A segment indicating the reference level lights. In this mode only the segment of the display corresponding to the current audio level lights. If the audio level exceeds the maximum display level, the top segment flashes, and if the audio level goes below the minimum display level, the bottom segment flashes.

### 2 Audio setting display section

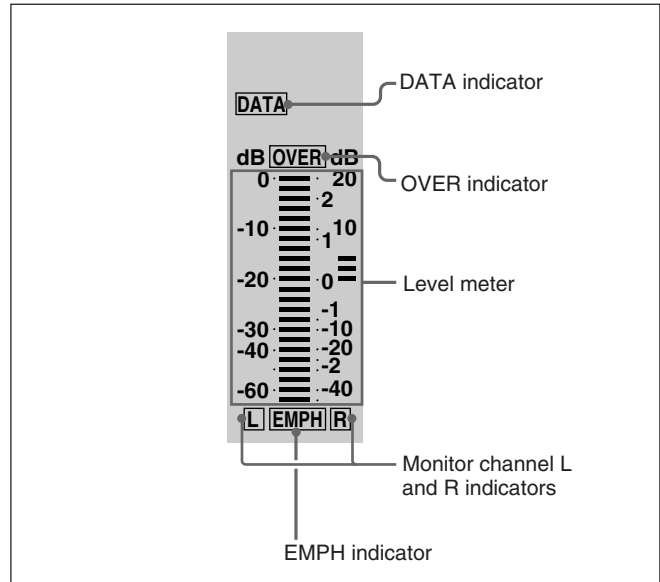

**DATA indicator:** Lights when the audio signals are recognized as data signals.

**OVER indicator:** While the unit is in playback mode, this lights when the level of the audio signal on the corresponding channel exceeds the maximum level that can be indicated on the level meter.

**Level meter:** Displays the audio signal level when the unit is in playback mode. You can use the setup menu to switch the display mode between PEAK.0 ( $0$  dB is maximum level) and REF.0 ( $0$  dB is the reference level). You can also use the DISPLAY FULL/FINE button 1 to enlarge the display only near the reference level.

**Monitor channel L and R indicators:** Indicate whether or not the signals of the track are output to the MONITOR OUTPUT L/R connectors and PHONES jack. 'L' lights to indicate output to the left monitor channel, and 'R' lights to indicate output to the right monitor channel.

**EMPH (emphasis) indicator:** While the unit is in playback mode, this lights when the emphasis setting is on for the audio signal on the corresponding track.

### 3 Audio monitor signal selection buttons (CH1 to CH4, and CUE)

The buttons in the upper and lower rows select tracks to be output to the MONITOR OUTPUT L and R connectors on the connector panel or the PHONES jack on the upper control panel. The buttons in the upper row (L row) select tracks for output to the MONITOR OUTPUT L connector, and the buttons on the lower row (R row) select tracks for output to the MONITOR OUTPUT R connector. You can obtain the mixed output of multiple tracks by simultaneously pressing multiple buttons in the upper or lower rows. For example, simultaneously press the CH1, CH2, and CH3 buttons in the upper row to mix the signals of audio tracks 1, 2, and 3 for output to the MONITOR OUTPUT L connector.

To monitor CH5 to CH8 in MPEG IMX playback, press the CUE button to switch between CH1 to CH4 and CH5 to CH8, and then select the desired channels.

### 4 PB (playback) controls

These adjust individually the playback levels on channels 1 to 4, and cue audio.

During playback, press to protrude the control knobs and adjust the level while monitoring the audio level indication on the level meters in the audio setting display section.

When the control knobs are pushed in, the playback levels return to the preset levels, and cannot be adjusted.

## 2 CHANNEL CONDITION indicator

A three-color indicator shows the state of the playback signal.

**Green:** The state of the playback signal is good.

**Yellow:** The playback signal is somewhat deteriorated, but playback is possible.

**Red:** The playback signal is deteriorated.

When this indicator remains on, head cleaning or an internal inspection is necessary.

## 3 Menu control buttons

These buttons are used for function menu (*see the following section "Overview of the function menu"*) and setup menu (*see Chapter 9*) operations. The page buttons (▼, ▲, and HOME) select menu pages, and the function buttons (F1 to F6) make function settings.

▼: Selects the next page in the order HOME → 1 → 2 → 3 → 4 → HOME.

▲: Selects the next page in the order HOME → 4 → 3 → 2 → 1 → HOME.

**HOME:** Selects the function menu HOME page.

**F1 to F6:** Make settings for the items displayed in the upper line of the menu display (the menu item display line). Pressing one of these buttons changes the setting for the corresponding item and displays the setting in the lower line of the menu display.

If there is no setting displayed in the lower line of the menu display, even though a menu item is displayed in the upper line, pressing the corresponding function button moves to a lower menu level.

### Overview of the function menu

The function menu provides convenient access to frequently used function settings, such as input video signal selection and time code settings.

*For details on the function menu, see Chapter 8.*

## 2-1 Control Panels

### 4 Time data/menu display section

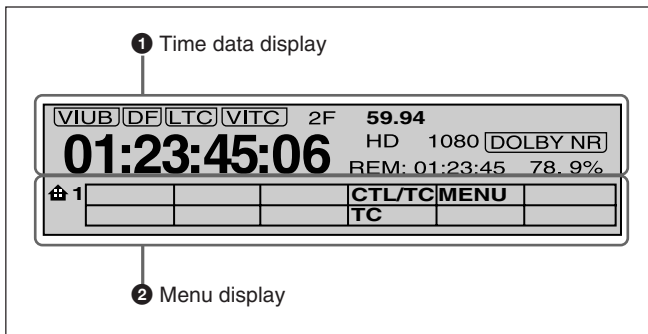

#### 1 Time data display

This displays indicators relating to time data and other indicators.

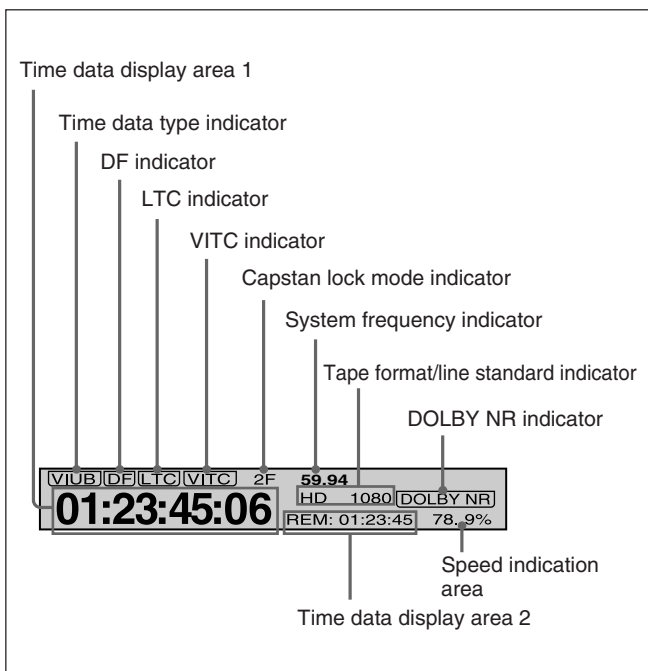

#### Time data display area 1

Normally this displays a CTL count, time code value, or user bit value according to the setting in function menu HOME page for F4 (CTL/TC).

#### Time data type indicator

This indicates the type of data displayed in the time data display area 1.

**LTC (longitudinal time code):** Time code recorded on a longitudinal track on the tape

**LUB:** LTC user bit values

**VITC (vertical interval time code):** Time code recorded in the vertical blanking interval

**VIUB:** VITC user bit value

#### DF (drop-frame) indicator (for 59.94i, 29.97PsF mode only)

This lights when values of drop-frame mode time code are displayed.

#### LTC indicator

Regardless of the display in the time data display area 1, this indicator lights when LTC values are being read.

#### VITC indicator

Regardless of the display in time data display area 1, this indicator lights when VITC values are being read.

#### Capstan lock mode indicator

This indicates the capstan lock mode (2F or 4F) set in function menu page 4 or in setup menu item 106.

#### System frequency indicator

This indicator shows the current system frequency.

#### Tape format/line standard indicator

This shows information about the tape format and the line standard conversion status.

Following are some examples and their meanings.

**IMX 1080:** Signals recorded in MPEG IMX format are output after conversion to 1080 line standard format signals.

**DB 1035:** Signals recorded in Digital Betacam format are output after conversion to 1035 line standard format signals.

**1035→1080:** HDCAM signals recorded in 1035 line standard format are output after conversion to 1080 line standard signals.

**HD 1080:** HDCAM signals recorded in 1080 line standard format are output with no change.

**DOLBY NR indicator**

This lights when the Dolby noise-reduction<sup>1)</sup> circuit is functioning.

**Speed indication area**

This indicates the speed of a DMC playback. During a DMC playback, “DMC SPD” is displayed in time data display area 2. However, CONFI playback is not possible during editing.

**Time data display area 2**

Displays data types and time data such as the time code of edit points and the total time of that tape.

The following data types are shown.

**TOTL:** Total time of the tape.

**REM:** Remaining time on the tape.

Depending on the setting of F5 (T INFO) on function menu page 3, either TOTL (TOTAL) or REM (REMAIN) is displayed.

The values displayed are approximate values calculated on the basis of the detected tape diameter. They are not precise to units of seconds.

The following appear when the top or end of the tape is reached.

**BOT:** Returned to top of tape.

**EOT:** Reached end of tape.

**IN:** video IN point

**OUT:** video OUT point

**AIN:** audio IN point

**AOUT:** audio OUT point

**DUR:** duration value

**TCG (time code generator):** time code generated by the internal time code generator

**2 Menu display**

This displays the function menu and setup menu.

For details on the function menu, see Chapter 8 and for details on the setup menu, see Chapter 9.

**5 MULTI CONTROL knob and PUSH/SHIFT indicator**

In function menu operations, rotate the MULTI CONTROL knob to change settings that flash in the menu display section. In setup menu operations, rotate this knob to select menu items.

The PUSH/SHIFT indicator lights when you press this knob in. In this state, the value of the setting changes by a greater amount when you rotate the knob.

**6 RESET button**

To reset a CTL, time code (TC) or user bit (UB) value displayed in time data display area 1, hold this button down.

Resetting the CTL value erases all edit points.

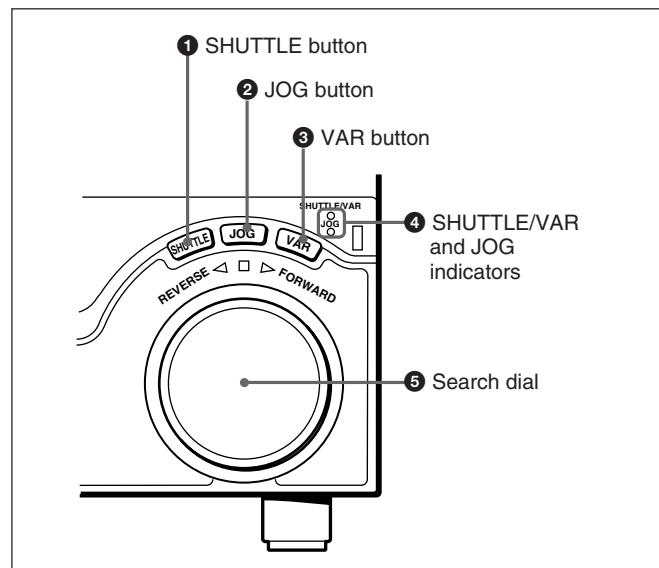
**7 Search control section****1 SHUTTLE button**

To use the search dial for playback in shuttle mode, press this button, turning it on.

For details of playback in shuttle mode, see the description of the search dial 5.

1) Dolby noise reduction: Dolby noise reduction manufactured under license from Dolby Laboratories Licensing Corporation. “DOLBY” and the double-D symbol  are trademarks of Dolby Laboratories Licensing Corporation.



## 2-1 Control Panels

### 2 JOG button

To use the search dial for playback in jog mode, press this button, turning it on.

For details of playback in jog mode, see the description of the search dial 5.

### 3 VAR (variable) button

To use the search dial for playback in variable speed mode, press this button, turning it on.

For details of playback in variable speed mode, see the description of the search dial 5.

### 4 SHUTTLE/VAR and JOG indicators

Either of the indicators is lit to show the current search mode or the mode used last.

**When the SHUTTLE/VAR indicator is lit:** Shuttle or variable speed mode

**When the JOG indicator is lit:** Jog mode

When the unit is turned on, the SHUTTLE/VAR indicator lights.

### 5 Search dial

Turn this to carry out playback in the modes shown in the following table. Turning the dial clockwise lights the ▷ indicator and plays back in the forward direction. Turning the dial counterclockwise lights the ◁ indicator and plays back in the reverse direction. When the tape is stopped or the unit is turned on, the □ indicator lights. Pressing the dial toggles between shuttle and jog modes or between variable speed and jog modes.

Depending on the tape format, noiseless playback is possible in the following ranges.

**HDCAM:** -1 to +2 times normal speed

**Digital Betacam:** -1 to +3 times normal speed

**MPEG IMX:** -1 to +3 times normal speed

**Betacam SX:** -1 to +2 times normal speed

**Betacam/Betacam SP:** -1 to +3 times normal speed

Playback modes using the search dial

Playback mode	Operations and functions
Shuttle	<p>Press the SHUTTLE button or the search dial so that the SHUTTLE button lights, then turn the search dial. Playback is carried out at a speed determined by the position of the search dial. Playback speed ranges are as follows.</p> <ul style="list-style-type: none"> <li>• HDCAM tape: ±50 times normal speed (59.94i, 29.97PsF mode), ±58 times normal speed (50i, 25PsF mode), ±60 times normal speed (24PsF, 23.98PsF mode)</li> <li>• Digital Betacam tape: ±50 times normal speed</li> <li>• MPEG IMX tape: ±60 times normal speed</li> <li>• Betacam SX tape: ±60 times normal speed</li> <li>• Analog Betacam tape: ±35 times normal speed (525/59.94 mode), ±42 times normal speed (625/50 mode)</li> </ul> <p>The search dial has detents at the still position and at ±5 times normal speed.</p> <p>The maximum shuttle mode playback speed can be changed by changing the setting of setup menu item 102 (see page 9-10).</p>
Jog	<p>Press the JOG button or the search dial so that the JOG button lights, then turn the search dial. Playback is carried out at a speed determined by the speed of rotation of the search dial. The playback speed range is ±1 time normal speed.</p> <p>The search dial has no detents.</p>
Variable speed	<p>Press the VAR button, turning it on, then turn the search dial. You can control the playback speed finely (a maximum of 51 steps) in the range in which noiseless playback is possible.</p> <ul style="list-style-type: none"> <li>• HDCAM, Betacam SX: Maximum 51 steps</li> <li>• Digital Betacam, MPEG IMX, analog Betacam: Maximum 54 steps</li> </ul> <p>The search dial has detents at the still position and at the normal speed position.</p>
Capstan override	<p>For details on operation, see page 4-4.</p>

Setting setup menu item 101 (see page 9-10) to KEY enables you to use only the SHUTTLE, JOG, and VAR buttons to select shuttle/jog/variable speed modes.



## 8 Tape transport control section

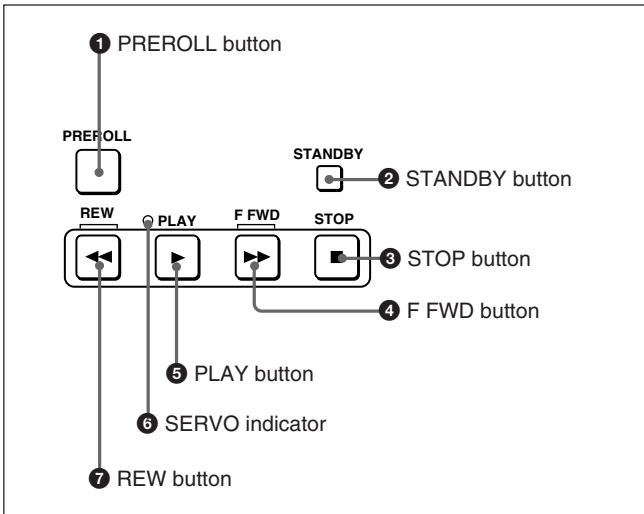

### 1 PREROLL button

Press this button to cue up to the preroll point (before the IN point by the time set as the preroll time) on the tape. You can change or select the preroll time and the state of the unit at the end of preroll (“stop mode”<sup>1)</sup> or still playback mode) using setup menu item 001 or 401.

### Cuing up to DMC playback control points

Hold down the STUNT IN, STUNT OUT, PLAY IN, or PLAY OUT button while pressing this button to cue up to the corresponding DMC playback control point.

### 2 STANDBY button

When this button is off with a cassette inserted in the unit, to put the unit in standby mode, press the button, turning it on.

In standby mode, the drum is rotating and the tape is in contact with the drum. As a result, playback can start immediately.

To end standby mode, press the STANDBY button, turning it off.

If 8 minutes (value can be varied using setup menu item 501) elapse in standby mode, the unit automatically switches out of standby mode to protect the tape.

### 3 STOP button

To stop playback, press this button, turning it on.

### Fault display function

The STOP button flashes in the following cases:

- When setup menu item 105 is set to ON, there is no external reference signal input.
- The input external reference signal is different from the signal specified by setup menu item 337.

### 4 F FWD (fast forward) button

To fast forward the tape, press this button, turning it on.

### 5 PLAY button

To start playback, press this button, turning it on.

### To operate in capstan override mode

Hold down this button, and turn the search dial.

*For details of capstan override mode, see page 4-4.*

### 6 SERVO indicator

Lights when the drum servo and capstan servo are locked.

### 7 REW (rewind) button

To rewind the tape, press this button, turning it on.

## 9 ALARM indicator and KEY INHI indicator

### ALARM indicator

This lights when a hardware error is detected on the unit, and goes off when the error is resolved.

When this indicator is lit, an error message appears in the time data/menu display section. If you are using the HDSDI OUTPUT 3 (SUPER), SDI OUTPUT 3 (SUPER) or COMPOSITE VIDEO OUTPUT 3 (SUPER) connector, then when the setting of F4 (CHARA) in function menu page 4 is ON, the error message also appears on the monitor screen.

*For details on error messages, refer to Section 1-24 in the Maintenance Manual Volume 1.*

### KEY INHI (inhibit) indicator

This indicator lights when the KEY INHI switch on the switch panel (*see page 2-11*) is set to ON.

1) Stop mode: The state in which the device currently the subject of operation is stopped, and the STOP button is lit.

## 2-1 Control Panels

### 10 Editing control section

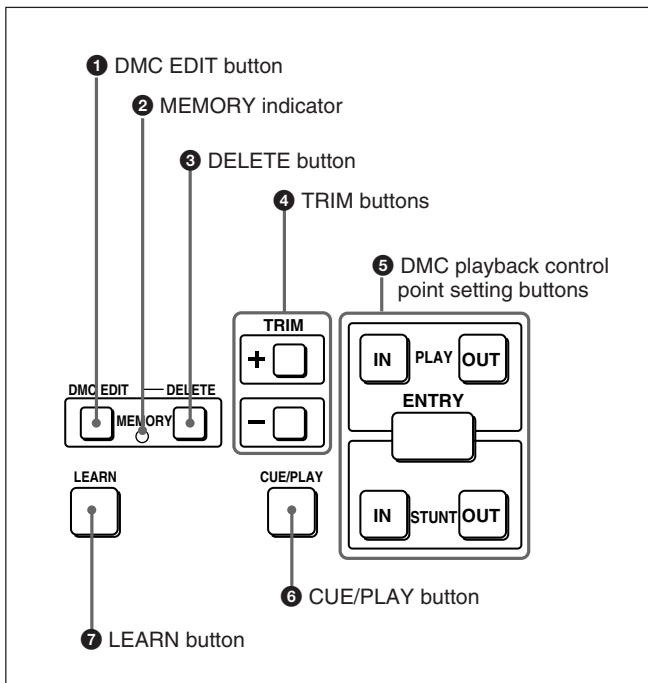

#### 1 DMC EDIT button

Use this button to memorize the playback speed varied between  $-1$  and  $+2$  times normal speed, and carry out automatic playback or automatic editing using the memorized playback speed.

#### 2 MEMORY indicator

When memorizing the playback speed using the DMC EDIT button, this indicator flashes as the playback speed is captured to memory, and lights continuously once the speed is captured.

#### 3 DELETE button

This deletes an existing edit point. Hold down this button and press the STUNT IN, STUNT OUT, PLAY IN, or PLAY OUT button which is lit, indicating an existing edit point, to delete the corresponding edit point. The button either goes off or flashes. When the button flashes, it is necessary to set the deleted edit point again. To cancel the DMC mode, hold down the DMC EDIT button and press the DELETE button.

#### 4 TRIM buttons

Use these buttons to trim an edit point to single-frame precision.

Hold down the STUNT IN, STUNT OUT, PLAY IN, or PLAY OUT button, and press one of these buttons. The '+' button advances the corresponding edit point by one frame, and the '-' button sets it back by one frame.

Pressing one of these buttons while holding down the PLAY button adjusts the tape speed by  $+8\%$  or  $-8\%$  correspondingly. (Capstan override function)

#### 5 DMC playback control point setting buttons PLAY IN button and PLAY OUT button

To set an on-air start or end point, hold down the PLAY IN button or PLAY OUT button, and press the ENTRY button.

After you have made the setting, pressing the PLAY IN button or PLAY OUT button displays the on-air start or end point set in time data display area 2.

#### STUNT IN button and STUNT OUT button

To set a speed variation start or end point, hold down the STUNT IN button or STUNT OUT button, and press the ENTRY button.

After you have made the setting, pressing the STUNT IN button or STUNT OUT button displays the speed variation start or end point set in time data display area 2.

#### ENTRY button

Use this for setting DMC playback control points and so on.

- **To set a speed variation start or end point:** Hold down the STUNT IN button or STUNT OUT button, and press this button.
- **To set an on-air start or end point:** Hold down the PLAY IN button or PLAY OUT button, and press this button.

#### 6 CUE/PLAY (cue up/playback) button

After setting an on-air start point (PLAY IN point) or an on-air end point (PLAY OUT point), pressing this button cues up the tape to the on-air start point. The button then starts flashing to indicate that the unit is ready for DMC playback operation. To start DMC playback, press the button again.

**7 LEARN button**

After setting a speed variation start point (STUNT IN point) and a speed variation end point (STUNT OUT point), pressing this button makes the tape start running. You can then use the search dial to vary the tape speed, which is automatically stored in memory. After thus storing the tape speed variation in memory, pressing this button starts an automatic playback between the speed variation start and end points at the stored speed.

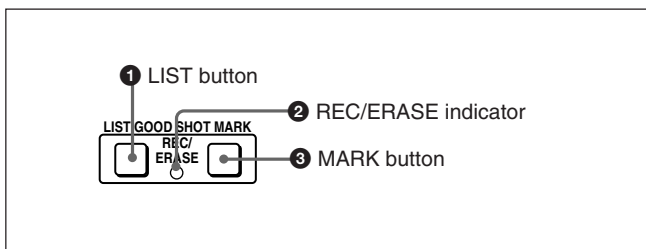
**11 Shot mark section****1 LIST button**

Use this button to read in and list shot marks.

**2 REC/ERASE indicator**

This lights in the state in which writing, amending, and deleting of shot marks is enabled and flashes while a shot mark is actually being written, amended or deleted.

**3 MARK button**

Hold this button down for 2 seconds or more, to enable writing, amending, and deleting of shot marks.

**2-1-3 Switch Panel**

To access the switch panel, open the lower control panel.

On how to open the lower control panel, see the figure on page 2-1.

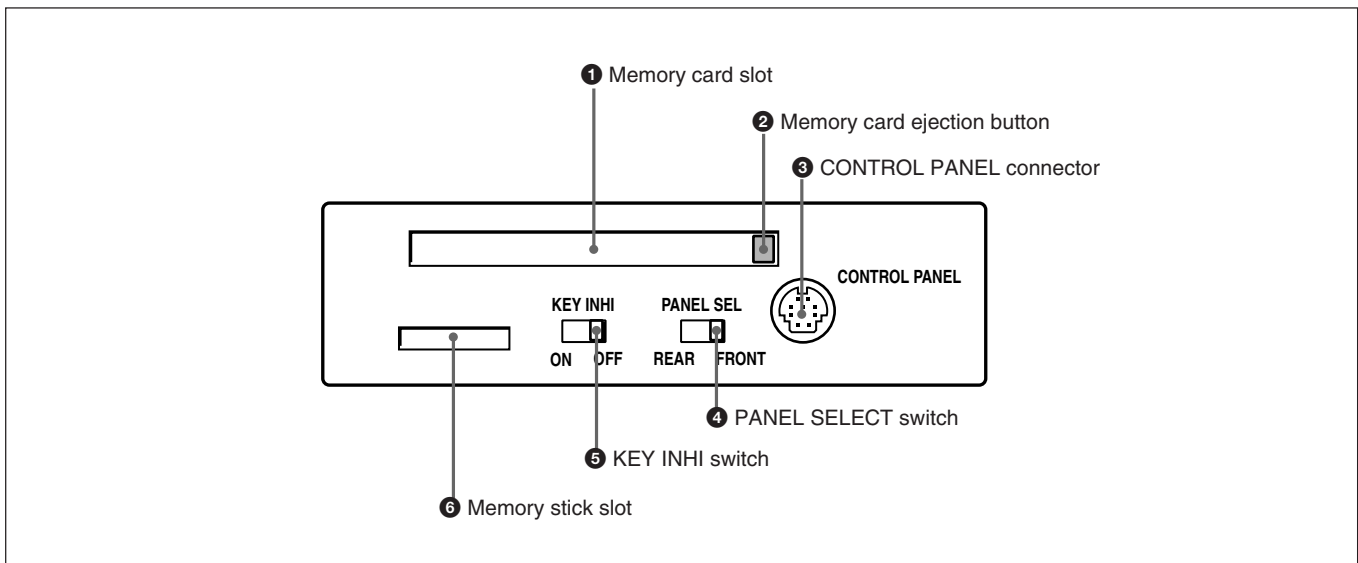

## 2-1 Control Panels

---

### ❶ Memory card slot

Insert a memory card to update this unit's firmware. You can save or load setup menu settings onto the memory card.

*For details on firmware update and setup menu reading/storing, refer to the Maintenance Manual Volume 1.*

### ❷ Memory card ejection button

Press to eject a memory card from the memory card slot.

### ❸ CONTROL PANEL connector (10-pin, round type)

Plug in the lower control panel connection cable.

### ❹ PANEL SELECT switch

In addition to the lower control panel, you can connect a similar control panel to this unit. When two control panels are connected to the unit, the PANEL SELECT switch is used to specify which panel be enabled to control the unit.

**FRONT:** Enables the control panel connected to the CONTROL PANEL connector on the switch panel.

**REAR:** Enables the control panel connected to the CONTROL PANEL connector on the connector panel. When setup menu item 117 is set to PARA, this switch position also enables the control panel connected to the CONTROL PANEL connector on the switch panel.

### ❺ KEY INHI switch

Moving this switch to the ON position disables the controls on the upper and lower control panels. You can specify which buttons and knobs are disabled in setup menu item 118.

### ❻ Memory stick slot

Use this to update the firmware. You can also save or load setup menu settings onto the memory stick.

#### Note

After inserting a memory stick or memory card, allow at least five seconds to elapse before removing it.

*For details on firmware update and save or load setup menu settings, refer to the Maintenance Manual Volume 1.*

# 2-2 Connector Panel

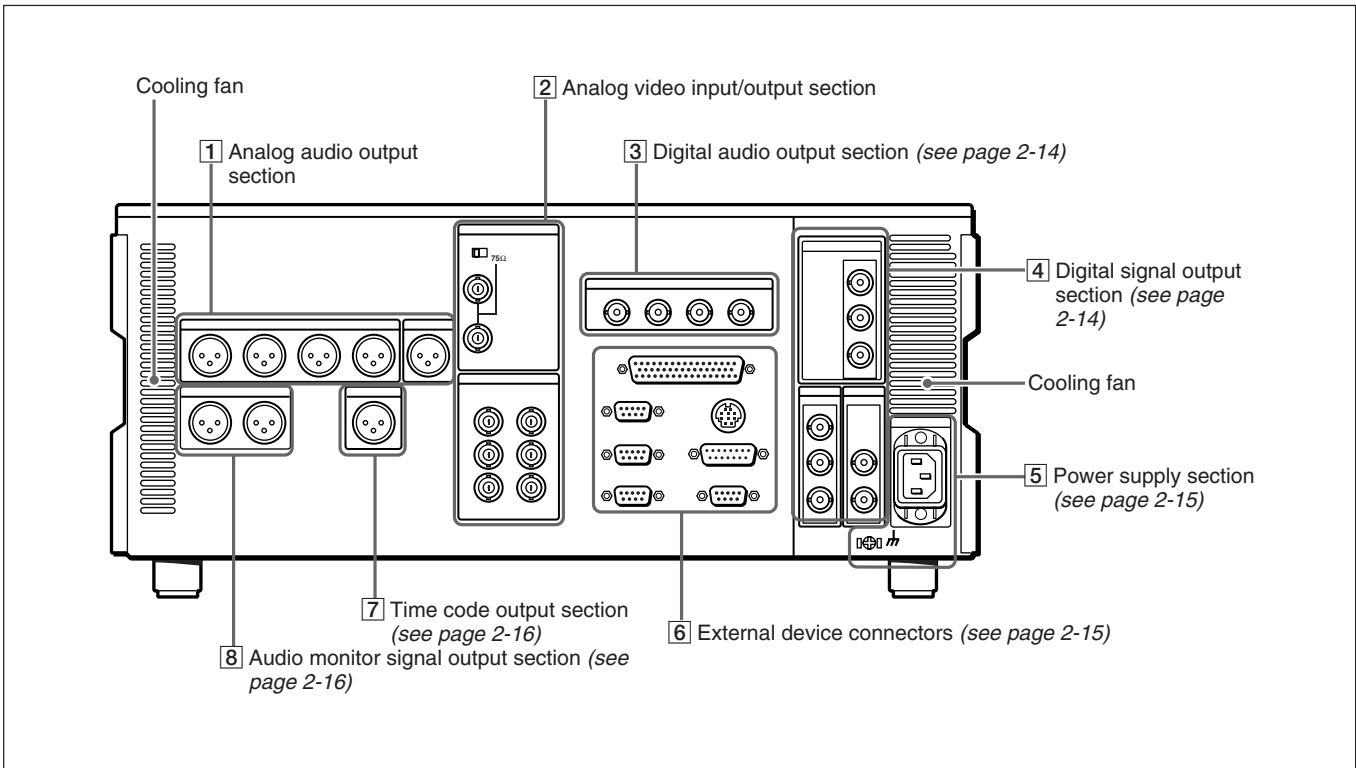

## 1 Analog audio output section

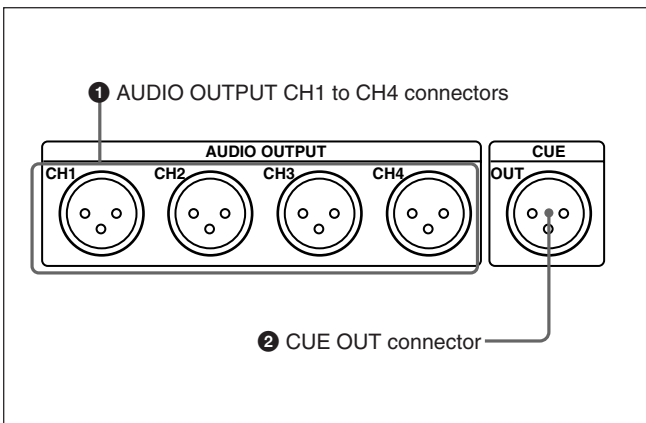

### 1 AUDIO OUTPUT CH1 to CH4 (channels 1 to 4) connectors (XLR 3-pin, male)

These connectors output analog audio signals for channels 1 to 4.

### 2 CUE OUT (cue audio output) connector (XLR 3-pin, male)

This connector outputs the analog cue audio signals.

## 2 Analog video input/output section

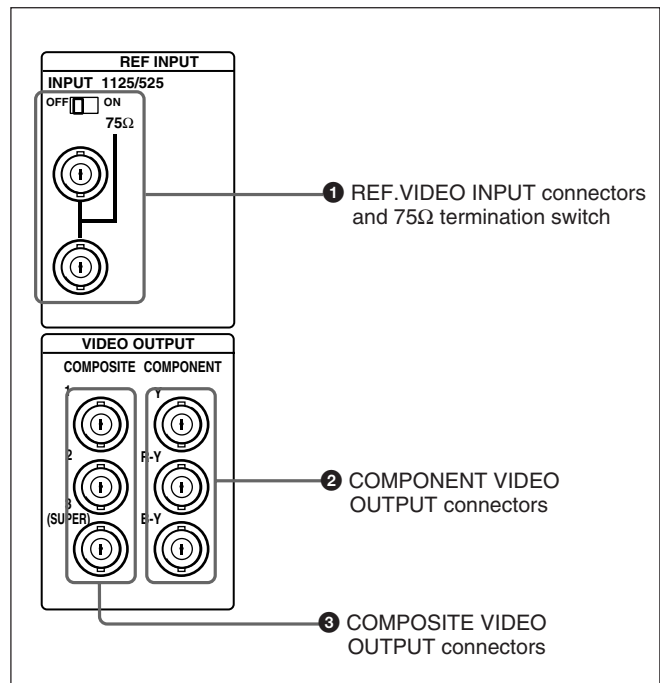

## 2-2 Connector Panel

### 1 REF. (reference) VIDEO INPUT connectors (BNC type) and 75Ω termination switch

Input a reference video signal. Input a three-valued (positive and negative) sync signal, a video signal with chroma burst (VBS) or a monochrome video signal (VS). When using the loop-through connection set the switch to the OFF position, and otherwise to the ON position.

### 2 COMPONENT VIDEO OUTPUT connectors (BNC type)

These connectors output analog component video signals (Y/R-Y/B-Y).

### 3 COMPOSITE VIDEO OUTPUT connectors (BNC type)

These connectors output analog composite video signals.

When the setting of F4 (CHARA) in function menu page 4 is ON, connector 3 (SUPER) outputs a signal with superimposed time code, menu settings, alarm messages, and other text information.

### 3 Digital audio output section

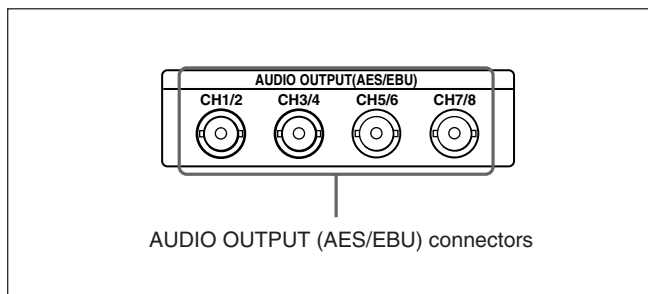

### AUDIO OUTPUT (AES/EBU) connectors (BNC type)

Output a maximum of 4 sets (8 channels: CH1/2, CH3/4, CH5/6, CH7/8) of AES/EBU format digital audio signals.

### 4 Digital signal output section

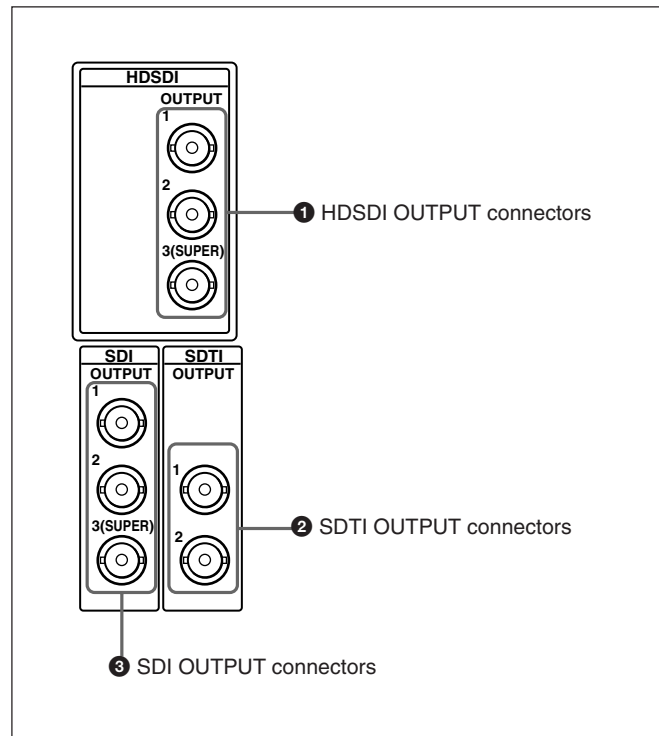

### 1 HDSDI (HD Serial Digital Interface) OUTPUT connectors (BNC type)

These connectors output HD format video/audio signals. When the setting of F4 (CHARA) in function menu page 4 is ON, connector 3 (SUPER) outputs a signal with superimposed time code, menu settings, alarm messages, and other text information.

### 2 SDTI (Serial Data Transport Interface) OUTPUT connectors (BNC type)

Output SDTI format video and audio signals.

### 3 SDI (Serial Digital Interface) OUTPUT connectors (BNC type)

These connectors output D1 format video/audio signals.

When the setting of F4 (CHARA) in function menu page 4 is ON, connector 3 (SUPER) outputs a signal with superimposed time code, menu settings, alarm messages, and other text information.

## 5 Power supply section

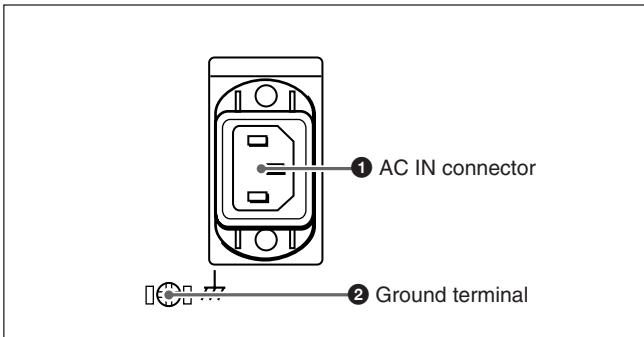

### 1 AC IN connector

Use the optional power cord to connect this to an AC outlet.

### 2 Ground terminal

Connect this to ground.

## 6 External device connectors

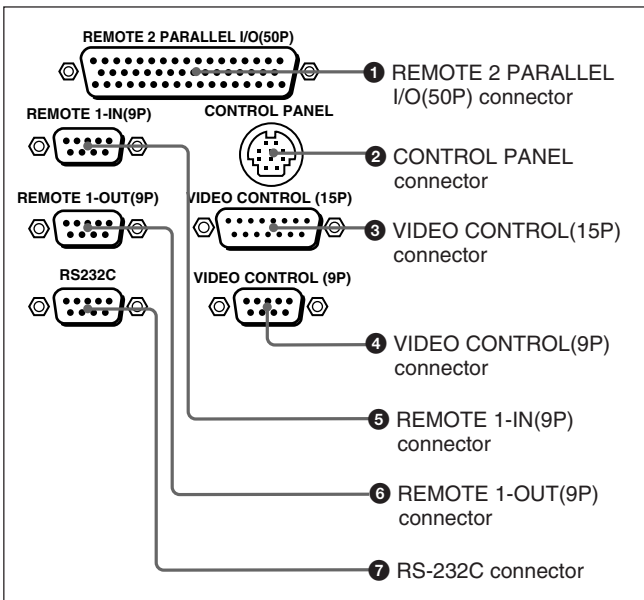

### 1 REMOTE 2 PARALLEL I/O(50P) connector (D-sub 50-pin)

Connect remote control signals from an external device.

For details, refer to the Installation Manual.

### 2 CONTROL PANEL connector (round type, 10-pin)

In addition to the lower control panel, a similar control panel can be connected to this unit. To connect such a second control panel, use this connector. When two control panels are connected, use the PANEL SELECT switch on the switch panel (see page 2-11) to specify which control panel will control this unit.

### 3 VIDEO CONTROL(15P) connector (D-sub 15-pin)

For remote control of the internal digital video processor, connect an optional BVR-50/50P Video Remote Control Unit.

Always power off this unit before connecting the remote control unit.

### 4 VIDEO CONTROL(9P) connector (D-sub 9-pin)

For remote control of the internal digital video processor, connect an optional HKDV-900 Video Remote Control Unit.

Always power off this unit before connecting the remote control unit.

### 5 REMOTE 1-IN(9P) connector (D-sub 9-pin)

When using this unit together with another HDCAM VTR, and a BVE-series BVE-700/900/910/2000/9000/9000P/9100/9100P or other editor, connect the optional 9-pin remote control cable from the other unit to this connector.

Depending on the setting of setup menu item 211, you can use this connector alone, or in a loop-through configuration with the REMOTE 1-OUT(9P) connector.

### 6 REMOTE 1-OUT(9P) connector (D-sub 9-pin)

This provides the loop-through output for remote control signals from the REMOTE 1-IN(9P) connector.

Depending on the setting of setup menu item 211, you can use this connector alone, or in a loop-through configuration with the REMOTE 1-IN(9P) connector.

### 7 RS-232C connector (D-sub 9-pin)

Use this for monitoring and diagnosis of the state of this unit from an external computer, using the ISR (Interactive Status Reporting) function.



## 2-2 Connector Panel

### 7 Time code output section

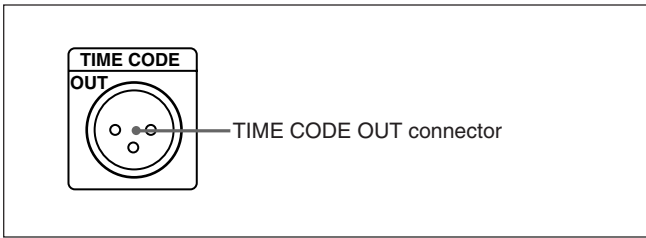

#### **TIME CODE OUT connector (XLR 3-pin, male)**

This outputs the playback time code.

By setting setup menu item 606, you can also output the time code from the internal time code generator locked to the playback time code.

### 8 Audio monitor signal output section

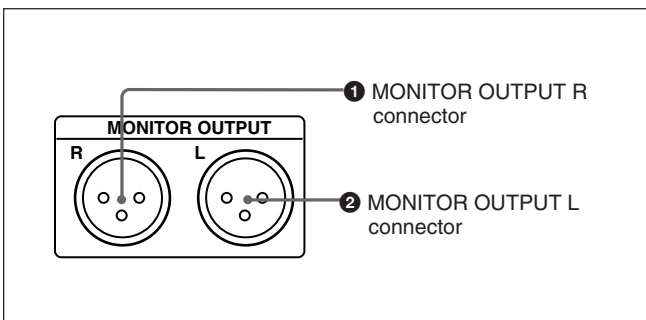

#### **1 MONITOR OUTPUT R connector (XLR 3-pin, male)**

This outputs the audio signals whose output destination was set to 'R' with the audio signal selection buttons in the audio control section. If multiple tracks have been set to 'R', the signals of those tracks are mixed for output.

#### **2 MONITOR OUTPUT L connector (XLR 3-pin, male)**

This outputs the audio signals whose output destination was set to 'L' with the audio signal selection buttons in the audio control section. If multiple tracks have been set to 'L', the signals of those tracks are mixed for output.



# 3-1 Connections to External Devices

## 3-1-1 Connections to Digital Devices

The following example shows the connections with an HDW-2000/M2000/M2000P unit as a recorder, with this unit used as a player.

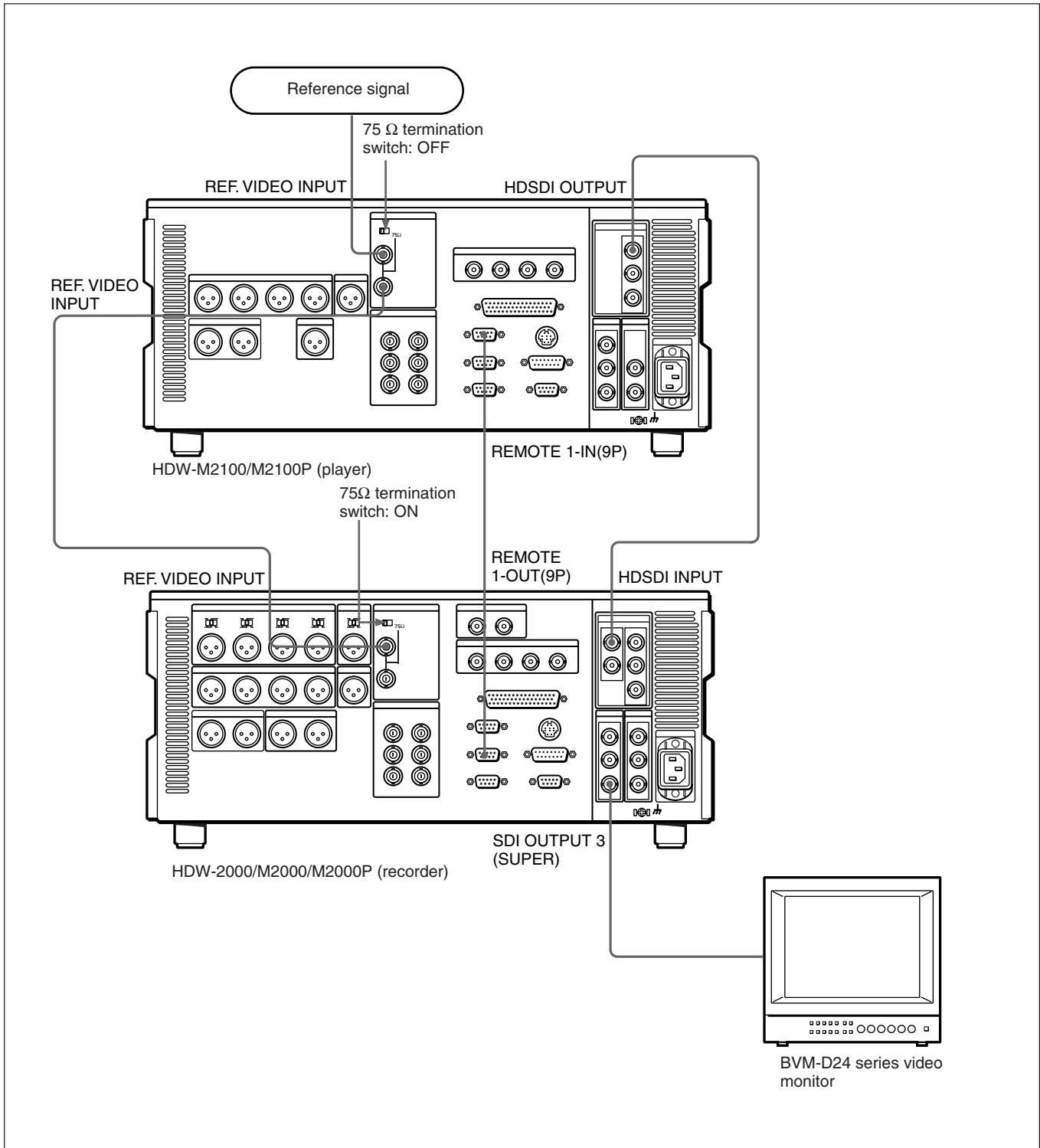

# 3-1 Connections to External Devices

## 3-1-2 Connecting Reference Signals

Connect reference signals as shown below.

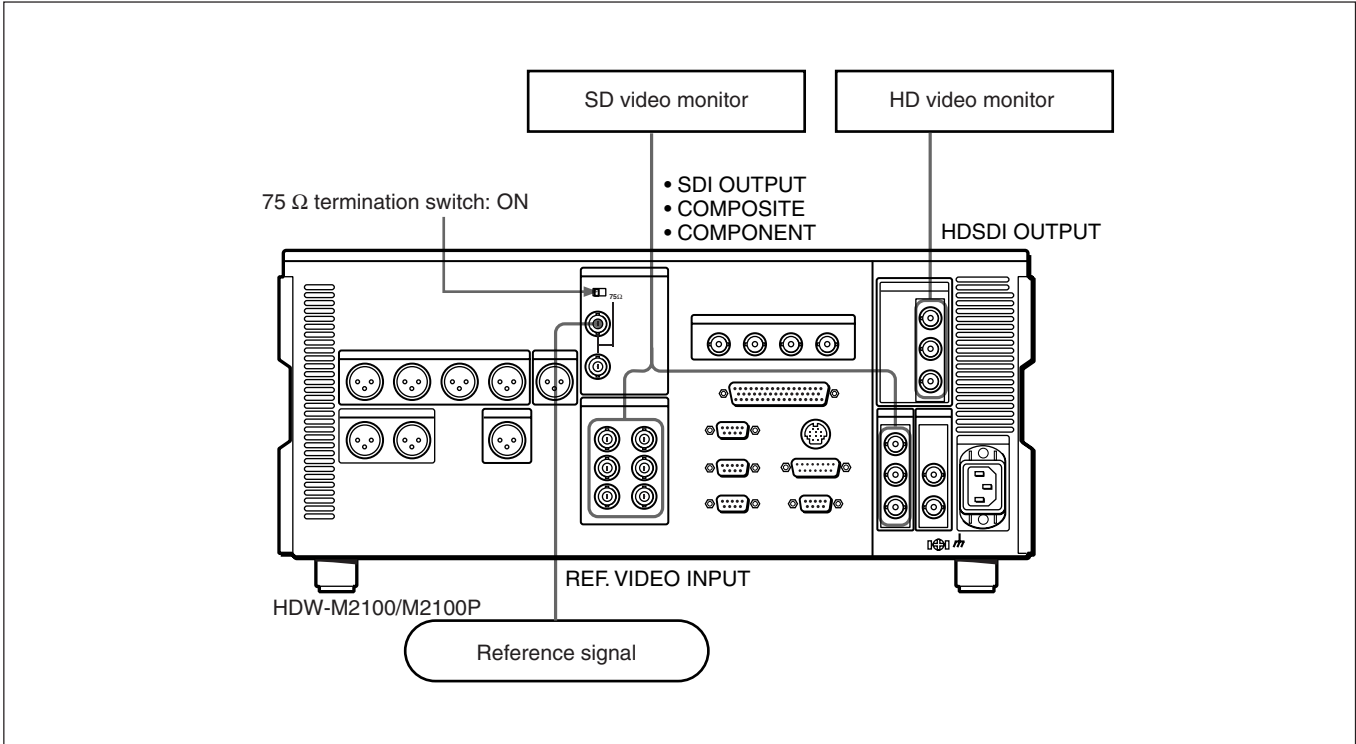

## 3-2 Setup

The principal setup operations before operating this unit can be carried out using setup menus.

The setup menus of this unit comprise a basic setup menu and an extended setup menu. The contents of these menus are as follows.

### **Basic setup menu:**

- Items relating to the hours meter
- Items relating to operation
- Items relating to menu banks

### **Extended setup menu:**

- Items relating to control panels
- Items relating to the remote control interface
- Items relating to editing operations
- Items relating to preroll
- Items relating to tape protection
- Items relating to the time code generator
- Items relating to video control
- Items relating to audio control
- Items relating to digital processing

*For detailed information about the items, except for the basic setup menu items relating to the hours meter, of these menus and how to use them, see Chapter 9 “Setup Menus”. For detailed information about menu operations relating to the hours meter, see Section 10-5-1 “Digital Hours Meter”(page 10-5).*

This unit allows menu settings to be saved in what are termed “menu banks.” Saved sets of menu settings can be recalled for use as required.

*For more information about the menu banks, see the section “Menu bank operations (menu items B01 to B13)” (page 9-5).*

# 3-3 Superimposed Character Information

When the function menu item CHARA is set to ON, the video signal output from the HDSDI OUTPUT 3 (SUPER) connector, SDI OUTPUT 3 (SUPER) connector, or COMPOSITE VIDEO OUTPUT 3 (SUPER) connector contains superimposed character information, including time code, menu settings, and alarm messages.

## Adjusting the character display

You can adjust the position, size and type of the superimposed characters using setup menu items 002, 003, 005, 009, and 011.

*For details, see Section 9-3 “Items in the Basic Setup Menu” (page 9-7).*

## Information displayed

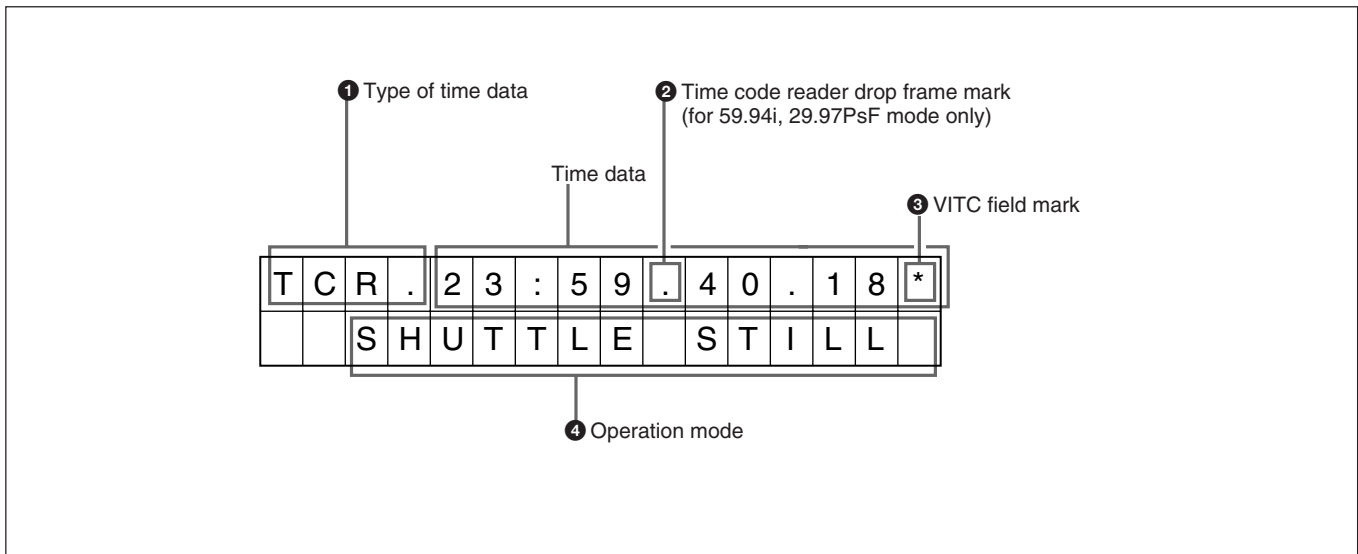

### Note

The display shown above corresponds to the factory default settings of the unit. Changing the setting of setup menu item 005 allows different time data to be displayed in the lower line of the display.

*For details, see Section 9-3 “Items in the Basic Setup Menu” (page 9-7).*

### 1 Type of time data

Display	Meaning
CTL	CTL counter data
TCR	LTC reader time code
UBR	LTC reader user's bits
TCR.	VITC reader time code
UBR.	VITC reader user's bits
IN	IN point
OUT	OUT point
AI	Audio IN point
AO	Audio OUT point
DUR	Duration between any two of the four edit points (IN, OUT, audio IN, audio OUT)

### Note

If the time data or user's bits cannot be read correctly, they will be displayed with an asterisk. For example, “T\*R”, “U\*R”, “T\*R.” or “U\*R.”.

## ② Time code reader drop frame mark (for 59.94i, 29.97PsF mode only)

“.”: Indicates drop frame mode

“:”: Indicates non-drop-frame mode

## ③ VITC field mark

“ ” (blank): Fields 1 and 3 (for 59.94i, 29.97PsF mode) or fields 1, 3, 5 and 7 (for 50i, 25PsF mode)

“ \* ”: Fields 2 and 4 (for 59.94i, 29.97PsF mode) or fields 2, 4, 6 and 8 (for 50i, 25PsF mode)

## ④ Operation mode

The field is divided into three blocks, A, B and C.

- Block A displays the operation mode.
- Block B displays the servo lock status or tape speed.
- Block C displays a ■ mark to indicate an edit section during automatic editing.

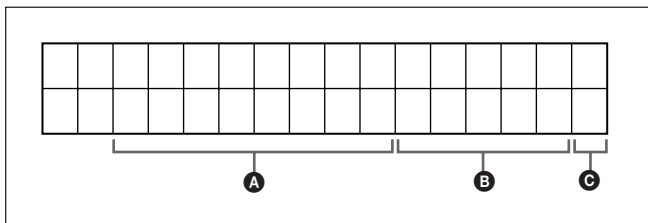

Display		Operation mode
Block A	Block B	
TAPE UNTHREAD		Cassette is not loaded.
STANDBY OFF		Standby off mode
T.RELEASE		Tape tension released
STOP		Stop mode
F.FWD		Fast forward mode
REW		Rewind mode
PREROLL		Preroll mode
PLAY		Playback mode (servo unlocked)
PLAY	LOCK	Playback mode (servo locked)
PLAY	Variation from normal speed (%)	Capstan override mode (see page 4-4)
JOG	STILL	A still picture in jog mode
JOG	FWD	Jog mode in forward direction
JOG	REV	Jog mode in reverse direction
SHUTTLE	(Speed)	Shuttle mode
VAR	(Speed)	Variable speed mode
DMC	(Speed) <sup>a)</sup>	DMC playback speed
D-PREV	(Speed) <sup>a)</sup>	DMC editing preview mode
D-EDIT	(Speed) <sup>a)</sup>	DMC editing mode
DMC-SPD	(Speed)	DMC initial speed setting
PLY-SPD	Variation from normal speed	Tape speed override mode (when "TSO" is selected in setup menu item 111)

a) Initial speed settings or stored speed settings

# 3-4 Cassettes

## 3-4-1 Cassette Types

This unit uses the following HDCAM cassettes for playback.

HDCAM cassettes

<b>Small cassettes</b>	BCT-6HD/12HD/22HD/32HD/40HD
<b>Large cassettes</b>	BCT-34HDL/64HDL/94HDL/124HDL

The unit can also play back the following cassettes.

- Digital Betacam cassettes
- MPEG IMX cassettes
- Betacam SX cassettes
- Betacam SP cassettes (metal tape)
- Betacam cassettes (oxide tape)

## 3-4-2 Inserting and Ejecting Cassettes

It is not possible to insert or eject a cassette unless the unit is powered on.

### Inserting a cassette

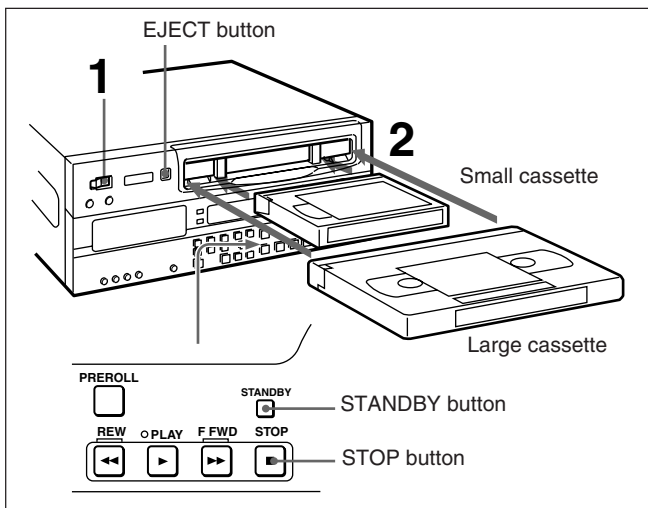

- 1 Turn the POWER switch on.

- 2 Check the following points, then insert the cassette in the orientation shown in the figure.
  - Check that message “ERR-10” is not shown in the time data/menu display section.
  - Check that there is no slack in the tape.

The cassette is drawn into the unit, and the STANDBY and STOP buttons light.

*If message “ERR-10” appears in the time data/menu display section, there is moisture condensation in the unit.*

### Removing slack from the tape

Press in one of the reels with a finger, and turn gently in the direction shown by the arrows until there is no slack in the tape.

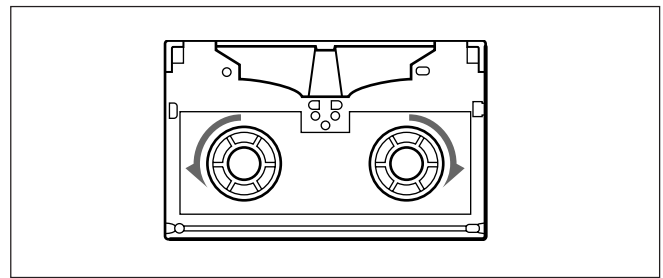

### Ejecting a cassette

Press the EJECT button.

#### Note

Ejecting is a local operation. It is not possible to eject a cassette in another unit by remote control.

*If the tape slacks inside the unit, pressing the EJECT button may not eject the cassette. For information about how to remove the cassette in such a case, refer to the Installation Manual.*

### 3-4-3 Preventing Accidental Recording of Shot Marks

To prevent shot marks from being accidentally recorded on a tape, press in the red record inhibit plug on the cassette.

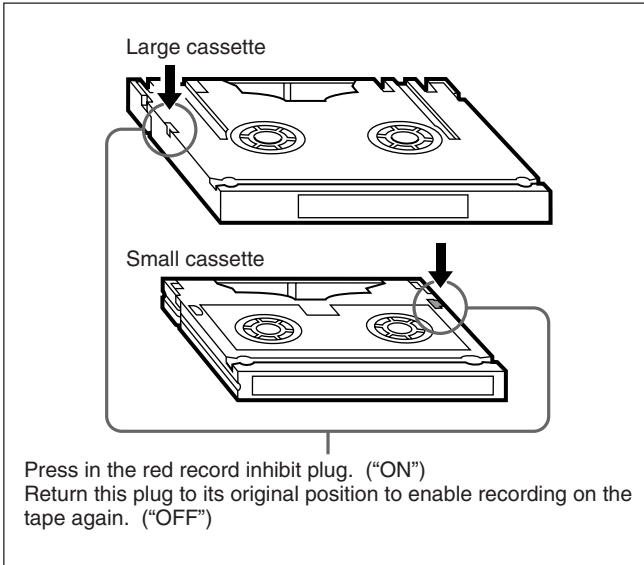

## 3-5 Using a Memory Stick

When a **Memory Stick** is inserted in the VTR, the file data can be stored on the **Memory Stick**, which enables you to share data among cameras.

### Note

Use a **Memory Stick** formatted with this VTR. It cannot be shared with other devices.

*For more details, refer to the Maintenance Manual.*

### Inserting a Memory Stick

Insert a **Memory Stick** with the label side up into the **Memory Stick** slot until it clicks.

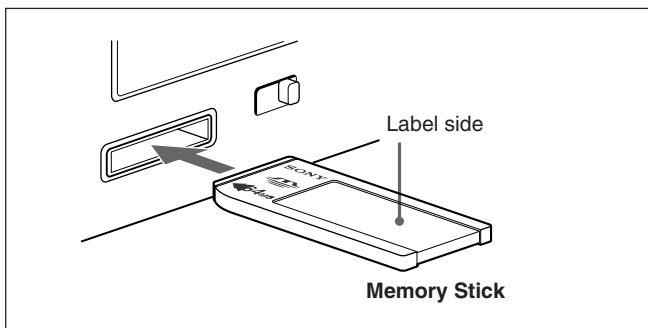

### Note

Never insert/remove a **Memory Stick** during access to data.

### To remove a Memory Stick

If you push the inserted **Memory Stick**, the **Memory Stick** will pop out a little. Then pull the **Memory Stick** out.

### 3-5-1 Notes on Memory Stick

#### On Memory Stick

**Memory Stick** is a new compact, portable and versatile IC recording medium with a data capacity that exceeds that of a floppy disk. **Memory Stick** is specially designed for exchanging and sharing digital data among **Memory Stick** compatible products. Because it is removable, **Memory Stick** can also be used for external data storage.

#### Types of Memory Stick

There are two types of **Memory Stick**: MagicGate **Memory Stick** that is equipped with the MagicGate copyright protection technology and general **Memory Stick**. Use the general type **Memory Stick** (8MB, 16MB, 32MB, 64MB, 128MB) with your camera.

#### On MagicGate

MagicGate is copyright-protection technology that uses encryption technology.

#### Before using a Memory Stick

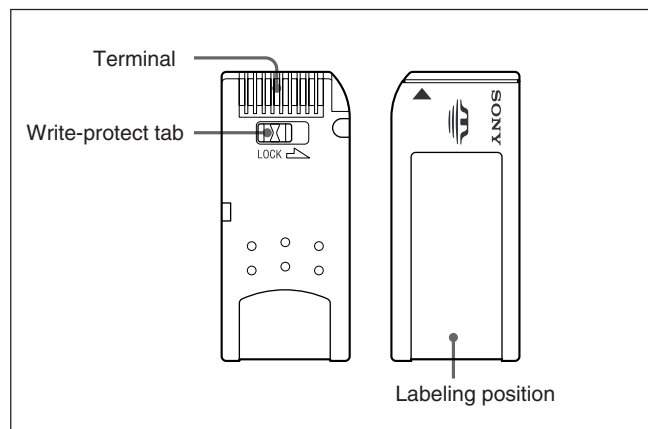

- You cannot record or erase data when the write-protect tab on the **Memory Stick** is set to LOCK.
- We recommend backing up important data.
- Image data may be damaged in the following cases:
  - If you remove the **Memory Stick**, or turn the power off during access to data
  - If you use a **Memory Stick** near static electricity or a magnetic field



**Notes**

- Prevent metallic objects or your finger from coming into contact with the terminal of the connecting section.
- Do not attach any material other than the supplied label to the label space.
- Attach the label at the prescribed labeling position. Make sure the label is attached at the labeling position properly.
- Do not bend, drop, or apply strong shock to a **Memory Stick**.
- Do not disassemble or modify a **Memory Stick**.
- Do not let the **Memory Stick** get wet.
- Do not use or keep a **Memory Stick** in locations that are:
  - Extremely hot such as in a car parked in the sun
  - Under direct sunlight
  - Very humid or subject to corrosive gases
- When you carry or store a **Memory Stick**, keep it in its case.

---

**During access to data**

While data are being read from or written to the **Memory Stick**, do not shake the camera or subject it to shock. Do not turn off the power of the camera or remove the **Memory Stick**. This may damage the data.

*For details, refer to the Maintenance Manual.*

**Memory Stick** and  are the trademarks of Sony Corporation.

MagicGate **Memory Stick** and  are the trademarks of Sony Corporation.

# 4-1 Playback

This section describes playback of video and audio.

## 4-1-1 Preparations for Playback

### Switch and menu settings

Before beginning playback, make necessary switch and menu settings.

*For details on each setting, see the pages indicated in parenthesis.*

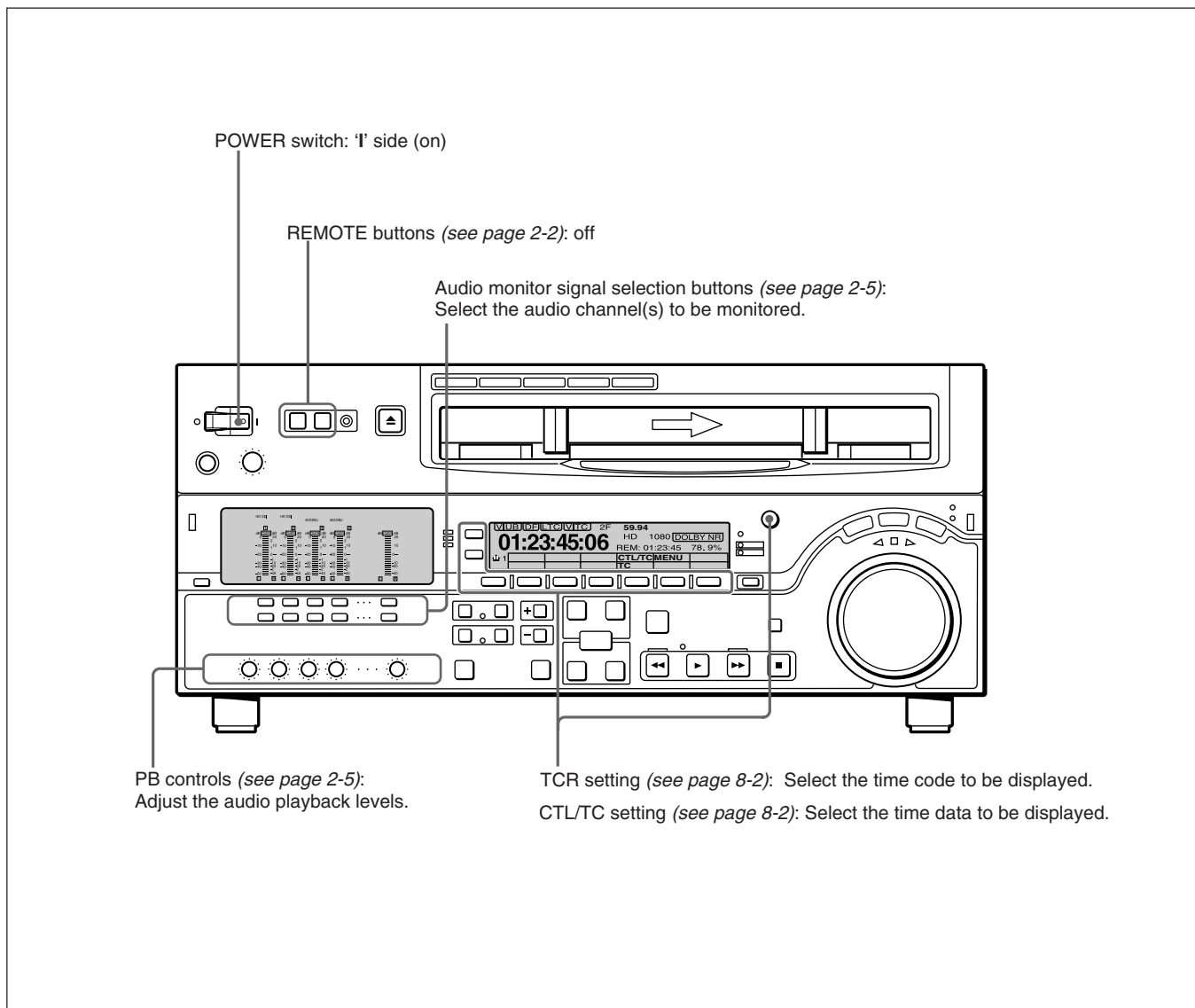

## 4-1 Playback

### Time data selection

#### Displayed time data

Use the CTL/TC setting in function menu HOME page to select one of CTL (control), time code, and user bit values. When you select time code, the data displayed is determined by the F6 (TCR) setting (LTC/AUTO/VITC) in function menu page 1 as follows.

TCR setting	Displayed data
LTC	LTC recorded on tape
AUTO	LTC or VITC (automatically switched)
VITC	VITC recorded on tape

#### Output time code

The setting of setup menu item 606 determines whether the time code output from the TIME CODE OUT connector is the time code generated by the internal time code generator (REGEN), or the playback time code (TAPE).

### 4-1-2 Playback Procedures

This section describes the following types of playback which the unit can carry out:

- Normal playback  
Playback at normal ( $\times 1$ ) speed
- Playback in jog mode  
Variable speed playback, with the speed determined by the speed of turning the search dial
- Playback in shuttle mode  
Variable speed playback, with the speed determined by the angular position of the search dial
- Playback in variable speed mode  
Variable speed playback, with the speed finely determined by the angular position of the search dial
- Playback using the capstan override function  
The playback speed is adjusted temporarily according to the angular position of the search dial, to align the playback phase with that of another VTR.
- DMC Playback  
Playback carried out at memorized varying speed.

### Normal playback

First insert a cassette.

For details of how to insert a cassette, see Section 3-4-2 "Inserting and Ejecting Cassettes" (page 3-6).

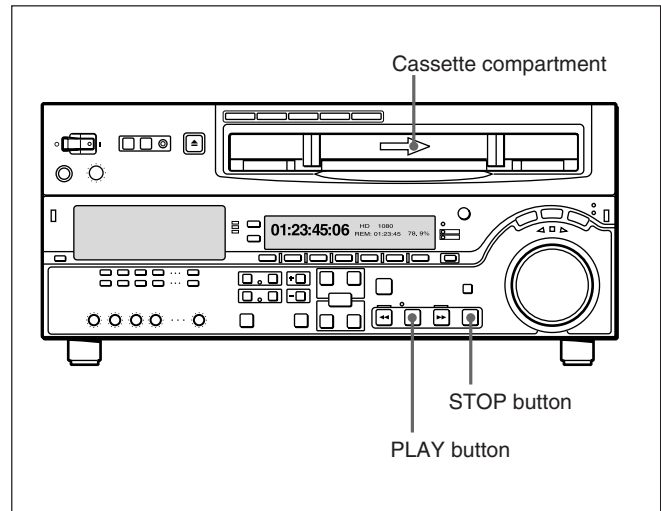

#### To start playback

Press the PLAY button.  
Playback starts, the servo locks, and the SERVO indicator lights.

#### To stop playback

Press the STOP button.

#### If you play back to the end of the tape

The tape is automatically rewound, and stops.

*It is possible to disable the automatic rewind function by changing the setting of setup menu item 125.*

## Playback in jog mode

In jog mode, you can control the speed of playback by the speed of turning the search dial. The playback speed range is  $\pm 1$  times normal speed.

*The playback speed range can be  $\pm 3$  times normal speed by changing the setting of setup menu item 116.*

To carry out playback in jog mode, use the following procedure.

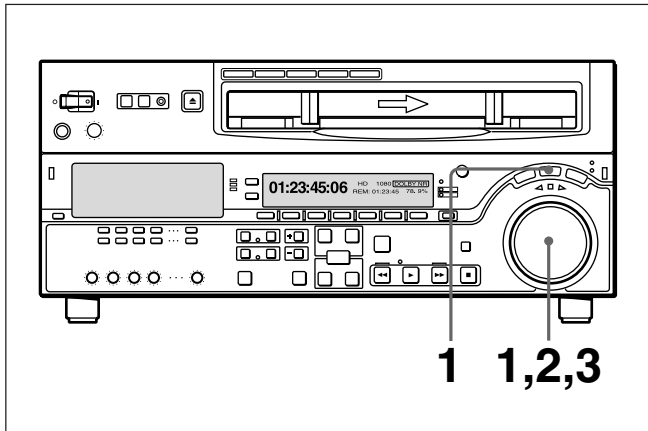

- 1 Press the JOG button or search dial so that the JOG button is lit.

Pressing the search dial toggles between jog mode and shuttle mode.

- 2 Turn the search dial in the desired direction, at the speed corresponding to the desired playback speed.

Playback in jog mode starts.

- 3 To stop playback in jog mode, stop turning the search dial.

*The function to toggle between jog mode and shuttle mode each time the search dial is pressed can be disabled by changing the setting of setup menu item 101.*

## Playback in shuttle mode

In shuttle mode, you can control the speed of playback by the angular position of the search dial. The range of playback speed is as follows.

- HDCAM tape:  $\pm 50$  times normal speed (59.94i, 29.97PsF mode),  $\pm 58$  times normal speed (50i, 25PsF mode),  $\pm 60$  times normal speed (24PsF, 23.98 PsF mode)
- Digital Betacam tape:  $\pm 50$  times normal speed
- MPEG IMX tape:  $\pm 78$  times normal speed
- Betacam SX tape:  $\pm 78$  times normal speed
- Analog Betacam tape:  $\pm 35$  times normal speed (525/59.94 mode),  $\pm 42$  times normal speed (625/50 mode)

There are detents on the search dial at the still position and at  $\pm 5$  times normal speed.

To carry out playback in shuttle mode, use the following procedure.

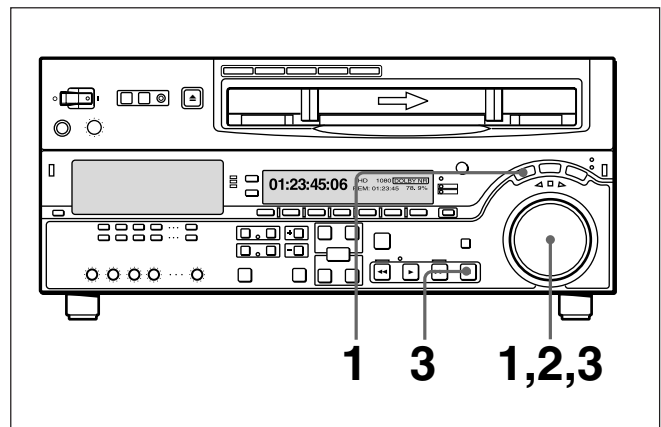

- 1 Press the SHUTTLE button or search dial so that the SHUTTLE button is lit.

Pressing the search dial toggles between jog mode and shuttle mode.

- 2 Turn the search dial to the desired angle corresponding to the desired playback speed.

Playback in shuttle mode starts.

- 3 To stop playback in shuttle mode, return the search dial to the center position, or press the STOP button.

*The function to toggle between jog mode and shuttle mode each time the search dial is pressed can be disabled by changing the setting of setup menu item 101.*

## 4-1 Playback

### To return to normal-speed playback

Press the PLAY button.

### To alternate between normal-speed playback and shuttle mode playback

Set the search dial to the position corresponding to the desired shuttle playback speed, then switch between normal-speed playback and shuttle playback by pressing the PLAY and SHUTTLE buttons alternately. For intermittent shuttle mode playback, press the STOP and SHUTTLE buttons alternately.

### Playback in variable speed mode

In variable speed mode, you can finely control playback speed within the following ranges:

- **HDCAM:** -1 to +2 times normal speed
- **Digital Betacam :** -1 to +3 times normal speed
- **MPEG IMX:** -1 to +3 times normal speed
- **Betacam SX:** -1 to +2 times normal speed
- **Betacam/Betacam SP:** -1 to +3 times normal speed

There are detents on the search dial at the still position and at  $\pm 1$  times normal speed.

To carry out playback in variable speed mode, use the following procedure.

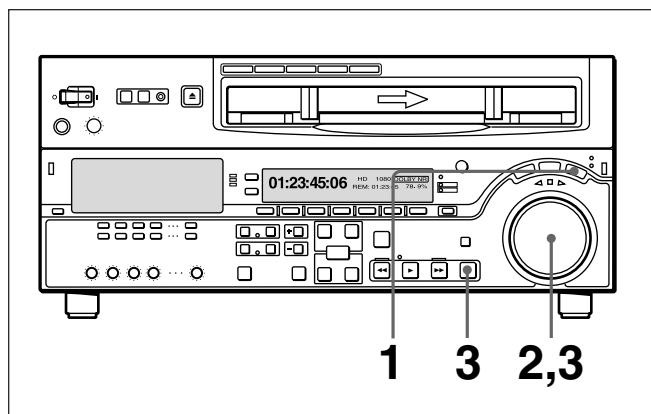

- 1** Press the VAR button, turning it on.
- 2** Turn the search dial to the desired angle corresponding to the desired playback speed.  
  
Playback in variable speed mode starts.
- 3** To stop playback in variable speed mode, return the search dial to the center position, or press the STOP button.

### To return to normal-speed playback

Press the PLAY button.

### To alternate between normal-speed playback and variable speed mode playback

Set the search dial to the position corresponding to the desired variable playback speed, then switch between normal-speed playback and variable speed playback by pressing the PLAY and VAR buttons alternately. For intermittent variable speed mode playback, press the STOP and VAR buttons alternately.

### Playback using the capstan override function

You can use the capstan override function to adjust the playback speed temporarily. This function is convenient for playback phase synchronization with another VTR playing back the same program.

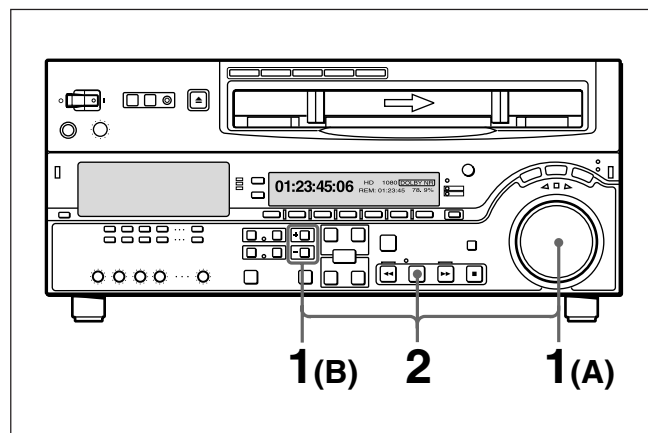

- 1** (A) Hold down the PLAY button, and turn the search dial in the desired direction to adjust the playback speed.  
The range of speed adjustment is  $\pm 15\%$  in steps of 1%.  
(B) Hold down the PLAY button, and press the TRIM buttons to adjust the playback speed. The playback speed can be adjusted to  $\pm 8\%$  only.

The SERVO indicator goes off.

- 2** When the adjustment is completed, release the PLAY button.

The tape transport returns to normal speed, and the SERVO indicator comes on again.

## To perform continuous capstan override playback

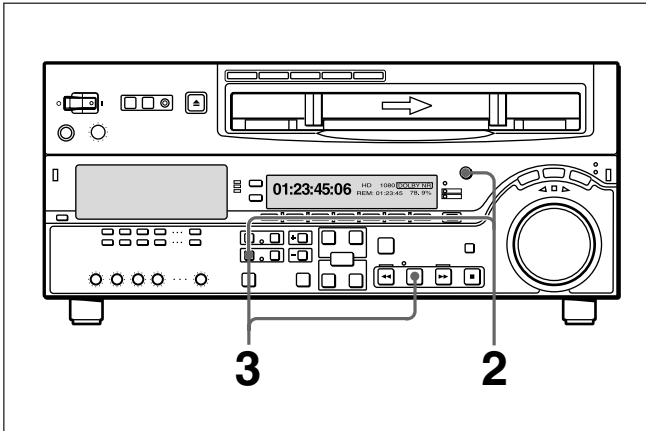

- 1** Set setup menu item 111 (TSO PLAY) to TSO.
- 2** Hold down the DMC EDIT button and turn the MULTI CONTROL knob to select the playback speed.  
  
The selected playback speed is displayed in time data display area 2 on the lower control panel of this unit as well as in the character information display on the monitor screen.
- 3** Press the PLAY button while holding down the DMC EDIT button.
- 4** Press the PLAY button or perform any other operation to exit the tape speed override mode.

See Section 9-2 "Setup Menu Operations" (page 9-2) for details of setup menu operations.

For details of character information displayed on the video monitor screen, see the descriptions of F4 (CHARA) in function menu page 4 (page 8-6) and setup menu item 005 (page 9-7).

## 4-1 Playback

### 4-1-3 Dynamic Motion Control (DMC) Playback

#### Overview

DMC playback allows you to vary the playback speed for a certain section of a tape, in variable speed mode and store the varying speed in memory for later playback at the same varying speed. For example, during a live broadcast of a sporting event you can set the start and end points of highlights

while recording, and then provide immediate DMC playback of those highlights.

During DMC playback the tape moves as shown in the following figure.

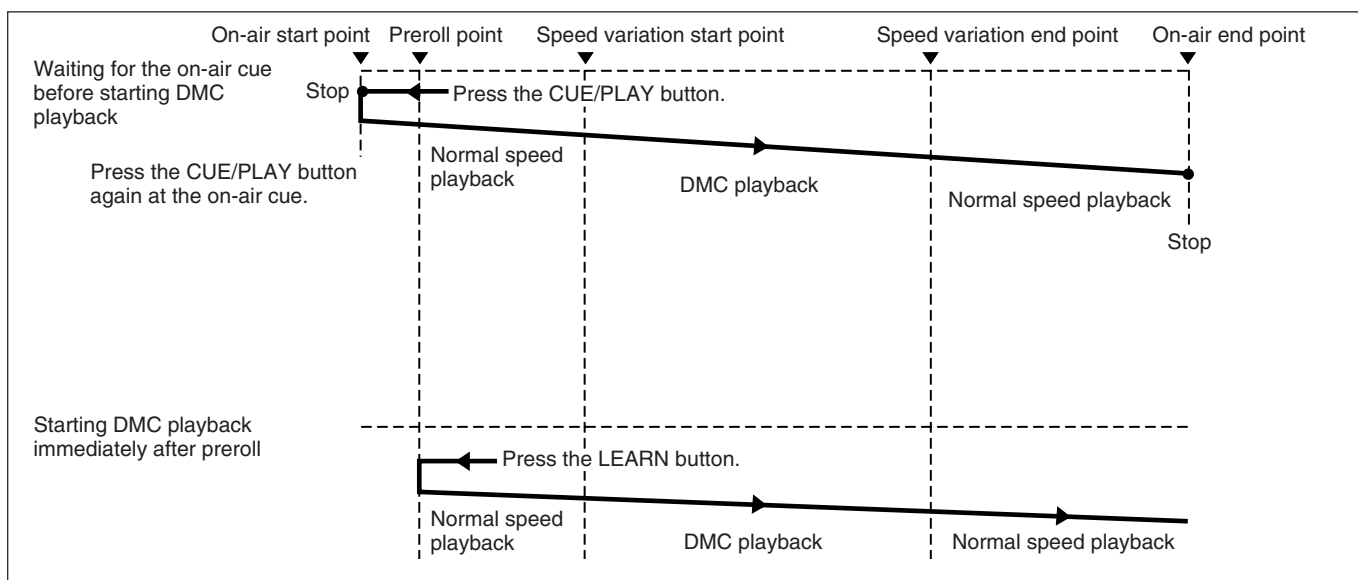

#### Storing a varying playback speed in memory

To store the playback speed for DMC playback, use the following procedure.

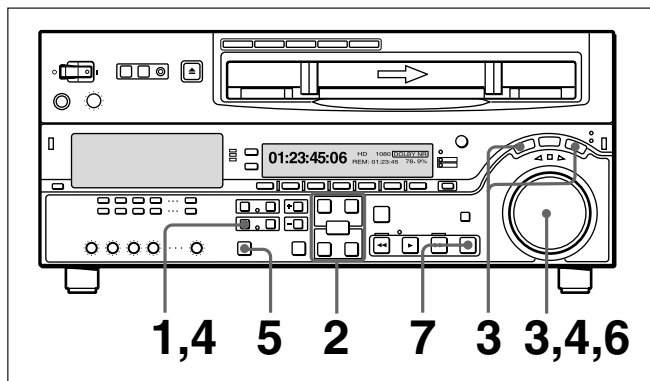

- 1 Press the DMC EDIT button, turning it on.
- 2 While playing back the recorded tape, press the ENTRY button and one of the following buttons simultaneously, to set the start and end points.
  - **On-air start point:** PLAY IN button
  - **Speed variation start point:** STUNT IN button
  - **Speed variation end point:** STUNT OUT button
  - **On-air end point:** PLAY OUT button

Each press turns the corresponding button on.

- 3** Press the search dial or the SHUTTLE button or VAR button to enter shuttle/variable speed mode.

The SHUTTLE/VAR indicator lights.

**Note**

Make sure that setup menu item 111 (TSO PLAY) is set to DIS.

- 4** Holding down the DMC EDIT button, turn the search dial, to set the initial speed at the playback start point.

The speed you set appears in the speed indication area. During this period the tape does not move. When the initial speed setting is complete, release the DMC EDIT button.

- 5** Press the LEARN button.

The tape is prerolled and played back at normal speed from the on-air start point to the speed variation start point. On passing the speed variation start point, the MEMORY indicator begins to flash, and playback begins at the speed set in step 4.

- 6** Turn the search dial to vary the playback speed.

While the MEMORY indicator is flashing, the speed variations are stored in memory. On passing the speed variation end point, the MEMORY indicator changes from flashing to continuously lit, and the variable speed storing ends.

- 7** Press the STOP button to stop the tape.

**If the MEMORY indicator lights continuously before the speed variation end point**

This indicates that the memory became full at that point. It is therefore not possible to memorize more speed variation. The maximum capacity is a duration of 120 seconds.

**To amend the stored speed variation**

Press the LEARN button.

The interval between the speed variation start and end points is automatically played back at the stored speed. Operate the search dial as required, to adjust the playback speed.

**Setting the initial speed to normal speed**

In step 4, press the PLAY button.

**Executing DMC Playback**

There are two methods of starting DMC playback.

- Starting playback at the on-air cue from the on-air start point
- Starting playback immediately after preroll

**Notes**

- To avoid operating mistakes we recommend that you use the VTR in standalone mode when carrying out DMC playback.
- When using two VTRs connected for editing, you can only use the recorder VTR for DMC playback, and only when neither the RECORDER nor PLAYER button is lit.

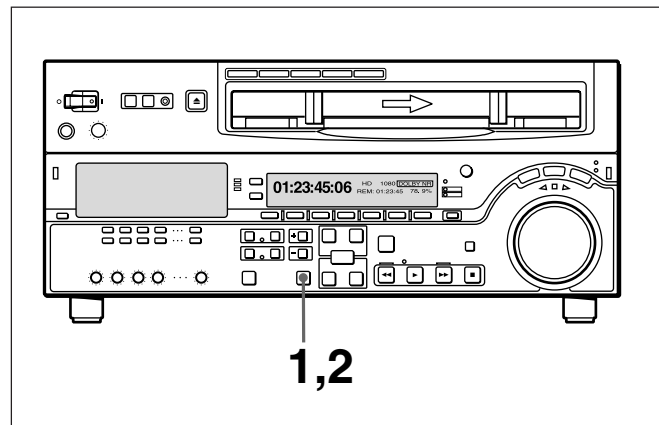

**To start playback at the on-air cue from the on-air start point**

Use the following procedure.

- 1** Press the CUE/PLAY button.

The CUE/PLAY button lights, and the tape is cued up to the on-air start point. After the tape is cued up, the CUE/PLAY button flashes.

- 2** At the moment the on-air cue is given, press the CUE/PLAY button once more.

The CUE/PLAY button lights, and playback starts at standard speed.

Between the speed variation start and end points, DMC playback is carried out at the stored speed, and then playback continues at normal speed and the tape stops at the on-air end point.



## 4-1 Playback

---

### **To start playback immediately after preroll**

Press the LEARN button.

The LEARN button lights, and after preroll, DMC playback is carried out for the section from the speed variation start point, then playback continues at normal speed from the speed variation end point.

### **To stop the tape during DMC playback**

Press the STOP button.

### **To exit DMC playback mode**

Press the DMC EDIT button and the DELETE button simultaneously.

## 5-1 Overview

This unit allows the use of shot marks. Shot marks are indications at desired points on a tape which enable faster cuing.

---

### Types of shot mark

On this unit, you can write post marks by a button operation during playback, while stopped, or during a search. It is possible to modify or erase the post marks. This chapter describes the use of shot marks including post marks.

First, the shot mark functions of this unit are described in simple terms.

---

### Reading shot marks

This unit reads in shot marks written on a tape and stores them in memory (to a maximum of 200). Once this data is stored in this unit, it is preserved even when the power is turned off.

---

### Writing and erasing shot marks

Post marks can be written at any point on a tape, and also erased or rewritten.

---

### Shot mark list operations

On the monitor, you can display a list of the shot marks read in by this unit, select required shot marks, delete shot marks, and so on. You can also add a memo mark (#) to a shot mark in the list. During tape playback, you can add virtual shot marks to the list. This is not written on the tape itself.

---

### Cuing up to shot marks

By selecting a desired shot mark from the shot mark list, you can cue up immediately to that position. By means of a button operation, you can also cue up to the shot marks adjacent to the current tape position (index function).

---

### Shot data display

When the tape includes shot data (camera, time, and other information captured at the time of shooting), you can read this in, and display the details on a monitor. It is also possible to display the shot mark list and shot data simultaneously.

---

### Sorting shot marks by cassette

When the tape includes shot data, this unit recognizes which cassette each shot mark comes from. You can therefore sort the read-in shot marks by cassette in time code order.

# 5-2 Shot Mark Operation Menu

This section describes the settings in the shot mark operation menu.

## Displaying the shot mark operation menu

With the function menu HOME page showing in the menu display, hold down the MARK button, and press the F5 (MENU) button.

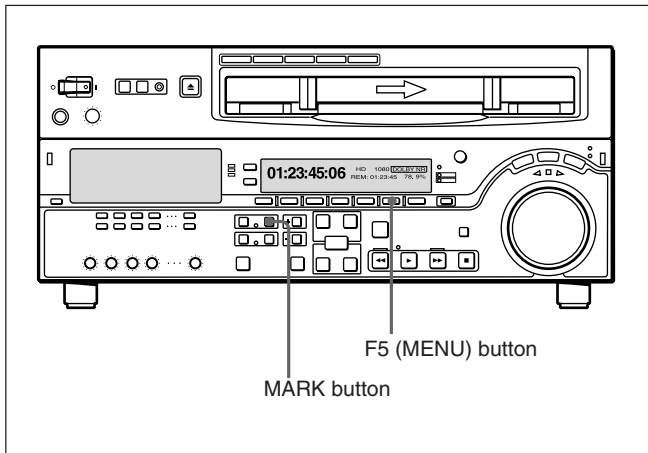

The following menu appears on the monitor.

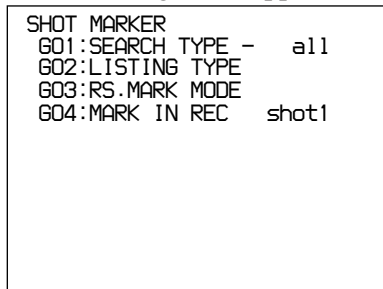

## Details of the shot mark operation menu

The shot mark operation menu comprises two items, G01 and G02. The detailed contents appear in the following table.

Item number	Item name	Settings
G01	SEARCH TYPE	Select which shot mark type the index function searches for, from the following possibilities: <b>all</b> <b>rec start mark</b> <b>shot mark 1</b> <b>shot mark 2</b> <b>post mark</b>
G02	LISTING TYPE	For each type of shot mark, select whether to read into the list (ON) or not read (OFF): <b>rec start mark</b> <b>shot mark 1</b> <b>shot mark 2</b> <b>post mark</b>

## Changing the menu settings

The basic procedure for accessing menu items and changing settings is the same as for the setup menus. Note, however, the operations in “To change the settings of menu items with sub-items” (page 9-3) for item G02.

*For details of the setup menu operations, see Section 9-2 “Setup Menu Operations”(page 9-2).*

# 5-3 Shot Mark Operations

This section describes the operations concerning reading and writing shot marks. Note that the following operations cannot be carried out by remote control.

## 5-3-1 Reading Shot Marks

### To read in shot marks

With a cassette loaded, hold down the LIST button and press the F FWD or REW button.

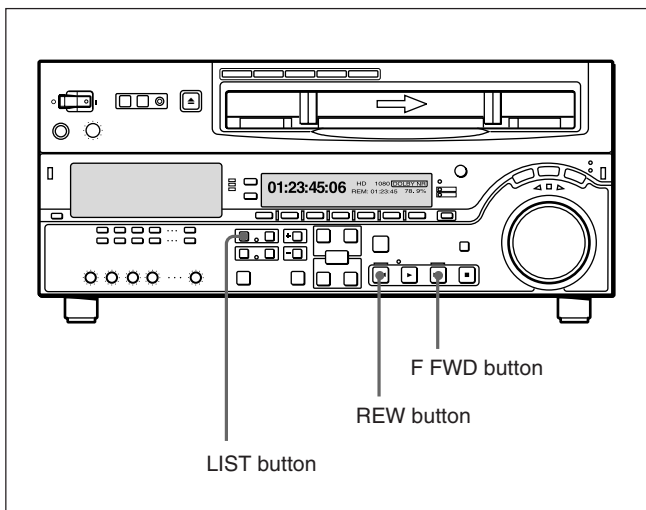

While the shot marks are being read in, the F FWD or REW button flashes.

The unit searches to the end of the tape, then rewinds automatically.

*For the procedure for listing the shot marks read in, see page 5-4.*

#### Note

It is only possible to read in a maximum of 200 shot marks.

When 200 shot marks have been read in, the control panel display shows the message "SHOT LIST FULL", and the reading stops.

To cancel the message, press one of the tape transport buttons.

### To stop reading

Press the STOP button.

### Reading shot marks from more than one cassette

After changing the cassettes, carry out the reading operation again.

Data written in the new cassette will be added as long as the total does not exceed 200 shot marks. For example, if 190 shot marks have already read in, only 10 shot marks will be read from the new tape.

In the shot mark list (*see page 5-4*) the data from different cassettes is separated by a row of dashes.

## 5-3-2 Writing Post Marks

When this unit is in any of the playback, stop, or search modes, you can write a post mark only.

- 1 Hold the MARK button down for at least 2 seconds.

The REC/ERASE indicator lights.

- 2 At the position you wish to write the mark, hold down the ENTRY button and press the MARK button.

A post mark is written the instant you pressed the MARK button.

While the mark is being written, the message "RECORD SHOT MARK" appears on the monitor, and the REC/ERASE indicator flashes.

### Erasing a shot mark

Select the shot mark from the shot mark list, and then carry out the deletion operation.

*For details of the procedure, see page 5-5.*

## 5-3 Shot Mark Operations

### 5-3-3 Shot Mark List Operations

#### Displaying the shot mark list

Hold down the ENTRY button and press the LIST button.

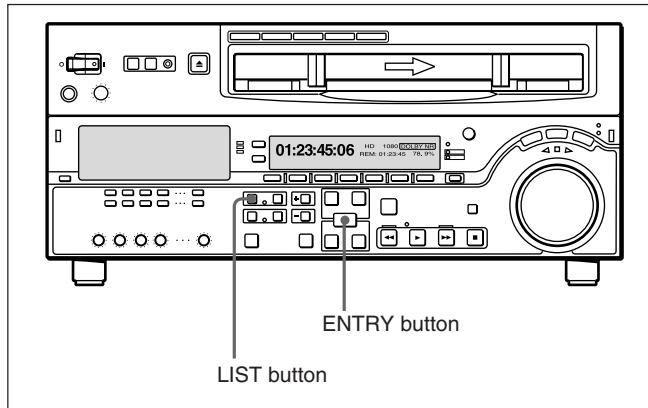

All of the shot mark types for which item G02 in the shot mark operation menu is set to “ON” appear in the list. If you do the same operation again, the list display disappears.

While the shot mark list is displayed, the function menu display changes as follows.

SHT						
MRK	MEMO	SELECT	DELETE		SETTING	EXIT

#### Example of list display

The following figure shows how the list is organized.

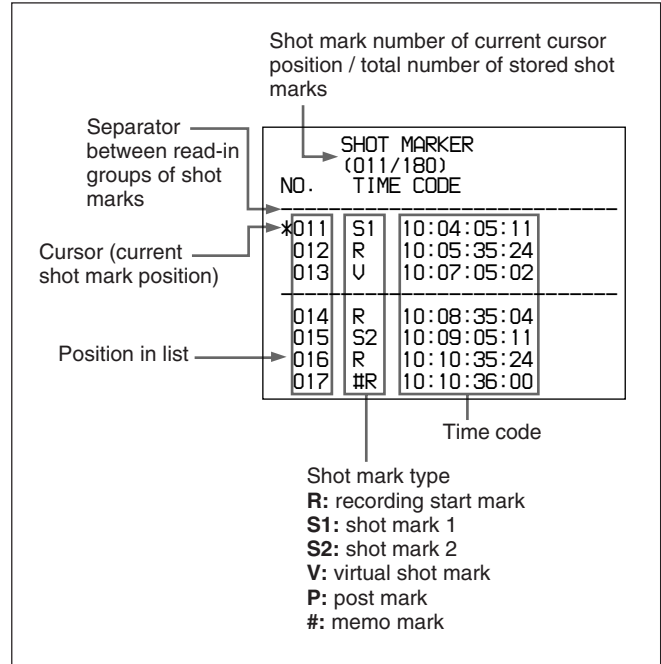

#### Selecting a shot mark

Turn the MULTI CONTROL knob to align the asterisk cursor with the desired shot mark.

#### Entering virtual shot marks

When the unit is stopped, performing playback, or searching, hold down the ENTRY button and press the MARK button.

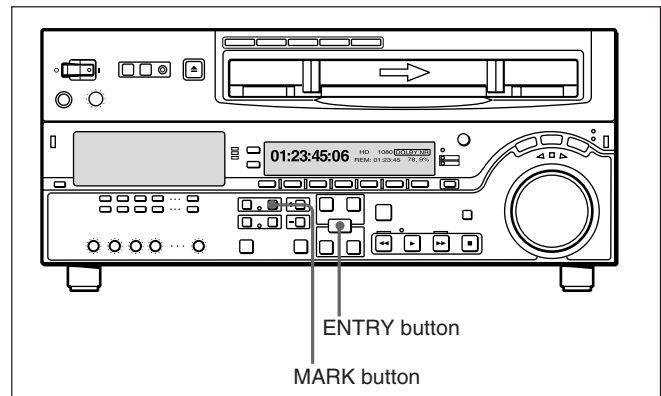

A virtual shot mark appears on the monitor as “V-MARK xxx” (xxx is the number). This is not written to the tape.

After entering a virtual shot mark, if you change the cassette or power the unit off, it appears in the list as the first shot mark of the next group read in.

### Adding a memo mark (#)

Select the shot mark to which you wish to add the memo mark, then press the F1 (MEMO) button. Repeat this operation to remove a memo mark.

### Selecting the types of shot mark to be read in the list

For each of the types of shot mark (recording start mark, shot mark 1, shot mark 2, and post mark) you can specify whether it is read in.

In item G02 of the shot mark operation menu, set the required types to “ON”.

*For details of the menu, see page 5-2.*

You can also use the following procedure.

- 1 With the shot mark list displayed, press the F5 (SETTING) button.

You can now select the shot mark types.  
The function menu display changes as follows.

SHT						
MRK	PREV	NEXT	OFF	ON		EXIT

- 2 Press the F1 (PREV) or F2 (NEXT) button to select a shot mark type.
- 3 Press the F4 (ON) or F3 (OFF) button to switch between ON (displayed) and OFF (not displayed).
- 4 To return to the shot mark list, press the F6 (EXIT) button.

### Deleting a shot mark from the list

To delete a shot mark or the shot mark list, you can use the F2 (SELECT) button instead of the MARK button, and the F3 (DELETE) button instead of the DELETE button.

### To delete an individual shot mark

Use the following procedure.

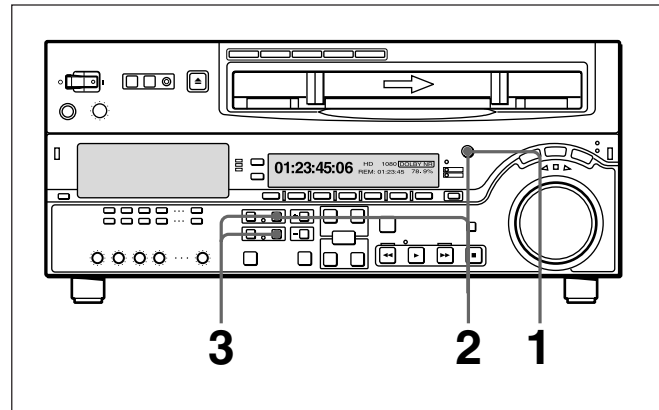

- 1 With the shot mark list displayed, select the shot mark to be deleted using the MULTI CONTROL knob.

- 2 Hold the MARK button down.

While you hold down the button, an “X” appears after the selected shot mark number, indicating that it will be deleted.

To delete more than one shot mark, while holding down the MARK button turn the MULTI CONTROL knob to select all of the shot marks.

- 3 With the MARK button held down, press the DELETE button.

This deletes the shot marks which were marked by an “X”.

### To delete the entire list

Hold down the DELETE button and press the LIST button.

This deletes all shot marks from the list. This does not erase marks from the tape.

### Erasing shot marks from the tape

To erase a shot mark, use the following procedure.

#### Note

Once you erase a shot mark from the tape, it cannot be read back in.

## 5-3 Shot Mark Operations

- 1 With no shot mark list displayed, hold the MARK button down for at least 2 seconds.

The REC/ERASE indicator lights, indicating that you can rewrite or erase shot marks.

- 2 Display the shot mark list.
- 3 Turn the MULTI CONTROL knob to select on the list the shot mark you wish to erase.
- 4 Press the DELETE button and MARK button simultaneously.

During the erasure process the message “ERASE SHOT MARK” appears, and the REC/ERASE indicator flashes.

- 5 When the shot mark has been erased, close the shot mark list.
- 6 Hold down the MARK button for at least 2 seconds, to turn off the REC/ERASE indicator.

### 5-3-4 Cuing Up to Shot Marks

#### Cuing up to a selected shot mark

Use the following procedure.

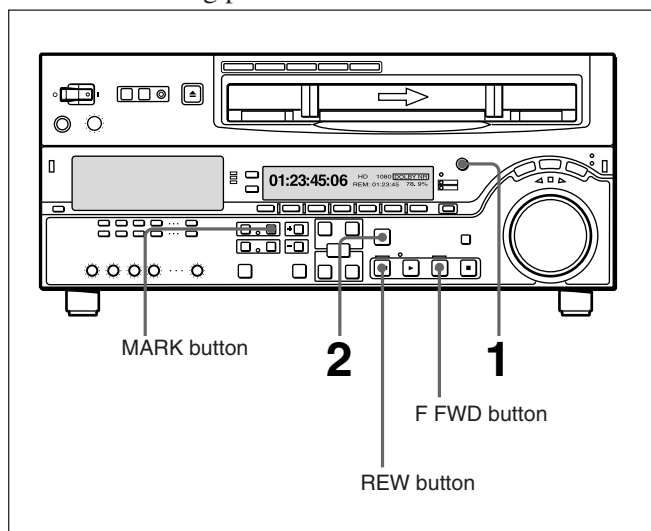

- 1 Turn the MULTI CONTROL knob to select the desired shot mark from the shot mark list.
- 2 Press the PREROLL button.

#### Cuing up to shot marks adjacent to the current tape position (index function)

- 1 In item G01 of the shot mark operation menu (page 5-2), select one of recording start mark, shot mark 1, shot mark 2, and post mark, or select all.
- 2 Holding down the MARK button, press the F FWD button or REW button.

While the tape is moving, the F FWD button or REW button flashes.

When the shot mark is detected, its type is displayed in time data display area 2 (page 2-7) on the lower control panel and in the character information display on the monitor screen.

For details of character information display on the monitor screen, see F4 (CHARA) in function menu page 4 (page 8-6) and setup menu item 005 (page 9-7).

#### Note

You cannot use the above procedure to cue up to a virtual shot mark.

### 5-3-5 Reading In Shot Data

When there is shot data (time, device, and other information about the shooting) written on the tape, you can read it in and display it on the monitor.

#### Displaying the shot data

Holding down the ENTRY button, press the PLAY button.

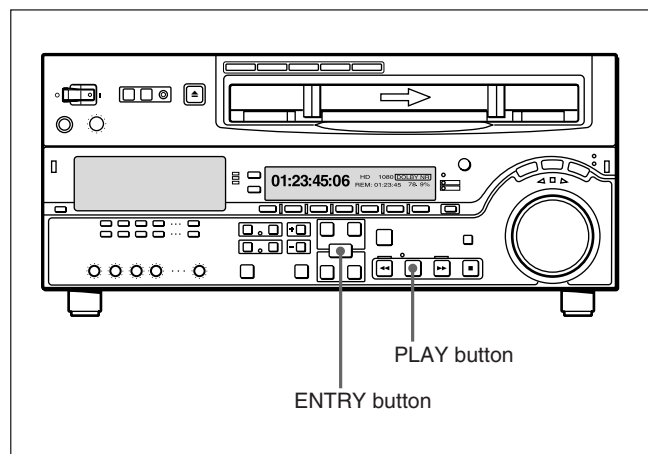

The tape is played back, and the shot data displayed.

**To delete the shot data**

Once again hold down the ENTRY button, and press the PLAY button.

**Example of shot data display**

The shot data display appears as shown below.

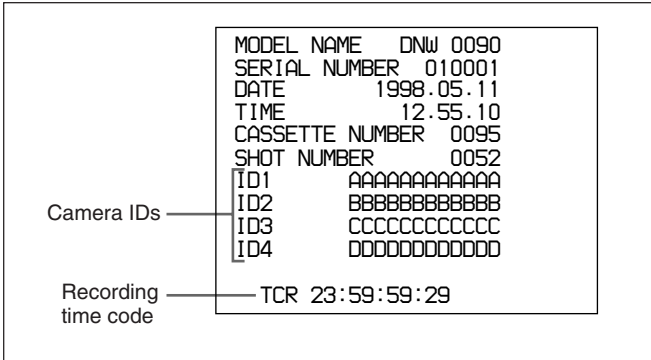

The details in the shot data depend on the shooting conditions. If because of the devices used there is no shot data on a part of the tape, it appears as blank.

**Displaying the shot data on the shot mark list**

Turn the MULTI CONTROL knob to position the cursor on a separator in the shot mark list. If there is shot data recorded when the immediately following shot mark was written, it appears in the display as shown below.

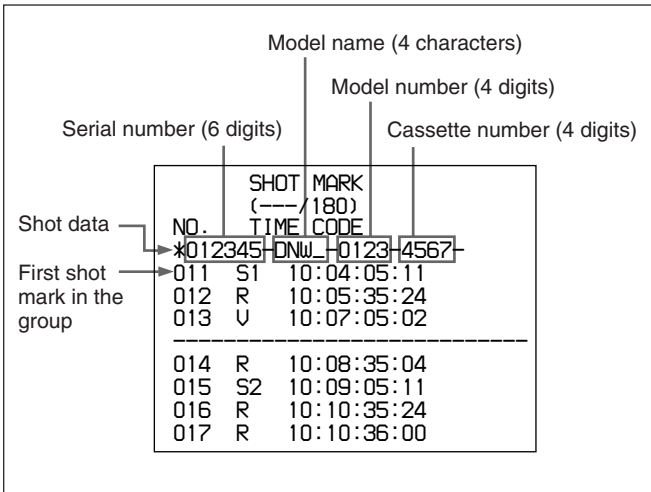

You can sort the shot marks in the list, based on the shot data. For details, see the next section.



## 5-3 Shot Mark Operations

### 5-3-6 Sorting Shot Marks

Based on shot data recorded on the tape, you can separate the shot marks by cassette, and sort them in time code sequence.

#### To sort the shot marks

Use the following procedure.

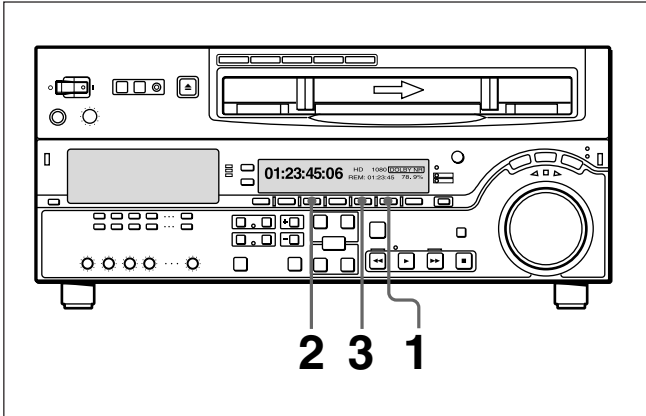

- 1** With the shot mark list displayed, press the F5 (SETTING) button.
- 2** Press the F2 (NEXT) button, and select SORTING LIST.
- 3** Press the F4 (ON) button to change the setting to ON.

Sorting starts. When it ends, the setting indication returns to OFF.

For example, if shot marks have been read in twice from the same cassette, these can be collated as shown in the following figure.

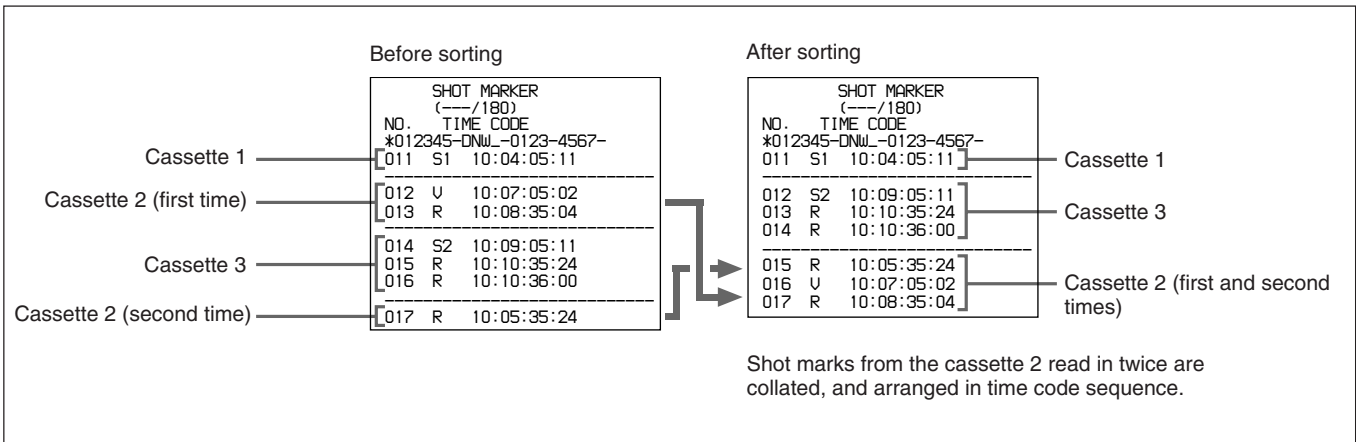

## 6-1 Overview of Tele-File Functions

Tele-File is a non-contact data carrier system. Tele-File enables data writing/reading between cassettes with memory labels and VTRs. It increases the efficiency of operations such as cuing up and playback, and source data management.

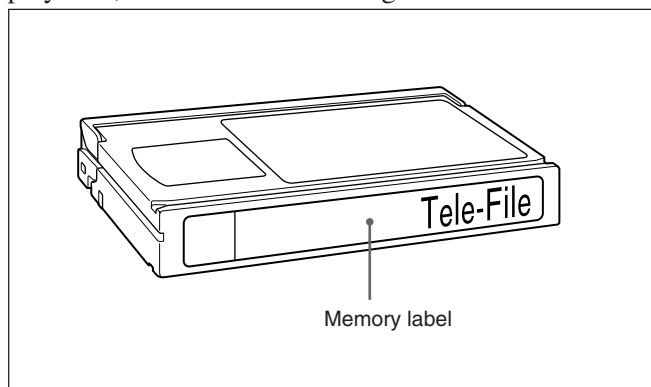

### Newly developed IC

The Tele-File system employs a newly developed memory IC with the following features.

- Thin design: With a thickness of 0.5 mm, the IC can be attached to cassettes as a memory label.
- Memory capacity: 1 KB (user area, rewritable)
- Data transfer speed: 100 kbps
- Security functions: Reading and writing authorization can be controlled through multiple passwords and permission settings.

### Data management in clip units

In Tele-File, data is managed in units called “clips.” A clip consists of the following data items, whose settings can be displayed and changed.

- Cue point
- Write protect
- Mark
- Recording start point
- IN point
- OUT point
- Take number
- Cut number
- Scene number
- Comment

### Data library management with handy reader/writer

An optional handy reader/writer (supporting Memory Stick) is available to facilitate data library management.

# 6-2 Opening the Tele-File Menu

## Opening from the function menu

Display page 5 of the function menu in the menu display section, and then press the F1 (TELE-F) button.

The Tele-File menu opens.

*For details about the function menu, see Chapter 8 "Function Menu" (page 8-1).*

## Opening automatically

When setup menu item 134 is set to ON, and when the current function menu page is HOME, HOME2, or page 1 to page 6, the Tele-File menu opens automatically whenever a Tele-File label is detected on a cassette loaded into the VTR.

*For details about setup menu item 134, see Section 9-4 "Items in the Extended Setup Menu" (page 9-12).*

## Configuration of the Tele-File menu

The Tele-File menu has a tree structure, as illustrated below.

When the menu first opens, the menu operations mode is clip data display mode.

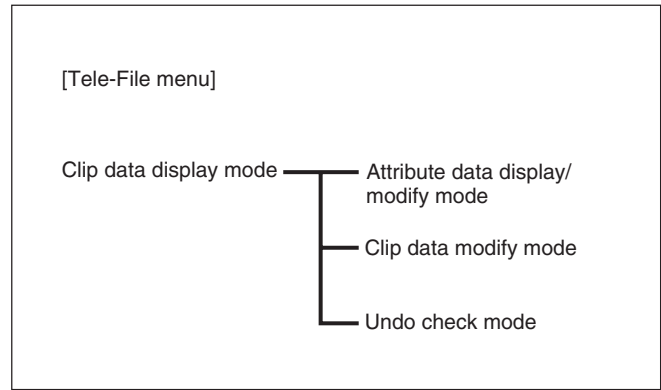

# 6-3 Tele-File Menu

## 6-3-1 Clip Data Display

### How to read the display

Shown below are examples of the default menu displays in the menu display section and the monitor display.

For more information about how to display menus on the monitor, see the section "To display menus on the monitor" (page 9-2).

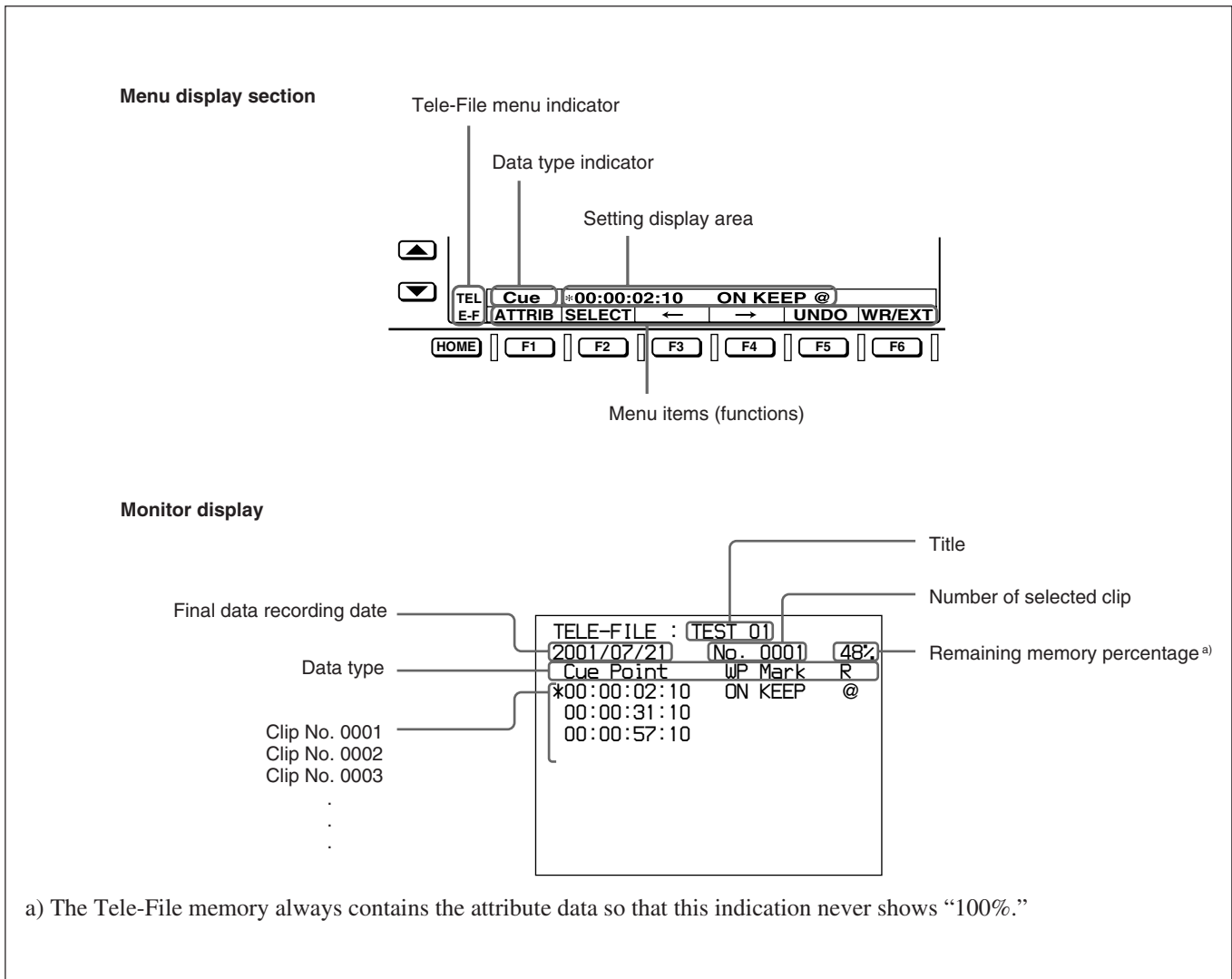

### Menu display section

#### Tele-File menu indicator

Indicates that the menu display section is currently displaying the Tele-File menu.

#### Data type indicator

Indicates the type of data selected with the clip data display mode. There are the following types.

**Cue:** Cue point

**Protct:** Write protected

**Mark:** Mark

**R-Strt:** Recording start point

**IN:** IN point

**OUT:** OUT point

**Take:** Take number

**Cut:** Cut number

**Scene:** Scene number

**Comnt:** Comment

## 6-3 Tele-File Menu

### Setting display area

Displays the setting of the currently selected data type, and a cursor (“\*” or “>”).

The meaning of the cursor symbols is as follows:

- \*: Indicates that the mode is clip data display mode or attribute data display/modify mode, and that data is selected.
- >: Indicates that the mode is clip data modify mode or attribute data display/modify mode, and prompts for data entry or modification.

### Menu items (functions)

Display menu items (functions).

These are common for all of the data items in clip data display mode. The function assignments for each item are as follows.

Clip data display mode menu items

Item name	Setting
F1 (ATTRIB)	Selects attribute data display/modify mode.  <i>For details about attribute data display/modify mode, see Section 6-3-5 “Displaying and Modifying Attribute Data” (page 6-11).</i>
F2 (SELECT)	Selects a data modification mode for the data selected in the clip. The cursor changes from “*” to “>”.  <b>Note</b> In the following cases, the SELECT item does not appear, and it is not possible to select a data modification mode. <ul style="list-style-type: none"> <li>• When setup menu item 133 is set to REMOTE</li> <li>• When the memory label itself is write protected</li> </ul> <i>For more information about clip data modifications, see Section 6-3-3 “Modifying Clip Data” (page 6-7).</i>
F3 (←)	Selects data in a clip. With each press, the “*” cursor moves to select the previous data item. The display scrolls to the left when the cursor moves to data that is not currently displayed.
F4 (→)	Selects data in a clip. With each press, the “*” cursor moves to select the next data item. The display scrolls to the right when the cursor moves to data that is not currently displayed.
F5 (UNDO)	Selects undo check mode. This button appears and is enabled when data has been modified after being read from the Tele-File label.  <i>For more information about undo check mode, see Section 6-3-4 “Undo/Resume Functions” (page 6-10).</i>
F6 (WR/EXT)	Writes data and exits from the Tele-File menu (return to function menu page 5).

### Note

If you attempt to change clip data that is write-protected, the message “PROTECTED CLIP!” appears, and it is not possible to change the data. Refer to “To make write protect, mark, and recording start point settings” (page 6-9), and remove the write-protect setting.

## Monitor display

### Title

The title (maximum 14 characters) set in attribute data display/modify mode.

### Selected clip number

A 4-digit number representing the number of the selected clip (with the "\*" cursor).

### Remaining memory percentage

The percentage of remaining memory (user area) available for use.

If there is not sufficient free memory, the message <<MEMORY FULL!!>> appears (stays lit for three seconds) in time data display area 2 when you attempt to add data.

### Final data recording date

The data (year/month/day) on which data was most recently recorded.

### Data type

The data type. The displayed data is the same as the data displayed in the menu display section, but some of the captions are different. There are the following types.

- Cue Point:** Cue point
- WP:** Write protected
- Mark:** Mark
- R:** Recording start point
- IN Point:** IN point
- OUT Point:** OUT point
- Tk:** Take number
- Cut:** Cut number
- Scn:** Scene number
- Comment:** Comment

### Clip data No. 0001...

Data is displayed for 1 clip per line.  
Clips are assigned consecutive numbers, beginning with No. 0001 for the clip on the top line.

## To select clips

Rotate the MULTI CONTROL knob in clip data display mode.

The data for the selected clip appears in the menu display section, where it is selected.

In the monitor display, the "\*" cursor moves up and down as clips are selected.

Data which is not visible is selected and displayed after scrolling.

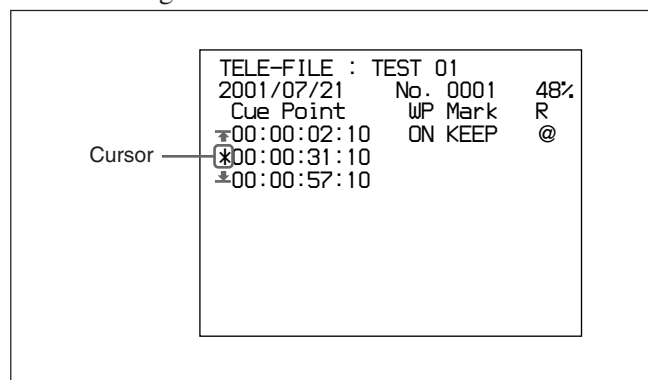

## To select data in a clip

In clip data display mode, press the F3 (←) or F4 (→) button.

The "\*" cursor moves and data is selected. Data which is not visible is selected and displayed after scrolling.

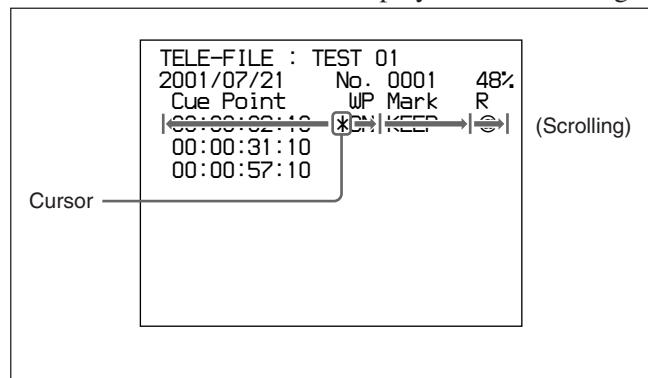

## 6-3 Tele-File Menu

---

### Moving the cursor directly

Regardless of the cursor's current position, pressing one of the following buttons moves the cursor directly to the specified position in the same clip and displays the data.

**IN (video IN point) button:** IN point data

**OUT (video OUT point) button:** OUT point data

**MARK button:** Cue point data

### To display the duration

Press the IN (video IN point) and OUT (video OUT point) buttons simultaneously. The cursor moves to the IN point data of the same clip, and the duration appears while the buttons are held down. If there is no IN point or OUT point data, the duration is displayed as 0:00:00:00.

### 6-3-2 Preroll and Cue Up Using Clip Data

In clip data display mode, you can use clip data to preroll and cue up.

### To preroll to the cue point, IN point, or OUT point

- 1 Select a clip.
- 2 Select the cue point, the IN point, or the OUT point.
- 3 Press the PREROLL button.

The unit exits from the Tele-File menu and prerolls to the position of the selected data.

The preroll time is according to the setting of setup menu item 001.

#### Note

The unit does not preroll if there is no data for the selected point.

### To cue up the cue point, IN point, or OUT point

- 1 Select a clip.
- 2 Press the PREROLL button while holding down the IN (video IN point), OUT (video OUT point), or MARK button.

The unit exits from the Tele-File menu and cues up the position of the data selected in step 2 (the cue point position if the MARK button was pressed).

#### Note

The unit does not preroll if there is no data for the selected point.

### 6-3-3 Modifying Clip Data

To modify clip data, put the unit into clip data display mode and then press the F2 (SELECT) button to put it into clip data modification mode (the cursor changes to “>”).

The function assignments for menu items in clip data modification mode are as follows.

Clip data modification mode menu items

Item name	Setting
F1 (RETURN)	Returns to clip data display mode.
F2 (MODIFY)	Changes the setting of the selected data, or makes a new setting. The function button changes according to the data type.  <i>See the following for more information about how to set the various data types.</i> <ul style="list-style-type: none"> <li>• Cue point, IN point, OUT point: “To set time code data” (page 6-8)</li> <li>• Write protect, mark, recording start point: “To make write protect, mark, and recording start point settings” (page 6-9)</li> <li>• Take number, cut number, scene number: “To make take number, cut number, and scene number settings” (page 6-9)</li> <li>• Comment: “To make comment settings” (6-10)</li> </ul>
F3 (DELETE)	Deletes the data setting value. Enabled when cue point, IN point, OUT point, take number, cut number, scene number, or comment data is selected. A confirmation message appears. Press one of the following buttons to confirm or cancel the operation. <ul style="list-style-type: none"> <li>• F1 (CANCEL): Cancels the deletion and returns to clip data display mode.</li> <li>• F2 (OK): Executes the deletion and returns to clip data display mode.</li> </ul>
F4 (DEL LN)	Deletes the selected clip. A confirmation message appears. Press one of the following buttons to confirm or cancel the operation. <ul style="list-style-type: none"> <li>• F1 (CANCEL): Cancels the deletion and returns to clip data display mode.</li> <li>• F2 (OK): Executes the deletion and returns to clip data display mode.</li> </ul>
F5 (INS LN)	Inserts a clip at the cursor position. A confirmation message appears. Press one of the following buttons to confirm or cancel the operation. <ul style="list-style-type: none"> <li>• F1 (CANCEL): Cancels the insertion and returns to clip data display mode.</li> <li>• F2 (OK): Executes the insertion and returns to clip data display mode.</li> </ul>
HOME + F4 (DELETE ALL)	Deletes all clips. A confirmation message appears. Press one of the following buttons to confirm or cancel the operation. <ul style="list-style-type: none"> <li>• F1 (CANCEL): Cancels the deletion and returns to clip data display mode.</li> <li>• F2 (OK): Executes the deletion and returns to clip data display mode.</li> </ul>

#### Note

If you attempt to change clip data that is write-protected, the message “PROTECTED CLIP!” appears, and it is not possible to change the data. Refer to “To make write protect, mark, and recording start point settings” (page 6-9), and remove the write-protect setting.



## 6-3 Tele-File Menu

---

### To add and delete clips

#### To add clips

**1** Rotate the MULTI CONTROL knob to move the “\*” cursor to the position where you want to insert the clip.

**2** Press the F2 (SELECT) button.

The unit enters clip data modification mode.

**3** Press the F5 (INS LN) button.

A confirmation message “INSERT CLIP OK?” appears.

**4** Press the F2 (OK) button.

The clip is added at the position to which you moved the cursor in step **1**.

#### To delete clips

**1** Select the clip to delete.

**2** Press the F2 (SELECT) button.

The unit enters clip data modification mode.

**3** Press the F4 (DEL LN) button.

A confirmation message “DELETE THIS CLIP OK?” appears.

**4** Press the F2 (OK) button.

The clip selected in step **1** is deleted.

### To set time code data

Proceed as follows to make or change settings for cue point, IN point, and OUT point data.

**1** Select a clip.

**2** Select cue point, IN point, or OUT point.

**3** Press the F2 (SELECT) button.

The unit enters clip data modification mode.

**4** Press the F2 (MODIFY) button.

The two most significant digits begin to flash, and the data can be set or modified.

**5** Press the F3 (←) or F4 (→) button until the digit that you want to set starts flashing.

**6** Rotate the MULTI CONTROL knob to make the setting.

#### To display the offset from the previous setting value

The offset is displayed as long as you hold down the F2 (OFFSET) button.

**7** Repeat steps **5** and **6** until you have set all the required digits.

**8** Press the F5 (SET) button.

The setting is confirmed and the unit returns to clip data display mode.

#### To cancel the setting or modification and return to clip data display mode

Press the F1 (CANCEL) button.

---

### To set the set or modified data as other time data

Press the F6 (SET TO) button and select the time data (cue point, IN point, or OUT point), and then press the F5 (SET) or F6 (SET NL) button. The position where the data is set differs as follows, depending on the button pressed.

- **F5 (SET):** The data is set in the selected time data position.
- **F6 (SET NL):** A new clip is added at the lowest line and the time data is set at the selected data position in the new clip.

---

### To make write protect, mark, and recording start point settings

Proceed as follows to make write protect, mark, and recording start point settings.

- 1** Select a clip.
- 2** Select write protect, mark, or recording start point.
- 3** Press the F2 (SELECT) button.

The unit enters clip data modification mode.

- 4** Press the F2 (MODIFY) button.

The data entry area begins to flash, and the data can be set.

- 5** Select the data by pressing the F3 (+) or F4 (-) button or rotating the MULTI CONTROL knob.
- 6** Press the F2 (SET) button.

The data setting is confirmed and the unit returns to clip data display mode.

---

### To make take number, cut number, and scene number settings

Proceed as follows to make take number, cut number, and scene number settings.

- 1** Select a clip.
- 2** Select take number, cut number, or scene number.
- 3** Press the F2 (SELECT) button.

The unit enters clip data modification mode.

- 4** Press the F2 (MODIFY) button.

The most significant digit begins to flash, and the data can be set.

- 5** Press the F3 (←) or F4 (→) button until the digit that you want to set starts flashing.
- 6** Rotate the MULTI CONTROL knob to make the setting.
- 7** Repeat steps **5** and **6** until you have set all the required digits.
- 8** Press the F2 (SET) button.

The setting is confirmed and the unit returns to clip data display mode.

### To make comment settings

Proceed as follows to make comment settings.

- 1** Select a clip.
- 2** Select comment.
- 3** Press the F2 (SELECT) button.  
  
The unit enters clip data modification mode.
- 4** Press the F2 (MODIFY) button.  
  
The data entry area begins to flash, and the data can be set.
- 5** Enter a character by rotating the MULTI CONTROL knob.
- 6** Press F4 (→) button to move to the next character place.
- 7** Repeat steps **5** and **6** until you have entered the entire comment.

#### To delete characters

Press the F3 (←) or F4 (→) button until the character that you want to delete starts flashing, and then press the F5 (DELETE) button.

#### To insert characters

Press the F3 (←) or F4 (→) button until the character place after the place where you want to insert starts flashing, and then press the F6 (INSERT) button.

- 8** Press the F2 (OK) button.

The comment is confirmed and the unit returns to clip data display mode.

### 6-3-4 Undo/Resume Functions

#### Undo function

The undo function cancels all modifications and returns the data to the state it was in when first read. Press the F5 (UNDO) button in clip data display mode. A confirmation message appears. Press the F2 (OK) button to execute the undo and cancel all modifications to the data.

#### Resume function

If you have not modified any data since the last execution of the undo function, you can press the F5 (UNDO) button again. The button functions as a resume button, which cancels the immediately preceding undo. Press the F5 (UNDO) button in clip data display mode. A confirmation message appears. Press the F2 (OK) button to execute the resume and cancel the immediately preceding undo.

## 6-3-5 Displaying and Modifying Attribute Data

You can display and modify attribute data. The example below shows attribute data displayed on the monitor.

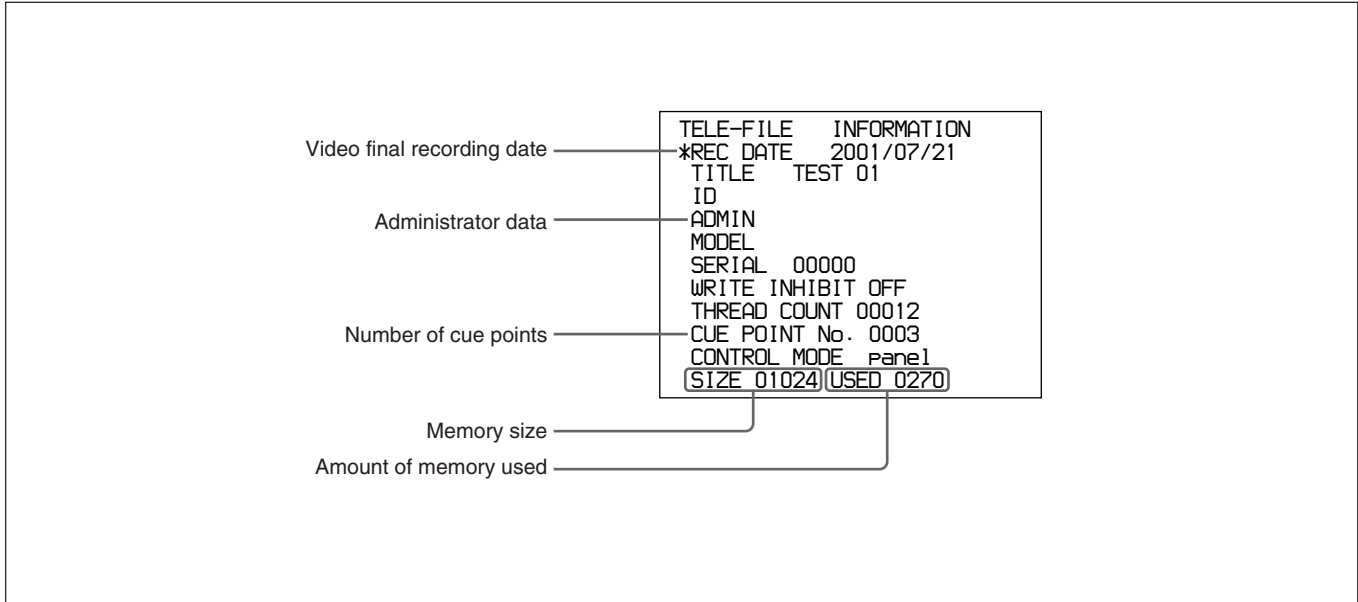

### Video final recording date

The most recent date (year/month/day) on which video was recorded on the tape.

### Title

The title (name assigned to Tele-File, etc., maximum 24 characters).

The title can be modified.

### ID

The ID (unique number assigned to Tele-File, maximum 24 characters).

The ID can be modified.

### Administrator data

Data about the administrator of the cassette or tape material (maximum 16 characters).

The administrator data can be modified.

### Model name

The model name of the VTR that recorded most recently to the tape.

### Serial number

The serial number of the VTR that recorded most recently to the tape.

### Write inhibit setting

Whether the entire Tele-File is write inhibited. The write inhibit setting can be modified.

### Thread count

The thread count value recorded on the tape.

### Number of cue points

The number of cue points recorded in the Tele-File. You can check the cue point values in clip data display mode.

### Control mode

The setting of menu item 133.

*For more information about menu item 133, see page 9-12.*

### Memory size

The size of the memory in the Tele-File (unit: bytes).

### Amount of memory used

The amount of memory currently being used (unit: bytes).

## 6-3 Tele-File Menu

---

### To modify attribute data

You can modify the title, ID, administrator data, and write inhibit setting attributes.

However, the attributes cannot be modified when the control mode is “remote.” The modification is not possible when the write inhibit setting is ON, either. Proceed as follows after setting the write inhibit setting to OFF.

- 1 Rotate the MULTI CONTROL knob to select the item.

The F2 (SELECT) button is enabled when you select an item that can be modified (title, ID, administrator data, and write inhibit setting).

- 2 Press the F2 (SELECT) button.

The data can be set or modified.

- 3 Rotate the MULTI CONTROL knob to set or modify the data.

- 4 Press the F2 (SET) button.

The change to the setting is confirmed.

#### Note

In the following cases, the SELECT item does not appear, and it is not possible to select a data modification mode.

- When setup menu item 133 is set to REMOTE
- When the memory label itself is write protected

### To format the Tele-File memory

You can format the Tele-File memory (erase all modifiable data). However, the memory cannot be formatted in the following cases.

- When the write inhibit setting is ON
- When the control mode is “remote”

To format Tele-File memory, proceed as follows.

- 1 Press the F4 (FORMAT) button.

A confirmation message appears.

- 2 Press the F2 (OK) button.

All modifiable data is erased.

#### Note

In the following cases, the FORMAT item does not appear, and it is not possible to select a data modification mode.

- When setup menu item 133 is set to REMOTE
- When the memory label itself is write protected

## 7-1 Overview of UMID Functions

The UMID (Unique Material Identifier) is a type of meta-data in video and audio materials. It has been internationally standardized in SMPTE Standard 330M. This unit supports recording and generation of UMIDs.

The UMID is made up of a section called the “Basic” section and a section called the “Source Pack” section. The Basic section contains information such as the device that recorded the material and whether the

material is the original or a copy. The Source Pack section contains information about when/where/who recorded the material.

A UMID with a Basic section only is called a Basic UMID. A UMID with both Basic and Source Pack sections is called an Extended UMID. The following figure shows a general overview of the information contained in a UMID.

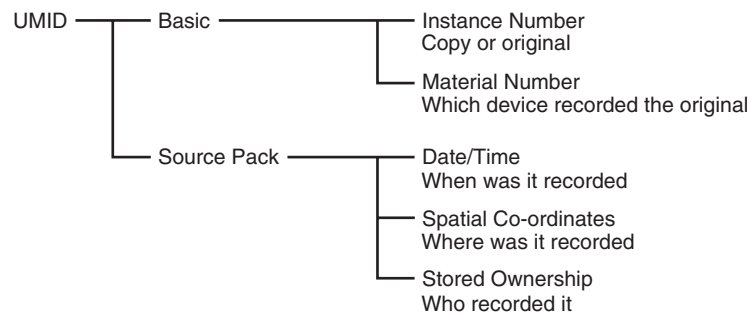

# 7-2 UMID Output and Display

This section explains how to output and display UMIDs.

**Note**

When the number of active scan lines for HD SDI output is set to 720P, output and displaying of UMID are not carried out.

## 7-2-1 UMID Output Settings

You can choose to output UMIDs or not, and select either Basic UMID or Extended UMID when you choose to output UMIDs. Make these settings using setup menu item 651 UMID OUTPUT. (UMID information is added to HD SDI output.)

See page 9-18 for more information about setup menu item 651.

## 7-2-2 UMID Display

During recording and playback, UMID data appears in the menu display section of the control panel and on the video monitor.

### To display the UMID

In function menu page 5, press the F2 (UMID) button.

See Section 8-1-2 “Using the Function Menu” (page 8-2) for more information about function menu operations.

The UMID appears in the menu display section of the control panel and on the video monitor.

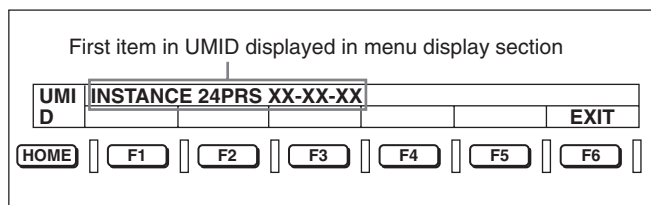

See the next section “UMID display on the video monitor” for examples of the UMID displayed on the video monitor.

### To switch the displayed UMID item in the menu display section

Rotate the MULTI CONTROL knob.

### To exit from UMID display

Press the F6 (EXIT) button.

## UMID display on the video monitor

The video monitor connected to the COMPOSITE VIDEO OUTPUT 3 (SUPER) connector or the SDI OUTPUT 3 (SUPER) connector on the connector panel displays all UMID items at once. The display of each line is explained below.

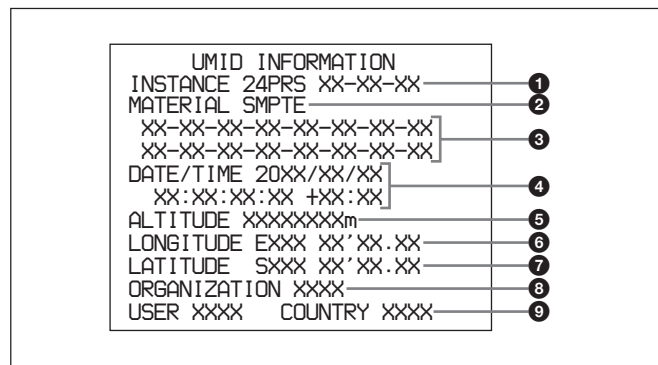

### 1 Instance Number generation method and Instance Number

The generation method is displayed as follows.

- CP+16:** “16-bit PRS (pseudo-random sequence) +Copy No.” method
- 24PRS:** 24-bit PRS method
- others:** Other than the above

When menu item 656 MATERIAL NO. is set to NEW, the SMPTE method is used.

### 2 Material Number generation method

- SMPTE:** SMPTE method
- IEEE 1394 ZONE:** IEEE 1394 ZONE method
- IEEE 1394 RND:** IEEE 1394 RND method
- others:** Other than the above

### 3 Material Number

The material number is displayed in hexadecimal across two lines.

The following items, 4 through 9, are contained in the Source Pack.

### 4 Date/Time

Date/Time data is displayed across two lines. The upper line shows the MJD (Modified Julian Date) contained in the Source Pack, converted to UTC. The lower line shows the data in unit count format (hours : minutes : seconds : frame) converted to UTC.

## Note

The function for converting unit count to UTC works only when the unit rate is 2 (24 frames), 3 (24/1.001 frames), 4 (25 frames), 6 (30 frames), or 7 (30/1.001 frames). For other unit rates, the unit rate number and unit rate are displayed in hexadecimal.

## 5 Altitude

**XXXXXXXXm**: Altitude data indicating the distance from the center of the earth is displayed in this format.

**S+XXXXXXXXm Y+D**: Altitude data indicating the distance from sea level is displayed in this format. The meaning of the characters and strings shown is as follows.

- “S” (1st character): Indicates data from a Sensor. “R” is shown for position data from the recording device (Recorder), and “T” is shown for Target position data.
- “+” (2nd character): Indicates higher than sea level. “-” indicates lower than sea level.
- “XXXXXXXXm” : Altitude data (unit meters).
- “Y”: The number of satellites used to calculate position data (hexadecimal).
- “D”: DOP (dilution of precision) value.
- “+” (between Y and D): Displayed when a supportive apparatus was used. A space (blank) is displayed when no supportive apparatus was used.

## 6 Longitude

Following “W” to indicate west longitude or “E” to indicate east longitude, the longitude is displayed in degrees, minutes, and seconds (seconds are shown up to 2 decimal places).

Example: “E134 59’23.00” for “East longitude 134 degrees 59 minutes 23.00 seconds”

## 7 Latitude

Following “N” to indicate north latitude or “S” to indicate south latitude, the latitude is displayed in degrees, minutes, and seconds (seconds are shown up to 2 decimal places).

Example: “N34 59’23.32” for “North latitude 34 degrees 59 minutes 23.32 seconds”



# 8-1 Overview

The function menu allows you to make frequently made settings, such as selection of input video signals and time code settings.

## 8-1-1 Function Menu Configuration

The function menu consists of seven pages by factory default: the HOME page and six pages numbered 1 to 6. You can also display the HOME2 page by setting user-defined function keys. The following icons appear at the left edge of the menu display section to denote the current page.

- 🏠 1: HOME page
- 📄 1: Page 1
- 📄 2: Page 2
- 📄 3: Page 3
- 📄 4: Page 4
- 📄 5: Page 5
- 📄 6: Page 6
- 🏠 2: HOME 2 page

Each page has a menu display section made up of an upper and lower part. The upper part displays the menu items (functions) in the page, and the lower part displays the menu item settings. The figure below shows the menu display section in the HOME page.

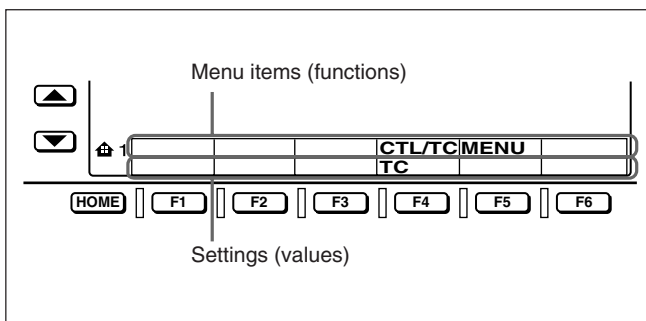

In the figure above, TC (time code) is selected as the setting for CTL/TC (time data selection), the menu item for button F4. This manual refers to this as “F4 (CTL/TC) in function menu HOME page is set to TC.”

## HOME2 page (user-defined function keys)

Up to six function keys can be defined (i.e. six functions can be assigned to the F1 to F6 buttons in the HOME2 page).

You can select and define the following function keys:

- Functions selected from the function menu items in the HOME page and menu pages 1 to 4
- Function key to display the setting for setup menu item 211 (REMOTE1 PORT) and to carry out the operation when the menu item setting is “panel”.

### Note

By factory default, no function keys are defined in the HOME2 page.

It is not possible to display the HOME2 page unless you have defined at least one function key in that page.

*For details on defining user-defined function keys in the HOME2 page, refer to the Maintenance Manual Volume 1.*

## Page 6

You can define up to six setup menu items (assign six setup menu items to the F1 to F6 buttons) and register them on page 6.

### Note

There is nothing defined on page 6 when the unit is shipped from the factory.

*For more information about defining setup menu items for page 6, refer to the Maintenance Manual Volume 1.*

## 8-1 Overview

---

### 8-1-2 Using the Function Menu

---

#### To change a menu item setting

To change a menu item setting, press the corresponding function button (F1 to F6) to display the desired setting in the lower part of the menu display. Each press of the button displays the next setting.

---

#### When a menu item setting flashes

Menu item settings flash to inform you that you can change the setting value by rotating the MULTI CONTROL knob.

---

#### To change the function menu page

Press either of the page buttons (▼, ▲).

- The ▼ button selects the next page in the order HOME→1→2→3→4→5→6→HOME...
- The ▲ button selects the next page in the order HOME→6→5→4→3→2→1→HOME...

---

#### Settings which do not appear in the menu display section

In the HOME page (*see the figure in Section 8-1-1 “Function Menu Configuration”*), the settings for F5 (MENU) do not appear in the menu display. When you press the F5 or F6 button, the whole menu page changes to allow you to make settings.

# 8-2 Function Menu Item List

The function menu has the following items.

## HOME page

Item	Setting
F4 (CTL/TC)	Selects the time data to display in time data display area 1 (see page 2-6). <b>TC:</b> Playback time code read by the internal time code reader. The LTC or VITC time data type indicator (see page 2-6) lights. <sup>a)</sup> <b>UB:</b> User bits data of playback time code. The LUB or VIUB time data type indicator lights, depending on whether the time code is LTC or VITC. <sup>a)</sup> <b>CTL:</b> The running time of the tape being played back, as calculated from a count of CTL signals recorded on the tape. The time is displayed in Hours:Minutes:Seconds:Frames format.
F5 (MENU)	Puts the system into setup menu mode (see Chapter 9). When the current setup menu settings are the same as the contents of any of menu banks 1 to 3, or the factory defaults, the corresponding indication (1), (2), (3), (4), or (dflt) appears. <b>(1):</b> Same as menu bank 1. <b>(2):</b> Same as menu bank 2. <b>(3):</b> Same as menu bank 3. <b>(4):</b> Same as menu bank 4. <b>(dflt):</b> Same as factory defaults.

a) The selection of LTC or VITC depends on the setting of F6 (TCR) in function menu page 1 .

## Page 1

Item	Setting
F4 (DF)	In 59.94i, 29.97PsF mode, selects either drop-frame mode or non-drop frame mode for the time code generator and the CTL counter. <b>DF:</b> Drop-frame mode <b>NDF:</b> Non-drop frame mode
F6 (TCR)	Selects the type of time code to display in the time data display. <b>LTC:</b> Display LTC. <b>AUTO:</b> Display VITC when tape speed is 1/2 or less of normal speed, and LTC otherwise. <b>VITC:</b> Display VITC.

## 8-2 Function Menu Item List

### Page 2

Item	Setting
F1 (V.PROC)	<p>Selects the control method for the internal digital video processor.</p> <p><b>LOCAL:</b> Change the settings of the internal digital video processor by using this function menu.</p> <p><b>REMOTE:</b> Use the optional BVR-50/50P Remote Control Unit to control the internal digital video processor.</p> <p><b>MENU:</b> Change the settings of the internal digital video processor by using F5 (MENU) of the HOME page.</p> <p><b>Note</b></p> <p>When controlling the unit from the HKDV-503/900, set this item to MENU.</p>
F2 (VIDEO)	<p>Sets the HD/SD video signal output level (<math>-\infty</math> to +3 dB).</p> <p><b>PRESET:</b> Regardless of manually set values, the video signal is set to the standard level.</p> <p><b>Manual setting:</b> With the displayed setting flashing, you can rotate the MULTI CONTROL knob to adjust the value for the video signal output level.</p>
F3 (CHROMA)	<p>Sets the HD/SD chroma signal output level (<math>-\infty</math> to +3 dB).</p> <p><b>PRESET:</b> Regardless of manually set values, the chroma signal is set to the standard level.</p> <p><b>Manual setting:</b> With the displayed setting flashing, you can rotate the MULTI CONTROL knob to adjust the value for the chroma signal output level.</p>
F4 (HUE) (59.94i, 29.97PsF mode)/(C PHAS) (50i, 25PsF, 23.98PsF, 24PsF mode)	<p>Sets the color phase (phase relative to burst)</p> <p><b>PRESET:</b> Regardless of manually set values, sets the color phase to the standard value.</p> <p><b>Manual setting:</b> With the displayed setting flashing, you can rotate the MULTI CONTROL knob to adjust the value across the range <math>\pm 30^\circ</math>.</p>
F5 (SETUP) (59.94i, 29.97PsF mode)/(BLACK) (50i, 25PsF, 23.98PsF, 24PsF mode)	<p>Sets the setup level (59.94i, 29.97PsF mode) or black level (50i, 25PsF, 23.98PsF, 24PsF mode)</p> <p><b>PRESET:</b> Regardless of manually set values, the level is set to the standard value.</p> <p><b>Manual setting:</b> With the displayed setting flashing, you can rotate the MULTI CONTROL knob to adjust the setup level across the range <math>\pm 30</math> IRE (59.94i, 29.97PsF mode) or to adjust the black level across the range <math>\pm 210</math> mV (50i, 25PsF, 23.98PsF, 24PsF mode).</p>
F6 (YC DLY)	<p>Sets amount of Y/C delay for playback of analog Betacam tapes.</p> <p><b>PRESET :</b> Regardless of manually set values, the Y/C delay is set to the standard value.</p> <p><b>Manual setting:</b> With the displayed setting flashing, you can rotate the MULTI CONTROL knob to adjust the Y/C delay across the range <math>\pm 100</math> ns.</p>

Item	Setting
F1 (SYNC)	<p>Sets the HD output signal sync phase.</p> <p><b>Setting method</b>            With the displayed setting flashing, you can rotate the MULTI CONTROL knob to adjust the output signal sync phase across the range <math>\pm 15 \mu\text{s}</math> relative to this unit's input reference signal.</p> <p>Adjust this item when you want to adjust the output signal sync phase precisely to match a reference signal, or when connecting this unit and other VTRs to a device such as a switcher to perform operations such as special effects editing.</p>
F2 (SC)	<p>Sets the HD output signal sync phase.</p> <p><b>Setting method</b>            With the displayed setting flashing, you can rotate the MULTI CONTROL knob to adjust the output signal phase across the range <math>\pm 200 \text{ ns}</math> relative to this unit's input reference signal.</p>
F4 (EMPHSS)	<p>Specifies whether to add audio emphasis to analog audio input signals and Betacam/Betacam SP format playback audio signals.</p> <p><b>ON:</b> Add audio emphasis.  <b>OFF:</b> Do not add audio emphasis.</p>
F5 (T INFO)	<p>Selects the type of time data to display in time data display area 2.</p> <p><b>TOTAL:</b> Display total time.  <b>REMAIN:</b> Display remaining time.</p>

## 8-2 Function Menu Item List

### Page 4

Item	Setting
F1 (CAPSTN)	<p>Selects the number of fields for capstan lock in playback.</p> <p><b>In 59.94i, 29.97PsF mode</b></p> <p><b>2F:</b> The capstan servo locks in units of 2 fields. When playing back a tape that was recorded with composite source signals, a vertical shift in the video (H shift) occurs. (When setup menu item 712 is set to ON.)</p> <p><b>4F:</b> The capstan servo locks in units of 4 fields. Even when playing back a tape that was recorded with composite source signals, no vertical shift in the video (H shift) occurs. You should set this menu item to this setting when continuity in video phase across edit points is required for composite signal playback or when carrying out A/B roll editing.</p> <p><b>In 50i, 25PsF mode</b></p> <p><b>2F:</b> The capstan servo locks in units of 2 fields. When playing back a tape that was recorded with composite source signals, a vertical shift in the video (H shift) occurs. (When setup menu item 712 is set to ON.)</p> <p><b>4F:</b> The capstan servo locks in units of 4 fields. When playing back a tape that was recorded with composite source signals, a vertical shift in the video (H shift) occurs. (When setup menu item 712 is set to ON.)</p> <p><b>8F:</b> The capstan servo locks in units of 8 fields. Even when playing back a tape that was recorded with composite source signals, no vertical shift in the video (H shift) occurs. You should set this menu item to this setting when continuity in video phase across edit points is required for composite signal playback or when carrying out A/B roll editing.</p> <p><b>Note</b></p> <p>The setting is automatically fixed at 2F when operating in 24PsF or 23.98PsF mode, and this cannot be changed.</p>
F3 (DOLBY)	<p>When using oxide tapes, specifies whether or not to use the Dolby type C low-frequency noise reduction (NR) system.</p> <p><b>NR ON :</b> Use the Dolby NR system when playing back analog Betacam oxide tapes.</p> <p><b>NR OFF :</b> Do not use the Dolby NR system when playing back analog Betacam oxide tapes.</p>
F4 (CHARA)	<p>Specifies whether or not to superimpose time code, menu settings, error messages, and so on over the video signals output to the HDSDI OUTPUT3(SUPER) connector, SDI OUTPUT3(SUPER) connector and COMPOSITE VIDEO OUTPUT3(SUPER) connector.</p> <p><b>ON:</b> Superimpose.</p> <p><b>OFF:</b> Do not superimpose.</p>
F5 (RECINH)	<p>Specifies whether or not to inhibit recording shot marks to tape.</p> <p><b>ON:</b> Inhibit recording to tape.</p> <p><b>OFF:</b> Do not inhibit recording to tape.</p>

### Page 5

Item	Setting
F1 (TELE-F)	<p>Displays the Tele-File menu.</p> <p><i>For details of the Tele-File menu, see Section 6-3 "Tele-File Menu" (page 6-3).</i></p>
F2 (UMID)	<p>Displays UMID information during playback.</p> <p><i>For details of UMID, see Chapter 7.</i></p>

# 9-1 Setup Menu Configuration

This unit has the following setup menus.

- Basic setup menu
- Extended setup menu

To access the extended setup menu, a setting on the internal SS-89 board is required.

*For details, refer to the Installation Manual.*

In this manual, both the basic setup menu items and extended setup menu items are also referred to simply as setup menu items or menu items.

## Configuration of the basic setup menu

The basic setup menu comprises the following groups of items.

Item group	Function	Refer to
Items H01 to H14	Display of the total number of hours the unit has been powered on, and other information collected by the digital hours meter	Page 10-5
Items 001 to 019	Settings relating to the preroll time, superimposed text information, system frequency, etc.	Page 9-7
Items B01 to B20	Settings relating to the menu banks for saving menu settings	Page 9-9

## Configuration of the extended setup menu

The extended setup menu comprises the following groups of items.

Item group	Function	Refer to
Items 100 to 199	Settings relating to control panels	Page 9-10
Items 200 to 299	Settings relating to the remote control interface	Page 9-13
Items 300 to 399	Settings relating to editing operations	Page 9-14
Items 400 to 499	Settings relating to preroll	Page 9-15
Items 500 to 599	Settings relating to tape protection	Page 9-16
Items 600 to 650	Settings relating to the time code generator	Page 9-16
Items 651 to 699	Settings relating to the UMID	Page 9-18
Items 700 to 799	Settings relating to video control	Page 9-19
Items 800 to 899	Settings relating to audio control	Page 9-23
Items 900 to 999	Settings relating to digital processing	Page 9-25

# 9-2 Setup Menu Operations

## To display setup menus

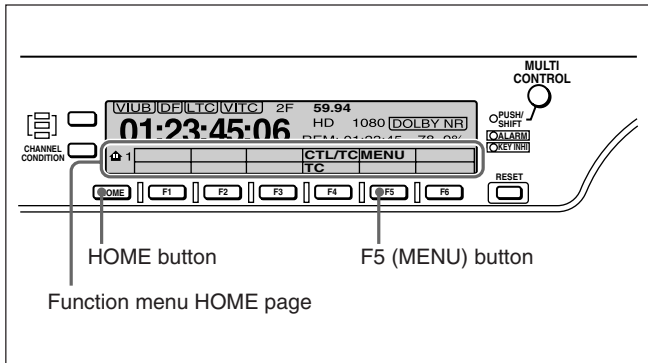

With the function menu HOME page showing in the menu display, press the F5 (MENU) button. The currently selected setup menu item is displayed in the menu display, with the menu item number flashing.

For basic operations in the menu display, see page 2-5.

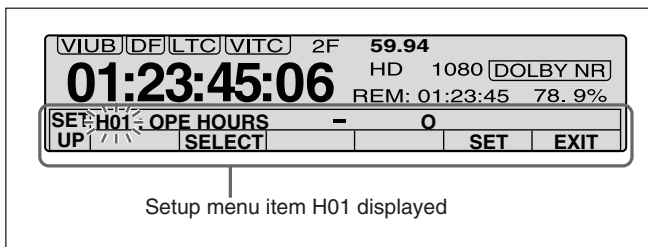

## To display menus on the monitor

Setting F4 (CHARA) to ON in function menu page 4 allows you to display setup menus on the monitor connected to the COMPOSITE VIDEO OUTPUT 3(SUPER) connector, HDSDI OUTPUT 3(SUPER) connector or SDI OUTPUT 3(SUPER) connector of this unit. When a setup menu appears on the monitor, a cursor indicates the currently selected menu item.

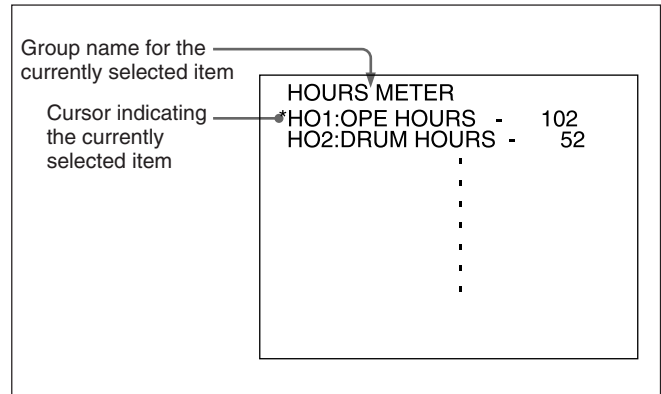

## Displaying a desired menu item

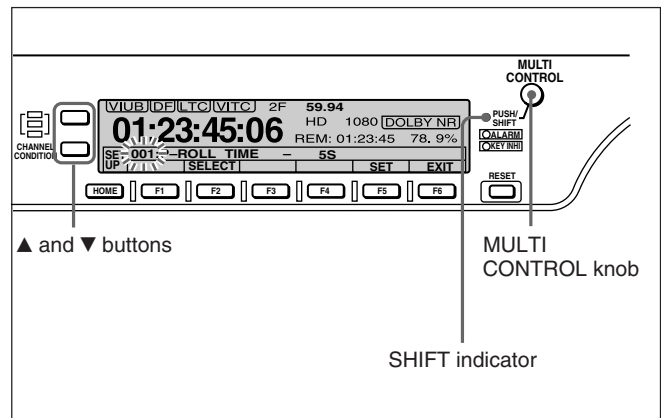

When the menu item number displayed in the menu display is flashing, you can change the menu item by turning the MULTI CONTROL knob. To skip from one item group to the next, press the ▲ button or ▼ button.



### **To display a desired sub-item**

For a menu item having sub-items, you can select a desired sub-item as follows.

- 1** With a desired menu item selected, press the F2 (SELECT) button.

The currently selected sub-item name flashes.

- 2** Turn the MULTI CONTROL knob to select a desired sub-item.

---

### **Changing menu item setting values**

The procedures for changing menu item setting values or sub-item setting values are described below.

#### **To change the settings of menu items without sub-items**

After selecting a desired menu item using the procedure described in the section “Displaying a desired menu item” on page 9-2 and with the menu item number flashing, proceed as follows.

- 1** Press the F2 (SELECT) button.  
  
The current setting of the menu item flashes.
- 2** Press the F3 (–) button or F4 (+) button, or turn the MULTI CONTROL knob to select a desired setting value.

#### **To select another menu item and change its setting value**

Press the F1 (RETURN) button making the current menu item number flash, then perform the procedures for selecting a desired menu item and changing its setting value.

- 3** When all required changes have been made, press the F5 (SET) button.

This makes the new settings effective.

#### **To abandon making changes and exit from the setup menu display**

Press the F6 (EXIT) button.

### **To change the settings of menu items with sub-items**

When a selected menu item has sub-items, select a desired sub-item using the procedure described in the section “To display a desired sub-item” on this page making the sub-item name flash, then proceed as follows.

- 1** Press the F2 (SELECT) button.

The current setting of the sub-item flashes.

- 2** Press the F3 (–) button or F4 (+) button, or turn the MULTI CONTROL knob to select a desired setting value.

#### **To select another sub-item and change its setting value**

Press the F1 (RETURN) button making the current sub-item name flash, then perform the procedures for selecting a desired sub-item and changing its setting value.

#### **To select another menu item and change its setting value**

Press the F1 (RETURN) button twice in succession making the current menu item number flash, then perform the procedures for selecting a desired menu item and changing its setting value.

- 3** When all required changes have been made, press the F5 (SET) button.

This makes the new settings effective.

#### **To abandon making changes and exit from the setup menu display**

Press the F6 (EXIT) button.

## 9-2 Setup Menu Operations

### Resetting the menu settings to their factory default values (menu item B20)

To reset the current active menu settings to their factory default values, proceed as follows.

- 1 Perform steps **1** to **3** of the procedure described in the section “To change the settings of menu items without sub-items” on page 9-3 to set menu item B20 RESET SETUP to ON.

The current active menu settings are reset to their factory default settings.

- 2 Press the F5 (SET) button again.

This saves the menu settings.

### Switching the system frequency (menu item 013)

To switch the system frequency between 59.94i, 50i, 29.97PsF, 25PsF, 24PsF, 23.98PsF, proceed as follows.

#### Notes

- Before carrying out this operation, consult the person responsible for system installation.
- When the unit is used in 50i, 25PsF mode, analog tape can only be played back in the simple playback mode.
- When this unit is put into 24PsF or 23.98PsF mode, SDI (D1), component, and composite signals are not output.

- 1 Perform steps **1** to **3** of the procedure described in the section “To change the settings of menu items without sub-items” on page 9-3 to set menu item 013 SYSTEM FREQUENCY SELECT to ON.

The menu display changes to allow switching of the system frequency between 59.94i, 50i, 29.97PsF, 25PsF, 24PsF, 23.98PsF.

- 2 Switch the setting, then press the F5 (SET) button.

- 3 Turn the unit off.

The next time the unit is turned on, it will operate in the new mode.

### Switching the line conversion function (menu item 018)

This operation is valid in 59.94i, 29.97PsF mode only. It is not available in other mode.

To change the line conversion (OFF TAPE/1035/1080/720P), use the following procedure.

#### Notes

- Consult with the administrator responsible for system installation before carrying out the following procedure.
- For the setting of the line conversion (see next item, “Line conversion mode”), setup menu item 916 ACTIVE LINE 1035 CONVERT MODE is valid in 1035-line mode, and setup menu item 917 ACTIVE LINE 1080 CONVERT MODE is valid in 1080-line mode.

- 1 Perform steps **1** to **3** of the procedure described in the section “To change the settings of menu items without sub-items” on page 9-3, to set setup menu item 018 ACTIVE LINE SELECT to ON.

The menu display changes to allow switching of the setting for line conversion between OFF TAPE, 1035, 1080, and 720P.

- 2 Select OFF TAPE, 1035, 1080, or 720P, then press the F5 (SET) button.

- 3 Turn the unit off.

The next time the unit is turned on, it will operate in the new mode.

## Line conversion mode

Use the following procedure.

### When setup menu item 018 ACTIVE LINE SELECT is set to 1035

Select the conversion mode in setup menu item 916 ACTIVE LINE 1035 CONVERT MODE.

**1080 ⇒ 1035 (CONV):** Convert the active scan lines from 1080 to 1035, without changing the aspect ratio.

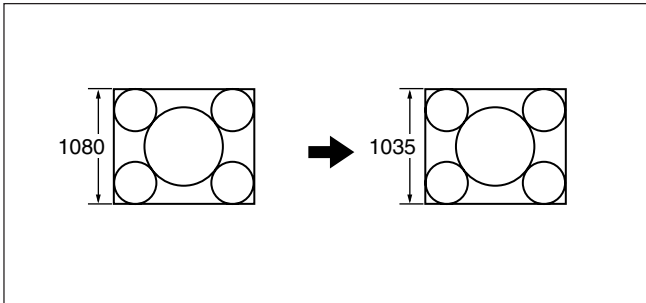

**1080 ⇒ 1035 (CROP):** Convert the active scan lines from 1080 to 1035. Crop the top, bottom, left, and right, then stretch the image horizontally.

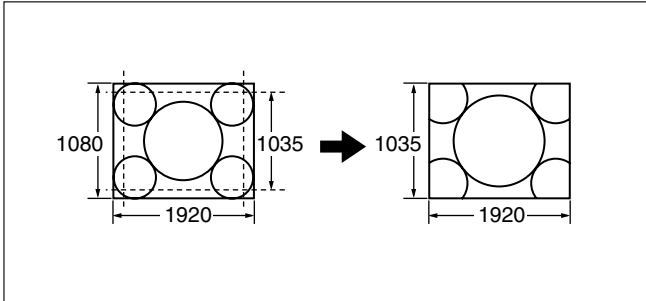

### When setup menu item 018 ACTIVE LINE SELECT is set to 1080

Select the conversion mode in setup menu item 917 ACTIVE LINE 1080 CONVERT MODE.

**1035 ⇒ 1080 (CONV):** Convert the active scan lines from 1035 to 1080, without changing the aspect ratio.

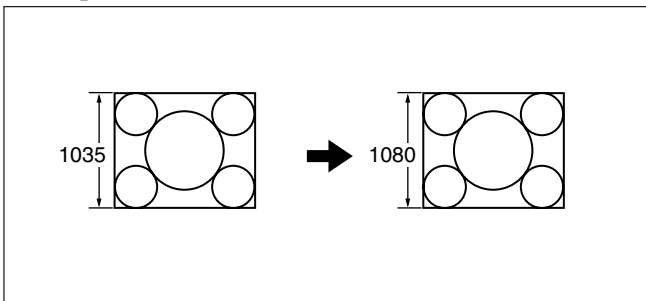

**1035 ⇒ 1080 (PANEL):** Convert the active scan lines from 1035 to 1080. Insert the 1035 lines into 1080 lines, then compress horizontally.

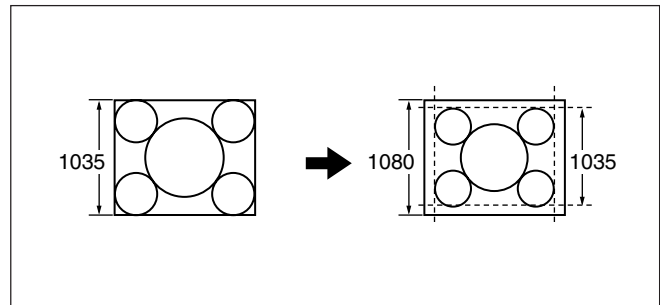

## Menu bank operations (menu items B01 to B13)

This unit allows menu settings to be saved in what are termed “menu banks”. Saved sets of menu settings can be recalled for use as required.

### To save the current active menu settings

Set one of menu items B11 SAVE BANK 1 to B13 SAVE BANK 3 to ON, depending on which of the menu banks you wish to save in, then press the F5 (SET) button.

## 9-2 Setup Menu Operations

### To recall settings from a menu bank

When recalling the settings saved in one of menu banks 1 to 3, set the corresponding one of menu items B01 RECALL BANK 1 to B03 RECALL BANK 3 to ON, then press F5 (SET) button.

When you wish to recall the settings saved in menu bank 4, select menu bank-4 with menu item B20 PRESET SETUP.

*For details about menu bank 4, refer to the Maintenance Manual.*

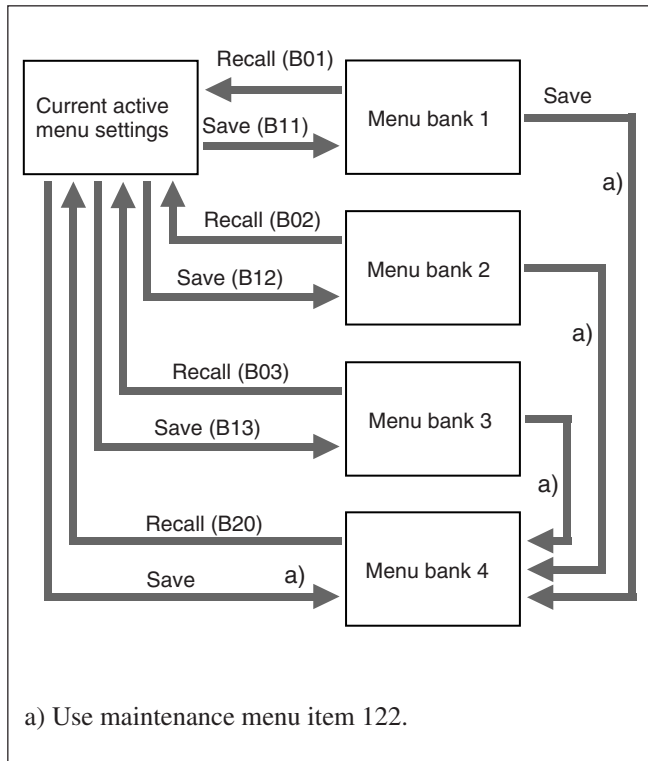

The current active setup menu settings as well as settings saved in menu banks are stored in separate storage areas for 59.94i, 29.97PsF, 23.98PsF and 50i, 25PsF, 24PsF modes.

## 9-3 Items in the Basic Setup Menu

The basic setup menu contains the following items.

In the “Settings” column of the table, the factory default settings are indicated by an enclosing box.

Item number	Item name	Settings
001	PREROLL TIME	<b>0S ...</b> <span style="border: 1px solid black;">5S</span> <b>... 30S</b> : Set the preroll time to between 0 and 30 seconds. A preroll time of at least 5 seconds is recommended when using this unit for editing.
002 <sup>a)</sup>	CHARACTER H-POSITION	Adjust the horizontal screen position of the character information output from the COMPOSITE VIDEO OUTPUT 3(SUPER) connector, HDSDI OUTPUT 3(SUPER) connector, and SDI OUTPUT 3(SUPER) connector for superimposed display on the monitor. <b>00 ...</b> <span style="border: 1px solid black;">1E</span> <b>... 3C (59.94i, 29.97PsF, 23.98PsF mode)</b> / <b>00 ...</b> <span style="border: 1px solid black;">1B</span> <b>... 36 (50i, 25PsF, 24PsF mode)</b> : The hexadecimal value 00 is for the far left of the screen and increasing the value moves the position of the characters to the right.
003 <sup>a), b)</sup>	CHARACTER V-POSITION	Adjust the vertical screen position of the first line of the character information output from the COMPOSITE VIDEO OUTPUT 3(SUPER) connector, HDSDI OUTPUT 3(SUPER) connector, and SDI OUTPUT 3(SUPER) connector for superimposed display on the monitor. <b>00 ...</b> <span style="border: 1px solid black;">57</span> <b>... 6C (59.94i, 29.97PsF, 23.98PsF mode)</b> / <b>00 ...</b> <span style="border: 1px solid black;">70</span> <b>... 88 (50i, 25PsF, 24PsF mode)</b> : The hexadecimal value 00 is for the top of the screen and increasing the value lowers the position of the characters.
005	DISPLAY INFORMATION SELECT	Determines the kind of character information to be output from the COMPOSITE VIDEO OUTPUT 3(SUPER) connector, HDSDI OUTPUT 3(SUPER) connector, and SDI OUTPUT 3(SUPER) connector when the function menu item CHARA is set to ON. <b>T&amp;STA</b> : Time data display information and the unit's status <b>T&amp;UB</b> : Time data display information and the user's bits <b>T&amp;CTL</b> : Time data display information and CTL <b>T&amp;T</b> : Time data display information and time code (LTC or VITC) <b>TIME</b> : Time code (LTC or VITC) only If there is an overlap between the setting of this item and the setting of the control panel, it is automatically avoided. For example, if CTL is selected on the control panel and this menu item setting is T&CTL, then CTL and LTC are output.
006	LOCAL FUNCTION ENABLE	Determines which buttons on the control panel are enabled when this unit is controlled from external equipment. <b>DIS</b> : All buttons and switches are disabled. <b>S&amp;E&amp;F</b> : Only the STOP button, EJECT button, and F1 to F6 buttons are enabled. <b>ENA</b> : All buttons and switches are enabled. <b>MAP</b> : Follow the LOCAL KEY MAP setting.  <i>For information about setting the LOCAL KEY MAP, see menu item 023 (LOCAL KEY MAP) (page 9-9).</i>
007	TAPE TIMER DISPLAY	Determines whether to display the CTL count in 12-hour mode or 24-hour mode. <b>+ -12H</b> : 12-hour mode <b>24H</b> : 24-hour mode

a) When setting items 002 and 003, watch the monitor screen, and adjust to the required state.

b) **Note**

When displaying time code values, there is a slight time delay. Therefore, when creating a tape for off-line editing, the information inserted in the upper half of the screen may be delayed by one frame.

(Continued)

## 9-3 Items in the Basic Setup Menu

Item number	Item name	Settings
009 <sup>a)</sup>	CHARACTER TYPE	<p>Determines the type of characters such as time code output from the COMPOSITE VIDEO OUTPUT 3(SUPER) connector, HDSDI OUTPUT 3(SUPER) connector, and SDI OUTPUT 3(SUPER) connector for superimposed display on the monitor.</p> <p><b>WHITE</b>: White letters on a black background  <b>BLACK</b>: Black letters on a white background  <b>W/OUT</b>: White letters with black outline  <b>B/OUT</b>: Black letters with white outline</p>
011 <sup>a)</sup>	CHARACTER V-SIZE	<p>Determines the vertical size of characters such as time code output from the COMPOSITE VIDEO OUTPUT 3(SUPER) connector, HDSDI OUTPUT 3(SUPER) connector, and SDI OUTPUT 3(SUPER) connector for superimposed display on the monitor.</p> <p><b>×1</b>: Standard size  <b>×2</b>: 2 times standard size</p>
013	SYSTEM FREQUENCY SELECT	<p>Specify whether to enable switching of the system frequency between 59.94i, 50i, 29.97PsF, 24PsF and 23.98PsF.</p> <p><b>OFF</b>: Disable switching.  <b>ON</b>: Enable switching.            When ON is selected, the menu display changes to allow switching of the setting between 59.94i, 50i, 29.97PsF, 25PsF, 24PsF, and 23.98PsF.</p> <p><i>For the procedure for switching the system frequency, see page 9-4.</i></p> <p><b>Notes</b></p> <ul style="list-style-type: none"> <li>• For the basic and extended setup menus, separate settings are saved for 59.94i, 29.97PsF, 23.98PsF and 50i, 25PsF, 24PsF modes. When you switch systems, all menu items change to the settings established in the new system. (These are different from the settings for the mode before switching.)</li> <li>• When the unit is used in 50i, 25PsF mode, analog tape can only be played back in the simple playback mode.</li> </ul>
018	ACTIVE LINE SELECT (Valid only in 59.94i or 29.97PsF mode.)	<p>Enable or disable switching of the number of active scan lines for HDSDI output (OFF TAPE/1035/1080/720P).</p> <p><b>OFF</b>: Disable switching.  <b>ON</b>: Enable switching.            When ON is selected, the menu display changes to allow switching of the setting between OFF TAPE, 1035, 1080, and 720P.</p> <p><i>For the procedure for switching the number of active scan lines, see page 9-4.</i></p>

a) When setting items 009 and 011, watch the monitor screen, and adjust to the required state.

(Continued)

Item number	Item name	Settings	
023	LOCAL KEY MAP	When MAP is selected in menu item 006, the buttons that can be operated on the control panel of this unit when it is being controlled by remote control from another device can be selected from the following sub-items. The settings of each sub-item are as follows. <b>DIS</b> : Do not function. <b>ENA</b> : Function.	
	Sub-item		
	1	STOP	Select whether the STOP button functions.
	2	PLAY	Select whether the PLAY button functions.
	3	STANDBY	Select whether the STANDBY button functions.
	4	EJECT	Select whether the EJECT button functions.
	5	JOG	Select whether the JOG button functions.
	6	SHUTTLE	Select whether the SHUTTLE button functions.
	7	VAR	Select whether the VAR button functions.
	8	FF/REW	Select whether the F FWD and REW buttons function.
	9	PREROLL	Select whether the PREROLL button functions.
	10	LEARN/CUE/PLAY	Select whether the LEARN and CUE/PLAY buttons function.
	11	F-KEY	Select whether the F1 to F6 buttons function.
	12	AUDIO/MONITOR	Select whether the audio monitor signal selection buttons function.
13	OTHERS	Select whether the ENTRY, STUNT IN, STUNT OUT, PLAY IN, PLAY OUT, TRIM+, TRIM-, GS-MARK, GS-LIST, DELETE, and DMC EDIT buttons function.	
B01	RECALL BANK 1	Set to ON to recall menu settings from menu bank 1.	
B02	RECALL BANK 2	Set to ON to recall menu settings from menu bank 2.	
B03	RECALL BANK 3	Set to ON to recall menu settings from menu bank 3.	
B11	SAVE BANK 1	Set to ON to save current active menu settings to menu bank 1.	
B12	SAVE BANK 2	Set to ON to save current active menu settings to menu bank 2.	
B13	SAVE BANK 3	Set to ON to save current active menu settings to menu bank 3.	
B20	RESET SETUP	Set to ON to reset current active menu settings to factory default values.	

# 9-4 Items in the Extended Setup Menu

The extended setup menu contains the following items.

In the “Settings” column of the table, the factory default settings are indicated by an enclosing box.

Menu items in the range 100 to 199, relating to the control panels

Item number	Item name	Settings
101	SELECTION FOR SEARCH DIAL ENABLE	Select how the unit enters the search mode. <b>DIAL</b> : Turning the search dial switches to search mode at all times except during editing. <b>KEY</b> : One of the JOG, SHUTTLE, and VAR buttons must be pressed to switch to search mode.
102	MAXIMUM SPEED	Select the fast forward and rewind tape speed and also search mode speed during tape playback. <b>MAX</b> : Perform fast forward, rewind, and search mode playback at the maximum speeds. <b>MX/24</b> : Perform fast forward and rewind at the maximum speeds, and search mode playback at up to 24 times normal speed. <b>MX/35</b> : Perform fast forward and rewind at the maximum speeds, and search mode playback at up to 35 times normal speed. <b>×24</b> : Perform fast forward and rewind at 24 times normal speed, and search mode playback at up to 24 times normal speed. <b>×35</b> : Perform fast forward and rewind at 35 times normal speed, and search mode playback at up to 35 times normal speed.  <b>Maximum fast forward and rewind speeds</b> HDCAM cassette: 50 times normal speed  <b>Maximum search mode speeds</b> HDCAM cassette: 50 times normal speed
103	AUDIO SELECTED LINE OUT	Select the output signal to the MONITOR OUTPUT connectors during playback of analog Betacam-format tape. <b>MANU</b> : Output the signals selected by the audio monitor signal selection buttons on the lower control panel. <b>AUTO1</b> : Output stereo, using the AFM channels (3 and 4) for playback from metal tape, and the LNG channels (1 and 2) for playback from oxide tape. <b>AUTO2</b> : Output the signals selected by the audio monitor signal selection buttons on the lower control panel, but during variable speed playback, if AFM is selected, automatically switch to LNG.
104	AUDIO MUTING TIME	Select the length of time for which audio muting occurs when the unit switches to playback either from stopped or from still playback in the search mode. <b>OFF</b> : Set the audio muting time to zero (i.e. no muting). <b>0.1S to 1.0S</b> : Set the audio muting time from 0.1 second to 1.0 second, in 0.1-second increments.
105	REFERENCE SYSTEM ALARM	Select whether or not to display a warning when the video/audio reference signal selected by the function menu item OUTREF, is not supplied or is out of phase with the input video signal. <b>OFF</b> : No warning. <b>ON</b> : Flash the STOP button as a warning.
106	CAPSTAN LOCK	Select the capstan servo lock mode. <b>PANEL</b> : The capstan servo lock mode is determined by the function menu item CAPSTN. <b>2F</b> : The capstan servo locks every two fields regardless of the setting of the function menu item CAPSTN. <b>4F</b> : The capstan servo locks every four fields regardless of the setting of the function menu item CAPSTN. <b>8F (For 50i, 25PsF mode only)</b> : The capstan servo locks every eight fields regardless of the setting of the function menu item CAPSTN.  <b>Note</b> The setting is 2F when operating in 24PsF or 23.98PsF mode, and this item is not displayed.

(Continued)



Menu items in the range 100 to 199, relating to the control panels (Continued)

Item number	Item name	Settings	
111	TSO PLAY	Select whether or not to enable tape speed override mode. <b>DIS</b> : Disable tape speed override mode. <b>TSO</b> : Enable tape speed override mode.	
116	JOG DIAL RESPONSE	Select the tape speed characteristics for the search dial rotation rate (VTR commands). <b>TYPE1</b> : Tape speed varies linearly over the range -1 to +1. <b>TYPE2</b> : Tape speed varies stepwise as shown in figure <sup>a)</sup> below over the range -3 to +3. (Characterized by a zone around -1 to +1 where the tape speed is independent of the search dial rotation rate. When playing back an HDCAM tape, however, tape speed characteristic TYPE 4 applies.) <b>TYPE3</b> : Tape speed varies linearly over the range -3 to +3, as shown in figure <sup>b)</sup> below. <b>TYPE4</b> : Tape speed varies stepwise as shown in figure <sup>c)</sup> below over the range -2 to +2. (Characterized by a zone around -1 to +1 where the tape speed is independent of the search dial rotation rate)	
117	CONTROL PANEL SELECTION	Select the control panel function when the PANEL SELECT switch on the switch panel is set to REAR. <b>SW</b> : Only the control panel connected to the CONTROL PANEL connector on the connector panel functions. <b>PARA</b> : The control panels connected to the CONTROL PANEL connectors on the switch panel and connector panel both function.	
118	KEY INHIBIT SWITCH EFFECTIVE AREA	Select which switches and buttons can be operated when the KEY INHI switch on the switch panel is set to ON. The following sub-items control different sets of switches and buttons independently.	
	Sub-item		
	1	REMOTE SELECT	Select whether the REMOTE 1(9P) and 2(50P) buttons in the upper control panel are enabled. <b>DIS</b> : Disabled <b>ENA</b> : Enabled
	2	AUDIO/F-KEY	Select whether the audio monitor signal selection buttons and F1 to F6 buttons in the lower control panel are enabled. <b>DIS</b> : Disabled <b>ENA</b> : Enabled <b>AUDIO</b> : The monitor signal selection do not function. <b>F-KEY</b> : The function key (including HOME) do not function.
3	MODE CONTROL	Select which switch and button operations can be carried out from the lower control panel of this unit or an external control panel connected to this unit. <b>DIS</b> : All switches and buttons are disabled. <b>EDIT</b> : All switches and buttons for editing operations other than the audio monitor signal selection buttons and F1 to F6 buttons are disabled. <b>ENA</b> : All switches and buttons other than the audio monitor signal selection buttons and F1 to F6 buttons are enabled.	

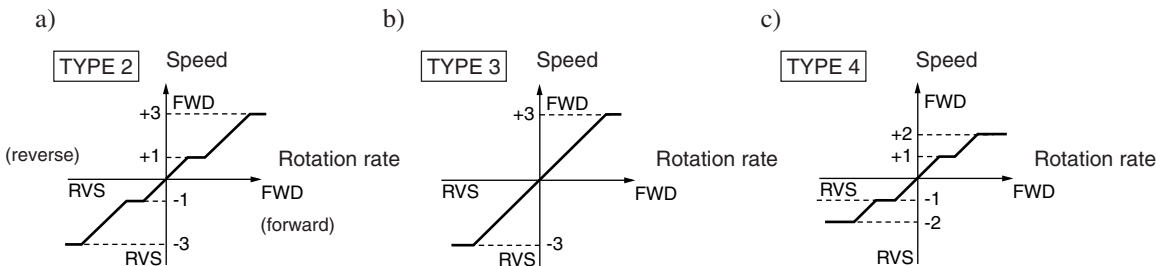

(Continued)

## 9-4 Items in the Extended Setup Menu

Menu items in the range 100 to 199, relating to the control panels (Continued)

Item number	Item name	Settings
119	VARIABLE SPEED LIMIT IN KEY PANEL CONTROL	Select the playback speed range when carrying out playback in variable speed mode from the control panel of this unit. <b>OFF</b> : -1 to +2 times normal speed <b>ON</b> : 0 to 1 times normal speed
120	CTL LOCK IN VAR/SHTL	Select whether the tape transport should be phase-locked to the CTL signal during playback in variable speed or shuttle mode. <b>OFF</b> : Not phase-locked. <b>ON</b> : Phase-locked at the following speeds: -1, -0.5, 0.5, 1.0 and 2.0 times normal.
121	DT MODE	Select field or frame mode for variable speed playback. <b>FIELD</b> : Always field playback <b>FRAME</b> : Frame playback in the noiseless playback speed range; otherwise field playback. Frame playback provides higher-density still pictures than field playback.  <b>Notes</b> <ul style="list-style-type: none"> <li>• For analog Betacam playback, field playback is always used. For Digital Betacam playback, the frame playback is valid only in the forward direction.</li> <li>• In the case of HDCAM tapes recorded in PsF mode, playback is automatically performed in frame mode.</li> </ul>
125	AUTO REWIND	Select whether to rewind the tape automatically when playback reaches the end of a tape. <b>DIS</b> : Do not rewind the tape automatically. <b>ENA</b> : Rewind the tape automatically.
130	TIMER DISPLAY DIMMER CONTROL	Set the brightness of the time data/menu display panel. <b>0 to 7</b> : Set in this range. 0 is the brightest, and 7 the dimmest.
133	TELE-FILE CONTROL MODE	Select the device used for data modification operations in the Tele-File menu. <b>CONTROL PANEL</b> : Operate with the control panel of this unit. <b>REMOTE</b> : Operate with remote devices connected to connectors such as REMOTE1, REMOTE2, and RS-232C.
134	TELE-FILE MENU AUTO POPUP	Select whether to open the Tele-File menu automatically when a cassette with a Tele-File label is loaded. However, this is valid only when the function menu is HOME, or page 1 to 6. <b>OFF</b> : Do not open the Tele-File menu automatically. <b>ON</b> : Open the Tele-File menu automatically.
135	TELE-FILE THREAD COUNTER CLEAR MODE	Select whether to clear the thread counter when formatting a Tele-File. <b>NOT CLEAR</b> : Do not clear the thread counter. <b>WHEN FORMAT</b> : Clear the thread counter.
136	TELE-FILE IN OUT INPUT CONTINUE	Select whether to continuously input log (IN and OUT point) data in the Tele-File menu screen. <b>OFF</b> : Do not continuously input log (IN and OUT point) data. <b>ON</b> : Continuously input log (IN and OUT point) data.
139	LOST LOCK DISPLAY ON CONTROL PANEL	Select whether or not to display a "LOST LOCK" indication on the control panel when the lock is lost. <b>OFF</b> : No display on control panel for LOST LOCK. <b>ON</b> : Display on control panel for LOST LOCK.

Menu items in the range 200 to 299, relating to the remote control interface

Item number	Item name	Settings
201	PARA RUN	<p>Select whether or not to use synchronized operation for two or more VTRs.  <b>DIS</b>: No synchronized operation  <b>ENA</b>: Use synchronized operation</p> <p><b>Note</b>                      To use synchronized operation for two or more VTRs, set item 201 to "ENA" on all of the VTRs.</p>
202	CF FLAG (Valid only in 50i or 25PsF mode.)	<p>Select the mode for locking to the color framing sent from the remote controller.  <b>8F</b>: Eight-field locking mode  <b>4F/8F</b>: Four- or eight-field locking mode</p>
211	REMOTE1 PORT	<p>Select how to use the REMOTE 1-IN(9P) and REMOTE 1-OUT(9P) connectors on the connector panel.  <b>I&amp;O</b>: Both the IN and OUT connectors are effective whether in local or remote mode.  <b>IN</b>: Only the IN connector is effective whether in local or remote mode.  <b>OUT</b>: Only the OUT connector is effective whether in local or remote mode.  <b>PANEL</b>: Allows you to select i&amp;o, in, or out using the function menu.</p> <p><b>Note</b>                      When selecting "PANEL", first define user-defined function key RMT1 in the HOME2 page.</p> <p><i>On how to define user-defined function keys in the HOME2 page, refer to the Maintenance Manual Volume 1.</i></p>
212	VIDEO REMOTE CONTROL SELECT (Invalid in 24PsF or 23.98PsF mode.)	<p>Make settings for control from HKDV-900/503 via the VIDEO CONTROL (15P) connector.</p>
	Sub-item	
	1	IMAGE ENHANCER
2	D2 SETUP	<p>Select the menu item to be controlled by the SETUP dial on the HKDV-900/503 with the D2 button pressed.  <b>setup</b>: Sub-item (OUTPUT LEVEL) of menu item 713 (VIDEO SETUP REFERENCE LEVEL)  <b>black</b>: Menu item 718 (SETUP LEVEL)</p> <p><i>For details, see the description of menu item 718.</i></p> <p><b>Note</b>                      After changing the setting for this item, power off this unit or HKDV-900/503 and power it on again.</p>

## 9-4 Items in the Extended Setup Menu

Menu items in the range 300 to 399, relating to editing operations

Item number	Item name	Settings
301	VAR SPEED RANGE FOR SYNCHRONIZATION	Select the playback speed range when carrying out playback in variable speed mode from a remote control unit connected to the REMOTE-1 IN(9P) connector or REMOTE-1 OUT (9P) connector. <b>-1~+2</b> : -1 to +2 times normal speed for HDCAM and Betacam SX tapes. -1 to +3 times normal speed for Digital Betacam, MPEG IMX, and analog tapes. <b>~2.45</b> : -1.5 to +2.45 times normal speed for HDCAM and Betacam SX tapes. -1.5 to +3.45 times normal speed for Digital Betacam, MPEG IMX, and analog tapes.
302	CAPSTAN RE-LOCKING DIRECTION (Invalid in 24PsF or 23.98PsF mode.)	<b>In 59.94i, 29.97PsF mode</b> When the function menu item CAPSTN is set to 4F, select whether the capstan servo should lock by accelerating or decelerating. <b>DECEL</b> : Lock by decelerating. <b>ACCEL</b> : Lock by accelerating. <b>In 50i, 25PsF mode</b> When the function menu item CAPSTN is set to 4F or 8F, select whether the capstan servo should lock by accelerating or decelerating. <b>DECEL</b> : Lock by decelerating. <b>ACCEL</b> : Lock by accelerating.
306	DMC INITIAL SPEED	Select the initial speed automatically set when carrying out DMC playback. <b>Note</b> If you want to carry out DMC playback after setting this menu item, first press the DMC EDIT and DELETE buttons simultaneously to turn off the DMC EDIT button. <b>MANU</b> : The speed determined by the rotation of the search dial <b>PLAY</b> : Normal playback speed <b>STILL</b> : Stationary <b>±0.03 to ±1, +2</b> : Speed set in the range ±0.03 to +2 (select from +2, ±1, ±0.5, ±0.2, ±0.1, ±0.03)
307	AUTO-DELETION FOR INCONSISTENT DATA	Select what happens when an erroneous edit point is set. <b>MANU</b> : A warning is given by flashing the DELETE button on the lower control panel. The operator must manually delete the unnecessary edit points or correct the erroneous edit point. <b>NEG&amp;E</b> : When inconsistent edit points are set, such as when an OUT point is before an IN point, or an audio OUT point is before an audio IN point, or when too many edit points are specified, the previously set edit point is deleted. <b>NEG</b> : When inconsistent edit points are set, such as when an OUT point is before an IN point, or an audio OUT point is before an audio IN point, the previously set edit point is deleted. When more edit points than necessary are specified, the DELETE button on the control panel flashes to give a warning. <b>Note</b> Pressing the button corresponding to an edit point to be deleted and the DELETE button simultaneously deletes the edit point. If an erroneous edit point is set (the DELETE button is flashing), editing is not executed.
320	DIGITAL AUDIO PB PROCESS ON EDIT POINT (Invalid in 24PsF or 23.98PsF mode.)	Select the treatment of audio playback at edit points. <b>CUT</b> : Carry out cut editing (possibly resulting in audio discontinuities at the edit point). <b>FADE</b> : Fade out and fade in.

(Continued)

Menu items in the range 300 to 399, relating to editing operations (Continued)

Item number	Item name	Settings
337	EXTERNAL REFERENCE SELECT	<p>Select the signal used when this unit is set up by setup menu item 309 and F2(OUTREF) in function menu page 4 to use an external reference video signal.</p> <p><b>HD</b>: Use a high definition reference video signal. Input a three-valued (positive and negative) sync signal to the REF.VIDEO INPUT connector.</p> <p><b>SD</b>: Use a reference video signal. Input a video signal with chroma burst (VBS) or a monochrome video signal (VS) to the REF.VIDEO INPUT connector.</p> <p><b>Note</b> The setting is HD when operating in 24PsF or 23.98PsF mode, and this item is not displayed.</p>
338	OUTPUT AUDIO/TC PHASE	<p>Set the audio (AES/EBU and analog) and time code output phase.</p> <p><b>HD</b>: Sync with HDSDI output phase.</p> <p><b>SD</b>: Sync with SD output phase.</p> <p><b>Note</b> The setting is HD when operating in 24PsF or 23.98PsF mode, and this item is not displayed.</p>

Menu items in the range 400 to 499, relating to preroll

Item number	Item name	Settings
401	FUNCTION MODE AFTER CUEUP	<p>Select the state that the unit goes into after a cuing-up operation.</p> <p><b>STOP</b>: Stop (the “stop mode”)</p> <p><b>STILL</b>: Still playback (in search mode)</p> <p><b>Note</b> When controlling this unit from an editor with the standard constants set, select “STOP”.</p>
402	TIME REFERENCE FOR PREROLL	<p>When prerolling a tape with time code discontinuities, select whether or not to use CTL pulses to count time code from before a discontinuity.</p> <p><b>CTL</b>: Use CTL pulses to count time code.</p> <p><b>TC</b>: Do not use CTL pulses to count time code.</p>
403	AUTOMATIC PREROLL REFERENCE ENTRY	<p>Select whether or not the edit IN point is automatically set by pressing the PREROLL button, when the IN point is not set before starting preroll.</p> <p><b>DIS</b>: IN point is not set automatically.</p> <p><b>ENA</b>: IN point is set automatically.</p>
405	CUEUP BY CTL	<p>Select the tape transport mode when cuing. This setting is valid only when the function menu item CTL/TC is set to CTL.</p> <p><b>CAP.</b>: During cuing up, the tape transport is in the “pinch ON” state (maximum tape speed 10 times normal).</p> <p><b>REEL</b>: During cuing up, the tape transport is in the “pinch OFF” state. As the tape approaches the cue up point and the tape speed drops, the tape transport switches to the “pinch ON” state.<sup>a)</sup></p> <p>To give priority to editing accuracy, select “CAP”.</p>

a) When controlled from an editor (BVE-2000/9100 etc.), selecting “REEL” allows high-speed cuing up.

## 9-4 Items in the Extended Setup Menu

Menu items in the range 500 to 599, relating to tape protection

Item number	Item name	Settings
501	STILL TIMER	Select the time delay from the tape transport stopping (either the "stop mode" or the still playback mode in search mode) until the unit automatically switches to the tape protection mode, in order to protect the video heads and the tape. <b>0.5S to [8M] to 30M:</b> Set the value in the range 0.5 seconds to 30 minutes.
502	TAPE PROTECTION MODE FROM SEARCH	Select the operation of the protection mode to protect the video heads and tape when in the still playback mode in search mode (jog/shuttle). <b>[STEP]:</b> Step forward at $\frac{1}{30}$ normal speed every 2 seconds. <b>[STDBY]:</b> Switch to "Standby OFF mode" (the unit not on standby). <b>[T.REL]:</b> Switch to tension release mode (the tape tension slackened).
503	TAPE PROTECTION MODE FROM STOP	Select the operation of the protection mode to protect the video heads and tape when stopped (the "stop mode"). <b>[STDBY]:</b> Switch to "Standby OFF mode" (the unit not on standby). <b>[T.REL]:</b> Switch to tension release mode (the tape tension slackened). <b>[STEP]:</b> Step forward at $\frac{1}{30}$ normal speed every 2 seconds.
504	DRUM ROTATION IN STANDBY OFF	Select whether the drum rotates in "Standby OFF mode". <b>[OFF]:</b> Drum does not rotate. <b>[ON]:</b> Drum rotates.
505	STILL TENSION	Select the tape tension state in the still playback mode. <b>[NORML]:</b> Normal tape tension is maintained during still playback mode, ready for playback. <b>[LOOSE]:</b> Reduce the tape tension further from the NORML setting. (Select "LOOSE" when the unit is on standby for a long period of still playback, for example, in a library management system (LMS).)  <b>Note</b> When LOOSE is selected and the tape tension is reduced, playback cannot be guaranteed.

Menu items in the range 600 to 650, relating to the time code generator

Item number	Item name	Settings
601	VITC POSITION SEL-1 (Invalid in 24PsF or 23.98PsF mode.)	<b>In 59.94i, 29.97PsF mode</b> Select a line to insert the VITC in. (For SD output) <b>12H to [16H] to 20H:</b> Select any line from 12 to 20.  <b>Note</b> You can insert the VITC signal in two places. To insert it in two places, set both items 601 and 602.  <b>In 50i, 25PsF mode</b> Select a line to insert the VITC in. (For SD output) <b>9H to [19H] to 22H:</b> Select any line from 9 to 22.  <b>Note</b> You can insert the VITC signal in two places. To insert it in two places, set both items 601 and 602.

(Continued)

Menu items in the range 600 to 650, relating to the time code generator (Continued)

Item number	Item name	Settings
602	VITC POSITION SEL-2 (Invalid in 24PsF or 23.98PsF mode.)	<p><b>In 59.94i, 29.97PsF mode</b> Select a line to insert the VITC in. (For SD output) <b>12H to 18H to 20H:</b> Select any line from 12 to 20.</p> <p><b>Note</b> You can insert the VITC signal in two places. To insert it in two places, set both items 601 and 602.</p>
		<p><b>In 50i, 25PsF mode</b> Select a line to insert the VITC in. (For SD output) <b>9H to 21H to 22H:</b> Select any line from 9 to 22.</p> <p><b>Note</b> You can insert the VITC signal in two places. To insert it in two places, set both items 601 and 602.</p>
606	TC OUTPUT SIGNAL IN REGEN MODE	<p>Select the signal output from the TIME CODE OUT connector during normal (1) speed playback: <b>TAPE:</b> During tape playback, the playback time code signal is output without regeneration. <b>REGEN :</b> The playback time code is output after regeneration.</p>
617	LTC OUTPUT PHASE	<p>Set the output phase of time code signals (LTC). <b>TCG/R:</b> Output the playback time code signal during playback. When the edit preset function is on, output the time code signal generated by the internal time code generator. <b>INPUT:</b> Use the same phase as the input video. <b>OUTPT:</b> Use the same phase as the output video. <b>AUTO:</b> Use the same phase as the input video when editing, and use the same phase as the output video at other times (playback, etc.)</p>
618	UPCONV EMBEDDED VITC (Invalid in 24PsF or 23.98PsF mode.)	<p>Select the source time code for HD-SDI embedded VITC which is output after subjected to up-conversion during playback of SD-format tape. when <b>VITC:</b> Select VITC recorded on SD-format tape. <b>LTC :</b> Select LTC recorded on SD-format tape.</p>
620	TC CONVERT 24F -> 25F (In 50i or 25PsF mode only. Not displayed when operating in 720P-line mode.)	<p>Select whether to convert playback time code to 25F time code during playback of tape recorded in 24PsF or 23.98PsF mode. <b>OFF:</b> Do not convert time code. <b>ON:</b> Convert time code.</p>
	TC CONVERT 25F -> 24F (In 24PsF or 23.98PsF mode only. Not displayed when operating in 720P-line mode.)	<p>Select whether to convert playback time code to 24F time code during playback of tape recorded in 50i or 25PsF mode. <b>OFF:</b> Do not convert time code. <b>ON:</b> Convert time code.</p>

(Continued)



## 9-4 Items in the Extended Setup Menu

Menu items in the range 600 to 650, relating to the time code generator (Continued)

Item number	Item name	Settings
621	24F STARTING TC SEL (In 50i or 25PsF mode only. Not displayed when operating in 720P-line mode.)	Select one of the following settings for time code conversion from 24F to 25F. <b>OFF</b> : Do not set the starting TC <b>ON</b> : Set the starting TC  <b>To set the 24F starting TC</b> Press the F5 (SET) button with this menu item displayed in the menu display, to enter the starting TC setting mode. You can then set the user starting TC digit by digit using the F1 (PREV) button and F2 (NEXT) buttons for digit selection. When all required digits have been set correctly, press the F5 (SET) button again to save the starting TC and exit from the ID code setting mode.
	25F STARTING TC SEL (In 24PsF or 23.98PsF mode only. Not displayed when operating in 720P-line mode.)	Select one of the following settings for time code conversion from 25F to 24F. <b>OFF</b> : Do not set the starting TC <b>ON</b> : Set the starting TC  <b>To set the 25F starting TC</b> Press the F5 (SET) button with this menu item displayed in the menu display, to enter the starting TC setting mode. You can then set the user starting TC digit by digit using the F1 (PREV) button and F2 (NEXT) buttons for digit selection. When all required digits have been set correctly, press the F5 (SET) button again to save the starting TC and exit from the ID code setting mode.
622	24F JUMPING TC SEL (In 50i or 25PsF mode only. Not displayed when operating in 720P-line mode.)	Select one of the following settings for time code conversion from 24F to 25F. <b>-3H</b> : Set JUMPING TC to "STARTING TC -3H". <b>-2H</b> : Set JUMPING TC to "STARTING TC -2H". <b>-1H</b> : Set JUMPING TC to "STARTING TC -1H". <b>+1H</b> : Set JUMPING TC to "STARTING TC +1H". <b>+2H</b> : Set JUMPING TC to "STARTING TC +2H". <b>+3H</b> : Set JUMPING TC to "STARTING TC +3H". <b>0H</b> : Set JUMPING TC to "STARTING TC".
	25F JUMPING TC SEL (In 24PsF or 23.98PsF mode only. Not displayed when operating in 720P-line mode.)	Select one of the following settings for time code conversion from 25F to 24F. <b>-3H</b> : Set JUMPING TC to "STARTING TC -3H". <b>-2H</b> : Set JUMPING TC to "STARTING TC -2H". <b>-1H</b> : Set JUMPING TC to "STARTING TC -1H". <b>+1H</b> : Set JUMPING TC to "STARTING TC +1H". <b>+2H</b> : Set JUMPING TC to "STARTING TC +2H". <b>+3H</b> : Set JUMPING TC to "STARTING TC +3H". <b>0H</b> : Set JUMPING TC to "STARTING TC".

Menu items in the range 651 to 699, relating to the UMID

Item number	Item name	Settings
651	UMID OUTPUT	Select UMID output and the UMID type. <b>off</b> : Do not output UMID. <b>BASIC</b> : Output Basic UMID. <b>EXTND</b> : Output Extended UMID.  <b>Notes</b> <ul style="list-style-type: none"> <li>• Even if EXTND is selected, Basic UMID is output if Basic UMID is recorded on the tape being played back.</li> <li>• When operating in 720P active scan line mode, UMID is not output.</li> </ul>



Menu items in the range 700 to 799, relating to video control

Item number	Item name		Settings
703	BLANK LINE SELECT (Invalid in 24PsF or 23.98PsF mode.)		Switch blanking on or off for individual lines in the vertical blanking interval of the SD video signal. The Y/C signal and odd/even fields are blanked simultaneously.
	Sub-item		
	0	ALL LINE	<b>[---]</b> : Specify the blanking for each line separately. <b>BLANK</b> : Regardless of the setting of other sub-items, blank all lines which can be specified in this menu item. <b>THROU</b> : Regardless of the setting of other sub-items, switch off blanking for all lines which can be specified in this menu item.
In 59.94i, 29.97PsF mode	12 ... 19	LINE 12 ... LINE 19	Specify blanking for lines 12 to 19. <b>BLANK</b> : Carry out blanking. <b>THROU</b> : Switch off blanking.
	20	LINE 20	Specify blanking for line 20. <b>BLANK</b> : Carry out blanking. <b>HALF</b> : Carry out half-blanking. <b>THROU</b> : Switch off blanking.
In 50i, 25PsF mode	9 ... 22	LINE 9 ... LINE 22	Specify blanking for lines 9 to 22. <b>BLANK</b> : Carry out blanking. <b>THROU</b> : Switch off blanking.
	23	LINE 23	Specify blanking for line 23. <b>HALF</b> : Carry out half-blanking. <b>THROU</b> : Switch off blanking.
705	EDGE SUBCARRIER REDUCER MODE (Invalid in 24PsF or 23.98PsF mode.)		During playback of a composite signal, in the playback circuit the edge subcarrier reducer (ESR) is automatically switched on or off according to the VTR operation. When recording a "Non-Standard" signal, for example, if the color edges are not as good as with a proper signal, the ESR can be forced on. This item makes this selection. <b>AUTO</b> : ESR is switched on and off automatically. <b>ON</b> : ESR operation is forced on.
707	FORCED VERTICAL INTERPOLATION OFF		The "Y-add" <sup>a)</sup> function is normally switched on automatically during jog or variable speed playback. This item selects whether or not to force the "Y-add" function off. <b>AUTO</b> : Automatically switch the "Y-add" function on. <b>OFF</b> : Force the "Y-add" function off.

a) The "Y-add" function is a circuit operation to interpolate the video signal vertically during jog or variable speed playback for the purpose of reducing the vertical movement of the playback picture.

(Continued)

## 9-4 Items in the Extended Setup Menu

Menu items in the range 700 to 799, relating to video control (Continued)

Item number	Item name	Settings															
709	CAV LEVEL FORMAT (Valid only in 59.94i or 29.97PsF mode.)	Select whether the analog component output should be D-1 or Betacam. <table border="1"> <thead> <tr> <th>Format</th> <th>Color bars</th> <th>Y video</th> <th>Y sync</th> <th>R-Y/B-Y</th> </tr> </thead> <tbody> <tr> <td>D-1 CAV</td> <td>100/0/100/0</td> <td>700 mV</td> <td>300 mV</td> <td>700 mV</td> </tr> <tr> <td>Betacam</td> <td>100/7.5/77/7.5</td> <td>714 mV</td> <td>286 mV</td> <td>700 mV</td> </tr> </tbody> </table>	Format	Color bars	Y video	Y sync	R-Y/B-Y	D-1 CAV	100/0/100/0	700 mV	300 mV	700 mV	Betacam	100/7.5/77/7.5	714 mV	286 mV	700 mV
	Format	Color bars	Y video	Y sync	R-Y/B-Y												
	D-1 CAV	100/0/100/0	700 mV	300 mV	700 mV												
Betacam	100/7.5/77/7.5	714 mV	286 mV	700 mV													
Sub-item																	
0	OUTPUT CAV LEVEL	Select the analog component output format. <b>[B-CAM]</b> : Betacam <b>D1</b> : D-1															
710	INTERNAL VIDEO SIGNAL GENERATOR	Select the test signal to be output from the VTR's internal test signal generator. <b>[OFF]</b> : No test signal is generated. <b>CB</b> : Color bar signal <b>MLTBS</b> : Multi-burst signal <b>10STP</b> : 10-step signal <b>PLSBR</b> : Pulse and bar signal <b>RAMP</b> : Ramp signal <b>BLACK</b> : Black signal															
712	VIDEO PROCESS ON CAP LOCK 2FIELD (Invalid in 24PsF or 23.98PsF mode.)	When the function menu item CAPSTN or setup menu item 106 is set to 2F for 2-field playback, select whether or not to carry out a "picture shift". <b>[OFF]</b> : No picture shift <b>ON</b> : Carry out picture shift.  <b>Note</b> To eliminate the adverse effect of the residual chrominance subcarrier component in the Y signal that is the result of the Y/C separation, this unit automatically applies a shift to the playback image in the H direction, so that even in 2-field playback a satisfactory image can be obtained.															
713	VIDEO SETUP REFERENCE LEVEL (Valid only in 59.94i, 29.97PsF mode.)	Set the video setup amounts to be removed from a Betacam playback signal and to be added to a composite output signal. There are independent settings for a Betacam signal and a composite output signal (referred to below as the output signal).  <b>Note</b> The setup amounts specified in this menu item have no connection with the function menu item SETUP/BLACK.															
	Sub-item																
	0	MASTER LEVEL	When the Betacam playback signal and output signal settings are "MSTER" (master), the setup amount specified for this sub-item is removed from the Betacam playback signal and is added to the output signal. <b>0.0% to [7.5%] to 10.0%</b> : Setting in this range, in 0.5% increments.														
	1	BETACAM PB LEVEL	<b>[MSTER]</b> : Set the Betacam playback signal to the master setting. <b>0.0% to 7.5% to 10.0%</b> : Set the setup amount to be removed from the Betacam playback signal in this range, in 0.5% increments.														
2	OUTPUT LEVEL	<b>[MSTER]</b> : Set the output signal to the master setting. <b>0.0% to 7.5% to 10.0%</b> : Set the setup amount to be added to the output signal in this range, in 0.5% increments.															

(Continued)

Menu items in the range 700 to 799, relating to video control (Continued)  
 (Items 715 to 720: Settings for controlling the SD video processing system according to the menu settings.)

Item number	Item name	Settings
715	VIDEO GAIN CONTROL	Adjust the video output level. 0 to <b>800H</b> to <b>B50H</b>  <b>Note</b> This item is valid for both HD and SD outputs.
716	CHROMA GAIN CONTROL	Adjust the chroma output level. 0 to <b>800H</b> to <b>B50H</b>  <b>Note</b> This item is valid for both HD and SD outputs.
717	CHROMA PHASE CONTROL	Adjust the SD chroma phase. 0 to <b>80H</b> to <b>FFH</b>  <b>Note</b> This item is valid for both HD and SD outputs.
718	SETUP LEVEL (59.94i, 29.97PsF mode)/BLACK LEVEL (50i, 25PsF mode) (Invalid in 24PsF or 23.98PsF mode.)	Adjust the SD setup level (black level). 0 to <b>110H</b> to <b>220H</b>  <b>Note</b> This item is valid for both HD and SD outputs when sub-item (D2 SETUP) of menu item 212 (VIDEO REMOTE CONTROL SELECT) is set to "black".
719	SYSTEM PHASE SYNC (Invalid in 24PsF or 23.98PsF mode.)	Adjust the SD output signal sync phase. 0 to <b>80H</b> to <b>FFH</b>
720	SYSTEM PHASE SC (Invalid in 24PsF or 23.98PsF mode.)	Adjust the SD output signal subcarrier phase. <b>0</b> to <b>3FFH</b>
721	Y/C DELAY (Invalid in 24PsF or 23.98PsF mode.)	For playback from an analog Betacam cassette, adjust the Y/C delay. 0 to <b>800H</b> to <b>FFFH</b>

(Continued)

**Notes**

- When you make settings for menu items 715 to 718 or 740 to 747, set the function menu item V.PROC to MENU. When it is set to MENU, all controls for video output processing on the control panel are disabled.
- When menu item 337 is set to SD, changing the settings of menu items 719 and 720 changes the phase of HD output signals as well as that of SD. After changing the settings, use the F1 (SYNC) and F2 (SC) items or menu items 745 and 746 on function menu page 3 to readjust the phase of HD output signals.

## 9-4 Items in the Extended Setup Menu

Menu items in the range 700 to 799, relating to video control (Continued)

Item number	Item name	Settings
726	H BLANKING WIDTH (Invalid in 24PsF or 23.98PsF mode.)	Select the horizontal blanking width of the video output signal. <b>NARROW</b> : Digital blanking (narrow) <b>WIDE</b> : Analog blanking (wide) When WIDE is selected, the horizontal blanking width complies with RS170A, and normally the blanking is widened and the image becomes narrower. It is recommended to select NARROW at the editing stage, then later, for broadcast transmission to select WIDE, to output a signal conforming to the standard.
728	OUTPUT SCH PHASE (Invalid in 24PsF or 23.98PsF mode.)	Set the subcarrier H phase. <b>0 to 800H to FFFH</b>
732	COMPOSITE MODE (Invalid in 24PsF or 23.98PsF mode.)	Select the chroma filter through which the composite video output signals pass. <b>WIDE</b> : Output via SMPTE wide <b>STD</b> : Output via SMPTE standard (narrow)
740	MASTER LEVEL (HD)	Adjust the high-definition video signal output from the HDSDI OUTPUT connector. This adjusts the Y, P <sub>B</sub> , and P <sub>R</sub> levels simultaneously. <b>0.0% (0H) to 100% (800H) to 141.3% (B4EH)</b>
741	Y LEVEL (HD)	Adjust the Y level of the high-definition video signal output from the HDSDI OUTPUT connector. <b>0.0% (0H) to 100% (800H) to 141.3% (B4EH)</b>
742	P <sub>B</sub> LEVEL (HD)	Adjust the P <sub>B</sub> level of the high-definition video signal output from the HDSDI OUTPUT connector. <b>0.0% (0H) to 100% (800H) to 141.3% (B4EH)</b>
743	P <sub>R</sub> LEVEL (HD)	Adjust the P <sub>R</sub> level of the high-definition video signal output from the HDSDI OUTPUT connector. <b>0.0% (0H) to 100% (800H) to 141.3% (B4EH)</b>
745	SETUP LEVEL (HD)	Adjust the setup level (59.94i, 29.97PsF mode)/black level (50i, 25PsF mode) of the high-definition video signal output from the HDSDI OUTPUT connector. <b>0 to 110H to 220H</b>
746	SYNC PHASE (HD)	Control the H sync phase of the high-definition video signal output from the HDSDI OUTPUT connector according to the menu. <b>0 to 80H to FFH</b>
747	FINE (HD)	Fine control the H sync phase of the high-definition video signal output from the HDSDI OUTPUT connector according to the menu. <b>0 to 3FFH</b>

Menu items in the range 800 to 899, relating to audio control

Item number	Item name	Settings
801	DIGITAL JOG SOUND	Turns the digital jog sound on and off. <b>OFF</b> : Digital jog sound is turned off. Audio of digital channels not subjected to speed correction is output. When the tape stops, after one second the audio is muted. <b>ON</b> : Digital jog sound is turned on. When the tape speed is in the range $\times-1$ to $\times+1$ (for Betacam SX playback, in the range $\times-1$ to $\times+2$ ), speed correction is carried out, and the same jog sound as a conventional analog VTR is output.
802	DIGITAL AUDIO MUTING IN SHUTTLE MODE	Set the digital audio muting conditions during shuttle playback. <b>OFF</b> : Not muted. <b>CUEUP</b> : Muted during cue-up or preroll operations. <b>FULL</b> : Muted in shuttle mode.
805	AUDIO MONITOR OUTPUT MIXING	Select the audio mixing method used for digital audio signals and Betacam playback analog audio signals supplied to the MONITOR OUTPUT connector. <b>ADD</b> : Simple addition <b>RMS</b> : Root-mean-square <b>AVE</b> : Simple average
806	LEVEL METER SCALE	Select the mode in which digital audio levels are displayed. <b>PEAK0</b> : Displays the audio level as negative values with the maximum level set to 0 dB. <b>REF.0</b> : Displays the audio level as positive and negative values with the reference level set to 0 dB.
807	AUDIO OUTPUT PHASE	Select the output timing of digital audio playback signals (HDSDI, SDI, and AES/EBU only). The reference position corresponds to a setting of 80H; when the setting is less than 80H, the output timing is advanced, and when it is higher than 80H, the output timing is delayed. (at 80H, 128 samples = approx. 2.7 ms, and 1 sample=approx. 20 $\mu$ s) <b>0 to 80 to FF</b> : Setting in this range
808	INTERNAL AUDIO SIGNAL GENERATOR	Select the operation of the internal audio test signal generator. <b>OFF</b> : No operation <b>SILNC</b> : Silent signal <b>1KHZ</b> : At 1 kHz, -20 dB FS sine wave is supplied to all audio input channels.
809	AUDIO LEVEL METER DIMMER CONTROL	Set the brightness of the audio level meters. <b>0 to 7</b> : Set in this range. 0 is the brightest, and 7 the dimmest.
823	NON-AUDIO FLAG PB (Invalid in 24PsF or 23.98PsF mode.)	Controls the non-audio flag when the playback format is Digital Betacam or Betacam SX.
	Sub-item	
	1 2	CH1/CH2 CH3/CH4

(Continued)

## 9-4 Items in the Extended Setup Menu

Menu items in the range 800 to 899, relating to audio control (Continued)

Item number	Item name	Settings
824	ANALOG LINE OUTPUT SELECT	Select the analog audio signals (tracks 1 to 8) to be assigned to audio output channels 1 to 4.
	Sub-item	
	1 CH1/CH2	<b>tr1/2</b> : Tracks 1 and 2 assigned to audio output channels 1 and 2 <b>tr3/4</b> : Tracks 3 and 4 assigned to audio output channels 1 and 2 <b>tr5/6</b> : Tracks 5 and 6 assigned to audio output channels 1 and 2 <b>tr7/8</b> : Tracks 7 and 8 assigned to audio output channels 1 and 2
2	CH3/CH4	<b>tr1/2</b> : Tracks 1 and 2 assigned to audio output channels 3 and 4 <b>tr3/4</b> : Tracks 3 and 4 assigned to audio output channels 3 and 4 <b>tr5/6</b> : Tracks 5 and 6 assigned to audio output channels 3 and 4 <b>tr7/8</b> : Tracks 7 and 8 assigned to audio output channels 3 and 4
825	AUDIO ADVANCE MODE	Set the audio output phase. <b>[OFF]</b> : Same as the video output phase <b>ON</b> : One frame ahead of the video output phase
826	AUDIO PB VOLUME SELECT	Selects which PB control knobs are assigned to control playback of digital audio channels. The settings for CH5 to CH8 are valid only for the HDW-M2100.
	Sub-item	
	0 ALL CH	<b>[DEFAULT]</b> : Use the following settings. <b>CH1</b> : Control knob 1 <b>CH2</b> : Control knob 2 <b>CH3</b> : Control knob 3 <b>CH4</b> : Control knob 4 <b>CH5</b> : Unity <b>CH6</b> : Unity <b>CH7</b> : Unity <b>CH8</b> : Unity <b>UNITY</b> : Set all channels to unity, and disable the control knobs. <b>MENU</b> : Use the following menu settings.
	1 CH1	<b>UNITY</b> : Set playback level to unity.
	2 CH2	<b>vol 1</b> : Assign playback level control to control knob 1.
	3 CH3	<b>vol 2</b> : Assign playback level control to control knob 2
	4 CH4	<b>vol 3</b> : Assign playback level control to control knob 3.
	5 CH5	<b>vol 4</b> : Assign playback level control to control knob 4.
	6 CH6	
	7 CH7	
8 CH8		

Menu items in the range 900 to 999, relating to digital processing

Item number	Item name	Settings
901	VIDEO OUTPUT DATA (Invalid in 24PsF or 23.98PsF mode.)	Set the bit length for SD video output data. <b>8bit</b> : Set the bit length to 8 bits. <b>10bit</b> : Set the bit length to 10 bits. It is recommended that you select the optimal setting for the device to which you are going to connect this unit.

(Continued)

Menu items in the range 900 to 999, relating to digital processing (Continued)

Item number	Item name	Settings
903	FREEZE MODE	<p>Select the freeze mode and timing.</p> <p><b>FIELD</b>: Freeze a video field. Field may be odd or even, according to the timing.</p> <p><b>FLD1</b>: Freeze an odd field.</p> <p><b>FLD2</b>: Freeze an even field.</p> <p><b>FRM12</b>: Freeze a frame consisting of an odd field and following even field.</p> <p><b>FRM21</b>: Freeze a frame consisting of an even field and following odd field.</p> <p>Odd and even fields are distinguished by the reference video signal.</p> <p>Changing the menu setting during a freeze does not affect the freeze image.</p> <p>The setting is reflected the next time a freeze is carried out.</p> <p>You can freeze an image using the DELETE button and TRIM+ button.</p> <p><i>For details, see menu item 904.</i></p>
904	FREEZE CONTROL FROM KEY PANEL	<p>Determine how the buttons used to freeze an image function.</p> <p><b>MOMNT</b>: Holding the DELETE button and pressing the TRIM+ button carries out a freeze. The freeze ends when the buttons are released.</p> <p><b>LATCH</b>: Holding the DELETE button and pressing the TRIM+ button carries out a freeze. The freeze continues even after the buttons are released.</p> <ul style="list-style-type: none"> <li>To update the freeze image Hold the DELETE button and press the TRIM+ button again.</li> <li>To end the freeze Hold the DELETE button and press the TRIM- button.</li> </ul>
905	AUTO FREEZE CONTROL	<p>Set the auto freeze function operation (conditions for ending a freeze, etc.).</p> <p>In dynamic tracking playback (so-called variable speed, jog, shuttle, or normal play), if there is a sudden worsening of the channel condition (entry into unrecorded area), this function freezes the image.</p> <p><b>DIS</b>: Disable the auto freeze function.</p> <p><b>MODE1</b>: End the freeze when signals which can be played back normally are restored.</p> <p><b>MODE2</b>: End freeze automatically on playback after stopping.</p> <ul style="list-style-type: none"> <li>The automatic freeze mode is determined by menu item 903.</li> <li>The freeze is ended immediately, regardless of the above conditions, when this unit is switched to any of the following modes: EDIT preset on Cue up</li> </ul>
906	STOP FREEZE CONTROL	<p>Select whether or not the STOP FREEZE function should operate.</p> <p><b>DIS</b>: Does not operate.</p> <p><b>ENA</b>: Operates.</p> <p><b>stby</b>: Operates only in the standby mode.</p>
916	ACTIVE LINE 1035 CONVERT MODE (Valid only in 59.94i or 29.97PsF mode.)	<p>Select the conversion mode for the number of active scan lines.</p> <p><b>conv</b>: Convert the active scan lines from 1080 to 1035, without changing the aspect ratio.</p> <p><b>crop</b>: Convert the active scan lines from 1080 to 1035. Crop the top, bottom, left, and right, then stretch the image horizontally.</p> <p><b>Note</b> This item is valid only when menu item 018 is set to 1035.</p>
917	ACTIVE LINE 1080 CONVERT MODE (Valid only in 59.94i or 29.97PsF mode.)	<p>Select the conversion mode for the number of active scan lines.</p> <p><b>conv</b>: Convert the active scan lines from 1035 to 1080, without changing the aspect ratio.</p> <p><b>panel</b>: Convert the active scan lines from 1035 to 1080. Insert the 1035 lines into 1080 lines, then compress horizontally.</p> <p><b>Note</b> This item is valid only when menu item 018 is set to 1080.</p>

(Continued)



## 9-4 Items in the Extended Setup Menu

Menu items in the range 900 to 999, relating to digital processing (Continued)

Item number	Item name	Settings
918	SLOW PROCESS MODE	Switch the filter for increasing the vertical resolution during slow-motion playback on or off. <b>ON:</b> Increase the vertical resolution in slow-motion playback. <b>OFF:</b> Do not increase the vertical resolution in slow-motion playback.  <b>Note</b> In the case of HDCAM tapes recorded in PsF mode, this item is invalid.
920	SD-SDI H-ANC CONTROL (Invalid in 24PsF or 23.98PsF mode.)	Select whether or not to add information to the SD output.
	Sub-item	
	1 AUDIO 5CH-8CH	<b>ON:</b> Add digital audio data channels 5 to 8. <b>OFF:</b> Do not add digital audio data channels 5 to 8.
	2 RP188 ATC	<b>ON:</b> Add RP188 time code data. <b>OFF:</b> Do not add RP188 time code data.
930	DOWN CONVERTER MODE (Invalid in 24PsF or 23.98PsF mode.)	Select the down-converter mode. <b>crop:</b> Select the edge-crop mode. <b>l-box:</b> Select the letter box mode. <b>squez:</b> Select the squeeze mode.
931	DOWN CONVERTER LETTER BOX MODE (Invalid in 24PsF or 23.98PsF mode.)	Select the aspect ratio of the down-converter output when menu item 930 is set to l-box. <b>16:9:</b> Set the aspect ratio of the HD-SD converter output to 16:9. <b>14:9:</b> Set the aspect ratio of the HD-SD converter output to 14:9. <b>13:9:</b> Set the aspect ratio of the HD-SD converter output to 13:9.
932	H CROP POSITION (DC) (Invalid in 24PsF or 23.98PsF mode.)	Adjust the "H-crop" (the horizontal position when cropping in the edge crop mode) of the up/down converter output when menu item 930 is set to crop. <b>-120 to 0 to 120</b>
934	CROSS COLOR (DC) (Invalid in 24PsF or 23.98PsF mode.)	Carry out the down-converter cross color adjustment. <b>0 to 8 to 15</b>
935	DETAIL GAIN (DC) (Invalid in 24PsF or 23.98PsF mode.)	Carry out the down-converter image enhancer adjustment. Adjust the sharpness of edge emphasis. <b>0 to 20H to 7FH</b>
936	LIMITER (DC) (Invalid in 24PsF or 23.98PsF mode.)	Carry out the down-converter image enhancer adjustment. Adjust the maximum detail level added to emphasize the original signal. <b>0 to 20H to 3FH</b>
937	CRISP THRESHOLD (DC) (Invalid in 24PsF or 23.98PsF mode.)	Carry out the down-converter image enhancer adjustment. Set the threshold amplitude at which low amplitude signals are not emphasized. <b>0 to FH</b>
938	LEVEL DEPEND THRESHOLD (DC) (Invalid in 24PsF or 23.98PsF mode.)	Carry out the down-converter image enhancer adjustment. Set the luminance range for edge enhancement. <b>0 to 8 to FH</b>
939	H DETAIL FREQUENCY (DC) (Invalid in 24PsF or 23.98PsF mode.)	Carry out the down-converter image enhancer adjustment. Set the central frequency for edge enhancement. <b>2.6MHz to 3.4MHz to 3.9MHz to 4.6MHz</b>
940	H/V RATIO (DC) (Invalid in 24PsF or 23.98PsF mode.)	Carry out the down-converter image enhancer adjustment. Set the horizontal/vertical ratio for edge enhancement. <b>0 to 3 to 7</b>
941	GAMMA LEVEL (DC) (Invalid in 24PsF or 23.98PsF mode.)	Carry out the down-converter image enhancer adjustment. Adjust the slope of the correction curve. <b>0 to 80H to 100H</b>

(Continued)



Menu items in the range 900 to 999, relating to digital processing (Continued)

Item number	Item name	Settings
942	V FILTER SELECT (Invalid in 24PsF or 23.98PsF mode.)	Set the vertical interpolation filter coefficient for HD-SD converter output. The vertical resolution increases as the setting grows larger. <b>1 to 3</b>
943	CROSS COLOR CRISP (Invalid in 24PsF or 23.98PsF mode.)	Set the cross color crisp level for HD-SD converter output. <b>0x00 to 0x04 to 0x0f</b>
950	UP CONVERTER MODE (Invalid in 24PsF or 23.98PsF mode.)	Select the up-converter mode. <b>crop</b> : Select the edge-crop mode. <b>l-box</b> : Select the letter box mode. <b>squez</b> : Select the squeeze mode.
951	H CROP POSITION (UC) (Invalid in 24PsF or 23.98PsF mode.)	Adjust the "H-crop" (the horizontal position when inserting in the edge crop mode) of the up/down converter output when menu item 950 is set to crop. <b>-120 to 0 to 120</b>
952	LETTER BOX POSITION (Invalid in 24PsF or 23.98PsF mode.)	Adjust the vertical position of the letter box mode cutout in up-converter output when l-box is selected in menu item 950. <b>-120 to 0 to 120</b>
953	UP CONVERTER PROCESS SELECT (Invalid in 24PsF or 23.98PsF mode.)	Select the original picture to use when converting SD to HD. <b>FIELD</b> : Use field picture. <b>FRAME</b> : Use frame picture. <b>adapt (standard mode)</b> : Set the ratio of converting from frames or fields to the standard ratio when up-converting. <b>adap2 (still picture priority mode)</b> : Set the ratio of converting from frames higher when up-converting. <b>adap3 (motion priority mode)</b> : Set the ratio of converting from fields higher when up-converting.
954	DETAIL GAIN (UC) (Invalid in 24PsF or 23.98PsF mode.)	Carry out the up-converter image enhancer adjustment. Adjust the sharpness of edge emphasis. <b>0 to 40H to 7FH</b>
955	LIMITER (UC) (Invalid in 24PsF or 23.98PsF mode.)	Carry out the up-converter image enhancer adjustment. Adjust the maximum detail level added to emphasize the original signal. <b>0 to 20H to 3FH</b>
956	CRISP THRESHOLD (UC) (Invalid in 24PsF or 23.98PsF mode.)	Carry out the up-converter image enhancer adjustment. Set the threshold amplitude at which low amplitude signals are not emphasized. <b>0 to 8H to FH</b>
957	LEVEL DEPEND THRESHOLD (UC) (Invalid in 24PsF or 23.98PsF mode.)	Carry out the up-converter image enhancer adjustment. Set the luminance range for edge enhancement. <b>0 to 8 to FH</b>
958	H DETAIL FREQUENCY (UC) (Invalid in 24PsF or 23.98PsF mode.)	Carry out the up-converter image enhancer adjustment. Set the central frequency and frequency characteristic for edge enhancement. <b>3.2MHz</b> : 3.2 MHz ±1.1 MHz <b>4.5MHz</b> : 4.5 MHz ±1.4 MHz <b>5.0MHz</b> : 5.0 MHz ±0.7 MHz <b>4.0MHz</b> : 4.0 MHz ±2.0 MHz
959	H/V RATIO (UC) (Invalid in 24PsF or 23.98PsF mode.)	Carry out the up-converter image enhancer adjustment. Set the horizontal/vertical ratio for edge enhancement. <b>0 to 3 to 7</b>
960	GAMMA LEVEL (UC) (Invalid in 24PsF or 23.98PsF mode.)	Carry out the up-converter image enhancer adjustment. Adjust the slope of the correction curve. <b>0 to 80H to 100H</b>

(Continued)

## 9-4 Items in the Extended Setup Menu

Menu items in the range 900 to 999, relating to digital processing (Continued)

Item number	Item name	Settings
961	BACKGROUND COLOR (UC) (Invalid in 24PsF or 23.98PsF mode.)	<p>Set the color of the part where no material exists (background) for up-converting.</p> <p><b>BACK GROUND COLOR:</b> Set the color.</p> <p><b>BLACK</b> : Black</p> <p><b>GRAY:</b> Gray</p> <p><b>BLUE:</b> Blue</p> <p><b>TABLE:</b> Set with the following Y/P<sub>B</sub>/P<sub>R</sub> tables.</p> <p><b>Y TABLE:</b> Adjust the background Y level. 0 (H) to ff (H)</p> <p><b>B-Y TABLE:</b> Adjust the background B-Y level. 0 (H) to 80 (H) to ff (H)</p> <p><b>R-Y TABLE:</b> Adjust the background R-Y level. 0 (H) to 80 (H) to ff (H)</p>

## 10-1 Removing a Cassette When Tape Slack

If tape slack occurs in the unit, it is necessary to remove the upper lid and sound baffle. This job should always be entrusted to a technician who has undergone service training.

*For details, refer to Section 1-17 in the Installation Manual.*

## 10-2 Head Cleaning

To clean the video heads and audio heads, always use the special-purpose Sony BCT-HD12CL cleaning cassette.

If you insert the cleaning cassette, it is automatically ejected after a head cleaning operation which lasts for 10 seconds.

Follow the instructions with the cleaning cassette carefully, as inappropriate use of the cleaning cassette can damage the heads.

**Note**

You cannot use the BCT-5CLN cleaning cassette.

# 10-3 Error Messages

This unit is equipped with a self-diagnosis function, and if a problem is detected, displays an error message in the time data display and on the monitor. If an error message appears, contact your Sony service representative.

## Indications in the time data display

If a problem is detected, the ALARM indicator in the lower control panel lights, and an error message and error code appear in time data display area 1.

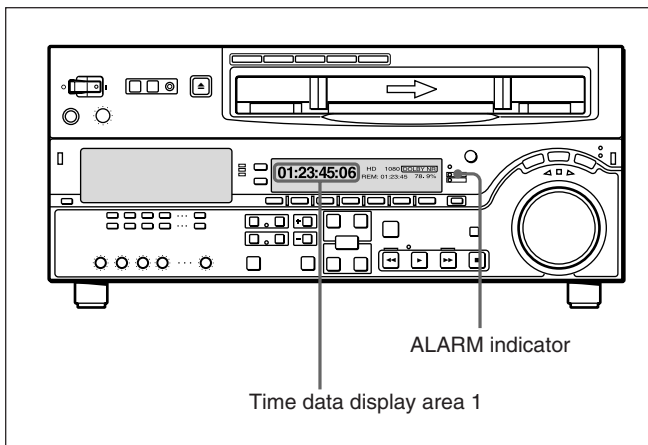

## Error message displays

- To display error messages and codes superimposed on the monitor, set the CHARA in function menu page 4 to ON.
- Some error messages have no associated error codes. In this case, they appear in the time data display.
- Error messages with error codes are saved in non-volatile memory as an error log.
- In some cases the error message is slightly different on the monitor and in the time data display.

## Indications on the monitor

The error message and code also appear superimposed on a monitor connected to the COMPOSITE VIDEO OUTPUT 3(SUPER) connector, HDSDI OUTPUT 3(SUPER) connector, or SDI OUTPUT 3(SUPER) connector. Depending on the error code, an indication of the source of the problem may appear as a secondary error message.

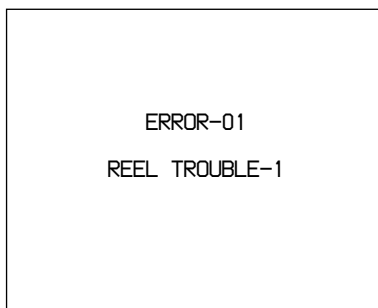

## Error Message List

Code	Message	Description
–	NO COMMUNICATION	Abnormality in the interface between the lower control panel (KY-464/465 board) and SYS CPU (SS-89 board) has been detected on the lower control panel side.
01	REEL TROUBLE	Tape slacking has been detected in the threading or unthreading operation.
02	REEL TROUBLE	Tape slacking or tape breaking has been detected in the SEARCH, FF, or REW mode.
03	REEL TROUBLE	Tape slacking, tape breaking, or supply or take-up reel locking has been detected in the PLAY mode.
04	REEL TROUBLE	A malfunctional tape transport speed has been detected in the FF or REW mode.
05	REEL TROUBLE	A malfunctional operation of the supply or take-up reel has been detected during cassette insertion.
06	TAPE TENSION	Excessive tape tension has been detected in the PLAY mode.
07	CAPSTAN TROUBLE	Malfunction of capstan motor has been detected.
08	DRUM TROUBLE	Malfunction of drum motor has been detected.
09	TH/UNTH MOTOR	Malfunction of threading or unthreading operation has been detected.
0A	THREADING	The tape top processing has not been completed in the threading mode.
10	HUMID	Dew condensation has been detected.
11	TAPE T/E SENSOR	The tape top and tape end have been detected simultaneously.
12	TAPE TOP SENSOR	Malfunction of tape top sensor has been detected.
13	TAPE END SENSOR	Malfunction of tape end sensor has been detected.
14	FAN MOTOR	Malfunction of cooling fan motor has been detected.
20	CASS COMP MOTOR	Malfunction of cassette compartment-up or down operation has been detected.
21	REEL SFT MOTOR	Malfunction of movement of the reel table corresponding to the cassette size has been detected.
22	REEL POS SENSOR	The L-cassette and S-cassette positions of the reel table have been detected simultaneously.
23	THRED RING SENS	The thread end and unthread end states of the threading ring have been detected simultaneously.
92	INTERNAL I/F1	Abnormality in the interface between SYS CPU (on SS-89 board) and other CPU/MPU has been detected.
93	CPU INITIALIZE ERROR	Abnormality in the interface between SV CPU (on SS-89 board) and DRUM CPU (on DR-414 board) has been detected.
95	OTHERS NV-RAM ERROR	Abnormality has been detected in the operation of an NV-RAM on FP-119 board.
96	SY NV-RAM ERROR	Abnormality has been detected in the operation of an NV-RAM (on SS-89 board) for the system control system.
97	SV NV-RAM	Abnormality has been detected in the operation of an NV-RAM (on DR-414 board) for the servo system.
98	RF NV-RAM ERROR	Abnormality has been detected in the operation of an NV-RAM (on EQ-84 board) for the RF system.
99	INTERNAL I/F 2	Abnormality in the interface between SYS CPU (on SS-89 board) and SERVO CPU (on SS-89 board) or MPU (EQ-84, DM-123, HIF-1, VPR-64, APR-52, DPR-195 and DPR-155 board) has been detected.

## 10-4 Moisture Condensation

When the unit is suddenly moved from a cold to a warm location, or used in a very humid place, moisture from the air can condense on the head-drum. This is called moisture condensation. If the tape is run in this state, it can adhere to the drum. To prevent such a condition from occurring, the unit is provided with a moisture detecting function.

If moisture condenses on the head-drum while the unit is in use, the ALARM indicator lights and "ERR-10" is displayed in time data display area 1.

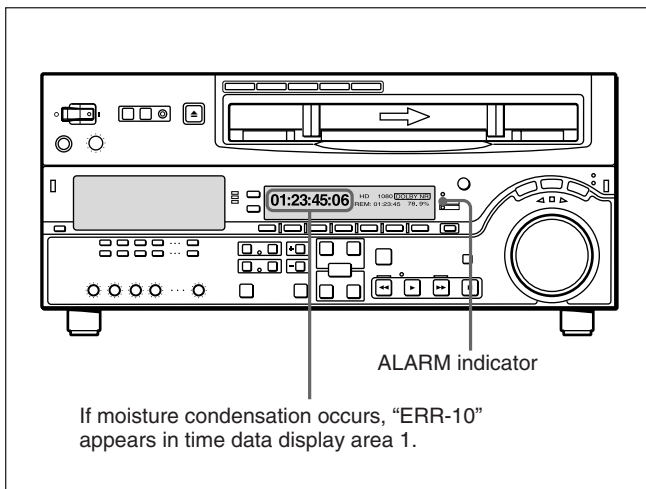

If this happens, the drum and capstan motors stop and the cassette is automatically ejected. Then, the drum starts to rotate again to dry its surface. In this state, the unit is not operable. When the moisture has evaporated, the error message disappears and the ALARM indicator goes off.

### **If "ERR-10" appears and the ALARM indicator lights immediately after powering the unit on**

Leave the unit powered on and wait until the error message disappears and the indicator goes off.

While the indicator is lit, you cannot insert a cassette.

When the indicator goes off and the error message disappears, you can use the unit.

### **If you move the unit from a cold to a warm location**

Leave the unit powered off for about 10 minutes, in order to give the unit time to detect moisture condensation.

# 10-5 Regular Checks

## 10-5-1 Digital Hours Meter

The digital hours meter can display seven items of information, in corresponding display modes, about the operational history of the unit. Use it as a guide in scheduling periodic maintenance.

### Display modes of the hours meter

#### H01: OPERATION mode

Displays the total number of hours the unit has been powered on in units of 1 hour.

#### H02: DRUM RUNNING mode

Displays the total number of hours the drum has run with tape threaded in units of 1 hour.

#### H03: TAPE RUNNING mode

Displays the total number of hours the unit has been in fast forward, rewind, playback, or search (except for stop and still) mode in units of 1 hour.

#### H04: THREADING mode

Displays the total number of times tape has been threaded in the unit.

#### H12: DRUM RUNNING mode (resettable)

Same as H02 except that the count is resettable. This can be used as a guide in determining when to replace the drum.

#### H13: TAPE RUNNING mode (resettable)

Same as H03 except that the count is resettable. This can be used as a guide in determining when to replace such components as fixed heads and pinch rollers.

#### H14: THREADING mode (resettable)

Same as H04 except that the count is resettable. This can be used as a guide in determining when to replace, for example, the threading motor.

### Displaying the digital hours meter

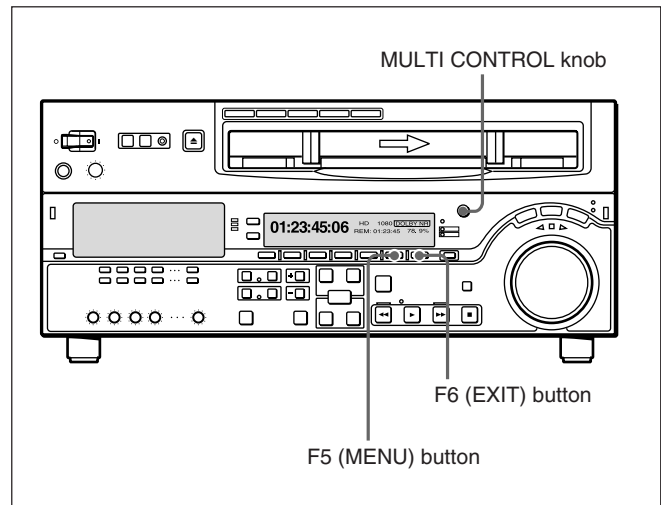

#### To display the digital hours meter

Press the F5 (MENU) button, then turn the MULTI CONTROL knob to display the required item in the time data display.

#### To exit from the hours meter

Press the F6 (EXIT) button.

## 10-5 Regular Checks

### 10-5-2 Maintenance Timings

Use the following table as a timing guide for checking and replacing components of the unit. These intervals are not guaranteed lifetimes; the timing for replacing components depends on the particular conditions of use. In particular, depending on the degree of dirt contamination and abrasion, pinch rollers and cleaners may require replacement earlier than suggested by this table.

Note that an arrow in the table means that the component to be replaced is part of the assembly the arrow points to, which must be replaced as a whole.

*For information on severe conditions (frequent threading/unthreading) or how to replace components, refer to the Maintenance Manual Volume 1.*

Component	Digital hours meter indication (menu number in parenthesis)	Guideline replacement intervals					
		R: Replace		C: Check, and replace if necessary			
		1000 hrs	2000 hrs	3000 hrs	4000 hrs	5000 hrs	6000 hrs
Upper drum	Drum running time (H02)			C	C	C	C(↓)
Drum assembly							C
Brush slip ring assembly				R			R(↑)
Video head cleaner (roller)				R			R
Pinch roller assembly	Tape running time (H03)			R			R
Reel table assembly					R (Replace at interval of 4000 hours.)		
Pinch application assembly	Tape running time (H03)						R
Fan motor (card)	Operation time (H01)	Replace after 40,000 hours					
Fan motor (MD)		Replace after 40,000 hours					
Fan motor (power supply)		Replace after 40,000 hours					

#### Note

Contact a Sony service or marketing representative regarding the replacement and checking of components.



# Specifications

## General

Recording format	HDCAM
Power requirements	100 to 240 VAC, 50/60 Hz
Power consumption	2.2 A (220 W), when used without optional devices
Peak inrush current	(1) Power ON, current probe method: 50 A (240 V), 14 A (100 V) (2) Hot switching inrush current, measured in accordance with European standard EN55103-1: 18 A (230 V)
Appel de courant de crête	(1) Mise sous tension (ON), méthode de sondage du courant: 50 A (240 V), 14 A (100 V) (2) Mesuré conformément à la norme européenne EN55103-1: 18 A (230 V)
Spitzenstrom	(1) Einschaltstrom, Stromsonde: 50 A (240 V), 14 A (100 V) (2) Gemessen in EN55103-1: 18 A (230 V)
Operating temperature	5°C to 40°C (41°F to 104°F)
Storage temperature	-20°C to +60°C (-4°F to +140°F)
Humidity	20 to 90%
Mass	23 kg (50 lb 11 oz)
Dimensions (w/h/d)	427 × 194 × 544 mm (16 <sup>7</sup> / <sub>8</sub> × 7 <sup>3</sup> / <sub>4</sub> × 21 <sup>1</sup> / <sub>2</sub> inches)

## Tape transport system

Tape speed	HDCAM:
	96.7 mm/s (59.94i, 29.97PsF)
	80.6 mm/s (50i, 25PsF)
	77.4 mm/s (24PsF, 23.98PsF)
	Digital Betacam:
	96.7 mm/s
	MPEG IMX:
	64.5 mm/s (525/59.94)
	53.8 mm/s (625/50)
	Betacam SX: 59.6 mm/s
Analog Betacam:	
118.6 mm/s (525/59.94)	
101.5 mm/s (625/50)	

HDCAM record/playback time	124 minutes with BCT-124HDL (59.94i, 29.97PsF)
	149 minutes with BCT-124HDL (50i, 25PsF)
	155 minutes with BCT-124HDL (24PsF, 23.98PsF)
Digital Betacam playback time	124 minutes with BCT-D124L
MPEG IMX record/playback time	184 minutes with BCT-184MXL (525/59.94)
	220 minutes with BCT-184MXL (625/50)
	Betacam SX playback time
Analog Betacam playback time	90 minutes with BCT-90MLA (525/59.94)
	108 minutes with BCT-90MLA (625/50)
	Fast forward/ rewind time
Search speed Shuttle mode	HDCAM playback:
	Still to approx. ±50 times normal playback speed (59.94i, 29.97PsF)
	Still to approx. ±58 times normal playback speed (50i, 25PsF)
	Still to approx. ±60 times normal playback speed (24PsF, 23.98PsF)
	Digital Betacam playback: Still to approx. ±50 times normal playback speed
	MPEG IMX/Betacam SX playback: Still to approx. ±78 times normal playback speed
	Analog Betacam playback: Still to ±35 times normal playback speed (525/59.94)
	Still to ±42 times normal playback speed (625/50)

# Specifications

Variable speed mode	HDCAM playback: -1 to +2 times normal playback speed Digital Betacam playback: -1 to +3 times normal playback speed MPEG IMX playback: -1 to +3 times normal playback speed Betacam SX playback: -1 to +2 times normal playback speed Analog Betacam playback: -1 to +3 times normal playback speed
Jog mode	Still to $\pm 1$ times normal playback speed
Servo lock time	0.6 (59.94i, 29.97PsF)/0.7 (50i, 25PsF) second or less (from standby on)
Load/unload time	6 seconds or less
Recommended tapes	HDCAM cassettes (S, L): BCT-6HD/12HD/22HD/32HD/40HD BCT-34HDL/64HDL/94HDL/124HDL MPEG IMX cassettes (S, L) Digital Betacam cassettes (S, L) Betacam SX cassettes (S, L) Betacam SP cassettes (S, L) Betacam cassettes (S, L)

---

## Digital video system

### Digital video signal system

Sampling frequency	Y: 74.25 MHz R-Y/B-Y: 37.125 MHz
Quantization	8 bits/sample
Compression	Coefficient recording system
Channel coding	S-I-NRZI PR-IV
Error correction	Reed-Solomon code

### Analog component output

Bandwidth	
Y	0 to 5.75 MHz +0.5 dB/-2.0 dB
R-Y/ B-Y	0 to 2.75 MHz +0.5 dB/-2.0 dB
S/N ratio	56 dB or more
K factor (2T pulse)	1% or less

### Analog composite output

Bandwidth (Y)	0 to 5.75 MHz +0.5 dB/ -2.0 dB
S/N ratio	53 dB or more
Differential gain	2% or less
Differential phase	2° or less
Y/C delay	20 ns or less
K factor (2T pulse)	1% or less
Output SCH phase	Based upon RS-170A/CCIR R.624-3 (Adjustable by using the menu)

---

## Digital audio system

### Digital audio (CH1 to CH8) signal format

Sampling frequency	48 kHz (synchronized with video)
Quantization	20 bits/sample
Wow and flutter	Below measurable level
Headroom	20 dB (or 18 dB, selectable)
Emphasis	T1= 50 $\mu$ s, T2=15 $\mu$ s (on/off selectable in recording mode)

### Analog output (CH1 to CH4)

A/D, D/A quantization	20 bits/sample
Frequency response	20 Hz to 20 kHz +0.5 dB/ -1.0 dB (0 dB at 1 kHz)
Dynamic range	95 dB or more (at 1 kHz, emphasis on)
Distortion	0.05% or less (at 1 kHz, emphasis on, reference level (+4 dBm))
Crosstalk	-80 dB or less (at 1 kHz, between any two channels)

---

## Analog audio (CUE)

Frequency response	100 Hz to 12 kHz $\pm 3$ dB
S/N ratio	45 dB or more (THD, 1 kHz, reference level)
Distortion	2% or less (THD, 1 kHz, reference level)
Wow and flutter	0.2 % rms or less

## Digital Betacam playback

### Video

Bandwidth	Y	0 to 5.75 MHz +0.5 dB/-0.5 dB
	R-Y/B-Y	0 to 2.75 MHz +0.5 dB/-0.5 dB
S/N ratio		62 dB or more
K factor		1 % or less

### Digital Audio (CH1 to CH4)

Frequency response	20 Hz to 20 kHz +0.5 dB/-1.0 dB
Dynamic range	95 dB (at 1 kHz, emphasis on)
Distortion	0.05 % rms (emphasis on)
Wow and flutter	Below measurable level

### Analog Audio (cue track)

Frequency response	100 Hz to 12 kHz + 3 dB/-3 dB
S/N ratio (at 3 % distortion level)	45 dB (at 1 kHz)
Distortion	2 % or less
Wow and flutter	0.2 % rms or less

## MPEG IMX playback

### Video

Frequency response	Y	0 to 5.75 MHz +0.5 dB/-3.0 dB
	R-Y/B-Y	0 to 2.75 MHz +0.5 dB/-2.0 dB
S/N ratio		56 dB or more
K factor (2T pulse)		1 % or less

### Digital audio (CH1 to CH4)

Frequency response	20 Hz to 20 kHz +0.5 dB/-1.0 dB (0 dB at 1 kHz)
Dynamic range	90 dB or more (1 kHz, emphasis on, 16 bits/48 kHz)
Distortion	0.05 or less (1 kHz, emphasis on, reference level (+ 4 dBm))

## Betacam SX playback

### Video

Bandwidth	Y	0 to 4.5 MHz +0.5 dB/-3.0 dB
	R-Y/B-Y	0 to 2.0 MHz +0.5 dB/-3.0 dB
S/N ratio		56 dB or more
K factor (2T pulse)		1 % or less

### Digital Audio (CH1 to CH4)

Frequency response	20 Hz to 20 kHz +0.5 dB/-1.0 dB (0 dB at 1 kHz)
Dynamic range	90 dB or more (at 1kHz, emphasis on)
Distortion	0.05 % or less (at 1 kHz, emphasis on, reference level (+4 dBm))

# Specifications

## Analog Betacam playback

### Video

		Metal tape	Oxide tape
Bandwidth	Y	30 Hz to 4.5 MHz +0.5 dB/ -4.0 dB	30 Hz to 4.1 MHz +0.5 dB/ -6.0 dB
	R-Y/ B-Y	30 Hz to 1.5 MHz +0.5 dB/-3.0dB	30 Hz to 1.5 MHz +0.5 dB/-3.0 dB
S/N ratio	Y	51 dB or more	48 dB or more
	R-Y/ B-Y	48 dB or more	45 dB or more
K factor (2T pulse)		2% or less	3% or less
LF non-linearity	Y	3% or less	
	R-Y/ B-Y	4% or less	
Y/C delay		20 ns or less	

### Audio

		Metal tape	Oxide tape
LNG	Frequency response (at 10 dB below reference level <sup>a)</sup> )	50 Hz to 15 kHz +1.5 dB/ -3.0 dB	50 Hz to 15 kHz +3.0 dB
	S/N ratio (at 3% distortion level)	72 dB or more	50 dB or more (Dolby NR off)
	Distortion (THD at 1 kHz reference level <sup>a)</sup> )	1% or less	2% or less
	Wow and flutter	0.1% rms or less	0.1% rms or less
AFM	Frequency response (at reference level <sup>a)</sup> )	20 Hz to 20 kHz +0.5 dB/-2.0 dB	—
	S/N ratio (at 3% distortion level)	85 dB or more	—
	Distortion (THD at 1 kHz reference level <sup>a)</sup> )	0.5% or less	—

a) Reference level: +4 dBm

### Processor adjustment range

Video level	±3 dB/ -∞ to +3 dB selectable
Chroma level	±3 dB/ -∞ to +3 dB selectable
Setup level (59.94i, 29.97PsF mode)	±30 IRE
Black level (50i, 25PsF mode)	±210 mV
Y/C delay	±100 ns (for analog Betacam tapes)
Chroma phase	±30°
System phase	Sync: ±15 µs SC: ±200 ns

### Input connectors

#### REF. VIDEO INPUT

BNC (2 in loop through connection)  
Black burst or composite sync  
0.3 Vp-p, 75 Ω, sync negative

### Output connectors

#### HDSDI OUTPUT

BNC (3 including 1 for character superimposition)  
Serial digital (1.485 Gbits/s)  
SMPTE 292M

#### SDTI OUTPUT

BNC (2) (optional)  
SMPTE 305M (SDTI)

#### COMPONENT VIDEO OUTPUT

BNC (1 set)  
Y: 1.0 Vp-p, Sync negative  
R-Y/B-Y: 0.7 Vp-p, 75 Ω, with 100% or 75% color bar selectable

#### COMPOSITE VIDEO OUTPUT

BNC (3 including 1 for character superimposition)  
1.0 Vp-p, 75 Ω, Sync negative

#### SDI OUTPUT

BNC (3 including 1 for character superimposition)  
Serial digital (270 Mbits/s)  
SMPTE 259 M

AUDIO OUTPUT CH1/2/3/4	XLR 3-pin, male (4) +4 dBm at 600 $\Omega$ load, low impedance, balanced
AUDIO OUTPUT (AES/EBU) CH1/2, 3/4, 5/6, 7/8	BNC (4) Complies with AES-3id-1995
CUE OUT	XLR 3-pin, male (1) +4 dBm at 600 $\Omega$ load, low impedance, balanced
MONITOR OUTPUT (L/R)	XLR 3-pin, male (2) +4 dBm at 600 $\Omega$ load, low impedance, balanced
TIME CODE OUT	XLR 3-pin, male (1) 2.2 Vp-p, low impedance, balanced
PHONES	JM-60 stereo phone jack $-\infty$ to $-12$ dBu at 8 $\Omega$ load, unbalanced

---

### Remote connectors

CONTROL PANEL	10-pin (2), female Front/rear selectable
REMOTE 1-IN(9P)	D-sub 9-pin, female
REMOTE 1-OUT(9P)	D-sub 9-pin, female
RS-232C	D-sub 9-pin, male
VIDEO CONTROL(15P)	D-sub 15-pin, male (for optional BVR-50/50P)
VIDEO CONTROL(9P)	D-sub 9-pin, female (for optional HKDV-900)
REMOTE 2 PARALLEL I/O(50P)	50-pin, female

---

### Memory card insertion slot

PCMCIA

---

### Memory stick slot

Memory stick (8 to 128MB)

---

### Accessories supplied

PSW 4  $\times$  16 screws for rack mounting (4)  
CD-ROM Manual (1)  
Installation Manual (1)  
Operation Guide (1)

---

### Optional accessories

HKDW-101 Control Panel  
BKMW-102 Remote Control Unit  
BKMW-103 Control Panel Extension Kit  
HKDW-102 SDTI Interface Board  
RCC-5G 9-pin remote control cable  
BVR-50/50P Video Remote Control Unit  
HKDV-900 Video Remote Control Unit  
RMM-131 Rack Mount Adaptor  
BCT-HD12CL Cleaning Cassette Tape  
AC power cord

- For customers in the U.S.A. and Canada  
Part No. 1-557-377-11  
Plug holder 3-613-640-01
- For customers in the United Kingdom  
Part No. 1-782-165-11  
Plug holder 3-613-640-01
- For customers in European countries other than the United Kingdom  
Part No. 1-782-164-11  
Plug holder 3-613-640-01

Design and specifications are subject to change without notice.

#### To prevent electromagnetic interference from portable communications devices

The use of portable telephones and other communications devices near this unit can result in misoperations and interference with audio and video signals.

It is recommended that portable communications devices near this unit be powered off.

# Specifications

## Relation between HKDV-900/503 setting items and setup menu of this unit

HKDV-900/503 setting items	Setup menu items of this unit
HD Master	740: MASTER LEVEL (HD) <sup>a)</sup>
HD Y	741: Y LEVEL (HD) <sup>a)</sup>
HD Pb	742: Pb LEVEL (HD) <sup>a)</sup>
HD Pr	743: Pr LEVEL (HD) <sup>a)</sup>
HD Setup	745: SETUP LEVEL (HD) <sup>a)</sup>
HD Sync Phase	746: SYNC PHASE (HD/UC) <sup>a)</sup>
HD Fine	747: FINE (HD/UC) <sup>a)</sup>
D1 Master	No corresponding menu item
D1 Y	No corresponding menu item
D1 B-Y	No corresponding menu item
D1 R-Y	No corresponding menu item
D2 VIDEO	715: VIDEO GAIN CONTROL (HD/DC/SD/UC) <sup>a)</sup>
D2 CHROMA	716: CHROMA GAIN CONTROL (HD/DC/SD/UC) <sup>a)</sup>
D2 HUE	717: CHROMA PHASE CONTROL (HD/DC/SD/UC) <sup>a)</sup>
SETUP	713: VIDEO SETUP REFERENCE LEVEL: OUTPUT LEVEL (DC/SD) <sup>a), c)</sup>
	718: SETUP LEVEL/BLACK LEVEL (HD/DC/SD/UC) <sup>a), c)</sup>
SD Sync Phase	719: SYSTEM PHASE SYNC (DC/SD)
SD Fine	720: SYSTEM PHASE SC (DC/SD)
CROSS COLOR	934: CROSS COLOR (DC)
H CROP POSITION	932: H CROP POSITION (DC)/951: H CROP POSITION (UC) <sup>b)</sup>
DETAIL GAIN	935: DETAIL GAIN (DC)/954: DETAIL GAIN (UC) <sup>b)</sup>
LIMITTER	936: LIMITER (DC)/955: LIMITER (UC) <sup>b)</sup>
CRISP	937: CRISP THRESHOLD (DC)/956: CRISP THRESHOLD (UC) <sup>b)</sup>
DEPEND	938: LEVEL DEPEND THRESHOLD (DC)/957: LEVEL DEPEND THRESHOLD (UC) <sup>b)</sup>
FREQUENCY	939: H DETAIL FREQUENCY (DC)/958: H DETAIL FREQUENCY (UC) <sup>b)</sup>
H/V RATIO	940: H/V RATIO (DC)/959: H/V RATIO (UC) <sup>b)</sup>
GAMMA	941: GAMMA LEVEL (DC)/960: GAMMA LEVEL (UC) <sup>b)</sup>
CROP	930: DOWN CONVERTER MODE/950: UP CONVERTER MODE <sup>b)</sup>
LETTER BOX	930: DOWN CONVERTER MODE/950: UP CONVERTER MODE <sup>b)</sup>
SQUEEZE	930: DOWN CONVERTER MODE/950: UP CONVERTER MODE <sup>b)</sup>

- a) Valid for output only when F1 (V.PROC) in function menu page 2 is set to MENU.
- b) Select whether to set DC or UC with menu item 212 (VIDEO REMOTE CONTROL SELECT). When both are selected (menu item 212 is U&D), both of the corresponding menu settings are made, but this unit's answer values and unity values are the DC values.
- c) Use the submenu of menu item 212 (VIDEO REMOTE CONTROL SELECT) to select whether to set menu item 713 or 718.

**HD:** HDSDI output during HDCAM playback  
**DC:** Down-converted SD (D1 SDI/composite) output during HDCAM playback  
**SD:** SD (D1 SDI/COMPOSITE) output during SD format playback  
**UC:** Upconverted HDSDI output during SD format playback

## HD/SD video output phase settings

For the HD/SD video output phase setting, you can use the maintenance menu.

For details, refer to the Installation Manual.

Item number	Item name	Settings
M3	M3A: OUTPUT PHASE SELECT	M3A0: HD PHASE SEL Select the HD video output signal phase with respect to the reference signal: 0H or -90H (HD) advanced. <b>0H</b> : Output in sync with the reference signal. <b>-90H</b> : Output with the phase delayed by -90H (HD) with respect to the reference signal.
		M3A1: SD PHASE SEL Select the SD video output signal phase with respect to the reference signal: 0H or -2H (SD) advanced. <b>0H</b> : Output in sync with the reference signal. <b>-2H</b> : Output with the phase delayed by -2H (SD) with respect to the reference signal.
		M3A2: SD UPCNV SEL Select whether the SD video output signal phase in SD tape playback should be in sync or one frame delayed. <b>noml</b> : Output the SD video with the phase unchanged. (The HD video output is delayed by one frame with respect to the reference signal.) <b>HD</b> : Output the SD video with the phase delayed by one frame. (The HD video output and SD video output are in phase with the reference signal.)

### Note

The SDDSI (D1) output and component/composite outputs have the same phase.

For details of the audio/timecode output phase, see Setup menu item 338.



## A

AC IN connector 2-15  
ALARM indicator 2-9  
Analog  
    audio output section 2-13  
    video input/output section 2-13  
Audio  
    control section 2-4  
    monitor signal output section 2-16  
    monitor signal selection buttons 2-5  
    setting display section 2-4  
AUDIO OUTPUT (AES/EBU) connectors 2-14  
AUDIO OUTPUT CH1 to CH4 connectors 2-13

## B

Basic setup menu items 9-7

## C

C PHAS (function menu) 8-4  
CAPSTN (function menu) 8-6  
Cassettes 3-6  
CHANNEL CONDITION indicator 2-5  
CHARA (function menu) 8-6  
CHROMA (function menu) 8-4  
COMPONENT VIDEO OUTPUT connectors 2-14  
COMPOSITE VIDEO OUTPUT connectors 2-14  
Connections to digital devices 3-1  
Connector panel 2-13  
CONTROL PANEL connector  
    connector panel 2-15  
    switch panel 2-12  
Control panels 2-1  
CTL/TC (function menu) 8-3  
CUE OUT connector 2-13  
CUE/PLAY button 2-10

## D

DELETE button 2-10  
DF (function menu) 8-3  
DF indicator 2-6  
Digital  
    audio output section 2-14  
    device connection 3-1  
    hours meter 10-5  
    signal output section 2-14  
DISPLAY FULL/FINE button 2-4  
DMC  
    EDIT button 2-10  
    playback 4-1  
    playback control point setting buttons 2-10  
DOLBY (function menu) 8-6  
Drop frame  
    mark 3-5  
    mode 8-3

## E

Editing control section 2-10  
EJECT button 2-2  
EMPHSS (function menu) 8-5  
ENTRY button 2-10  
Error messages 10-2  
Extended setup menu items 9-10  
External device connectors 2-15

## F

F FWD button 2-9  
Features 1-1  
F1 to F6 buttons 2-5  
Format indicators 2-2  
Function menu  
    configuration 8-1  
    item 8-2  
    operation 2-5, 8-1

## G

Ground terminal 2-15

## H

HDCAM 1-1  
    cassettes 3-6  
HDSDI OUTPUT connectors 2-14  
Head cleaning 10-1  
Headphones 2-2  
HOME button 2-5  
HUE (function menu) 8-4

## J

JOG  
    button 2-8  
    indicator 2-8  
Jog mode 4-3

## K

KEY INHI indicator 2-9  
KEY INHI switch 2-11

## L

LEARN button 2-11  
Level meter 2-4  
Line standard indicator 2-6  
LIST button 2-11  
Location and function of parts  
    connector panel 2-13  
    lower control panel 2-3  
    switch panel 2-11  
    upper control panel 2-2  
LTC indicator 2-6

## M

MARK button 2-11  
Memory card  
    ejection button 2-12  
    slot 2-12  
Memory stick 3-8  
MEMORY indicator 2-10  
MENU (function menu) 8-3  
Menu  
    control buttons 2-5  
    function menu 8-1  
    setup menus 9-1  
    display section 2-6  
    shot mark operation menu 5-2  
Moisture condensation 10-4  
MONITOR OUTPUT R/L connectors 2-16  
MULTI CONTROL knob 2-7

## N

Non-drop frame  
    mark 3-5  
    mode 8-3

## O

Operation mode 3-5

## P

PANEL SELECT switch 2-12  
Parts replacement 10-6  
PB controls 2-5  
PHONES jack/control 2-2  
PLAY button 2-9  
PLAY IN/OUT buttons 2-10  
Playback  
    capstan override 4-4  
    dynamic motion control (DMC) 4-6  
    jog mode 4-3  
    normal 4-2  
    shuttle mode 4-3  
    variable speed mode 4-4  
Power supply section 2-15  
POWER switch 2-2  
Preparations for playback 4-1  
PREROLL button 2-9  
PUSH/SHIFT indicator 2-7

## R

RECINH (function menu) 8-6  
REC/ERASE indicator 2-11  
REF. VIDEO INPUT connectors 2-14  
Reference signal connection 3-2  
Regular checks 10-5  
REMOTE buttons 2-2  
REMOTE 1-IN(9P) connector 2-15  
REMOTE 1-OUT(9P) connector 2-15

(Continued)



## REMOTE 2 PARALLEL I/O(50P)

connector 2-15

RESET button 2-7

REW button 2-9

RS-232C

connector 2-15

indicator 2-2

---

## S

SC (function menu) 8-5

SDI OUTPUT connectors 2-14

SDTI OUTPUT connectors 2-14

Search control section 2-7

Search dial 2-8

SERVO indicator 2-9

Setup 3-3

SETUP (function menu) 8-4

Setup menu

basic menu items 9-7

configuration 9-1

extended menu items 9-10

menu bank operations 9-5

operations 9-2

Shot data 5-7

Shot mark function

cuing up 5-6

list operations 5-4

operation menu 5-2

operations 5-3

overview 5-1

reading 5-3

sorting 5-8

writing 5-3

Shot mark section 2-11

SHUTTLE button 2-7

Shuttle mode 4-3

SHUTTLE/VAR indicator 2-8

Specifications A-1

Speed indication area 2-7

STANDBY button 2-9

STOP button 2-9

STUNT IN/OUT buttons 2-10

Superimposed character information 3-4

Switch panel 2-11

SYNC (function menu) 8-5

System configurations 1-3

System frequency indicator 2-6

---

## T

T INFO (function menu) 8-5

Tape format indicator 2-6

Tape transport control section 2-9

TCR (function menu) 8-3

Tele-File

attribute data 6-11

clip data 6-3

format 6-12

memory label 6-1

overview 6-1

resume 6-10

undo 6-10

TIME CODE OUT connector 2-16

Time code output section 2-16

Time data 3-4

display 2-6

TRIM buttons 2-10

---

## U

UMID

display 7-2

output 7-2

overview 7-1

Upper control panel 2-2

---

## V

VAR button 2-8

Variable speed mode 4-4

VIDEO (function menu) 8-4

VIDEO CONTROL(15P) connector 2-15

VIDEO CONTROL(9P) connector 2-15

Video test signal (setup menu item 710)

9-20

VITC

field 3-5

indicator 2-6

V.PROC (function menu) 8-4

---

## Y

YC DLY (function menu) 8-4

The material contained in this manual consists of information that is the property of Sony Corporation and is intended solely for use by the purchasers of the equipment described in this manual.

Sony Corporation expressly prohibits the duplication of any portion of this manual or the use thereof for any purpose other than the operation or maintenance of the equipment described in this manual without the express written permission of Sony Corporation.

HDW-M2100/M2100P  
(SY)  
3-206-137-15(1)

Sony Corporation

<http://www.sony.net/>

© 2001

## Free Manuals Download Website

<http://myh66.com>

<http://usermanuals.us>

<http://www.somanuals.com>

<http://www.4manuals.cc>

<http://www.manual-lib.com>

<http://www.404manual.com>

<http://www.luxmanual.com>

<http://aubethermostatmanual.com>

Golf course search by state

<http://golfingnear.com>

Email search by domain

<http://emailbydomain.com>

Auto manuals search

<http://auto.somanuals.com>

TV manuals search

<http://tv.somanuals.com>