



# Instruction Sheet

## MODEL SB1269

### TAPER ATTACHMENT



## ⚠️ WARNING

**This taper attachment is heavy! Get assistance when installing this accessory on the lathe. Wear heavy duty leather boots for foot and toe protection, and keep hands and fingers away from all pinch points. Ignoring this warning can lead to a severe crushing injury or finger amputation!**



## Specifications

- Fits Lathe Models ..14" x 40" SB1012, SB1013  
..... 16" x 60" SB1014, SB1015  
..... 16" x 40" SB1037, SB1038
- Taper Per Inch Range.....0–18"
- Minor Inch Scale Divisions.....0.010"
- Major Inch Scale Divisions.....0.020"
- Taper Angle Range .....0–10°
- Minor Taper Scale Divisions .....1/2°
- Major Taper Scale Divisions.....1°
- Maximum Length of Taper..... 12 1/4"
- Taper Adjustment Knob ..... Yes
- Construction.....Steel
- Unit Weight..... 78 lbs
- Origin..... Taiwan

## Introduction

The Model SB1269 taper attachment was designed to fit onto a series of South Bend lathes. Shown in **Figure 1**, is a Model SB1012 lathe that is fitted with the Model SB1269 taper attachment.

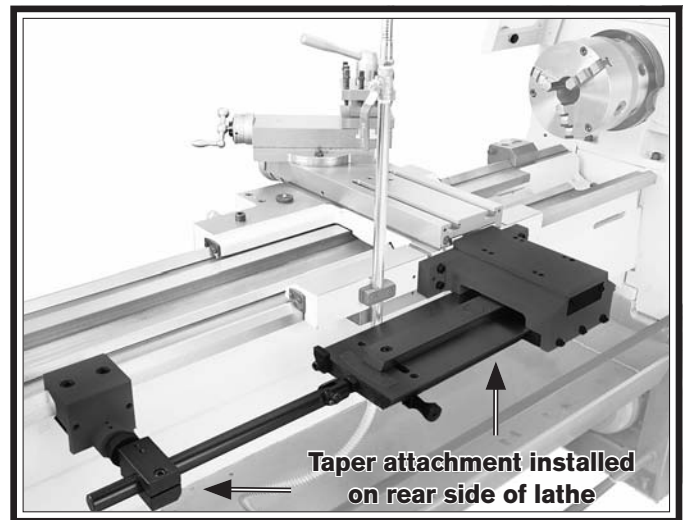

**Figure 1. Model SB1269 installed.**

This taper attachment mounts quickly to the back bed way of your lathe. Accurate tapers of up to 12" can be produced without repositioning the attachment or having to offset the talstock.

The Model SB1269 features scales at both ends, reading inches-per-foot and degrees. An angle adjusting knob with fine threads achieves exacting control when setting tapers.

Another feature is the ability to use the taper attachment without disengaging the cross slide nut. This design allows the taper attachment to be functional at any time by simply tightening the two deadman-clamp cap screws, which lock the deadman-clamp to the rear lathe way.

*If you need help with your new item, contact us at: (360) 734-1540 • FAX: (360) 676-1075*

# Identification

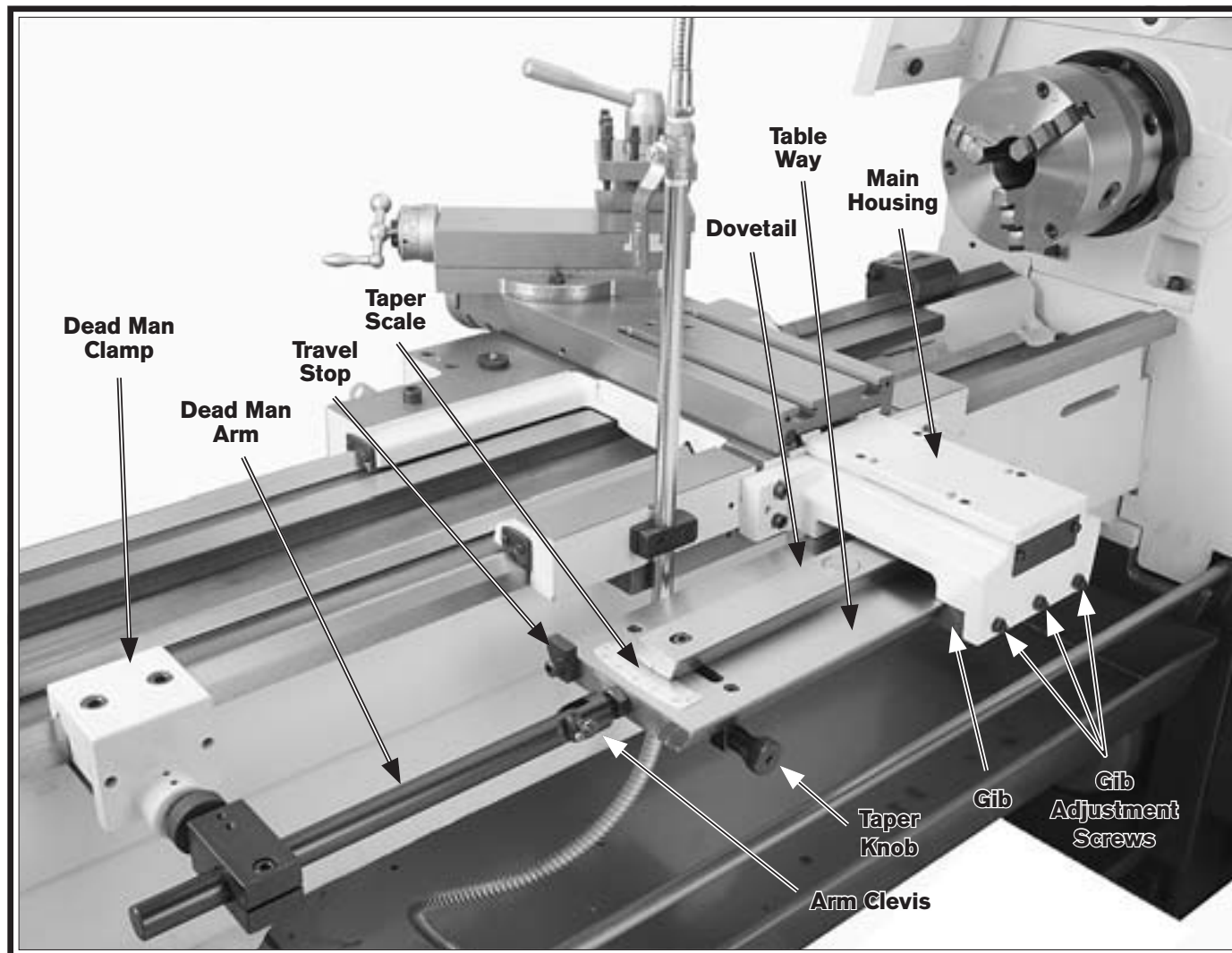

Figure 2. Identification.

## ⚠ WARNING

Serious personal injury could occur if you connect the lathe to power before completing the installation process. **DO NOT** connect power until instructed to do so later in this manual.

## ⚠ WARNING

Untrained users have an increased risk of seriously injuring themselves with this lathe accessory. Do not operate lathe until you have understood this entire manual and received proper training.

## Unpacking

This item was carefully packaged to prevent damage during transport. If you discover any damage, please immediately call Customer Service at (360) 734-1540 for advice. You may need to file a freight claim, so save the containers and all packing materials for possible inspection by the carrier or its agent.

## Inventory

When you are completely satisfied with the condition of your shipment, you should inventory the contents.

<b>Inventory (Figure 3)</b>	<b>Qty</b>
A. Cap Screws M10-1.5 x 40mm (Taper Attachment Mounting) .....	4
B. Taper Attachment Assembly .....	1
C. Tapered Pins 8.7 x 7.7 x 47mm .....	2
D. Copper Anti-Score Plug .....	1
E. Deadman Clamp Assembly .....	1
F. Deadman Arm and Clevis .....	1

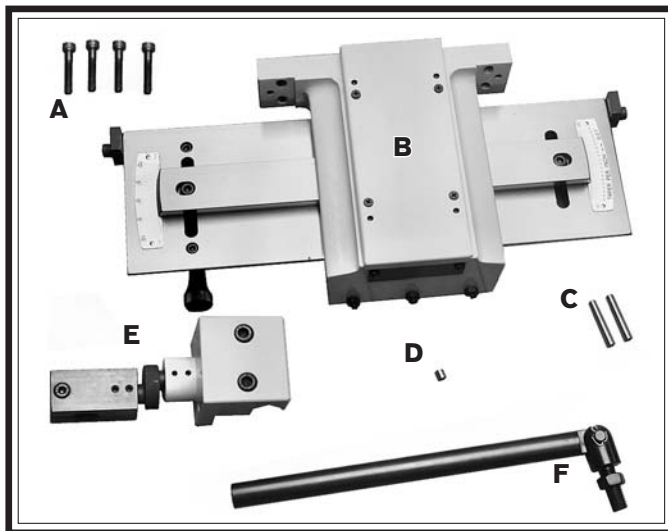

Figure 3. Model SB1269 inventory.

## Things You'll Need

This attachment is intended to be a permanent installation. Installation will take approximately 1.2 hours and require the following items:

### For Assembly

- Cotton Rags
- Mineral Spirits
- Safety Glasses
- Oil Can with any Basic Machine Oil
- Assistant
- Open End Wrench (17mm)
- Hex Wrenches (3, 4, 5, 6, and 8mm)
- Tapered Drill Bit (8mm)
- Safety Glasses
- Oil Can with Pressure Tip
- Dila Indicator with Magnetic Base
- Phillips Screwdriver, #2
- Hammer
- Drill Bit,  $\frac{19}{64}$ "
- Spiral Pin Reamer, Industrial Size: 6
  - Small End Diameter: 0.2773"
  - Large End Diameter: 0.3540"

## Cleaning & Protecting

The unpainted surfaces are coated with a heavy-duty rust preventative that prevents corrosion during shipment and storage.

This rust preventative has been a close ally and guardian since this item left the factory. If the unpainted surfaces are free of rust, then be thankful that the rust preventative did its job...and try to stay thankful as you clean it off, because it can be challenging to remove if you are unprepared and impatient.

Plan on spending time cleaning and removing the rust preventative. The time you spend doing this will reward you with smooth sliding parts and a better appreciation for the proper care of the unpainted surfaces.

Although there are many ways to successfully remove the rust preventative, these instructions walk you through what works well for us.

### Before cleaning, gather the following:

- Disposable Rags
- Cleaner/degreaser
- Safety glasses & disposable gloves

**Note:** Automotive degreasers, mineral spirits or WD•40 can be used to remove rust preventative. Before using these products, though, test them on an unnoticeable area of a painted area to make sure they will not damage it.

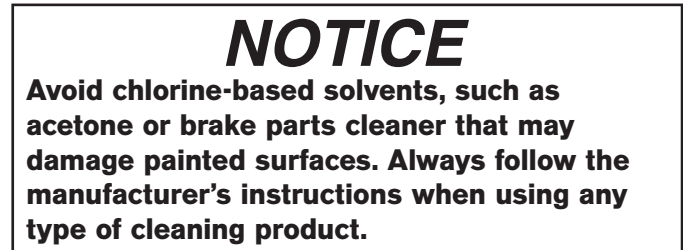
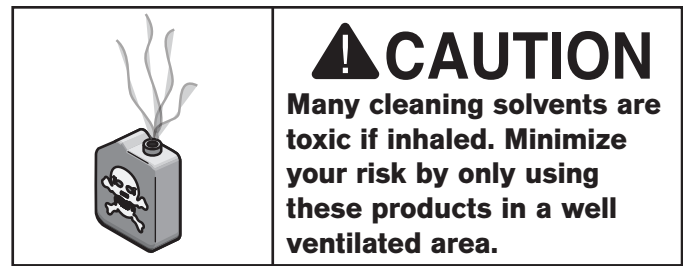
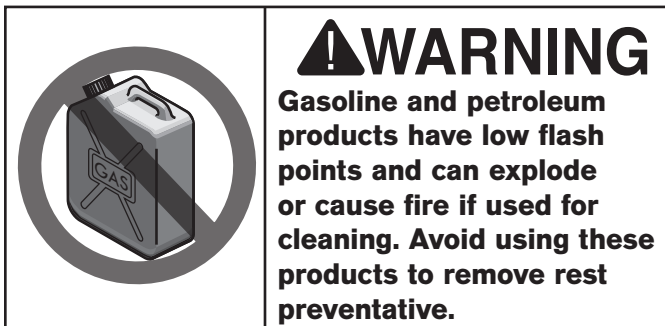

### Basic steps for removing rust preventative:

1. Put on safety glasses and disposable gloves.
2. Coat all surfaces that have rust preventative with a liberal amount of your cleaner or degreaser and let them soak for few minutes.
3. Wipe off the surfaces. If your cleaner or degreaser is effective, the rust preventative will wipe off easily.

**Note:** To clean off thick coats of rust preventative on flat surfaces, such as beds or tables, use a PLASTIC paint scraper to scrape off the majority of the coating before wiping it off with your rag. (Do not use a metal scraper or it may cause scratches.)

4. Repeat **Steps 2-3** as necessary until clean, then coat all unpainted surfaces with a quality metal protectant to prevent rust.

# Installation

## To install the taper attachment:

1. DISCONNECT LATHE FROM POWER!
2. With the assistance of a helper and using a 6mm hex wrench, remove the four cap screws holding the splash guard on the rear of the lathe.
3. Using a 5mm hex wrench, remove the two leadscrew end-cap cap screws shown in **Figure 4**.

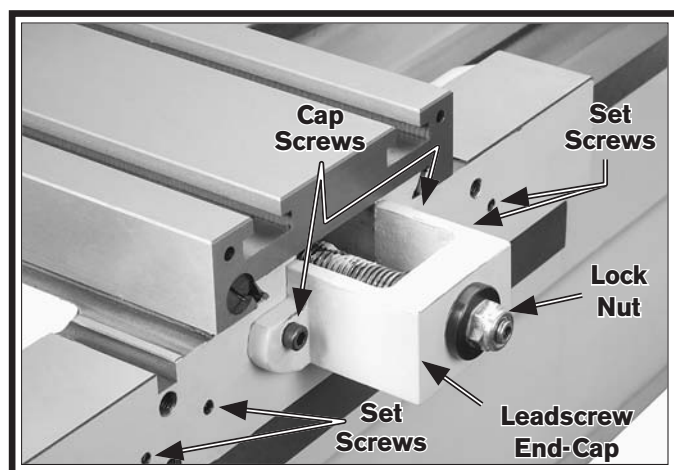

**Figure 4. Lead screw end-cap.**

4. Using a 3mm hex wrench, remove the four set screws (**Figure 4**) from the saddle.
5. Using a 17mm wrench, remove the lock nut (**Figure 4**) from the end of the lead screw.
6. Slide the end-cap off the lead screw. Make sure that the inner and outer race shown in **Figure 4** do not stick to the end-cap.

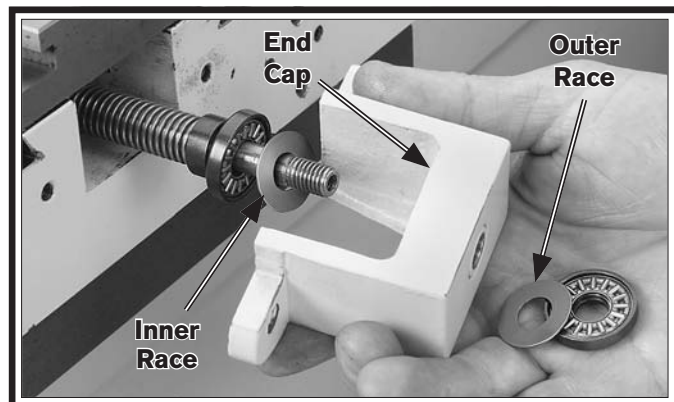

**Figure 5. End-cap removal.**

**Note:** Make sure to keep the correct race with its original bearing, and do not hammer on the casting or chisel the inner races out. The inner race has a loose fit. If it is difficult to remove from its seat, be patient and spray some penetrating oil into the bore and carefully work the race out from the grease suction that is holding it. You can also soak the casting in mineral spirits to break this suction.

7. Using a #2 Phillips screwdriver, remove the eight flat head screws and the taper attachment top plate (**Figure 6**).



**Figure 6. Top plate removal.**

8. Using a 5mm hex wrench, loosen the slide block set screw, as shown in **Figure 7**.

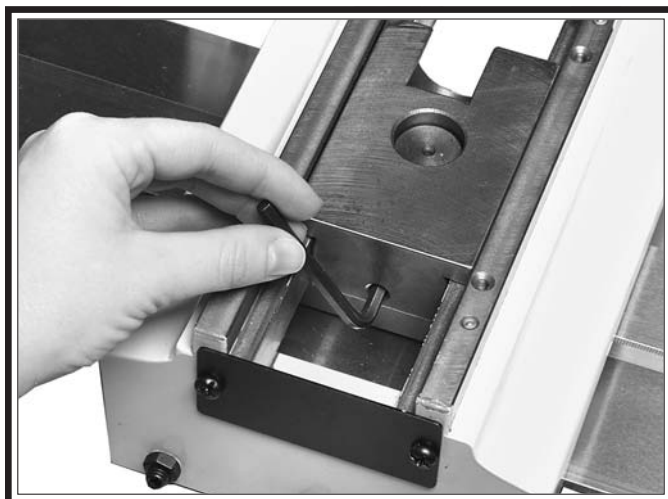

**Figure 7. Slide block removal.**

9. Lift out the slide block without losing the copper anti-score plug (**Figure 8**).

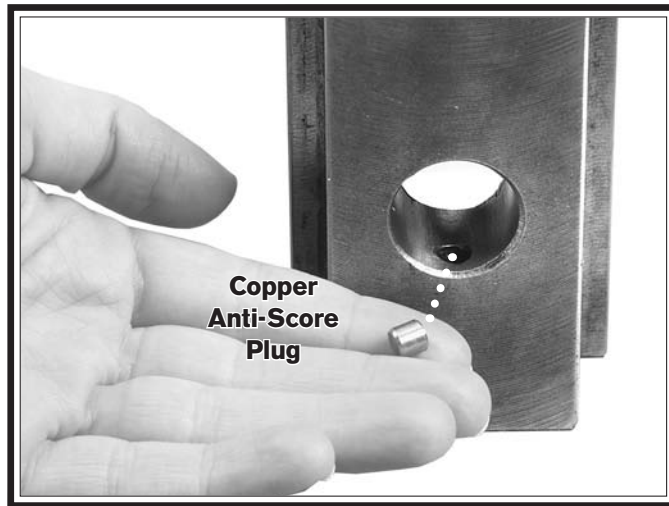
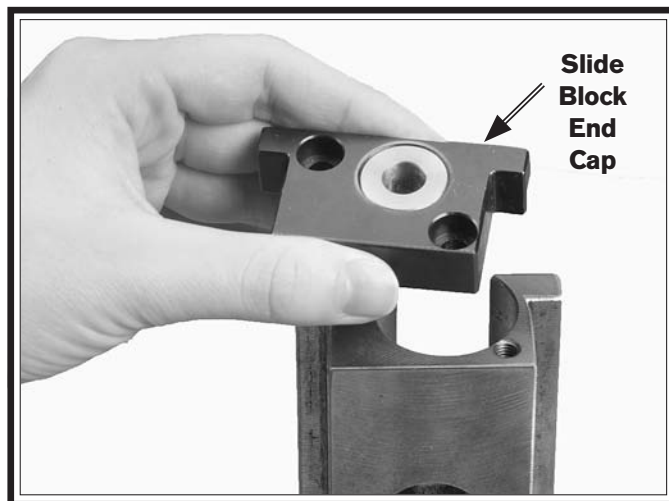

**Figure 8. Slide block copper anti-score plug.**

10. Apply a dab of multi-purpose grease to the copper plug to prevent it from falling out when handling the slide block.

**Note:** This copper plug prevents the set screw from scoring the main pivot pin when the taper attachment is being used.

11. Using a 5mm hex wrench, remove the two cap screws that retain the slide block, and remove the slide block end-cap as shown in **Figure 9**.



**Figure 9. Slide block end-cap removal.**

12. Clean the bearings and races with mineral spirits, then dry and repack them with white lithium grease.
13. Install the bearings and races onto the leadscrew in the order shown in **Figure 10**.

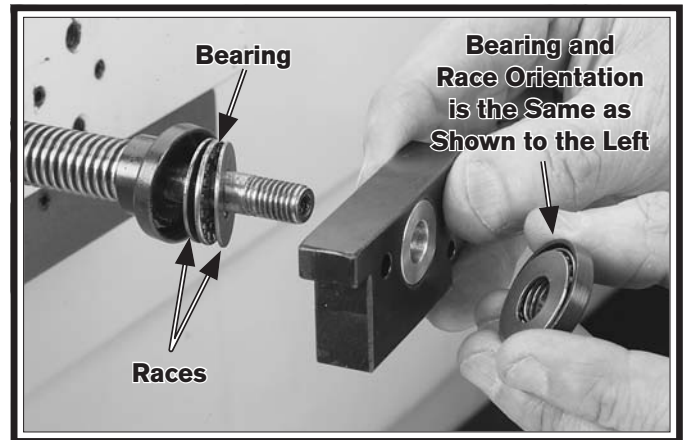

**Figure 10. Slide block end-cap installation, (bearings shown without grease for clarity).**

14. Using a 17mm wrench, thread the lock nut onto the lead screw until the bearings are slightly preloaded, and the slide-block end cap has zero end play.
15. Using a 5mm hex wrench, secure the slide block onto the endcap with the two previously removed cap screws, as shown in **Figure 11**.

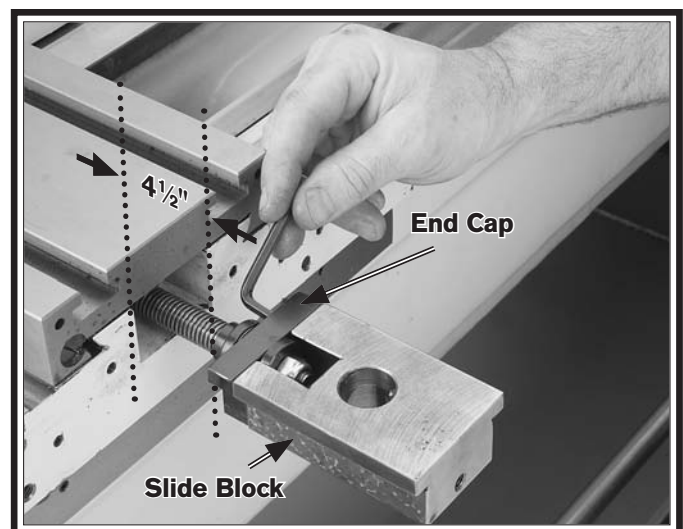

**Figure 11. Slide block installation.**

16. Pull or push the cross slide assembly so the center of the pivot pin bore is 4½" from the carriage face, as shown in **Figure 11**.

17. Make sure the copper plug is still inside of the slide block.
18. With the help of an assistant, raise the taper attachment underneath the slide block, so the pivot pin slides into the pin bore in the slide block (see **Figure 12**).
19. With your assistant aligning the taper attachment mounting holes, use an 8mm hex wrench to tighten the four mounting cap screws and secure the taper attachment to the carriage face (see **Figure 12**).

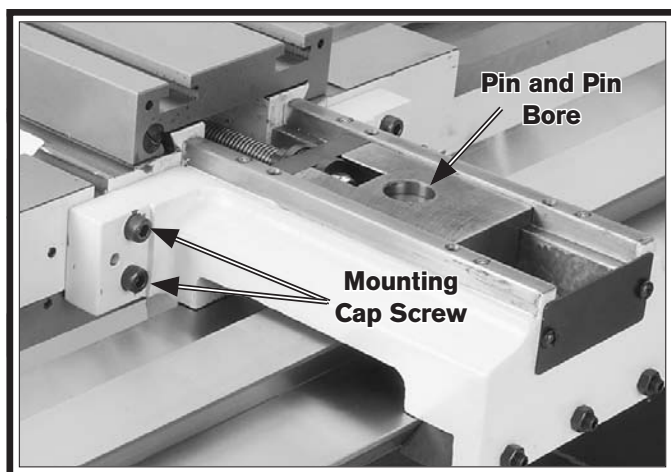

**Figure 12. Taper attachment installation.**

20. Using a 4mm hex wrench, snug the slide block set screw so the copper plug is slightly preloaded against the pivot pin (see **Figure 13**).

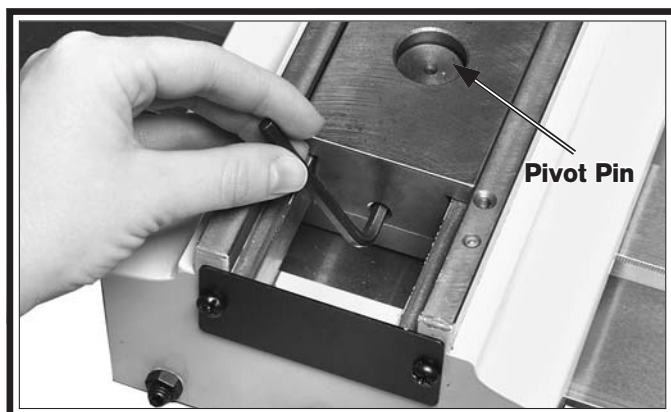

**Figure 13. Pin adjustment.**

21. Apply drops of oil liberally at all four way oil ports, both slide block ways, and the pivot pin shown in **Figure 14**.

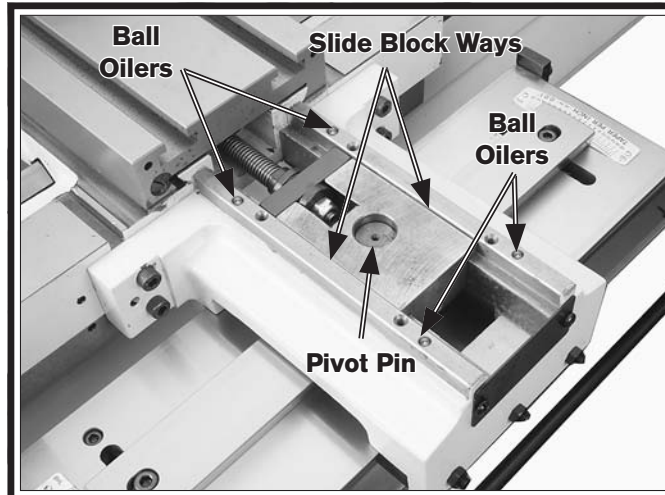

**Figure 14. Lubrication locations.**

22. Reinstall the top plate as shown in **Figure 15**.

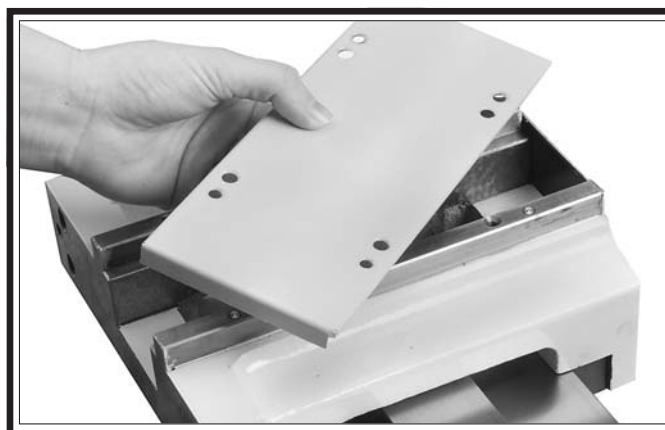

**Figure 15. Top plate installation.**

23. Slide the deadman clamp onto the lathe way, thread the arm clevis into the taper attachment, and then slide the arm clamp onto the deadman arm, as shown in **Figure 16**. Do not tighten the mounting cap screws or arm clevis at this time.

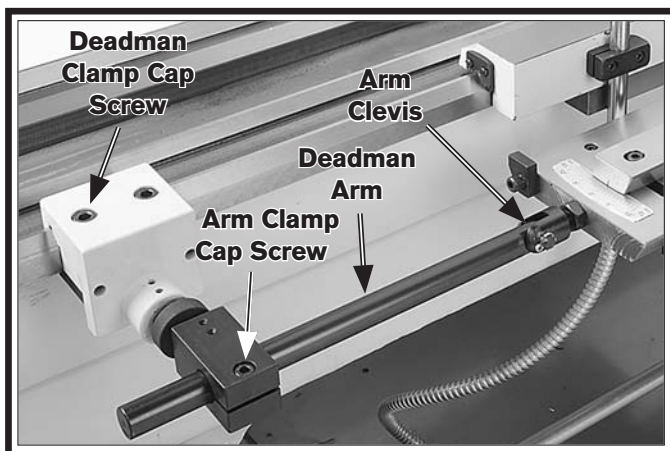

Figure 16. Deadman and arm installation.

24. Using a 6mm hex wrench, loosen the dovetail lock cap screw at each end of the taper attachment, as shown in **Figure 17**.

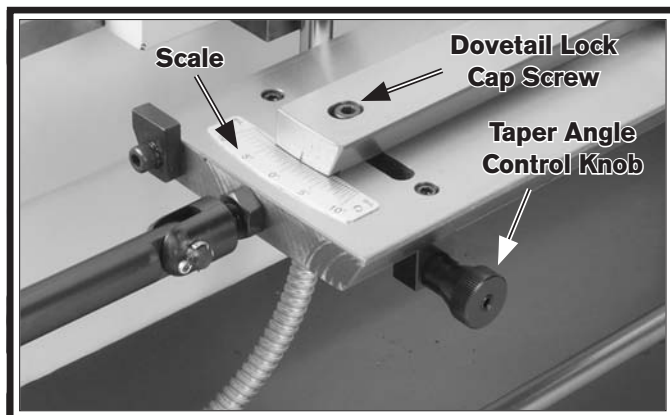

Figure 17. Taper angle adjustment.

25. Turn the taper angle control knob (**Figure 17**), so the taper attachment points to zero degrees as shown on the scale.
26. Re-tighten both dovetail lock cap screws.
27. Slide the deadman clamp along the lathe way to a position where the saddle will not contact the clamp when cutting tapers. There should be approximately 1" of safety clearance or "saddle safety gap," as shown in **Figure 18**. You must double check this clearance to prevent a deadman clamp carriage crash.

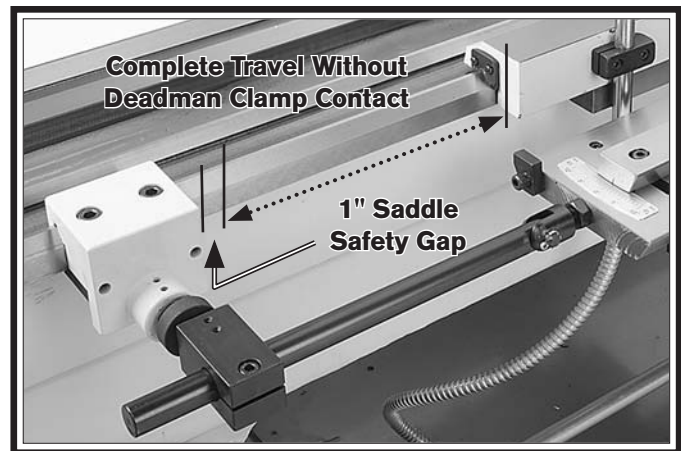

Figure 18. Saddle gap.

28. Using a 3mm hex wrench, loosen the four locking set screws (**Figure 19**) that lock the adjustment cam in position.

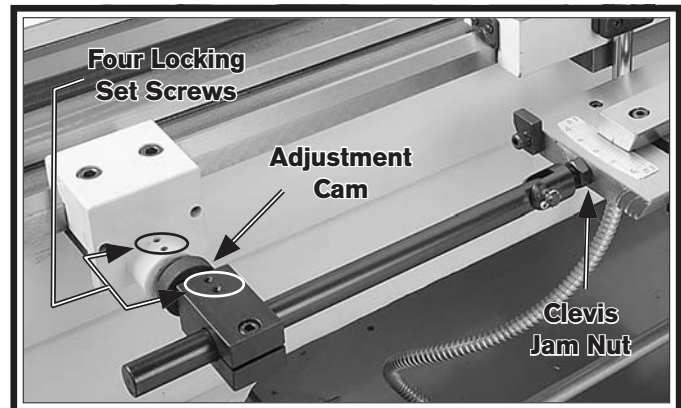

Figure 19. Deadman arm alignment.

29. Rotate, push in, or pull out the adjustment cam to adjust the deadman arm so it is as parallel as possible with the lathe bed in both the vertical and horizontal plane.

**Note:** You may have to rotate the deadman arm so the arm clevis allows the arm to be tilted in a particular direction.

- To tilt the arm in the vertical plane, rotate the knurled adjustment cam.
- To tilt the arm in the horizontal plane, slide the adjustment cam in or out of the deadman housings.



30. Using a 3mm hex wrench, tighten the cam set screws and the clevis jam nut (see **Figure 16**) when finished.
31. Using 8mm and 6mm hex wrenches, tighten the deadman clamp and the arm clamp cap screws, as shown in **Figure 18**.
32. Move the carriage so the taper attachment stops completely at the forward-most position, as shown **Figure 20**.



**Figure 20. Taper attachment alignment.**

33. Setup a knob indicator as shown in **Figure 20**, so the knob indicator point is against the top of the dovetailed table.
34. Move the carriage to the other end of the way, read the knob indicator, and note the amount of total misalignment in parallelism between the path of the carriage and the path of the taper attachment.
  - If the knob indicator readings show a tilt of 0.025" or less between the two extreme positions of the taper attachment, then the alignment is acceptable. Go to go to **Step 37**.
  - If the parallelism is greater than 0.025", proceed to **Step 35**.

35. Loosen the four mounting cap screws and rotate the taper attachment left or right to correct the alignment (see **Figure 21**).

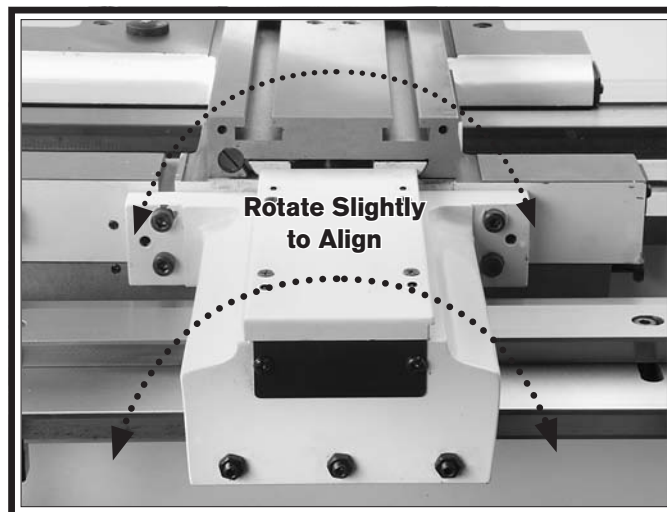

**Figure 21. Parallelism correction.**

36. Retighten the taper attachment cap screws, and double check your parallelism.
37. Using the existing pilot holes in the taper attachment housing as guides (see **Figure 22**), drill out both holes with a  $1/8$ " drill bit, and ream both holes with an industrial size #6 spiral pin reamer deep enough so the tapered pins fit flush. If you need to remove the tapered pins for any reason, the internal pin threads are a metric M6-1.

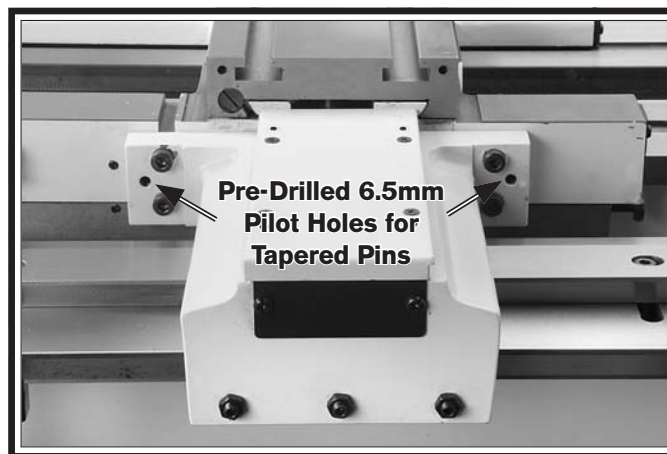

**Figure 22. Roll pin installation.**

38. Position and tap-in the tapered pins, so they will permanently lock the taper attachment in the current alignment position.
39. Reinstall the lathe splash guard.

## Operation

When the deadman clamp cap screws are loose, the deadman clamp slides along the lathe way, and the taper attachment is disengaged. Normal lathe turning operations can be conducted.

When the deadman clamp cap screws are tightened, the deadman clamp is locked to the lathe way, and the taper attachment is engaged. At this point tapered turning operations can be made.

### To use the taper attachment:

1. DISCONNECT LATHE FROM POWER!
2. Move the carriage, cross slide, and compound rest so your turning bit is at your needed location to begin the tapered cut.
3. Using an 8mm hex wrench, tighten both deadman cap screws so the deadman clamps against the lathe bedway, as shown in **Figure 23**.

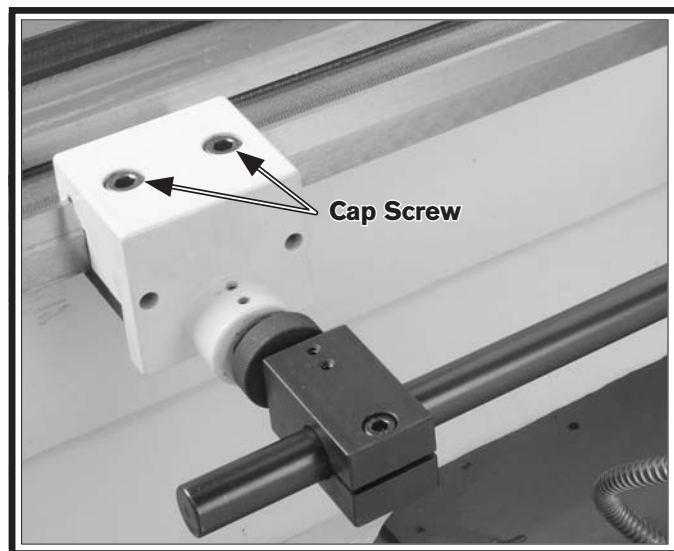

**Figure 23. Deadman clamp location.**

4. Using a 6mm hex wrench, loosen the dovetail lock cap screw at each end of the taper attachment, as shown in **Figure 24**.

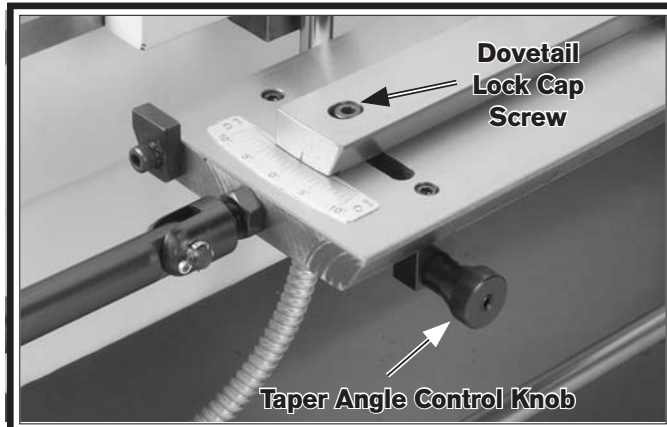

**Figure 24. Taper angle control knob.**

5. Turn the taper angle control knob (see **Figure 24**) until you reach the taper angle or the taper-per-inch setting that you need. Refer to **Figure 25** to select which scale best suits your needs.

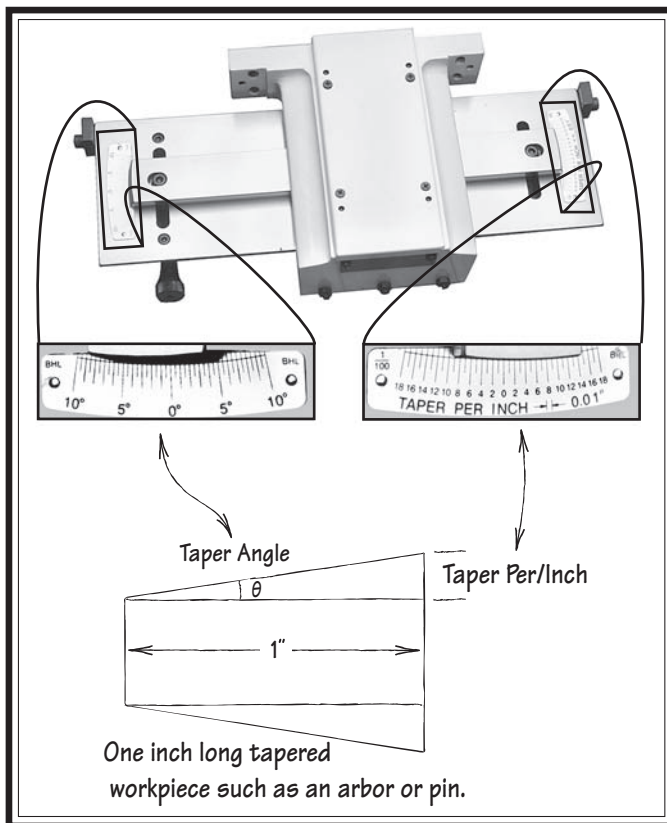
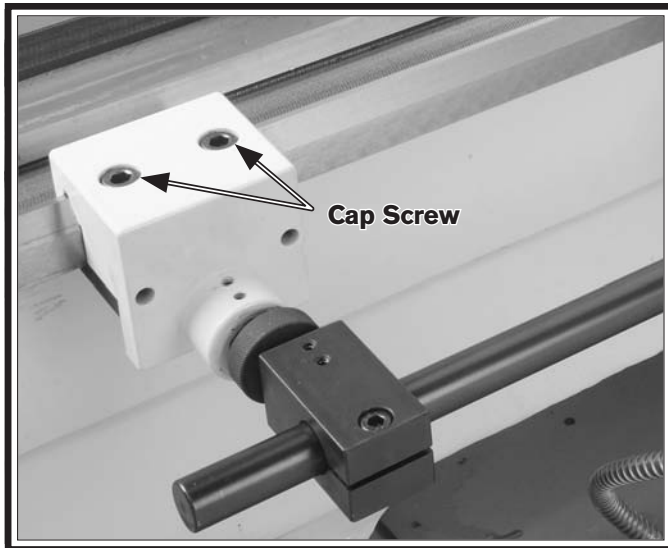

**Figure 25. Scale relationship with workpiece.**

6. Retighten both dovetail lock cap screws.
7. Begin lathe operations.

**To disable the taper attachment:**

1. DISCONNECT LATHE FROM POWER!
2. Use an 8mm hex wrench, and loosen both deadman clamp cap screws shown in **Figure 26**, so the deadman can slide on the way as the carriage is moved.



**Figure 26. Deadman clamp location.**

3. Using a 6mm hex wrench, loosen both dovetail lock cap screws (one end shown in **Figure 27**).

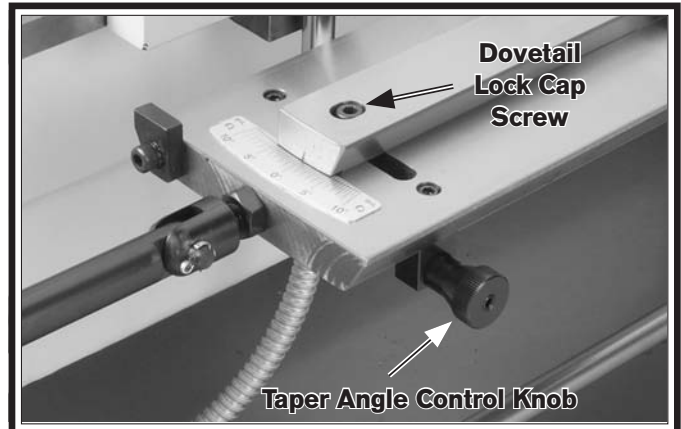

**Figure 27. Taper angle control knob.**

4. Turn the taper angle control knob until you reach "0" as indicated by the taper scale.
5. Using a 6mm hex wrench, tighten both dovetail lock cap screws.

# Maintenance Schedule

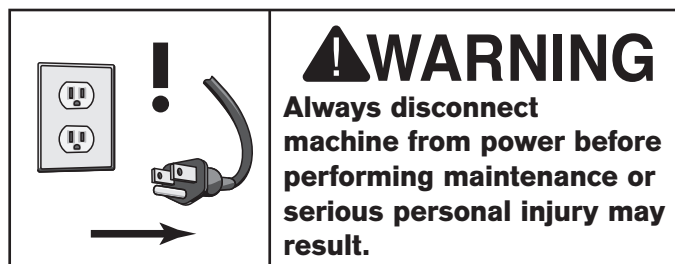

For optimum performance from your taper attachment, follow this maintenance schedule and refer to any specific instructions given in this section.

## Daily:

- Check/correct loose mounting bolts.
- Clean/protect table.
- Clean metal chips and coolant residue from all surfaces.
- Lubricate ball oilers.
- Correct any other unsafe condition.

## Monthly:

- Lubricate pivot pin and slide block ways.

## To lubricate the taper attachment:

1. DISCONNECT LATHE FROM POWER!
2. Using an oil can with the same oil you use on your lathe ball oilers, apply liberal amounts of oil to the four ball oilers, the pivot pin, and the dovetail surface shown in **Figures 28–30**.

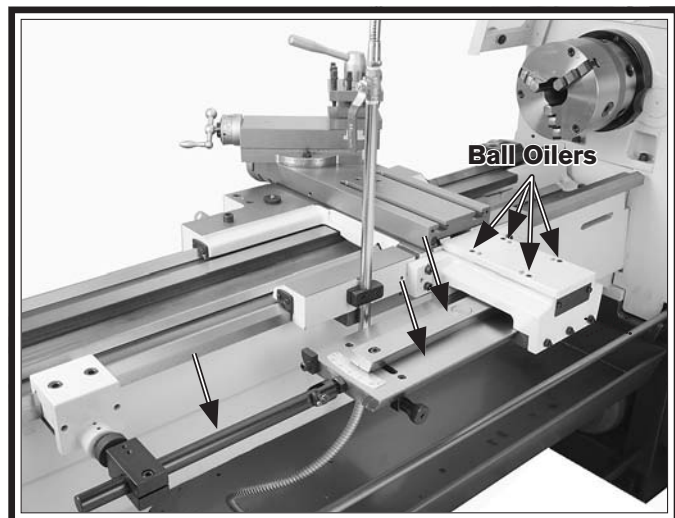

Figure 28. Lubrication locations.

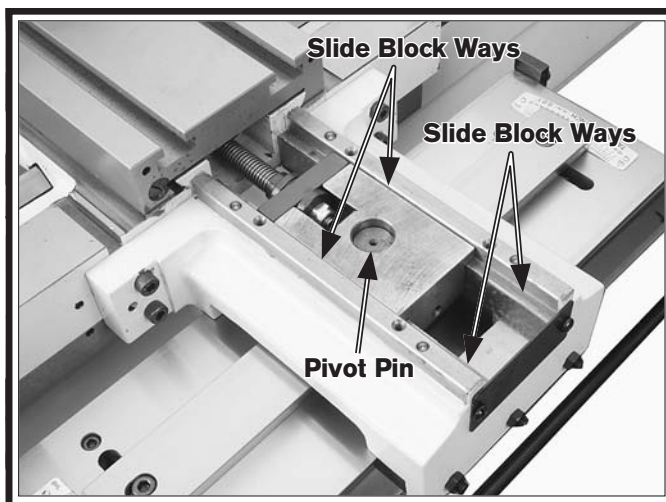

Figure 29. Lubrication locations.

3. Using an oil can with the same oil you use on your lathe ball oilers, apply oil on the knob threads shown in **Figure 30**.

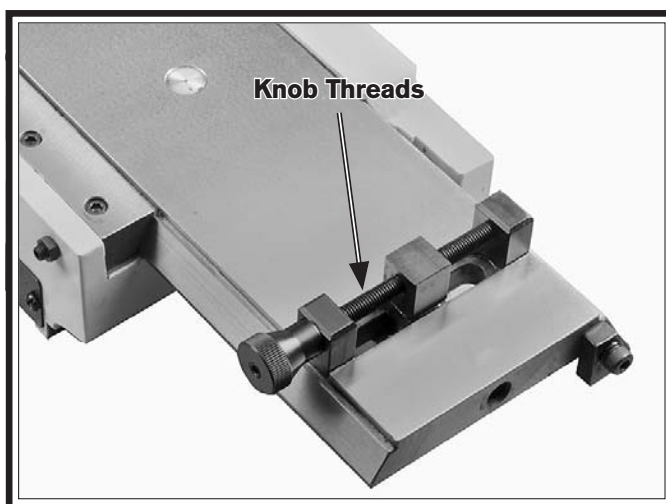

Figure 30. Lubrication locations.

## To clean the taper attachment:

1. DISCONNECT LATHE FROM POWER!
2. Vacuum excess metal chips and wipe off the remaining metal, coolant, and oils with a dry cloth.

If any coolant sludge has built up, use mineral spirits to remove, and then relubricate with the same oil you use on your lathe to prevent surface rust.

# Taper Attachment Breakdown

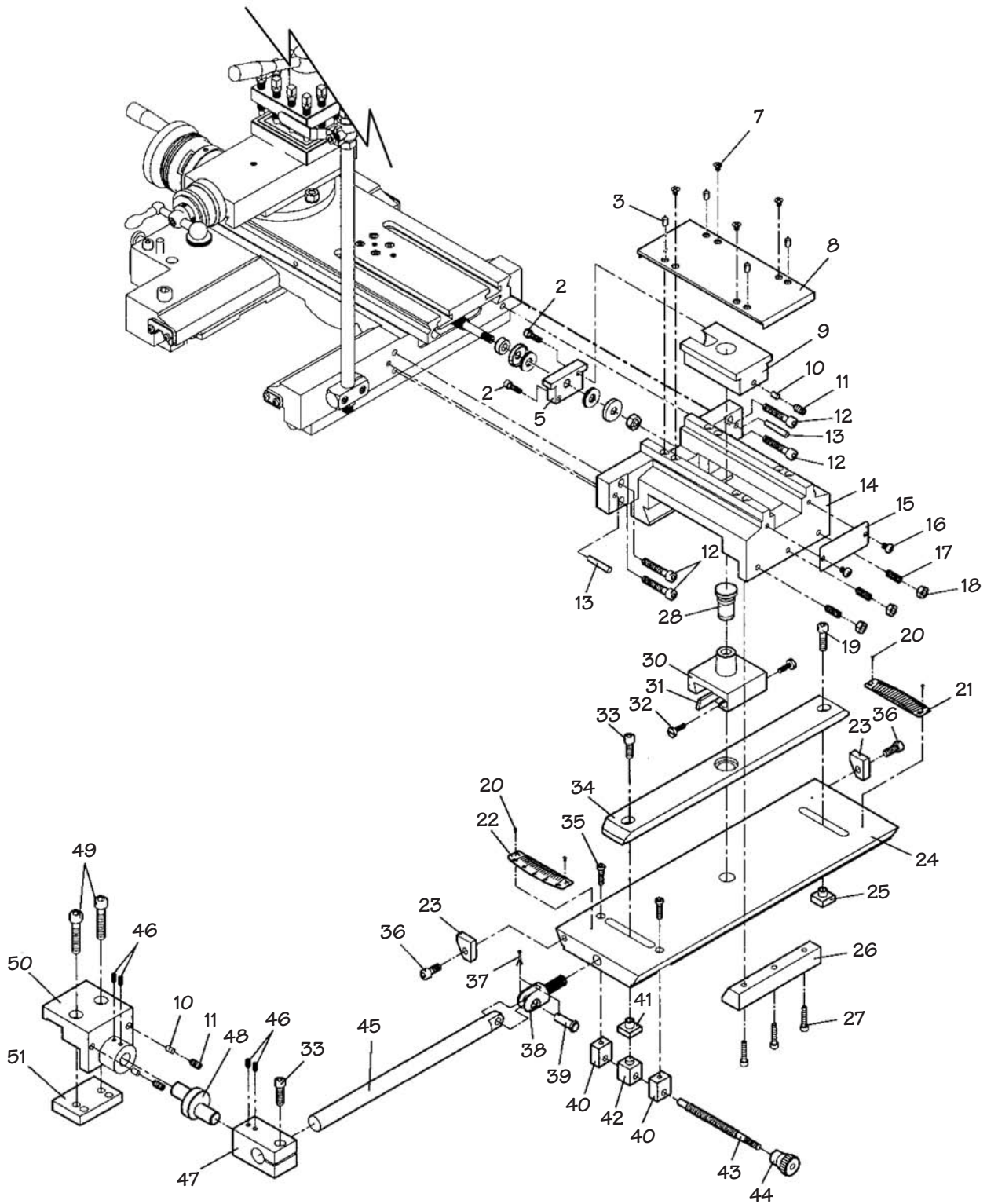

# Parts List

REF	PART #	DESCRIPTION
2	PCAP02M	CAP SCREW M6-1 X 20
3	PSB1269003	BALL OILER
5	PSB1269005	END CAP
7	PFHO4M	FLAT HD SCR M6-1 X 8
8	PSB1269008	COVER PLATE
9	PSB1269009	SLIDE BLOCK
10	PSB1269010	COPPER PIN
11	PSS06M	SET SCREW M8-1.25 X 16
12	PCAP45M	CAP SCREW M8-1.25 X 45
13	PSB1269013	TAPERED PIN
14	PSB1269014	MAIN HOUSING
15	PSB1269015	PLATE
16	PS68M	PHLP HD SCR M6-1 X 10
17	PSS21M	SET SCREW M8-1.25 X 25
18	PNO3M	HEX NUT M8-1.25
19	PCAP13M	CAP SCREW M8-1.25 X 30
20	PSB1269020	STAINLESS RIVET
21	PSB1269021	SCALE TAPER-PER-INCH
22	PSB1269022	SCALE DEGREE
23	PSB1269023	STOP
24	PSB1269024	TABLE
25	PSB1269025	T-NUT M8-1.25
26	PSB1269026	GIB
27	PCAP07M	CAP SCREW M6-1 X 30

REF	PART #	DESCRIPTION
28	PSB1269028	PIN
30	PSB1269030	PIVOT SADDLE
31	PSB1269031	GIB
32	PSB1269032	GIB SCREW
33	PCAP31M	CAP SCREW M8-1.25 X 25
34	PSB1269034	DOVETAIL
35	PCAP06M	CAP SCREW M6-1 X 25
36	PCAP14M	CAP SCREW M8-1.25 X 20
37	PSB1269037	COTTER PIN 4.5 X 30MM
38	PSB1269038	CLEVIS
39	PSB1269039	CLEVIS PIN
40	PSB1269040	NUT BLOCK M6-1 X 25
41	PSB1269041	T-NUT M8-1.25
42	PSB1269042	NUT BLOCK
43	PSB1269043	LEADSCREW
44	PSB1269044	KNOB
45	PSB1269045	DEADMAN ARM
46	PSS04M	SET SCREW M6-1 X 12
47	PSB1269047	ARM CLAMP
48	PSB1269048	ECCENTRIC CAM
49	PCAP143M	CAP SCREW M10- 1.5 X 50
50	PSB1269050	DEADMAN CLAMP
51	PSB1269051	PLATE

---

## WARRANTY

---

This quality product is warranted by South Bend Lathe Company to the original buyer for one year from the date of purchase. This warranty does not apply to consumable parts, or defects due to any kind of misuse, abuse, negligence, accidents, repairs, alterations or lack of maintenance. We do not reimburse for third party repairs. In no event shall we be liable for death, injuries to persons or property, or for incidental, contingent, special or consequential damages arising from the use of our products.

We do not warrant or represent that this machine complies with the provisions of any law, act, code, regulation, or standard of any domestic or foreign government, industry, or authority. In no event shall South Bend's liability under this warranty exceed the original purchase price paid for this machine. Any legal actions brought against South Bend Lathe Company shall be tried in the State of Washington, County of Whatcom.

This is the sole written warranty for this machine. Any and all warranties that may be implied by law, including any merchantability or fitness, for any purpose, are hereby limited to the duration of this warranty. To take advantage of this warranty, contact us by mail or phone to give us the details of the problem you are having.

Thank you for your business and continued support.

Copyright © February, 2010 By South Bend Lathe Co. Revised April, 2010 (CR).  
**WARNING:** No portion of this manual may be reproduced in any shape or form  
without the written approval of South Bend Lathe Co.  
#CR12550 Printed in Taiwan.  
**[www.southbendlathe.com](http://www.southbendlathe.com)**



## Free Manuals Download Website

<http://myh66.com>

<http://usermanuals.us>

<http://www.somanuals.com>

<http://www.4manuals.cc>

<http://www.manual-lib.com>

<http://www.404manual.com>

<http://www.luxmanual.com>

<http://aubethermostatmanual.com>

Golf course search by state

<http://golfingnear.com>

Email search by domain

<http://emailbydomain.com>

Auto manuals search

<http://auto.somanuals.com>

TV manuals search

<http://tv.somanuals.com>