

**REQUIRED TOOLS  
AND MATERIALS:**

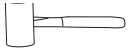

• *Two (2) capable adults*



• *Hammer*



• *Safety Glasses*

• *(2 each) Wrenches and/or Socket Wrenches and Sockets (Deep-Well Sockets are Recommended).*

• *Extension is Recommended.*

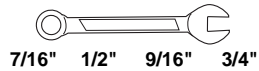

AND/OR

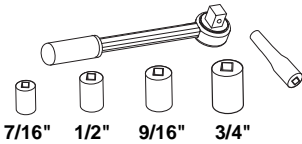

# Sports Table Owner's Manual

Customer Service Center

• N53 W24700 South Corporate Circle • Sussex, WI 53089 • U.S.A.

**Adult Assembly Required.**

This manual, accompanied by sales receipt, should be saved and kept on hand as a convenient reference, as it contains important information about your model.

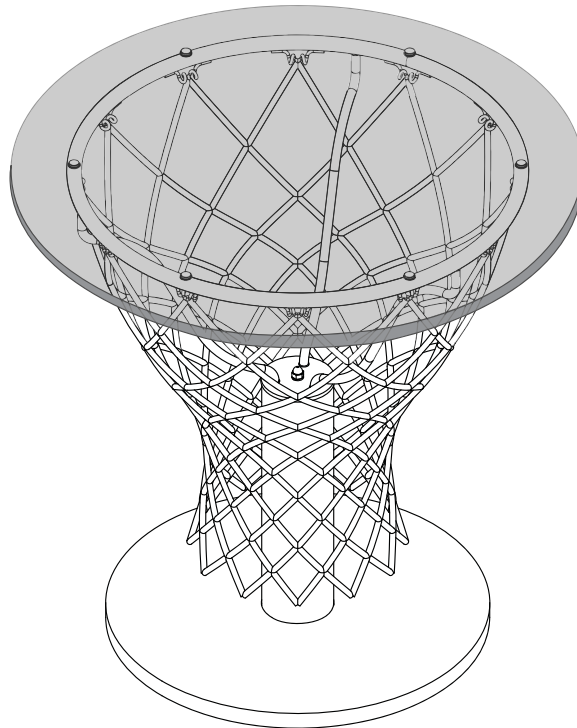

**OPTIONAL TOOLS  
AND MATERIALS:**

• *Large and Small Adjustable Wrenches*

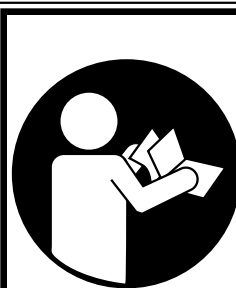
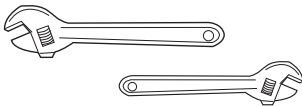

**! WARNING!**

READ AND UNDERSTAND  
OPERATOR'S MANUAL  
BEFORE USING THIS UNIT.

FAILURE TO FOLLOW  
OPERATING INSTRUCTIONS  
COULD RESULT IN INJURY  
OR DAMAGE TO  
PROPERTY.

**Write Model Number  
From Box Here:**

Toll-Free Customer Service Number for U.S: 1-800-558-5234,

For Canada: 1-800-284-8339,

For Europe: 00 800 555 85234 (Sweden: 009 555 85234),

For Australia: 1-800-632 7921

Internet Address: <http://www.huffysports.com>

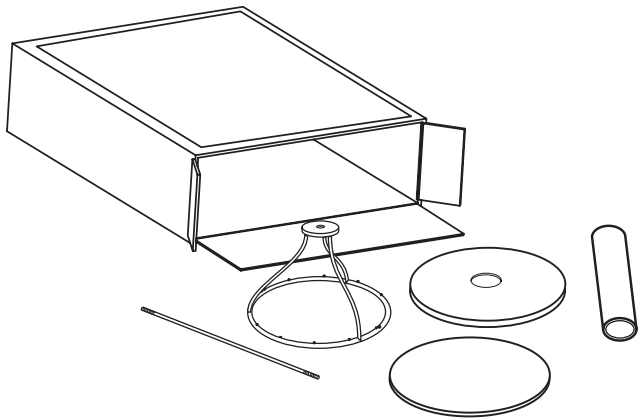

**IMPORTANT!**  
 Remove all contents from boxes.  
 Be sure to check inside pole sections,  
 hardware and additional parts are packed inside.



Questions or Missing Parts?

**DON'T go back to the store!**

Call TOLL-FREE Customer Service  
 number listed on the front page!

### NOTICE TO ASSEMBLERS

**Adult Assembly Required. Dispose of ALL packaging materials promptly. As with all products, periodically inspect for loose small parts.**

	<b>WARNING!</b>
<p><b>IF YOUR SYSTEM IS EQUIPPED WITH AN ACRYLIC BACKBOARD, EXAMINE BACKBOARD FOR ANY DAMAGE THAT MAY HAVE OCCURRED DURING SHIPMENT. CRACKS IN THE BACKBOARD COULD RESULT IN SUDDEN BREAKAGE. IF BACKBOARD IS DAMAGED IN ANY WAY PRIOR TO OR AFTER ASSEMBLY, CALL TOLL-FREE NUMBER:</b>          U.S. 1-800-558-5234; CANADA: 1-800-284-8339; <a href="http://www.huffysports.com">http://www.huffysports.com</a></p>	

**PRODUCT REGISTRATION:**  
 Please remember to complete your product registration form on-line at:  
[www.huffysports.com/customer\\_support/product\\_registration](http://www.huffysports.com/customer_support/product_registration).

### **PARTS LIST - See Hardware Identifier**

<input checked="" type="checkbox"/> <u>Item</u> <u>Qty.</u> <u>Part No.</u> <u>Description</u>	<input checked="" type="checkbox"/> <u>Item</u> <u>Qty.</u> <u>Part No.</u> <u>Description</u>
<input type="checkbox"/> 1 1 908400 Rim, Table Support	<input type="checkbox"/> 8 1 206141 Nut, Jam, 1/4-20
<input type="checkbox"/> 2 1 208131 Table Top, Acrylic	<input type="checkbox"/> 9 1 906133 Pole, (Black)
<input type="checkbox"/> 3 1 Net	<input type="checkbox"/> 10 1 205856 Screw, Phillips Head
<input type="checkbox"/> 4 1 600057 Base, Laminated	<input type="checkbox"/> 11 1 206142 Nut, Acorn, 1/4-20
<input type="checkbox"/> 5 4 206146 Glider, Feet	<input type="checkbox"/> 12 6 206147 Bumpers, (Clear)
<input type="checkbox"/> 6 1 205673 Rod, 1/4-20 x 13-1/8 Long	<input type="checkbox"/> 13 2 203006 Wrench, 7/16"
<input type="checkbox"/> 7 2 206144 Washer, Large	

<b>NOTE:</b>	
	<p>You may have extra parts with this model.</p> <p>Hardware kit is designed for more than one style of basketball system. Not all hardware will be used.</p>

# HARDWARE IDENTIFIER (NUTS AND WASHERS)

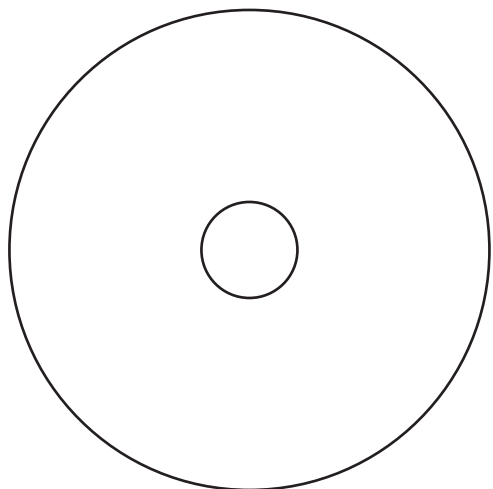

#7 (2)



#8 (1)



#11 (1)



#10 (4)

Get to know the basic parts  
of your system...

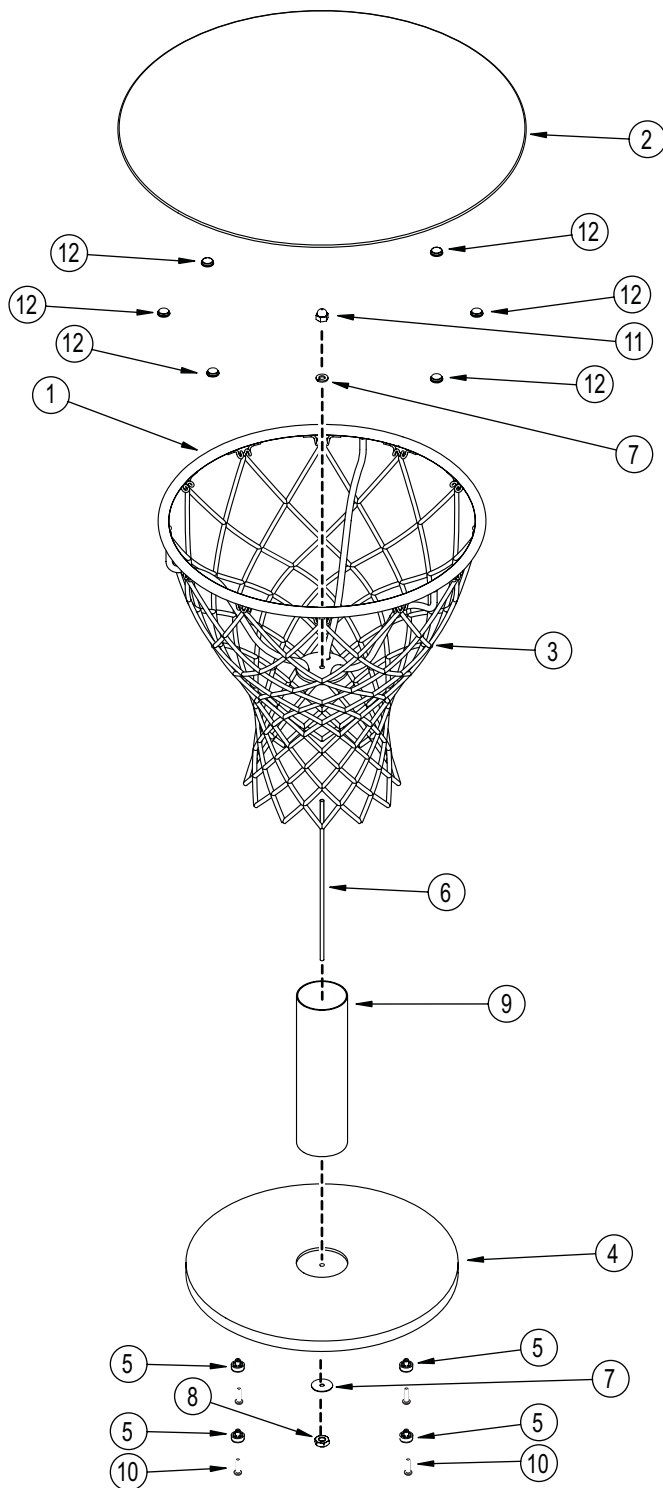

- 1.** Screw glider feet (5) into the bottom surface of the table base (4) as shown.

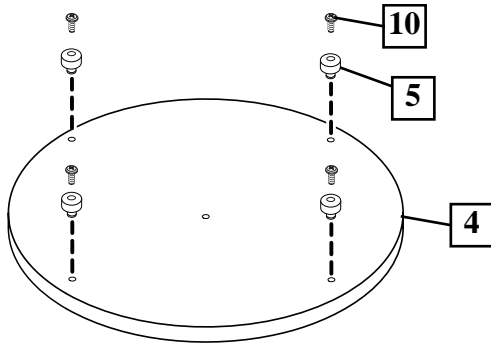

- 2.** Place the rod (6) through the table base (4) and install flat washer (7) and jam nut (8) as shown.

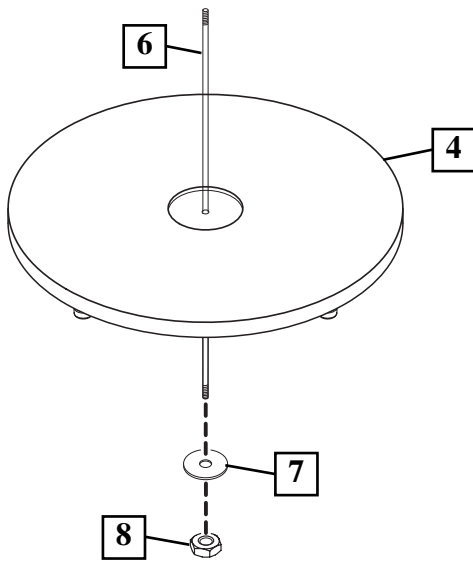

- 3.** Position pole (9) over the rod (6) and into the recessed location on the base (4) as shown.

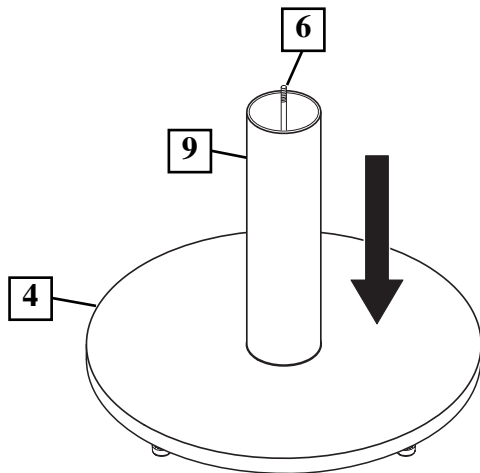

- 4.** Install net (3) as shown.

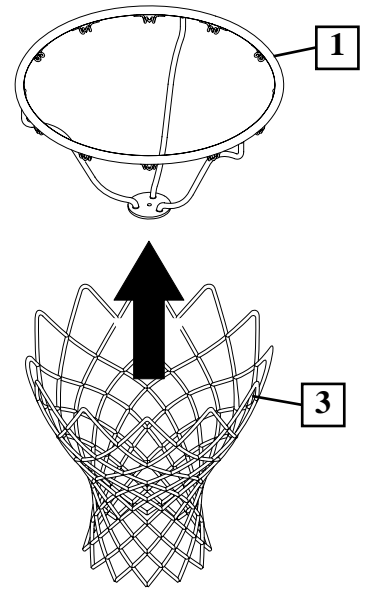

### OUTSIDE VIEW

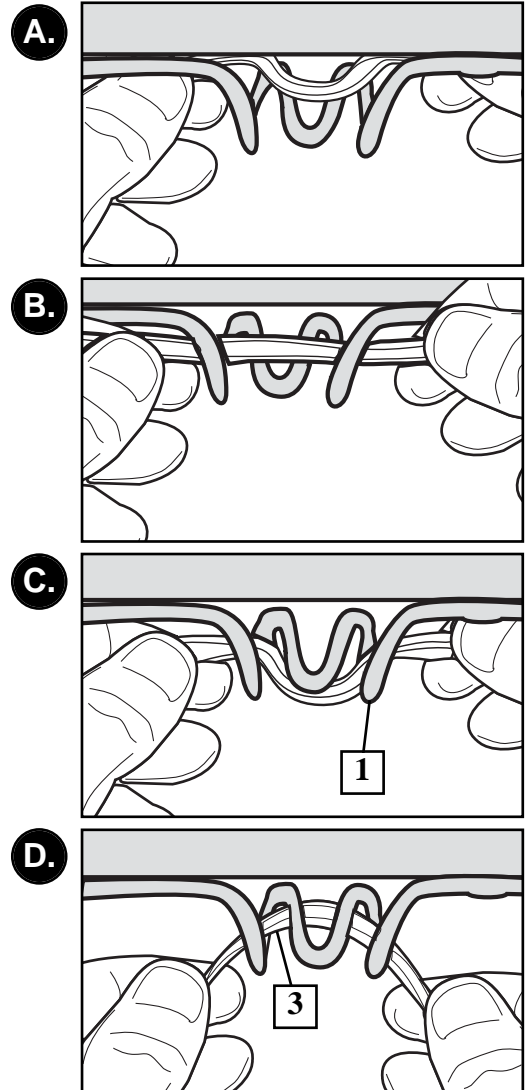

**5.**

Install the rim (1) assembly onto the rod (6) above the pole (9). Secure with washer (7) and acorn nut (11) as shown. Tighten completely.

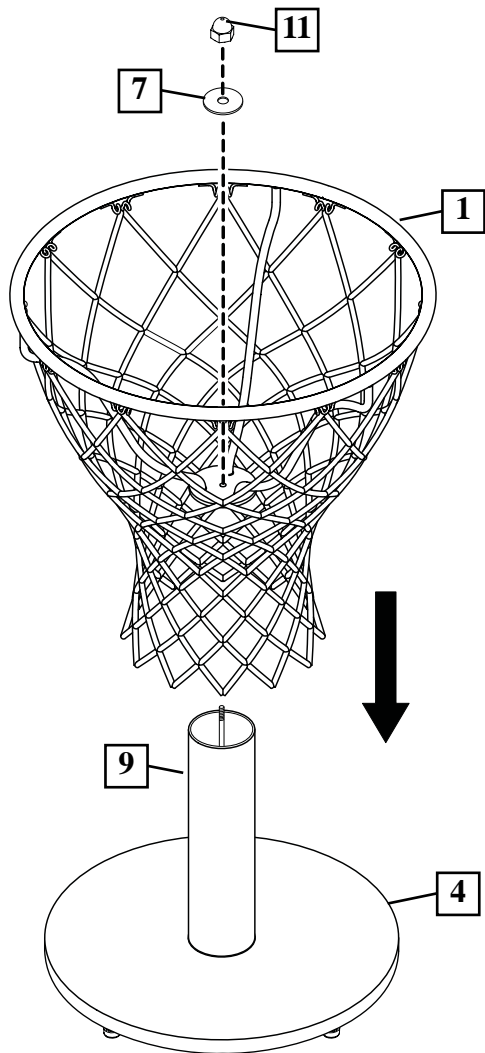

**6.**

Attach the bumpers (12) to the top of the rim (1) surface as shown.

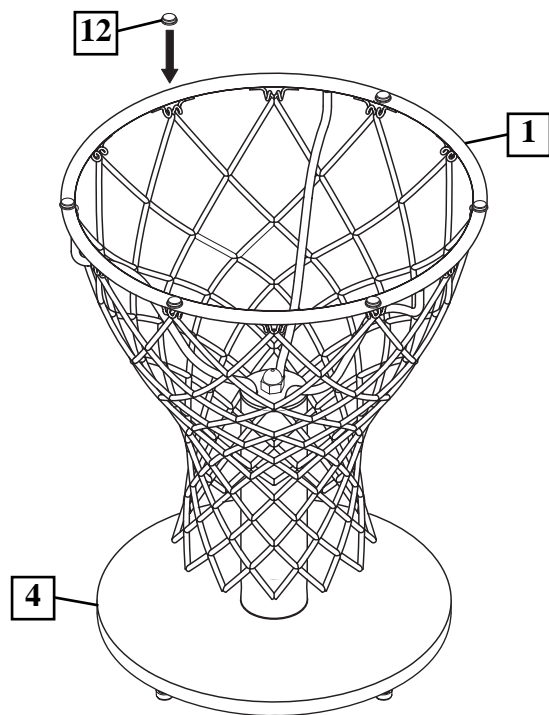

**7.**

Position table top (2) as shown.

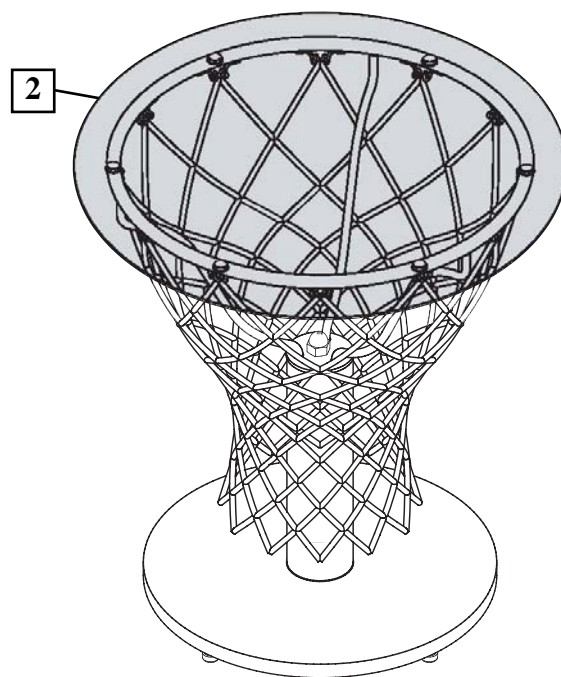

## Free Manuals Download Website

<http://myh66.com>

<http://usermanuals.us>

<http://www.somanuals.com>

<http://www.4manuals.cc>

<http://www.manual-lib.com>

<http://www.404manual.com>

<http://www.luxmanual.com>

<http://aubethermostatmanual.com>

Golf course search by state

<http://golfingnear.com>

Email search by domain

<http://emailbydomain.com>

Auto manuals search

<http://auto.somanuals.com>

TV manuals search

<http://tv.somanuals.com>