

SPECO TECHNOLOGIES CVC-927PTZ DOME CAMERA

Instruction Manual



Please read this manual thoroughly before use and keep it handy for future reference.

Rev.040812

Warnings and Cautions

WARNING

TO REDUCE THE RISK OF FIRE OR ELECTRIC SHOCK, DO NOT EXPOSE THIS PRODUCT TO RAIN OR MOISTURE. DO NOT INSERT ANY METALLIC OBJECTS THROUGH THE VENTILATION GRILLS OR OTHER OPENINGS ON THE EQUIPMENT.

CAUTION

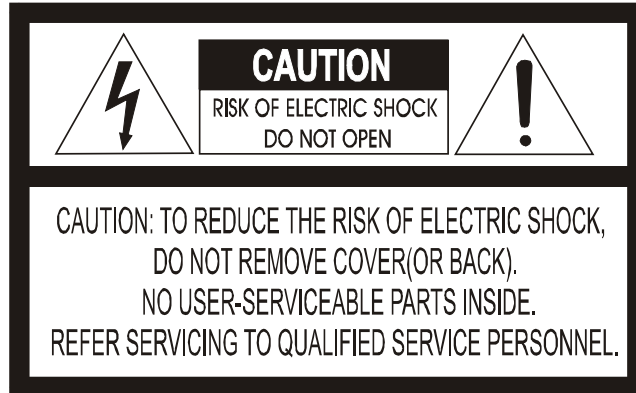

EXPLANATION OF GRAPHICAL SYMBOLS



The lightning flash with arrowhead symbol, within an equilateral triangle, is intended to alert the user to the presence of uninsulated "dangerous voltage" within the product's enclosure that may be of sufficient magnitude to constitute a risk of electric shock to persons.



The exclamation point within an equilateral triangle is intended to alert the user to the presence of important operating and maintenance (servicing) instruction in the literature accompanying the product.

FCC COMPLIANCE STATEMENT

FCC INFORMATION: THIS EQUIPMENT HAS BEEN TESTED AND FOUND TO COMPLY WITH THE LIMITS FOR A CLASS A DIGITAL DEVICE, PURSUANT TO PART 15 OF THE FCC RULES. THESE LIMITS ARE DESIGNED TO PROVIDE REASONABLE PROTECTION AGAINST HARMFUL INTERFERENCE WHEN THE EQUIPMENT IS OPERATED IN A COMMERCIAL ENVIRONMENT. THIS EQUIPMENT GENERATES, USES, AND CAN RADIATE RADIO FREQUENCY ENERGY AND IF NOT INSTALLED AND USED IN ACCORDANCE WITH THE INSTRUCTION MANUAL, MAY CAUSE HARMFUL INTERFERENCE TO RADIO COMMUNICATIONS. OPERATION OF THIS EQUIPMENT IN A RESIDENTIAL AREA IS LIKELY TO CAUSE HARMFUL INTERFERENCE IN WHICH CASE THE USER WILL BE REQUIRED TO CORRECT THE INTERFERENCE AT HIS OWN EXPENSE.

CAUTION: CHANGES OR MODIFICATIONS NOT EXPRESSLY APPROVED BY THE PARTY RESPONSIBLE FOR COMPLIANCE COULD VOID THE USER'S AUTHORITY TO OPERATE THE EQUIPMENT.

THIS CLASS A DIGITAL APPARATUS COMPLIES WITH CANADIAN ICES-003.

CET APPAREIL NUMÉRIQUE DE LA CLASSE A EST CONFORME À LA NORME NMB-003 DU CANADA.

CE COMPLIANCE STATEMENT

WARNING

THIS IS A CLASS A PRODUCT. IN A DOMESTIC ENVIRONMENT THIS PRODUCT MAY CAUSE RADIO INTERFERENCE IN WHICH CASE THE USER MAY BE REQUIRED TO TAKE ADEQUATE MEASURES.

IMPORTANT SAFEGUARDS

1. Read these instructions.
2. Keep these instructions.
3. Heed all warnings.
4. Follow all instructions.
5. Do not use this apparatus near water.
6. Clean only with dry cloth.
7. Do not block any ventilation openings. Install in accordance with the manufacturer's instructions.
8. Do not install near any heat sources such as radiators, heat registers, stoves, or other apparatus (including amplifiers) that product heat.
9. Do not defeat the safety purpose of the polarized or grounding-type plug. A polarized plug has two blades with one wider than the other. A grounding type plug has two blades and a third grounding prong. The wide blade or the third prong are provided for your safety. If the provided plug does not fit into your outlet, consult an electrician for replacement of the obsolete outlet.
10. Protect the power cord from being walked on or pinched particularly at plugs, convenience receptacles, and the point where they exit from the apparatus.
11. Only use attachments/accessories specified by the manufacturer.
12. Unplug this apparatus during lightning storms or when unused for long periods of time.
13. Refer all servicing to qualified service personnel. Servicing is required when the apparatus has been damaged in any way, such as power-supply cord or plug is damaged, liquid has been spilled or objects have fallen into the apparatus, the apparatus has been exposed to rain or moisture, does not operate normally, or has been dropped.
14. CAUTION - THESE SERVICING INSTRUCTIONS ARE FOR USE BY QUALIFIED SERVICE PERSONNEL ONLY. TO REDUCE THE RISK OF ELECTRIC SHOCK DO NOT PERFORM ANY SERVICING OTHER THAN THAT CONTAINED IN THE OPERATING INSTRUCTIONS UNLESS YOU ARE QUALIFIED TO DO SO.
15. Use Certified/Listed Class 2 power supply transformer only.

Table of Contents

Chapter 1 — Introduction	1
1.1 Features.....	1
Chapter 2 — Installation and Configuration	3
2.1 Package Contents	3
2.2 Basic Configuration Of Fastrax II E Dome Camera System	4
2.3 Setting Dome Camera Termination.....	5
2.4 Setting Dome Camera Address(Id).....	7
2.5 Setting Dome Camera Protocol	8
2.6 Connection	9
Connecting to the RS-485	9
Connecting to the Monitor	9
Connecting Alarms	9
Connecting the Power	9
2.7 Getting Started	9
Chapter 3 — Program and Operation	11
3.1 Selecting Dome Camera.....	11
3.2 Accessing On-Screen Menu Utility	11
3.3 How To Control On-Screen Menu Utility	12
3.4 Auto Scan	12
3.5 Preset	14
3.6 Shortcut Preset Program	15

3.7 Tour	15
3.8 Pattern	17
3.9 Alarm.....	18
3.10 Area Title.....	18
3.11 Privacy Zone	19
3.12 Camera –HID2404SXEXXX MODEL	21
Focus Control	21
WB(White Balance) Control.....	22
AE Control	22
Line Lock Control	23
Night Shot Menu.....	23
3.13 Camera –HID2404HCEXXX MODEL.....	24
Focus Control	24
WB(White Balance) Control.....	24
AE Control	25
Line Lock Control	26
Night Shot Menu.....	26
3.14 Dome Setup.....	27
Home Function Setup.....	27
OSD Display Setup.....	28
View Direction	28
Dome OSD Display	28
Area Display	28
View Angle Setup	28
Panning Range.....	29
Flip.....	29
Tilt Over Angle.....	29
Initialize Data.....	30
Origin Offset	30

Dome Reset	30
System Information	30
Appendix A — Specifications	31
Appendix B — Troubleshooting.....	34
Appendix C — Glossary	35
Appendix D — Short Cut Key	38

Chapter 1 — Introduction

1.1 Features

The Fastrax II E dome camera and the Fastrax II Keyboard Controller make up the building blocks for any surveillance/security system. Using multiple Keyboard Controllers and multiple dome cameras, no place is too large for monitoring. Extensible and flexible architecture facilitates remote control functions for a variety of external switching devices such as multiplexers and DVRs.

- Built-in 18x(23x,25x) times optical power zoom camera with True Night Shot function
- 240 Preset positions.
- 8 Tours consist of Preset, Pattern, Auto-Scan and other Tours can be programmed with over 300 functions and Preset location. While moving, each Preset scan can be watched in smooth **Vector Scan** mode.
- 8 Auto Scans including vector scan
- 4 Patterns (240second)
- 8 Privacy zones
- 8 Alarm inputs / 4 Aux outs (NC & NO)
- Variable speed from 0.1°/sec to 90°/sec.
Turbo speed is Max 360°/sec with Ctrl key pressed.
Pan / Tilt speed is inversely proportional to the zoom ratio.
Maximum speed is 380°/sec when preset command.
- Programmable user preferences (alarm, preset, title, etc.).
- Up to 999 selectable camera addresses (Optional 3999 : HID2404CE/CZ/CL ONLY)
- Built-in RS-485/422 receiver driver.
- Built-in power-line surge protection and lightning protection
- Clear bubble with black liner (shelter) for concealing the camera.
- Optional Tinted Bubble, Indoor & Outdoor pendant housing with heater & blower, Indoor Flush Mount, Parapet mount & Roof Top mount.

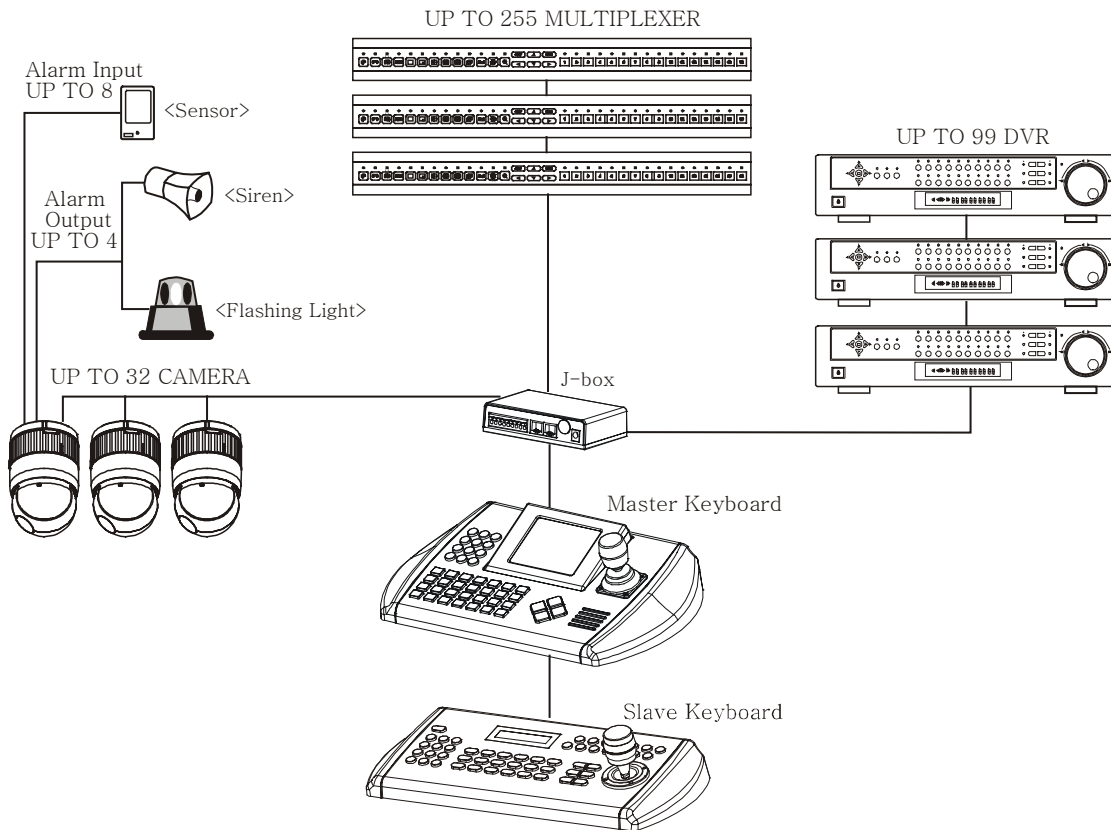

Figure 1 – Typical System Configuration

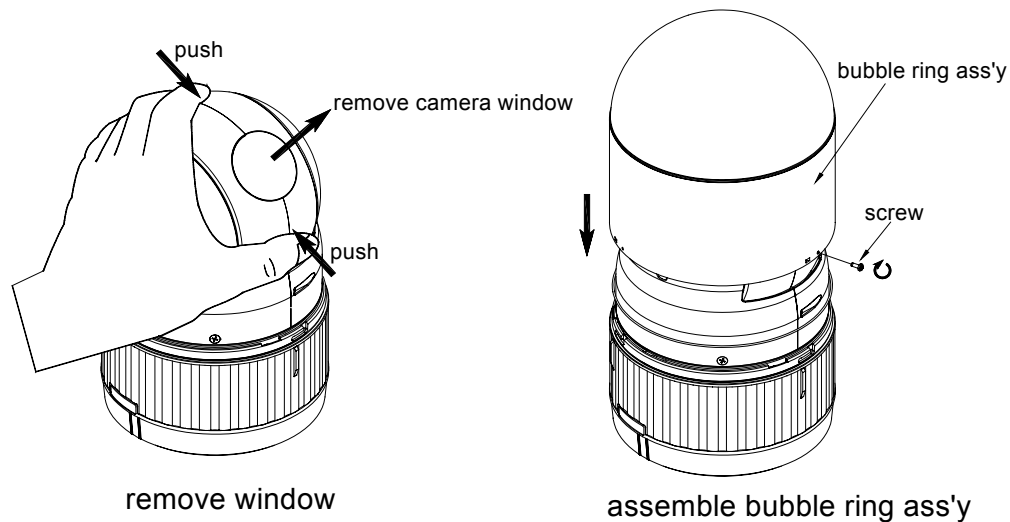

Figure 2 – Assemble bubble ring ass'y

Note : It is recommended to remove camera window for improving picture quality when you use bubble ring ass'y.

Chapter 2 — Installation and Configuration

2.1 Package Contents

The package contains the following.

Fastrax II E (Dome Camera)1
Bubble Ring1
Instruction Manual (This Document)1
Assembly Screws for Attaching Fastrax II E3
Plastic Anchor3
10Pin Connector1
12Pin Connector2

CAUTION: Be sure to have caution labels(E version only) on both the body and the base of the camera. Different version will not support input and output.

The dome camera is for use in surface mounting applications and the mounting surface should be capable of supporting loads up to 10lb (4.5 kg).

The dome camera's base should be attached to a structural object, such as hard wood, wall stud or ceiling rafter that supports the weight of the dome camera.

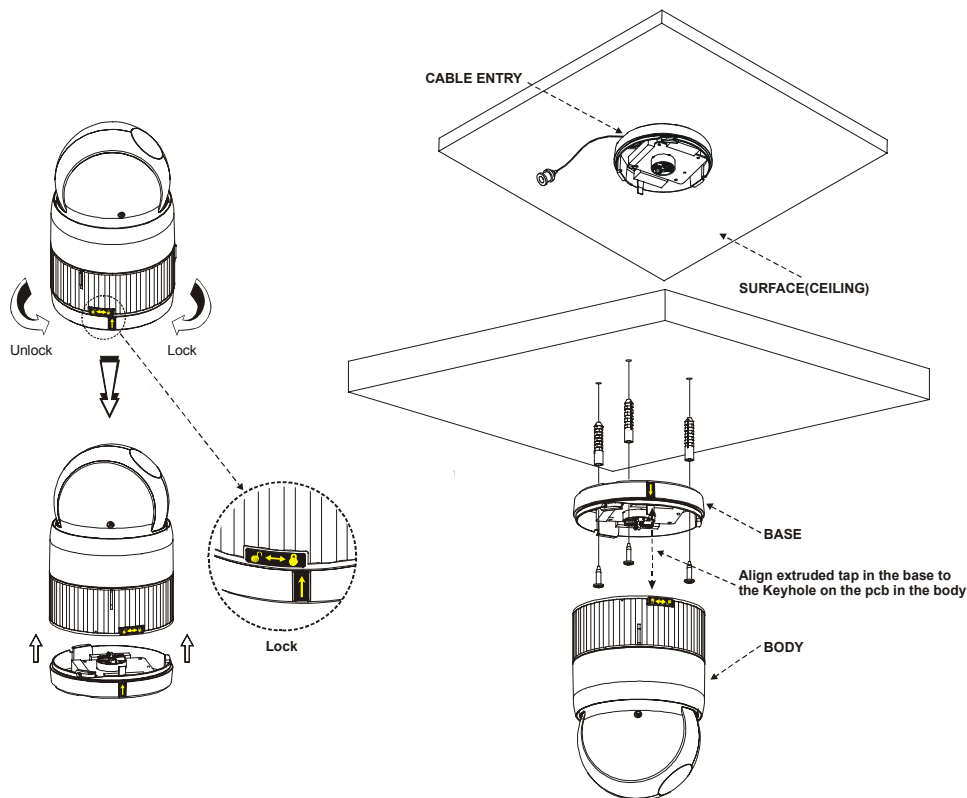

Figure 3 – Installation

2.2 Basic Configuration of Fastrax II E Dome Camera System.

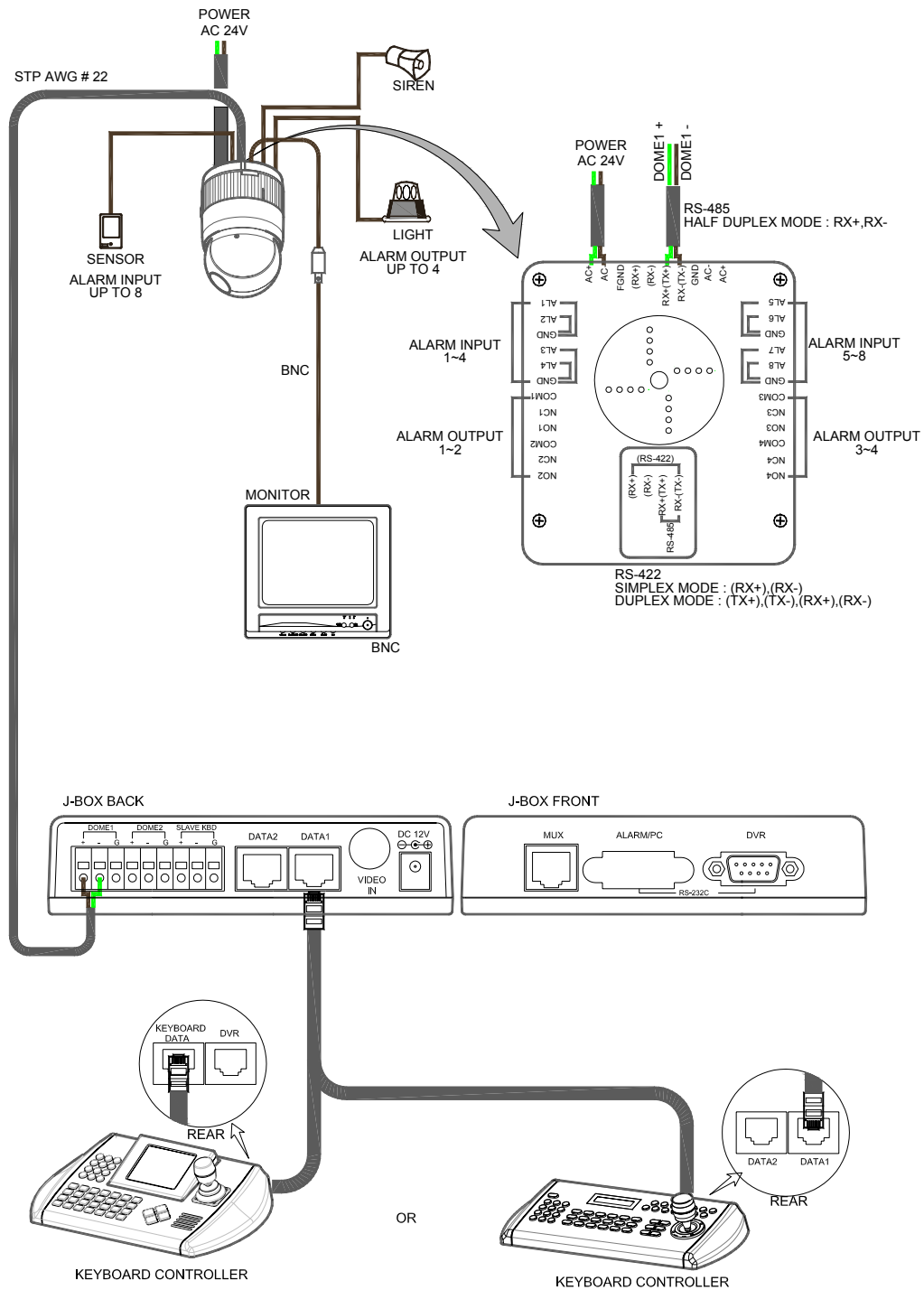

Figure 4– Basic installation diagram

The dome camera must be installed by qualified service personnel in accordance with all local and federal electrical and building codes. The system should be installed according to Figures 4 through 9.

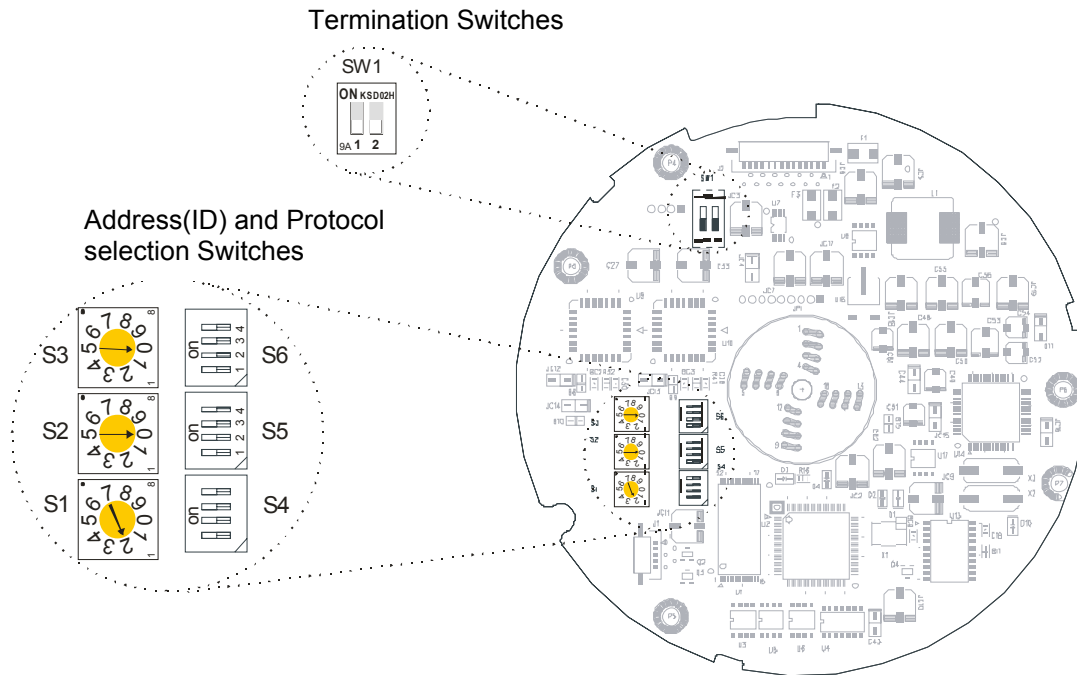

Figure 5– Layout of Switches

2.3 Setting Dome Camera Termination

The device which is connected at end of line, whether it be a dome camera or keyboard controller, must have the cable for communication terminated by setting the appropriate DIP switch. Without proper termination, there is potential for control signal errors. Total length of the cable for communication should not exceed 1.2Km.

SW1

SW1	1	2
Terminated	ON	ON
Not terminated	OFF	OFF

Figure 6– Setting Dome Camera Termination

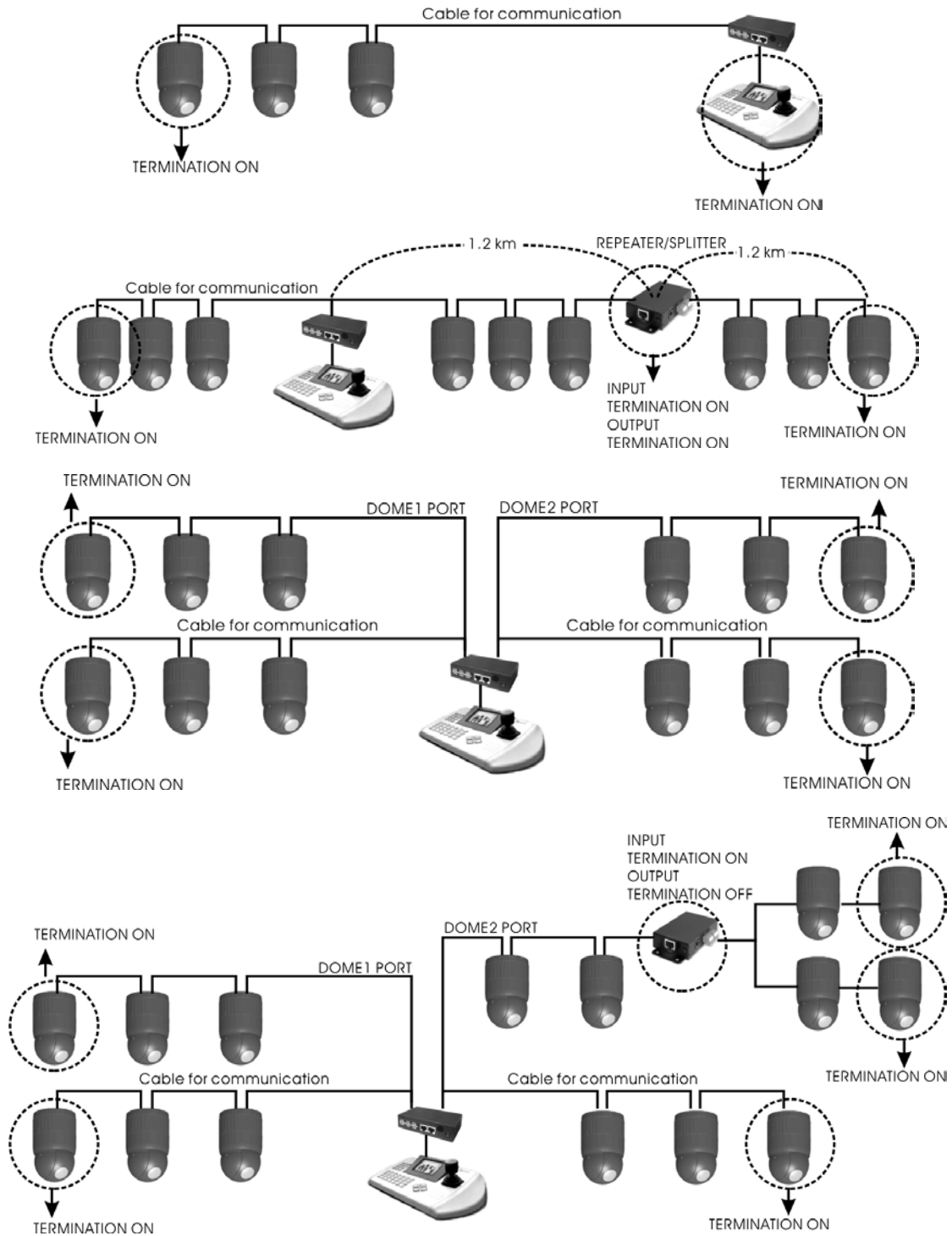

Figure 7- Termination Diagram

2.4 Setting Dome Camera Address (ID)

To prevent damage, each dome camera must have a unique address (ID). When installing multiple dome cameras using a multiplexer, it is suggested that the dome camera address match the multiplexer port number.

If you want to set the address more than 999, you should contact the service provider.

Example: Port 1 = Dome 1, Port 2 = Dome 2 ... Port 16 = Dome 16. If more than 16 dome cameras are installed using two or more multiplexers, ID of the dome camera should be ID of MUX x No. of camera IN. (e.g. multiplexer ID= n, Camera IN= m then ID of Dome = $16x(n-1)+m$)

Refer to Figures 4-5 for setting the dome camera address (ID) and protocol selection.

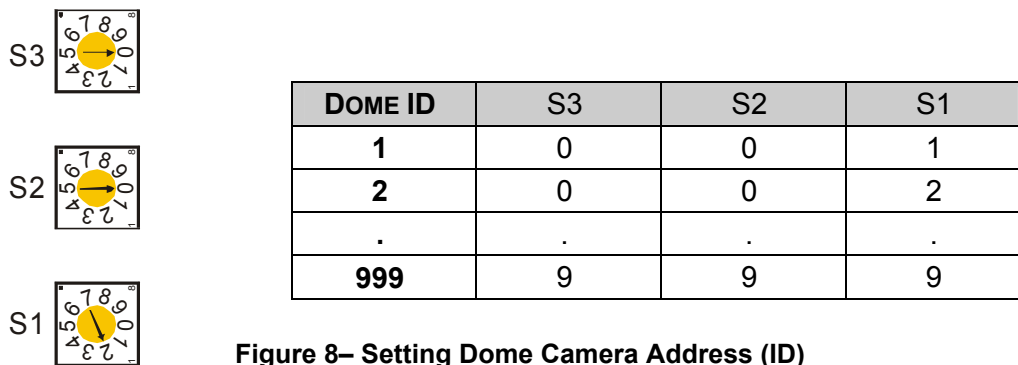
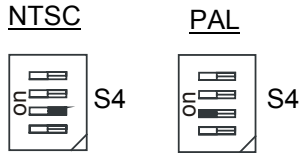

Figure 8– Setting Dome Camera Address (ID)

2.5 Setting Dome Camera Protocol

If a dome camera is to be installed with a Fastrax keyboard controller, select F2 protocol.

Consult service personnel if a dome camera is installed with device other than a keyboard controller.



S/W		On	Off	FUNCTION
D1	S4-1	Enable	Disable	Alarm
D2	S4-2	PAL	NTSC	NTSC/PAL
D3	S4-3			Reserved
D4	S4-4	RS-422	RS-485	RS-422/RS-485

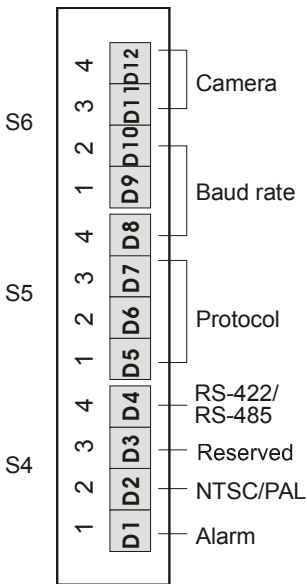

D5	D6	D7	PROTOCOL
S5-1	S5-2	S5-3	
Off	Off	Off	F2,F2E,P,D,E & Ph Protocol (Default)
Off	Off	On	Reserved
Off	On	Off	S 422
Off	On	On	Reserved
On	Off	Off	V Protocol
On	Off	On	Reserved
On	On	Off	D Color
On	On	On	Reserved

D8	D9	D10	BAUD RATE
S5-4	S6-1	S6-2	
Off	Off	Off	2400 bps
Off	Off	On	4800 bps
Off	On	Off	9600 bps (Default)
Off	On	On	19200 bps
On	Off	Off	38400 bps
On	Off	On	57600 bps
On	On	Off	115200 bps
On	On	On	230400 bps

D11	D12	CAMERA
S6-3	S6-4	
Off	Off	Default cameras (Default)
Off	On	Reserved
On	Off	Reserved
On	On	Reserved

Figure 9– Protocol Selection Switches

2.6 Connections

• Connecting to the RS485/ 422

The dome camera can be controlled remotely by an external device or control system, such as a control keyboard, using RS485 half-duplex , RS422 duplex or simplex serial communications signals. Connect Marked Rx+, Rx- to Tx+ and Tx- of the RS485 control system.

If control system is RS422, connect Rx+(Tx+), Rx+(Tx-) and Rx+, Rx- of the dome camera to Tx+, Tx- and Rx+, Rx- of the control device respectively.

• Connecting Video out connector

Connect the video out(BNC) connector to the monitor or video input.

• Connecting Alarms

AL1 to 8 (Alarm In)

You can use external devices to signal the dome camera to react on events. Mechanical or electrical switches can be wired to the AL (Alarm In) and GND (Ground) connectors.. See Chapter 3 — Program and Operation for configuring alarm input.

GND (Ground)

NOTE: All the connectors marked GND are common.

Connect the ground side of the Alarm input and/or alarm output to the GND connector.

NC(NO)1 TO 4 (Normal Close or Normal Open : Alarm Out)

The dome camera can activate external devices such as buzzers or lights. Connect the device to the NC(NO) (Alarm Out) and COM (Common) connectors. See Chapter 3 — Program and Operation for configuring alarm output.

• Connecting the Power

Connect the power of AC 24V 850mA to the dome camera.

Use certified / Listed Class 2 power supply transformer only.

2.7 Getting Started

Once installed apply power to the dome camera. The dome camera will start a configuration sequence. When configuration is done, the following information is displayed on the keyboard controller's LCD

RAM TEST
 CHECK NO. : OK!
 CHECK AAAA : OK!
 CHECK 5555 : OK!



FASTRAX II E Vx.xxx
 CAMERA TYPE xxxx
 WAIT DOME SETTING.
 INIT TILT ORGIN SET OK
 INIT PAN ORGIN SET OK
 INIT CAMERA SET OK

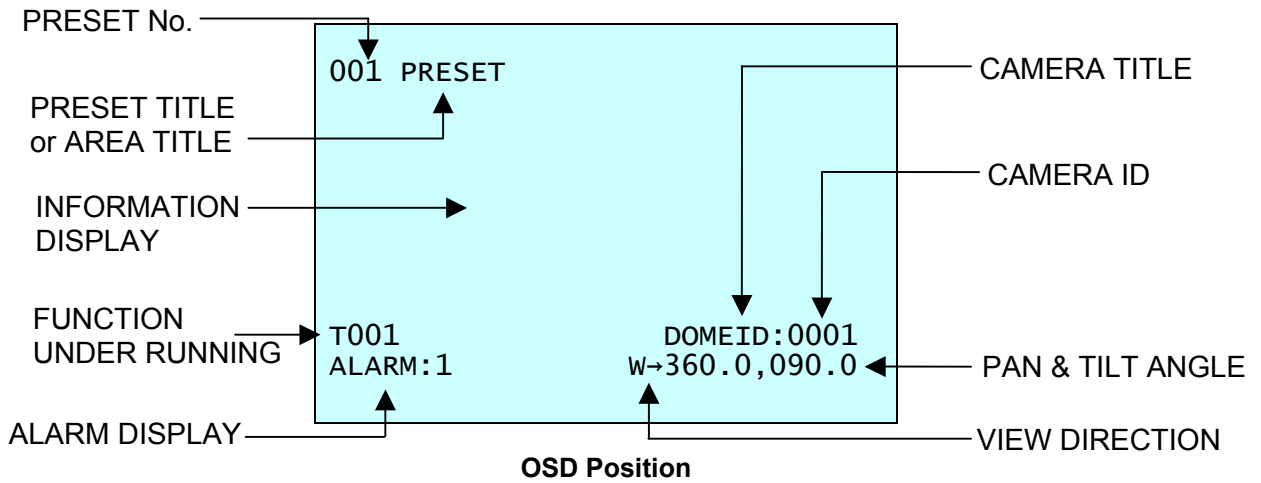

Chapter 3 — Program and Operation

3.1 Dome Camera Selection

Before you program or operate a dome camera, you must select the dome camera by pressing the dome camera **No.** + **CAM**

Example: Pressing **1**, **0** and **CAM** key sequentially will select dome camera 10. The selected dome camera ID will be displayed on the LCD monitor of the keyboard controller.

3.2 Accessing the On-Screen Menu Utility

You can call up the On-screen menu utility on your monitor by pressing **MENU** key on the keyboard controller, the following On-screen menu utility will appear:

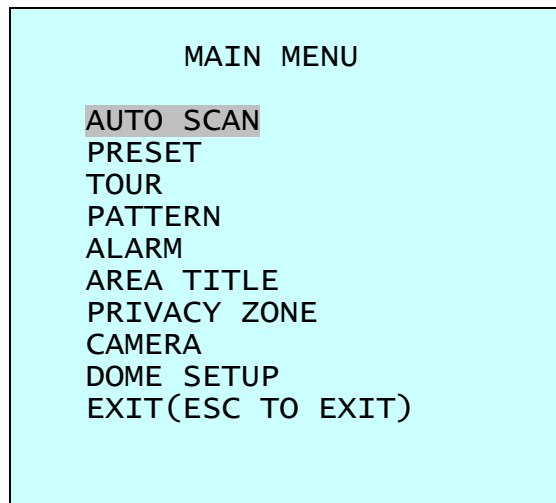

3.3 How to control the On-Screen Menu Utility

Action	Function
MENU	Call the On-screen menu utility
Joystick left or right	Go into the sub-menu items. Execute the command(exit) Change value. Navigate through the menu items.
Joystick up or down	Navigate through the menu items.
Joystick down	Finish editing title.
Zoom handle twist	Change value. Enter editing title mode.
CTRL + Joystick	Change value of angle
ESC	Escape (EXIT)

3.4 Auto Scan (First Item of the Main menu / Shortcut: **SCAN**)

The Auto scan supports up to 8 programmed angles at user-programmable speeds. Follow these steps to program Auto Scan:

```

AUTO SCAN SETUP

SCAN 01      : AUTOSCAN01
SPEED(MODE) : FAST VECTOR
START ANGLE  : 127.1, 027.7 X7
END ANGLE    : 157.7, 080.7 X13
SCAN DIR.    : CCW
SWAP         : OFF
SAVE AND EXIT (ESC TO CANCEL)

HOLD DOWN CTRL KEY
WHILE SELECT POSITION.
    
```

SPEED(MODE) : NORMAL1~NOMAL9,SLOW VECTOR,FAST VECTOR
 NORMAL1 (SLOWER) ↔ NORMAL9 (FASTER)
 SLOW VECTOR, FAST VECTOR : Move from start point to end point including tilt and zoom simultaneously and linearly. In case of HID2404HCExxx model, zoom is fixed at more wide angle and the zoom magnification information is not displayed.

1. Press the **SCAN** key to enter Auto Scan menu directly. Or press the **MENU** key to display the main menu on the monitor. Scroll to Auto Scan and push the **Joystick** to the right.
2. Select an Auto Scan number by pushing the **Joystick** left or right.
3. Twist the **Joystick** to enter the title by scrolling through the alphanumeric characters and pushing the handle to the right or left to move to the next space. Press **ENTR** key or push the **Joystick** down to finish title mode.
4. When finish entering the title, select "START ANGLE" with the **Joystick**. Hold down the **CTRL/PGM** key while selecting the start position using the **Joystick**. Current panning position will be displayed. Release **CTRL/PGM** key to complete the selection of the start position.
5. Push the **Joystick** downward to select "END ANGLE." Hold down the **CTRL/PGM** key while moving the Joystick to select the end position. The end position angle should be larger than start position. Release the **CTRL/PGM** key to complete the selection of the end position.
6. Push the **Joystick** downward to select "Tilt & Zoom." Set the zoom and tilt angle by holding down the **CTRL/PGM** key.
7. Push the **Joystick** downward to select "Speed" and set the speed by twisting the **Joystick** clockwise or counterclockwise (HID2404CZ) or moving the **Joystick** left and right(HID2404CL) to select the auto scan speed.
8. Select Save and Exit by pushing the **Joystick** to the right. Press **ESC** to exit the program without saving.

Pressing the **HOME** key delete stored data and display 000 angle immediately.

NOTE: Using the Tour mode in conjunction with preset and Auto Scan, you can make the camera travel from one preset position to another preset position at a specific speed. (Pan only)

- a. Before entering the Auto Scan menu, select a preset position as a starting point for Auto Scan.

Example: **2** + **PRST** and do step 1 to 4. Instead of step 5, just press the **Ctrl/PGM** key at the start angle position, the current position will be displayed as a start position.

- b. Save and exit from the menu.

- c. In normal mode, call a preset to be the end point of scan. Press **3** + **PRST** then press **Scan** key to enter the Auto Scan menu. Move the cursor position to END ANGLE. Just press **CTRL/PGM** key at the end angle position. Do steps 7 to 9.

Example: Preset 001>002>003>004>005>006, Auto Scan 01 starts at 002, ends at 003, Auto Scan 02 starts at 005, ends at 006. Tour 001, 002, A01, 004, A02.

1 → 2 2~3 → 4 → 5~6 → 1 → 2 2~3

Where → : Quick move, ~ : Programmed speed by Auto Scan.

3.5 Preset (Second Item of the Main menu / Shortcut: **PRST**)

If you need to view specific places routinely, you should program presets. A preset is a programmed video scene with automatic pan, tilt, zoom, focus and iris settings. Once programmed, entering the number and pressing a **Preset** button on your controller automatically calls up the preset. In addition, presets may be assigned to alarm actions or as the “home” position for the dome camera. As many as 240 presets, whose positions are saved in the dome’s firmware, may be programmed.

There are three pages of preset menu, each page can hold 80 presets. Pages can be scrolled by pushing the **Joystick** to the Left or Right on the first or last No. of Preset.

```
PRESET SETUP
NO. 001: xxxxxxxxxxxxxxxxxx
FOCUS  : AUTO (MANUAL)
IRIS   : AUTO (MANUAL)
DWELL  : 03 SEC(0~99)

 1234567890 1234567890
00■***=====01=====
02=====03=====
04=====05=====
06=====07=====
JOY-LEFT TO PREV. PAGE
SAVE AND EXIT(ESC TO CANCEL)
```

- x : 16 digits of title for preset label
- = : blank preset position
- * : position has the preset
- : Current cursor position

Follow steps below to store the Preset positions:

1. Press **MENU** to display the main menu. Select the Preset option by using the **Joystick** to the right. (Press Prst to go directly to the Preset menu without going through the main menu.)
2. Select the blank preset position to be stored by pushing the **Joystick** up, down, right, or left.
3. The position, which is marked with ★ , already has the preset view assigned. To review the stored preset, press Prst key on the ★ , The camera will show the stored preset view.
4. After selecting a blank position, press and hold **CTRL/PGM**, Use the **Joystick** to control the direction of the camera and lens.

5. After aiming the camera (view direction and lens control), release **CTRL/PGM**. Then twist the **Joystick** handle or Press **Tele** or **Wide** Key to store the selected view. The position number will be displayed and the user will be prompted to enter a preset title.
6. Enter the title for the preset position using the **Joystick**. (Rotate handle clockwise and counterclockwise or press **Tele** or **Wide** Key to scroll through the alphanumeric characters, push the handle to right or left to select next or previous digit.)
7. When you are finished entering the title, push the **Joystick** downward. Set the focus by pushing the **Joystick** to the right or left. Set the IRIS value in the same manner as the focus.
8. Move to the DWELL setting by pushing the **Joystick** down. Twist the **Joystick** clockwise or counterclockwise to increase or decrease dwell time of the preset position.
9. To select the next page of presets, scroll the page by pushing the **Joystick** to the Left on the first and last columns of the menu.
10. Repeat steps 2 through 7 for each additional preset position.
11. To edit the title of a stored preset, use the **Joystick** to position the cursor on the desired preset position. Press the Prst key to recall the stored preset. Twist the zoom handle clockwise to enter the preset title, focus and IRIS. Preset titles are useful with short cut preset programming. Refer to Shortcut programming below.
12. Select Save and Exit by pushing the Joystick to the right. Press ESC to exit the Preset menu without saving.

NOTE: Press the Home key at programmed position to delete a programmed preset view.

3.6 Shortcut of Preset Program.

Select a view to be stored (direction of the camera, zoom and focus), then press No. (1 to 240), and then press **PGM**, **PRST** subsequently. The current view will be stored to the selected preset number if position is empty. If selected preset number is not empty, "PRESET EXISTING" message will be displayed on the monitor and be prompted to overwrite.

Example: **1**, **0**, **1** + **PGM** + **PRST** will store current view as preset No. **101**. In this case, focus and Iris mode will be programmed as Auto, dwell time will be set to 3 sec.

3.7 Tour (THIRD ITEM OF THE MAIN MENU / SHORTCUT: **TOUR**)

There are 8 programmable Tours. Each Tour consists of up to 42 Preset positions, Patterns, Scans or other Tours (second-level). Using second-level Tours, it can be expanded to over 300 functions in a single Tour. However second level Tours will be ignored when called by a Tours. The following example illustrates this concept:

If Tour1 has Preset1 → Preset2 → Tour2 → Tour3 and
 Tour2 has Preset3 → Preset4 → Tour4 → Preset5 and
 Tour3 has Preset6 → Pattern 1 and
 Tour4 has Preset7.

Tour1 executes as follows:

Preset1 → Preset2 → Preset3 → Preset4 → Preset5 → Preset6 → Pattern1 →
 Preset1 → ... (Repeat)

Tour2 executes as follows:
 Preset3 → Preset4 → Preset7 → Preset5 → Preset1 ... Repeat
 (Tour4 is still valid if called directly from Tour2.)

```

TOUR 01:xxxxxxxxxxxxxxxxxxx
SCAN TYPE:NORMAL

=== === 003 === === ===
A08 === === === ===
=== T02 === 001 === ===
=== === T08 === ===
=== === === ===
=== === === ===
SAVE AND EXIT(ESC TO CANCEL)
PRESS FUNCTION KEY AND ROTATE
JOYSTICK TO SELECT NUMBER.
  
```

xxxxx	: 16 digits of title for tour label
===	: blank preset position
SCAN TYPE	: Max (Normal)/ Slow V. Scan/ Fast V. Scan
DWELL	: 03-99 Sec
003	: Preset 003 (1~240)
A08	: Auto Scan 08 (1~8)
P01	: Pattern 01 (1~4)
T02	: Tour 02 (1~8)

Follow the steps below to program the Tours:

1. Press **MENU** to display the main menu on the monitor. Scroll to Tour and push the **Joystick** to the right to enter the Tour menu. Or just press the Tour key on the keyboard
2. Choose an empty location to be programmed by pushing the **Joystick** up, down, right, or left.
3. To see a stored preset view, use the **Joystick** to move the cursor to a stored position. By pressing Prst key, the camera will move to the stored Preset view.
4. To add a stored preset as a Tour, twist the Zoom handle or press Zoom Key (Programmed preset will scroll). To remove a stored preset from the Tour, press the Home key, blank position mark (===) will be displayed. You can overwrite the programmed position.
5. To place functions other than preset, press Tour, Ptrn, or Scan for Tour, Pattern or Auto Scan respectively.
6. Repeat Step 2 through 5 for each desired position. Each title will be displayed on top of the line.
7. Up to 36 Presets, Tours, Patterns Scans can be selected for a Tour. You can expand the Tour sequence by calling other programmed tours. Push the **Joystick** handle to right or left while the cursor is on the top of the line (TOUR 01) to select another page of the Tour menu. (TOUR 01)
8. You can enter a title for the selected Tour by twisting the **Joystick** while the cursor is on the top of the line (TOUR 01). Rotate the handle clockwise or counterclockwise to scroll

through the alphanumeric characters. Push the handle to the right or left to select the next or previous digit.

9. Select Save and Exit by pushing the **Joystick** to the right. Press **ESC** to exit the program without saving.

NOTE: Press the Home key at a programmed position to delete programmed function. In the Tour mode, in conjunction with preset and Auto Scan, you can make the camera travel from a preset position to another preset position at a specific speed.

Example: Preset 001>002>003>004>005>006, Auto Scan 01 starts at preset 002, ends at preset 003, Auto Scan 02 starts at preset 005, ends at preset 006; Tour 001, 002, A01, 004, A02.

1 → 2 2~3 → 4 → 5~6, repeat
where → : Quick move, ~ : Programmed speed

3.8 Pattern (Fourth 4 Item of the Main menu / Shortcut: **PTRN**)

The Pattern feature records user control of the selected dome camera for up to 240 seconds. Up to four 4 patterns can be stored and played back by pressing No.+ **PTRN** keys subsequently.

PATTERN SETUP		
NO.	TITLE	SEC
01	: xxxxxxxxxxxxxxxxxxxx	000
02	: xxxxxxxxxxxxxxxxxxxx	041
03	: xxxxxxxxxxxxxxxxxxxx	010
04	: xxxxxxxxxxxxxxxxxxxx	020
TOTAL		071
SAVE AND EXIT(ESC TO CANCEL)		
HOLD DOWN CTRL KEY WHILE RECORDING.		

Follow steps below to program the Pattern:

1. Press **MENU** key to display the main menu on the monitor.
2. Scroll down to **PATTERN** and push the **Joystick** to the right. Or simply press the **PTRN** key rather than use the Main Menu.
3. Select the empty Pattern number to be programmed by pushing the **Joystick** Up or Down. If last column is not 000, a pattern has already been recorded. Patterns can be over written.
4. Press and hold down the **CTRL/PGM** key while controlling the camera direction and zoom with the **Joystick**. Your controls will be automatically recorded until you release the **CTRL/PGM** key. You can repeat this procedure until you have the pattern you want. Previously recorded patterns will be overwritten each time you do this.
5. Scroll down to the Save and Exit option and push the **Joystick** to the right to save and exit.
6. You can title the selected Pattern by twisting the **Joystick**. Rotate the handle clockwise or counterclockwise to scroll through the alphanumeric characters, push the handle to right or left to select next or previous space.

7. Pressing **ESC** will not save your information and exits to the previous mode.

Press the **HOME** key at any programmed position to delete that programmed pattern.

NOTE: If total recording time reaches 240 seconds, it will automatically stop for a moment and restart recording. Previous data will be overwritten.

3.9 Alarm (This menu shows on only specific model, Fifth Item of Main menu)

ALARM SETUP						
NO	PRI	PRS	IN	OUT	HLD	LATCH
01	1	001	OFF	OFF	3	OFF
02	0	A01	OFF	OUT1	3	OFF
03	1	240	NO	OUT1	3	OFF
04	2	001	NC	OUT4	3	OFF
05	1	001	OFF	OFF	3	OFF
06	8	001	OFF	OUT1	3	OFF
07	1	240	NO	OUT1	3	OFF
08	2	001	NC	OUT4	3	OFF
SAVE AND EXIT(ESC TO CANCEL)						

NO : Alarm input number

PRI : Lower No. has higher priority, Equal priority alarms will be serviced repeatedly.

PRS : Stored preset number to be called by alarm.

IN : NO/NC - normally open /Closed OFF - ignore

OUT : OUT1~OUT4 - Relay out 1,2,3,4, OFF - No output.

HOLD : Alarm will be held for programmed time (01 to 99 seconds)

LATCH : ON - Shows all alarms including past alarm, OFF - Shows activated alarms only.

There are 8 levels of priority. "0" is the highest priority and can be choosed Autoscan, Pattern or Tour. During responding "0" priority alarm, other alarms won't be serviced until the "0" priority action is completed.

1. Press Menu to display the main menu on the monitor. Select the Alarm option by pushing the **Joystick** up or down and push to right to enter the detail menu.
2. Select the alarm input number by pushing the **Joystick** up or down and select the column you wish to setup. Selected position will be highlighted.
3. Select the Preset, Status of Input (NC/NO/OFF), and Output (OUT1~4/OFF) by pushing the Joystick to the right or to the left.
4. To increase or decrease the preset number or to change the status or output number, twist the **Joystick** clockwise or counterclockwise. In case of preset, programmed preset number will be scrolled.
5. Select the Save and Exit option by pushing the **Joystick** up or down. Save and exit the program by pushing the **Joystick** to the right. Press **ESC** to exit the program without saving.

3.10 Area Title (Sixth Item of Main menu)

Enter a specific name on programmed angle between START and END. For the screen below, when the camera points at an angle between 124.3° to 359.5°, ABC will be displayed on the screen.

NO	AREA TITLE SETUP	
	TITLE	START END
01	ABC	124.3 359.5
02	XXXXXXXXXXXXXXXXXX	=====
03	XXXXXXXXXXXXXXXXXX	=====
04	XXXXXXXXXXXXXXXXXX	=====
05	XXXXXXXXXXXXXXXXXX	=====
06	XXXXXXXXXXXXXXXXXX	=====
07	XXXXXXXXXXXXXXXXXX	=====
08	XXXXXXXXXXXXXXXXXX	=====

SAVE AND EXIT(ESC TO CANCEL)
HOLD DOWN CTRL KEY TO MOVE
PAINNING AND SET AREA ANGLE.

Pages can be scrolled through by pushing the **Joystick** to the Left or Right on the first or last column of the menu. Pushing the **Joystick** to left on the “NO” column (01 ~ 08) of the menu to scroll to the previous page. Push the **Joystick** to right on the “END” column to go to the next page.

1. Press **MENU** to display the main menu on the monitor. Select the Area Title option by pushing the **Joystick** up or down and push to right to enter the detail menu.
2. Select the area number by pushing the **Joystick** up or down. Select Start, End or number column to be set by pushing the handle to the right or left. The selected column will be highlighted.
3. To enter area title, select the number column and rotate the handle clockwise or counterclockwise. You can select alphanumeric characters by rotating the handle. Move to the next character by pushing the **Joystick** to the right. To finish entering the title, push the **Joystick** down.
4. To adjust panning limit, press the **CTRL/PGM** key and hold down. Then use the **Joystick** to go the desired direction. The end limit must be in an increasing direction. (Start < End).
5. When you press the **CTRL/PGM** key, the current position of the pan will be printed in the highlighted column. With this feature, you can easily set the next start point as the previous end point.
6. Select the Save and Exit option by pushing the **Joystick** up or down. Save and exit the program by pushing the **Joystick** to the right. Press ESC to exit the program without saving.

Pressing the **HOME** key will delete programmed data. (Angles will be turned ==== immediately.)

3.11 Privacy Zone (Seventh Item of Main menu)

Hide up to 8 unwanted views in a camera.

PRIVACY ZONE SETUP			
NO	TITLE	METHOD	
01	XXXXXXXXXXXXXXXXXX	ON	BLOCK
02	XXXXXXXXXXXXXXXXXX	OFF	V.OFF
03	XXXXXXXXXXXXXXXXXX	NONE	====
04	XXXXXXXXXXXXXXXXXX	NONE	====
05	XXXXXXXXXXXXXXXXXX	NONE	====
06	XXXXXXXXXXXXXXXXXX	NONE	====
07	XXXXXXXXXXXXXXXXXX	NONE	====
08	XXXXXXXXXXXXXXXXXX	NONE	====
SAVE AND EXIT(ESC TO CANCEL)			

1. Press **MENU** to display the main menu on the monitor. Select the Privacy Zone option by pushing **Joystick** Up or Down and push to right to enter the detail menu.
2. Select the privacy zone number by pushing the Joystick up or down.
3. To enter the zone name, rotate the handle clockwise or counterclockwise. You can select alphanumeric characters by rotating the handle. Move to the next character position by pushing the Joystick to the right. To finish entering the title, push the **Joystick** down or press the **ENTR** key.
4. To adjust the "marked" (privacy) area, press and hold down the **CTRL/PGM** key and then use the **Joystick** (direction and zoom) until you get desired view. Release the key, the right column will be set to ON.
5. You can overwrite an existing zone. Use the Home key to delete the marked zone, or push the **Joystick** to the right or left to turn the stored zone On or Off.
6. Select the Save and Exit option by pushing the **Joystick** up or down. Save and exit the program by pushing the **Joystick** to the right. Press **ESC** to exit the program without saving.

Press the **HOME** key to delete programmed privacy zone.

3.12 Camera (Eighth Item of Main menu) – HID2404SxExxx MODEL

NOTE: The menu features will vary depending on the camera module installed in your dome camera.

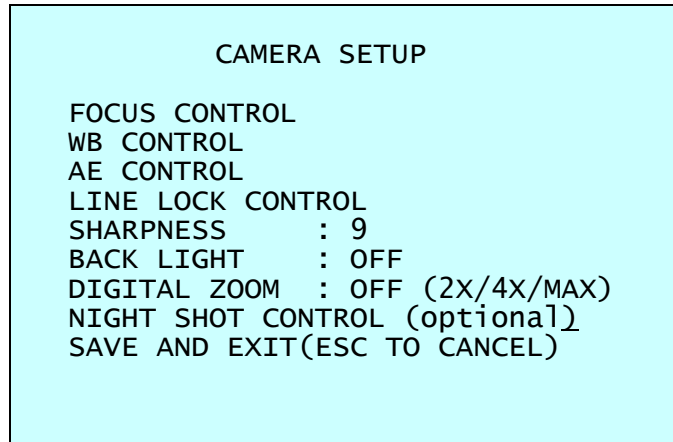

SHARPNESS
BACK LIGHT
Digital ZOOM

The higher the value, the more edges in the picture will be enhanced(0~15)
Objects in front of bright backgrounds will be clearer with BLC ON.
OFF : Zoom range is limited to the optical.
2x : Zoom is extendable up to 2x of digital range.
4x : Zoom is extendable up to 4x of digital range.
MAX: Zoom is extendable Max digital zoom range.

•**FOCUS CONTROL**

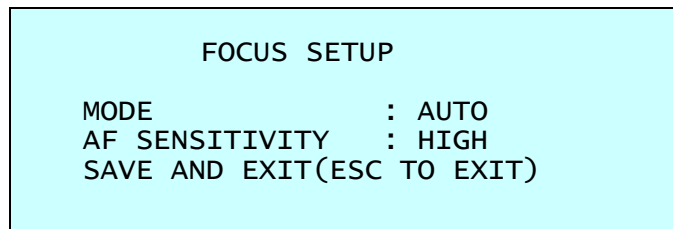

MODE : AUTO / MANUAL

Use manual mode in normal use.

AF SENSITIVITY : HIGH / LOW

HIGH: Use this option when shooting fast motion.

LOW: Offers better focus stability. In low luminance conditions, Auto Focus stops operation even when brightness changes, enabling stable images of moving objects.

CAUTION: Avoid continuous, 24-hour use of the auto focus. This will shorten the lifespan of the lens.

• WB (white balance) CONTROL

```
WB SETUP

MODE      :      AUTO
R GAIN    :      210
B GAIN    :      155
EXIT(ESC TO EXIT)
```

MODE MANUAL / AUTO / INDOOR / OUTDOOR / ONE PUSH / ATW
RGAIN 0 ~ 255
BGAIN 0 ~ 255

Use the ATW mode for normal use.

RGAIN / BGAIN modes are controllable only in MANUAL Mode

Push the **Joystick** to the right or left to change.

NOTE : “ONE PUSH” means that when rotating the **Joystick** handle for a moment the lens moves to adjust the focus for the subject. The focus lens then holds that position until the **Joystick** handle rotation.

• AE CONTROL

```
AE SETUP

MODE      : FULL AUTO
SLOW SHUTTER : AUTO
IRIS      : F2.4
GAIN      : 0 DB
BRIGHT    : 14
SHUTTER   : 1/60
SAVE AND EXIT(ESC TO CANCEL)
```

MODE FULL AUTO / MANUAL / SHUTTER PRIO / IRIS PRIO / BRIGHT
SLOW SHUTTER AUTO / MANUAL ---- AUTO effect only FULL AUTO mode
IRIS CLOSE / F22 / F19 / F16 / F14 / F11 / F9.6 / F8.0 / F6.8 / F5.6 / F4.8 /
 F4.0 / F3.4 / F2.8 / F2.4 / F2.0 / F1.6 / F1.4
GAIN 0 / 2 / 4 / 6 / 28 / -3 DB
BRIGHT 0, 2, 3, 4 29, 30
SHUTTER 1/1 , 1/2 , 1/4(3), 1/8(6). .. 1/4000, 1/6000, 1/10000
SAVE AND EXIT (ESC TO CANCEL)

NOTE : Values in () are for PAL Camera.

• LINE LOCK CONTROL

```
LINE LOCK SETUP

MODE      :          INTERNAL
PHASE     :          125
EXIT(ESC TO EXIT)
```

MODE INTERNAL / EXTERNAL Adjusts phase of picture with other
PHASE 0~255 cameras in EXTERNAL mode.
EXIT (ESC TO EXIT)

• NIGHT SHOT MENU

The NIGHT SHOT option removes the IR cutoff filter of the camera and makes the camera sensitive to near infrared. The picture will appear greenish. This may be suppressed by setting the BLACK & WHITE option to ON.

The operator can enable NIGHT SHOT for all dome cameras at the same time.

If the NIGHT SHOT mode is set to GLOBAL, "999" + **ENTR/GLBL** will turn Off the NIGHT SHOT mode

"888" + **ENTR/GLBL** will turn On the NIGHT SHOT mode.

```
NIGHT SHOT SETUP

MODE                   : MANUAL
LOCAL CONTROL         : OFF
EXIT(ESC TO CANCEL)
```

MODE MANUAL / AUTO / GLOBAL
AUTO: Camera goes in to B&W mode at low light.
GLOBAL: Controlled by remote (888+**ENTR/GLBL**).
MANUAL CONTROL ON / OFF
MANUAL: ON/OFF will enable and disable Night Shot mode of an individual camera.

3.13 Camera (Eighth Item of Main menu) – HID2404HCExxx MODEL

NOTE: The menu features will vary depending on the camera module installed in your dome camera.

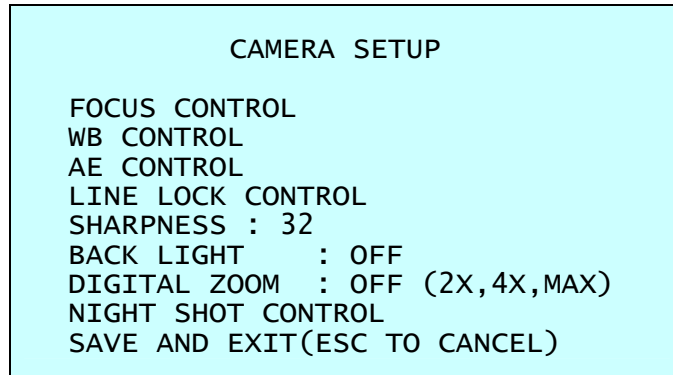

SHARPNESS The higher the value, the more edges in the picture will be enhanced (0~63).

BACK LIGHT Objects in front of bright backgrounds will be clearer with BLC ON.

Digital ZOOM OFF : Zoom range is limited to the optical.

2x : Zoom is extendable up to 2x of digital range.

4x : Zoom is extendable up to 4x of digital range.

MAX: Zoom is extendable Max digital Zoom range.

• FOCUS CONTROL

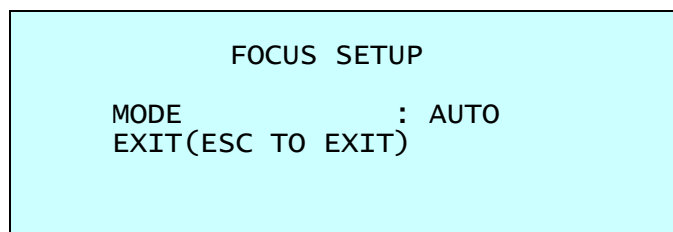

MODE : AUTO / MANUAL

Use manual mode in normal use.

CAUTION: Avoid continuous, 24-hour use of the auto focus. This will shorten the lifespan of the lens.

• **WB (white balance) CONTROL**

```

WB SETUP

MODE      :      AUTO
R GAIN    :      133
B GAIN    :      133
EXIT(ESC TO EXIT)
  
```

MODE MANUAL / AUTO
 RGAIN 0 ~ 255
 BGAIN 0 ~ 255

Use the AUTO mode for normal use.

RGAIN / BGAIN modes are controllable only in MANUAL Mode

Push the **Joystick** to the right or left to change.

• **AE CONTROL**

```

AE SETUP

MODE          : AE (DSS)
SLOW SHUTTER : 1/4
IRIS          : F2.4
GAIN          : 0 DB
WDR MODE     : ON
SHUTTER      : AUTO
SAVE AND EXIT(ESC TO CANCEL)
  
```

MODE SHUTTER PRIO / IRIS PRIO / AGC PRIO / AE (DAWN) / AE (DARK) / AE (DSS)

AE (DAWN) Under the low light condition when night shot mode is AUTO, IR Cut filter is automatically turned on and off.

AE (DARK) IR Cut filter is automatically turned on and off more dark condition than AE (DAWN)

AE (DSS) Automatic Exposure without switching IR Cut filter

SLOW SHUTTER OFF , 1/60 , 1/30 , 1/ 15 , 1/8 , 1/4 , 1/2 ---- AE (DSS) mode only.

IRIS F1.6 / F2.2 / F3.2 / F4.4 / F6.4 / F8.8 / F12 / F17/F24/F34

GAIN 0, 6, 12 , 18 , 24 , 30 DB

WDR MODE Wide Dynamic Range Technology uses two shutter speeds in alternative video fields-high and normal- every 60th (or 50th) of a second and combines two fields into one progressive scan frame. It allows every detail to be captured accurately even if one portion of an image is brilliantly bright while other portions are dark.

SHUTTER 1/2 , 1/4 , 1/8 , 1/15 , 1/30 , 1/60 , 1/120 , 1/180 , 1/250 , 1/500 , 1/1000 , 1/2000 , 1/4000 , 1/10,000 , 1/30,000
 (1/1.5 , 1/3 , 1/6 , 1/12 , 1/25 , 1/50 , 1/100 , 1/150 , 1/250 , 1/500 , 1/1000 , 1/2000 , 1/4000 , 1/10,000 , 1/30,000)

NOTE : Values in () are for PAL Camera.

• LINE LOCK CONTROL

```
LINE LOCK SETUP

MODE   :          INTERNAL
PHASE  :          125
EXIT(ESC TO EXIT)
```

MODE INTERNAL / EXTERNAL Adjusts phase of picture with other
PHASE 0~255 cameras in EXTERNAL mode.
EXIT (ESC TO EXIT)

• NIGHT SHOT MENU

The NIGHT SHOT option removes the IR cutoff filter of the camera and makes the camera sensitive to near infrared. The picture will appear greenish. This may be suppressed by setting the BLACK & WHITE option to ON.

The operator can enable NIGHT SHOT for all dome cameras at the same time.

If the NIGHT SHOT mode is set to GLOBAL, "999" + **ENTR/GLBL** will turn Off the NIGHT SHOT mode

"888" + **ENTR/GLBL** will turn On the NIGHT SHOT mode.

```
NIGHT SHOT SETUP

MODE                   : MANUAL
LOCAL CONTROL         : OFF
EXIT(ESC TO CANCEL)
```

MODE AUTO / MANUAL / GLOBAL
AUTO: Camera goes in to B&W mode at low light.
GLOBAL: Controlled by remote (888+**ENTR/GLBL**).
MANUAL CONTROL ON / OFF
MANUAL: ON/OFF will enable and disable Night Shot mode of an individual camera.

3.14 Dome Setup (Ninth Item of Main menu)

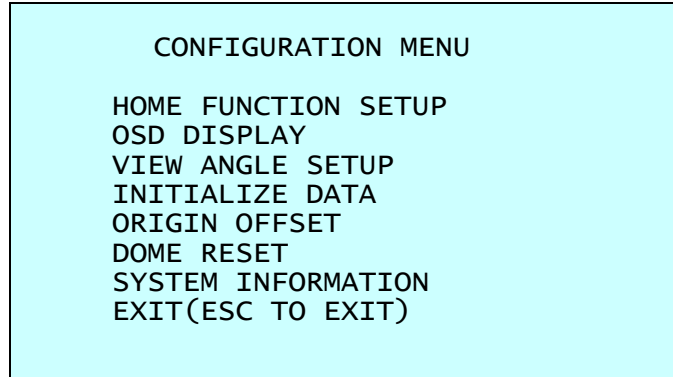

• HOME FUNCTION SETUP

After a dome control menu item has been selected, follow the directions below to set the function.

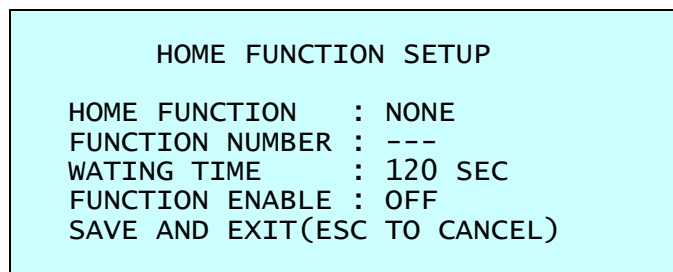

HOME FUNCTION : None/ Preset/ Tour/ Pattern/ Auto Scan
FUNCTION NUMBER : xxx
WAITING TIME : 10~240 Seconds
FUNCTION ENABLE : ON/ OFF

The Home function can be set so that the camera automatically goes to Preset, Tour, Pattern, Auto Scan after the keyboard controller has been idle for a amount of time. For example, if the **Joystick** controller is idle for 10 seconds, the camera goes to preset 1.

Follow these steps to program the Home position:

1. Press **MENU** to display the main menu on the monitor.
2. Select Home Function by pushing the **Joystick** to the right or to the left to scroll through the None, Tour, Pattern, Auto Scan and Preset functions.
3. Select Function Number by pushing the **Joystick** down, and push the **Joystick** to the right or to the left. The executable function number will scroll. Each function has maximum numbers. For example, you can have 240 Presets, 8 Tours, 4 Patterns and 8 Auto Scan options.
4. Select Function Time by pushing the **Joystick** down. Push the **Joystick** to the right or to the left to select from 10 to 240 seconds.
5. Select Function Enable by pushing the **Joystick** down. Turn the Home Enable ON or OFF by pushing the **Joystick** to the right or to the left.

• OSD DISPLAY

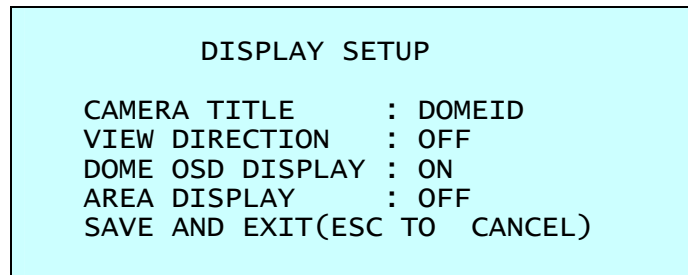

CAMERA TITLE : 8 CHARACTER CAN BE SET
VIEW DIRECTION : ON / OFF
DOME OSD DISPLAY : ON / OFF
AREA DISPLAY : ON / OFF

• VIEW DIRECTION

“ON” sets current direction as N(north) and the coordinate angle to 000. “OFF” hides the directional title. Every 90 degrees of clockwise rotation will change the title to E(East), S(South), W(West). If using the ON/OFF option frequently, it is recommended that you set “North” as a Preset. Recall the “North” Preset before enabling the directional title.

• DOME OSD DISPLAY

All display or title will disappear when DOME OSD DISPLAY sets OFF

• AREA DISPLAY

If this option is enabled, the nearest area title will be displayed when the camera is moving whether by manual operation, Auto Scan, or Pattern. Select ON or OFF by pushing the **Joystick** to the right or to the left. The Dome camera’s OSD will override this function (Dome camera’s OSD must be enabled).

VIEW ANGLE SETUP

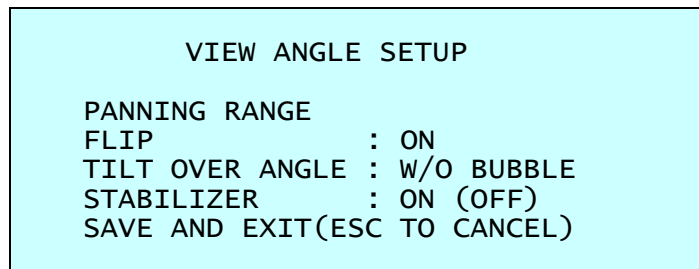

STABILIZER When the Image Stabilizer Function is ON, it helps in obtaining a stable image free of vibration caused by jarring movements. For a vibration frequency of around 10 Hz, correction is approximately 90%.(HID2404SHE11X model only)

• PANNING RANGE

When the dome camera is installed near a wall, panning range can be limited by user.

```
PANNING RANGE SETUP
RIGHT LIMIT : 000.0
LEFT LIMIT  : 000.0
ENABLE      : OFF
SWAP RIGHT/LEFT
SAVE AND EXIT(ESC TO CANCEL)
```

• FLIP

Allows the dome camera to automatically turn 180 degrees when the camera tilts to its lower position.

When the camera reaches the floor directly above the moving object, it will stop. Release the **Joystick** handle instantly and then pull down to run the flip function. The tracking speed will be the same as previous.

• TILT OVER ANGLE

This option is used to set the limit of the horizontal view angle so that the trim ring or ceiling does not obstruct the horizontal image when zooming out (wide angle).

ON: In some installations it is desirable for the dome camera to be able to see above the horizon. When this option is chosen, the dome will tilt up over the horizon(About 10 degrees). When the lens is zoomed out, you can see the ceiling line. But when the lens is zoomed in, the viewing angle is narrower, and the ceiling line disappears.

Without Bubble: The tilt range of the camera is limited to see the horizon so the picture shows part of the ceiling line.

With Bubble: The tilt range of the camera is limited to see below the horizon (- 10 degrees). Over Angle is not sufficient enough to avoid ceiling obstructions, please adjust Origin Offset of tilt angle as described below.

• INITIALIZE DATA

```
INITIALIZE DATA
FACTORY DEFAULT
ERASE PROGRAMMED DATA
EXIT(ESC TO EXIT)
```

Erase all stored data from the Flash-ROM of the selected dome camera. You will be asked to enter Yes or No. If you intend to erase all data then press the **MENU** key, otherwise press the **ESC** key to exit without erasing. The erased data includes all stored data (titles, presets, and tours....) except origin offset.

The offset value is still valid after all data is erased. The offset value can be zeroed only with default set of Offset origin menu.

CAUTION: All the data in the selected dome camera will be lost unless you download the data into a safe place. (Refer to Download/ Upload data function in the Keyboard Configuration utility.) Data from the selected dome camera can be stored in the keyboard controller temporarily. If you want to save the data of all installed dome cameras, you need a special I/O interface and software for PC.

• ORIGIN OFFSET

This feature is useful to align a new dome camera exactly the same as the previously installed dome camera.

Dome camera's origin set and all data initialize option do not override offset values. Only the default set option in this menu will set the offset value to zero. This can be used to avoid ceiling obstructions.

• DOME RESET

This feature is used to re-calibrate the orientation of a selected dome camera. Origin offset value is not affected by this function. (Offset is still valid after origin set)

• SYSTEM INFORMATION

```
SYSTEM INFORMATION
CAMERA TYPE      : XXXXXXXX
H/W VERSION      : V1.0
ROM VERSION      : V1.0
PROTOCOL         : F2E
BUADRATE         : 9600BPS
EXIT(ESC TO EXIT)
```

A Dome camera's Setup menu provides essential information about the dome camera if service is required. When you view this screen, you can determine the camera type, ROM version. The information on this screen cannot be modified.

Appendix A — Specifications

Camera(HID2404SLExxx)	
Image Sensor	1/4" Super HAD Color CCD (Sony)
Picture elements	NTSC : 768x494 Approx. 380K pixels PAL : 752x582 Approx. 440K pixels
Horizontal Resolution	470 / 460 lines(NTSC/PAL)
Lens	18x optical zoom with auto focus 12x digital zoom F1.4 to F3.0, f=4.1mm to 73.8mm
View angle	Approx. 48° (WIDE end) to 2.7° (TELE end)
Minimum Illumination	1.0 Lux(F1.4,normal shutter speed)
S/N ratio	more than 50dB

Camera(HID2404SMExxx)	
Image Sensor	1/4" Exview HAD Color CCD (Sony)
Picture elements	NTSC : 768x494 Approx. 380K pixels PAL : 752x582 Approx. 440K pixels
Horizontal Resolution	470 / 460 lines(NTSC/PAL)
Lens	18x optical zoom with auto focus 12x digital zoom F1.4 to F3.0, f=4.1mm to 73.8mm
View angle	Approx. 48° (WIDE end) to 2.7° (TELE end)
Minimum Illumination	0.7 Lux(F1.4,normal shutter speed) 0.05 lux (F1.4, 1/4S(NTSC) OR 1/3S(PAL)) 0.01 Lux (1/4s with IR Cut Filter Removed)
S/N ratio	more than 50dB

Camera(HID2404SHExxx)	
Image Sensor	1/6" Super HAD Color CCD (Sony)
Picture elements	NTSC : 768x494 Approx. 680K pixels PAL : 752x582 Approx. 800K pixels
Horizontal Resolution	470 / 460 lines(NTSC/PAL)
Lens	25x optical zoom with auto focus 12x digital zoom F1.6 to F2.7, f=2.4mm to 60mm

View angle	Approx. 45° (WIDE end) to 2° (TELE end)
Minimum Illumination	2.5 lux(F1.4,normal shutter speed) 0.2 lux (F1.4,1/4S(NTSC) OR 1/3S(PAL)) 0.01 lux (1/4s with IR Cut Filter Removed)
S/N ratio	more than 49Db
Image stabilizer	ON/OFF

Camera(HID2404HCExxx)	
Image Sensor	1/4" Progressive scan CCD
Picture elements	NTSC : 758x504 Approx. 380K pixels PAL : 758x592 Approx. 450K pixels
Horizontal Resolution	470 / 470 lines(NTSC/PAL)
Lens	23x optical zoom with auto focus 10x digital zoom F1.6 to F3.6, f=3.6mm to 82.8mm
View angle	Approx. 54° (WIDE end) to 2.5° (TELE end)
Minimum Illumination	3.0 lux(F1.4,normal shutter speed) 0.2 lux (F1.4,1/4S(NTSC) OR 1/3S(PAL)) 0.02 lux (1/4s with IR Cut Filter Removed)
S/N ratio	more than 50dB
WDR	ON/OFF

General	
Certification	CE EMC, FCC CLASS A, UL
Electrical	
Input Voltage	18 to 30 VAC; 24 VAC nominal, built-in power-line surge
Power Requirement	24 VAC/VDC 850mA
Power Consumption	Maximum 20W
Alarm Output	4 Normal relays 24 VDC/1A Max (selectable NC/NO)
Alarm Input	8 Normal dry contact (selectable NC/NO)
Control	RS-485/422 baud rate: 2400 ~230k bps (default:9600bps)
Access Time	0.75 second maximum preset recall time
ID (Camera Address)	999 (Factory mode selectable over 999 camera)
Mechanical	
Dimension	See Figure 10
Weight	Approx 1.2 kg
Pan Angle	360° continuous rotation
Speed	0.1° to 90°/sec. (proportional to zoom)
	360°/sec. maximum (with CTRL/PGM key pressed)
	Preset Speed : 380°/sec
Repeatability	0.2°
Flip	Rotate 180° at bottom of tilt
Autoscan	8 auto scan include vector scan.
Preset Position	240 positions with camera status (16-character title)
Tour	8 tours
Pattern	Four patterns, 240 second
On-Screen Display	Displays camera ID and area name on screen
Environment	
Operating temperature	0°C to 50°C (32°F to 122°F)
Operating humidity	0 to 90%RH (non-condensing)
Storage temperature	-20°C to 60°C (4°F to 140°F)

Specifications are subject to change without notice.

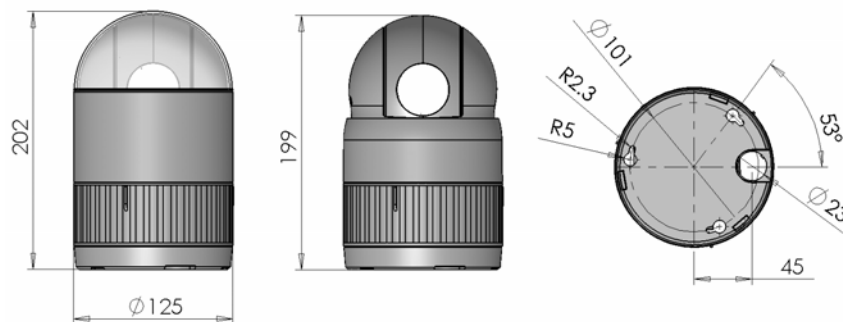

Figure 10– Dimension

Appendix B — Troubleshooting

If problems occur, verify the installation of the camera with the instructions in this manual and with other operating equipment. Isolate the problem to the specific piece of equipment in the system and refer to the equipment manual for further information.

Problem	Possible Solution
No video.	Verify that power is connected to all pieces of equipment in the system. Verify that the power switches are in the ON position. Check the video connections (see Figure 4).
Poor video quality.	Check that the BNC connectors are inserted properly. Check the voltage level of the dome camera. Check that 8-pin cable is connected to the Keyboard. 8-pin cable for Keyboard is proprietary. Cable for video is shielded.
Dome cameras lose their positions.	Reset the cameras using the Dome configuration menus. Check that the dome cameras are inserted properly in the base. Check the voltage level of the dome camera.
Camera number does not match the multiplexer number.	Check the camera ID and insert the BNC cable into the proper input of the multiplexer.
Picture is torn when switching	Check Line Lock setting and adjust phase of L/L (see page 22)

Appendix C — Glossary

Alarm Actions

The assigned responses for the dome camera when inputs change from normal to abnormal states. The dome may run a Preset, Pattern, or have no assigned action for each of the four dome inputs. The dome may also send alarm states to the host controller for processing. See also Input and Normal Input State.

Areas

Programmed start and end points of the dome's field of view around its pan axis. Each area is a part of a circular viewing area that extends around the dome. The areas can be different sizes. Up to 16 areas can be programmed for the dome.

Automatic Gain Control (AGC)

Allows for the amplification of the video signal in scenes with minimal ambient light. Many low-light scenes result in picture noise. As gain is increased, the picture noise is also amplified. When AGC is enabled, the value of the gain setting is based on feedback from the camera. When AGC is disabled, the camera uses the value set for the manual gain setting. The trade-off between picture level and noise may be adjusted when AGC is disabled.

On-screen Menu

The text overlay menu system used for setting dome features. The utility is accessed using a keystroke combination. The utility provides settings for camera functions, zoom, alarms, text display, and password protection.

Flip

Allows the dome to automatically turn 180 degrees when the camera tilts to its lower limit and stays in that position for a brief delay. When the dome flips (rotates), the camera starts moving upward as long as the tilt control is kept in the down position. Once the control is released, the tilt control returns to its normal operational mode. The flip feature is useful when you need to track someone who walks directly beneath the dome and continues on the other side.

Home Position

The default position to which the dome camera returns after an assigned period of inactivity passes. The default position may be a Preset, Tour, Pattern, or No Action.

Input Alarm

A connection point on the dome camera that enables the system to monitor Input Devices. There are four inputs available for the dome camera.

Input Devices

External devices that provide information about the condition of system components that connect to the inputs on the dome camera. Typical input devices include door contacts, motion detectors and smoke detectors.

IR Mode

A feature of the camera that permits manual or automatic switching between color and IR (black-and-white) operation. When IR mode is active, clearer images may be obtained under low-light conditions.

Line Lock

Allows you to phase lock the video with the AC power line. When line lock is enabled, it prevents vertical video rolling when switching multiple cameras to a single monitor. If text appears slightly tinted on color monitors, disabling the line lock may prevent this problem.

Name Information

Relates to the display the dome name, the area where the dome is pointing, the name of the preset or pattern that is running, and alarm names. The display of each type of name setting can be enabled or disabled. When the display of camera or area title(name) is enabled, the information appears on the screen continuously. Preset, tour and pattern titles(names) appear only while they are active.

Normal Input State

Describes the expected state of a device connected to one of eight dome camera's inputs. The normal state may be open or closed. When a device is not in its normal input state, an alarm is issued.

North Position

User-definable setting that may correspond to magnetic north or some well-known landmark. Used to approximate the camera dome's pointing direction when Direction Indicators are enabled.

Low Shutter

Setting used to improve the quality of video obtained in extreme low-light situations. When the Low Shutter setting is enabled, low-light information is collected over multiple fields based on the Shutter Limit setting. As a result, video may appear blurred or choppy in extreme low-light situations. This setting does not effect camera operation in normal lighting situations. See also Automatic Gain Control (AGC).

Pattern

A series of pan, tilt, zoom and focus movements from a single programmable dome. Up to 8 patterns may be programmed for the dome camera.

Preset

Programmed video scene, based on a specific pan, tilt, zoom, and focus settings. Up to 240 presets may be programmed for the dome camera.

Privacy Zones

Masked areas of the dome camera's viewing area. These masks prevent operators of the surveillance system from viewing these designated zones. The Privacy Zones move in relation to the dome camera's pan/tilt position. In addition, the apparent size of the Privacy Zone adjusts automatically as the lens zooms in or out. Up to eight Privacy Zones may be established for a dome camera.

Shutter Limit

Setting used to define the maximum exposure time for the Open Shutter setting. The values for the setting range from 1/2 to 1/60. The default setting is 1/4.

Vector Scan

Move from start point to end point including tilt and zoom simultaneously and linearly.

WDR

Wide Dynamic Range Technology uses two shutter speeds in alternative video fields-high and normal- every 60th (or 50th) of a second and combines two fields into one progressive scan frame. It allows every detail to be captured accurately even if one portion of an image is brilliantly. Whether at the high shutter speed or normal shutter speed, the progressive scan CCD provides a horizontal resolution of 470 lines. As a result, combined fields yield a frame of high-quality images.

White balance

Adjustments in the color hue (red and blue) gains for a camera so that true white appears white in the image. It is normally compensated for by the automatic gain control. In some lighting conditions, you may need to manually adjust the red and blue settings for optimal viewing. When Automatic White Balance is enabled, the camera measures the image and automatically adjusts the red and blue settings to balance white. When Automatic White Balance is disabled, the camera uses the values set for the red and blue settings to balance white.

Appendix D — Short Cut Key

Short Cut Key	Function
PRST	Pop up preset setup menu.
TOUR	Pop up guard Tour setup menu.
PTRN	Pop up Pattern setup menu.
SCAN	Pop up Auto Scan setup menu.
NO.+ PGM + PRST	Store the current view at the selected number.
NO.+ PGM + TOUR	Pop up tour setup menu at the selected number.
NO.+ PGM + SCAN	Pop up auto scan setup menu at the selected number.
1 ~ 4 + ON	Turn On Relay.
1 ~ 4 + OFF	Turn Off Relay.
10 + ON	Night Shot on
10 + OFF	Night Shot off
11 + ON	BLC on
11 + OFF	BLC off
12 + ON	Digital Zoom on (According to digital zoom setting)
12 + OFF	Digital Zoom off
13 + ON	Dome OSD on
13 + OFF	Dome OSD off
14 + ON	Dome Area Title Display on
14 + OFF	Dome Area Title Display off
15 + ON	View Direction on
15 + OFF	View Direction off
100 + ON	Shutter speed auto
101 + ON	Shutter speed 1/4 (PAL 1/3)sec
102 + ON	Shutter speed 1/2 sec
103 + ON	Shutter speed 1 sec
104 + ON	WDR on
104 + OFF	WDR off
105 + ON	Stabilizer on
105 + OFF	Stabilizer off
150 + ON	Image Reverse on
150 + OFF	Image Reverse off

Free Manuals Download Website

<http://myh66.com>

<http://usermanuals.us>

<http://www.somanuals.com>

<http://www.4manuals.cc>

<http://www.manual-lib.com>

<http://www.404manual.com>

<http://www.luxmanual.com>

<http://aubethermostatmanual.com>

Golf course search by state

<http://golfingnear.com>

Email search by domain

<http://emailbydomain.com>

Auto manuals search

<http://auto.somanuals.com>

TV manuals search

<http://tv.somanuals.com>