

# AeroPilates<sup>®</sup> PRO XP686

## Owner's Manual

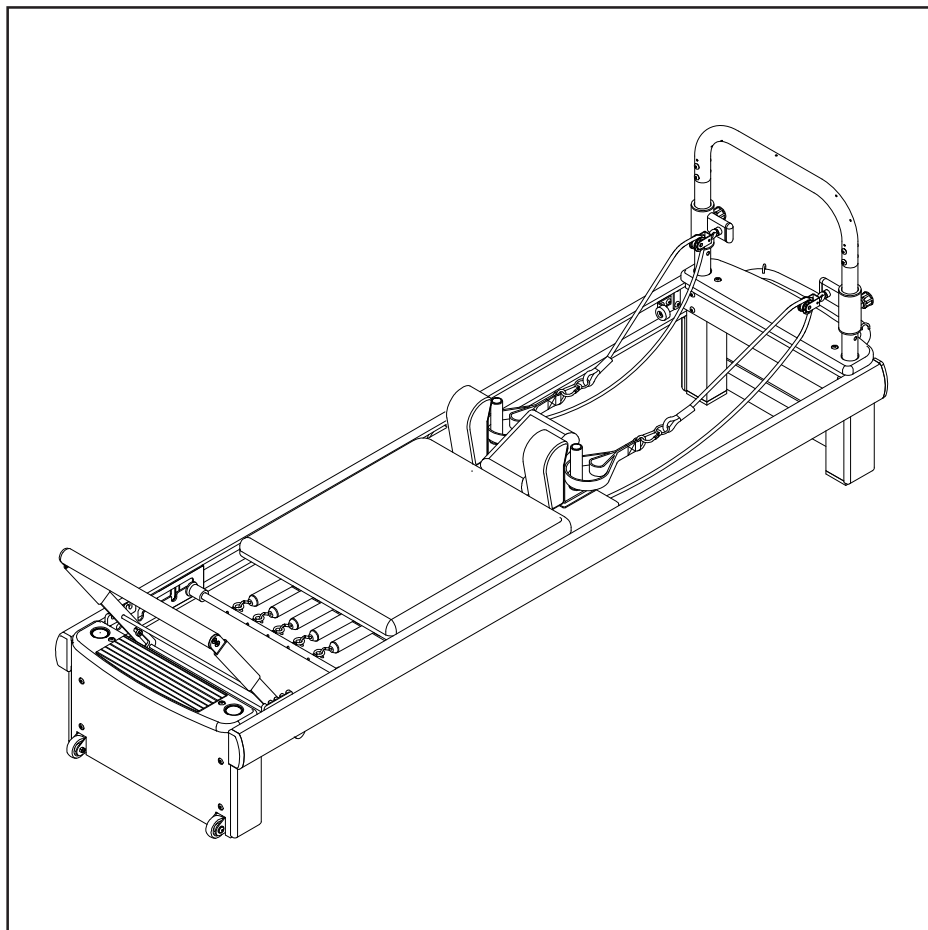

### ⚠ WARNING ⚠

Exercise can present a health risk. Consult a physician before beginning any exercise program with this equipment. If you feel faint or dizzy, immediately discontinue use of this equipment. Serious bodily injury can occur if this equipment is not assembled and used correctly. Serious bodily injury can also occur if all instructions are not followed. Keep others and pets away from equipment when in use. Always make sure all bolts and nuts are tightened prior to each use. Follow all safety instructions in this manual.

When calling for parts or service, please specify the following number.

**55-5686B**

**STAMINA PRODUCTS**

MADE IN CHINA

Product May Vary Slightly  
From Pictured.

#### CAUTION:

Weight on this product should not exceed 300 lbs.

This Product is Produced Exclusively by



2040 N. Alliance, Springfield, MO 65803

Customer Service Number

1 (800) 375-7520

[www.staminaproducts.com](http://www.staminaproducts.com)

## TABLE OF CONTENTS

	Page		Page
Safety Instructions	2	Maintenance	18
Before You Begin	4	Conditioning Guidelines	19
Equipment Warning & Notice Labels	5	Warm-Up and Cool-Down	20
Hardware Identification Chart	6	Warranty	21
Assembly Instructions	7	Product Parts Drawing	22
Side Roller Adjustment	15	Parts List	23
Operational Instructions	16	Notes	26
Storage	18	Fax/Mail Ordering Form	27

### SAFETY INSTRUCTIONS

**WARNING:** To reduce the risk of serious injury, read the following Safety Instructions before using the **AeroPilates® Pro XP686**.

1. We recommend that two people be available for assembly of this product.
2. Read all warnings posted on the **AeroPilates® Pro XP686**.
3. Read this Owner's Manual and follow it carefully before using the **AeroPilates® Pro XP686**. Make sure that it is properly assembled and tightened before use.
4. When exercising on this product, do not exercise at an intensity that causes the product itself to move. This could result in damage to your joints and the product.
5. Keep children away from the **AeroPilates® Pro XP686**. Do not allow children to use or play on the **AeroPilates® Pro XP686**. Keep children and pets away from the **AeroPilates® Pro XP686** when it is in use.
6. It is recommended that you place this exercise equipment on the floor mat.
7. Set up and operate the **AeroPilates® Pro XP686** on a solid level surface. Do not position the **AeroPilates® Pro XP686** on loose rugs or uneven surfaces.
8. Make sure that adequate space is available for access to and around the **AeroPilates® Pro XP686**.
9. Inspect the **AeroPilates® Pro XP686** for worn or loose components prior to use.
10. Tighten/replace any loose or worn components prior to using the **AeroPilates® Pro XP686**.
11. Consult a physician prior to commencing an exercise program. If, at any time during exercise, you feel faint, dizzy, or experience pain, stop and consult your physician.
12. Follow your physician's recommendations in developing your own personal fitness program.
13. Always choose the workout which best fits your physical strength and flexibility level. Know your limits and train within them. Always use common sense when exercising.
14. Do not wear loose or dangling clothing while using the **AeroPilates® Pro XP686**.
15. Be careful to maintain your balance while using, mounting, dismounting, or assembling the **AeroPilates® Pro XP686**, loss of balance may result in a fall and serious bodily injury.
16. The **AeroPilates® Pro XP686** should not be used by persons weighing over 300 pounds.
17. The **AeroPilates® Pro XP686** should be used by only one person at a time.

**WARNING:** Before starting any exercise or conditioning program you should consult with your personal physician to see if you require a complete physical exam. This is especially important if you are over the age of 35, have never exercised before, are pregnant, or suffer from any illness. **READ AND FOLLOW THE SAFETY PRECAUTIONS. FAILURE TO FOLLOW THESE INSTRUCTIONS CAN RESULT IN SERIOUS BODILY INJURY.**

# CALL US FIRST



**Customer Service Number**

**1(800) 375-7520**

---

**THANK YOU FOR PURCHASING THE  
*AeroPilates*® Pro XP686**

To help you get started, we have pre-assembled most of your *AeroPilates*® Pro XP686 at the factory with the exception of those few parts left unassembled for shipping purposes. Simply follow the few assembly instructions set forth in this manual. With regular workouts you will be getting your body into shape and on your way to achieving a happier and healthier lifestyle.

Should you have any questions,  
please call our Customer Service Department toll-free number,  
**1 (800) 375-7520**

**Monday - Thursday, 7:30 A.M. - 5:00 P.M. Central Time.  
Friday, 8:00 A.M. - 3:00 P.M. Central Time.**



**TELEPHONE**  
CUSTOMER SERVICE  
Tel: 1 (800) 375-7520



**FAX**  
CUSTOMER SERVICE  
Fax: (417) 889-8064



**ONLINE**  
CUSTOMER SERVICE  
[parts@staminaproducts.com](mailto:parts@staminaproducts.com)  
[cust-srvc@staminaproducts.com](mailto:cust-srvc@staminaproducts.com)  
[www.staminaproducts.com](http://www.staminaproducts.com)



**MAIL**  
STAMINA PRODUCTS, INC.  
ATTN: Customer Service  
P.O. Box 1071  
Springfield, MO. 65801-1071

## BEFORE YOU BEGIN

Thank you for choosing the **AeroPilates® Pro XP686**. We take great pride in producing this quality product and hope it will provide many hours of quality exercise to make you feel better, look better and enjoy life to its fullest.

Yes, it's a proven fact that a regular exercise program can improve your physical and mental health. Too often, our busy lifestyles limit our time and opportunity to exercise. The **AeroPilates® Pro XP686** provides a convenient and simple method to begin your assault on getting your body in shape and achieving a happier and healthier lifestyle.

Before reading further, please review the drawing below and familiarize yourself with the parts that are labeled.

Read this manual carefully before using the **AeroPilates® Pro XP686**.

Although Stamina constructs its products with the finest materials and uses the highest standards of manufacturing and quality control, there can sometimes be missing parts or incorrectly sized parts. If you have any questions or problems with the parts included with your **AeroPilates® Pro XP686**, please do not return the product. Contact us **FIRST!**

If a part is missing or defective, please call us toll free at 1-800-375-7520 (in the U.S.). Our Customer Service Staff is available to assist you from 7:30 A.M. to 5:00 P.M. (Central Time) Monday through Thursday and 8:00 A.M. to 3:00 P.M. (Central Time) on Friday.

If you would like to contact us online, go to our website at [www.staminaproducts.com](http://www.staminaproducts.com) and access the Customer Service section.

Be sure to have the name and model number of the product available when you contact us.

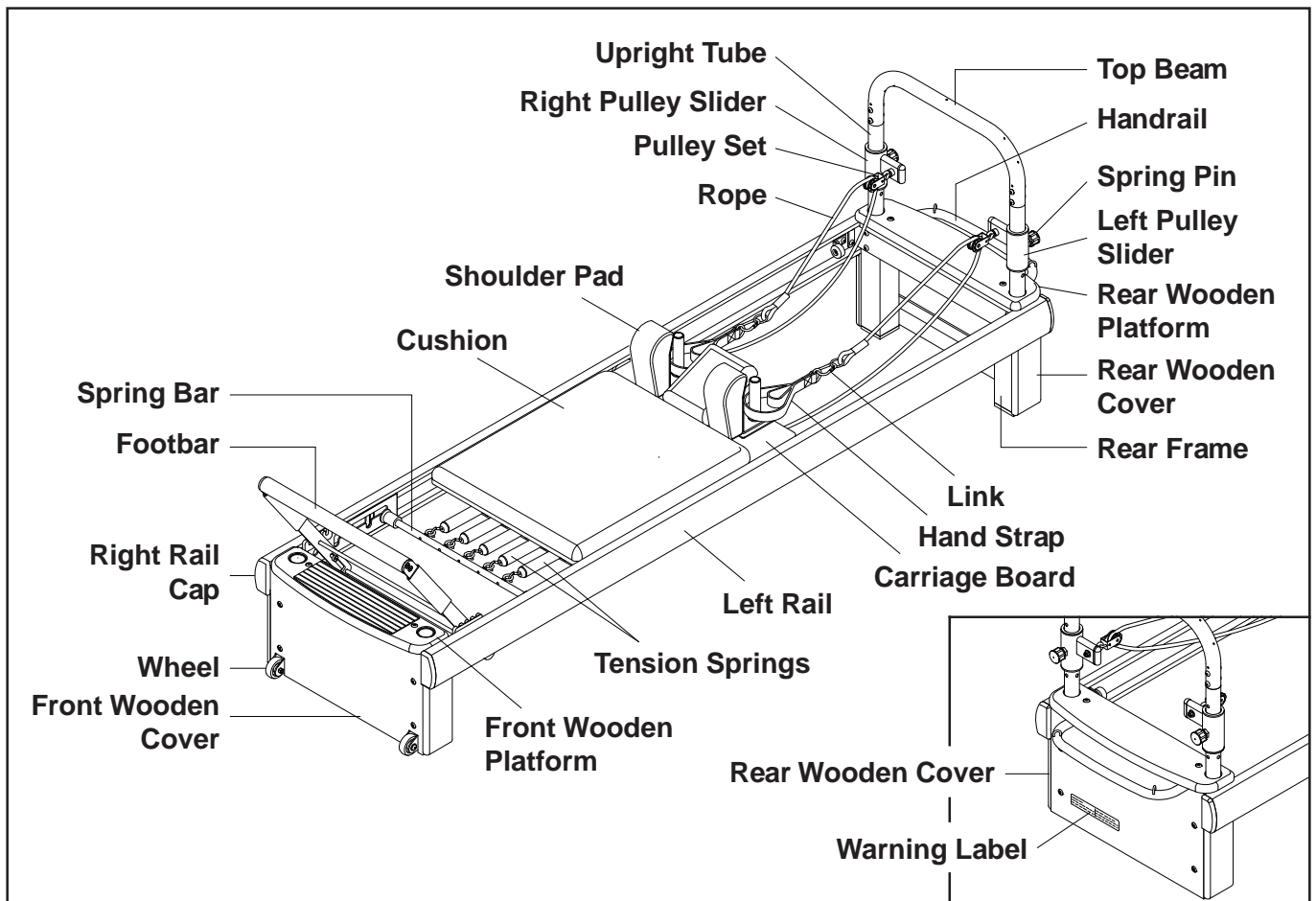

### THE FOLLOWING TOOLS ARE INCLUDED FOR ASSEMBLY :

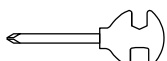

Combination Wrench

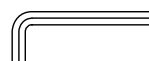

Allen Wrench (5mm)

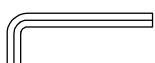

Allen Wrench (6mm)



Allen Wrench (4mm)

# EQUIPMENT WARNING & NOTICE LABELS

This chart is provided to help identify the warning & notice labels on the **AeroPilates® Pro XP686**. Please take a moment to familiarize yourself with all of the warning & notice labels.

Label is larger than actual size

## **W1** WARNING LABEL(106)

 <b>WARNING</b>	<p><b>Keep others including children &amp; pets away from equipment when in use.</b> BEFORE BEGINNING THIS OR ANY EXERCISE PROGRAM, CONSULT YOUR PHYSICIAN. THIS IS ESPECIALLY IMPORTANT FOR PERSONS OVER THE AGE OF THIRTY-FIVE OR WITH PREEXISTING HEALTH PROBLEMS. STAMINA® ASSUMES NO RESPONSIBILITY FOR PERSONAL INJURY OR PROPERTY DAMAGE SUSTAINED BY OR THROUGH THE USE OF THIS PRODUCT. Make sure all nuts and bolts are tightened, and follow all safety tips and instructions set forth herein. This product should not be used by persons weighing more than 250 lbs. unless otherwise stated in the front of your manual.</p>
<p>Failure to comply with these warnings could result in serious injury or death. All warnings and instructions are to be read prior to use. Replace this warning label if damaged, illegible, or removed.</p>	

# HARDWARE IDENTIFICATION CHART

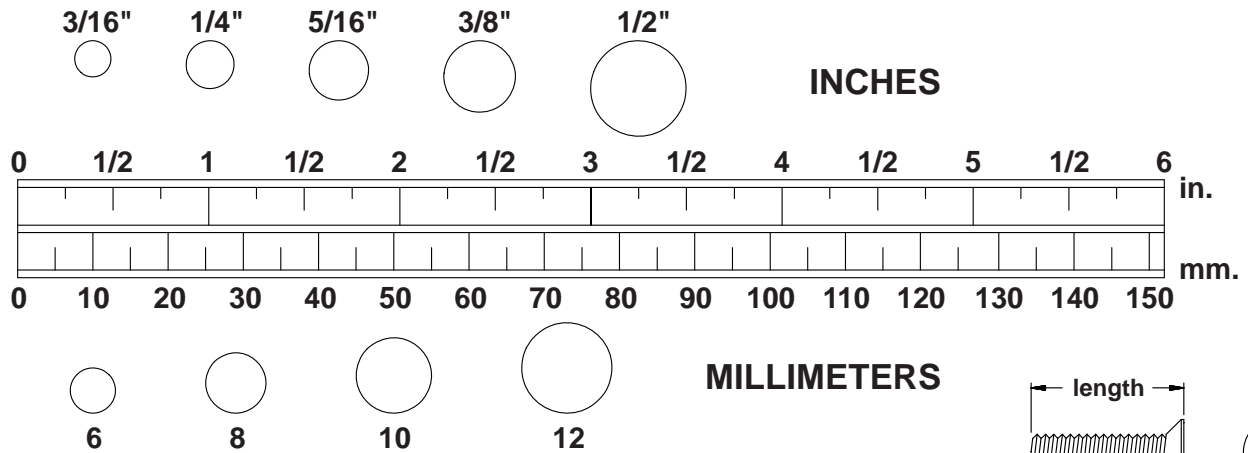

This chart is provided to help identify the hardware used in the assembly process. Place the washers, the end of the bolts, or screws on the circles to check for the correct diameter. Use the small scale to check the length of the bolts and screws.

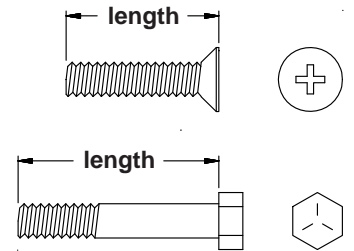

**NOTICE:** The bolt length is measured from the bottom of the head of the bolt to the end of the bolt. The head of the bolt is not included in the measurement unless the it is a flat head screw or bolt.

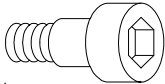
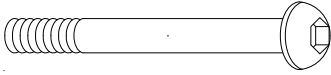
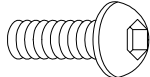
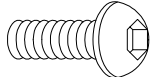
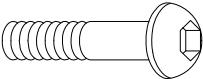
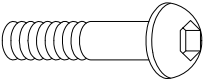
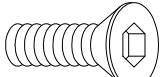
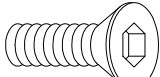
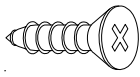

After unpacking the unit, open the hardware bag and make sure that you have all the following items. Some hardware may be already attached to the part.

	Part No. and Description	Qty
	24 Pivot Bolt	2
	84 Bolt, Button Head (M6 x 1 x 82mm)	6
	85 Bolt, Button Head (M8 x 1.25 x 15mm)	24
	86 Bolt, Button Head (M8 x 1.25 x 25mm)	8
	88 Bolt, Button Head (M8 x 1.25 x 35mm)	12
	89 Bolt, Button Head (M8 x 1.25 x 42mm)	2
	93 Bolt, Flat Head (M6 x 1 x 15mm)	2
	94 Bolt, Flat Head (M8 x 1.25 x 15mm)	2
	99 Screw, Flat Head (M4.5 x 15mm)	8
	103 Nylock Nut (M8 x 1.25)	4
	104 Washer (M8)	4



## ASSEMBLY INSTRUCTIONS

Place all parts from the box in a cleared area and position them on the floor in front of you. Remove all packing materials from your area and place them back into the box. Do not dispose of the packing materials until assembly is completed. Read each step carefully before beginning. If you are missing a part please call our toll-free number for assistance **1 (800) 375-7520** or e-mail us at : **parts@staminaproducts.com**

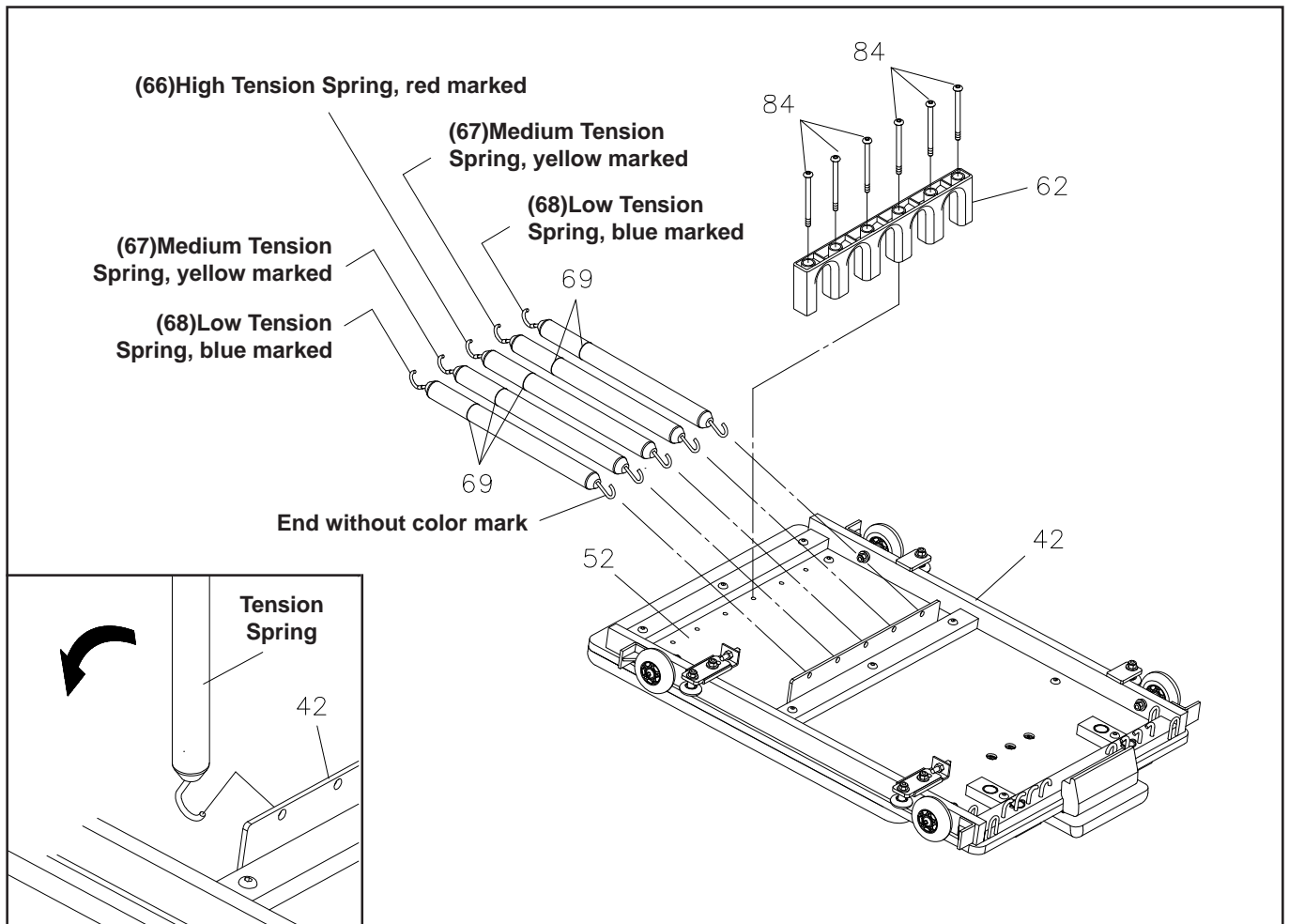

### STEP 1

There are three different levels of tension springs, **HIGH TENSION SPRING, RED MARKED(66)**, **MEDIUM TENSION SPRING, YELLOW MARKED(67)**, and **LOW TENSION SPRING, BLUE MARKED(68)**. Place the **CARRIAGE(42)** upside down on the floor. Hook the ends of the **TENSION SPRINGS(66, 67, 68)** without color marks into the positions shown in the illustration. The blue marked springs are in the outside positions, the red marked spring is in the center position, and the yellow marked springs are between the red and blue springs.

- HINT:** 1. Refer to the inset drawing. Hold the spring in a vertical position and hook it onto the plate on the **CARRIAGE(42)** as shown.  
2. Make sure that the spring is hooked in the direction shown in the inset drawing.

### STEP 2

**NOTE:** There are **TENSION SPRING SLEEVES(69)** on the springs. Make sure the **TENSION SPRING SLEEVES(69)** cover on the springs smoothly and stay between the springs and **SPRING HOLDER (62)**.

Attach the **SPRING HOLDER(62)** to the **CARRIAGE BOARD(52)** with **BUTTON HEAD BOLTS (M6x1x82mm)(84)**.

## ASSEMBLY INSTRUCTIONS

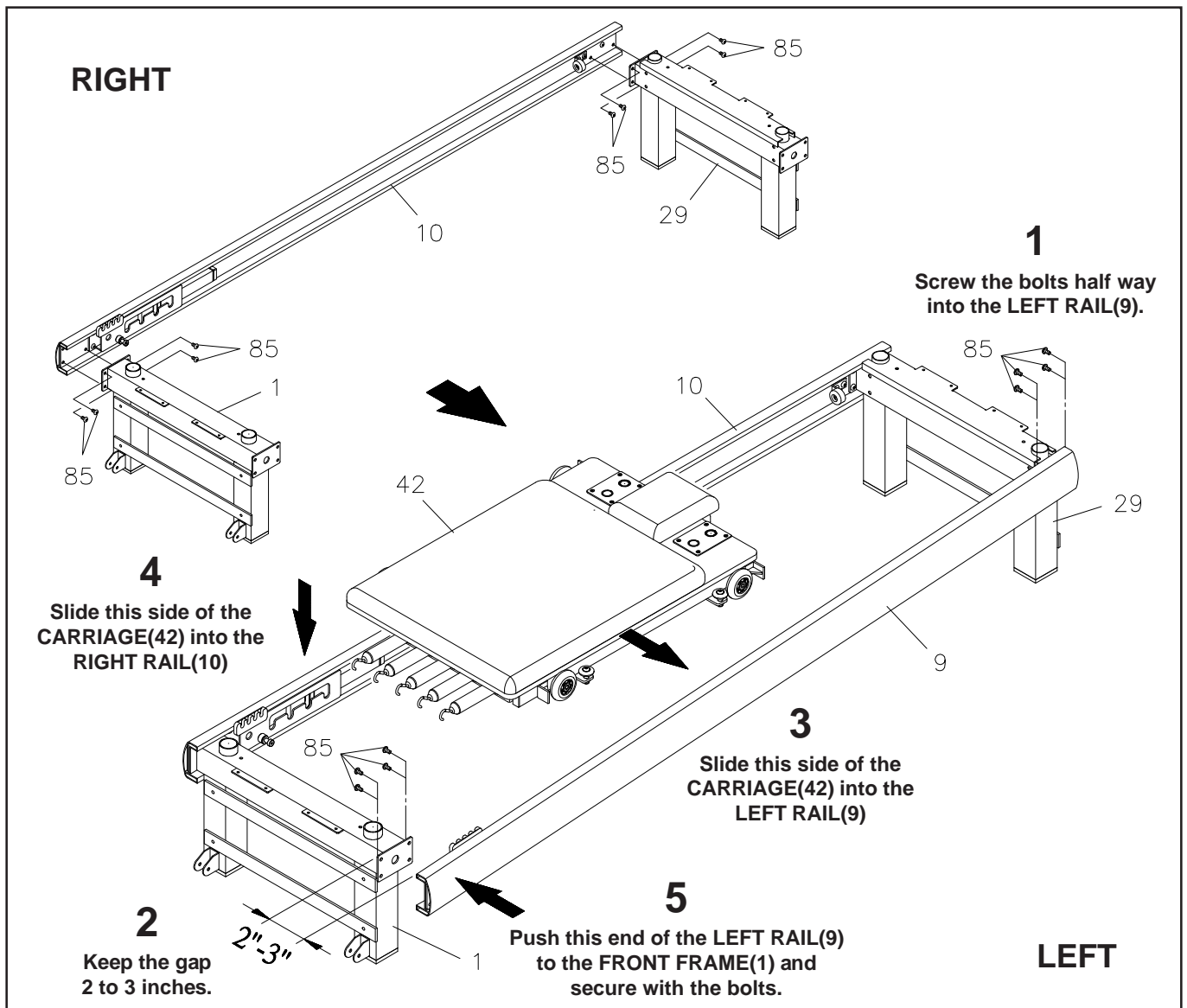

**STEP 3:** Attach the **RIGHT RAIL(10)** to the **FRONT FRAME(1)** and **REAR FRAME(29)** with **BUTTON HEAD BOLTS(M8x1.25x15mm)(85)**.

**HINT:** Study the illustration carefully to make sure that the **FRONT FRAME(1)** and **REAR FRAME(29)** are not reversed. The **FRONT FRAME(1)** has brackets for the **WHEELS(8)** near the bottom and small holes on the top surface. Make sure that the **RAILS(9, 10)** are not upside down. Make sure that the **LEFT RAIL(9)** and **RIGHT RAIL(10)** are not reversed.

**STEP 4:** Please use two people to assemble the **AeroPilates® Pro XP686**. Use the following procedure to assemble the **LEFT RAIL(9)** and **CARRIAGE(42)**:

**NOTE:** Review sequence one through five in the illustration above before beginning this procedure.

- Have your assistant hold the front end of the **LEFT RAIL(9)**. Attach the back end of the **LEFT RAIL(9)** to the **REAR FRAME(29)** with **BUTTON HEAD BOLTS(M8x1.25x15mm)(85)**. Screw the bolts half way into the **LEFT RAIL(9)**.
- Keep the gap between front end of the **LEFT RAIL(9)** and the **FRONT FRAME(1)** about two to three inches. Then lift up the **CARRIAGE(42)** and slide it into the rails as shown in the illustration.
- Push the front end of the **LEFT RAIL(9)** to the **FRONT FRAME(1)** and secure with **BUTTON HEAD BOLTS(M8x1.25x15mm)(85)**. Tighten all the bolts.



## ASSEMBLY INSTRUCTIONS

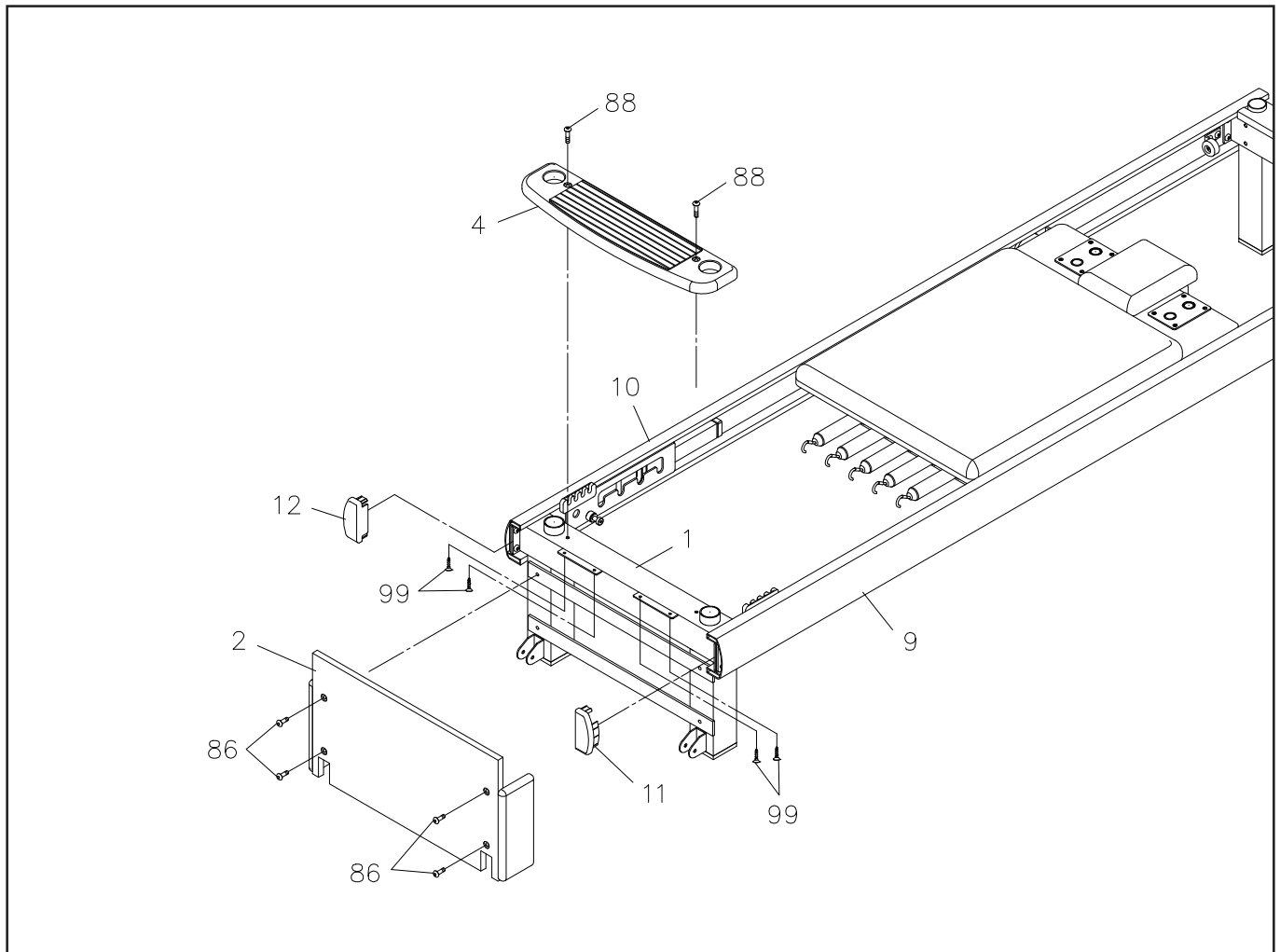

### STEP 5

Attach the **FRONT WOODEN PLATFORM(4)** to the **FRONT FRAME(1)** with **BUTTON HEAD BOLTS (M8x1.25x35mm)(88)** from the top and **FLAT HEAD SCREWS(M4.5x15mm)(99)** from the bottom.

### STEP 6

Attach the **FRONT WOODEN COVER(2)** to the **FRONT FRAME(1)** with **BUTTON HEAD BOLTS (M8x1.25X25mm)(86)**. Press the **LEFT** and **RIGHT RAIL CAPS(11, 12)** into the **LEFT** and **RIGHT RAILS (9, 10)**.

## ASSEMBLY INSTRUCTIONS

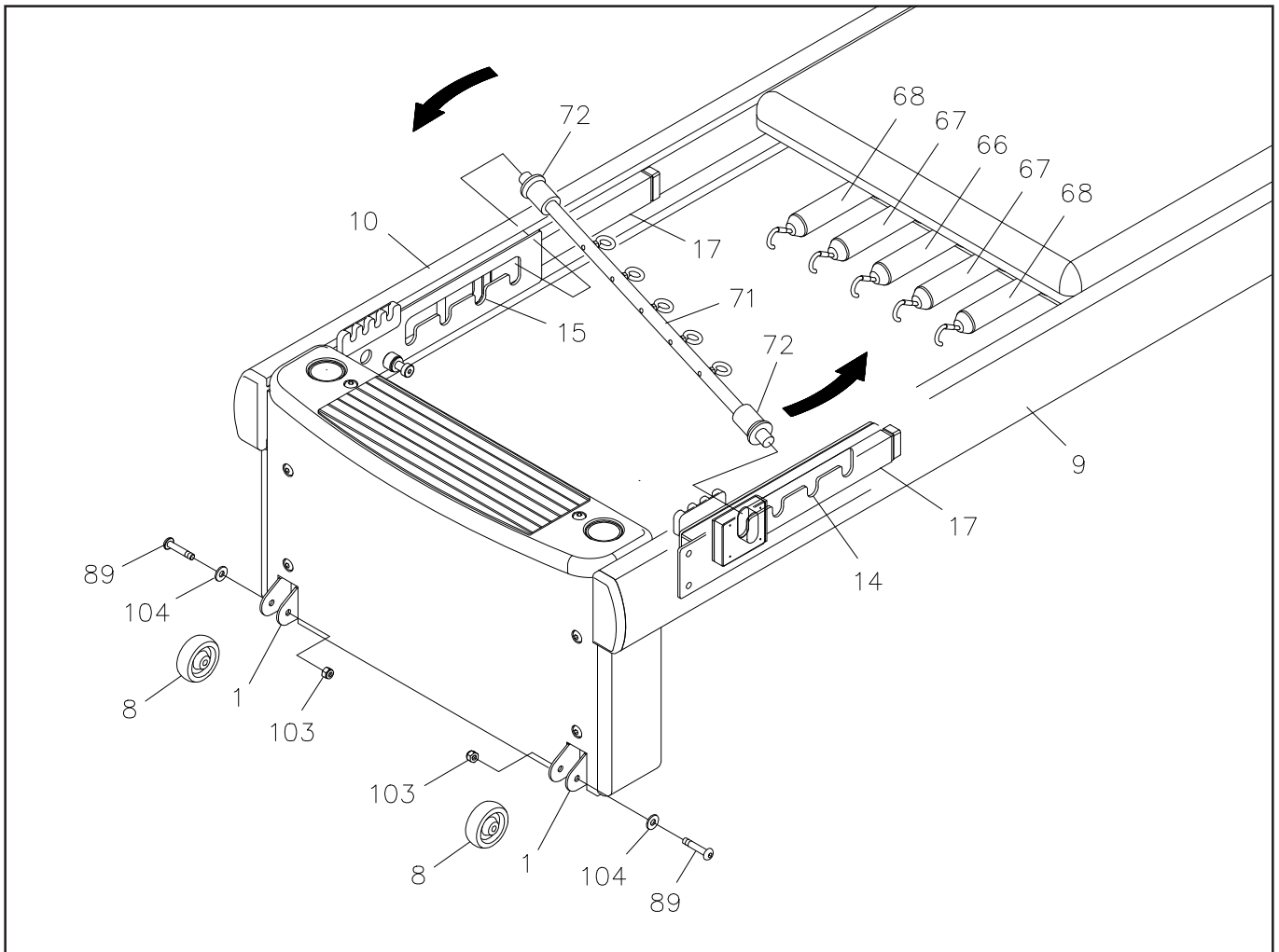

### STEP 7

Attach the **WHEELS(8)** to the **FRONT FRAME(1)** with **BUTTON HEAD BOLTS(M8x1.25x42mm)(89)**, **WASHERS(M8)(104)**, and **NYLOCK NUTS(M8x1.25)(103)**.

### STEP 8

Refer to the illustration. Set the **BUMPER SLIDER(17)** in the **RIGHT GEAR GUIDE(15)** to the rear-most position. Set the **BUMPER SLIDER(17)** in the **LEFT GEAR GUIDE(14)** to the front-most position.

Make the screws attaching the **SLEEVES(72)** to the **SPRING BAR(71)** face down. Insert the left end of the **SPRING BAR(71)** into the slot in the left **BUMPER SLIDER(17)** and insert the right end of the **SPRING BAR(71)** into the slot in the right **BUMPER SLIDER(17)**. The **SPRING BAR(71)** must be at an angle to do this. After both ends of the **SPRING BAR(71)** are in the slots in the **BUMPER SLIDERS(17)**, align the **SPRING BAR(71)** so that it is perpendicular to both **RAILS(9, 10)**.

## ASSEMBLY INSTRUCTIONS

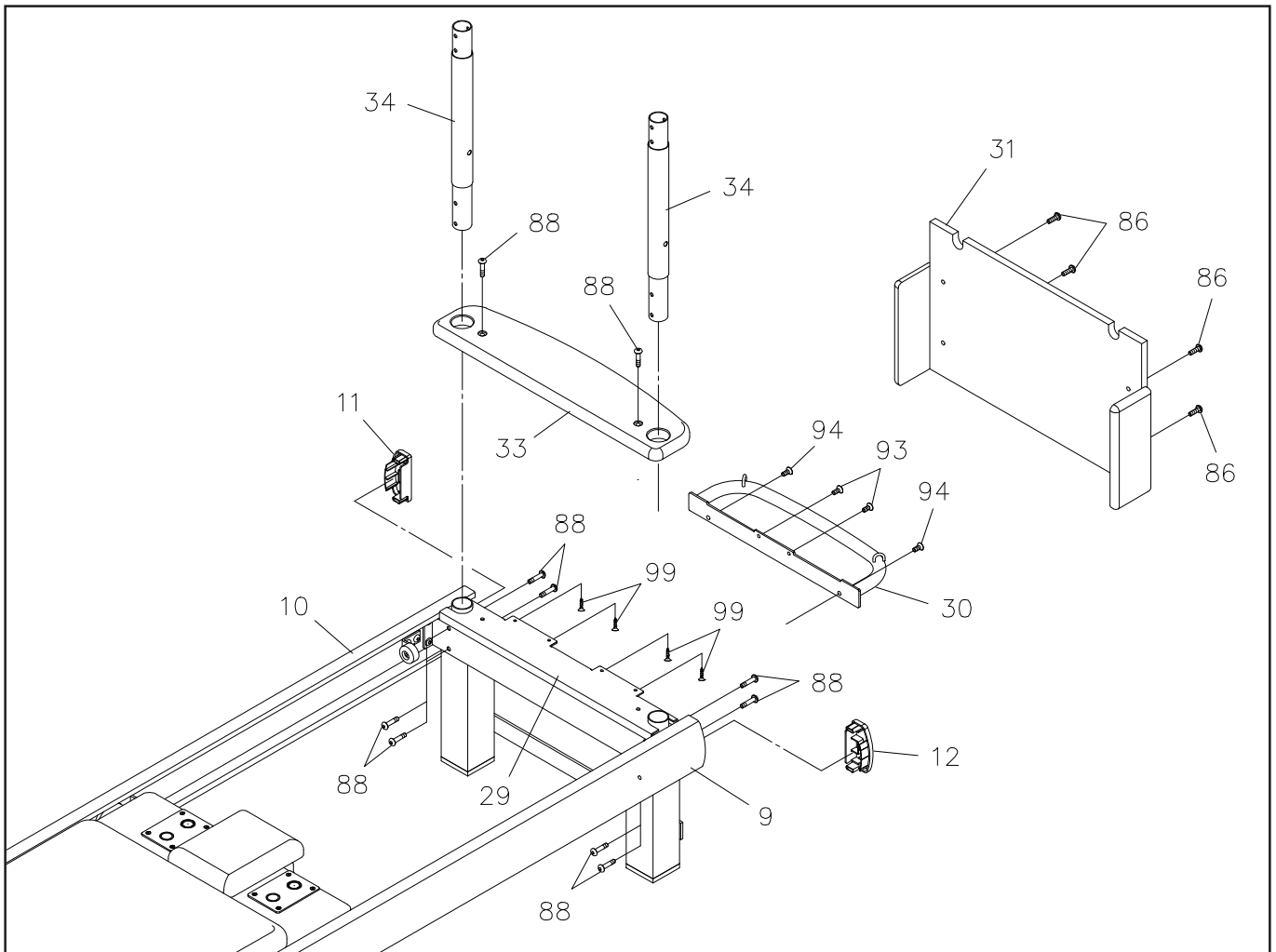

**NOTE:** The **UPRIGHT TUBES(34)** must be installed with the adjustment holes (not shown) facing away from the **AeroPilates® Pro XP686**.

### STEP 9

Attach the **REAR WOODEN PLATFORM(33)** to the **REAR FRAME(29)** with **BUTTON HEAD BOLTS (M8x1.25x35mm)(88)** from the top and **FLAT HEAD SCREWS(M4.5x15mm)(99)** from the bottom.

### STEP 10

Insert the **UPRIGHT TUBES(34)** into the **REAR FRAME(29)** with the series of adjustment holes in the **UPRIGHT TUBES(34)** facing toward the back and secure with **BUTTON HEAD BOLTS(M8x1.25x35mm) (88)**.

### STEP 11

Attach the **HANDRAIL(30)** to the **REAR FRAME(29)** with **FLAT HEAD BOLTS(M6x1x15mm)(93)** and **FLAT HEAD BOLTS(M8x1.25x15mm)(94)**.

### STEP 12

Attach the **REAR WOODEN COVER(31)** to the **REAR FRAME(29)** with **BUTTON HEAD BOLTS (M8x1.25x25mm)(86)**. Press the **LEFT** and **RIGHT RAIL CAPS(11, 12)** into the **LEFT** and **RIGHT RAILS (9, 10)**.

## ASSEMBLY INSTRUCTIONS

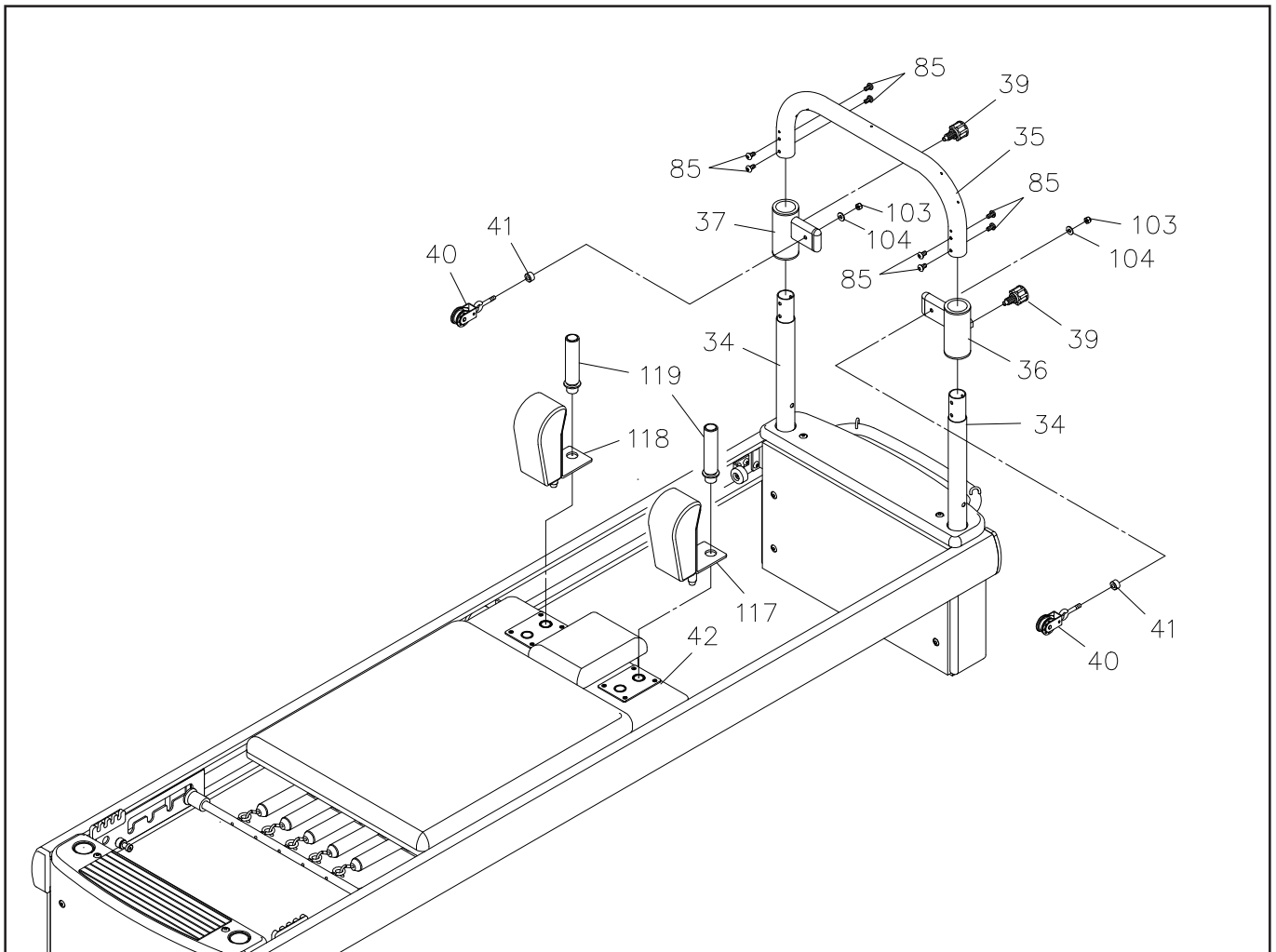

### STEP 13

Slide the **LEFT** and **RIGHT PULLEY SLIDERS**(36, 37) onto the **UPRIGHT TUBES**(34) and lock in position by screwing the **SPRING PINS**(39) into the **PULLEY SLIDERS**(36, 37).

### STEP 14

Insert both ends of the **TOP BEAM**(35) onto the **UPRIGHT TUBES**(34) and secure with **BUTTON HEAD BOLTS**(M8x1.25x15mm)(85).

### STEP 15

Position the **LEFT** and **RIGHT PULLEY SLIDERS**(36, 37) as shown. Slide the **PULLEY SPACERS**(41) onto the **PULLEY SETS**(40) and attach the **PULLEY SETS**(40) to the **LEFT** and **RIGHT PULLEY SLIDERS**(36, 37) with **WASHERS**(M8)(104) and **NYLOCK NUTS**(M8x1.25)(103).

### STEP 16

Attach the shoulder pads to the **CARRIAGE**(42) by inserting the **SHOULDER PAD SUPPORTS**(117, 118) into the holes on the **CARRIAGE**(42) and secure with the **HANDLEBARS**(119).

**NOTE:** The posts on the bottom of the **SHOULDER PAD SUPPORTS**(117, 118) are offset so you can install the supports in two positions. One position is one inch wider to accommodate broader shoulders, another position is for narrower shoulders. To adjust, switch the position of the **SHOULDER PAD SUPPORTS**(117, 118) and secure with the **HANDLEBAR**(119).

## ASSEMBLY INSTRUCTIONS

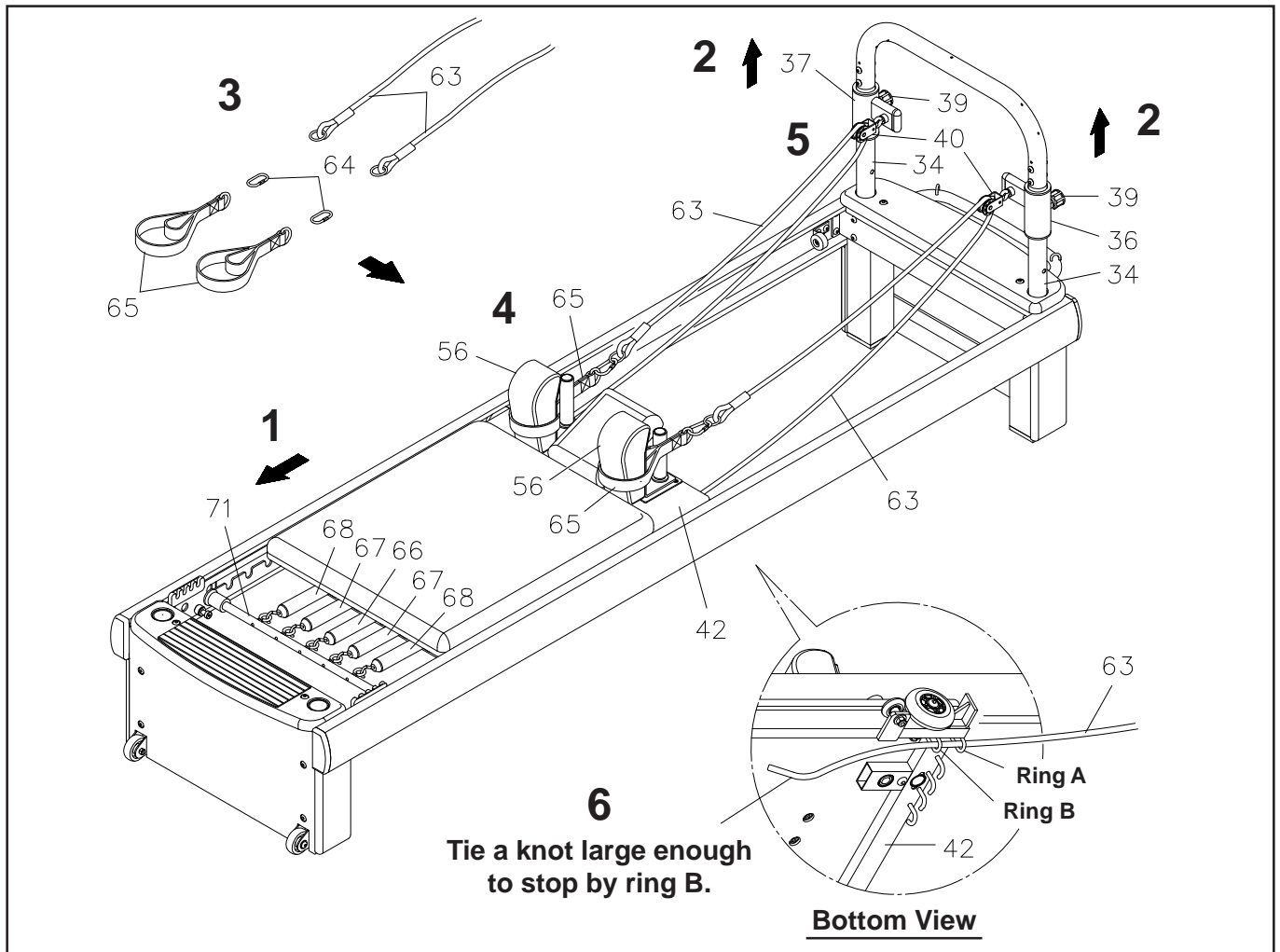

### STEP 17

Assemble the **ROPES(63)** and adjust the length by following these steps:

1. Hook the **TENSION SPRINGS(66, 67, 68)** to the **SPRING BAR(71)**. Adjust the Gear System to move the **SPRING BAR(71)** and **CARRIAGE(42)** to the front-most position. Refer to page 16 for details of Gear System Adjustment.
2. Adjust the **LEFT and RIGHT PULLEY SLIDERS(36, 37)** to the highest position on the **UPRIGHT TUBES (34)**. Refer to page 17 for details of Pulley Slider Adjustment.
3. Attach the **HAND STRAPS(65)** to the looped ends of the **ROPES(63)** with **LINKS(64)**.
4. Loop the **HAND STRAPS(65)** over the **SHOULDER PADS(56)** to hold the ropes in place.
5. Thread the other ends of the **ROPES(63)** through the **PULLEY SETS(40)**.
6. Refer to the bottom view inset in the illustration. Thread the ends of each rope through ring A and ring B on the underside of the **CARRIAGE(42)** and tie a knot in the end of each **ROPE(63)** large enough so the **ROPE(63)** won't pull back through ring B.

- NOTE:**
1. For different workout functions, you will need to change the position of the **SPRING BAR(71)** in the Gear System, or the position of the **PULLY SLIDERS(36, 37)**, you may also need to adjust the **ROPE(63)** length. See Rope Length Adjustment on page 17.
  2. If the **ROPE(63)** is still too long for your workout even when hung on the most distant hook, untie the knot and shorten the **ROPE(63)** by pulling more **ROPE(63)** through ring B. Re-tie and hang on the appropriate hook for proper length.

## ASSEMBLY INSTRUCTIONS

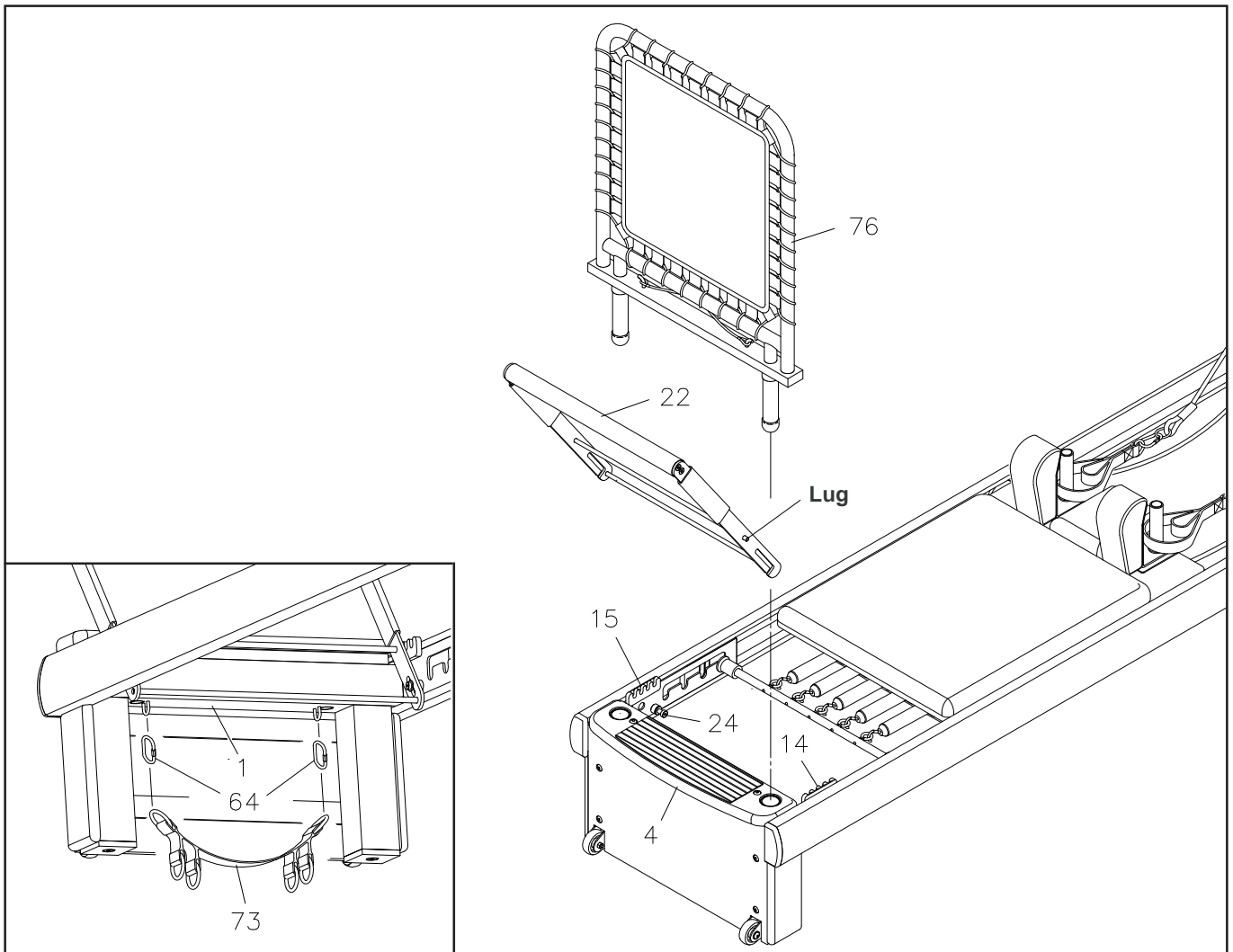

### STEP 18

The **FOOTBAR(22)** and the **CARDIO REBOUNDER(76)** cannot be used at the same time. For cardio workouts, install the **CARDIO REBOUNDER(76)** and for Pilates workouts, install the **FOOTBAR(22)**.

1. **NOTE:** Install the **FOOTBAR(22)** with the slots pointed toward the front as shown. This will keep the **FOOTBAR(22)** in place during adjustment.

To install the **FOOTBAR(22)**, slide the **FOOTBAR(22)** onto the **PIVOT BOLTS(24)** on the **LEFT** and **RIGHT GEAR GUIDES(14, 15)**. Place the lugs on both sides of the **FOOTBAR(22)** into one of the slots on the **LEFT** and **RIGHT GEAR GUIDES(14, 15)**.

2. To install the **CARDIO REBOUNDER(76)**, insert the **CARDIO REBOUNDER(76)** into the two holes in the **FRONT WOODEN PLATFORM(4)**.

### STEP 19

Refer to the inset drawing. Attach the **FOOT STRAP(73)** to the hooks under the **FRONT FRAME(1)** with the **LINKS(64)**.

**NOTE:** There are three D Rings on each end of the **FOOT STRAP(73)**. Use different D Rings to adjust the length of the **FOOT STRAP(73)**.



## SIDE ROLLER ADJUSTMENT

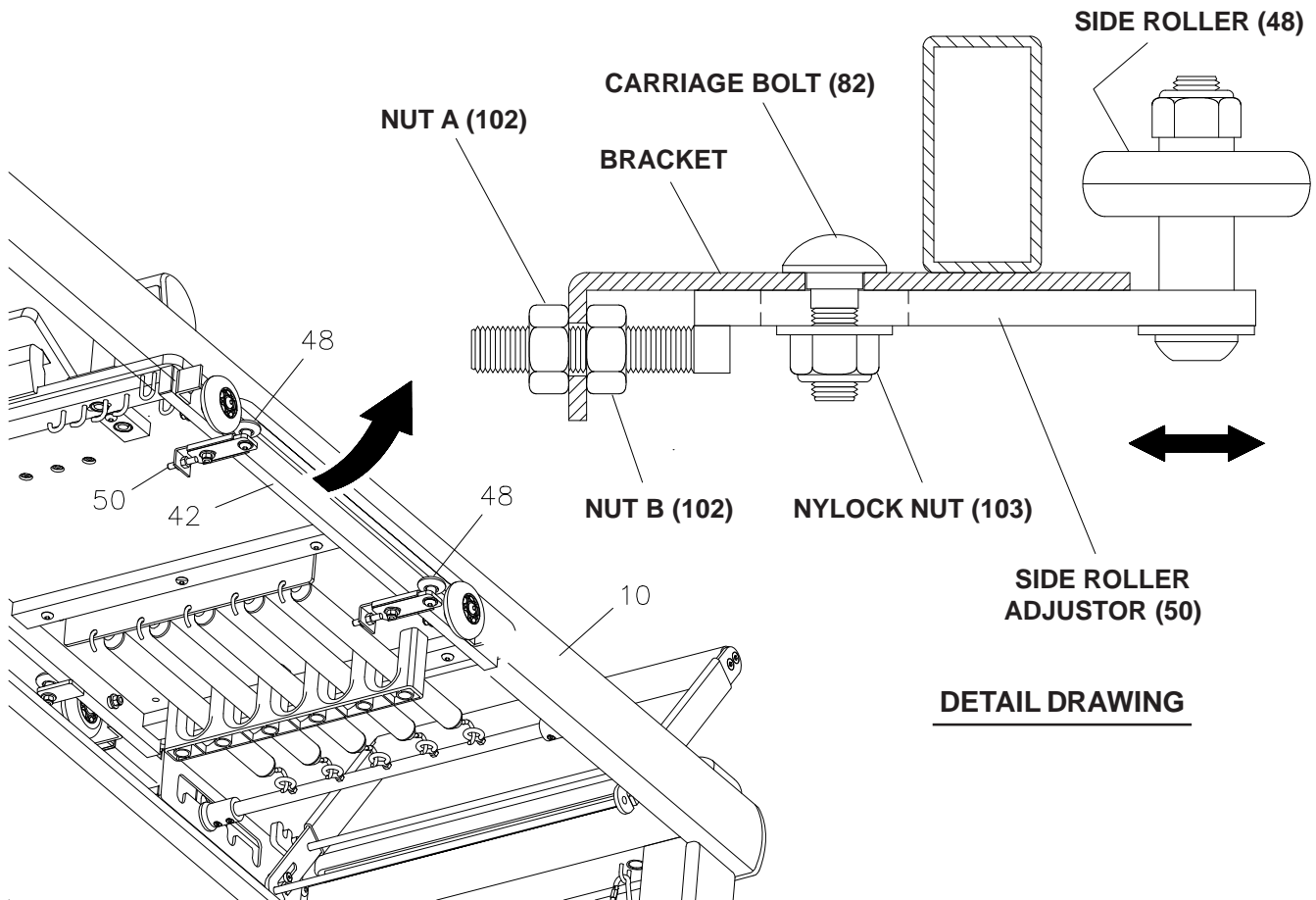

**DETAIL DRAWING**

There are four **SIDE ROLLERS(48)** on the bottom of the **CARRIAGE(42)**. The two **SIDE ROLLERS (48)** on the right side are adjustable. These rollers were preset in the correct position at the factory. If the carriage does not travel smoothly in the rails, the rollers on the right side can be adjusted using the procedure below.

**CARRIAGE IS TOO TIGHT IN THE RAILS** (Refer to the Detail Drawing above.)

1. Loosen the **NYLOCK NUTS(M8x1.25)(103)** on both adjustment assemblies. **Do not** remove the **NYLOCK NUT(M8x1.25)(103)** from the **CARRIAGE BOLT(M8x1.25x18mm)(82)**.
2. On both adjustment assemblies, loosen **NUT B(M8x1.25)(102)** one-half turn. Hold **NUT B(M8x1.25)(102)** and tighten **NUT A(M8x1.25)(102)** securely against the **BRACKET** and **NUT B(M8x1.25)(102)**. Test the **CARRIAGE(42)** to verify that it travels smoothly. Repeat the procedure if necessary.
3. Tighten the **NYLOCK NUTS(M8x1.25)(103)** on both adjustment assemblies.

**CARRIAGE MOVES FROM SIDE TO SIDE IN THE RAILS** (Refer to the Detail Drawing above.)

1. Loosen the **NYLOCK NUTS(M8x1.25)(103)** on both adjustment assemblies. **Do not** remove the **NYLOCK NUT(M8x1.25)(103)** from the **CARRIAGE BOLT(M8x1.25x18mm)(82)**.
2. On both adjustment assemblies, loosen **NUT A(M8x1.25)(102)** one-half turn. Hold **NUT A(M8x1.25)(102)** and tighten **NUT B(M8x1.25)(102)** securely against the **BRACKET** and **NUT A(M8x1.25)(102)**. Test the **CARRIAGE(42)** to verify that it travels smoothly. Repeat the procedure if necessary.
3. Tighten the **NYLOCK NUTS(M8x1.25)(103)** on both adjustment assemblies.

**NOTE:** The **SIDE ROLLER(48)** is adjusted approximately 0.050" (1.25mm) for each complete turn of an adjustment nut.

## OPERATIONAL INSTRUCTIONS

### LOAD ADJUSTMENT

There are three different tension levels for the springs.

- **HIGH TENSION SPRING, RED MARKED(66)**
- **MEDIUM TENSION SPRING, YELLOW MARKED(67)**
- **LOW TENSION SPRING, BLUE MARKED(68)**

The resistance of the **CARRIAGE(42)** can be adjusted by attaching the springs to the **EYEHOOKS(70)** on the **SPRING BAR(71)**. Springs are easily changed between exercises for an uninterrupted workout. The workout wall chart and video workouts recommend how many and which springs to use for each exercise.

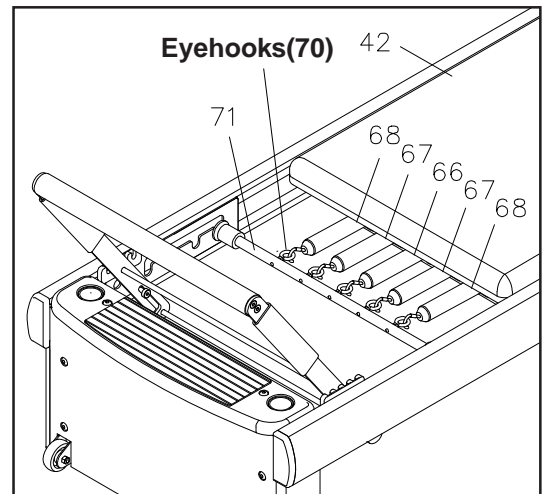

### GEAR SYSTEM

The Gear System allows you to adjust the position of the **CARRIAGE(42)**. The distance between **SHOULDER PADS(56)** and **FOOTBAR(22)** is adjustable to fit different sizes of users or for different workout functions.

- NOTE:**
1. The **CARRIAGE(42)** moves with the **SPRING BAR(71)** during adjustment if the tension springs are attached. The tension springs may be connected or disconnected as desired during the adjustment procedure.
  2. If you change the position of the **SPRING BAR(71)** in the Gear System, you may also need to adjust the **ROPE(63)** length. See Rope Length Adjustment on page 17.

To adjust, lift the **SPRING BAR(71)** so that both ends are in the long upper slot in the **LEFT** and **RIGHT GEAR GUIDES(14, 15)**. Slide the **SPRING BAR(71)** to a new position and insert both ends into the vertical slots in the **LEFT** and **RIGHT GEAR GUIDES(14, 15)** to lock the **SPRING BAR(71)** into position.

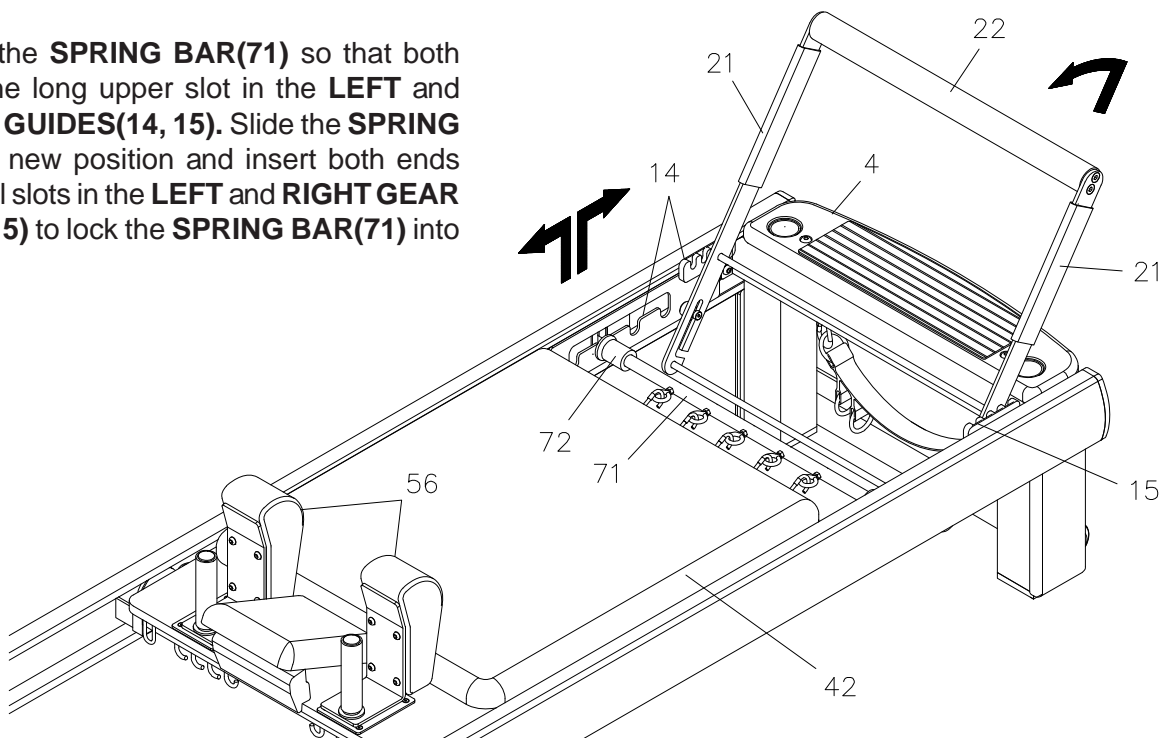

### FOOTBAR ADJUSTMENT

The **FOOTBAR(22)** can be positioned at four angles. Lift the **FOOTBAR(22)** until the lugs come out of the slots on the **LEFT** and **RIGHT GEAR GUIDES(14, 15)**. Move the **FOOTBAR(22)** to the desired position and lock the **FOOTBAR(22)** in position by pushing it down so that the lugs are in the slots on the **LEFT** and **RIGHT GEAR GUIDES(14, 15)**.

- NOTE:**
1. Always make sure the lugs are locked into the slots properly.
  2. Remove the **FOOTBAR(22)** when standing on the cushion with one foot on the **FRONT WOODEN PLATFORM(4)**.

## OPERATIONAL INSTRUCTIONS

### PULLEY SLIDER ADJUSTMENT

There are five adjustment holes in the **UPRIGHT TUBES(34)**. The **LEFT** and **RIGHT PULLEY SLIDERS(36, 37)** can be positioned at different heights. Loosen and pull the **SPRING PINS(39)** to adjust the **PULLEY SLIDERS(36, 37)**. Tighten the knob on the **SPRING PINS(39)** after adjustment.

- NOTE:**
1. The lower outside adjustment holes in the **UPRIGHT TUBES(34)** can be used to move the **PULLEY SLIDERS(36, 37)** out of the way for more clearance between the upright tubes.
  2. If you change the position of the **PULLY SLIDERS(36, 37)**, you may also need to adjust the **ROPE(63)** length.

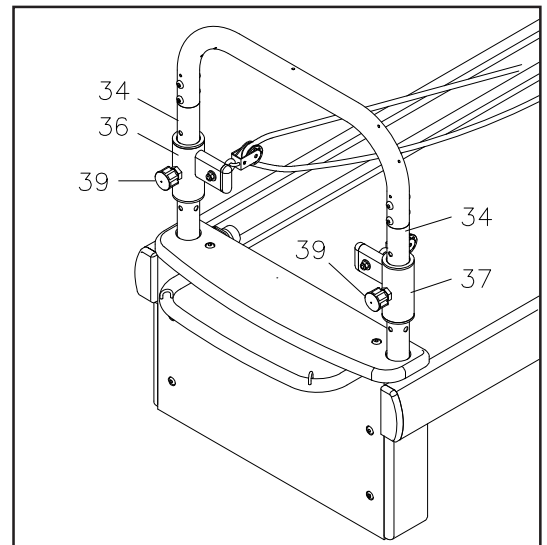

### ROPE LENGTH ADJUSTMENT

You can adjust the length between the **PULLEY SET(40)** and the **HAND STRAP(65)**. Pull the **ROPE(63)** from the gap between ring A and ring B and hang the **ROPE(63)** onto one of the four hooks.

If the **ROPE(63)** is still too long for your workout even when hung on the most distant hook, untie the knot and shorten the **ROPE(63)** by pulling more **ROPE(63)** through ring B. Re-tie and hang on the appropriate hook for proper length.

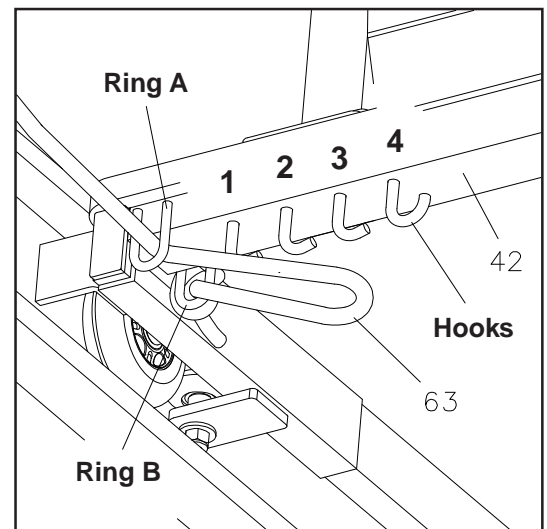

### HEADREST ADJUSTMENT

The **HEADREST(58)** on the **CARRIAGE(42)** can be positioned at three different angles, 0°, 15°, and 22°. Simply pivot the **ANGLE ADJUSTOR(60)** underneath the **HEADREST(58)**.

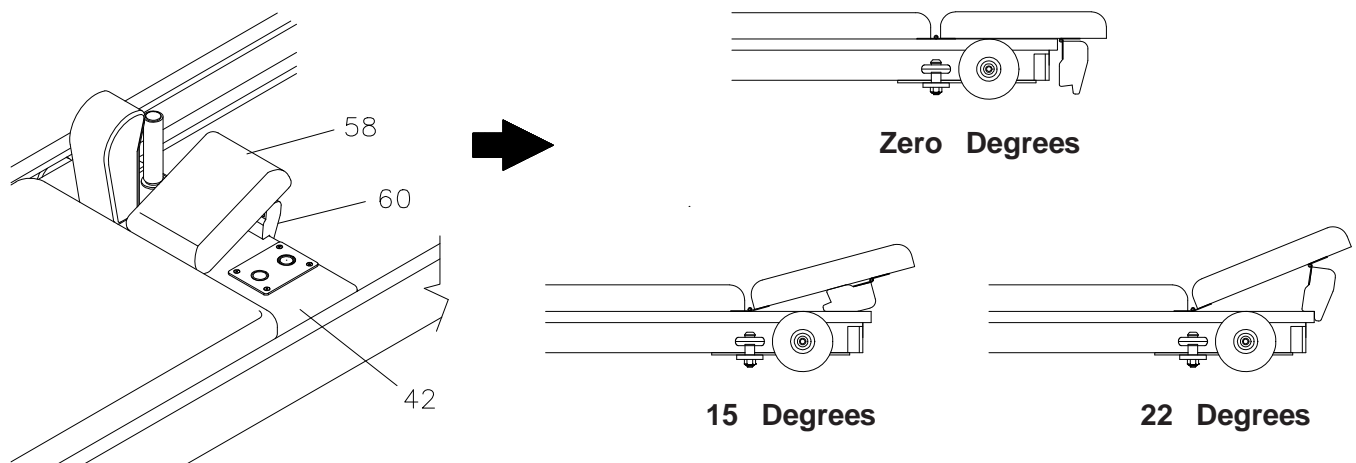

## OPERATIONAL INSTRUCTIONS

### SHOULDER PAD ADJUSTMENT

The posts on the bottom of the **SHOULDER PAD SUPPORTS (117, 118)** are offset so you can install the supports in two positions. One position is one inch wider to accommodate broader shoulders, another position is for narrower shoulders. To adjust, switch the position of the **SHOULDER PAD SUPPORTS(117, 118)** and secure with the **HANDLEBAR (119)**.

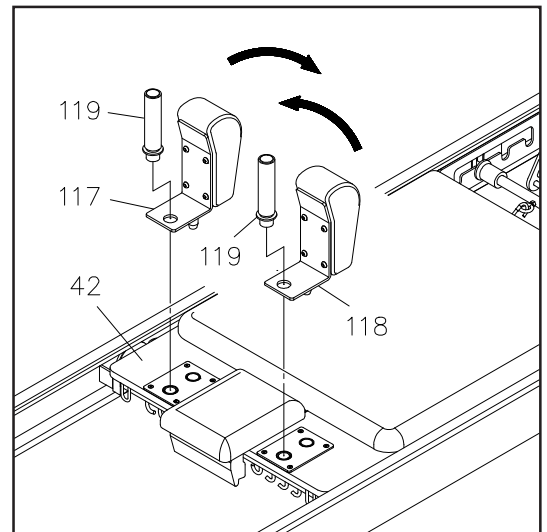

### STORAGE

1. Store the **AeroPilates® Pro XP686** in a clean, dry place.
2. It is recommended that two people be available to move the **AeroPilates® Pro XP686**.
3. To move the **AeroPilates® Pro XP686**: First, attach one of the **TENSION SPRINGS(66, 67 or 68)** to the **EYEHOOK(70)** on the **SPRING BAR(71)** to prevent the **CARRIAGE(42)** from moving. Second, grasp the **HANDRAIL(30)** and lift the unit from the back. Third, roll the **AeroPilates® Pro XP686** on the moving wheels that are attached to the **FRONT FRAME(1)**.

### MAINTENANCE

The safety and integrity designed into the **AeroPilates® Pro XP686** can only be maintained when the **AeroPilates® Pro XP686** is regularly examined for damage and wear. Special attention should be given to the following:

1. It is the sole responsibility of the user/owner to ensure that regular maintenance is performed.
2. Worn or damaged components should be replaced immediately or the **AeroPilates® Pro XP686** removed from service until repair is made.
3. Verify that the Warning Label is present and legible. Replace the Warning Label if it is missing or damaged.
4. Verify that the **ROPES(63)** are properly installed on the **PULLEY SETS(40)**.
5. Check the condition of the **ROPES(63)** and replace if they are frayed or worn.
6. Check the condition of the **TENSION SPRINGS(66, 67, 68)**. Replace the springs that are damaged.
7. Check the **BUNGEE CORD(78)** on the **CARDIO REBOUNDER(76)** for wear. Replace the **CARDIO REBOUNDER(76)** if the **BUNGEE CORD(78)** is frayed or worn.
8. Check the **PULLEY SETS(40)** for excessive wear. Replace worn **PULLEY SETS(40)**.
9. Check the **HAND STRAPS(65)** for damage. Replace damaged parts.
10. Check the **FOAM GRIPS(21)**, **FOAM TUBE(23)**, **SHORT FOAM TUBES(57)**, and **SHOULDER PADS (84)** and replace if damaged or worn.
11. Check the **GUIDE SPACERS(16)** and **BUMPERS(19)** for looseness or damage and replace any damaged parts.
12. Check the **CUSHION(53)** and replace if it is damaged or worn.
13. Check and clean the **ROLLERS(47)** and **SIDE ROLLERS(48)** and the rolling surfaces on the rails. Clean by wiping with a dry cloth.
14. Only Stamina Products supplied components shall be used to maintain/repair the **AeroPilates® Pro XP686**.
15. Keep your **AeroPilates® Pro XP686** clean by wiping with an absorbent cloth after use.

## CONDITIONING GUIDELINES

How you begin your exercise program depends on your physical condition. If you have been inactive for several years or are severely overweight, start slowly and increase your workout time gradually. Increase your workout intensity gradually, too, by monitoring your heart rate while you exercise.

Remember to follow these essentials:

- Have your doctor review your training and diet programs.
- Begin your training program slowly with realistic goals that have been set by you and your physician.
- Warm up before you exercise and cool down after you work out.
- Take your pulse periodically during your workout and strive to stay within a range of 60% (lower intensity) to 90% (higher intensity) of your maximum heart rate zone. Start at the lower intensity and build up to higher intensity as you become more aerobically fit.
- If you feel dizzy or lightheaded you should slow down or stop exercising.

Initially you may only be able to exercise within your target zone for a few minutes; however, your aerobic capacity will improve over the next six to eight weeks. It is important to pace yourself while you exercise so you don't tire too quickly.

To determine if you are working out at the correct intensity, use a heart rate monitor or use the table below. For effective aerobic exercise, your heart rate should be maintained at a level between 60% and 90% of your maximum heart rate. If just starting an exercise program, work out at the low end of your target heart rate zone. As your aerobic capacity improves, gradually increase the intensity of your workout by increasing your heart rate.

Measure your heart rate periodically during your workout by stopping the exercise but continuing to move your legs or walk around. Place two or three fingers on your wrist and take a six second heartbeat count. Multiply the results by ten to find your heart rate. For example, if your six second heartbeat count is 14, your heart rate is 140 beats per minute. A six second count is used because your heart rate will drop rapidly when you stop exercising. Adjust the intensity of your exercise until your heart rate is at the proper level.

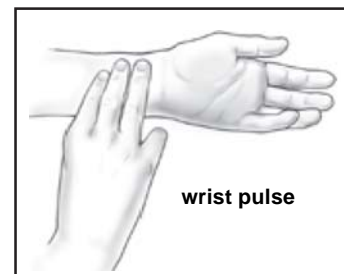

Target Heart Rate Zone Estimated by Age\*

Age	Target Heart Rate Zone (55%-90% of Maximum Heart Rate)	Average Maximum Heart Rate 100%
20 years	110-180 beats per minute	200 beats per minute
25 years	107-175 beats per minute	195 beats per minute
30 years	105-171 beats per minute	190 beats per minute
35 years	102-166 beats per minute	185 beats per minute
40 years	99-162 beats per minute	180 beats per minute
45 years	97-157 beats per minute	175 beats per minute
50 years	94-153 beats per minute	170 beats per minute
55 years	91-148 beats per minute	165 beats per minute
60 years	88-144 beats per minute	160 beats per minute
65 years	85-139 beats per minute	155 beats per minute
70 years	83-135 beats per minute	150 beats per minute

\* For cardiorespiratory training benefits, the American College of Sports Medicine recommends working out within a heart rate range of 55% to 90% of maximum heart rate. To predict the maximum heart rate, the following formula was used:  $220 - \text{Age} = \text{predicted maximum heart rate}$



---

## WARM-UP and COOL-DOWN

**Warm-Up** The purpose of warming up is to prepare your body for exercise and to minimize injuries. Warm up for two to five minutes before strength-training or aerobic exercising. Perform activities that raise your heart rate and warm the working muscles. Activities may include brisk walking, jogging, jumping jacks, jump rope, and running in place

**Stretching** Stretching while your muscles are warm after a proper warm-up and again after your strength or aerobic training session is very important. Muscles stretch more easily at these times because of their elevated temperature, which greatly reduces the risk of injury. Stretches should be held for 15 to 30 seconds. Do not bounce.

### Suggested Stretching Exercises

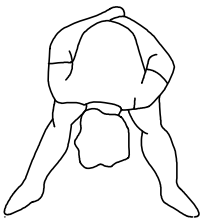

#### Lower Body Stretch

Place feet shoulder width apart and lean forward. Keep this position for 30 seconds using the body as a natural weight to stretch the backs of the legs. **DO NOT BOUNCE!** When the pull on the back of the legs lessen, try a lower position gradually.



#### Floor Stretch

While sitting on the floor, open the legs as wide as possible. Stretch the upper body toward the knee on the right leg by using your arms to pull your chest to your thighs. Hold this stretch 10 to 30 seconds. **DO NOT BOUNCE!** Do this stretch 10 times. Repeat the stretch with the left leg.

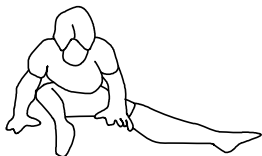

#### Bent Torso Pulls

While sitting on the floor, have legs apart one leg straight and one knee bent. Pull the chest down to touch the thigh on the leg that is bent and twist at the waist. Hold this position at least 10 seconds. Repeat 10 times on each side.

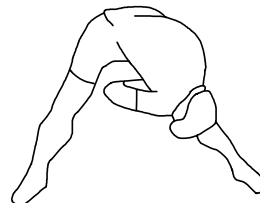
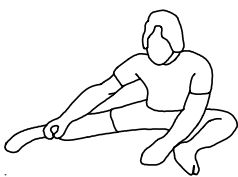

#### Bent Over Leg Stretch

Stand with feet shoulder-width apart and lean forward as illustrated. Using the arms, **gently** pull the upper body towards the right leg. Let the head hang down. **DO NOT BOUNCE!** Hold the position a minimum of 10 seconds. Repeat pulling the upper body to the left leg. Do this stretch several times slowly.

**Remember always to check with your physician before starting any exercise program.**

**Cool-Down** The purpose of cooling down is to return the body to its normal, or near normal, resting state at the end of each exercise session. A proper cool-down slowly lowers your heart rate and allows blood to return to the heart. Your cool-down should include the stretches listed above and should be completed after each strength-training session.



**WARRANTY**

Stamina Products, Inc. warrants that this product will be free from defects in materials and workmanship under normal use, service and proper operation. Limited lifetime warranty: Stamina Products, Inc. will at its option, repair or replace any of the following parts provided that they fail due to a defect in workmanship or materials: Aluminum rails, components of the frame and related welding including the spring retention plate and footbar mechanism. 3 year limited warranty: Stamina Products, Inc. will, at its option, repair or replace springs and cushion assembly rollers. 2 year limited warranty: Stamina Products, Inc. will, at its option, repair or replace any of the parts on the reformer provided that they fail due to a defect in workmanship or materials. 90 day warranty: Stamina Products, Inc. will, at its option, repair or replace the upholstery. Stamina Products, Inc. offers no warranty on labor. **THIS WARRANTY SHALL NOT APPLY TO ANY PRODUCT WHICH HAS BEEN SUBJECT TO ABUSE, MISUSE, ALTERATION OF ANY TYPE OR CAUSE OR TO ANY DEFECT OR DAMAGE CAUSED BY REPAIR, REPLACEMENT, SUBSTITUTION OR USE WITH PARTS OTHER THAN PARTS PROVIDED BY STAMINA PRODUCTS, INC.**

To implement this limited warranty, send a written notice stating your name, date, and place of purchase and a brief description of the defect along with your receipt to **Stamina Products, Inc. P.O. Box 1071, Springfield Missouri, USA, 65801-1071** or call us at **1 (800) 375-7520**. If the defect is covered under this limited warranty, you will be requested to return the product or part to us for free repair or replacement at our option. **NO ACTION FOR BREACH OF THIS LIMITED WARRANTY MAY BE COMMENCED MORE THAN ONE (1) YEAR AFTER THE DATE THE ALLEGED BREACH WAS OR SHOULD HAVE BEEN DISCOVERED. NO ACTION FOR BREACH OF ANY IMPLIED WARRANTY MAY BE COMMENCED MORE THAN ONE (1) YEAR AFTER DELIVERY OF THE PRODUCT TO THE PURCHASER.** This limited warranty is not transferable. **IF ANY PART OF THE PRODUCT IS NOT IN COMPLIANCE WITH THIS LIMITED WARRANTY OR ANY IMPLIED WARRANTY, THE REMEDY OF REPAIR OR REPLACEMENT IS THE EXCLUSIVE REMEDY AVAILABLE TO YOU.** In the event that the purchaser makes any claim under this limited warranty or any implied warranty, the Warrantor reserves the right to require the product to be returned for inspection, at the purchaser's expense, to the Warrantor's premises in Springfield, Missouri. Return of the enclosed warranty registration card is not required for warranty coverage, but is merely a way of establishing the date and place of purchase.

Stamina Products, Inc. **SHALL NOT BE LIABLE FOR THE LOSS OF USE OF ANY PRODUCT, LOSS OF TIME, INCONVENIENCE, COMMERCIAL LOSS OR ANY OTHER INDIRECT, CONSEQUENTIAL, SPECIAL OR INCIDENTAL DAMAGES DUE TO BREACH OF THE ABOVE WARRANTY OR ANY IMPLIED WARRANTY.**

This limited warranty is the only written or express warranty given by Stamina Products, Inc. This warranty gives you specific legal rights, and you may also have other legal rights which vary from state to state. **ANY OTHER RIGHT WHICH YOU MAY HAVE, INCLUDING ANY IMPLIED WARRANTY OR MERCHANTABILITY OR FITNESS FOR A PARTICULAR PURPOSE, IS LIMITED IN DURATION TO THE DURATION OF THIS WARRANTY.**

The laws in some jurisdictions restrict the rights of manufacturers and distributors of consumer goods to disclaim or limit implied warranties and consequential and incidental damages with respect thereto. If any such law is found to be applicable, the foregoing disclaimers and limitations of and on implied warranties and consequential and incidental damages with respect thereto shall be disregarded and shall be deemed not to have been made to the extent necessary to comply with such legal restriction.

# PRODUCT PARTS DRAWING

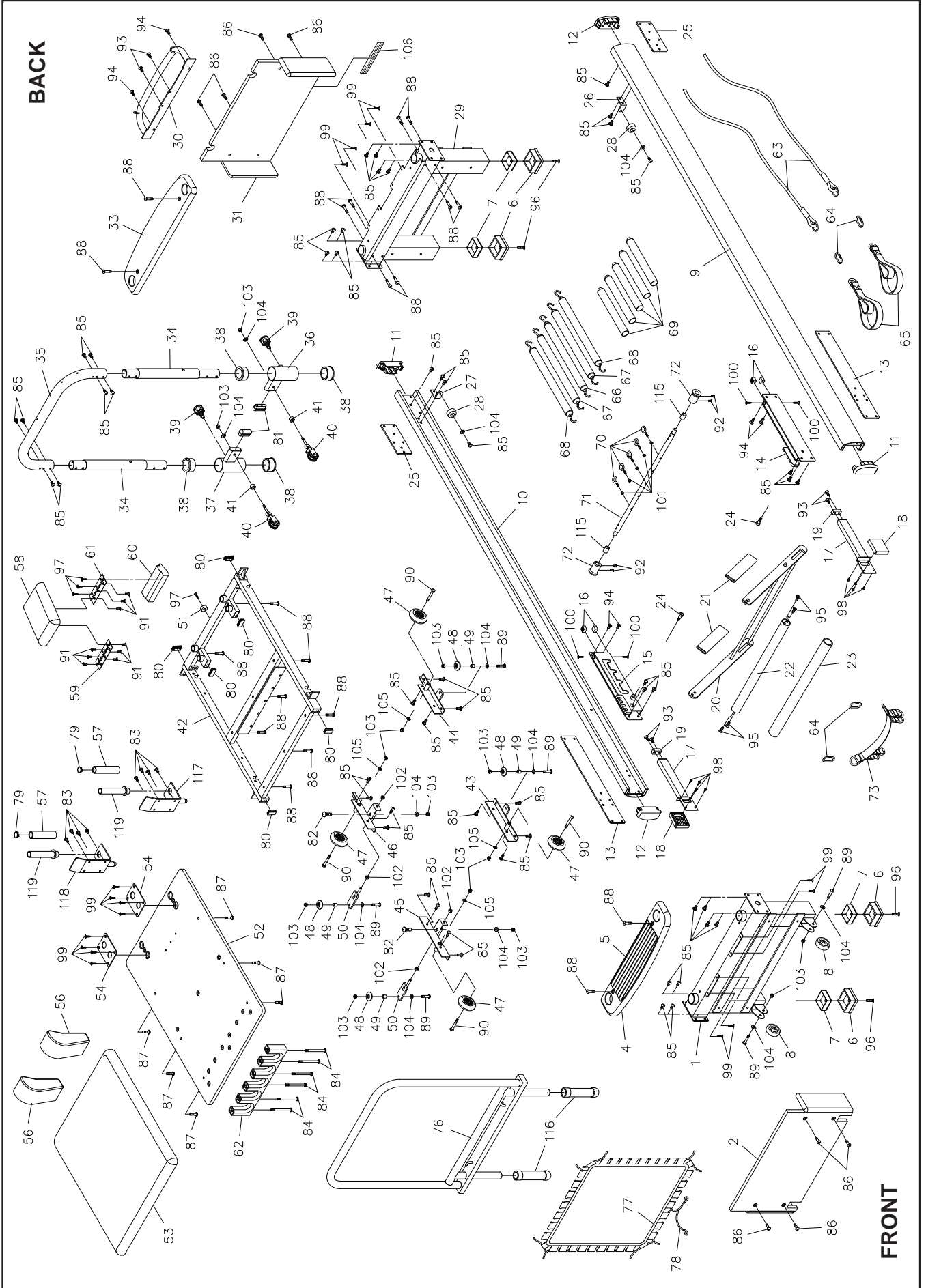

---

## PARTS LIST

DIAGRAM#	PART NAME	QTY
1	Front Frame	1
2	Front Wooden Cover	1
4	Front Wooden Platform	1
5	Foot Pad	1
6	Stand Cap	4
7	Support Cap	4
8	Wheel	2
9	Left Rail	1
10	Right Rail	1
11	Left Rail Cap	2
12	Right Rail Cap	2
13	Front Support plate	2
14	Left Gear Guide	1
15	Right Gear Guide	1
16	Guide Spacer	4
17	Bumper Slider	2
18	Slider Block	2
19	Bumper	2
20	Footbar Support	1
21	Foam Grip	2
22	Footbar	1
23	Foam Tube	1
24	Pivot Bolt (M8 x 1.25)	2
25	Rear Support Plate	2
26	Left Bumper Bracket	1
27	Right Bumper Bracket	1
28	Round Bumper	2
29	Rear Frame	1
30	Handrail	1
31	Rear Wooden Cover	1
33	Rear Wooden Platform	1
34	Upright Tube	2
35	Top Beam	1
36	Left Pulley Slider	1
37	Right Pulley Slider	1
38	Slider Bushing	4
39	Spring Pin	2
40	Pulley Set	2
41	Pulley Spacer	2
42	Carriage	1
43	Front Roller Bracket	1
44	Rear Roller Bracket	1
45	Front Adjustable Roller Bracket	1
46	Rear Adjustable Roller Bracket	1
47	Roller	4
48	Side Roller	4
49	Side Roller Spacer	4
50	Side Roller Adjustor	2
51	Protect Bumper	1

## PARTS LIST

DIAGRAM#	PART NAME	QTY
52	Carriage Board	1
53	Cushion	1
54	Protect Plate	2
56	Shoulder Pad	2
57	Short Foam Tube	2
58	Headrest	1
59	Headrest Hinge	1
60	Angle Adjustor	1
61	Angle Adjustor Hinge	1
62	Spring Holder	1
63	Rope	2
64	Link	4
65	Hand Strap	2
66	High Tension Spring, Red Marked	1
67	Medium Tension Spring, Yellow Marked	2
68	Low Tension Spring, Blue Marked	2
69	Tension Spring Sleeve	5
70	Eyehook	5
71	Spring Bar	1
72	Sleeve	2
73	Foot Strap	1
76	Cardio Rebounder	1
77	Cardio Rebounder Mat	1
78	Bungee Cord	1
79	Round Plug (25.4mm)	2
80	Rectangular Plug (20mm x 40mm)	6
81	Oval Plug (20mm x 60mm)	2
82	Carriage Bolt (M8 x 1.25 x 18mm)	2
83	Bolt, Button Head (M6 x 1 x 20mm)	8
84	Bolt, Button Head (M6 x 1 x 82mm)	6
85	Bolt, Button Head (M8 x 1.25 x 15mm)	54
86	Bolt, Button Head (M8 x 1.25 x 25mm)	8
87	Bolt, Button Head (M8 x 1.25 x 30mm)	6
88	Bolt, Button Head (M8 x 1.25 x 35mm)	20
89	Bolt, Button Head (M8 x 1.25 x 42mm)	6
90	Bolt, Button Head (M8 x 1.25 x 75mm)	4
91	Bolt, Flat Head (M5 x 0.8 x 15mm)	9
92	Bolt, Flat Head (M5 x 0.8 x 20mm)	4
93	Bolt, Flat Head (M6 x 1 x 15mm)	6
94	Bolt, Flat Head (M8 x 1.25 x 15mm)	6
95	Bolt, Flat Head (M8 x 1.25 x 18mm)	4
96	Bolt, Flat Head (M10 x 1.5 x 42mm)	4
97	Screw, Round Head (M5 x 20mm)	4
98	Screw, Flat Head (M4 x 15mm)	8
99	Screw, Flat Head (M4.5 x 15mm)	16
100	Screw, Flat Head (M6 x 12mm)	4
101	Nut (M6 x 1)	5
102	Nut (M8 x 1.25)	4
103	Nylock Nut (M8 x 1.25)	14

---

## PARTS LIST

DIAGRAM#	PART NAME	QTY
104	Washer (M8)	12
105	Lock Washer (M8)	4
106	Warning Label	1
107	Combination Wrench	1
108	Allen Wrench (4mm)	1
109	Allen Wrench (5mm)	1
110	Allen Wrench (6mm)	1
111	Manual	1
112	Workout Chart	1
113	AeroPilates Level 1 Workout (DVD)	1
114	AeroPilates Cardio Workout (DVD)	1
115	Bumper Bushing	2
116	Bumper Sleeve	2
117	Shoulder Pad Support A	1
118	Shoulder Pad Support B	1
119	Handlebar	2

---

## NOTES





## Free Manuals Download Website

<http://myh66.com>

<http://usermanuals.us>

<http://www.somanuals.com>

<http://www.4manuals.cc>

<http://www.manual-lib.com>

<http://www.404manual.com>

<http://www.luxmanual.com>

<http://aubethermostatmanual.com>

Golf course search by state

<http://golfingnear.com>

Email search by domain

<http://emailbydomain.com>

Auto manuals search

<http://auto.somanuals.com>

TV manuals search

<http://tv.somanuals.com>