

Space **MATE**[®] **FOLDING STEPPER**

Owner's Manual

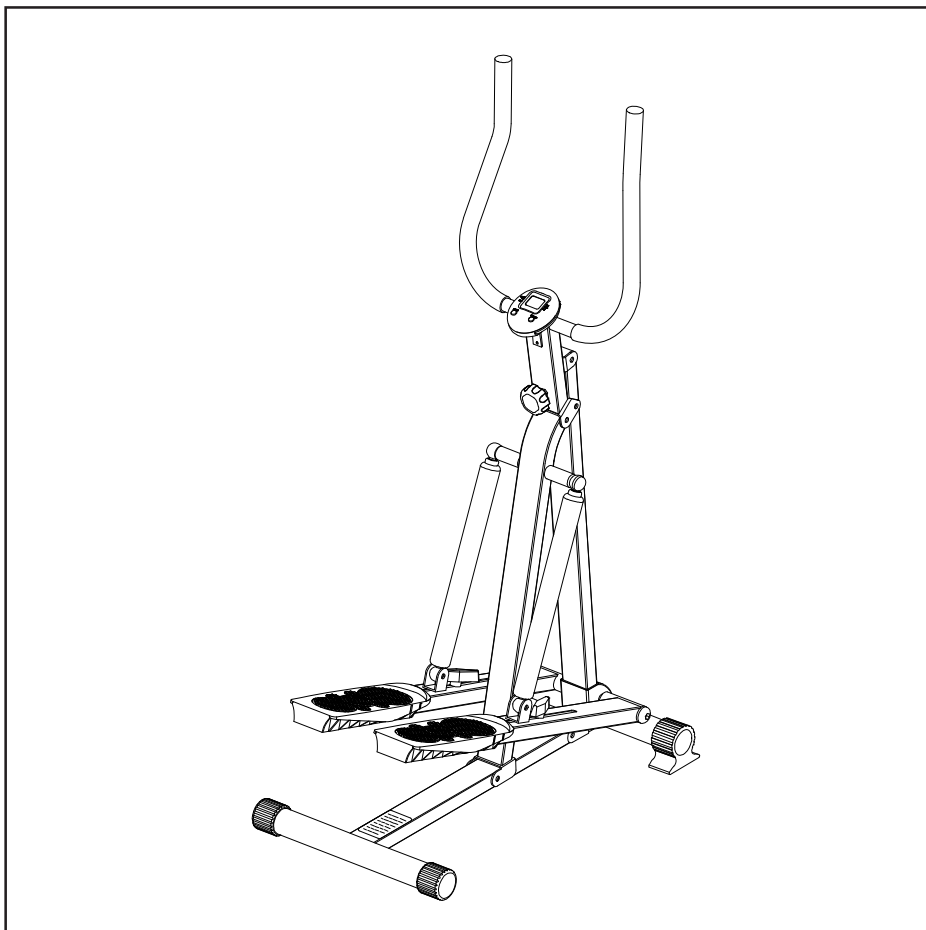

! WARNING !

Exercise can present a health risk. Consult a physician before beginning any exercise program with this equipment. If you feel faint or dizzy, immediately discontinue use of this equipment. Serious bodily injury can occur if this equipment is not assembled and used correctly. Serious bodily injury can also occur if all instructions are not followed. Keep others and pets away from equipment when in use. Always make sure all bolts and nuts are tightened prior to each use. Follow all safety instructions in this manual.

When calling for parts or service, please specify the following number.

40-0069

PATENT NO. 6,387,014 B2

MADE IN CHINA

**Product May Vary Slightly
From Pictured.**

CAUTION:

Weight on this product should not exceed 250 lbs.

This Product is Produced Exclusively by



2040 N. Alliance, Springfield, MO 65803

Customer Service Number

1 (800) 375-7520

www.staminaproducts.com

TABLE OF CONTENTS

	Page		Page
Safety Instructions	2	Conditioning Guidelines	11
Before You Begin	4	Warm-up and Cool-Down	12
Hardware Identification Chart	5	Warranty	13
Assembly Instructions	6	Product Parts Drawing	14
Electronics Instructions	8	Parts List	15
Operational Instructions	9	Notes	16
Maintenance	9	Fax/Mail Ordering Form	18
Storage	10		

SAFETY INSTRUCTIONS

WARNING: To reduce the risk of serious injury, read the following Safety Instructions before using the **Space Mate Folding Stepper**.

1. Read all warnings posted on the **Space Mate Folding Stepper**.
2. Read this Owner's Manual and follow it carefully before using the **Space Mate Folding Stepper**. Make sure that it is properly assembled and tightened before use.
3. Keep children away from the **Space Mate Folding Stepper**. Do not allow children to use or play on the **Space Mate Folding Stepper**. Keep children and pets away from the **Space Mate Folding Stepper** when it is in use.
4. It is recommended that you place this exercise equipment on an equipment mat.
5. Set up and operate the **Space Mate Folding Stepper** on a solid level surface. Do not position the **Space Mate Folding Stepper** on loose rugs or uneven surfaces.
6. Inspect the **Space Mate Folding Stepper** for worn or loose components prior to use. Tighten/replace any loose or worn components prior to using.
7. Shocks on steppers get **HOT** during use. To avoid burns, do not touch the shocks until they have time to cool.
8. Tighten the T KNOBS securely before using the **Space Mate Folding Stepper**.
9. Consult a physician prior to commencing an exercise program. If, at any time during exercise, you feel faint, dizzy, or experience pain, stop and consult your physician.
10. Follow your physician's recommendations in developing your own personal fitness program.
11. Always choose the workout which best fits your physical strength and flexibility level. Know your limits and train within them. Always use common sense when exercising.
12. Do not wear loose or dangling clothing while using the **Space Mate Folding Stepper**.
13. Never exercise in bare feet or socks; always wear correct footwear, such as running, walking, or crosstraining shoes. Be sure that they fit well, provide foot support and feature non-skid rubber soles.
14. Care should be taken in mounting or dismounting the **Space Mate Folding Stepper**.
15. The **Space Mate Folding Stepper** should not be used by persons weighing over 250 pounds.
16. The **Space Mate Folding Stepper** should be used by only one person at a time.
17. When folding or unfolding the **Space Mate Folding Stepper**, keep all children away from the **Space Mate Folding Stepper** and make sure your hands are clear of any folding or pinch point.
18. The **Space Mate Folding Stepper** is for consumer use only. It is not for use in public or semipublic facilities.

WARNING: Before starting any exercise or conditioning program you should consult with your personal physician to see if you require a complete physical exam. This is especially important if you are over the age of 35, have never exercised before, are pregnant, or suffer from any illness. **READ AND FOLLOW THE SAFETY PRECAUTIONS. FAILURE TO FOLLOW THESE INSTRUCTIONS CAN RESULT IN SERIOUS BODILY INJURY.**

CALL US FIRST



**CUSTOMER SERVICE NUMBER
1 (800) 375-7520**

**THANK YOU FOR PURCHASING THE
Space Mate Folding Stepper**

To help you get started, we have pre-assembled most of your Space Mate Folding Stepper at the factory with the exception of those few parts left unassembled for shipping purposes. Simply follow the few assembly instructions set forth in this manual. Within a few minutes you will be getting your body into shape and on your way to achieving a happier and healthier lifestyle.

Should you have any questions,
please call our Customer Service Department toll-free number,
1 (800) 375-7520
Monday - Friday, 8:00 A.M. - 5:00 P.M., Central Time.

BEFORE YOU BEGIN

Thank you for choosing the **Space Mate Folding Stepper**. We take great pride in producing this quality product and hope it will provide many hours of quality exercise to make you feel better, look better and enjoy life to its fullest.

Yes, it's a proven fact that a regular exercise program can improve your physical and mental health. Too often, our busy lifestyles limit our time and opportunity to exercise. The **Space Mate Folding Stepper** provides a convenient and simple method to begin your assault on getting your body in shape and achieving a happier and healthier lifestyle.

Before reading further, please review the drawing below and familiarize yourself with the parts that are labeled.

Read this manual carefully before using the **Space Mate Folding Stepper**.

Although Stamina tries to manufacture its products with the finest materials and uses the highest standards of manufacturing, occasionally a part that does not fit, is the incorrect size, or is otherwise inappropriate is found. Even with the highest inspection and quality controls in place these things will happen occasionally. Please do not return the product. For your convenience, Stamina has a Customer Service Department with a toll-free number. If a part is missing, does not fit, is the incorrect size, or is otherwise inappropriate, please call 1 (800) 375-7520 (in the U.S.) between 8:00 A.M. and 5:00 P.M. Central Time, Monday through Friday. Our operators will be able to assist you with your problem and the parts will be mailed directly to your house.

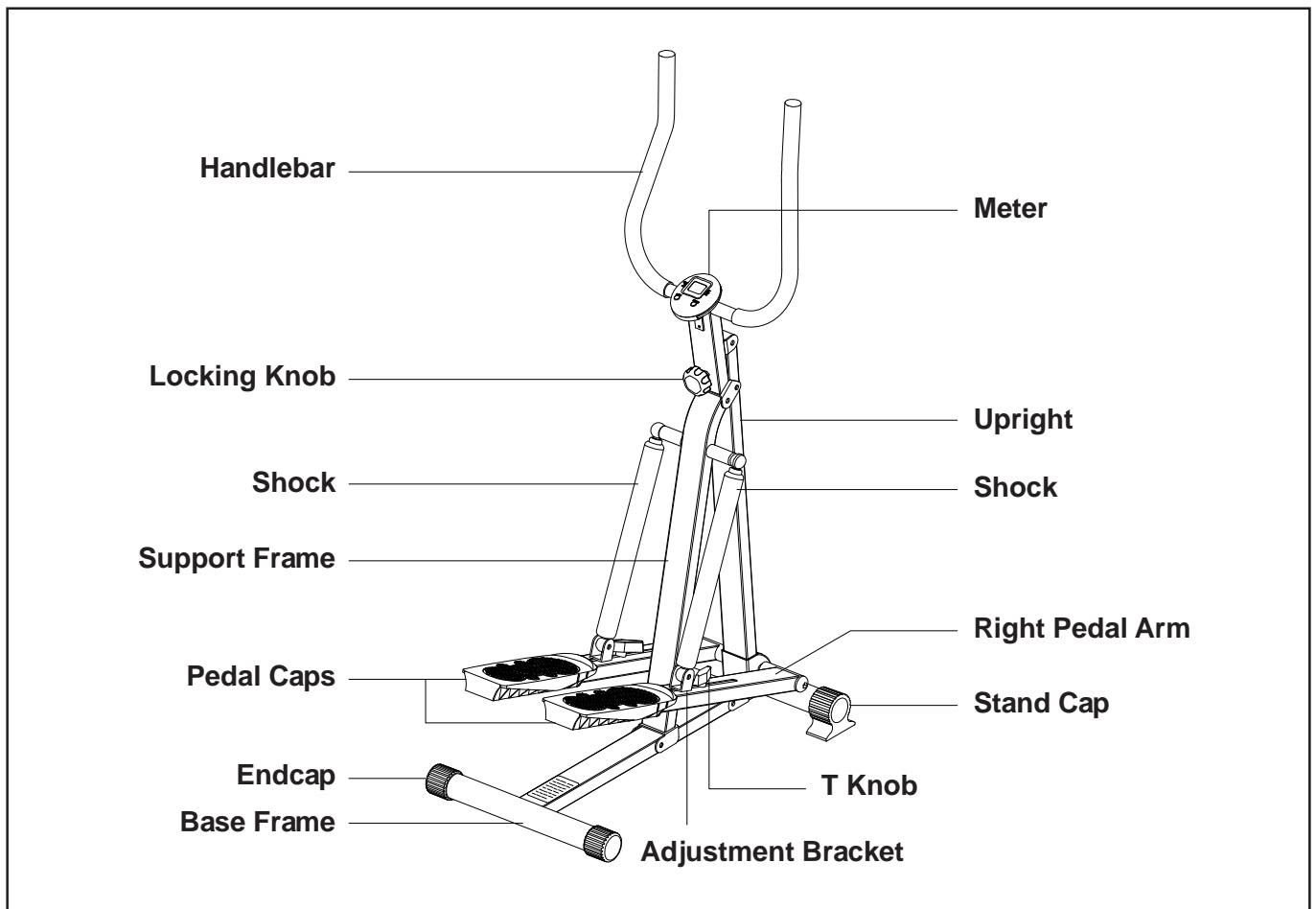

THE FOLLOWING TOOLS ARE REQUIRED FOR ASSEMBLY :

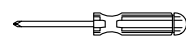

Phillips Screwdriver

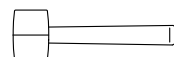

Rubber Mallet

HARDWARE IDENTIFICATION CHART

This chart is provided to help identify the hardware used in the assembly process. After unpacking the unit, open the hardware bag and make sure that you have the following items:

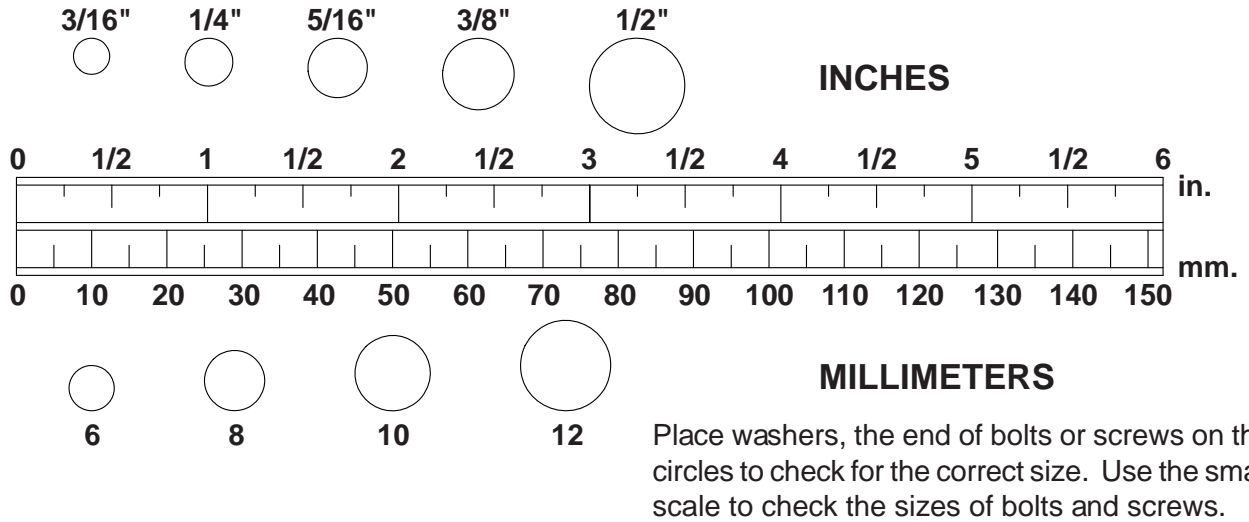

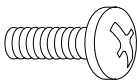
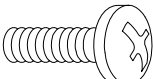
	Part No. and Description	Qty
	33 Screw, Round Head (M5 x 0.8 x 15mm)	2
	35 Bolt, Round Head (M6 x 1 x 20mm)	1

NOTE: Some of the hardware items listed may be attached to other parts.

ASSEMBLY INSTRUCTIONS

Place all parts from the box in a cleared area and position them on the floor in front of you. Remove all packing materials from your area and place them back into the box. Do not dispose of the packing materials until assembly is completed. Read each step carefully before beginning. If you are missing a part please call our toll-free number for assistance **1 (800) 375-7520** or e-mail us at: **parts@staminaproducts.com**

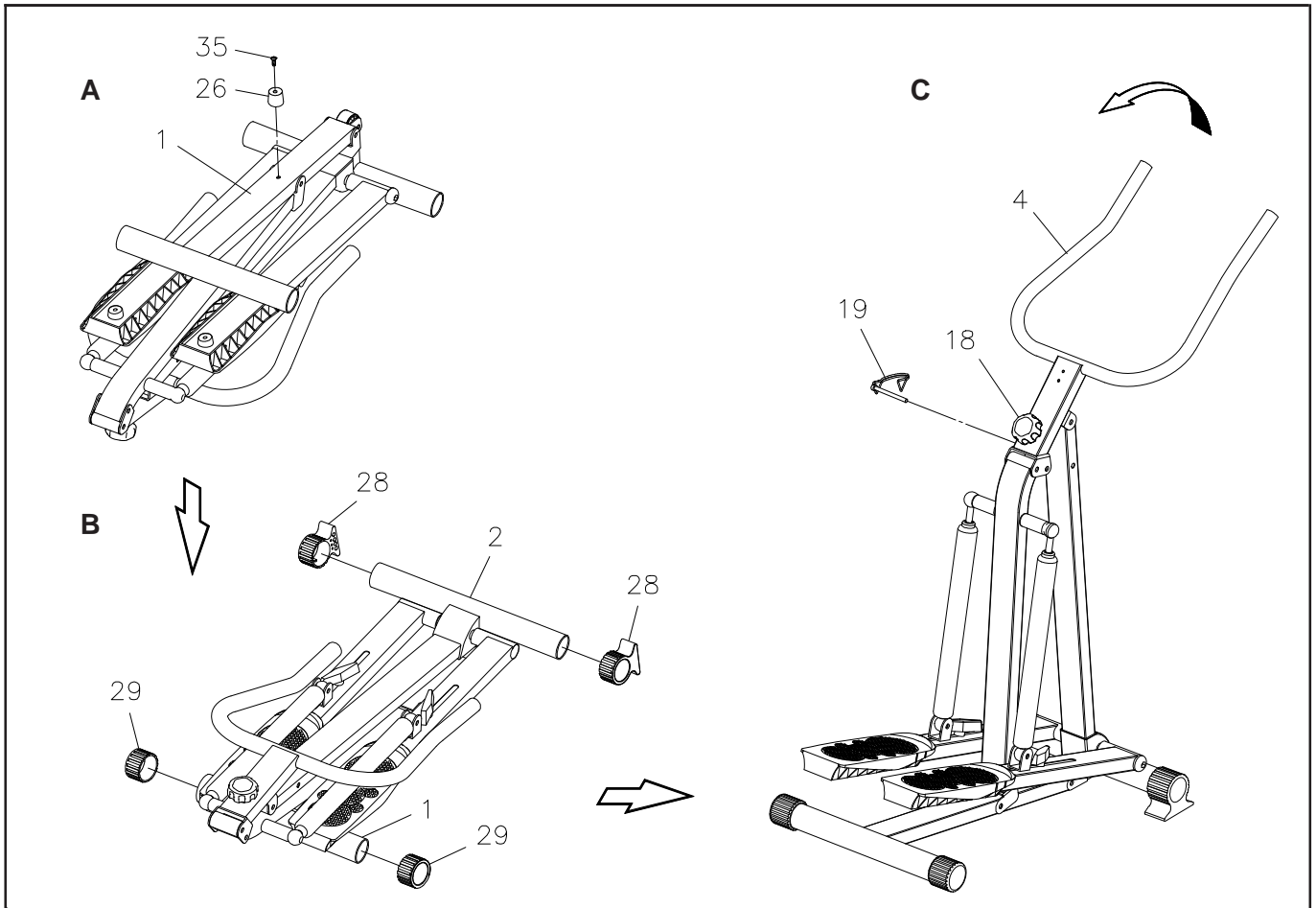

STEP 1

Lay the **STEPPER** on the floor as shown in the illustration **A**. Attach the **BASE STAND(26)** onto the **BASE FRAME(1)** with **ROUND HEAD BOLT(M6 x 20mm)(35)**.

STEP 2

Turn the **STEPPER** to other side as shown in illustration **B**. Press the **ENDCAPS(29)** onto bother sides of the **BASE FRAME(1)**. Refer to illustration **B** and make sure the Key Rib in the **STAND CAPS(28)** align with the slot in the Stabilizer of the **UPRIGHT(2)**. Then press the **STAND CAPS(28)** onto both sides of the **UPRIGHT(2)**.

STEP 3

Refer to illustration **C**. Raise the **STEPPER** to an upright position and unfold the **STEPPER** by lifting the **HANDLEBAR(4)**. Lock the **HANDLEBAR(4)** to the **UPRIGHT(2)** with the **LOCKING KNOB(18)** and insert the **LOCKING PIN(19)** through the Bracket on the **HANDLEBAR(4)** and the **UPRIGHT(2)**.

WARNING: When folding and unfolding the **Space Mate Folding Stepper**, keep all children away from the **Space Mate Folding Stepper** and make sure your hands are clear of any folding or pinch point.

ASSEMBLY INSTRUCTIONS

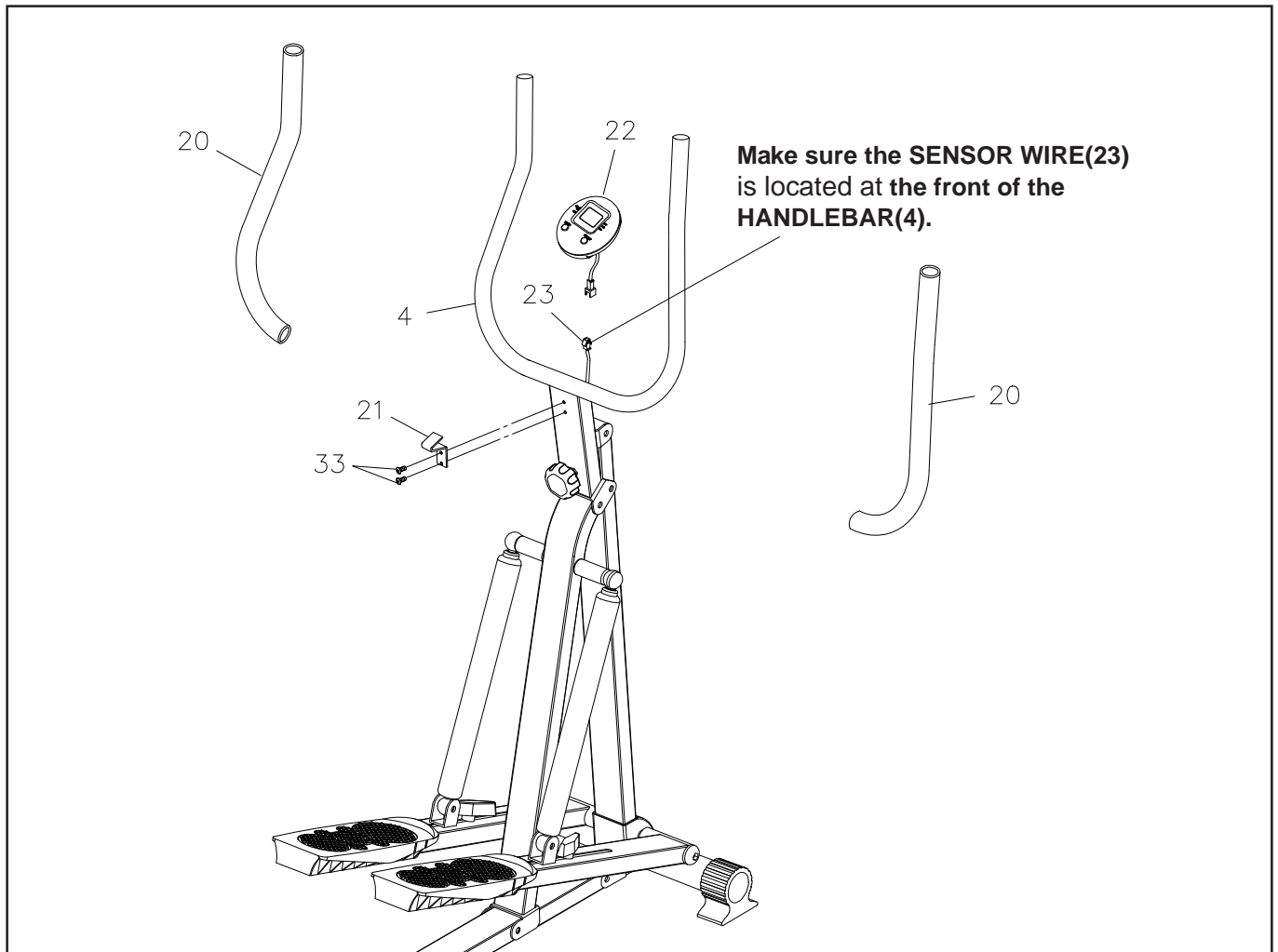

STEP 4

For easier installation of the **FOAM GRIPS(20)**, lubricate the **HANDLEBAR(4)** with a small amount of liquid soap. Slide the **FOAM GRIPS(20)** onto the **HANDLEBAR(4)**.

STEP 5

Attach the **MOUNTING BRACKET(21)** onto the **HANDLEBAR(4)** with **ROUND HEAD SCREWS (M5 x 15mm)(33)**.

STEP 6

Install an "AA" battery into the **METER(22)**, one battery included. See page 8 for detailed battery installation instructions. Slide the **METER(22)** onto the **MOUNTING BRACKET(21)**. Make sure the **SENSOR WIRE(23)** is located at the front of the **HANDLEBAR(4)**, then plug the **SENSOR WIRE(23)** into the **METER(22)**.

USING THE ELECTRONIC METER

POWER ON : Pedal movement or push any button.

POWER OFF : Automatic shut off after 4 minutes of inactivity.

FUNCTION BUTTONS:

MODE : Push to select the function of the lower readout.

RESET : To reset all functions to zero.

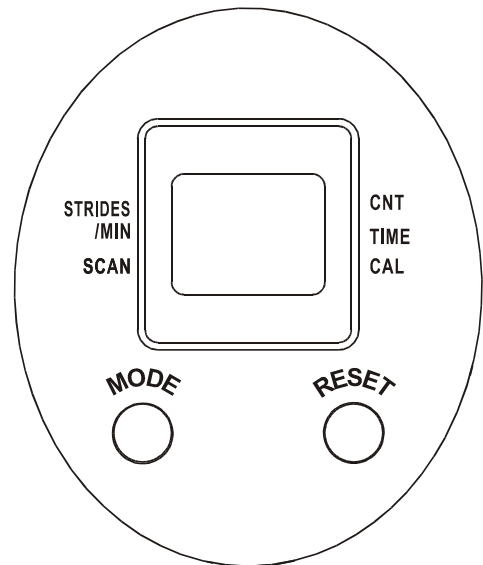

FUNCTIONS:

SCAN: Automatically scans each function of **TIME**, **CALORIE**, **STRIDES/MIN** in sequence with change every 6 seconds.

COUNT : Upper readout displays the total number of strides you have taken, from zero to 9999 strides.

TIME: Displays the riding time, from 1 sec up to 99:59 minutes.

STRIDES/MIN: Displays the rate of strides per minute.

CALORIE: Displays the calorie consumption, from zero to 9999 cal.

The calorie readout is an estimate for an average user. It should be used only as a comparison between workouts on this unit.

How to Install and Replace Battery:

1. Open the Battery Door on the back of the meter.
2. The meter operates with an AA battery. Refer to the illustration to install or replace the battery.

Note:

1. Rechargeable batteries are not recommended.

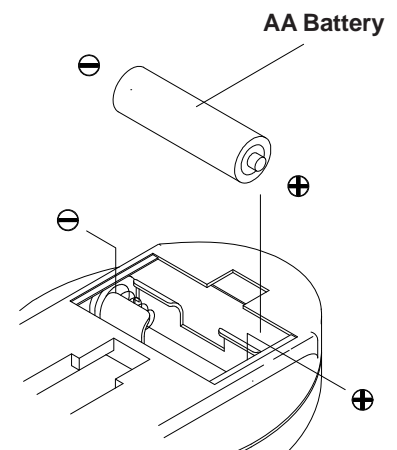

OPERATIONAL INSTRUCTIONS

ADJUSTING RESISTANCE

The resistance of the shocks can be adjusted by sliding the **SHOCK ADJUSTMENTS** in the slot on the **PEDAL ARMS(5, 6)**. Position the **SHOCK ADJUSTMENTS** at the front end of the slot to provide the lowest resistance and the fastest workout pace. Position the **SHOCK ADJUSTMENTS** at the back end of the slot to provide the highest resistance and the slowest workout pace.

CAUTION:

1. The shocks get **HOT** after a few minutes of use.
2. Tighten the **T KNOBS** securely before using the **Space Mate Folding Stepper**

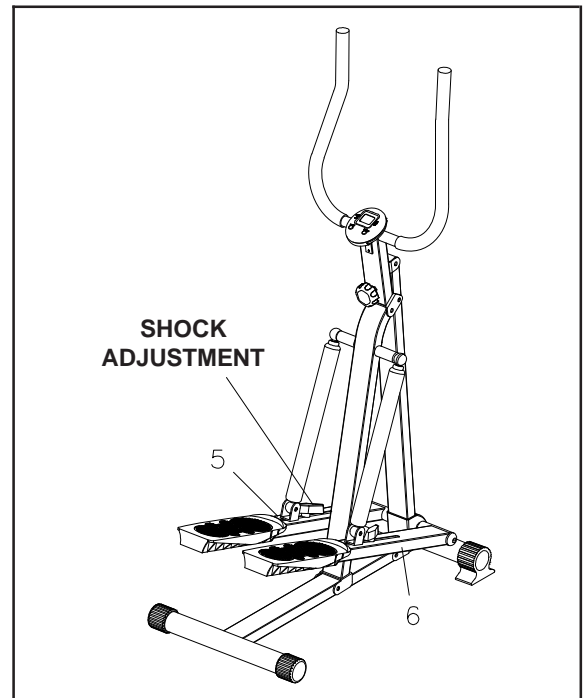

MAINTENANCE

The safety and integrity designed into the **Space Mate Folding Stepper** can only be maintained when the **Space Mate Folding Stepper** is regularly examined for damage and wear. Special attention should be given to the following:

1. Verify that the Shocks provide resistance.
2. Shocks on steppers get **HOT** during use. To avoid burns, do not touch the shocks until they have time to cool.
3. Verify that the Warning Label is in place and easy to read. Call Stamina Products immediately (1-800-375-7520) for a replacement Warning Label if the Warning Label is missing or damaged.
3. It is the sole responsibility of the user/owner to ensure that regular maintenance is performed.
4. Verify that all nuts and bolts are present and properly tightened. Replace missing nuts and bolts. Tighten loose nuts and bolts.
5. Worn or damaged components shall be replaced immediately or the **Space Mate Folding Stepper** removed from service until repair is made.
6. Only Stamina Products supplied components shall be used to maintain/repair the **Space Mate Folding Stepper**.
7. Keep your **Space Mate Folding Stepper** clean by wiping with an absorbent cloth after use.

STORAGE

The **Space Mate Folding Stepper** is designed to fold for easy storage. You can store your **Space Mate Folding Stepper** as illustrated after your workout. Please follow the following process:

STEP 1

Slide the **SHOCK ADJUSTMENTS** to the back end of the slots on the **PEDAL ARMS(5, 6)**. Loosen the **LOCKING KNOB(18)** on the **HANDLEBAR(4)**. Remove the **LOCKING PIN(19)** on the **HANDLEBAR(4)**. Refer to illustration 1.

STEP 2

Swing the **HANDLEBAR(4)** down to the front side to fold the **STEPPER**. Refer to illustration 2.

STEP 3

Illustration 3 shows the **Space Mate Folding Stepper** after folding. Store the **LOCKING PIN(19)** into the hole in the **UPRIGHT(2)**.

WARNING: When folding and unfolding the **Space Mate Folding Stepper**, keep all children away from the **Space Mate Folding Stepper** and make sure your hands are clear of any folding or pinch point.

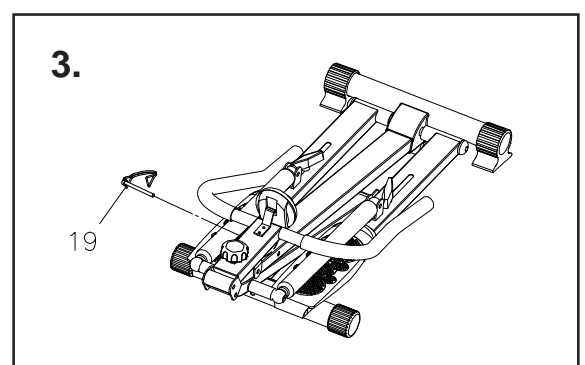
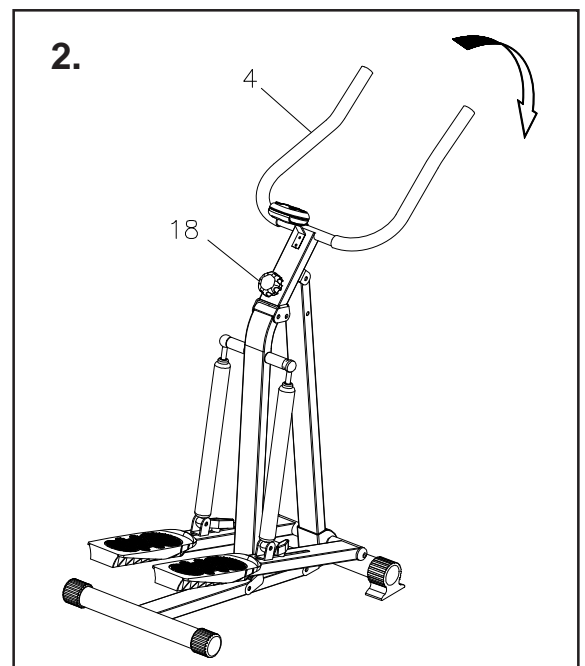
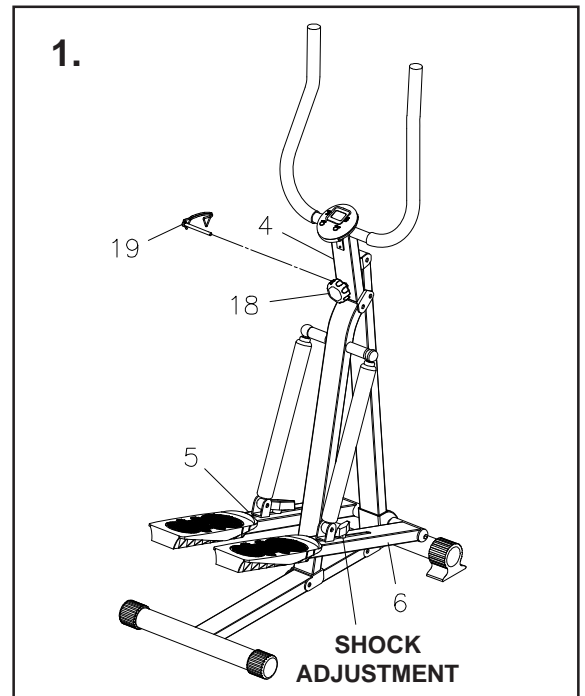

CONDITIONING GUIDELINES

How you begin your exercise program depends on your physical condition. If you have been inactive for several years, or are severely overweight, you must start slowly and increase your time on the **Space Mate Folding Stepper** gradually: a few minutes per workout.

Initially, you may be able to exercise only for a few minutes in your target zone, however, your aerobic fitness will improve over the next six to eight weeks. Don't be discouraged if it takes longer. It's important to work at your own pace. Ultimately, you'll be able to exercise continuously for 30 minutes. The better your aerobic fitness, the harder you will have to work to stay in your target zone. Please remember these essentials:

- Have your doctor review your training and diet programs to advise you of a workout routine you should adopt.
- Begin your training program slowly with realistic goals that have been set by you and your doctor.
- Monitor your pulse frequently. Establish your target heart rate base on your age and condition.
- Set up your **Space Mate Folding Stepper** on a flat, even surface at least 3 feet from walls and furniture.

EXERCISE INTENSITY

To maximize the benefits of exercising, it is important to exercise with the proper intensity. The proper intensity level can be found by using your heart rate as a guide. For effective aerobic exercise, your heart rate should be maintained at a level between 70% and 85% of your maximum heart rate as you exercise. This is known as your target zone. You can find your target zone in the table below. Target zones are listed for both unconditioned and conditioned persons according to age.

AGE	UNCONDITIONED TARGET ZONE (BEATS/MIN.)	CONDITIONED TARGET ZONE (BEATS/MIN.)
20	138~167	133~162
25	136~166	132~160
30	135~164	130~158
35	134~162	129~156
40	132~161	127~155
45	131~159	125~153
50	129~156	124~150
55	127~155	122~149
60	126~153	121~147
65	125~151	119~145
70	123~150	118~144
75	122~147	117~142
80	120~146	115~140
85	118~144	114~139

During the first few months of your exercise program, keep your heart rate near the low end of your target zone as you exercise. After a few months, your heart rate can be increased gradually until it is near the middle of your target zone as you exercise.

To measure your heart rate manually, stop exercising but continue moving your legs or walking around and place two fingers on your wrist. Take a six-second heartbeat count and multiply the results by 10 to find your heart rate. For example, if your six-second heartbeat count is 14, your heart rate is 140 beats per minute. (A six-second count is used because your heart rate will drop rapidly when you stop exercising.) Adjust the intensity of your exercise until your heart rate is at the proper level.

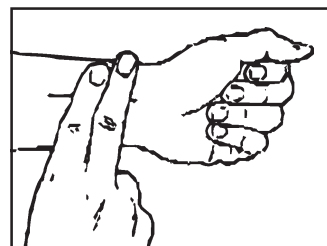

WARM-UP and COOL-DOWN

Warm-up The purpose of warming up is to prepare your body for exercise and to minimize injuries. Warm up for two to five minutes before strength-training or aerobic exercising. Perform activities that raise your heart rate and warm the working muscles. Activities may include brisk walking, jogging, jumping jacks, jump rope, and running in place

Stretching Stretching while your muscles are warm after a proper warm-up and again after your strength or aerobic training session is very important. Muscles stretch more easily at these times because of their elevated temperature, which greatly reduces the risk of injury. Stretches should be held for 15 to 30 seconds. Do not bounce.

Suggested Stretching Exercises

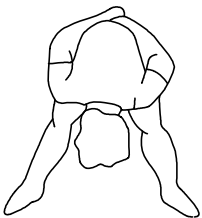

Lower Body Stretch

Place feet shoulder-width apart and lean forward. Keep this position for 30 seconds using the body as a natural weight to stretch the backs of the legs. **DO NOT BOUNCE!** When the pull on the back of the legs lessen, try a lower position gradually.



Floor Stretch

While sitting on the floor, open the legs as wide as possible. Stretch the upper body toward the knee on the right leg by using your arms to pull your chest to your thighs. Hold this stretch 10 to 30 seconds. **DO NOT BOUNCE!** Do this stretch 10 times. Repeat the stretch with the left leg.

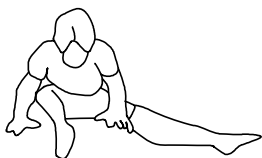

Bent Torso Pulls

While sitting on the floor, have legs apart one leg straight and one knee bent. Pull the chest down to touch the thigh on the leg that is bent and twist at the waist. Hold this position at least 10 seconds. Repeat 10 times on each side.

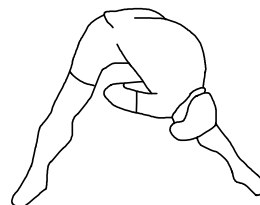
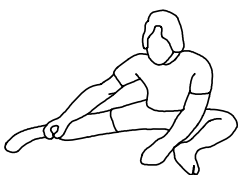

Bent Over Leg Stretch

Stand with feet shoulder-width apart and lean forward as illustrated. Using the arms, **gently** pull the upper body towards the right leg. Let the head hang down. **DO NOT BOUNCE!** Hold the position a minimum of 10 seconds. Repeat pulling the upper body to the left leg. Do this stretch several times slowly.

Remember always to check with your physician before starting any exercise program.

Cool-Down The purpose of cooling down is to return the body to its normal, or near normal, resting state at the end of each exercise session. A proper cool-down slowly lowers your heart rate and allows blood to return to the heart. Your cool-down should include the stretches listed above and should be completed after each strength-training session.

WARRANTY

Stamina Products, Inc. warrants that this product will be free from defects in materials and workmanship under normal use, service and proper operation for a period of 90 days on the parts and one year on the frame from the date of the original purchase from an authorized retailer. **THIS WARRANTY SHALL NOT APPLY TO ANY PRODUCT WHICH HAS BEEN SUBJECT TO COMMERCIAL USE, ABUSE, MISUSE, ALTERATION OF ANY TYPE OR CAUSE OR TO ANY DEFECT OR DAMAGE CAUSED BY REPAIR, REPLACEMENT, SUBSTITUTION OR USE WITH PARTS OTHER THAN PARTS PROVIDED BY STAMINA PRODUCTS, INC.** Commercial use includes use of the product in athletic clubs, health clubs, spas, gymnasiums, exercise facilities, and other public or semipublic facilities whether or not the product's use is in furtherance of a profit making enterprise, and all other use which is not for personal, family, or household purposes.

To implement this limited warranty, send a written notice stating your name, date, and place of purchase and a brief description of the defect along with your receipt to **Stamina Products, Inc. P.O. Box 1071, Springfield Missouri, USA, 65801-1071** or call us at **1 (800) 375-7520**. If the defect is covered under this limited warranty, you will be requested to return the product or part to us for free repair or replacement at our option. **NO ACTION FOR BREACH OF THIS LIMITED WARRANTY MAY BE COMMENCED MORE THAN ONE (1) YEAR AFTER THE DATE THE ALLEGED BREACH WAS OR SHOULD HAVE BEEN DISCOVERED. NO ACTION FOR BREACH OF ANY IMPLIED WARRANTY MAY BE COMMENCED MORE THAN ONE (1) YEAR AFTER DELIVERY OF THE PRODUCT TO THE PURCHASER.** This limited warranty is not transferable. **IF ANY PART OF THE PRODUCT IS NOT IN COMPLIANCE WITH THIS LIMITED WARRANTY OR ANY IMPLIED WARRANTY, THE REMEDY OF REPAIR OR REPLACEMENT IS THE EXCLUSIVE REMEDY AVAILABLE TO YOU.** In the event that the purchaser makes any claim under this limited warranty or any implied warranty, the Warrantor reserves the right to require the product to be returned for inspection, at the purchaser's expense, to the Warrantor's premises in Springfield, Missouri. Return of the enclosed warranty registration card is not required for warranty coverage, but is merely a way of establishing the date and place of purchase.

Stamina Products, Inc. **SHALL NOT BE LIABLE FOR THE LOSS OF USE OF ANY PRODUCT, LOSS OF TIME, INCONVENIENCE, COMMERCIAL LOSS OR ANY OTHER INDIRECT, CONSEQUENTIAL, SPECIAL OR INCIDENTAL DAMAGES DUE TO BREACH OF THE ABOVE WARRANTY OR ANY IMPLIED WARRANTY.**

This limited warranty is the only written or express warranty given by Stamina Products, Inc. This warranty gives you specific legal rights, and you may also have other legal rights which vary from state to state. **ANY OTHER RIGHT WHICH YOU MAY HAVE, INCLUDING ANY IMPLIED WARRANTY OR MERCHANTABILITY OR FITNESS FOR A PARTICULAR PURPOSE, IS LIMITED IN DURATION TO THE DURATION OF THIS WARRANTY.**

The laws in some jurisdictions restrict the rights of manufacturers and distributors of consumer goods to disclaim or limit implied warranties and consequential and incidental damages with respect thereto. If any such law is found to be applicable, the foregoing disclaimers and limitations of and on implied warranties and consequential and incidental damages with respect thereto shall be disregarded and shall be deemed not to have been made to the extent necessary to comply with such legal restriction.

PRODUCT PARTS DRAWING

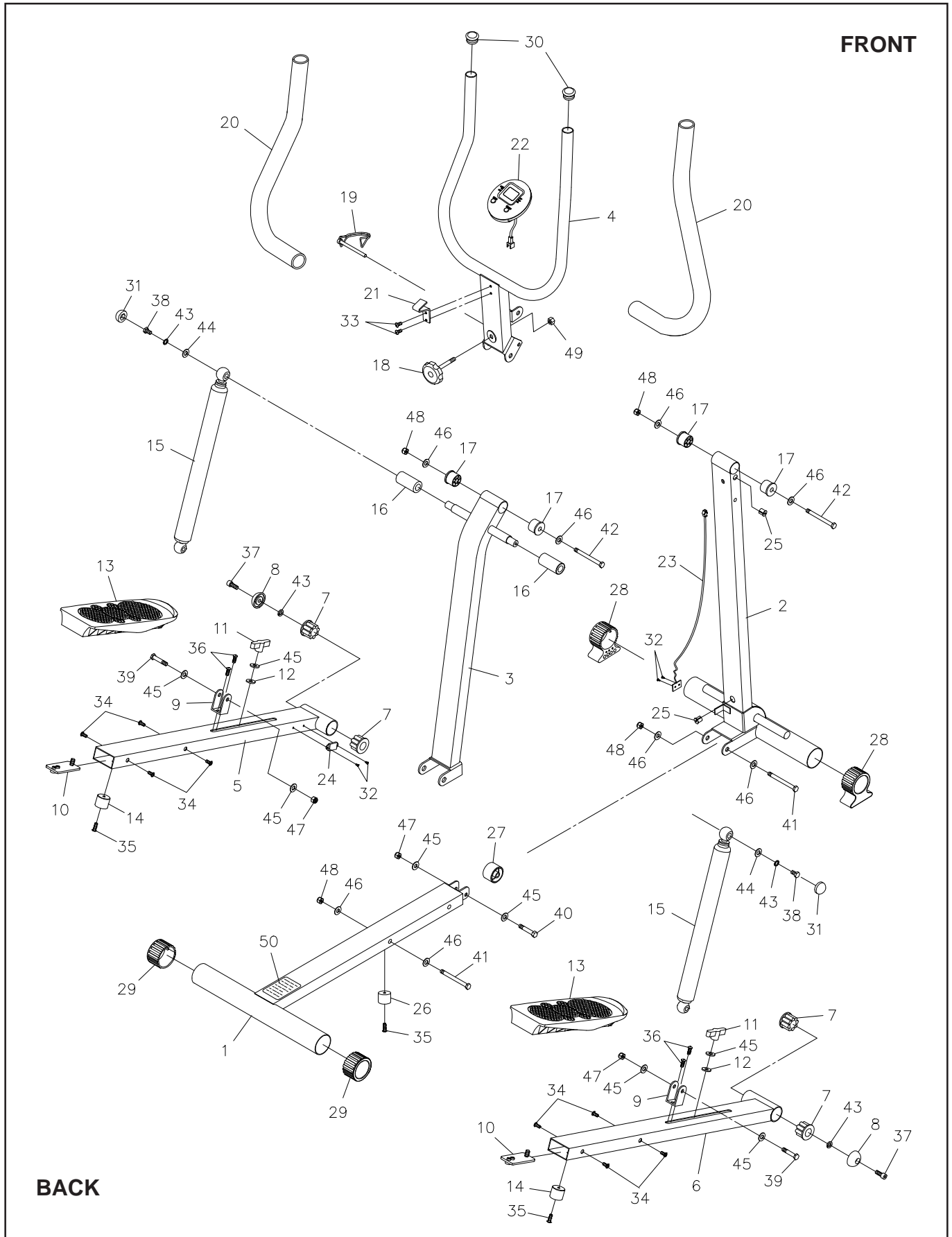

PARTS LIST

DIAGRAM#	PART NAME	QTY
1	Base Frame	1
2	Upright	1
3	Support Frame	1
4	Handlebar	1
5	Left Pedal Arm	1
6	Right Pedal Arm	1
7	Pedal Bushing	4
8	Securing Cap	2
9	Adjustment Bracket	2
10	Adjustment Slide	2
11	T Knob	2
12	Plastic Washer (M8)	2
13	Pedal Cap	2
14	Pedal Bumper	2
15	Shock	2
16	Sleeve	2
17	Upright Bushing	4
18	Locking Knob	1
19	Locking Pin	1
20	Foam Grip	2
21	Mounting Bracket	1
22	Meter	1
23	Sensor Wire	1
24	Magnet	1
25	Grommet Plug	2
26	Base Stand	1
27	Wheel	1
28	Stand Cap	2
29	Endcap	2
30	Round Plug (25mm)	2
31	Nut Cap	2
32	Screw, Round Head (M3 x 15mm)	4
33	Screw, Round Head (M5 x 0.8 x 15mm)	2
34	Bolt, Round Head (M6 x 1 x 16mm)	8
35	Bolt, Round Head (M6 x 1 x 20mm)	3
36	Bolt, Round Head /w nylock (M6 x 1 x 20mm)	4
37	Bolt, Socket Head (M8 x 1.25 x 16mm)	2
38	Bolt, Hex Head (M8 x 1.25 x 20mm)	2
39	Bolt, Hex Head (M8 x 1.25 x 42mm)	2
40	Bolt, Hex Head (M8 x 1.25 x 46mm)	1
41	Bolt, Hex Head (M10 x 1.5 x 82mm)	2
42	Bolt, Hex Head (M10 x 1.5 x 86mm)	2
43	Spring Washer (M8)	4
44	Washer (M8 x ø23mm x 2mm thick)	2
45	Washer (M8 x ø19mm x 1.5mm thick)	8
46	Washer (M10)	8
47	Nylock Nut (M8 x 1.25)	3
48	Nylock Nut (M10 x 1.5)	4
49	Nut (M10 x 1.5)	1
50	Warning Label	1
51	Manual	1

NOTES

NOTES

FAX/MAIL ORDERING FORM

Please do not return the product. For your convenience, Stamina has a Customer Service Department with a toll-free number. Should a part be missing or a defective part found, please call **1 (800) 375-7520** (in the U.S.) between 8:00 A.M. and 5:00 P.M. Central Time, Monday through Friday or fill out the fax sheet ordering form below and fax it to **(417) 889-8064**. Our Customer Service Department will be able to assist you with your problem and the part will be mailed directly to your house.



TELEPHONE
CUSTOMER SERVICE
Tel: 1 (800) 375-7520



FAX
CUSTOMER SERVICE
Fax: (417) 889-8064



ONLINE
CUSTOMER SERVICE
parts@staminaproducts.com
www.staminaproducts.com



MAIL
STAMINA PRODUCTS, INC.
ATTN: Customer Service
P.O. Box 1071
Springfield, MO. 65801-1071



Detach and Mail or Fax the Form Below



Stamina Products, Inc.
P.O. Box 1071
Springfield, MO 65801-1071

Mr./Ms: _____
Address: _____ Apt. #: _____
City: _____ State: _____ Zip Code: _____

IMPORTANT : We must have your phone number in order to process the order!

Phone #: () _____ Work Phone #: () _____
Date Purchased: _____
Model #: _____
Purchased From: _____

IMPORTANT : Before filling out the form below make sure you have the right information.
Refer to the parts list to make sure you're ordering the right parts!

PART #	DESCRIPTION	QUANTITY
EXAMPLE: 1	Rear Unit Assembly	1

Free Manuals Download Website

<http://myh66.com>

<http://usermanuals.us>

<http://www.somanuals.com>

<http://www.4manuals.cc>

<http://www.manual-lib.com>

<http://www.404manual.com>

<http://www.luxmanual.com>

<http://aubethermostatmanual.com>

Golf course search by state

<http://golfingnear.com>

Email search by domain

<http://emailbydomain.com>

Auto manuals search

<http://auto.somanuals.com>

TV manuals search

<http://tv.somanuals.com>