

SANDBLASTER® SBN

Low NO_x Commercial Gas Water Heater

- 80% Thermal Efficiency
- Front, Top or Rear Water Connections
- Hydro Cannon Self-Cleaning Device
- Complies with SCAQMD Rule 1146.2
Southern California and Texas Approved



State Water Heaters' Sandblaster is the original Self-Cleaning commercial gas water heater, with a proven design that automatically reduces sediment buildup, the number one threat to any water heater's life expectancy and energy-efficiency.

The new computer designed Hydro Cannon self-cleaning device injects cold water into the tank under pressure and then uses a venturi action to create self-cleaning turbulence. Self-Cleaning action keeps sediment in suspension, and keeps it moving, so it does not get a chance to settle down. Sediment that would otherwise build up in the tank is harmlessly carried out when hot water is drawn. With reduced sediment buildup, Sandblaster commercial water heaters retain their rated efficiency longer, last longer, and help keep water heating costs down!

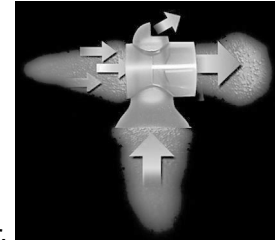

- **3-Year or Optional 5-Year Tank Warranty.**
- **Low NO_x** – Complies with SCAQMD Rule 1146.2. Southern California and Texas Approved.
- **ASME Construction** available on 200,000 thru 500,000 Btu sizes.
- **Induced Draft Built-In Blower** – Blower is built into the top cover, factory mounted and wired. No draft hood or barometric damper required.
- **Hydro Cannon Self-Cleaning Feature** – New computer designed device automatically reduces harmful sediment buildup inside the tank. Sandblaster® SBN™ stays energy-efficient, so it saves money throughout its life.
- **Foam insulation** – Reduces heat loss over 2-1/2 times more effectively than standard fiberglass.
- **CSA Certified and ASME Rate T&P Relief valve**
- **Factory-installed Energy Cut-Off ("ECO") safety switch.**
- **Tank Inspection Port** for easy access to tank interior on all models.
- **Maximum Hydrostatic Working Pressure: 160 psi.**
- **Three Water Connection Options** – Inlet and outlet connections are located on the top, front and rear offering installation flexibility (Hydro Cannon device on front connection only).

- **Anodes** – Long lasting stainless steel core anodes.
- **On/Off Power Switch** – Eliminates the need to wire a separate electrical connection box.
- **Intermittent Ignition Device** – Eliminates standing pilot and provides flame failure response in less than one second.
- **Glass Lined Tank** – Glass is applied after the complete tank has been assembled to give a seamless barrier against corrosion by hot water.
- **Fully Tested for Safety and Performance** – Design certified by the Underwriter's Laboratory for 180°F hot water service. Meets rigid requirements of the National Sanitation Foundation when equipped with optional leg kit. Certified for use on combustible flooring. Meets or exceeds the thermal efficiency and/or standby loss requirements of the U.S. Department of energy and current addition of ASHRAE/IESNA 90.1.
- **Options:**
 - **Leg Kit for UL Sanitation to Meet NSF 5** – Kit #9003425205.
 - **Manifold Kits for Multiple Gas Heater Installations:**
 - Dual Manifold Kit #9003426205
 - Triple Manifold Kit #3003427205
 - Quad Manifold Kit #3003428205

For more information on Sandblaster® contact:
State Water Heaters
500 Tennessee Waltz Parkway, Ashland City, TN 37015
800-365-0024 Toll-free USA
www.statewaterheaters.com

SCGSS000407 August 2008R

SOLID.STATE.



SANDBLASTER® SBN

Low NO_x Commercial Gas Water Heater

Model Number	Gallon Cap.	Input Rate BTUH	First Hour Delivery Gallons 100° Rise	Recovery			Dimensions in Inches										Approx. Shipping Weight (lbs.)	Approx. ASME Weight (lbs.)
				80°	100°	140°	A	B	C	D	E	F	G	H	I	J		
SBN71 120NE	71	120,000	166	145	116	83	63	4 ¹ / ₄	59 ¹ / ₂	50 ⁷ / ₈	19 ⁵ / ₈	19	1 ¹ / ₂	51 ⁷ / ₈	5	27 ³ / ₄	400	—
SBN81 154NE	81	154,000	206	187	149	107	70	4 ¹ / ₄	66 ¹ / ₂	57 ⁷ / ₈	19 ⁵ / ₈	19	1 ¹ / ₂	59	6	27 ³ / ₄	470	—
SBN100 180NE	100	180,000	245	218	175	125	70	4 ¹ / ₄	66 ¹ / ₂	57 ⁷ / ₈	19 ⁵ / ₈	19	1 ¹ / ₂	59	6	27 ³ / ₄	470	—
SBN100 199NE	100	199,000	263	241	193	138	67	4 ¹ / ₄	66 ¹ / ₂	57 ⁷ / ₈	19 ⁵ / ₈	19	1 ¹ / ₂	59	6	27 ³ / ₄	470	—
SBN100 200NES	100	200,000	263	241	193	138	72	4 ¹ / ₂	70	61 ⁵ / ₈	20 ¹ / ₂	21	1 ¹ / ₂	61 ¹ / ₂	6	27 ³ / ₄	603	—
SBN100 200NES A	100	200,000	263	241	193	138	72	4 ¹ / ₂	70	61 ⁵ / ₈	20 ¹ / ₂	21	1 ¹ / ₂	61 ¹ / ₂	6	27 ³ / ₄	—	625
SBN100 250NE	100	250,000	312	303	242	173	72	4 ¹ / ₂	70	61 ⁵ / ₈	20 ¹ / ₂	21	1 ¹ / ₂	61 ¹ / ₂	6	27 ³ / ₄	603	—
SBN100 250NE A	100	250,000	312	303	242	173	72	4 ¹ / ₂	70	61 ⁵ / ₈	20 ¹ / ₂	21	1 ¹ / ₂	61 ¹ / ₂	6	27 ³ / ₄	—	625
SBN100 275NE	100	275,000	337	333	267	190	72	4 ¹ / ₂	70	61 ⁵ / ₈	20 ¹ / ₂	21	1 ¹ / ₂	61 ¹ / ₂	6	27 ³ / ₄	603	—
SBN100 275NE A	100	275,000	337	333	267	190	72	4 ¹ / ₂	70	61 ⁵ / ₈	20 ¹ / ₂	21	1 ¹ / ₂	61 ¹ / ₂	6	27 ³ / ₄	—	625
SBN85 310NE	85	310,000	360	376	300	215	73	4 ¹ / ₂	72	61 ⁵ / ₈	20 ¹ / ₂	21	1 ¹ / ₂	61 ¹ / ₂	6	27 ³ / ₄	603	—
SBN85 310NE A	85	310,000	360	376	300	215	73	4 ¹ / ₂	72	61 ⁵ / ₈	20 ¹ / ₂	21	1 ¹ / ₂	61 ¹ / ₂	6	27 ³ / ₄	—	625
SBN85 366NE	85	366,000	415	444	355	254	73	4 ¹ / ₂	72	62 ¹ / ₂	22 ¹ / ₂	21	3 ³ / ₄	63	6	27 ³ / ₄	725	—
SBN85 366NE A	85	366,000	415	444	355	254	73	4 ¹ / ₂	72	62 ¹ / ₂	22 ¹ / ₂	21	3 ³ / ₄	63	6	27 ³ / ₄	—	833
SBN85 390NE	85	390,000	438	473	378	270	73	4 ¹ / ₂	72	62 ¹ / ₂	22 ¹ / ₂	21	3 ³ / ₄	63	6	27 ³ / ₄	725	—
SBN85 390NE A	85	390,000	438	473	378	270	73	4 ¹ / ₂	72	62 ¹ / ₂	22 ¹ / ₂	21	3 ³ / ₄	63	6	27 ³ / ₄	—	833

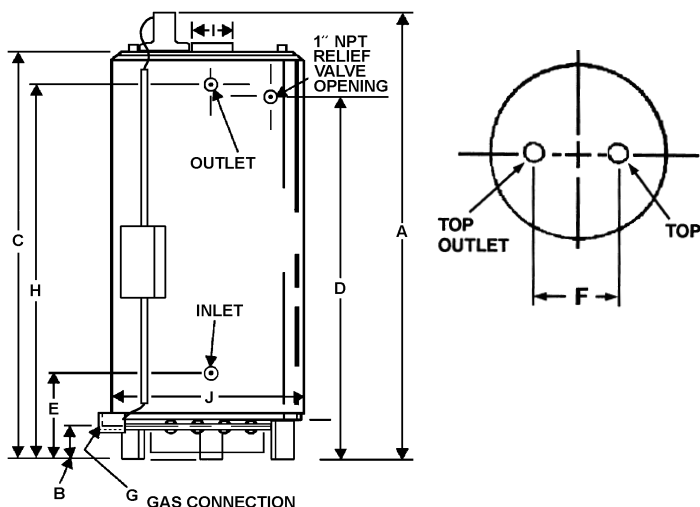

Model Number	Water Connections in Inches					
	Inlet			Outlet		
	Top	Front	Rear	Top	Front	Rear
SBN71 120NE	1 ¹ / ₂	1 ¹ / ₂	1 ¹ / ₂	1 ¹ / ₂	1 ¹ / ₂	1 ¹ / ₂
SBN81 154NE	1 ¹ / ₂	1 ¹ / ₂	1 ¹ / ₂	1 ¹ / ₂	1 ¹ / ₂	1 ¹ / ₂
SBN100 180NE	1 ¹ / ₂	1 ¹ / ₂	1 ¹ / ₂	1 ¹ / ₂	1 ¹ / ₂	1 ¹ / ₂
SBN100 199NE	1 ¹ / ₂	1 ¹ / ₂	1 ¹ / ₂	1 ¹ / ₂	1 ¹ / ₂	1 ¹ / ₂
SBN100 200NES	1 ¹ / ₂	1 ¹ / ₂	2	1 ¹ / ₂	1 ¹ / ₂	2
SBN100 200NES A	1 ¹ / ₂	1 ¹ / ₂	2	1 ¹ / ₂	1 ¹ / ₂	2
SBN100 250NE	1 ¹ / ₂	1 ¹ / ₂	2	1 ¹ / ₂	1 ¹ / ₂	2
SBN100 250NE A	1 ¹ / ₂	1 ¹ / ₂	2	1 ¹ / ₂	1 ¹ / ₂	2
SBN100 275NE	1 ¹ / ₂	1 ¹ / ₂	2	1 ¹ / ₂	1 ¹ / ₂	2
SBN100 275NE A	1 ¹ / ₂	1 ¹ / ₂	2	1 ¹ / ₂	1 ¹ / ₂	2
SBN85 310NE	1 ¹ / ₂	1 ¹ / ₂	2	1 ¹ / ₂	1 ¹ / ₂	2
SBN85 310NE A	1 ¹ / ₂	1 ¹ / ₂	2	1 ¹ / ₂	1 ¹ / ₂	2
SBN85 366NE	1 ¹ / ₂	1 ¹ / ₂	1 ¹ / ₂	1 ¹ / ₂	1 ¹ / ₂	1 ¹ / ₂
SBN85 366NE A	1 ¹ / ₂	1 ¹ / ₂	1 ¹ / ₂	1 ¹ / ₂	1 ¹ / ₂	1 ¹ / ₂
SBN85 390NE	1 ¹ / ₂	1 ¹ / ₂	1 ¹ / ₂	NA	1 ¹ / ₂	1 ¹ / ₂
SBN85 390NE A	NA	1 ¹ / ₂	1 ¹ / ₂	NA	1 ¹ / ₂	1 ¹ / ₂



Sandblaster® SBN™ Sample Specifications

Gas water heater(s) shall be a State Water Heaters' Sandblaster® SBN™ Model Number, _____, with a _____ gallon storage capacity, an input rate of _____ Btu/Hour _____ gas, and a recovery rate of _____ gallons per hour at a _____ degree Fahrenheit temperature rise.

Units shall have hot surface ignition requiring a 120VAC/5AMP power supply, fan-assisted combustion, and easily removable tubular stainless steel burner tube with individual orifices. The ignition control shall have integrated self-diagnostic capability and must prove combustion fan operation for system to operate. The units comply with SCAQMD Rule 1146.2, Southern California and Texas approved. The water heater(s) shall not use flame impingement or flame quenching as a means of controlling NO_x emissions. The water heater tank shall be additionally protected against premature failure in the following ways:

- 1.A _____-year limited warranty against failure due to corrosion, metal fatigue or overheating caused by the buildup of scale, film or other sediment.
 2. Against electrolytic corrosion by multiple, factory-installed anodes.
 3. Against failure due to overheating caused by the buildup of scale, film and other sediment by a self cleaning device. The device shall be properly positioned so that it directs the flow of inlet water in such a way that microscopic particles of precipitated solids shall be kept in suspension and exhausted from the water heater on that or successive hot water draws.
- The burner(s) shall have an individual orifice for each burner tube and be constructed of tubular aluminized or stainless steel mounted in an easily removable tray.
- Water heater(s) shall have the UL seal of certification, a working pressure of 160 psi, CSA Certified and ASME rated T&P relief valve, and a 2 3/4" x 3 3/4" tank inspection port.

For more information on Sandblaster® contact:
 State Water Heaters
 500 Tennessee Waltz Parkway, Ashland City, TN 37015
800-365-0024 Toll-free USA
www.statewaterheaters.com

SCGSS000407 August 2008R

SOLID.STATE.



Free Manuals Download Website

<http://myh66.com>

<http://usermanuals.us>

<http://www.somanuals.com>

<http://www.4manuals.cc>

<http://www.manual-lib.com>

<http://www.404manual.com>

<http://www.luxmanual.com>

<http://aubethermostatmanual.com>

Golf course search by state

<http://golfingnear.com>

Email search by domain

<http://emailbydomain.com>

Auto manuals search

<http://auto.somanuals.com>

TV manuals search

<http://tv.somanuals.com>