

SELECT[®] DIRECT-VENT

Residential Gas Water Heaters



Direct-Vent Design - FVIR compliant, one-pipe, dual channel closed-combustion system draws all make-up air from outside the home, eliminating problems caused by insufficient indoor ventilation. Horizontal air intake and venting on all models up to 80 inches from outside wall, with no electrical power needed.

Diffuser Dip Tube - Reduces lime and sediment buildup, maximizes hot water output. Made of State PEXAN[™], a cross-link PEX polymer that can withstand long-term exposure to water temperatures up to 400°F.

Green Choice[™] Eco-Friendly Gas Burner - Patented design reduces NOx emissions and complies with Southern California and Texas requirements.

Durable Brass Tamper-Resistant Drain Valve.

Glasslined Tank - For long-lasting protection against rust and corrosion.

Push Button Piezo Ignitor - Simplifies lighting pilots with one hand spark ignition.

Anode Rod - For added protection against rust and corrosion.

Factory-Installed Temperature & Pressure (T&P) Relief Valve.

Thick, CFC-Free Foam Insulation.

6-Year Limited Tank and Parts Warranty.

Code Compliance – All models meet or exceed federal minimum energy standards effective January 20, 2004, according to latest editions of the National Appliance Energy Conservation Act (NAECA). They also comply with the latest editions of the B.O.C.A. National Codes, C.E.C., U.B.C., S.B.C.C., C.A.B.O. and the H.U.D. standards. All models design-certified by CSA International according to ANS Z21.10.1 standards governing storage-type water heaters.



For more information on Select[®] contact:
State Water Heaters
500 Tennessee Waltz Parkway, Ashland City, TN 37015
800-365-0024 Toll-free USA
www.statewaterheaters.com

SRGSS02207 May 2008R

SOLID. STATE.



SELECT[®] DIRECT-VENT Residential Gas Water Heaters



MODEL NUMBER	FIRST HOUR RATING	ENERGY FACTOR	GALLON CAP	BTU INPUT	RECOVERY 90 DEGREE RISE	DIMENSIONS						VENT PIPE**	SHIPPING WEIGHT
						A***	B	C	D	E	F		
GS6 40 YBDS	73	0.62	40	38,000	41	68	54-3/4	22-1/4	16	12-1/4	45-1/4	Co-Axial	167
GS6 50 YBDS	87	0.60	50	42,000	45	76	63-3/4	22-1/4	16	12-1/4	54	Co-Axial	185
GS6 50 YRDS	88	0.59	50	50,000	55	76	64-3/4	22-1/4	16-1/4	12-1/2	55-1/2	Co-Axial	187
GS6 75 YRDS	131	0.59	75	55,000	60	76	65-3/4	26-1/4	16-1/4	12-1/2	55-1/2	Co-Axial	310

Recoveries are rounded to nearest gallon

Water Connections - 3/4" on all models

**Dual-channel system has 3" vent pipe inside 6" air intake pipe for the 40 & 50-gallon. The 75-gallon models uses a 4" x 7" Co-Axial pipe.

***A dimension is to center line of flue (recommended vent height)

When ordering Propane, change "Y" to "H" in model number (GS6 40 HBDS)

All models have 2" foam cavity

75-gallon water connections are 12" on center.

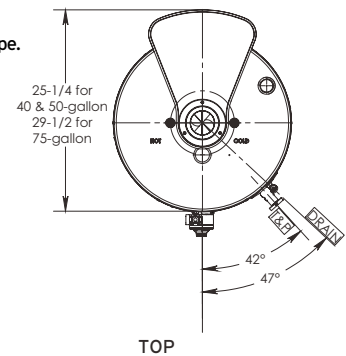

Important! Vent Installation and Termination Requirements

- Maximum horizontal vent distance is 80" to outside of exterior wall.
- Minimum horizontal vent distance is 17" to outside of exterior wall.
- Vent pipes may be trimmed (cut) for short vent installations.
- For vent installation less than 30" the vent restrictor is required. Place restrictor over the flue outlet on heater before installing the outlet vent pipe to the heater.
- Recommended installation height for the heater and vent pipe should be 68" for 40-gallon models and 76" for the 50 and 75-gallon models (vent height).
- Offset Vent Arrangement
 1. When replacing an existing direct vent model, the new vent pipe may drop from the minimum vent height as much as 7 1/4" to exit through the existing vent opening in the exterior wall.
 2. Vent may have one horizontal 90 degree turn before exiting through exterior wall (Do not combine both offset vent arrangements in one installation) (See examples in the installation manual)
- High Rise Vent Arrangement
 3. When vent termination is more than 80" above the base of the heater. The horizontal vent run must be a minimum of 22" from the center of the heater to the outside exterior wall surface. (See example in the installation manual)
- Vent termination clearance hole through the exterior wall should be approximately 7" diameter.
- Snow accumulation and drifting should be considered when locating the termination.
- An optional wire grill vent cap protector is available through the parts department. Request part number 9006627.
- See the installation manual for complete installation and venting requirements.

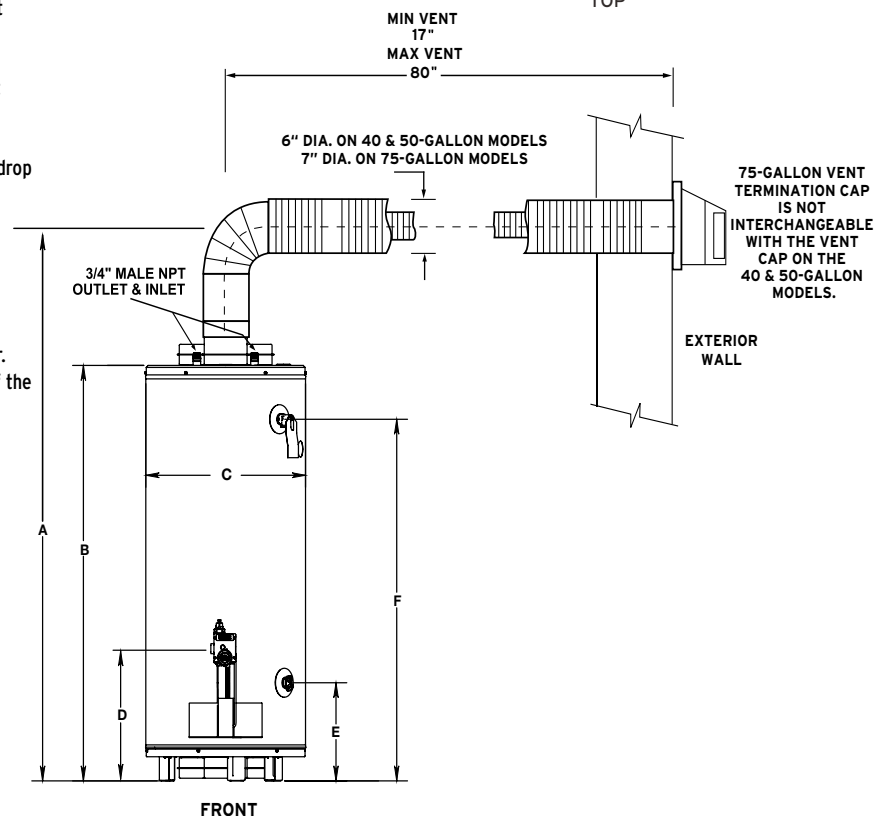

For complete information on limited warranties, consult written warranty, or contact the State Customer Care Center, 1-800-365-0024.

State Industries, Inc. reserves the right to make product changes or improvements without prior notice.

For more information on Select[®] contact:
State Water Heaters
500 Tennessee Waltz Parkway, Ashland City, TN 37015
800-365-0024 Toll-free USA
www.statewaterheaters.com

SRGSS02207

May 2008R

SOLID. STATE.



Free Manuals Download Website

<http://myh66.com>

<http://usermanuals.us>

<http://www.somanuals.com>

<http://www.4manuals.cc>

<http://www.manual-lib.com>

<http://www.404manual.com>

<http://www.luxmanual.com>

<http://aubethermostatmanual.com>

Golf course search by state

<http://golfingnear.com>

Email search by domain

<http://emailbydomain.com>

Auto manuals search

<http://auto.somanuals.com>

TV manuals search

<http://tv.somanuals.com>