



Service Handbook

**For Self-Cleaning
Induced Draft
Multi Flue Commercial
Gas Water Heaters**

SANDBLASTER®

**SBN 71120 through 85390 (A)
SERIES 100 Models**

SBN Meets Low NOx Requirements of SCAQMD
Rules 1121 & 1146.2

Part No. STC-074
\$20.00 Printed in the U.S.A. 0204

 **state**
COMMERCIAL
The Expert's Choice®

**SBN TANK TYPE COMMERCIAL GAS WATER HEATER
SERVICE HANDBOOK**

TABLE OF CONTENTS

SBN Service Handbook Introduction 2-3

Installation Considerations 4

- Clearances 4
- Exterior Clearance 5
- Air Supply 6
- Contaminated Air 9
- Flammable Items 9
- Gas Valve 10
- Outlet View 11
- Venting 12
- Technical Data Venting 13-14

Sequence of Operation 15

- Top View 15
- Front View 16
- White Rogers Control 17
- HSI Board 18
- Wiring Diagram 20
- Electrical Sequence 21

Pre-Service Checklist 22

Control Board Diagnostic LED Interpretation and Troubleshooting

- 120 VAC Check to Heater 23
- Polarity Check 24
- Continuity Check of High Limit 25
- Upper Temperature Probe Check 26
- Inducer Check 27
- Blower Prover/Low Gas Pressure Circuit Check 28
- HSI Voltage and Continuity Check 29
- Igniter and Gas Valve Circuit Check 30
- Gas Valve Coil Continuity Check 31
- Flame Prover Check 32
- Water Temperature Circuit Check 33

SBN TANK TYPE COMMERCIAL GAS WATER HEATER SERVICE HANDBOOK

TABLE OF CONTENTS

Troubleshooting - Conditions	34
LED Troubleshooting	36
Parts List	38
General Questions and Answers	41
Electrical Information	44
Draft Proving (Pressure) Switch Table	44

SBN Service Handbook Introduction

This service handbook is a supplement to the *SBN Installation and Operation Manual*. The handbook provides information on servicing and troubleshooting State Industries SBN water heaters in the field. While this handbook is not intended to be all inclusive, it contains:

- step-by-step procedures with illustrations to verify proper installation, operation, and troubleshooting
- quick reference data to assist in servicing the product line
- answers to common questions encountered in the operation of the product line

The handbook is intended to be used by licensed plumbing professionals. Reference should be made to the installation manual accompanying the product. If you are experiencing a problem not covered in this handbook, please contact the State Industries Technical Information Department at 1-800-527-1953 or your local State Industries representative for further assistance.

No duplication or reproduction of this book may be made without the expressed written authorization of the State Industries.

SBN TANK TYPE COMMERCIAL GAS WATER HEATER SERVICE HANDBOOK

Qualifications

Installation or service of this water heater requires ability equivalent to that of a licensed tradesman in the field involved. Plumbing, air supply, venting, gas supply and electrical testing skills are required.

Tools Required

- Phillips head screwdriver
- standard screwdrivers
- 3/8 and 7/16 inch open end wrench
- set of marked drill bits
- electrical multimeter tester capable of measuring continuity, AC voltage and DC voltage
- gas pressure gauge or manometer (gauge - pt. no. 8099-2)
- water pressure gauge (pt. no. 4798)
- thermometer (pt no. 4870 - range 0 - 220 degrees F)
- 1/2 inch socket with extension for removal of the clean out cover
- 1-1/16 inch socket with extension for anode removal

Custom Commercial Storage Tank Model Number Break Down

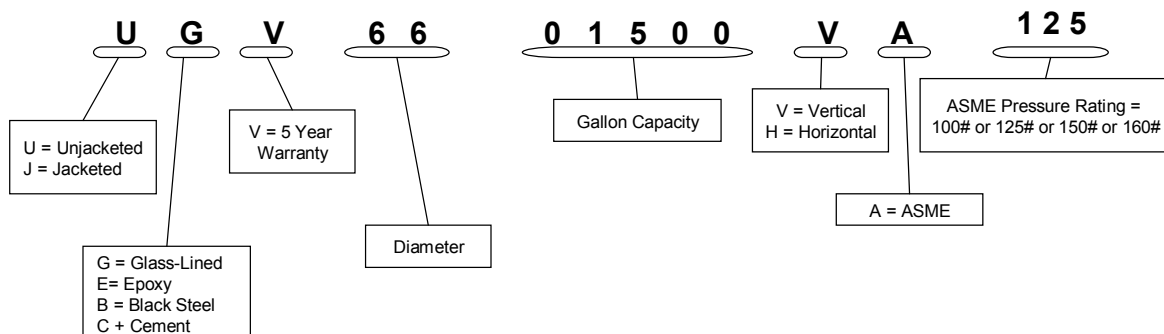

SPECIAL NOTE: All model number appearing on rating plate and carton labels will be compressed. Example: **UGV6601500VA125**

SBN TANK TYPE COMMERCIAL GAS WATER HEATER SERVICE HANDBOOK

INSTALLATION CONSIDERATIONS

This portion of the handbook reviews some often overlooked installation considerations—clearances, air supply, gas pressure requirements, and venting—taking note of necessary installation requirements for SBN. The installation manual covers most of these items in detail.

Clearances

A 24-inch clearance for all serviceable parts is recommended. Clearances may vary between models. See instruction manual or the label on the heater for clearances applicable to your specific model.

Top and Front Views of Minimum Clearances To Combustibles

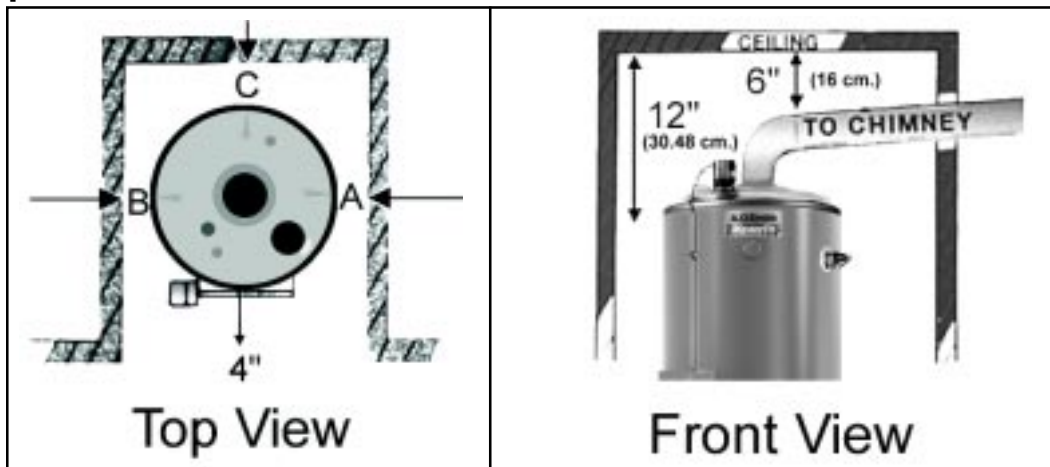

Minimum Clearances To Combustibles				
Model	"A" Right Side	"B" Left Side	"C" Back	"D" Ceiling
SBN 71-120NE, SBN- 81-154NE, SBN 81-180NE, SBN 100-199NE	2"	2"	2"	12"
SBN 100-250NE(A), SBN 100-275NE(A), SBN 85-310NE(A)	3"	3"	3"	12"
SBN 85-366NE(A)	6"	6"	6"	6"
SBN 85-390NE(A)	4"	4"	4"	4"

A, B, and C clearances to non-combustibles is "0" inches - a 12 inch clearance to cover remains unchanged.

SBN TANK TYPE COMMERCIAL GAS WATER HEATER SERVICE HANDBOOK

Exterior Clearance

The illustration below shows the required clearances for venting units using natural draft venting.

Required Exterior Clearances

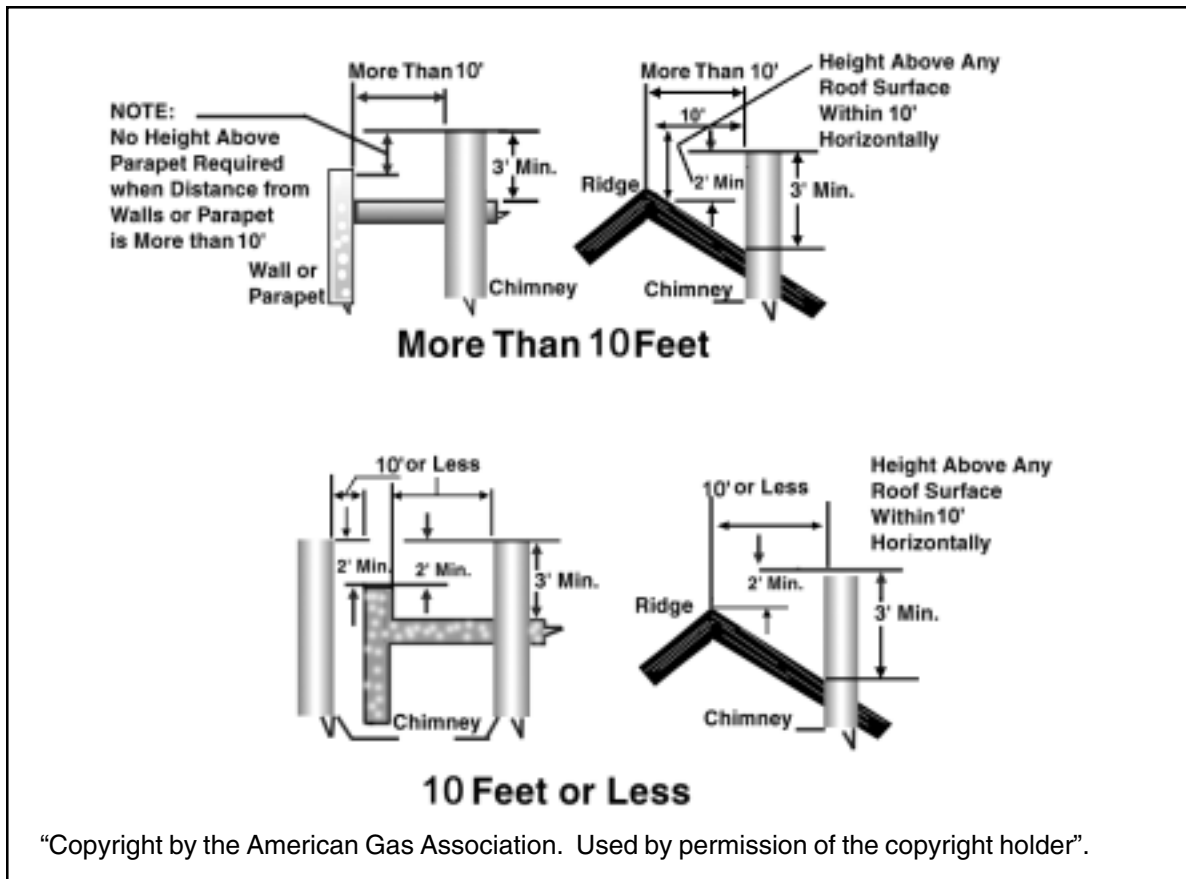

The vent must extend at least 3 feet above the highest point where it passes through a roof of a building and at least 2 feet higher than any portion of a building within a horizontal distance of 10 feet (for vents of 12 inches in diameter or less).

References: NFPA 54 ANSI Z 223.1 SEC 7.5.2a and Sec 7.6.2a may allow reduction to 8 feet with a "listed vent cap."

SBN TANK TYPE COMMERCIAL GAS WATER HEATER SERVICE HANDBOOK

Air Supply

Stoichiometric or theoretical complete combustion requires 10 cubic feet of air per 1,000 BTUH of gas supplied. The National Fuel Gas code also recommends an additional 2.5 cubic feet of "excess" air.

For information on minimum make-up air opening sizes for various building installations, refer to the National Fuel Gas Code NFPA 54, ANSI Z223.1, Sec. 5.3.

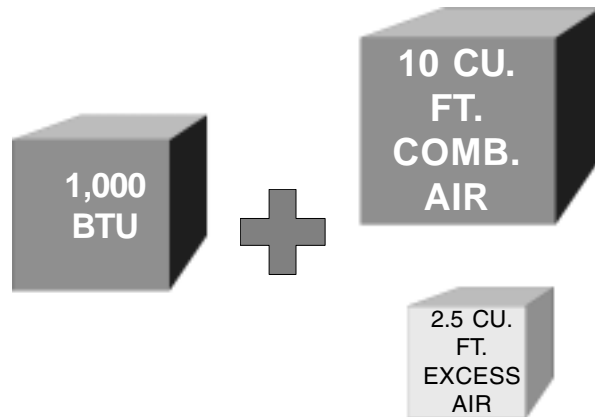

Insufficient make-up air is a major cause of combustion problems.

Insufficient Make-Up Air - Backdraft



One common example is in a restaurant installation where exhaust vent equipment was not considered in sizing make-up requirements. This condition may result in air being backdrafted by the restaurant exhaust equipment through the heater causing the draft proving switch to open and/or erratic heater shutdown.

SBN TANK TYPE COMMERCIAL GAS WATER HEATER SERVICE HANDBOOK

A fresh supply of make-up air for combustion can be supplied to the heater through make-up air ducts, which directly communicate with the outdoors.

Make-Up Air – Direct Communication (Not Direct Vent)

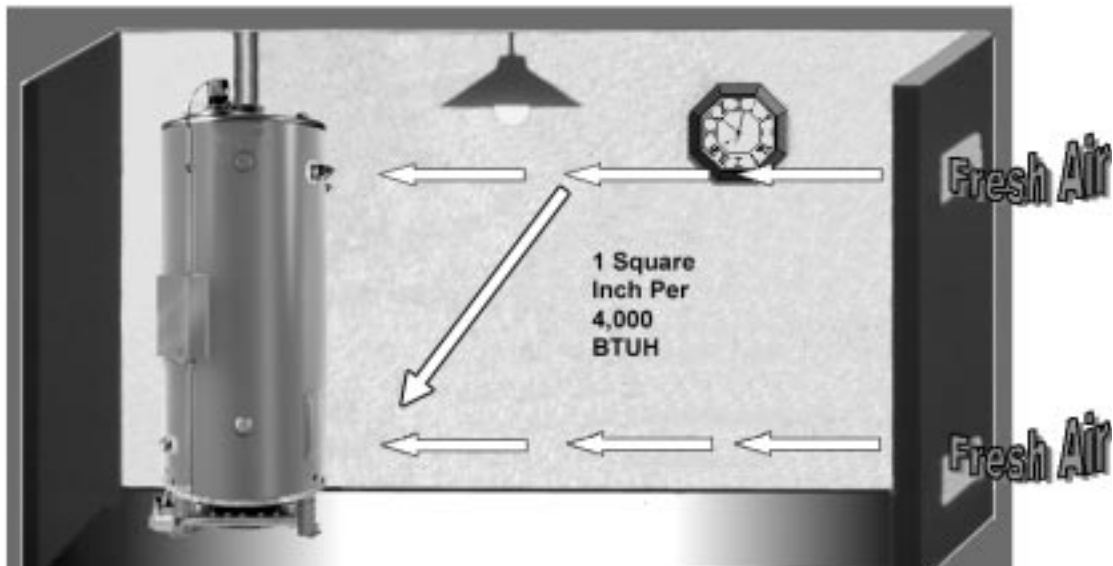

Two openings are required: one within 12 inches of the top of the enclosure and one within 12 inches of the bottom of the enclosure. Each opening must have a free area of not less than 1 square inch per 4,000 BTUH of the total input of all appliances within the enclosure.

The lower opening primarily provides combustion air. The upper opening provides vent dilution air and acts as a relief opening for flue gases should the vent become obstructed or a downdraft condition occur. Additionally, when the heater is installed in a confined space and communicating with the outdoor air, one permanent opening, beginning within 12 inches (30 cm) of the top of the enclosure, must be permitted where the equipment has clearances of at least 1 inch (2.5 cm) from the sides and back, and 6 inches (16 cm) from the front of the appliance. The opening must directly communicate with the outdoors and must communicate through a vertical or horizontal duct to the outdoors or spaces (crawl or attic) that freely communicate with the outdoors, and must have a minimum free area of a) 1 square inch per 3,000 BTUH (7cm² per kW) of the total input of all equipment located in the enclosure and b) not less than the sum of the areas of all vent connectors in the confined space.

SBN TANK TYPE COMMERCIAL GAS WATER HEATER SERVICE HANDBOOK

Often, it is more practical to install vertical make-up ducts to the outdoors.

Make-Up Air - Vertical Ducts

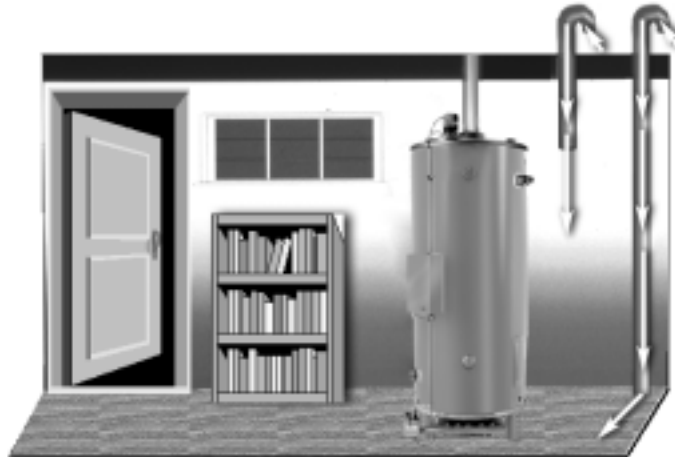

Again, two openings are required: one within 12 inches of the top of the enclosure and one within twelve inches of the bottom of the enclosure. Each opening must have a free area of not less than 1 square inch per 4,000 BTUH of the total input of all appliances within the enclosure.

Make-Up Air - Horizontal Ducts

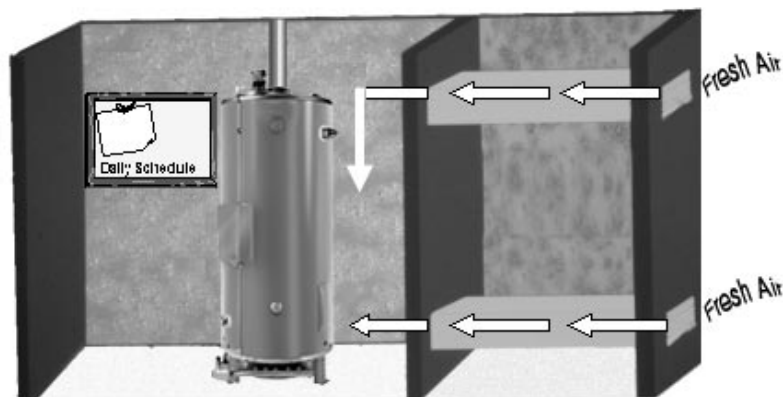

When the heater is installed in an interior room with no roof access for vertical ducts, horizontal make-up air ducts should be installed. When using horizontal ducts, two openings are required - one within 12 inches of the top of the enclosure and one within 12 inches of the bottom of the enclosure. Each opening must have a free area of not less than 1 square inch per 2,000 BTUH of the total input of all appliances within the enclosure.

SBN TANK TYPE COMMERCIAL GAS WATER HEATER SERVICE HANDBOOK

Along with adequate make-up air, the quality of the air is important.

Contaminated Air



Contaminants in combustion air can lead to premature heater failure. Vapors from bleaches, soaps, waxes, salts, etc. are drawn into the combustion chamber with the make-up air and, once fired, mix with water vapor in the gases to form extremely corrosive hydrochloric or hydrofluoric acid and other corrosive by-products.

Air for Combustion – Flammable Items



Flammable items, pressurized containers or any other potentially hazardous articles must never be placed on or adjacent to the heater. Open containers of flammable material should not be stored or used in the same room with the heater.

SBN TANK TYPE COMMERCIAL GAS WATER HEATER SERVICE HANDBOOK

Gas Valve

The supply gas pressure is normally measured at the gas valve inlet gas pressure tap, if available, when the gas is flowing. The manifold gas pressure is measured at the manifold pressure tap of the gas valve when the gas is flowing.

Gas valves used are 24 volt AC combination-step opening gas valves. They incorporate the main valve and gas pressure regulator into one body. The Low Gas Pressure Switch, the Supply Gas Inlet, and the Supply Gas Pressure Tap are shown in the Inlet View to the right.

The top view of the gas valve, shown on the right, shows the Main Gas Regulator, Manifold Pressure Tap, Top Knob, and the Limited Bleed Vent Port. The main gas regulator is found under the silver cap screw. It is factory preset to 3.5 inches W.C. and adjusts gas pressure output from 3.0 to 5 inches water column. *Caution:* Always test the manifold pressure at the outlet when the gas is flowing.

Inlet View

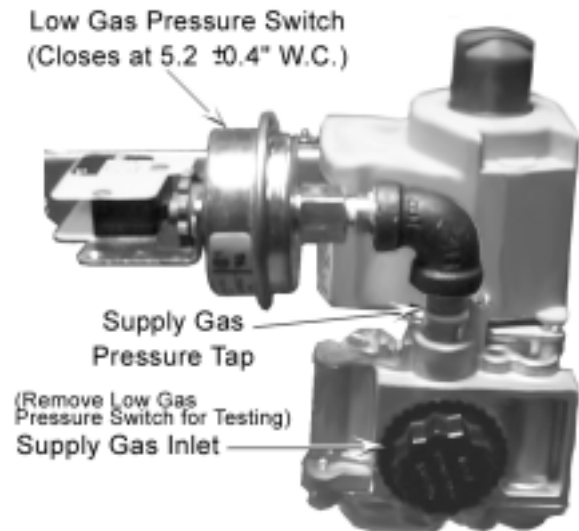

Top View

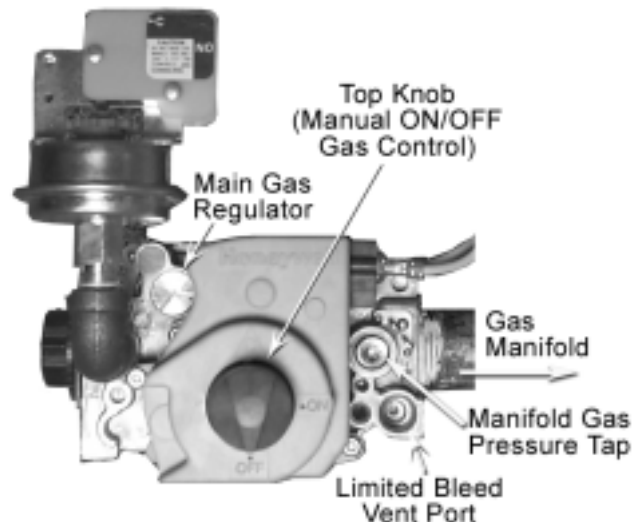

SBN TANK TYPE COMMERCIAL GAS WATER HEATER SERVICE HANDBOOK

Outlet View

The outlet view of the Gas Valve, shown on the right, shows the Manifold Gas Outlet Connection, the two 24 volt Main Valve (MV) Solenoid connections, and the Manifold Pressure Tap. The two yellow wires from the 12-pin plug on the Ignition Board attach to the MV terminals.

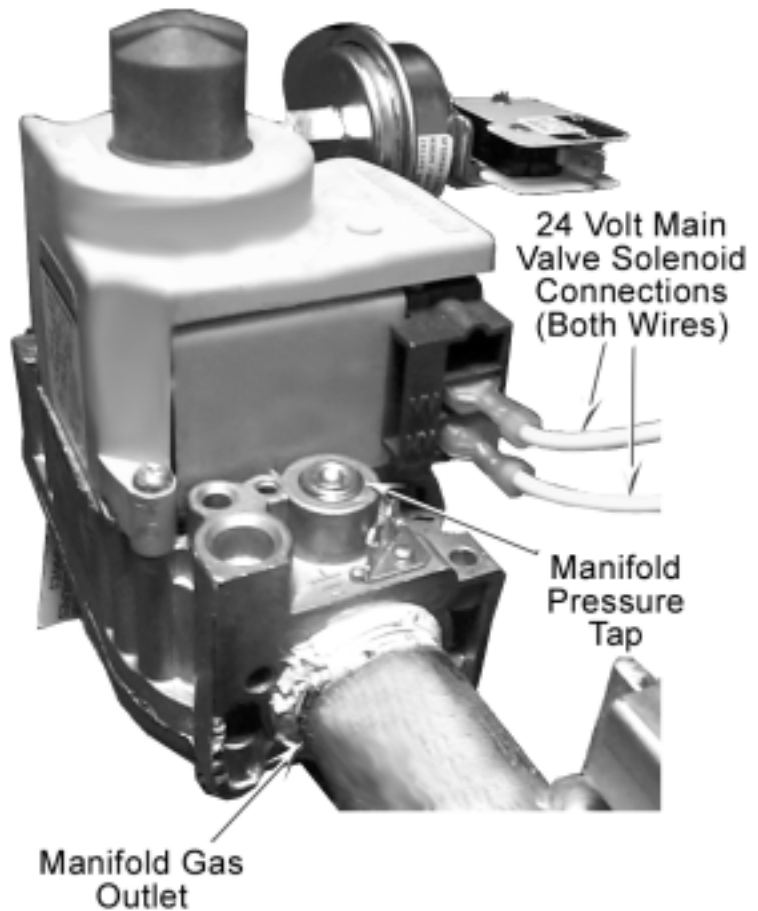

SBN TANK TYPE COMMERCIAL GAS WATER HEATER SERVICE HANDBOOK

Venting

All SBN water heaters are classified by ANSI as Category I (non-condensing, negative pressure venting) appliances. They are approved for type B vent. The draft inducer does not pressurize the exhaust.

Venting – Atmospheric Multiple Heaters

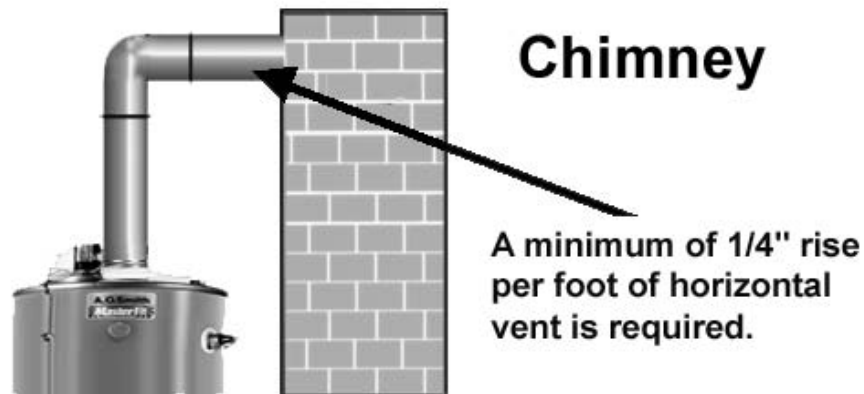

For larger applications, SBN water heaters can be common vented together, either in a tapered manifold or constant size manifold. Follow the National Fuel Gas Codes requirements for sizing and installation of fan-assisted products. SBN Models may be common vented only with other Category I appliances. See the Venting Section in the National Fuel Gas Code.

SBN TANK TYPE COMMERCIAL GAS WATER HEATER SERVICE HANDBOOK

When vents are combined, the area of the combined vent should be equal to area of the largest single vent, plus 50% of area of all others joining.

EXAMPLE: To combine two 6" vents with an 8" vent, the area of a combined vent should be one half area of two 6 inch vents (14 + 14) plus area of 8 inch vent (50) or 78 sq. inches. Referring to char, 78 sq. inches require 10" diameter vent.

Vent Size	Area in Square Inches	Vent Size	Area in Square Inches
5"	20	10"	79
6"	28	12"	113
7"	38	14"	154
8"	50	16"	201
9"	64	18"	254

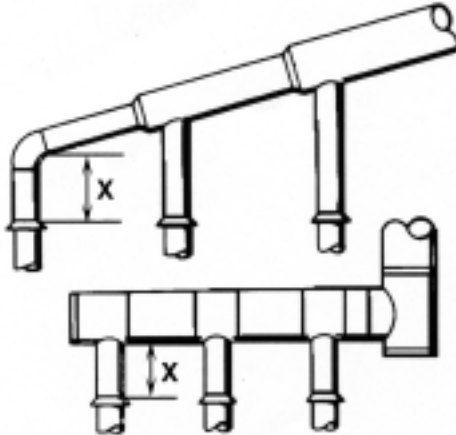

NINE RULES FOR GOOD VENTS

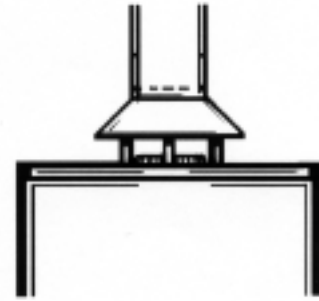

- The vent pipe should **ALWAYS** be the same size as the outlet of the draft diverter or factory supplied vent reducer.
 - Model SBN 120 are supplied with a 6" to 5" reducer.
 - Models SBD 250, 251 and 275 are supplied with a 8" to 6" reducer.

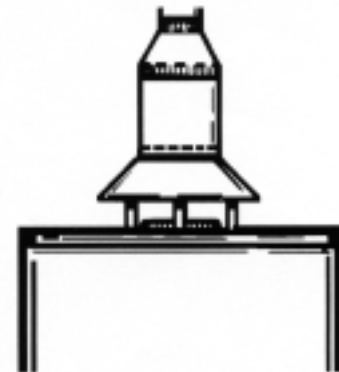

- The diameter of a vent pipe should **NEVER** be reduced, no matter what the circumstances.

SBN TANK TYPE COMMERCIAL GAS WATER HEATER SERVICE HANDBOOK

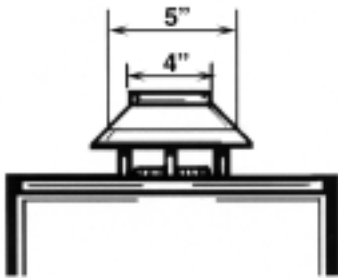

3. In some cases it may be necessary to run a vent larger than the draft diverter outlet.

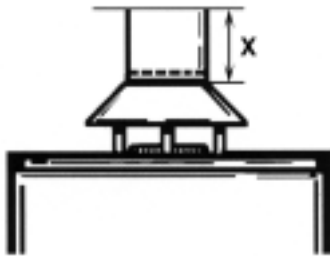
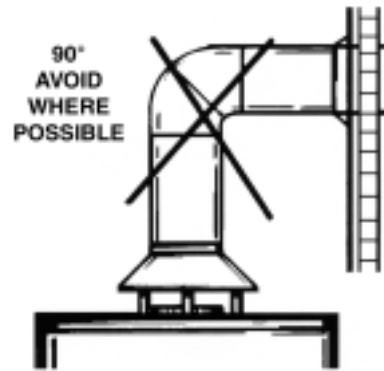

4. Take the maximum vertical rise possible immediately above the draft diverter.

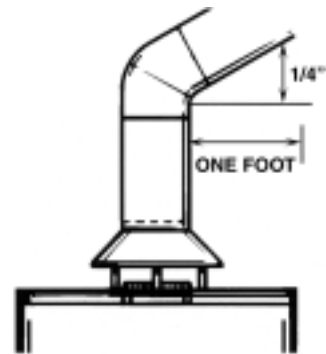

6. Horizontal pipe should be sloped upward at a minimum of $\frac{1}{4}$ " per foot.

5.

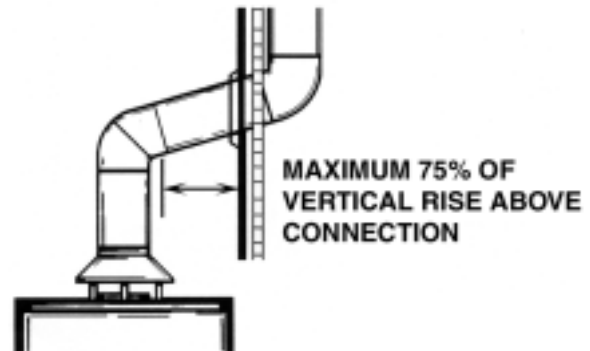
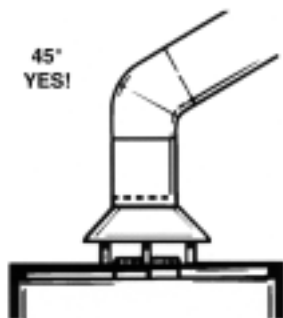

7. Horizontal elements should be limited to 75% of the vertical rise of the vent above the connection.

SBN TANK TYPE COMMERCIAL GAS WATER HEATER SERVICE HANDBOOK

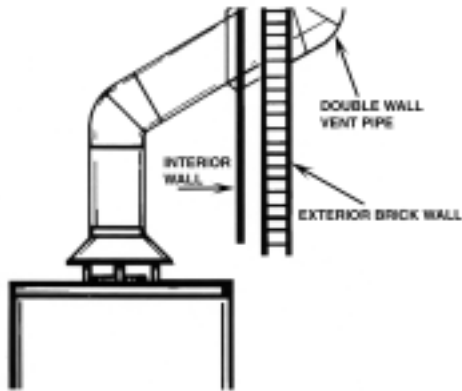

8. Flue gases must be kept hot for proper venting.

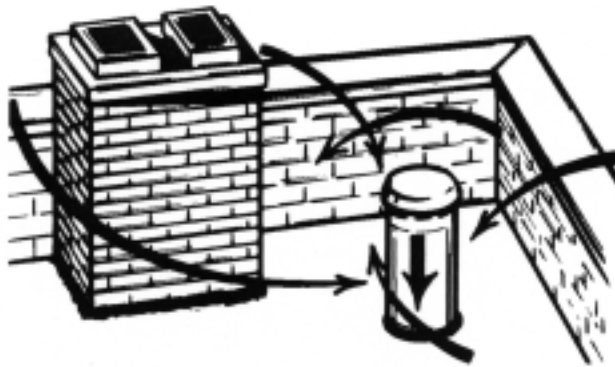

9. Obstructions can cause down drafts.

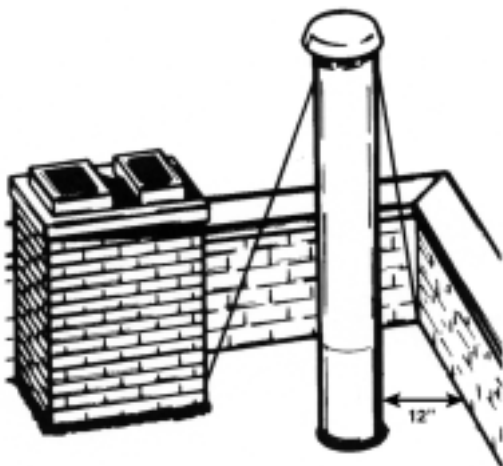

The vent pipe should be extended to meet local codes.

SBN TANK TYPE COMMERCIAL GAS WATER HEATER SERVICE HANDBOOK

TYPE B GAS VENT

Multiple Gas Fired Tank-Type Heaters

When venting multiple tank type heaters using Type B vent pipe, follow the installation diagram (figure 4) and tables below which give sizing and data based upon NFPA 54/ANSI Z223. 1992.

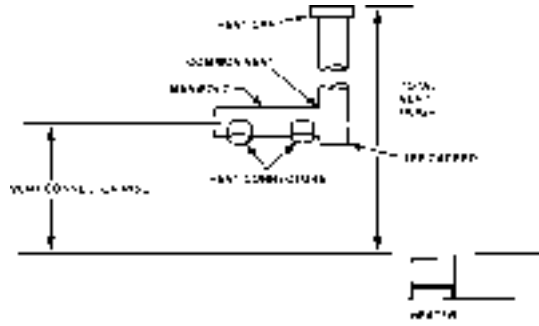

MODEL SBN 71-120NE										
Input: 120,000 Btu/hr										
Total Vent Height (Feet)										
Vent Connector Size: 5 inches										
			6	8	10	15	20	30	50	100
	Input Btu/hr	Rise	Vent Connector Diameter (Inches)							
	120,000	1 Ft.	6	6	5	5	5	5	5	5
	120,000	2 Ft.	5	5	5	5	5	5	5	5
	120,000	3 Ft.	5	5	5	5	5	5	5	5
Number of Heaters	Combined Input in Thousands of Btu/hr		Manifold and Common Vent Diameter (Inches)							
2	240,000		7	7	6	6	6	6	6	6
3	360,000		8	8	7	7	7	6	6	6
4	480,000		9	9	9	8	8	7	7	6
MODEL SBN 81-154NE										
Input: 154,000 Btu/hr										
Total Vent Height (Feet)										
Vent Connector Size: 6 inches										
			6	8	10	15	20	30	50	100
	Input Btu/hr	Rise	Vent Connector Diameter (Inches)							
	154,000	1 Ft.	6	6	6	6	6	6	6	6
	154,000	2 Ft.	6	6	6	6	6	6	6	6
	154,000	3 Ft.	6	6	6	6	6	6	6	6
Number of Heaters	Combined Input in Thousands of Btu/hr		Manifold and Common Vent Diameter (Inches)							
2	308,000		7	7	6	6	6	6	6	6
3	462,000		8	8	7	7	7	6	6	6
4	616,000		9	9	9	8	8	7	7	6
MODEL SBN 81-180NE, SBN 100-199NE										
Input: 180,000, 190,000 and 199,000 Btu/hr										
Total Vent Height (Feet)										
Vent Connector Size: 6 inches										
			6	8	10	15	20	30	50	100
	Input Btu/hr	Rise	Vent Connector Diameter (Inches)							
	180,000	1 Ft.	7	7	6	6	6	6	6	6
	190,000	1 Ft.	7	7	7	6	6	6	6	6
	199,000	1 Ft.	7	7	7	6	6	6	6	6
	180,000	2 Ft.	6	6	6	6	6	6	6	6
	190,000	2 Ft.	7	6	6	6	6	6	6	6
	199,000	2 Ft.	7	7	6	6	6	6	6	6
	180,000	3 Ft.	6	6	6	6	6	6	6	6
	190,000	3 Ft.	6	6	6	6	6	6	6	6
	199,000	3 Ft.	6	6	6	6	6	6	6	6
Number of Heaters	Combined Input in Thousands of Btu/hr		Manifold & Common Vent Diameter (Inches)							
2	360,000		7	7	6	6	6	6	6	6
	380,000		7	7	7	6	6	6	6	6
	398,000		6	7	7	6	6	6	6	6
	540,000		7	6	6	6	6	6	6	6
3	570,000		7	6	6	6	6	6	6	6
	597,000		6	7	6	6	6	6	6	6
	720,000		6	6	6	6	6	6	6	6
4	760,000		6	6	6	6	6	6	6	6
	796,000		6	6	6	6	6	6	6	6

SBN TANK TYPE COMMERCIAL GAS WATER HEATER SERVICE HANDBOOK

MODEL SBN 100-250NE			TECHNICAL DATA VENTING (Continued)							
Input: 250,000 Btu/hr			Total Vent Height (Feet)							
Vent Connector Size: 6 inches			6 8 10 15 20 30 50 100							
	Input Btu/hr	Rise	Vent Connector Diameter (Inches)							
	250,000	1 Ft	8	8	7	7	7	6	6	6
	250,000	2 Ft	7	7	7	7	6	6	6	6
	250,000	3 Ft	7	7	7	7	6	6	6	6
Number of Heaters	Combined Input in Thousands of Btu/hr	Manifold and Common Vent Diameter (Inches)								
2	500,000	9	9	9	8	8	7	7	7	
3	750,000	12	12	10	10	10	9	8	8	
4	1,000,000	14	14	12	12	10	10	9	9	
MODEL SBN 100-275NE										
Input: 275,000 Btu/hr			Total Vent Height (Feet)							
Vent Connector Size: 6 inches			6 8 10 15 20 30 50 100							
	Input Btu/hr	Rise	Vent Connector Diameter (Inches)							
	275,000	1 Ft	8	8	7	7	6	6	6	6
	275,000	2 Ft	8	8	7	7	6	6	6	6
	275,000	3 Ft	7	7	7	7	6	6	6	6
Number of Heaters	Combined Input in Thousands of Btu/hr	Manifold and Common Vent Diameter (Inches)								
2	550,000	10	9	9	8	8	8	7	7	
3	825,000	12	12	12	10	9	9	8	8	
4	1,100,000	14	14	14	12	12	10	9	9	
MODEL SBN 85-310										
Input: 310,000 Btu/hr			Total Vent Height (Feet)							
Vent Connector Size: 6 inches			6 8 10 15 20 30 50 100							
	Input Btu/hr	Rise	Vent Connector Diameter (Inches)							
	310,000	1 Ft	9	8	8	8	7	7	6	6
	310,000	2 Ft	8	8	8	7	7	7	6	6
	310,000	3 Ft	8	8	8	7	7	7	6	6
Number of Heaters	Combined Input in Thousands of Btu/hr	Manifold & Common Vent Diameter								
2	620,000	10	10	9	9	8	8	7	7	
3	930,000	14	12	12	12	10	9	9	8	
4	1,240,000	14	14	14	12	12	12	10	9	
MODEL SBN 85-366NE, SBN 85-390NE										
Input: 366,000, 399,000 Btu/hr			Total Vent Height (Feet)							
Vent Connector Size: 6 inches			6 8 10 15 20 30 50 100							
	Input Btu/hr	Rise	Vent Connector Diameter (Inches)							
	366,000	1 Ft	9	9	9	8	8	8	8	8
	399,000	1 Ft	10	9	9	9	8	8	8	8
	366,000	2 Ft	9	9	8	8	8	8	8	8
	399,000	2 Ft	9	9	9	8	8	8	8	8
	366,000	3 Ft	9	8	8	8	8	8	8	8
399,000	3 Ft	9	9	8	8	8	8	8	8	
Number of Heaters	Combined Input in Thousands of Btu/hr	Manifold & Common Vent Diameter (Inches)								
2	732,000	12	10	10	9	9	9	8	8	
3	798,000	12	12	10	10	9	9	8	8	
4	1,098,000	14	14	14	12	12	10	9	9	
3	1,197,000	14	14	14	12	12	10	10	9	
4	1,464,000	16	16	14	14	14	12	12	10	
4	1,596,000	16	16	16	14	14	12	12	10	

SBN TANK TYPE COMMERCIAL GAS WATER HEATER SERVICE HANDBOOK

SBN SEQUENCE OF OPERATION

Sequence

1. Thermistors (probes) call for heat.
2. Inducer fan starts and provides draft.
3. Hot surface igniter = 20 sec. warmup.
4. Main gas valve opens 4 sec. trial for ignition. (Maximum 5 trials.)
5. Main burner ignites and proves.
6. Thermistors reach the temperature setting.
7. Main burners "OFF"
 - Auto restart after 60 min.
 - 20 sec blower "interpurge" between trials

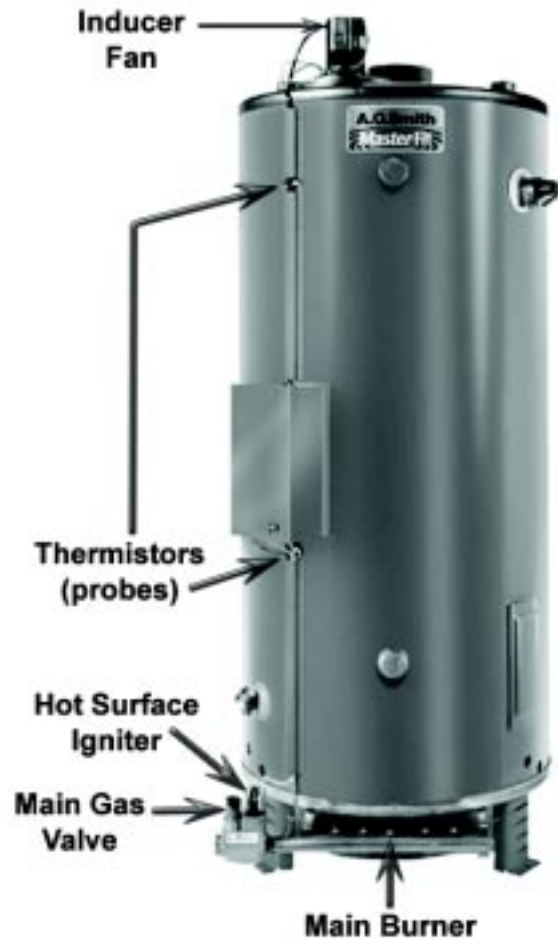

Top View

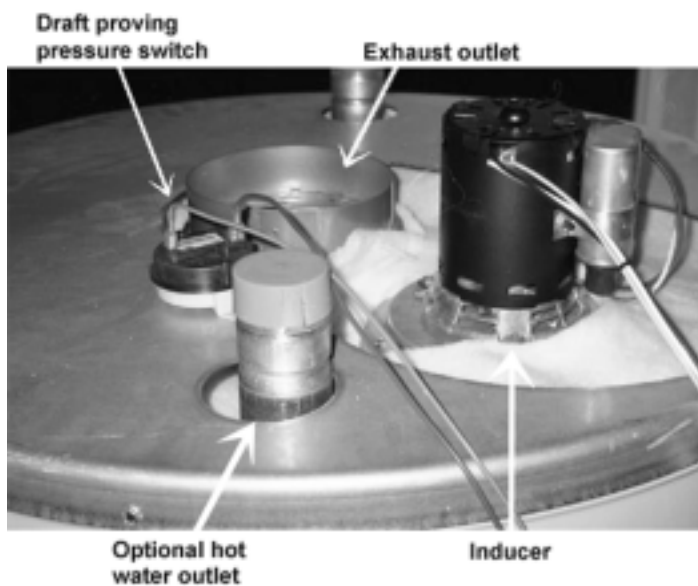

Draft Proving (Pressure) Switch Table		
SBN Models	Part No.	Pressure Setting To Close Switch (Inches W.C.)
366	194411-0	(-) 1.60" ± .10"
275	194411-1	(-) 2.00" ± .10"
310	194411-2	(-) 1.75" ± .10"
120, 199, 250, 400	194411-3	(-) 2.40" ± .10"
154, 180, 199	194411-4	(-) 2.60" ± .10"

SBN TANK TYPE COMMERCIAL GAS WATER HEATER
SERVICE HANDBOOK

FRONT VIEW OF WATER HEATER

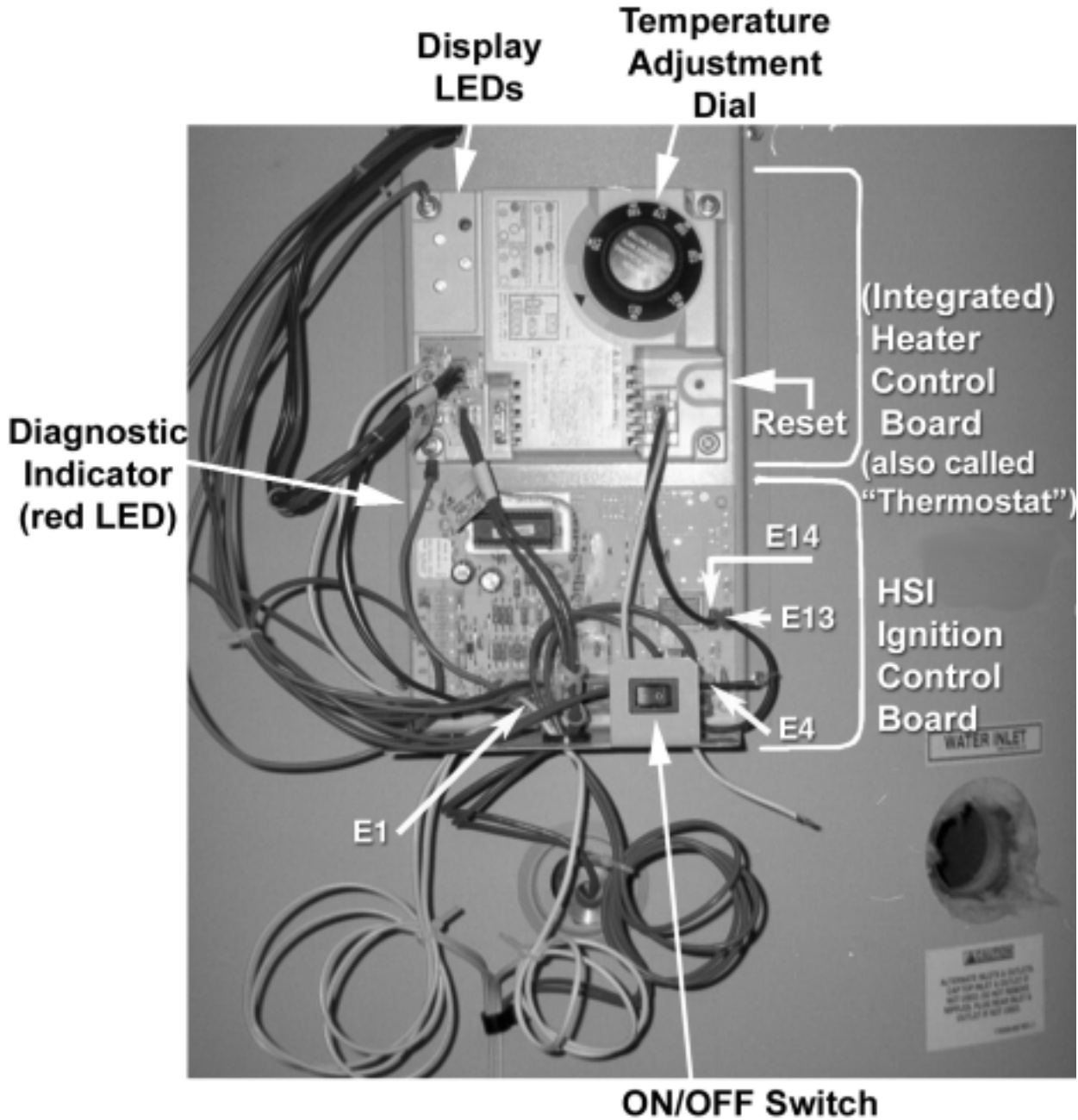

SBN TANK TYPE COMMERCIAL GAS WATER HEATER
SERVICE HANDBOOK

**WHITE ROGERS INTEGRATED WATER HEATER CONTROL
(PART NO. 194393-0) - ALSO CALLED "THERMOSAT"**

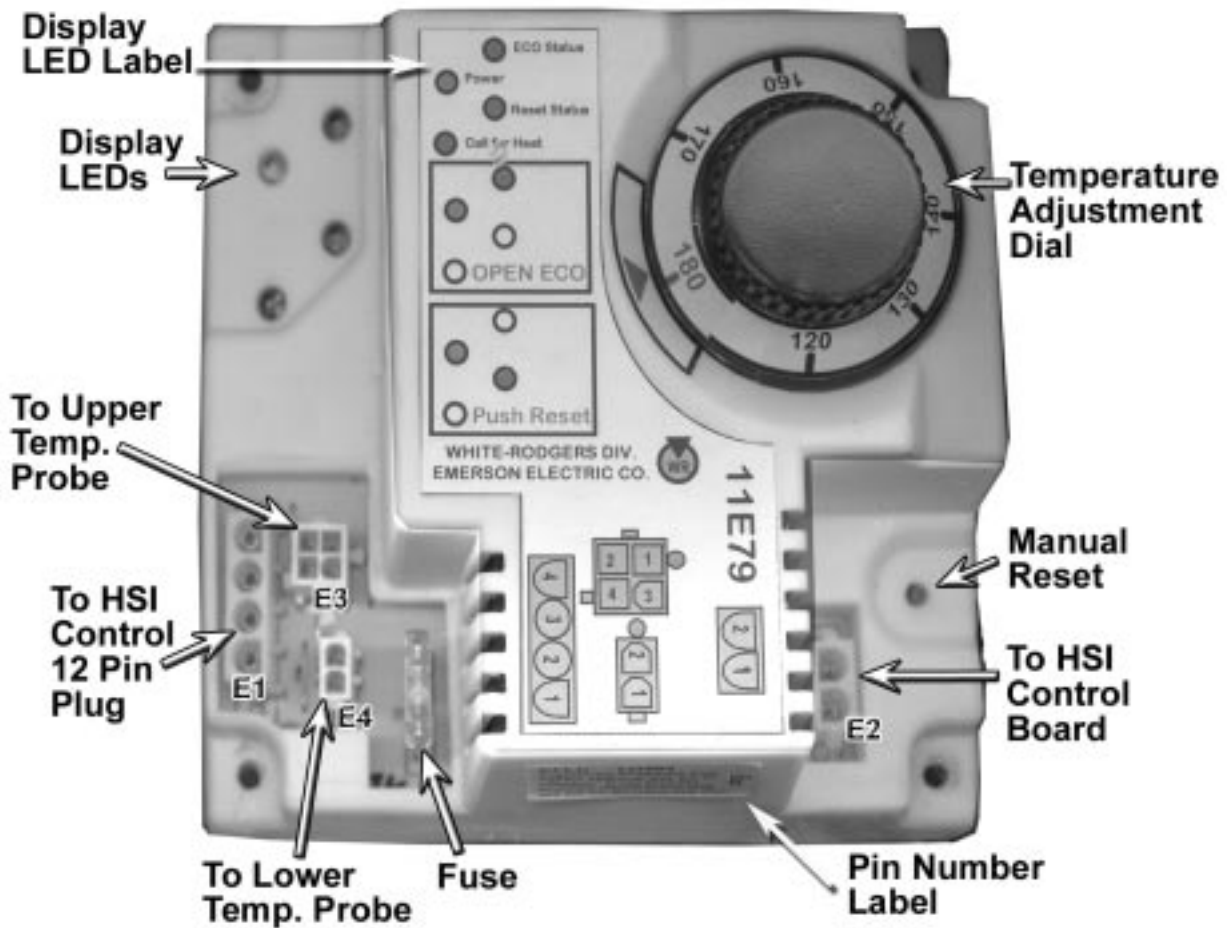

SBN TANK TYPE COMMERCIAL GAS WATER HEATER SERVICE HANDBOOK

HSI INTEGRATED IGNITION CONTROL BOARD (PART NO. 194392)

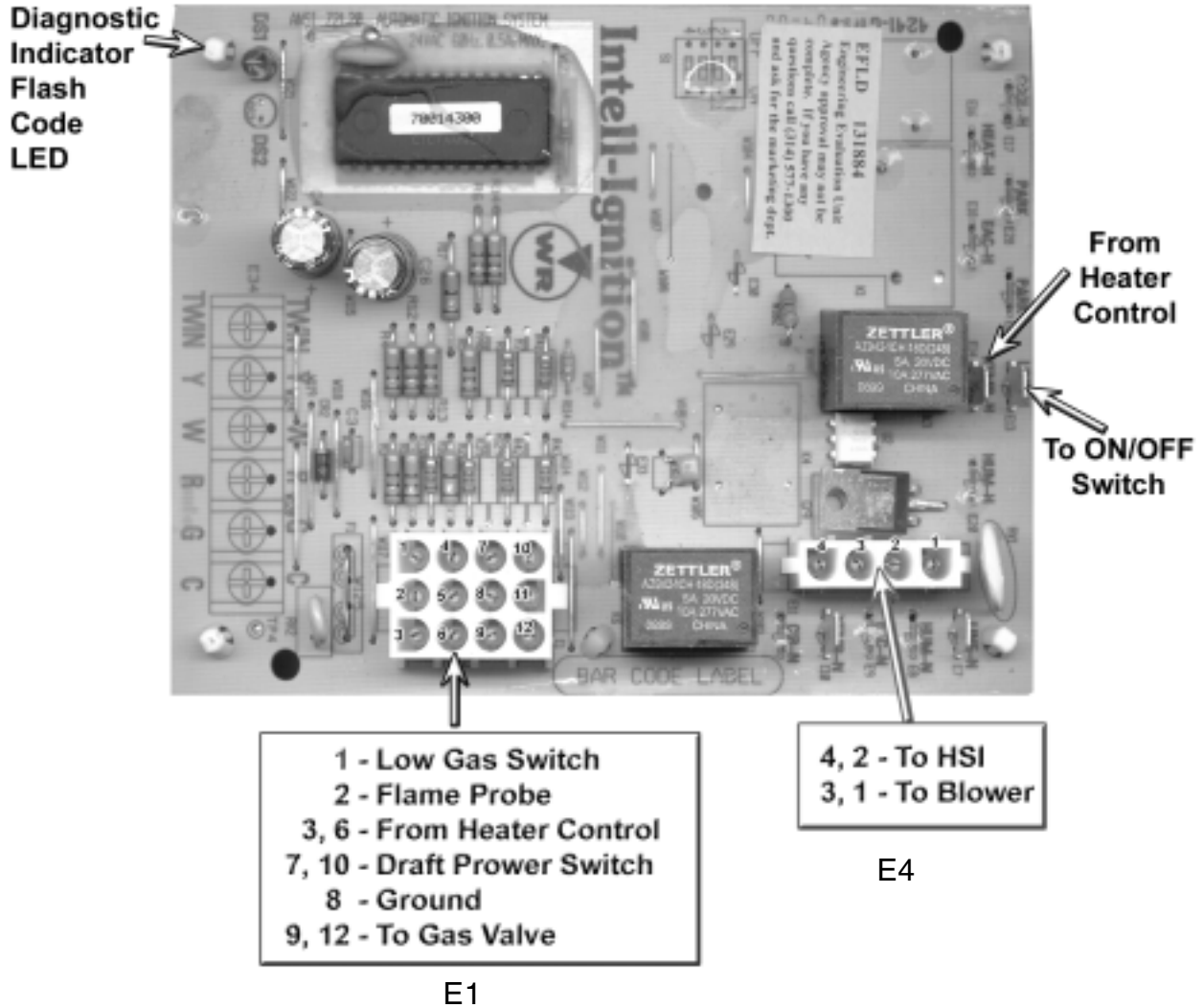

SBN TANK TYPE COMMERCIAL GAS WATER HEATER SERVICE HANDBOOK

LOWER FRONT VIEW OF SBN WATER HEATER

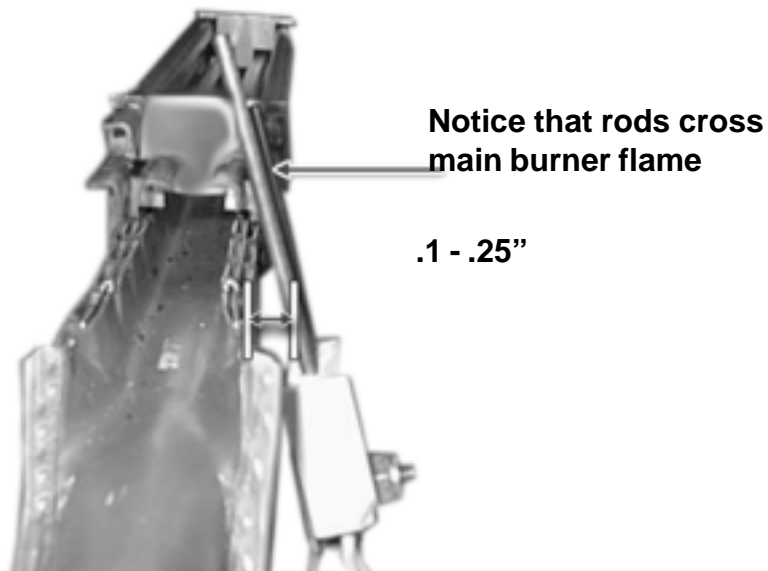
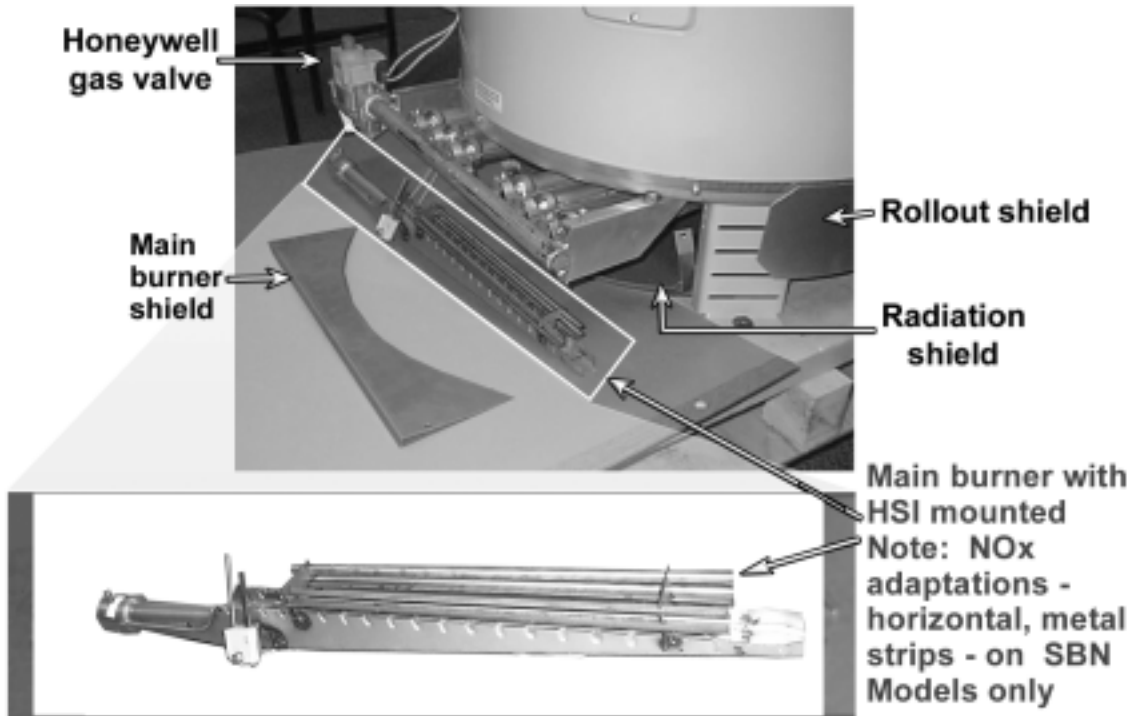

HSI	
Part Number	194405
Volts AC	Nominal 80 VAC
Ohms Resistance	11.0 - 20.0 @ 77° F (25° C)

SBN TANK TYPE COMMERCIAL GAS WATER HEATER SERVICE HANDBOOK

WIRING DIAGRAM

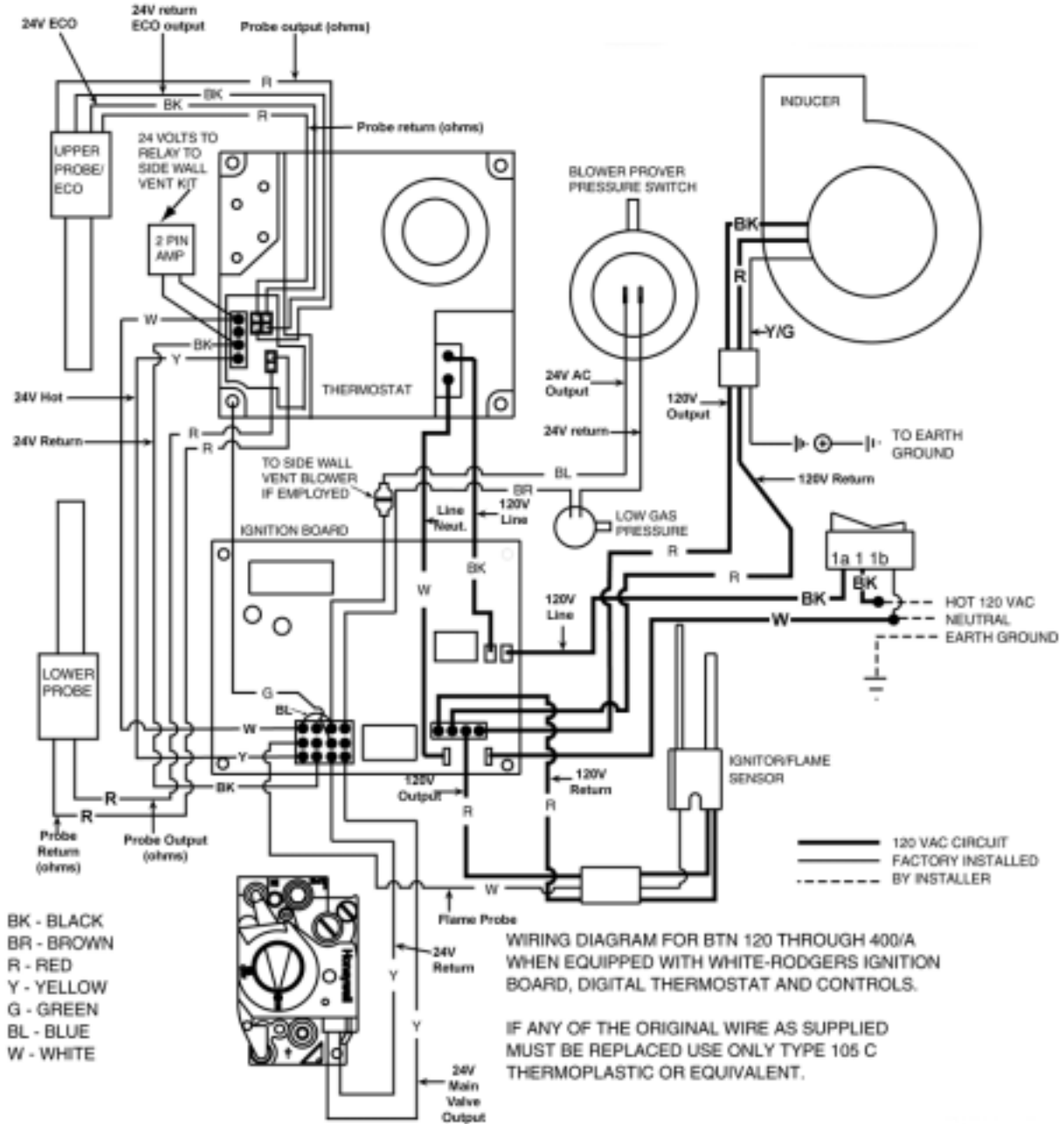
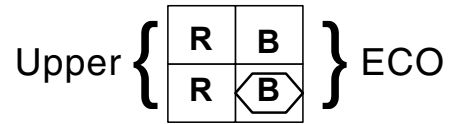

Propane (series) models do not have a low gas pressure switch.

SBN TANK TYPE COMMERCIAL GAS WATER HEATER SERVICE HANDBOOK

ELECTRICAL SEQUENCE OF SBN WATER HEATER OPERATION

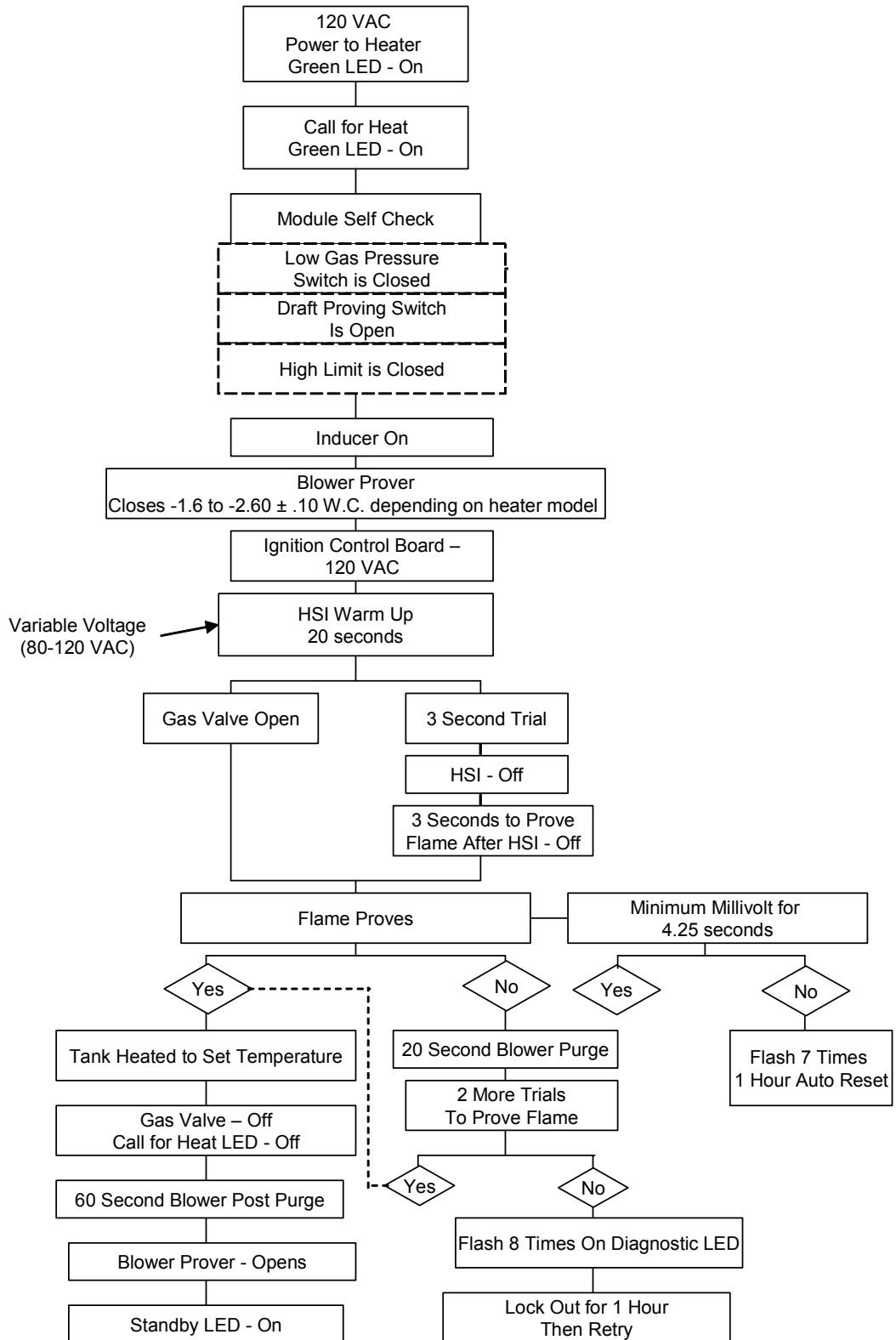

**SBN TANK TYPE COMMERCIAL GAS WATER HEATER
SERVICE HANDBOOK**

PRE-SERVICE CHECKLIST

Use the following checklist **BEFORE** you begin servicing the water heater.

- | | |
|---|----------|
| 1. Have you removed the cover from the controls? | Yes / No |
| _____ | |
| Did you take notice of the status lights on the upper water heater control? | Yes / No |
| _____ | |
| Did you take notice of the red LED in the upper left corner of the lower ignition control? | Yes / No |
| _____ | |
| 2. Did you note conditions of the room? | Yes / No |
| _____ | |
| Where does the supply air come from? | Yes / No |
| _____ | |
| Is the room clean? | Yes / No |
| _____ | |
| What is stored with the heater? | Yes / No |
| _____ | |
| How is the heater vented? | Yes / No |
| _____ | |
| Are all water and gas shut-off valves open? | Yes / No |
| _____ | |
| Are there room exhaust or air intake fans? | Yes / No |
| _____ | |
| 3. Did you note the condition of the water heater? | Yes / No |
| _____ | |
| Is the ON/OFF switch "On"? | Yes / No |
| _____ | |
| What is the temperature of the stored water? (Test at T&P valve or nearby faucet.) | |
| _____ | |
| Is the thermal expansion tank installed? | Yes / No |
| _____ | |
| 4. Did you write down the complete model and serial numbers of the water heater? If so, what are they? | Yes / No |
| _____ | |
| 5. Does the water heater have a good ground wire connection? If not, the inducer will typically come on for a short time (3-5 seconds), then go off, and the red LED will flash 8 times. | Yes / No |

SBN TANK TYPE COMMERCIAL GAS WATER HEATER SERVICE HANDBOOK

CONTROL BOARD DIAGNOSTIC LED INTERPRETATION AND TROUBLESHOOTING

TEST 1 - 120 VAC CHECK TO WATER HEATER

Conditions:

- No Green display "Power" LED on.
- Plugs are in receptacles.
- Supply power breaker is not "open"
- On/Off heater switch is "On".

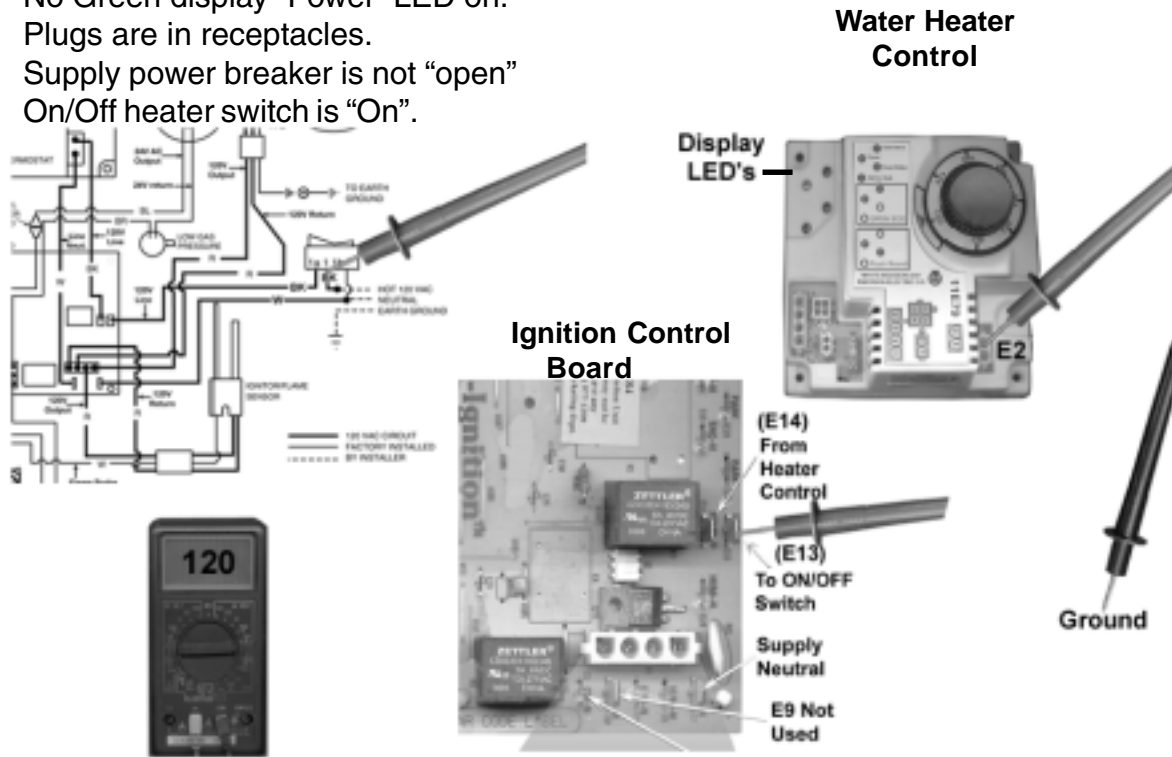

TEST 1	120 Vac Check To Water Heater On Switch
	<ul style="list-style-type: none"> ♦Check for 115-125 VAC black wire to ground ♦115 V check to E13 terminal and 2B receptical.

If...	...then
voltage is not present from on/off switch-center black wire to ground	<ul style="list-style-type: none"> ♦check conditions above ♦check wiring from switch to break box
power is present from center on/off terminal	check power from on/off to ignition board term E13.
voltage is not present at E13 to ground	<ul style="list-style-type: none"> ♦check wiring from on/off. Left-outside terminal to E13. ♦replace on/off switch.
power is present at E13	check power from E14 to heater control E2 receptacle
voltage is not present from heater control receptacle E2 black to ground	<ul style="list-style-type: none"> ♦check wiring from ignition control board E14 to heater control receptacle E2. ♦replace ignition control board.
power is present at E2	green LED should be on.

SBN TANK TYPE COMMERCIAL GAS WATER HEATER SERVICE HANDBOOK

FLASH CODES OF DIAGNOSTIC INDICATOR

Conditions:

- Power On
- Red, heater control “Call for Heat” LED – on
- Red, ignition control board diagnostic LED – Flashing
- Note LED Flash Code before resetting heater.

LED Status	Indication
1 Flash	System is in lock out.
2 Flashes	Draft proving (pressure) switch failed to open within 5 seconds at the end of the last cycle.
3 Flashes	Draft proving (pressure) switch failed to close (-2.1 inches of water column pressure) within 5 seconds after the inducer was started. The low gas pressure switch (closes at 5.2" ± .04" w.c.) may have remained open.
4 Flashes	Open on high temperature limit switch (ECO).
6 Flashes	115-volt supply power connection is indicating reversed polarity.
7 Flashes	Flame sensor reads a low flame signal for more than 4.25 sec.
8 Flashes	No ignition sensed.
Continuous Flash	Continuous flame sensed for more than 5 seconds without gas valve being energized.
Continuous ON	Internal control board failure.

*Control system self adjusts to use a minimum voltage for ignition. Lower voltage results in lower igniter temperature which results in longer igniter life. Igniter voltage may vary from Nominal 80 VAC.

TEST 2 - POLARITY CHECK

Conditions:

- No hot water
- Green “Power” LED is on.
- Tank is more than 5° F below temperature dial setting.
- Red ignition control board diagnostic LED is flashing 6 times between pauses.
- Red, diagnostic “Call for Heat” LED-OFF.

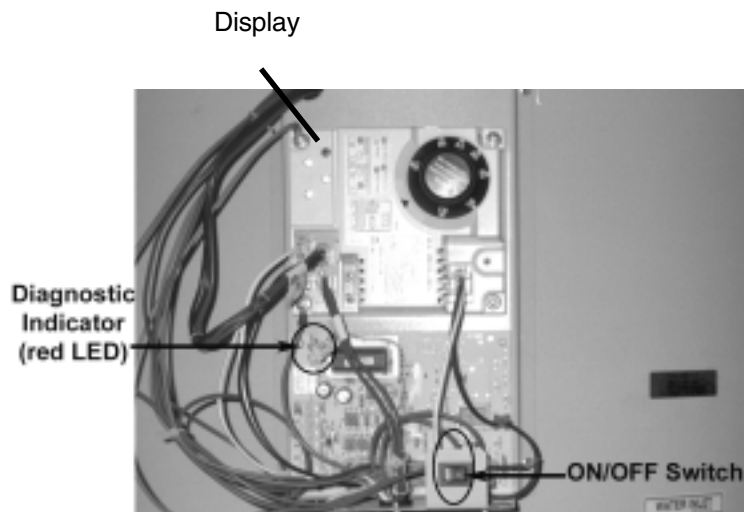

LED's

Continued on next page

SBN TANK TYPE COMMERCIAL GAS WATER HEATER SERVICE HANDBOOK

TEST 2 - POLARITY CHECK - continued

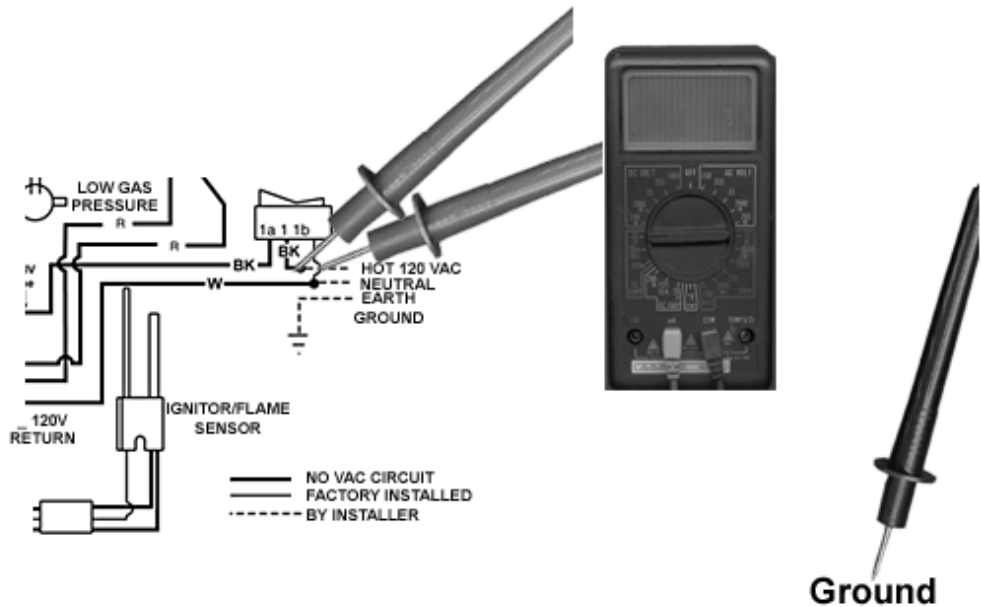

TEST 2	Polarity Check
	Check from on/off switch center and white wire terminals to ground
If...	...then
115-125 VAC is not present	see Test 1.
voltage is present white (right terminal) to ground but not black (center terminal) to ground	reverse supply wire connections - polarity is reversed.

TEST 3 - CONTINUITY CHECK OF HIGH LIMIT (ECO)

Conditions:

- Power On – No Hot Water
- Red, heater control “Call for Heat” LED – on
- Red, ignition control board diagnostic LED – 4 Flashing
- Note LED Flash Code before resetting heater.
- See Description of diagnostic LED Flashes.
- Turn Power “Off”

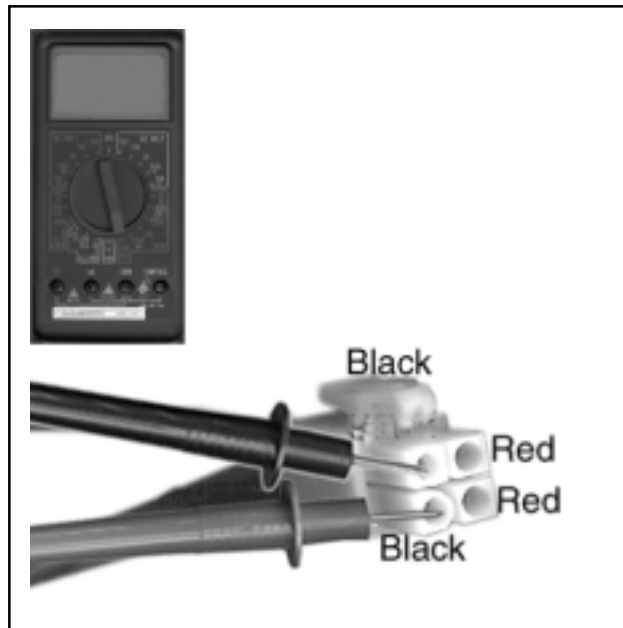

Continued on next page

**SBN TANK TYPE COMMERCIAL GAS WATER HEATER
SERVICE HANDBOOK**

TEST 3 - CONTINUITY CHECK OF HIGH LIMIT (ECO)-CONTINUED

TEST 3	Continuity check of ECO (energy cut-off, high limit)
	Black to Black wires of upper probe. Power is off.

If...	...then
continuity is indicated	opens at 203° F; closes at 193° F. If water is below 193° F, continuity is correct.
continuity is not present	replace ECO sensor, if water temperature is below 193° F.
water is less than 120° F	<ul style="list-style-type: none"> •reset status LED should be on. •replace heater control if control will not manually reset.

TEST 4 - UPPER TEMPERATURE PROBE CONTINUITY CHECK

Conditions:

- Power On - Water below temperature set point.
- Red, heater control "Reset Status" LED-OFF
- "Call For Heat" LED off.

Ohms Resistance Table

° F	Ohms
70°	11,884
120°	3,759
140°	2,488
180°	1,169

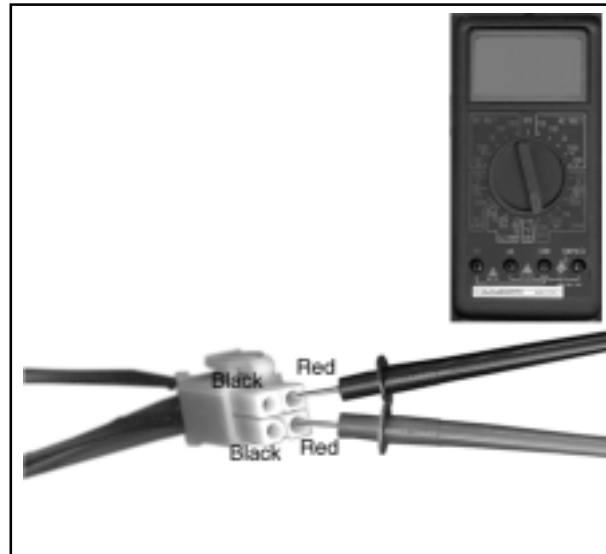

TEST 4	Upper Temperature probe continuity check
	Red wire to red wire - Turn supply power "Off" for this test

If...	...then
test indicates no continuity	replace probe.
continuity is indicated	probe should be okay (also verify Ohms resistance for water temperature). (Reading will be approximate.)

SBN TANK TYPE COMMERCIAL GAS WATER HEATER SERVICE HANDBOOK

TEST 5 - CALLING FOR HEAT – NO INDUCER OPERATION

Conditions:

- Power on
- Plugs in Receptacles
- Red “ Call for Heat” LED-ON
- Inducer “Off”

Note flash code on ignition control board diagnostic LED

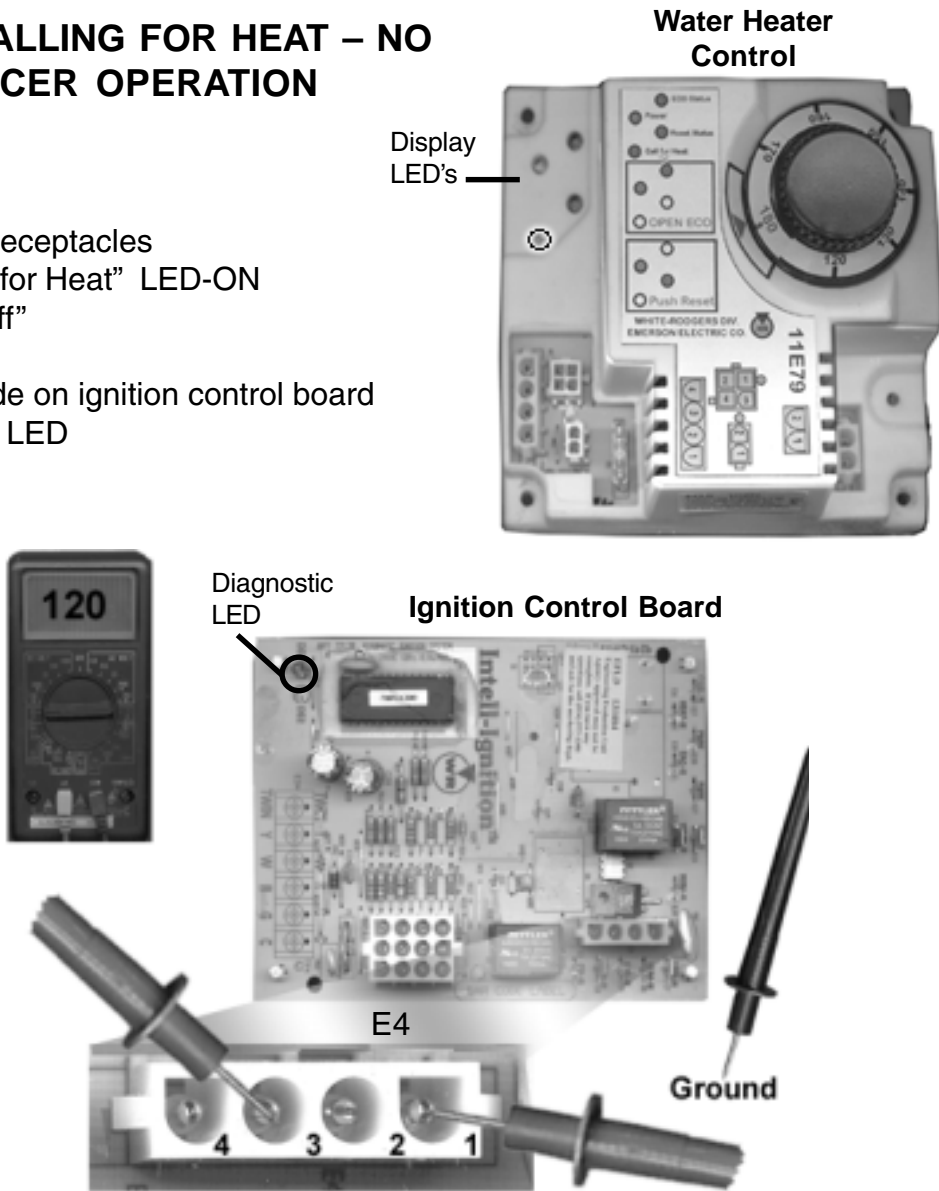

TEST 5	115-120 V Check to Inducer
	Test on Ignition Board 4 Pin Receptacle E4
If...	...then
pin 1 to ground check has no voltage	<ul style="list-style-type: none"> •reset control by interrupting power - note possible reasons for this from flashing LED code •replace ignition board
pin 1 to ground has voltage	proceed
pin 3 to ground has no voltage	<ul style="list-style-type: none"> •check wiring harness and plugs •replace inducer

SBN TANK TYPE COMMERCIAL GAS WATER HEATER SERVICE HANDBOOK

TEST 6 - INDUCER ON-NO IGNITION

Conditions:

- Power on
- Plugs in receptacles
- Inducer operating
- No power to Hot Surface Igniter (HSI)
- Note flash code of LED

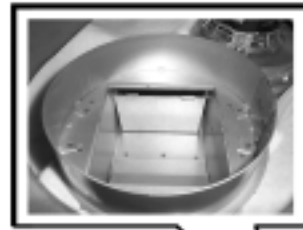
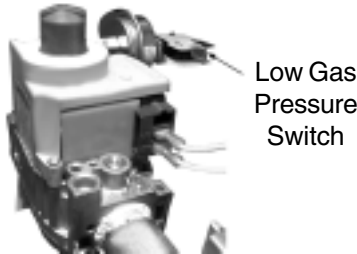
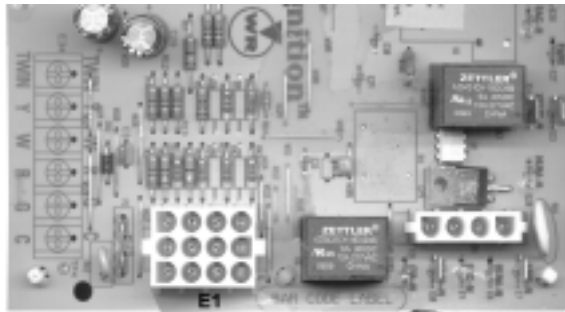

Draft Exhaust

Draft Proving Pressure Switch

Exhaust Outlet

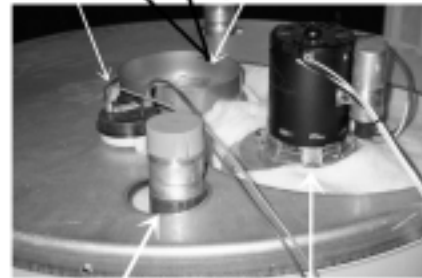

Optional Hot Water Outlet

Inducer

Low Gas Pressure Switch

TEST 6	24 VAC Check of Blower Prover/Low Gas Pressure Circuit
---------------	---

If...	...then
ignition board receptacles E1, Pin 7 to ground shows no voltage	replace ignition board
E1, Pin 7 has 24 Volt to ground	check wire connection to and from inducer
voltage check of each blower switch terminal to ground shows voltage to only 1 terminal	<ul style="list-style-type: none"> •switch is open - check for proper draft (should also see LED 3 flash code) •check for blocked exhaust •check that blower outlet exhaust damper is open •replace blower (draft) proving switch
24V is present from each switch terminal to ground.	<ul style="list-style-type: none"> •check wiring from blower switch to low gas pressure switch
voltage check to each terminal of low gas pressure switch and ground shows only voltage on 1 terminal	<ul style="list-style-type: none"> •switch is open - test for a minimum of 5.2 ± " W.C. Natural Gas or 10.5" Propane, flowing supply gas pressure (should also see 3 Flash LED code) •replace low gas pressure switch
voltage is present to each pressure switch terminal and ground	check wiring from low gas pressure switch to ignition board recetacles E1, Pin 10

SBN TANK TYPE COMMERCIAL GAS WATER HEATER SERVICE HANDBOOK

TEST 7 - INDUCER ON – PROVER SWITCH AND LOW GAS SWITCH CLOSED – NO IGNITER OPERATION

Conditions:

- Power on
 - Plugs in receptacles
 - Inducer on
 - 24V at ignition board
E1, Pin 10
 - No Power to igniter
- Note: Flash code of LED

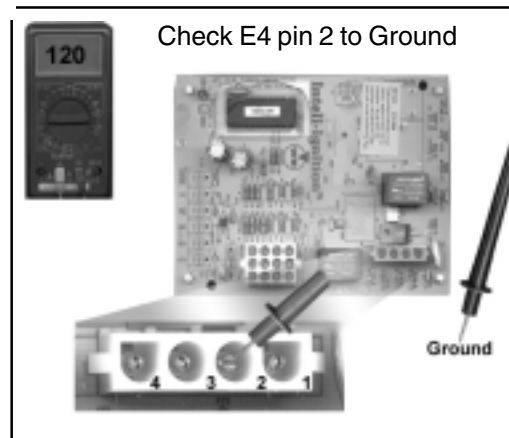
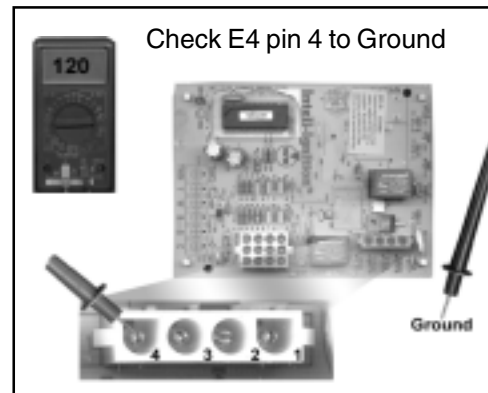
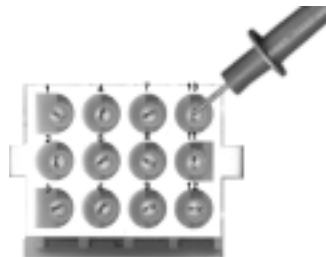

TEST 7	<p>Voltage check and continuity check of hot surface igniter circuit</p> <ul style="list-style-type: none"> ♦Continuity check - Power off- Plug removed from E4 receptacles ♦Nominal 80 VAC check - Plug in E4- Power "On"
---------------	---

If...	...then
continuity is not indicated between E4 plug pin 2 to 4.	<ul style="list-style-type: none"> ♦check wiring and connection from E4 plug to HSI receiving plug ♦replace HSI Assembly
continuity is present	♦resistance should be between 11 and 20 Ohms at a temperature of 77°F
voltage is not present between E4, Pin 2 to ground	♦replace ignition board
voltage is present	♦continue
voltage is not present between E4, Pin 4 to ground	<ul style="list-style-type: none"> ♦check wiring and plug connections to HSI ♦replace HSI
voltage is present	<ul style="list-style-type: none"> ♦note ignition board, Flash code LED ♦HSI should work

SBN TANK TYPE COMMERCIAL GAS WATER HEATER SERVICE HANDBOOK

TEST 8 - IGNITER HEATS – NO MAIN BURNER

Conditions:

- Plugs in receptacle
- Igniter energizes (gets red)
- No main burner or main shuts off within 5 seconds.

Note flash code of LED.

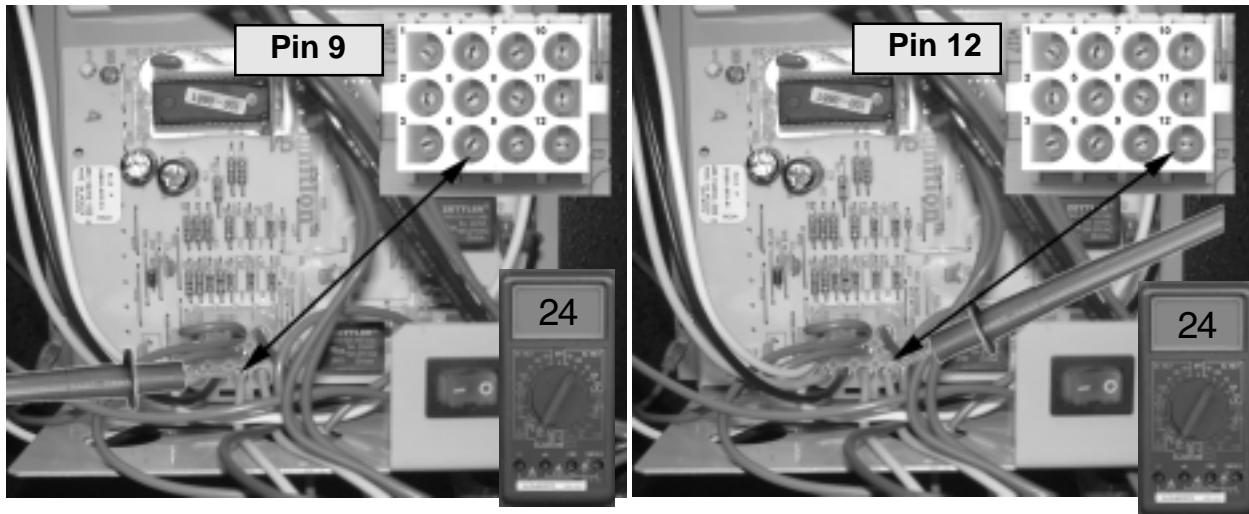

E1 Plug, Pin 9
Plug in Receptacle

E1 Plug, Pin 12
Plug in Receptacle

TEST 8	Test of Igniter and gas valve circuit
If...	...then
short heat up time of igniter	<ul style="list-style-type: none"> • check control box grounding
normal (Approximate 20 seconds) warm up - no ignition	<ul style="list-style-type: none"> • check for 24V from E1, Pin 12 to ground during 4 second trial. - Yes - Continue - No - Replace Ignition Board
no voltage present E4, Pin 12 to ground	replace ignition board
24 Volt was present from E1, Pin 12 to ground, but no main burner	<ul style="list-style-type: none"> • check that air has been purged from gas circuit • check that wiring and connections to gas valve and E1, Pin 9 are correct • check for 24 VAC at E1, Pin 9 to ground during 4 second trial

SBN TANK TYPE COMMERCIAL GAS WATER HEATER SERVICE HANDBOOK

TEST 9 - IGNITER HEATS – NO MAIN BURNER

Conditions:

- Test 8 completed then:
- Turn off power
- Disconnect wires from gas valves

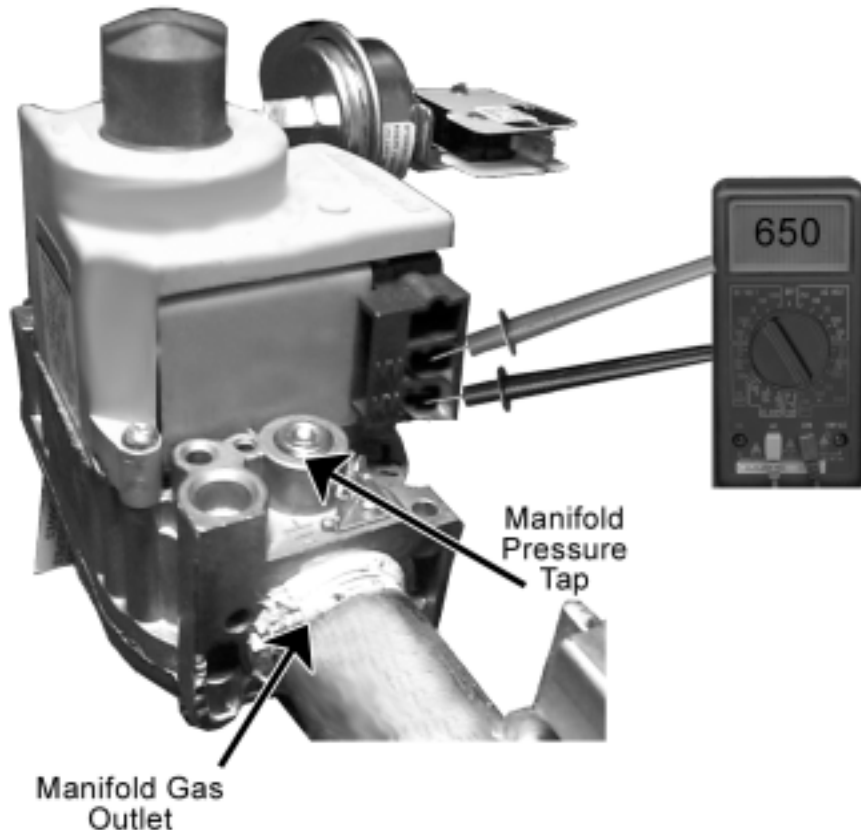

TEST 9	Continuity Check Of Gas Valve Coil
---------------	---

If...	...then
meter reads 0 or 1	<ul style="list-style-type: none"> ♦check meter scale setting to read between 550 and 650 Ohms ♦replace Gas Valve
meter indicates pilot and main coil have continuity	<ul style="list-style-type: none"> ♦valve should be okay ♦still no gas to main burner, then coil may be stuck - Replace Valve

SBN TANK TYPE COMMERCIAL GAS WATER HEATER SERVICE HANDBOOK

TEST 10 - MAIN BURNER IGNITION FOR LESS THAN 5 SECONDS

Conditions:

- Power On – plug connected
- Main Burner ignites for approximately 5 seconds then goes out.
- Tests 8 and 9 completed
- Note flash code on ignition board LED.

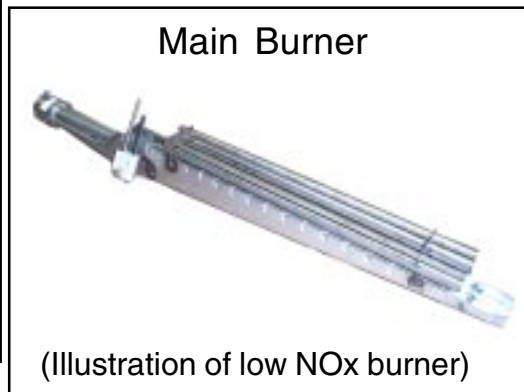
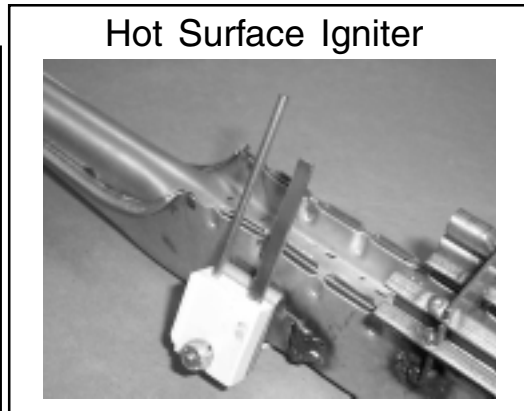
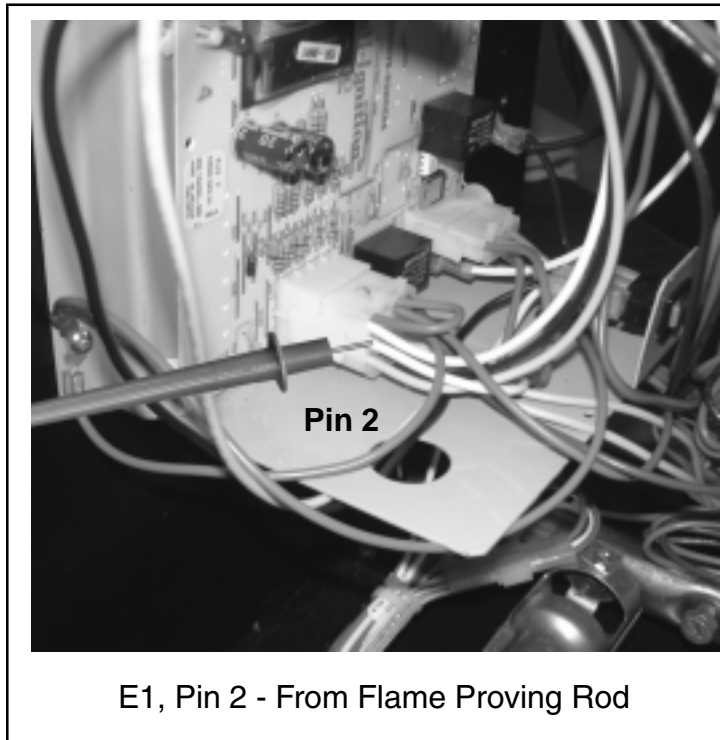

TEST 10	Flame Prover Circuit Check
----------------	-----------------------------------

If...	...then
no extended main burner ignition	<ul style="list-style-type: none"> ♦check wiring and plug connections of HSI assembly plug and ignition board receptacles E1, Pin 2 ♦check that HSI assembly is not cracked or dirty ♦check that flame prover will be in main flame ♦replace HSI assembly
still no extended main burner ignition	replace ignition control board

SBN TANK TYPE COMMERCIAL GAS WATER HEATER SERVICE HANDBOOK

TEST 11 - WATER HEATER SHUTTING OFF BELOW SETTING

Conditions:

- Main burner ignited
- Stored water is below temperature setting more than 5° F (Tank Average).
- Power off
- Plug disconnected from heater control board receptacle E3 and E4

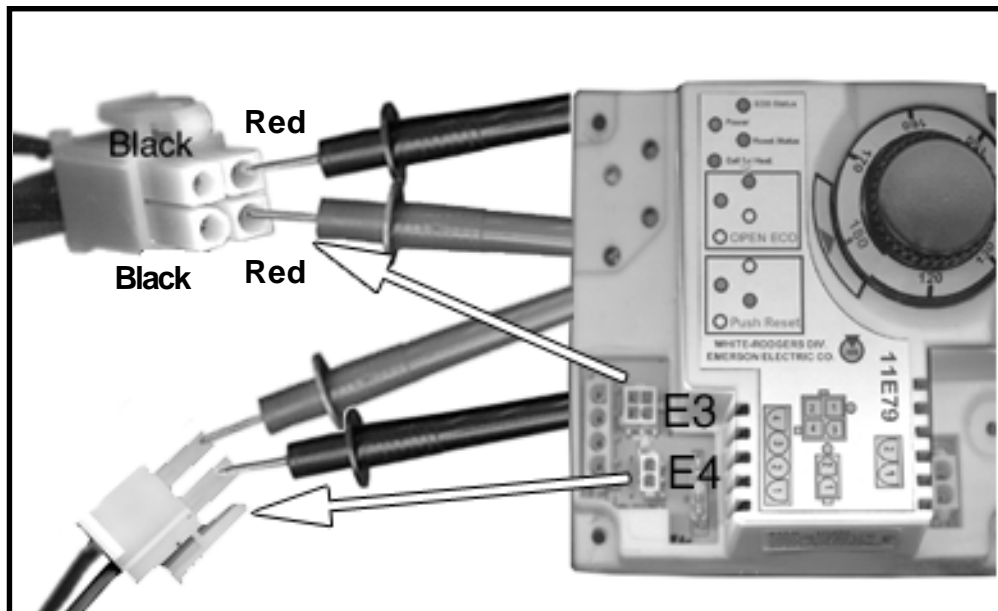



TEST 11	Water Temperature Circuit Check - Continuity
----------------	---

If...	...then
continuity check pin to pin of lower temperature probe shows 1 or 0 (E4)	<ul style="list-style-type: none"> ♦see Test 4 ♦check wiring and plug connections to heater control board receptacle E4 ♦replace lower temperature probe
continuity check red wire pin to red wire pin on upper temperature sensor shows 1 or 0 (E3)	<ul style="list-style-type: none"> ♦see Test 4 ♦check wiring and plug connections to heater control board receptacle ♦replace upper temperature probe
all above checks are okay	replace the water heater control.

SBN TANK TYPE COMMERCIAL GAS WATER HEATER SERVICE HANDBOOK

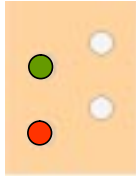
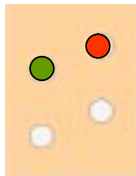
DISPLAY LIGHTS ON INTEGRATED HEATER CONTROL

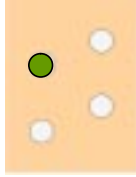
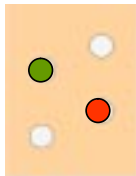
LED Status	Indication	Action to be Taken
	Calling for heat	Normal status – none
	The ECO (Energy Cut Off) has opened.	<ul style="list-style-type: none"> •Check for excessively hot water (203° F or higher). •Correct the problem
	No power	Check the breaker.
	Tank is at a set temperature of $\pm 2^\circ$ F.	
	Tank has cooled below 120° F Preceded by “ECO Open” indication	<ul style="list-style-type: none"> •Push the manual reset button. •Troubleshoot for “why” the ECO opened

**SBN TANK TYPE COMMERCIAL GAS WATER HEATER
SERVICE HANDBOOK**

**LED INDICATORS ON HOT SURFACE IGNITION (HSI)
USING FLASHING RED LED ON HSI (HOT SURFACE IGNITION)**

LED STATUS	INDICATION	ACTION TO BE TAKEN
1 Flash	System is in lockout.	Interrupt power to reset. Heater had not sensed the flame – check gas supply and igniter condition.
2 Flashes	Draft proving (pressure) switch (closes at -2.10 +0.01 inches W.C. negative pressure) failed to open within 5 seconds at the end of the last cycle.	Test for defective switch or a pressurized room condition that may be forcing air through the inducer.
3 Flashes	Draft proving (pressure) switch failed to close within 5 seconds after the inducer was started.	Check the draft. The low gas pressure switch closes at 5.2 inches W.C. may have remained open. Verify the supply gas pressure while the gas is flowing.
4 Flashes	Open on high temperature limit switch (ECO)	Check temperature control operation.
6 Flashes	115-volt supply power connection is indicating reversed polarity.	Verify that a neutral-to-ground check results in “0” volts and a hot-to-ground check results in 115-125 VAC.

**SBN TANK TYPE COMMERCIAL GAS WATER HEATER
SERVICE HANDBOOK**

**LED INDICATORS ON HOT SURFACE IGNITION (HSI)
USING FLASHING RED LED ON HSI (HOT SURFACE IGNITION)**

LED STATUS	INDICATION	ACTION TO BE TAKEN
7 Flashes	Flame sensor reads a low flame signal for more than 4.25 sec.	<ul style="list-style-type: none"> • Verify that the main burner flame is in contact with the flame. • Check wiring and connection to HSI assembly. • Clean the flame sensor rod of soot or metal flakes.
8 Flashes	No ignition sensed	<ul style="list-style-type: none"> • Check igniter for lack of voltage, cracks, or lose connection. [11-20 Ohms at 77° F (25° C) is "good"] • Check ground connection.
Continuous Flash	Continuous flame sensed for more than 5 seconds without gas valve being energized	Check that the gas valve is not failing to close at the end of a heating cycle.
Continuous ON	Internal control board failure.	Replace ignition control board.

SBN TANK TYPE COMMERCIAL GAS WATER HEATER
SERVICE HANDBOOK

PART LOCATIONS ON SBN SERIES 120,000 - 390,000 BTU/H INPUT
MODELS 120 THROUGH 400/A

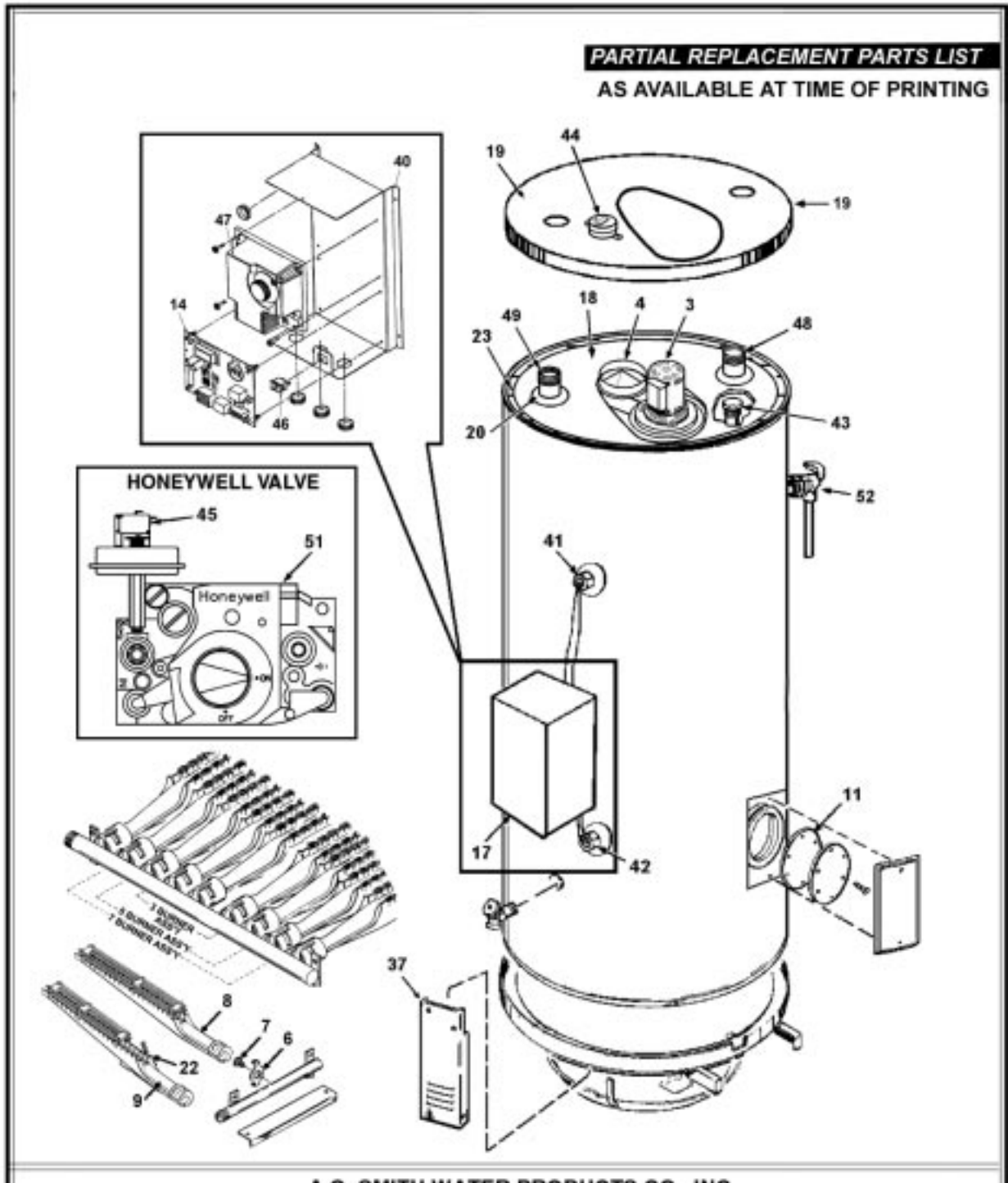

www.stateind.com

SBN TANK TYPE COMMERCIAL GAS WATER HEATER SERVICE HANDBOOK

	120	154	180	199	200(A)
Blower Assembly:					
3	Blower	194408	194408	194408	194408
4	Outlet Assembly, Exhaust	194424	194424	194424	194424
6	Burner, Orifice Bracket, Main	98044	98044	98044	98044
7	Burner, Orifice, Main (N) SBN	76243-32	76243-30	76243-33	76243-32
8	Burner Assembly, Main (N) SBN	194648	194648	194648	194648
9	Burner w/Igniter Bracket, Main BTN	194760	194760	194760	194760
11	Gasket, Cleanout	99038	99038	99038	99038
14	Control, Ignition Assembly	194392	194392	194392	194392
17	Cover, Control Box	194395	194395	194395	194395
18	Cover, Inner	194388-4	194388-4	194388-4	194388
19	Cover, Jacket	<u>194389</u>	<u>194389</u>	<u>194389</u>	<u>194389</u>
22	Ignitor, Flame Sensor	194405	194405	194405	194405
23	Insulation, Top	194439	194439	194439	194439
*39	Manual, Instruction-SBN	194403	194403	194403	194403
40	Plate, Mounting	193439	193439	193439	193439
41	Probe/ECO, Upper Thermostat	<u>194396</u>	<u>194396</u>	<u>194396</u>	<u>194396</u>
42	Probe/Lower Thermostat	194397	194397	194397	194397
43	Rod, Anode	180618-42	180618-42	180618-42	180618-42
44	Switch, Blower Prover	194411-3	194411-7	194411-4	194411-3
45	Switch, Low Gas Pressure	191149-5	191149-5	191149-5	191149-5
46	Switch, Off/On	193243	193243	193243	193243
47	Thermostat, Digital	194393	194393	194393	194393
48	Tube, Inlet	192626-1	192626-1	192626-1	192626-1
49	Tube, Outlet	192627-1	192627-1	192627-1	192627-1
51	Valve, Gas - Natural SBN	194536-1	194536-1	194536	194536
	BTI Valve, Gas - Propane	194536-3	194536-3	194536-3	194536-3
52	Valve, T&P	192467	192467	192467	192467
*53	Wire Harness - Control Nat. Gas	194545	194545	194545	194545
*54	Wire Harness - Power	194398	194398	194398	194398

*Items not illustrated.
Part numbers underlined are recommended stock items for emergency replacement (consider gas used in your area only).
Request from Parts Department by giving all information such as model and series number, type of gas and specifications.

SBN TANK TYPE COMMERCIAL GAS WATER HEATER SERVICE HANDBOOK

Item	250(A)	275(A)	310(A)	366(A)	400(A)
Blower Assembly:					
3	Blower	194408	194408	194408	194408
4	Outlet Assembly, Exhaust	194424	194424	194424	194424
6	Burner, Orifice Bracket, Main	98044	98044	98044	98044
7	Burner Orifice, Main (N) SBN	76243-30	76243-33	76243-31	76243-30
8	Burner Assembly, Main SBN	194648	194648	194648	194648
9	Burner w/Igniter Bracket, Main SBN ..	194383	194383	194383	194383
11	Gasket, Cleanout	99038	99038	99038	99038
14	Control, Ignition Assembly	194392	194392	194392	194392
17	Cover, Control Box	194395	194395	194395	194395
18	Cover, Inner SBN	194388-4	194388-4	194388-4	194388
19	Cover, Jacket	194389	194389	194389	194389
*22	Igniter, Flame Sensor	<u>194405</u>	<u>194405</u>	<u>194405</u>	<u>194405</u>
23	Insulation, Top	194439	194439	194439	194439
*39	Manual, Instruction SBN	194403	194403	194403	194403
40	Plate, Mounting	193243	193243	193243	193243
41	Probe/ECO, Upper Thermostat	194396	194396	194396	194396
42	Probe/Lower Thermostat	<u>194397</u>	<u>194397</u>	<u>194397</u>	<u>194397</u>
43	Rod, Anode	180618-42	180618-42	180618-42	180618-42
44	Switch, Blower Prover SBN	<u>194411-3</u>	<u>194411-8</u>	<u>194411-2</u>	<u>194411</u>
45	Switch, Low Gas Pressure	191149-5	191149-5	191149-5	191149-5
46	Switch, Off/On	193243	193243	193243	193243
47	Thermostat, Digital	194393	194393	194393	194393
48	Tube, Inlet	192626-1	192626-1	192626-1	192626-1
51	Valve Gas - Natural SBN	<u>194536-1</u>	<u>194536-1</u>	<u>194536</u>	<u>194536</u>
52	Valve, T&P	192467	192467	192467	192467
*53	Wire Harness - Control Natural	194545	194545	194545	194545
	Wire Harness - Control Propane	194399	194399	194399	194399
*54	Wire Harness - Power	194398	194398	194398	194398

*Items not illustrated.
Part numbers underlined are recommended stock items for emergency replacement.
Request from Parts Department by giving all information such as model and series number, type of gas and specifications.

Model	Orifice Drill Size
120	37
154	42
180	37
250	32
275	38
310	36
366	32
390	31

SBN TANK TYPE COMMERCIAL GAS WATER HEATER SERVICE HANDBOOK

GENERAL QUESTIONS AND ANSWERS

Q: What is the effect of the draft inducer?

A: The draft inducer has several effects:

- minimizes the excess air through the heater—this often reduces the required vent size
- reduces draft through the heater when it is off
- replaces the draft hood of comparable products
- does not pressurize the vent—common “B” vent materials and the familiar fuel gas codes for venting Category I, fan-assisted, products still apply. Do not combine vent with products that do create a positive pressure vent (Category III or IV).

SBN Induced Draft Model	Vent	BTR Atmospheric Models	Vent Dia. (inches)
120	5	120	5
154-390	6	154-275	6
		305-390	8

Q: What is the significance of low NOx (nitrogen oxide)? (SBN Models)

A: Currently, only Southern California and Texas have adopted rules to reduce the NOx emissions under Rules 1121 and 1146.2, but more of California and Texas are expected to implement this requirement in 2001. Ground-level ozone from man-made pollution is a major ingredient in smog. NOx is a contributor to this ground-level ozone formation. The boilers and water heaters affected by Rule 1121 and 1146.2 release about 14 tons of NOx emissions into the air each day. By comparison, approximately the same quantity of NOx is emitted by 288,000 typical passenger vehicles daily. It is estimated that a full implementation of this emissions rule will reduce NOx by about 11 tons daily. These emission requirements are expected to be implemented by other cities and states soon. The rules apply to natural gas water heaters and boilers.

SBN TANK TYPE COMMERCIAL GAS WATER HEATER SERVICE HANDBOOK

Q: When should anode rods, which provide additional protection against corrosion, be replaced?

A: Anode rods should be replaced when large gouges or pits appear in the anodes. It is recommended that anodes be inspected every six months.

Q: Does the inducer motor require oiling?

A: No.

Q: What size breaker should be used?

A: The heater should draw less than 5 amps and there is a 3-amp car-type fuse on the control board. This fuse protects the boards.

SBN TANK TYPE COMMERCIAL GAS WATER HEATER SERVICE HANDBOOK

Electrical Information			
Part Name	Number	Voltage	Amperes
Integrated Water Heater Control (Temperature Control Board)	194393-0	XFMER Secondary 24 V	1.5
		Field Output 24 V	11.5
Inducer (Blower)	194408-0	120 VAC	1.7
ECO (Part of Upper Temperature Sensor)	194396	24 V - Opens at 203° ± 5.4°F Closes ± 193° F	0.3
Main Gas Valve		24 VAC	1.5
Inducer (Blower)	194408	120 VAC	2.2 FLA
			3.5 LRA
Igniter	194405	120 VAC	2
OPT Power Venter		120 VAC	14.5 FLA
			26.0 LRA

Draft Proving (Pressure) Switch Table		
SBN Models	Part No.	Pressure Setting To Close Switch (Inches W.C.)
366	194411-0	(-) 1.60" ± .10"
275	194411-1	(-) 2.00" ± .10"
310	194411-2	(-) 1.75" ± .10"
120, 200, 250, 390	194411-3	(-) 2.40" ± .10"
154, 180, 199	194411-4	(-) 2.60" ± .10"
-	194411-5	(-) 2.50" ± .10"

For Additional Information
Contact
State Water Heater Technical Information
At
1-800-365-0577

Prepared By The Training Department
In Ashland City, Tennessee

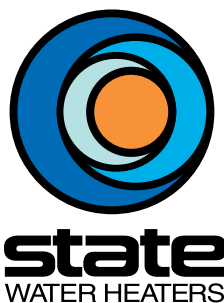

Website: www.statewaterheaters.com

Free Manuals Download Website

<http://myh66.com>

<http://usermanuals.us>

<http://www.somanuals.com>

<http://www.4manuals.cc>

<http://www.manual-lib.com>

<http://www.404manual.com>

<http://www.luxmanual.com>

<http://aubethermostatmanual.com>

Golf course search by state

<http://golfingnear.com>

Email search by domain

<http://emailbydomain.com>

Auto manuals search

<http://auto.somanuals.com>

TV manuals search

<http://tv.somanuals.com>