



SERVICE HANDBOOK

HIGH EFFICIENCY COMMERCIAL GAS SERIES

FOR MODELS:

- **SUF 60 120**
- **SUF 100 150**
- **SUF 100 199**
- **SUF 100 250**
- **SUF 130 300**
- **SUF 130 400**

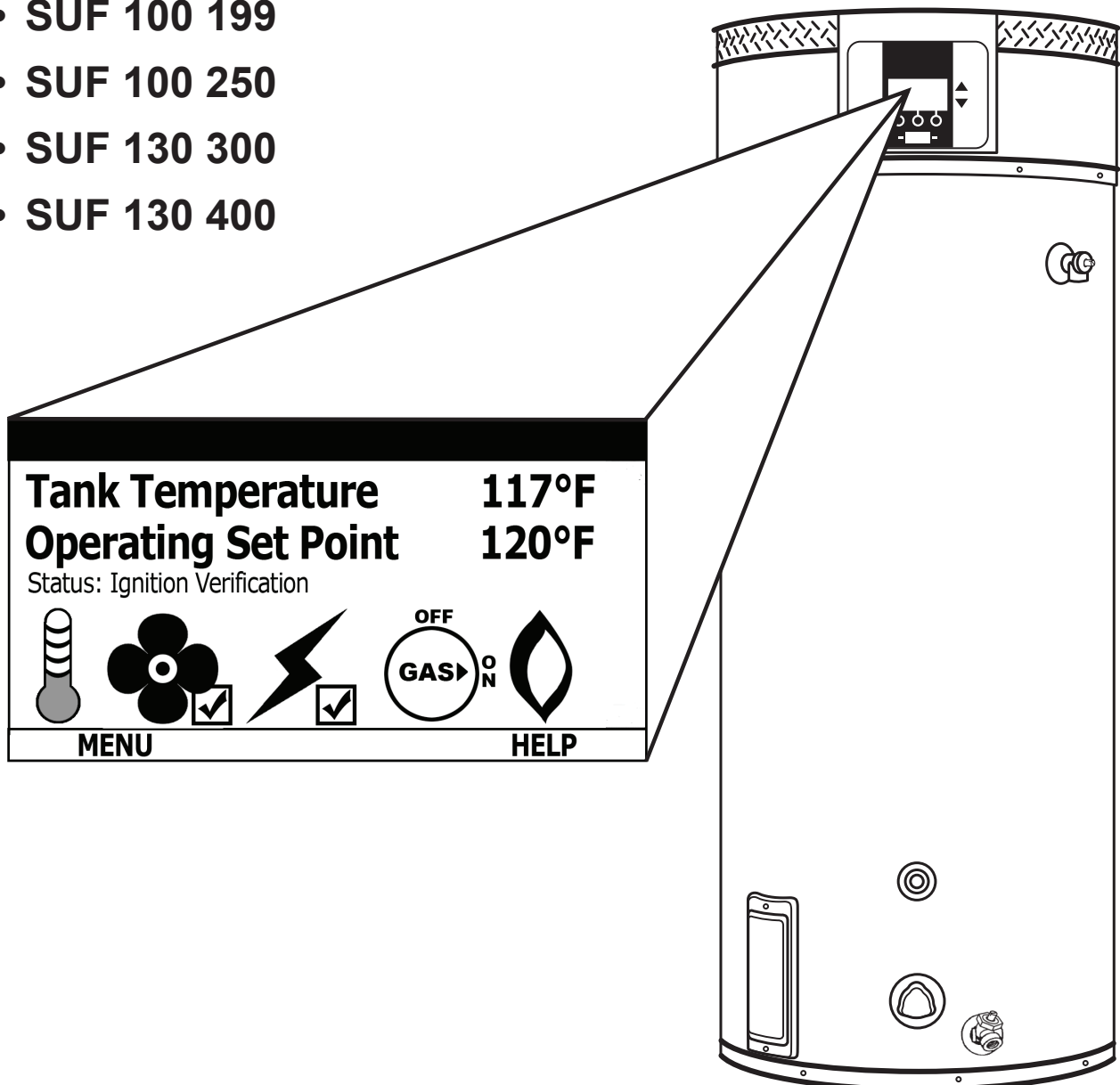

ULTRAFORCE COMMERCIAL GAS WATER HEATER SUF 120 thru 400 SERVICE HANDBOOK

TABLE OF CONTENTS

<p>INTRODUCTION.....2</p> <p>QUALIFICATIONS.....2</p> <p> TOOLS REQUIRED.....3</p> <p>GENERAL INFORMATION.....4</p> <p>GAS PRESSURE SPECIFICATIONS4</p> <p>INSTALLATION QUICK TIPS – SUF 120 and 150 GAS PRESSURE5</p> <p>ADJUSTMENT PROCEDURE:5</p> <p> GAS PRESSURE5</p> <p> SUF 120 AND 150 MODELS.....5</p> <p>HIGH ALTITUDE INSTALLATIONS5</p> <p> SUF 120 - 1505</p> <p>INSTALLATION QUICK TIPS - SUF 199 AND 250 GAS PRESSURE6</p> <p>ADJUSTMENT PROCEDURE:.....6</p> <p> GAS PRESSURE6</p> <p> SUF 199 AND 250 MODELS6</p> <p>HIGH ALTITUDE INSTALLATION.....6</p> <p>INSTALLATION QUICK TIPS - SUF 300, 400 GAS PRESSURE.....7</p> <p>ADJUSTMENT PROCEDURE:.....7</p> <p> GAS PRESSURE.....7</p> <p> SUF 300,400,.....7</p> <p> HIGH ALTITUDE ADJUSTMENT7</p> <p> SUF 300,400,.....7</p> <p>INSTALLATION TIPS - SUF 300, 4008</p> <p>VENTING TABLES SUF 120 – 250.....9</p> <p>VENTING TABLES SUF 300,400,.....9</p> <p>VENTING - ALL MODELS – SINGLE PIPE POWER VENT – USING ROOM AIR.....10</p> <p>VENTING – ALL MODELS – TWO PIPE DIRECT VENT – USING OUTSIDE AIR.....11</p> <p>VENT TERMINATION – DIRECT VENT – ALL MODELS .12</p> <p>DIRECT VENTING – ALL MODELS.....13</p> <p>CONTROL OVERVIEW14</p> <p>CONTROL OVERVIEW – ALL MODELS.....14</p> <p>ADJUSTING TANK TEMPERATURE – OPERATING SET POINT - DIFFERENTIAL.....15</p> <p>CHANGING THE DISPLAY UNITS.....16</p> <p>FAULT AND WARNING CONDITIONS – ADVANCED DIAGNOSTIC INFORMATION.....17</p> <p>ACCESS TO THE CURRENT FAULT OR WARNING.....18</p> <p>VIEWING THE FAULT HISTORY - VIEWING INFORMATION ABOUT THE HEATER.....19</p> <p> CONTROL SEQUENCE (TYPICAL ALL MODELS).....20</p> <p> CONTROL SEQUENCE FLOW CHART.....21</p> <p> CONTROLS – CENTRAL CONTROL BOARD – CCB22</p> <p> CONTROLS – GAS VALVE SUF 120.....23</p> <p> CONTROLS – GAS VALVE SUF 150.....23</p> <p> CONTROLS – GAS VALVE SUF 199 and 250.....24</p> <p>ADJUSTMENT PROCEDURE:.....24</p> <p> GAS PRESSURE24</p> <p> SUF 199 AND 250 MODELS24</p> <p> CONTROLS – GAS VALVE SUF 199 and 250.....25</p>	<p> CONTROLS – GAS VALVE , ORIFICE CHART– SUF300,400,.....26</p> <p> CONTROLS – PRESSURE SWITCHES – ALL MODELS..27</p> <p> CONTROLS – PRESSURE SWITCHES – SUF 120 through 250.....28</p> <p> CONTROLS – PRESSURE SWITCHES – SUF 300,400,..29</p> <p> CONTROLS – CONNECTIONS, IGNITER, FLAME SENSOR, SIGHT GLASS, POWERED ANODES.....30</p> <p> HOT SURFACE IGNITER / FLAME SENSOR / CONTROL TIMING.....31</p> <p> BLOWER SPEED CONTROL SUF 199 AND 250.....32</p> <p> VARIABLE FREQUENCY DRIVE – SUF 400.....33</p> <p> VARIABLE FREQUENCY DRIVE - BLOWER SPEED AND PRESSURE READINGS.....34</p> <p> WIRING DIAGRAM – SUF 120 – 30035</p> <p> WIRING DIAGRAM – SUF 400,.....36</p>
---	---

ULTRAFORCE COMMERCIAL GAS WATER HEATER SUF 120 thru 400 SERVICE HANDBOOK

INTRODUCTION

The service handbook is designed to aid in servicing and troubleshooting State Water Heaters Ultra Force SUF commercial water heaters in the field. No duplication or reproduction of this book may be made without the express written authorization of State Water Heaters.

The following text and illustrations will provide you with a step by step procedure to verify proper installation, operation, and troubleshooting procedures. Additional quick reference data is included to assist you in servicing these products.

The information contained in this handbook is designed to answer commonly faced situations encountered in the operation of this product line and is not meant to be all

inclusive. If you are experiencing a problem not covered in this handbook, please contact State Water Heaters Technical Information at 1-800-365-0024, by e mail at help@statewaterheaters.com or your local State Water Heater representative for further assistance.

Our website: www.statewaterheaters.com

is also a resource for installation and service information. This handbook is intended for use by licensed plumbing professionals and reference should be made to the installation manual accompanying the product. This handbook contains supplemental information to the product's installation and operation manual.

QUALIFICATIONS

ANSI Z223.1 Sec 3.3.83

"Qualified Agency"

"Any individual, firm, corporation or company that either in person or through a representative is engaged in and is responsible for (a) the installation, testing or replacement of gas piping or (b) the connection, installation, testing, repair or servicing of appliances and equipment; that is experienced in such work; that is familiar with all precautions required; and that has complied with all the requirements of the authority having jurisdiction."

Service of this water heater requires ability equivalent to that of a Qualified Service Agent (Licensed tradesman) in the field involved. Installation skills such as plumbing, air supply, venting, gas supply, electrical supply are required in addition to electrical testing skills. Some products may require combustion testing equipment and certification. If you do not possess these skills or do not have the proper tools you should not attempt to service this water heater.

ULTRAFORCE COMMERCIAL GAS WATER HEATER SUF 120 thru 400 SERVICE HANDBOOK

TOOLS REQUIRED

- ELECTRICAL MULTIMETER CAPABLE OF MEASURING CONTINUITY/ OHMS, AC & DC VOLTS, AMPERES, MICROAMPERES, MILLIVOLTS, and FREQUENCY(Hz)
 - UeI Model DL289 or equivalent
- DIGITAL MANOMETER ± 60 " W. C. in .01" increments
 - Note: A digital manometer is required for testing pressure switches and can replace a gas pressure gauge, draft gauge or slack tube manometer for checking gas pressure.
 - UeI model EM200 or equivalent
- WATER PRESSURE GAUGE w/ LAZY HAND AND HOSE BIBB CONNECTION
- THERMOMETER
- 1-1/16 INCH SOCKET WITH EXTENSION FOR ANODE REPLACEMENT
- SET OF NUMBERED DRILL BITS



ULTRAFORCE COMMERCIAL GAS WATER HEATER SUF 120 thru 400 SERVICE HANDBOOK

GENERAL INFORMATION

INSTALLATION REQUIREMENTS FOR THE COMMONWEALTH OF MASSACHUSETTS

For all side wall terminated, horizontally vented power vent, direct vent, and power direct vent gas fueled water heaters installed in every dwelling, building or structure used in whole or in part for residential purposes, including those owned or operated by the Commonwealth and where the side wall exhaust vent termination is less than seven (7) feet above finished grade in the area of the venting, including but not limited to decks and porches, the following requirements shall be satisfied:

INSTALLATION OF CARBON MONOXIDE DETECTORS

At the time of installation of the side wall horizontal vented gas fueled equipment, the installing plumber or gas fitter shall observe that a hard wired carbon monoxide detector with an alarm and battery back-up is installed on the floor level where the gas equipment is to be installed. In addition, the installing plumber or gas fitter shall observe that a battery operated or hard wired carbon monoxide detector with an alarm is installed on each additional level of the dwelling, building or structure served by the sidewall horizontal vented gas fueled equipment. It shall be the responsibility of the property owner to secure the services of qualified licensed professionals for the installation of hard wired carbon monoxide detectors. In the event that the side wall horizontally vented gas fueled

equipment is installed in a crawl space or an attic, the hard wired carbon monoxide detector with alarm and battery back-up may be installed on the next adjacent floor level. In the event that the requirements of this subdivision can not be met at the time of completion of installation, the owner shall have a period of thirty (30) days to comply with the above requirements provided that during said thirty (30) day period, a battery operated carbon monoxide detector with an alarm shall be installed.

APPROVED CARBON MONOXIDE DETECTORS
Each carbon monoxide detector as required in accordance with the above provisions shall comply with NFPA 720 and be ANSI/UL 2034 listed and CSA certified.

SIGNAGE

A metal or plastic identification plate shall be permanently mounted to the exterior of the building at a minimum height of eight (8) feet above grade directly in line with the exhaust vent terminal for the horizontally vented gas fueled heating appliance or equipment. The sign shall read, in print size no less than one-half (1/2") inch in size,

“GAS VENT DIRECTLY BELOW. KEEP CLEAR OF ALL OBSTRUCTIONS.”

GAS PRESSURE SPECIFICATIONS

MODELS	Natural 120-150	Propane 120-150	Natural 199-250	Propane 199-250	Natural 300/400/500	Propane 300/400/500
Maximum Gas Supply Pressure	10.5" WC (2.59kPa)	14.0"WC (3.45kPa)	10.5"WC (2.59kPa)	14.0"WC (3.45kPa)	11.0"WC (2.74kPa)	14.00"WC (3.49kPa)
Nominal Gas Supply Pressure	7.0"WC (1.74kPa)	11.0"WC (2.74kPa)	7.0"WC (1.74kPa)	11.0"WC (2.74kPa)	7.0"WC (1.74kPa)	11.0"WC (2.74kPa)
Minimum Gas Supply Pressure (Low Gas Press. Switch Setting)	4.8"WC (1.20kPa)	8.5"WC (2.12kPa)	4.8"WC (1.20kPa)	8.5"WC (2.12kPa)	5.2"WC (1.54kPa)	11.0"WC (2.74kPa)
Manifold Pressure	4.0"WC (0.98kPa)	10.0"WC (2.49 kPa)	0"WC (0 kPa)	0"WC (0 kPa)	4.00"WC (1.25kPa)	10.0"WC (2.49kPa)

ULTRAFORCE COMMERCIAL GAS WATER HEATER SUF 120 thru 400 SERVICE HANDBOOK

INSTALLATION QUICK TIPS – SUF 120 and 150 GAS PRESSURE

ADJUSTMENT PROCEDURE: GAS PRESSURE SUF120 AND 150 MODELS

Main line gas pressure to the water heater for natural gas should be between a **maximum** of 10.5"W.C. (2.59kPa) for natural gas, 14.0"W.C.(3.45kPa) for propane and a **minimum** of 4.8W.C.(1.18kPa) for Natural Gas, and 8.5"W.C. (2.08kPa) for Propane Gas.

A supply gas pressure regulator (service regulator) must be installed on the gas supply line within 10' (305 cm) of the unit.

Also see gas pressure specification table on page 4.

1. Check gas line pressure with a manometer.
2. Check manifold pressure gauge (manometer) connected to the manifold pressure tap on the gas control valve,
If full rate adjustment is required, remove cover screw from top of the gas control valve. Using a small screwdriver, turn adjusting screw clockwise to increase or counterclockwise to decrease gas pressure to obtain 4.0" W.C.(1 K pa) for natural gas and 10.0" W.C. (2.5 kPa) for L.P. Gas.
3. Cycle the burner on and off several times to check its operation.
4. Check the operation of the limit and operating controls.
5. Check the vent system seams and joints and ensure that there is no discharge of flue products into the room.
6. Check the input rate.

HIGH ALTITUDE INSTALLATIONS SUF 120 - 150

For appliance installation locations with elevations above **6,500** feet (1982 meters) consult the "High Altitude Installation" section of the owners manual.

a. Attach a pressure gauge (manometer) to the manifold pressure tap and refer to page 4 for correct pressure.

b. Use this formula to "**clock**" the meter. Be sure other gas consuming appliances are not operating during this interval.

$$\text{Btuh} = 3600 \times \text{H} / \text{T}$$

T = Time in seconds to burn 1 cubic foot of gas.
(With a stopwatch read the gas meter and measure the amount of time required for the heater to consume 1 cubic foot of gas.)

H = Heating value of gas (in Btu's per cubic foot of gas).

Btuh = Actual heater input rate, in Btuh.

EXAMPLE: (Using SUF-150 heater)

T = 25.25 seconds

H = 1050 Btu/ft.³

BTUH = ?

Compare result to the de-rated input required for the elevation at the installation location.

Should it be necessary to adjust the gas pressure to the burner, to obtain the full input rate, the steps below should be followed:

c. Remove the pressure regulator cover screw and adjust the pressure by turning the adjusting screw with a small screwdriver. Do not exceed 4.0" (1 kPa) natural gas models and 10.0" w.c. (2.5kPa) on the propane models. Clockwise to increase gas pressure and input rate. Counterclockwise to decrease gas pressure and input rate.

d. "Clock" the meter as in step (b) above.

e. Repeat steps (c) and (d) until the specified input rate is achieved.

f. Turn the manual gas valve to "OFF". Replace the pressure regulator cover screw. Remove the pressure gauge or manometer from the manifold pressure tap. Replace the set screw in the manifold pressure tap. If the gas pressure regulator cannot be adjusted to give the full input rating with sufficient gas pressure at the valve, check to ensure the unit is equipped with the correct orifice.

**ULTRAFORCE COMMERCIAL GAS WATER HEATER
SUF 120 thru 400 SERVICE HANDBOOK**

INSTALLATION QUICK TIPS - SUF 199 AND 250 GAS PRESSURE

**ADJUSTMENT PROCEDURE:
GAS PRESSURE
SUF 199 AND 250 MODELS**

IMPORTANT NOTE

THE SUF 199 AND 250 MODELS INCORPORATE A NEW GAS CONTROL, WHICH OPERATES AT A MANIFOLD PRESSURE OF 0"W.C. (0 kPa) FOR BOTH NATURAL AND PROPANE GAS. SEE THE GAS PRESSURE CHART ON PAGE 4. THESE MODELS ARE CONFIGURED PRIOR TO BEING SHIPPED FROM THE FACTORY AND NO ADJUSTMENTS ARE NECESSARY PRIOR TO STARTUP. THE CONTROLLER MONITORS THE AIR FLOW AND MAKES ADJUSTMENTS TO THE FAN SPEED WHICH IN EFFECT CONTROLS THE AMOUNT OF GAS FLOW. THEREFORE, THE UNIT WILL SELF ADJUST TO ACQUIRE THE CORRECT AMOUNT OF INPUT.

"Supply gas pressure to the water heater must not exceed a maximum of 10.5" w.c. (295kPa) for natural gas, or 14" w.c. (3.45 kPa) for propane. The minimum supply gas pressure is 4.8" w.c. (1.20 kPa) for natural gas and 8.5" w.c. (2.12 kPa) for propane gas."

Once the unit is installed and filled with water and the inlet pressures confirmed, simply turn the switch "on" and observe operation. Cycle the unit "off" and "on" several times to ensure proper operation.

HIGH ALTITUDE INSTALLATION

The SUF 199 and 250 models are suitable for installation up to 10,100 feet above sea level with no adjustments.

GAS ORIFICE

The SUF 199 and 250 models do not have a natural gas orifice. A .230" orifice is used on LP gas models.

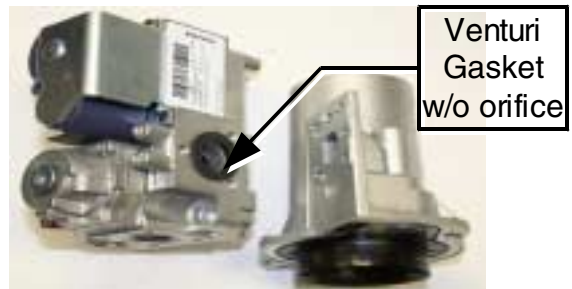

Gas Control Without Orifice

Natural Gas



Gas Control with .230" LP Orifice

A supply gas pressure regulator (service regulator) must be installed on the gas supply line within 10' (305 cm) of the unit.

ULTRAFORCE COMMERCIAL GAS WATER HEATER SUF 120 thru 400 SERVICE HANDBOOK

INSTALLATION QUICK TIPS - SUF 300, 400 GAS PRESSURE

ADJUSTMENT PROCEDURE: GAS PRESSURE SUF 300,400,

HIGH ALTITUDE ADJUSTMENT SUF 300,400,

For high altitude adjustments, contact the help line on the front of the water heater or contact help@statewaterheaters.com .

A minimum dynamic gas supply pressure of 5.2" w.c. (1.29 kPa) for Natural Gas and 11" w.c. (2.74 kPa) for LP Gas is required before making any adjustment to the gas control pressure regulator. Attempts to adjust the regulator during periods of low gas supply pressure could result in over firing of the water heater when the gas supply pressure returns to normal.

1. Check gas line pressure with a manometer, adjust the gas supply line pressure Gas Pressure table on page 4.
2. Check manifold pressure using a pressure gauge (manometer) connected to the manifold pressure tap on the gas control valve, If full rate adjustment is required, remove cover screw from top of the gas control valve. Using a small screwdriver, turn adjusting screw clockwise to increase or counter clockwise to decrease gas pressure to obtain 4.0" w.c. (0.996 kPa) for Natural Gas and 10" w.c. (2.49kPa) for LP gas.
3. Cycle the burner on and off several times to check its operation.
4. Check the operation of the limit and operating controls.
5. Check the vent system seams and joints and ensure that there is no discharge of flue products into the room.
6. Check the input rate as shown on page 5.

ULTRAFORCE COMMERCIAL GAS WATER HEATER SUF 120 thru 400 SERVICE HANDBOOK

INSTALLATION TIPS - SUF 300, 400

"AT A GLANCE" QUICK INSTALLATION TIPS

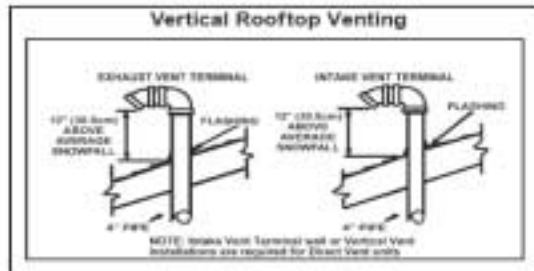
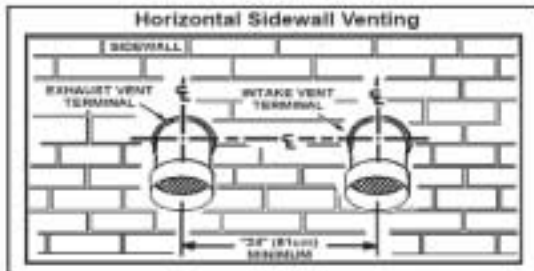
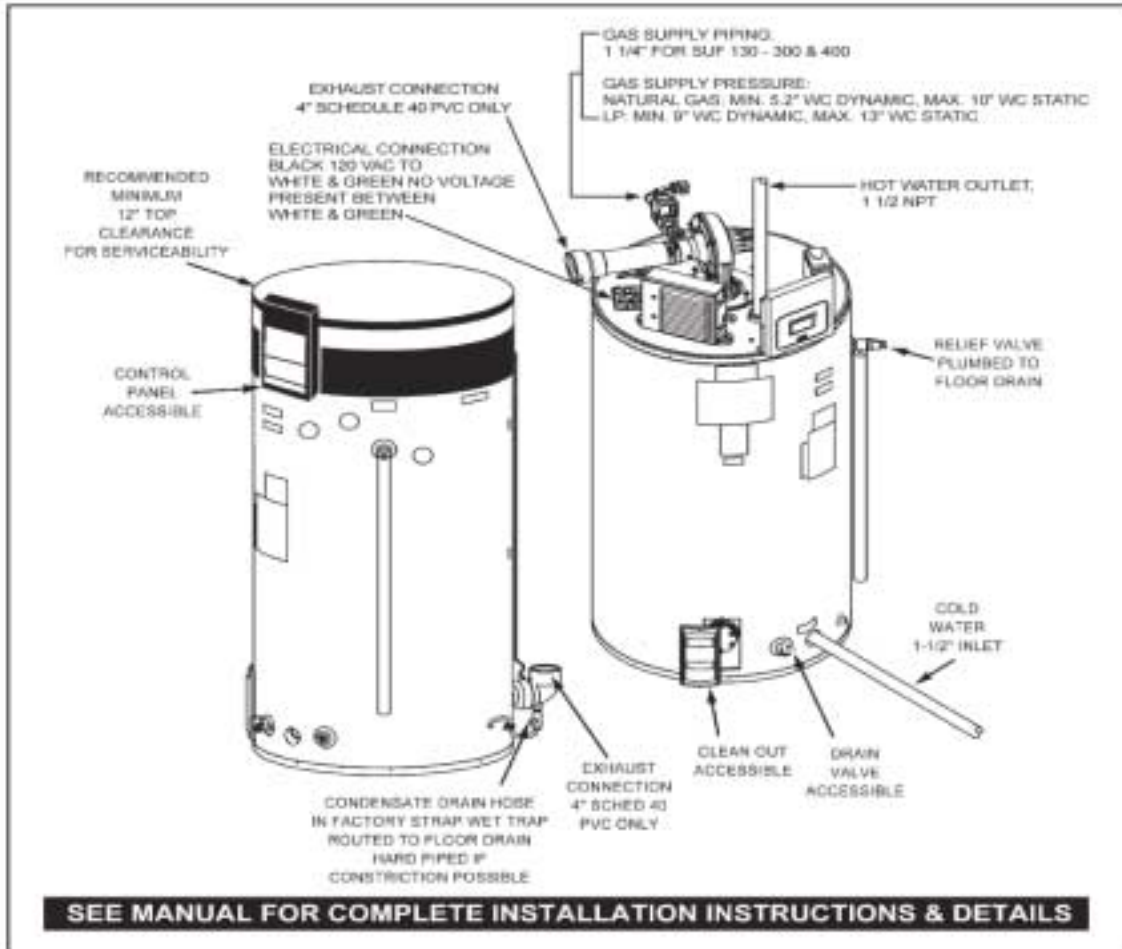

**ULTRAFORCE COMMERCIAL GAS WATER HEATER
SUF 120 thru 400 SERVICE HANDBOOK**

VENTING TABLES SUF 120 – 250

Maximum equivalent feet of intake and vent pipe using 3" PVC is 50 feet (15.2m). Equivalent feet must include any 90° elbows (two 45° elbows equal one 90° elbow). Three inch diameter 90° elbows are equivalent to 5' (1.5m) of pipe.

Maximum equivalent feet of intake and vent pipe using 4" PVC is 120 feet (36.6m). Equivalent feet must include any 90° elbows (two 45° elbows equal one 90° elbow). Four inch diameter 90° elbows are equivalent to 5' (1.5m) of pipe.

Vent Length Table Equivalent Feet (Meters) 120 through 250

Number of 90° Elbows	3" Minimum Pipe (Ft./M.)	3" Maximum Pipe (Ft./M.)	4" Maximum Pipe (Ft./M.)
ONE (1)	7/2.1	45/13.7	115/35
TWO (2)	7/2.1	40/12.2	110/33.5
THREE (3)	7/2.1	35/10.7	105/32
FOUR (4)	7/2.1	30/9.1	100/30.5
FIVE (5)	7/2.1	---	95/29
SIX (6)	7/2.1	---	90/27.4

VENTING TABLES SUF 300,400,

Vent Length Table Equivalent Feet (Meters) 300,400,

Number of 90° Elbows	4" PVC Maximum Feet / meters of Pipe
ONE (1)	65' / 19.7 m
TWO (2)	60' / 18.2 m
THREE (3)	55' / 16.7 m
FOUR (4)	50' / 15.2 m
FIVE (5)	45' / 13.6 m
SIX (6)	40' / 12.1 m

ULTRAFORCE COMMERCIAL GAS WATER HEATER SUF 120 thru 400 SERVICE HANDBOOK

VENTING - ALL MODELS – SINGLE PIPE POWER VENT – USING ROOM AIR

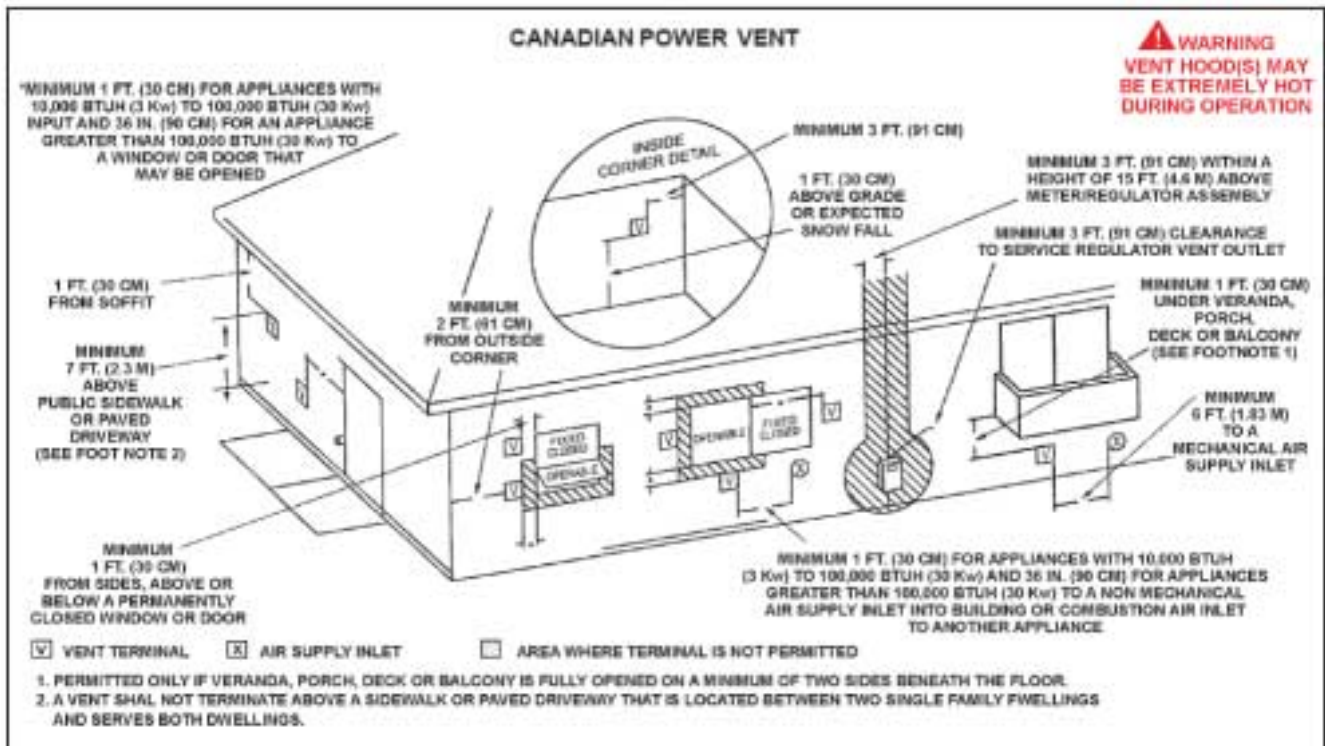
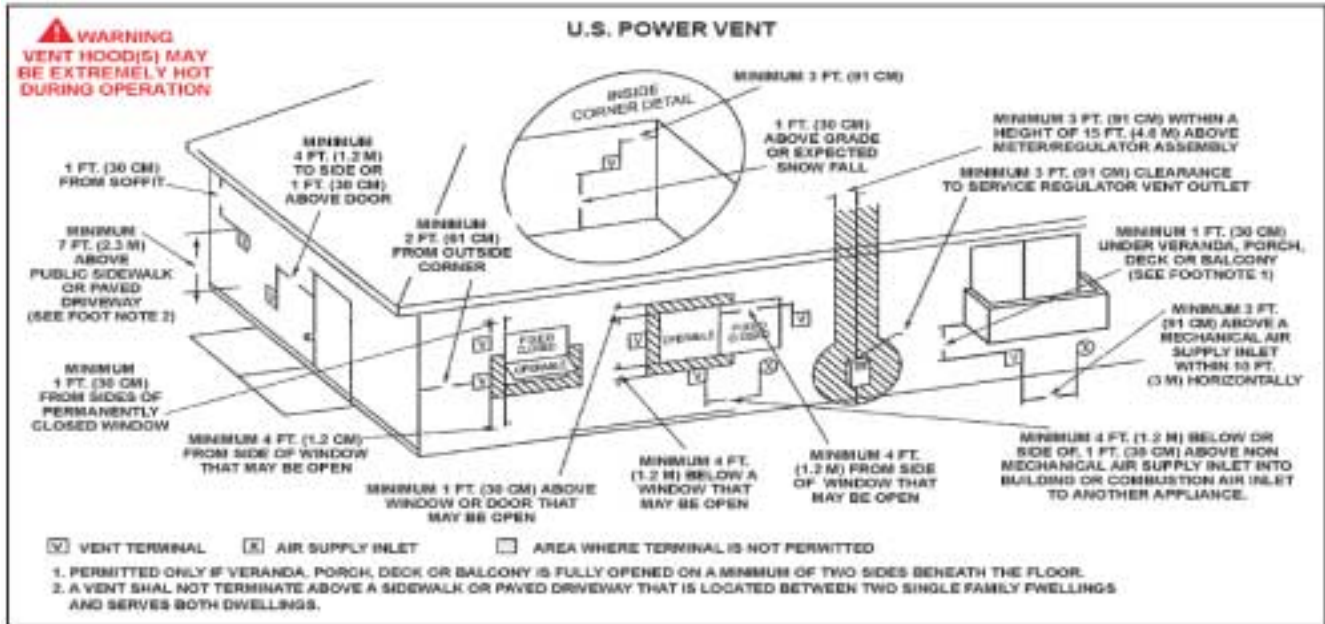

ULTRAFORCE COMMERCIAL GAS WATER HEATER SUF 120 thru 400 SERVICE HANDBOOK

VENTING – ALL MODELS – TWO PIPE DIRECT VENT – USING OUTSIDE AIR

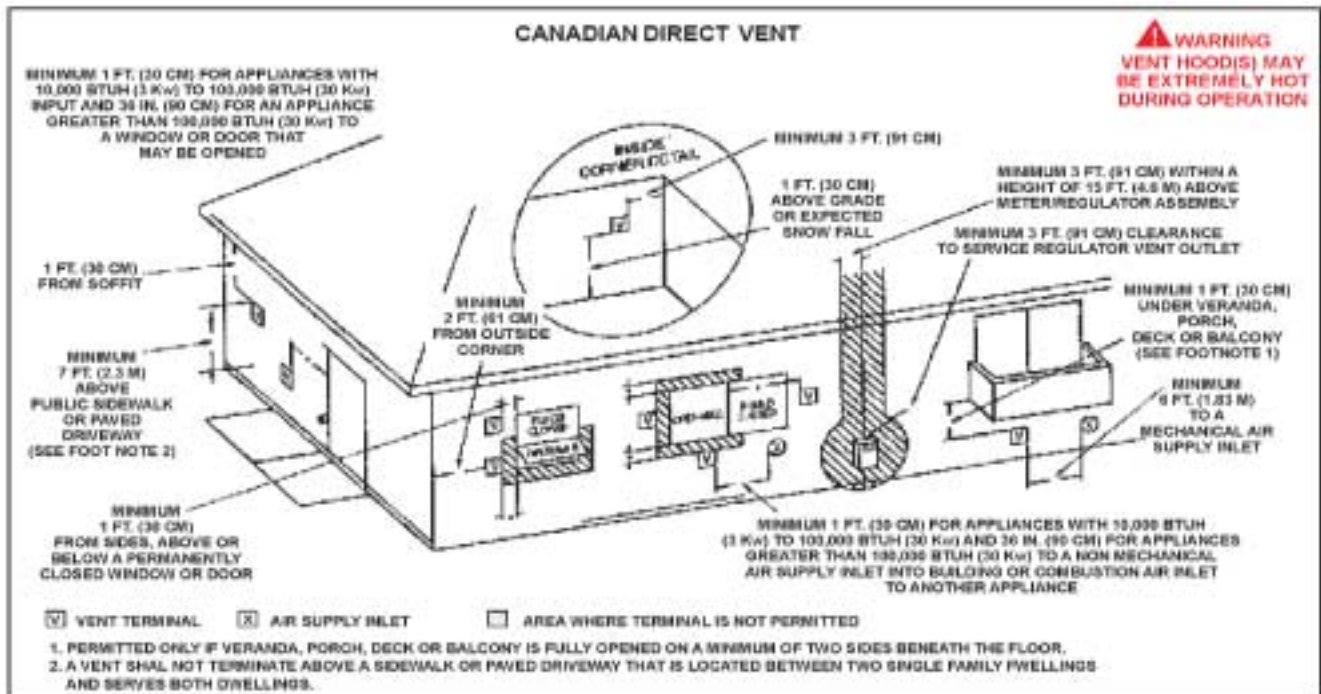
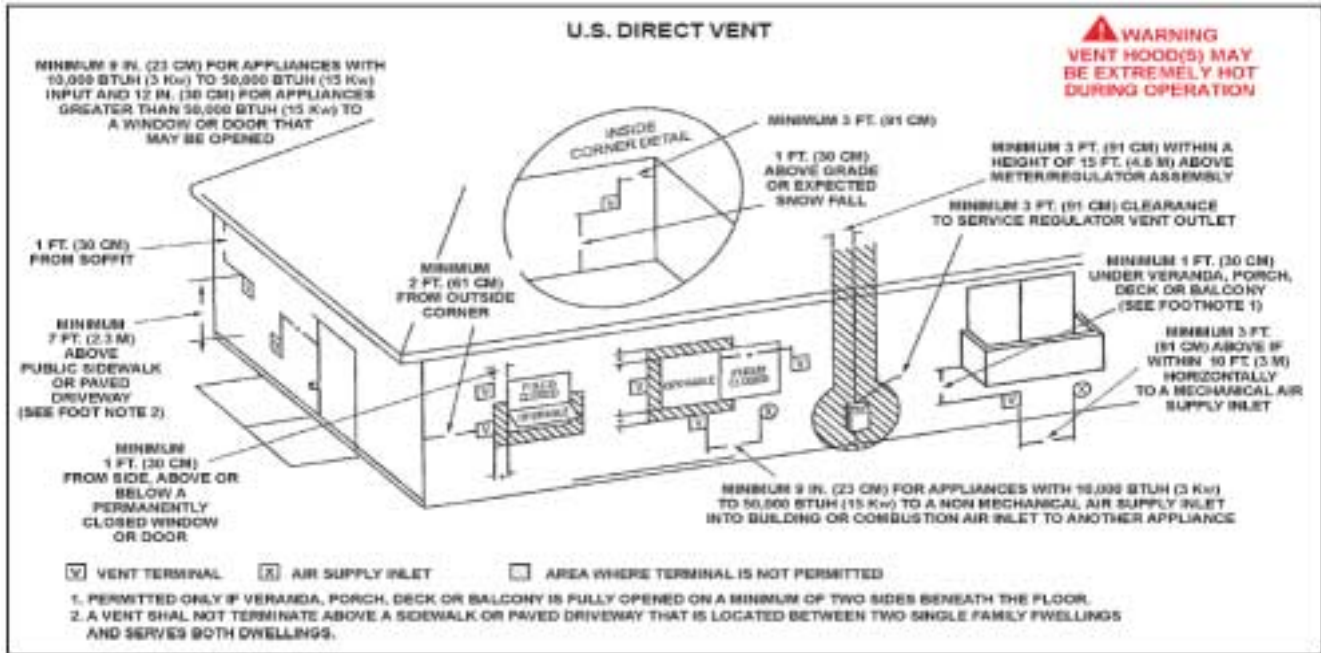

ULTRAFORCE COMMERCIAL GAS WATER HEATER SUF 120 thru 400 SERVICE HANDBOOK

VENT TERMINATION – DIRECT VENT – ALL MODELS

WHEN LOCATING THE TERMINALS ON A SIDEWALL, THE FOLLOWING SPECIFICATIONS PERTAINING TO TERMINAL LOCATION MUST BE FOLLOWED.

1. The intake vent terminal and the exhaust vent terminal must terminate on the same exterior wall and must be located at a minimum of 24" (61cm) from the vertical centerline of the exhaust vent terminal (see Figure 9). In colder climates increasing the 24" (61cm) minimum will reduce possibility of frost over from side winds blowing exhaust vapors to the air intake of the direct vent.
2. The horizontal centerline of the intake vent terminal **may not** be located lower than the horizontal centerline of the exhaust vent terminal

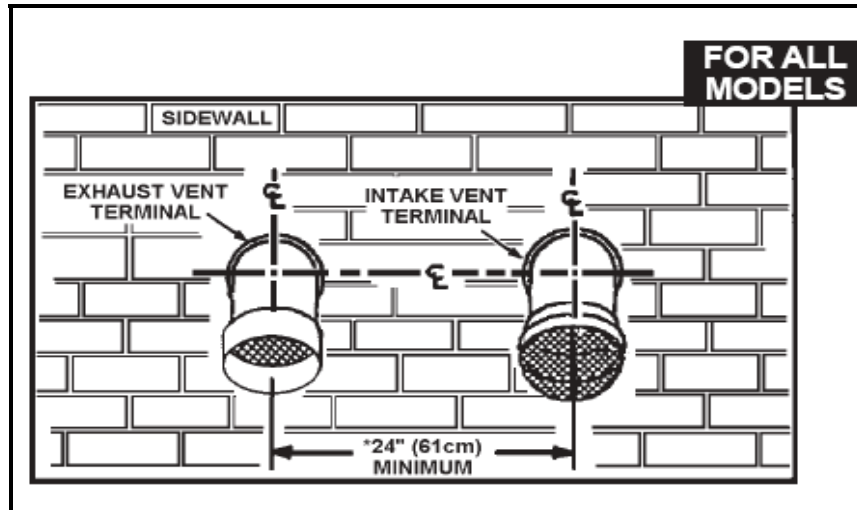

**ULTRAFORCE COMMERCIAL GAS WATER HEATER
SUF 120 thru 400 SERVICE HANDBOOK**

DIRECT VENTING – ALL MODELS

The air intake provided on the unit contains a mesh screen to prevent large particles from entering the unit. **WHEN THE UNIT IS TO BE SET UP AS A DIRECT VENT, THE BALANCE PLATE AND MESH SCREEN MUST BE REMOVED BEFORE GLUING PIPE TO THE CONNECTOR. THE INLET VENT PIPE MAY THEN BE GLUED TO THE AIR INTAKE PROVIDED ON THE UNIT.**

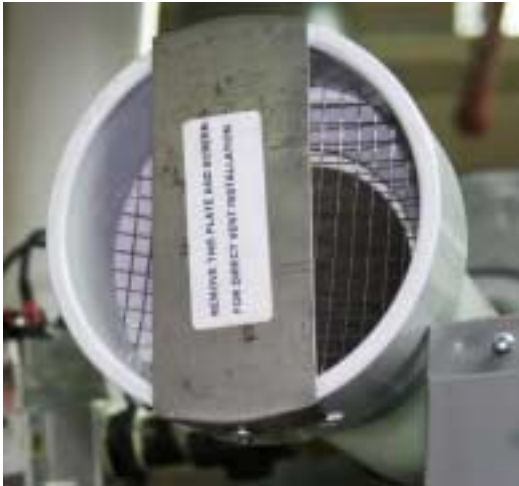

Remove the balance plate and mesh screen before gluing intake air pipe to the fitting.

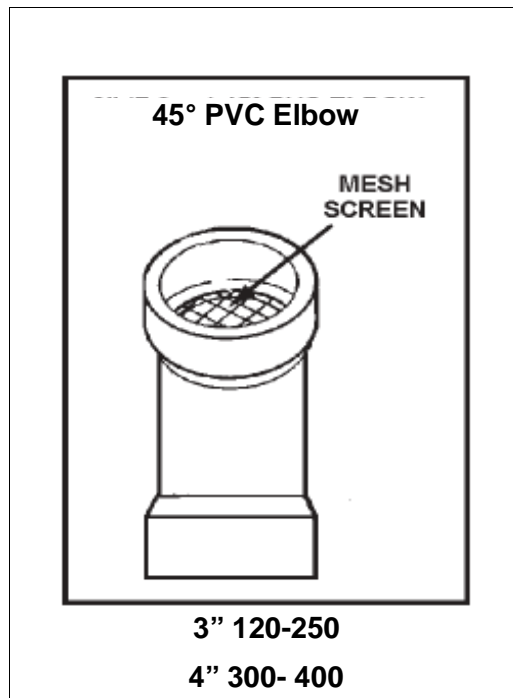

Two 3" or 4" 45° PVC elbows with mesh screens are provided with each unit. Both elbows are to be used in direct vent applications. The screens are provided to keep vermin and large debris from entering the intake air and exhaust vent runs.

ULTRAFORCE COMMERCIAL GAS WATER HEATER SUF 120 thru 400 SERVICE HANDBOOK

CONTROL OVERVIEW

Interaction with the water heater controller is done through an LCD display called the **Universal Interface Module (UIM)**. This screen is also referred to as the “desktop” or “desktop menu”. Up and down buttons and three operation buttons allow navigation through the control menus and to make adjustments to the water heater. Operation of the three lower buttons is defined immediately above them on the screen.

While the water heater is operating, the user interface will display the desktop screen (if there are no active faults or warnings).

- An example of this screen is shown below.
- The first temperature on this screen is the temperature of the water inside the tank.
- The second temperature on this screen is the *Operating Set Point*.
- The *Operating Set Point* is the temperature at which the water heater will maintain the water inside the tank.
- The third line on the screen is a text description of the *Operational State* of the water heater. The operating state of the water heater is also indicated graphically by status icons.

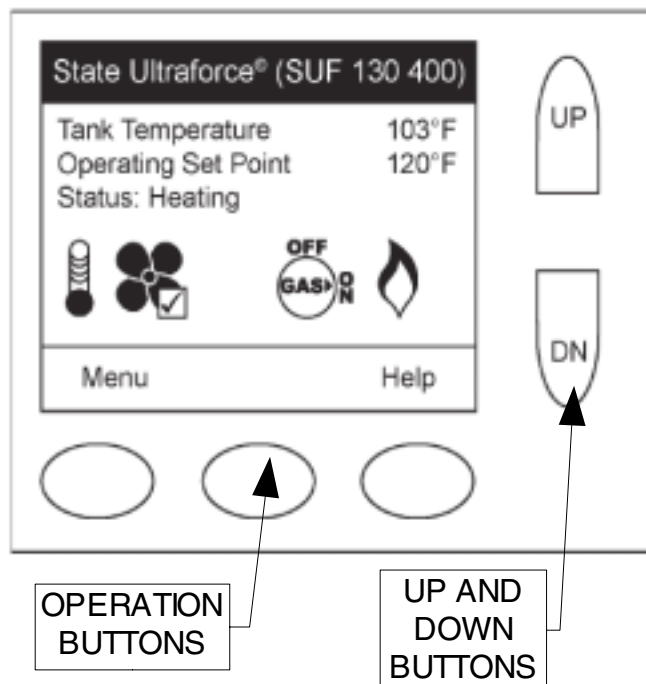

The table of status icons describes graphically operational details of the water heater. Below is a legend of all the status icons:

Status Icon	Description
	The temperature of the water in the tank has fallen and the water heater will now initialize a new heating cycle.
	The temperature of the water in the tank has reached the <i>Operating Set Point</i> .
	The control is unable to initiate any further heating cycles. This is usually caused by a fault condition detected by the control, but can also occur when an external system (like an energy management system) has asked the water heater to discontinue any further heat cycles.
	The blower is being energized.
	The blower pressure switch has been made.
	The igniter has been energized.
	The igniter has been energized and sufficient current for ignition has been detected.
	The control has requested that the gas valve be turned on.
	The control has sensed flame in the burner.
	The control has detected a fault condition. A fault condition will cause the water heater to discontinue operation.
	The control has detected a warning condition. These conditions will not cause the water heater to discontinue further heating cycles, but does merit attention.

ULTRAFORCE COMMERCIAL GAS WATER HEATER SUF 120 thru 400 SERVICE HANDBOOK

ADJUSTING TANK TEMPERATURE – OPERATING SET POINT - DIFFERENTIAL

The *Operating Set Point* of this water heater determines the regulated temperature for the water in the tank. This parameter is adjusted in the desktop Temperature menu. Items in this menu allow you to monitor different temperature readings in the tank along with adjusting the *Operating Set Point* and *Differential*.

ACTION:

From the desktop screen, press **Menu**.

DISPLAY:

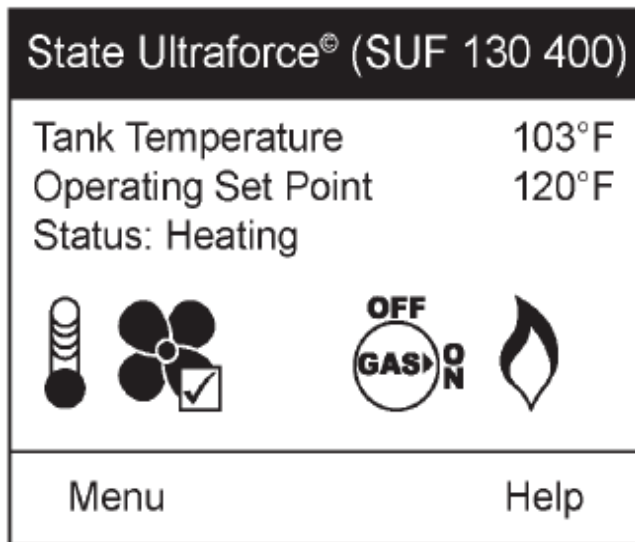

ACTION:

From the Main Menu, press **Select** to enter the "Temperatures" screen.

DISPLAY:

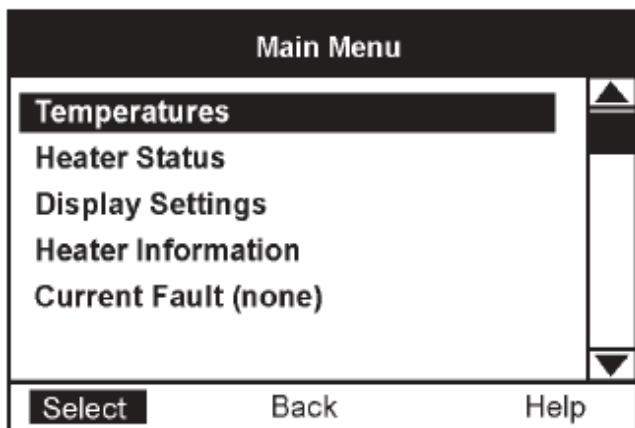

ACTION:

Press **Change** then use the **UP** and **DOWN** buttons to change the temperature Set Point.

DISPLAY:

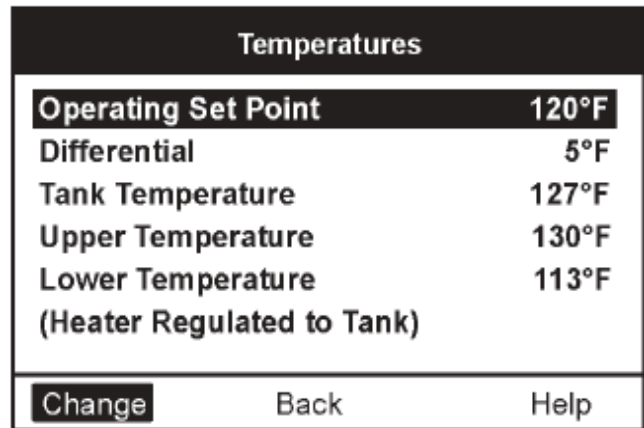

Note: This procedure can also be used to change the *Differential*. The tank Upper and Lower Temperatures are not user changeable. They are determined by the temperature probes on the heater.

ACTION:

Press **Update** to accept the change or **Cancel** to reset it.

DISPLAY:

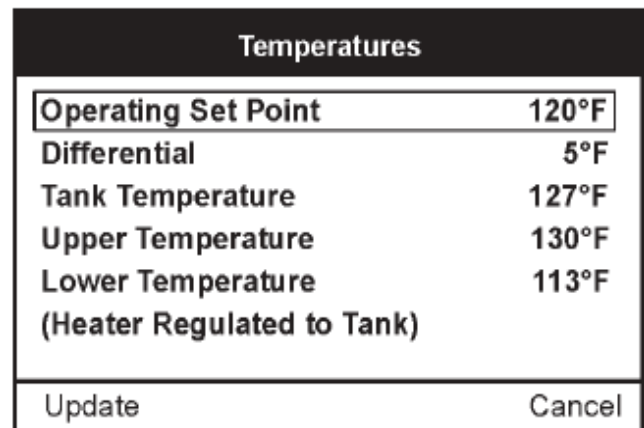

ULTRAFORCE COMMERCIAL GAS WATER HEATER SUF 120 thru 400 SERVICE HANDBOOK

CHANGING THE DISPLAY UNITS

The desktop menu has the option of selecting between degrees Fahrenheit and degrees Celsius for temperature displays. This can be found in the "Display Settings" menu. Also in this menu, you may adjust how the back-light operates and the contrast of the LCD screen.

ACTION:

From the Main Menu, press the **DOWN** button to highlight "Display Settings" then press **Select**.

DISPLAY:

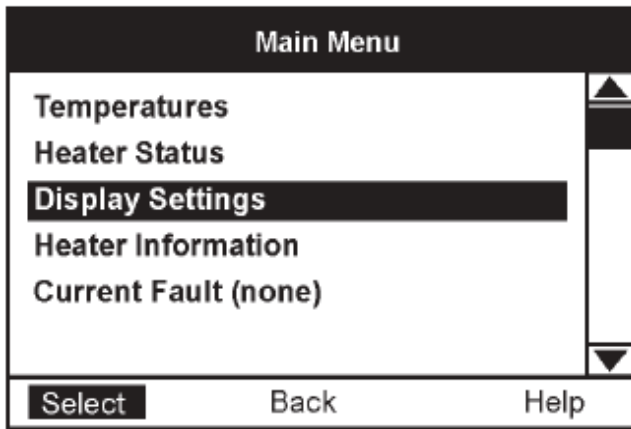

ACTION:

Use the **UP** and **DOWN** buttons to highlight the desired setting. Then press **Change**. Again, use the **UP** and **DOWN** buttons to scroll through the options for that setting.

DISPLAY:

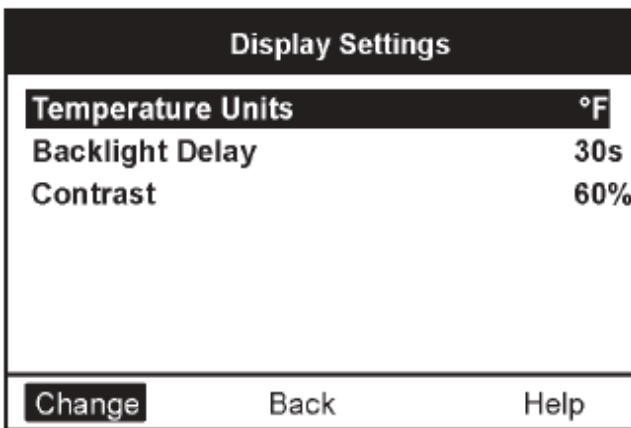

ACTION:

Press **Update** to accept the change or **Cancel** to reject it.

DISPLAY:

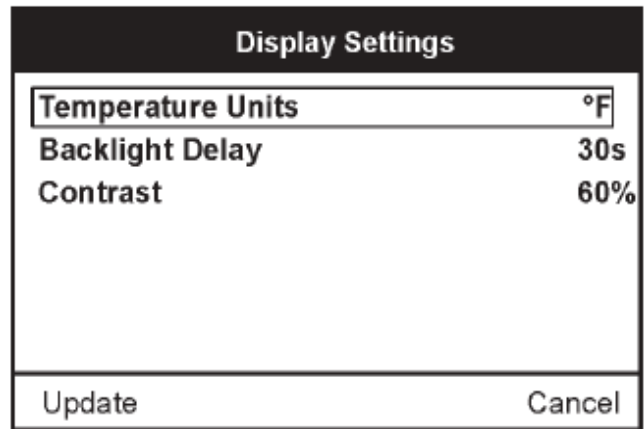

ULTRAFORCE COMMERCIAL GAS WATER HEATER SUF 120 thru 400 SERVICE HANDBOOK

FAULT AND WARNING CONDITIONS – ADVANCED DIAGNOSTIC INFORMATION

This water heater control has the ability to monitor almost all aspects of the water heater's operation. In the case that there is an undesirable or unsafe condition that occurs, the water heater control will detect this condition and determine the appropriate action. The water heater control will display the information on the desktop in plain text that accurately describes the condition and diagnostics information that can be used to correct the issue.

There are two types of conditions that can occur during operation. These are **Warnings and Faults**:

Warnings: This is a non-safety related condition that the control has detected that may cause the water heater to operate in a less than optimal condition, but does not pose a safety concern.

NOTE: When these conditions occur, continued heating cycles will continue and the heater will attempt to regulate the water in the tank to the **Operating Set Point**.

Example of a Warning:

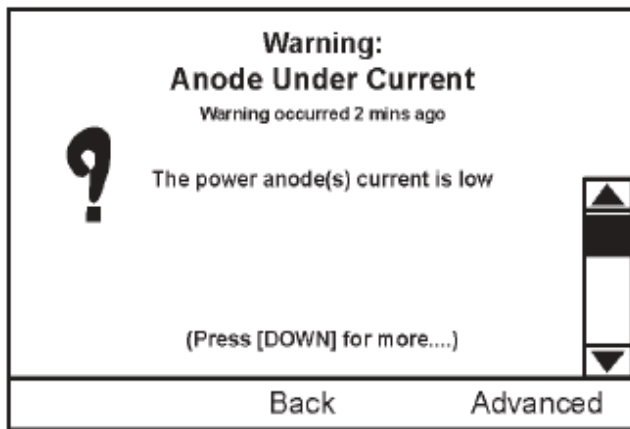

Faults: This is a safety related condition that has been detected by the heater.

NOTE: When these conditions occur, the water heater **WILL NOT CONTINUE** any further heating cycles and the water will no longer be heated until the condition is corrected and, in most cases, power has been cycled.

Example of a Fault:

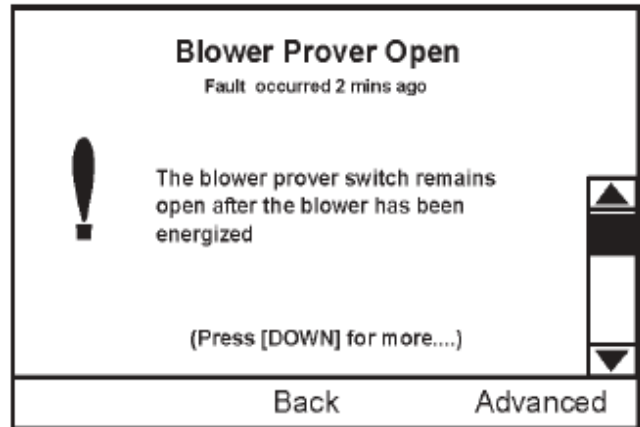

Advanced Diagnostic Information

When a fault or warning has been declared, advanced information can be found in the control. By pressing the Advanced button, detailed information can be found regarding diagnosing and resolving the problem.

WARNING: Usage of the Advanced information requires ability equivalent to that of a licensed tradesmen in the field involved.

ULTRAFORCE COMMERCIAL GAS WATER HEATER SUF 120 thru 400 SERVICE HANDBOOK

ACCESS TO THE CURRENT FAULT OR WARNING

When a fault or warning has been detected by the control it will automatically be displayed on the screen and the back light will blink. If you choose to leave the current fault or warning by pressing the **Back** key, you can always return to the fault through the display menu through the menu.

ACTION:

Press the **DOWN** button for more information.

DISPLAY:

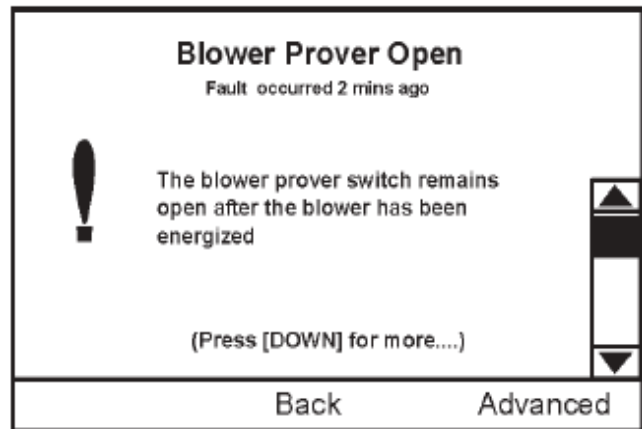
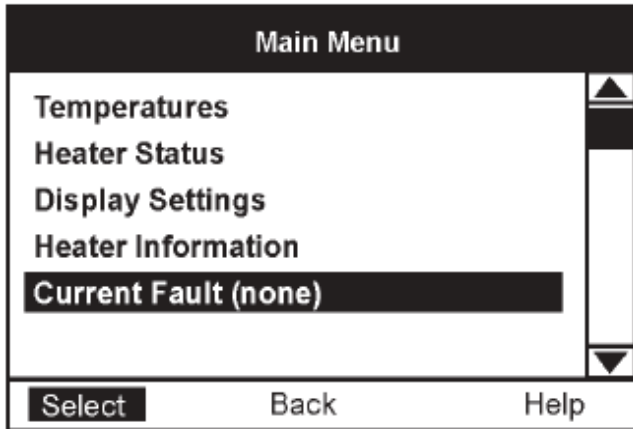

ACTION:

To get to the current fault information screen, press **Menu**.

DISPLAY:

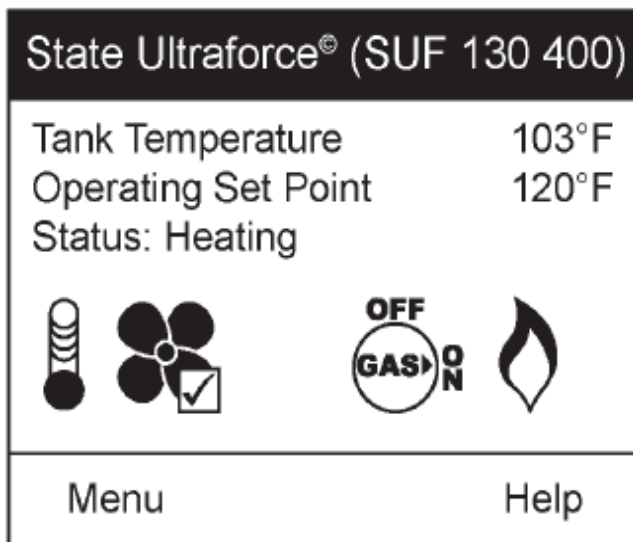

ULTRAFORCE COMMERCIAL GAS WATER HEATER SUF 120 thru 400 SERVICE HANDBOOK

VIEWING THE FAULT HISTORY - VIEWING INFORMATION ABOUT THE HEATER

The controller for this water heater will store a history of **ten** of the last **Fault and Warning** conditions that occurred. This is stored in the Fault History. The information about the fault or warning will include diagnostic information as well as an estimate of how long ago the fault occurred.

ACTION:

Press the **SELECT** button for more information.

DISPLAY:

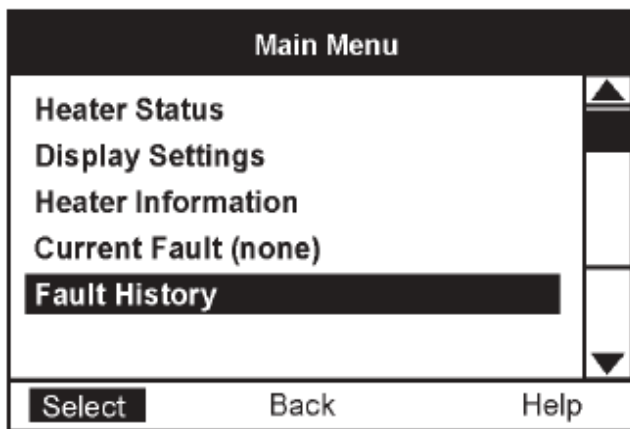

ACTION:

Press the **DOWN** key to scroll through the fault history. If you select a specific fault or warning, you may press the **VIEW** button to view details regarding this fault.

DISPLAY:

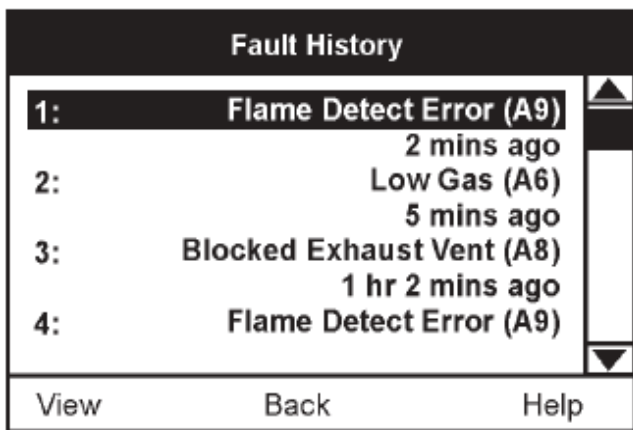

Viewing Information About the Water Heater

The control for this water heater monitors many different aspects of the water to ensure safe and optimal operation. Much of the information monitored is available to view in two areas of the control. The first is the **"Heater Status"** and; the second is **"Heater Information."**

These items can be selected through the desktop menu. In these menus, detailed information about the water heater and the current status of specific conditions can be found.

ULTRAFORCE COMMERCIAL GAS WATER HEATER SUF 120 thru 400 SERVICE HANDBOOK

CONTROL SEQUENCE (TYPICAL ALL MODELS)

TYPICAL SEQUENCE

1. When the control is powered it should display “waiting for connection” and “UIM v2.06”*. The manufacturer and unit model will be next. The next display will include water temperature, temperature setting and heater status.

* This number may change as software revisions are made.

2. The control performed selected system diagnostic checks immediately upon power up. This includes confirming the proper state of the air/gas switches and ECO limit device and powered anodes.

3. If the control determines that the actual water temperature inside the tank is below the programmed temperature set-point less the differential, a call for heat is activated.

4. If all checks are successfully passed, the combustion blower is energized for the pre-purge cycle.

5. When the pre-purge cycle is complete, power is applied to the igniter element for the igniter warm-up period.

6. At the conclusion of the igniter warm-up period, the gas valve will open, allowing gas to enter the burner chamber.

7. The igniter will remain on for a short predetermined time period, then will be turned off.

8. The control will monitor the flame sense probe to confirm a flame is present. If a flame is not verified within predetermined time period, the gas valve will immediately be closed, and the blower will continue to run for approximately 30 seconds inter-purge. The control will try for ignition two more times before lockout.

9. If a flame is confirmed, the control will enter the heating mode where it will continue heating the tank water until the set point temperature plus differential is reached. At this point, the gas valve is closed and the control enters the post-purge cycle.

10. The combustion blower will run for the duration of the post purge cycle to purge the system of all combustion gases. When the post purge cycle is complete, the blower is de-energized and will coast to a stop.

11. The control will now enter the idle state while continuing to monitor the internal tank water temperature and the state of other system devices. If the temperature drops below the set-point value less differential, the control will automatically return to step 2 and repeat the entire operating cycle.

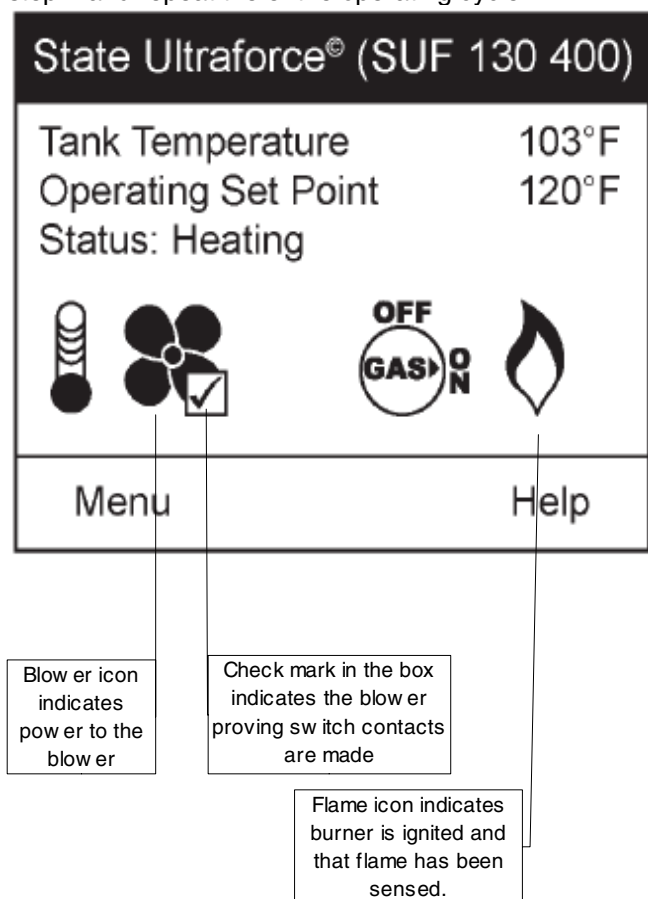

ULTRAFORCE COMMERCIAL GAS WATER HEATER
SUF 120 thru 400 SERVICE HANDBOOK

CONTROL SEQUENCE FLOW CHART

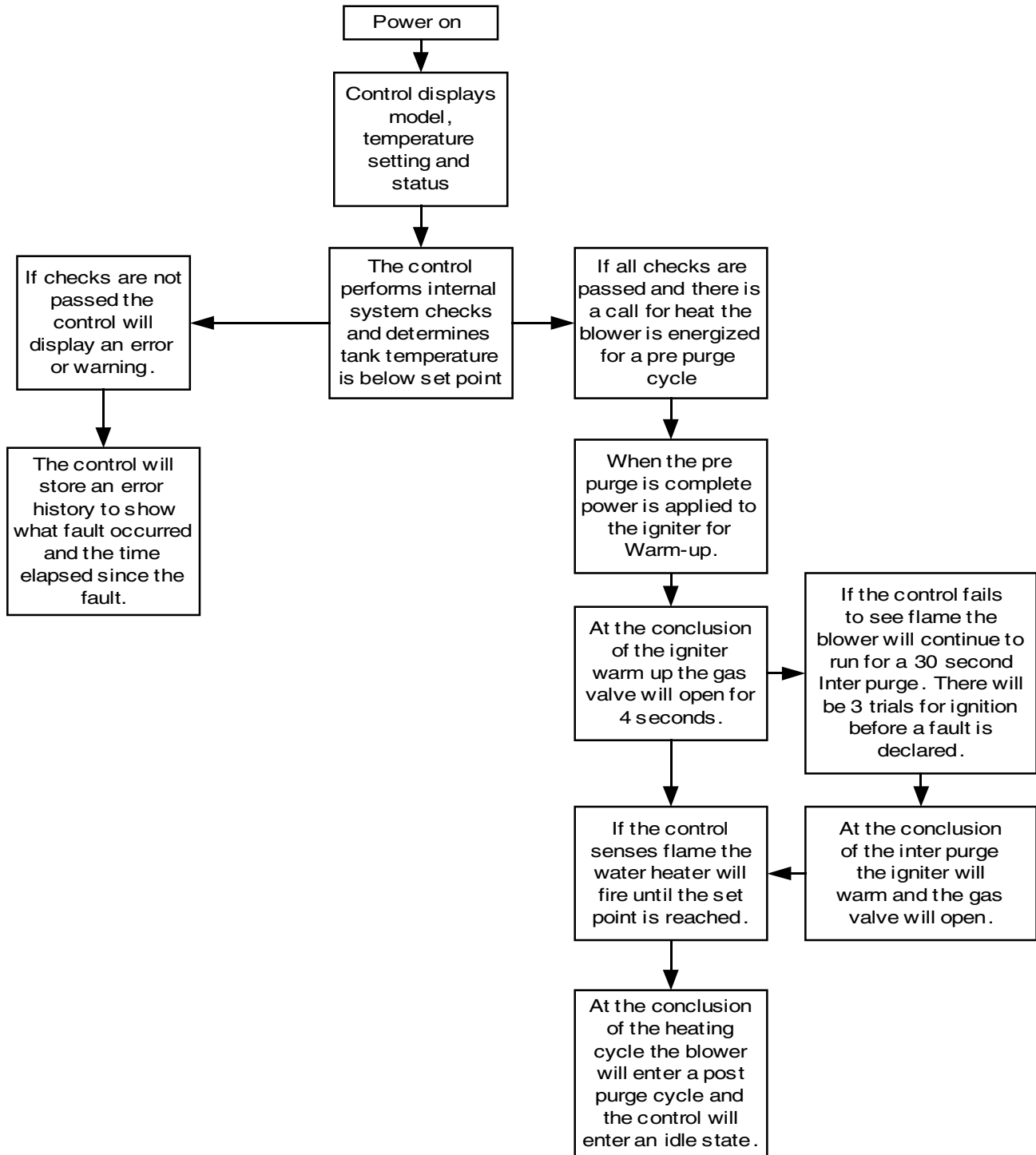

ULTRAFORCE COMMERCIAL GAS WATER HEATER SUF 120 thru 400 SERVICE HANDBOOK

CONTROLS – CENTRAL CONTROL BOARD – CCB

The Central Control Board or CCB is contained in the housing shown below. Access to the board and the wiring harness plugs can be accomplished by removing two Phillips screws holding the cover.



Remove these screws to release cover

The CCB is controlled by the settings given through the desk top menu (UIM). The CCB also monitors all pressure switches, the hot surface igniter, tank temperatures, the gas valve, the anodes, and the flame sensor.

The CCB directly controls blower speed on the SUF199 and 250 models and indirectly controls blower speed on the SUF 400 by means of a Variable Frequency Drive (see page 33).

Note: Improper operation may be the result of a loose connection. Please check all wiring connections and the power supply to the water heater.

This view shows the cover removed from the CCB.



This is the back of the UIM.



ULTRAFORCE COMMERCIAL GAS WATER HEATER SUF 120 thru 400 SERVICE HANDBOOK

CONTROLS – GAS VALVE SUF 120

The gas control valve on the SUF 120 has a built in adjustable pressure regulator. The adjustment screw is accessed by removing the cap screw in the regulator in the illustration.

Inlet gas pressure may be read at the inlet pressure tap only if the manual shut off valve (gas cock) is in the "ON" position. Leaving the knob in the "OFF" position will not allow the burner to fire and will generate a fault code on the UIM (Universal Interface Module).

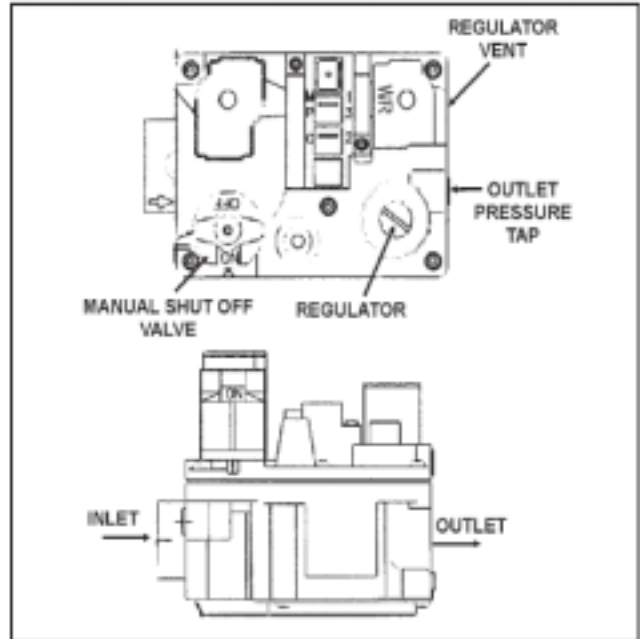

CONTROLS – GAS VALVE SUF 150

The gas control valve on the SUF 150 is has a built in pressure regulator. The regulator may be adjusted by removing the cap screw marked "regulator" in the illustration.

Inlet gas pressure may be read at the inlet pressure tap only if the manual switch is set the "ON" position.



ULTRAFORCE COMMERCIAL GAS WATER HEATER SUF 120 thru 400 SERVICE HANDBOOK

CONTROLS – GAS VALVE SUF 199 and 250

ADJUSTMENT PROCEDURE: GAS PRESSURE SUF 199 AND 250 MODELS

Once the unit is installed and filled with water and the inlet pressures confirmed, simply turn the switch "on" and observe operation. Cycle the unit "off" and "on" several times to ensure proper operation.

IMPORTANT NOTE

THE SUF 199 AND 250 MODELS INCORPORATE A NEW GAS CONTROL, WHICH OPERATES AT A MANIFOLD PRESSURE OF 0"W.C. (0 kPa) FOR BOTH NATURAL AND PROPANE GAS. SEE THE GAS PRESSURE CHART ON PAGE 4. THESE MODELS ARE CONFIGURED PRIOR TO BEING SHIPPED FROM THE FACTORY AND NO ADJUSTMENTS ARE NECESSARY PRIOR TO STARTUP. THE CONTROLLER MONITORS THE AIR FLOW AND MAKES ADJUSTMENTS TO THE FAN SPEED WHICH IN EFFECT CONTROLS THE AMOUNT OF GAS FLOW. THEREFORE, THE UNIT WILL SELF ADJUST TO ACQUIRE THE CORRECT AMOUNT OF INPUT.

Supply gas pressure to the water heater for natural gas should be between a maximum of 10.5" (2.59kPa for natural gas) W.C. (14.0"/3.45kPa for propane) and a minimum as shown on page 4: that is, for Natural Gas 4" (.98kPa) W.C. And 9.0" (1.97kPa) for Propane Gas. The inlet gas pressure must not exceed the maximum value.

A supply gas pressure regulator (service regulator) must be installed on the gas supply line within 10' (305 cm) of the unit.

HIGH ALTITUDE INSTALLATION

The SUF 199 and 250 models are suitable for installation up to 10,100 feet above sea level with no adjustments.

GAS ORIFICE

The SUF 199 and 250 models do not have a natural gas orifice. A .230" orifice is used on LP gas models.

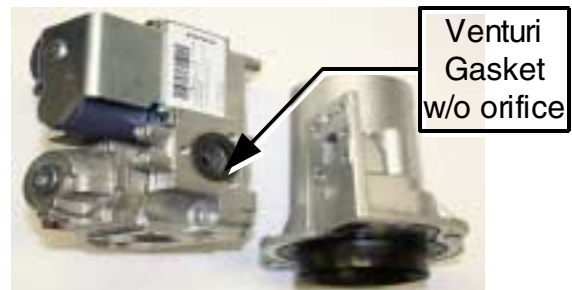

Gas Control Without Orifice

Natural Gas

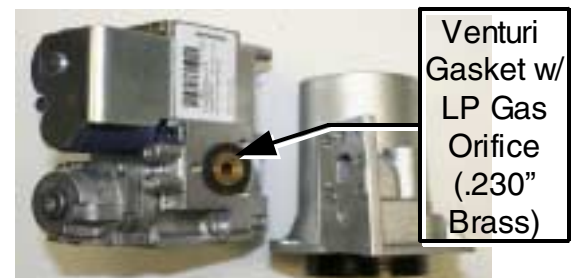

Gas Control with .230" LP Orifice

ULTRAFORCE COMMERCIAL GAS WATER HEATER SUF 120 thru 400 SERVICE HANDBOOK

CONTROLS – GAS VALVE SUF 199 and 250

Pressure readings may be taken on the gas valve by connecting to the pressure ports on the valve. The manifold pressure on this valve is 0" w.c. (0kPa) when the water heater is running. Refer to the gas pressure chart on page 4.

Note: Tubing shown on pressure connections is installed for manometer connections. It is not supplied with the water heater.

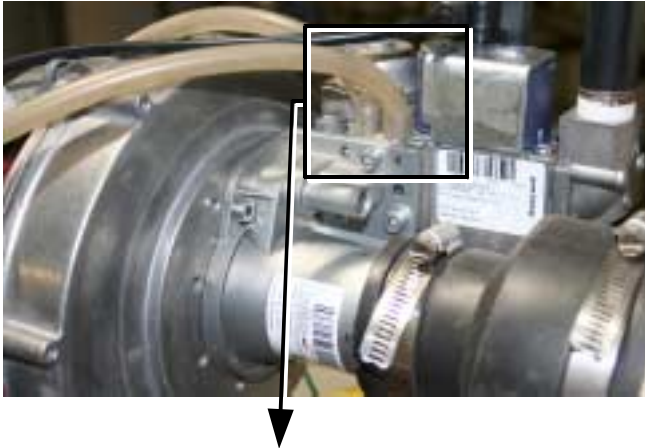

WARNING: Do not attempt adjustments on this gas valve unless you have a combustion analyzer. Contact the "help line" listed on the water heater for assistance.



Manifold
gas
Pressure
0" WC
(0kPa)

Supply
gas
pressure

**ULTRAFORCE COMMERCIAL GAS WATER HEATER
SUF 120 thru 400 SERVICE HANDBOOK**

CONTROLS – GAS VALVE , ORIFICE CHART– SUF300,400,

The gas control valve has a built in field adjustable pressure regulator. The regulator may be adjusted by removing the cap screw marked “regulator”. The adjustment screw is underneath. The gas valve for the SUF Natural gas model is shown above. This is a 24V. solenoid operated gas valve.

ORIFICE CHART – SUF 300,400,

Model	300	400
Natural .27	4”	.314”
LP	.189”	.219”

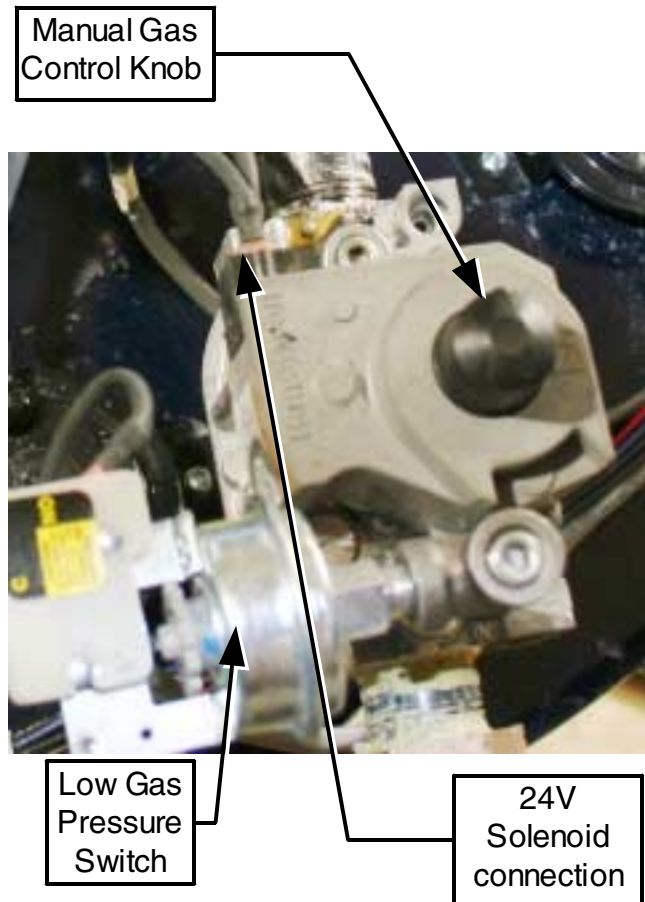

Refer to the replacement parts information at the back of this manual for part numbers for Natural and LP gas valves for all SUF 300, 400, and models.

ULTRAFORCE COMMERCIAL GAS WATER HEATER SUF 120 thru 400 SERVICE HANDBOOK

CONTROLS – PRESSURE SWITCHES – ALL MODELS

All SUF models are provided with four pressure switches. These switches are essential to the safe and proper operation of the unit. The switches are wired to the central control board (CCB) individually and each is monitored individually. The (CCB) is set up to shut the unit down whenever there is a failure of any of the switches and **declare a fault** for each individual switch. It is important to understand the purpose of each switch.

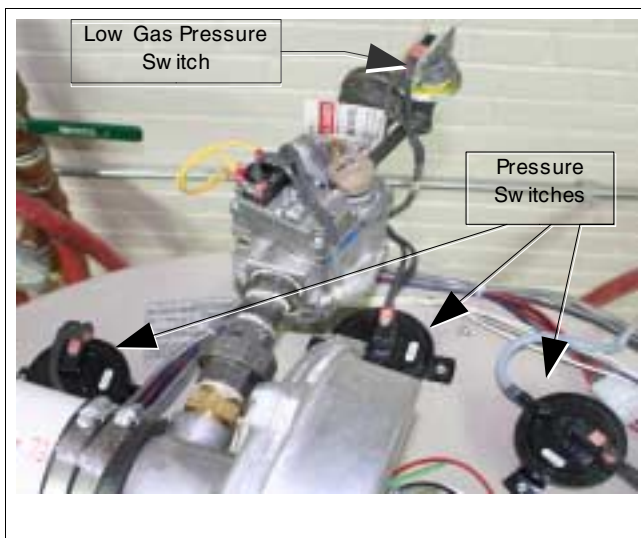

BLOWER PROVING SWITCH

The Blower Proving Switch is provided on the heater to verify that the fan is operating. It is a positive pressure switch whose electrical contacts are **normally open**. The blower proving switch electrical contacts will **close on a rise in pressure** as the blower increases the pressure in the burner. This switch is connected to the burner tap by a piece of Tygon (soft plastic) tubing. This tubing must be connected in order for the switch to close the electrical contacts. The controller requires that the electrical contacts on this pressure switch be open before it will allow the blower to come on. The control will declare a fault on the UIM if either condition occurs.

BLOCKED OUTLET PROVING SWITCH

The blocked outlet proving switch electrical contacts are **normally closed**. The blocked outlet proving switch electrical contacts will **open on a rise in pressure**. Check to see if the condensate is allowed to flow freely from the exhaust elbow and for obstructions in the exhaust venting and exhaust vent terminal. Also check that the equivalent feet of vent pipe for the specific model has not been exceeded. Check the vent length tables on page 9.

BLOCKED INLET PROVING SWITCH

The Blocked Inlet Proving switch electrical contacts are **normally closed**. The blocked inlet proving switch electrical contacts will open when an **increase in negative pressure (vacuum)** occurs in the intake vent pipe. The switch is connected to the pressure tap on the PVC flange connected to the inlet of the blower. When this switch prevents the unit from igniting, most likely the intake is blocked by some means. Verify that the air intake pipe and air intake vent terminal are free of obstructions that may prevent air from entering the unit. Also check that the equivalent feet of vent pipe for the specific model has not been exceeded. Check the vent length tables on page 9.

LOW GAS PRESSURE SWITCH

The Low Gas Pressure Switch electrical contacts are **normally open**. The low gas pressure switch electrical contacts will **close on a rise pressure**. The contacts will open when the pressure falls below the fixed set point. If this happens during a heating cycle the burner will be shut down and a fault will be declared on the UIM.

**ULTRAFORCE COMMERCIAL GAS WATER HEATER
SUF 120 thru 400 SERVICE HANDBOOK**

CONTROLS – PRESSURE SWITCHES – SUF 120 through 250

BLOCKED INLET PRESSURE SWITCH	
MODEL	PRESSURE
All	0.85" WC
Normally Closed / Open on a Rise in Pressure	
Tolerance +/- .05" WC	

LOW GAS PRESSURE SWITCH	
MODEL	PRESSURE
Natural	4.0" WC
LP	8.0" WC
Normally Open / Close on a Rise in Pressure	
Tolerance +/- .05" WC	

BLOCKED OUTLET PRESSURE SWITCH	
MODEL	SWITCH
120N	+1.2" WC
150N	+0.98" WC
199N	+1.06" WC
250N	+4.0" WC
120LP	+1.3" WC
150LP	+1.3" WC
199LP	+4.0" WC
250LP	+2.0" WC
Normally Closed / Open on a Rise in Pressure	
Tolerance +/- .05" WC	

BLOWER PROVER PRESSURE SWITCH	
MODEL	PRESSURE
All	+ .075" WC
Normally Open / Close on a Rise in Pressure	
Tolerance +/- .05" WC	

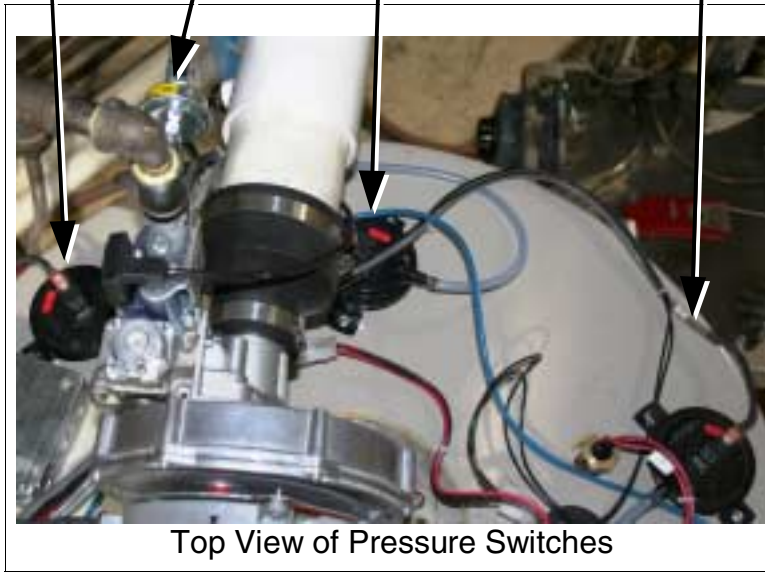

Note: Check the website www.statewaterheaters.com for Technical Bulletin S023-06 "Air Pressure Switches" under "Literature/Service Handbooks"

**ULTRAFORCE COMMERCIAL GAS WATER HEATER
SUF 120 thru 400 SERVICE HANDBOOK**

CONTROLS – PRESSURE SWITCHES – SUF 300,400,

BLOCKED INLET PRESSURE SWITCH	
MODEL	PRESSURE
300	-.085" WC
400	-1.25" WC
500	-1.35" WC
Normally Closed/ Open on a Rise in Pressure Tolerance +/- .05" WC	

LOW GAS PRESSURE SWITCH	
MODEL	PRESSURE
Natural	+4.6" WC
LP	+9.0" WC
Normally Open/ Close on a Rise in Pressure Tolerance +/- .05" WC	

BLOWER PROVER PRESSURE SWITCH	
MODEL	PRESSURE
300	+1.0" WC
400	+2.5" WC
500	+4.5 " WC
Normally Open / Close on a rise in Pressure Tolerance +/- .05" WC	

BLOCKED EXHAUST PRESSURE SWITCH	
MODEL	PRESSURE
300	+1.15" WC
400	+1.39" WC
500	+1.77" WC
Normally Closed / Open on a Rise in Pressure Tolerance +/- .05" WC	

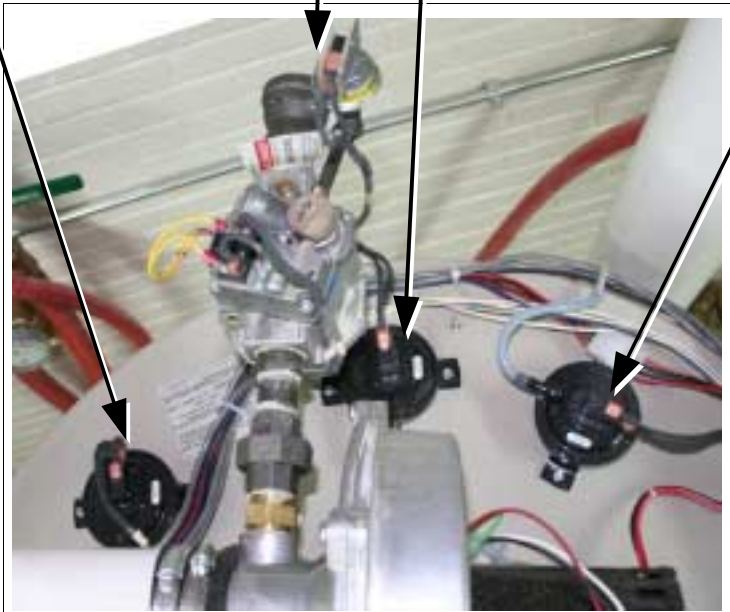

Top View of Pressure Switches
SUF 300,400,

Note: Check the website www.statewaterheaters.com for Technical Bulletin S023-06 "Air Pressure Switches" under "Literature/Service Handbooks"

ULTRAFORCE COMMERCIAL GAS WATER HEATER SUF 120 thru 400 SERVICE HANDBOOK

CONTROLS – CONNECTIONS, IGNITER, FLAME SENSOR, SIGHT GLASS, POWERED ANODES

The connections for the hot surface igniter and the flame sense rod are shown below. Also shown is the burner sight glass. These features are typical for all models.

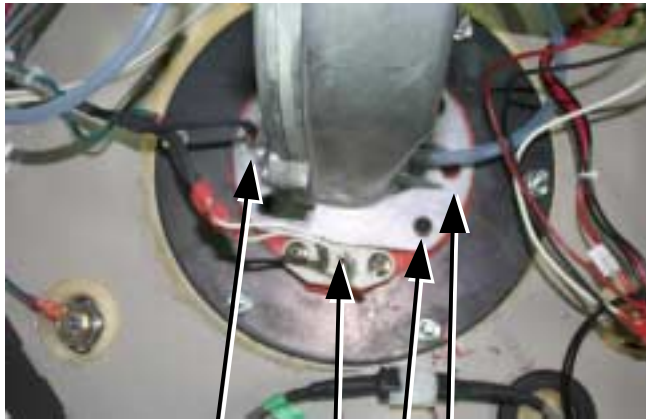

- Flame Sensor
- Hot Surface Igniter
- Burner Mounting Bolts
- Burner Sight Glass

The new Ultra Force commercial water heater is equipped with powered anodes. These anodes never need replacement. The CCB monitors the current through the anodes and will declare a fault if there is a disconnected wire or if there is no water in the tank.



Powered anode connection

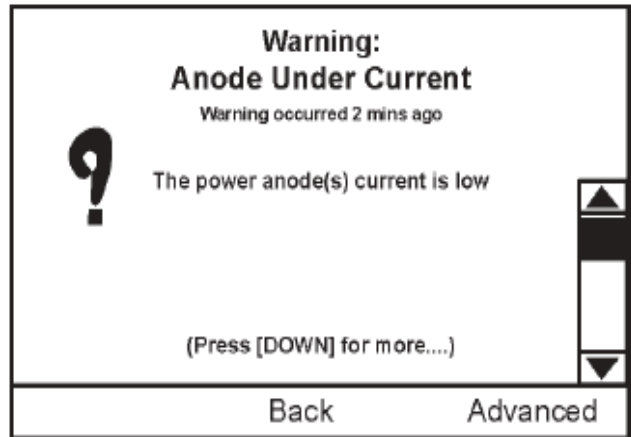

**ULTRAFORCE COMMERCIAL GAS WATER HEATER
SUF 120 thru 400 SERVICE HANDBOOK**

HOT SURFACE IGNITER / FLAME SENSOR / CONTROL TIMING

HOT SURFACE IGNITER

This water is equipped with an electric hot surface igniter. The igniter material is silicone carbide and should not be handled with bare hands because of possible damage to the igniter.

The normal ohm reading at 77°F is listed between 40 and 70 ohms. The minimum igniter current monitored by the CCB is 2.7 amps. Once this threshold is met a check mark will appear by the igniter icon in the UIM (display).



FLAME SENSOR

This water heater is equipped with an electronic flame sensor. The flame sensor senses flame by passing a small electric current through the burner flame. This type of flame sensing is also known as flame rectification. The CCB is looking for a minimum current of .7 micro amperes for the water heater to operate. Once this current is established the UIM will display a flame icon.



CONTROL TIMING

Pre-purge	25 seconds
Igniter Warm-up	17 seconds
Trial for ignition Gas Control Open	5 seconds
Inter/Post Purge	30 seconds

ULTRAFORCE COMMERCIAL GAS WATER HEATER SUF 120 thru 400 SERVICE HANDBOOK

BLOWER SPEED CONTROL SUF 199 AND 250

The input of the SUF 199 and SUF 250 is determined by the blower. The input of the water heater may be determined by clocking the meter as shown on page 5 or by making sure the blower is receiving the proper Hz signal. The blower rpm is controlled by the Central Control Board (CCB). The signal to the blower may be measured by attaching a MULTIMETER that has a Hertz (Hz) setting as shown in the illustration to the right. If the Hz signal is within +/-

Meter black lead is connected to ground (not shown) and the red lead is connected to an open terminal on blower speed control connection.

Model	Hz	Hz
199 N	133	87
250 N	133	87
199 LP	200	156
250 LP	266	96

Note: Removing the plug shown in the illustration will cause the blower to accelerate and the input of the water heater to increase to a much higher rate.



Meter red probe
connected to
open terminal on
plug

ULTRAFORCE COMMERCIAL GAS WATER HEATER SUF 120 thru 400 SERVICE HANDBOOK



VARIABLE FREQUENCY DRIVE – SUF 400

The Ultra Force SUF 400 model has a **variable frequency drive (VFD)** that controls the rpm of the blower motor. The VFD receives a signal from the central control board that instructs the VFD to transmit the proper frequency to the blower to produce the proper blower speed and proper input.

Three conditions must be met for the frequency drive to start the blower:

1. 120VAC must be supplied to the VFD 120VAC input.
2. The ignition control board closes an enable circuit – terminals **LI1** and **+15V**
3. The ignition control board sends a 1-10VDC instruction – terminals **0V** and **AI1**. See table on the next page for voltage and frequency information.

GROUND HOT NEUTRAL

		
G	R/L1	N

VARIABLE FREQUENCY DRIVE

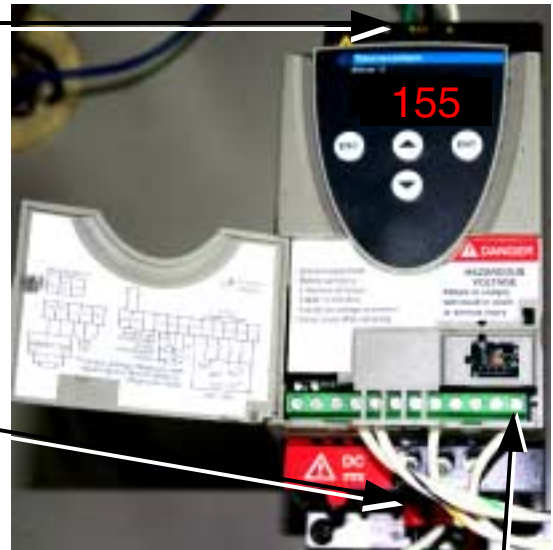













BLOWER MOTOR WIRES

BLACK WHITE RED

		
U/T1	V/T2	W/T3

NOTE: BE SURE TO MATCH WIRE COLORS WHEN CONNECTING BLOWER WIRES OR BLOWER MAY RUN BACKWARD AND CAUSE A FAULT.

											
RC	RA		0V	AI1	+5V	DO	LI1	LI2	LI3	LI4	+15V
↑				↑		↑				↑	
1-10 VDC Speed Instruction						Enable Disable Circuit					

ULTRAFORCE COMMERCIAL GAS WATER HEATER SUF 120 thru 400 SERVICE HANDBOOK

VARIABLE FREQUENCY DRIVE - BLOWER SPEED AND PRESSURE READINGS

The instructions for the VFD are sent from the CCB to in the form of a DC current. The chart below lists the current readings, the frequency signal displayed by the VFD, and the pressure switch settings needed for the CCB to let the burner operate. The frequency numbers displayed may vary slightly with slight variations in the DC voltage generated by the CCB. If the water heater exhibits poor run characteristics check the frequency display. If the frequency is more than 5% out of range, check the DC volt signal at the terminals shown on page 33.

Voltage – Frequency – Speed Instructions - VFD			
Model	SUF 400		
Instruction Volts DC Terminals 0V and A11	0 – 10 VDC		
	Volts	Frequency	Pressure W.C.”
Ignition (low speed)	7.53	150 Hz+/- 2	5.3”
Purge (high speed)	7.77	155 Hz+/- 2	5.85”
VFD Part Number	197500-000		

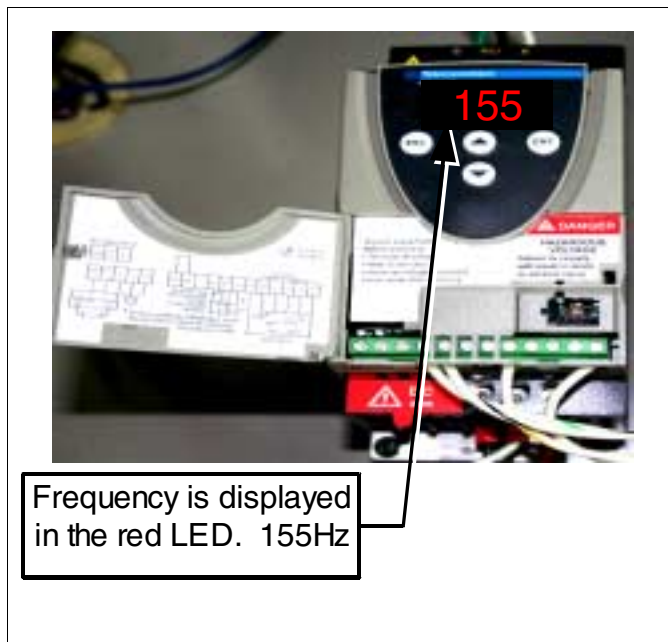

ULTRAFORCE COMMERCIAL GAS WATER HEATER SUF 120 thru 400 SERVICE HANDBOOK

WIRING DIAGRAM – SUF 120 – 300

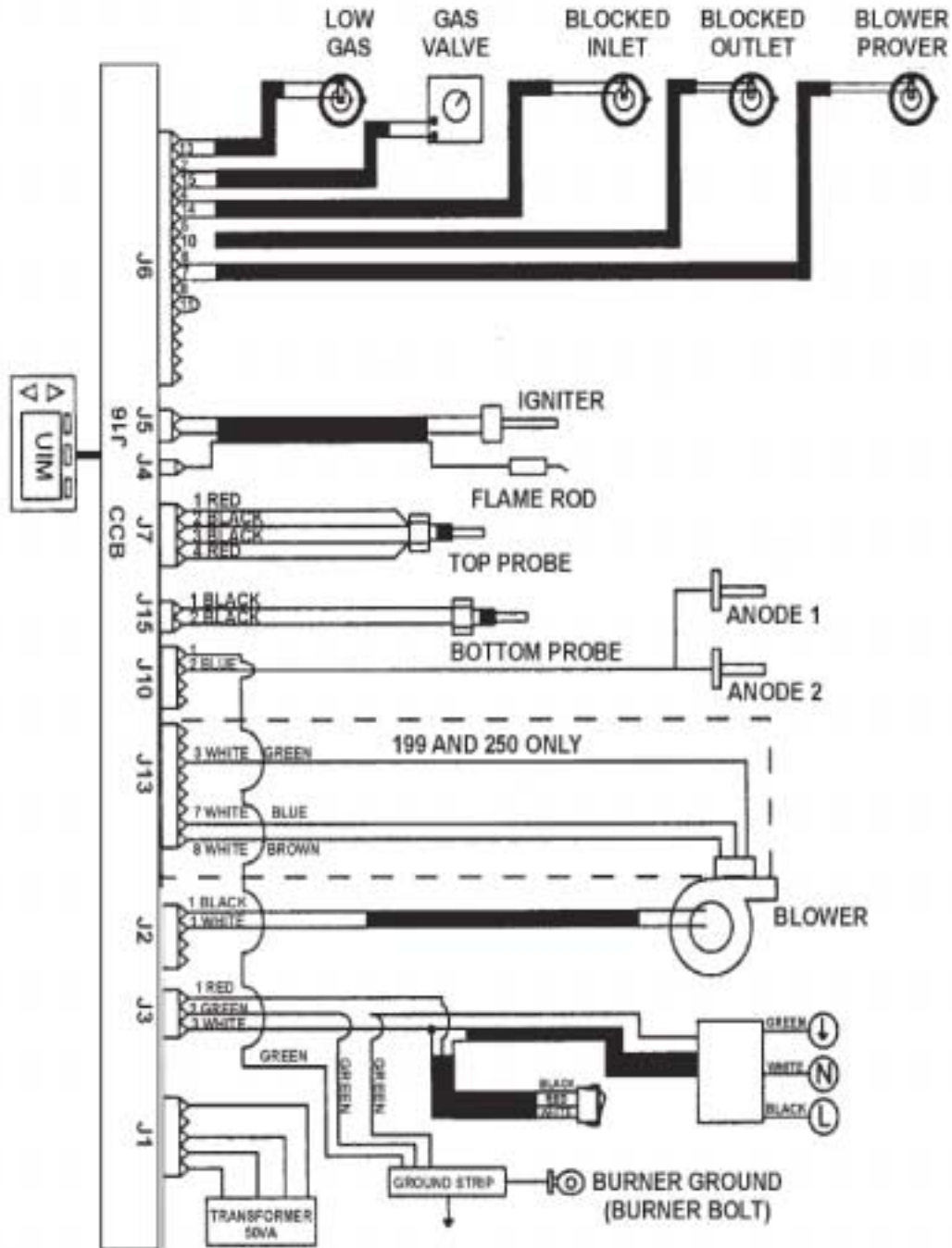

ULTRAFORCE COMMERCIAL GAS WATER HEATER SUF 120 thru 400 SERVICE HANDBOOK

WIRING DIAGRAM – SUF 400,

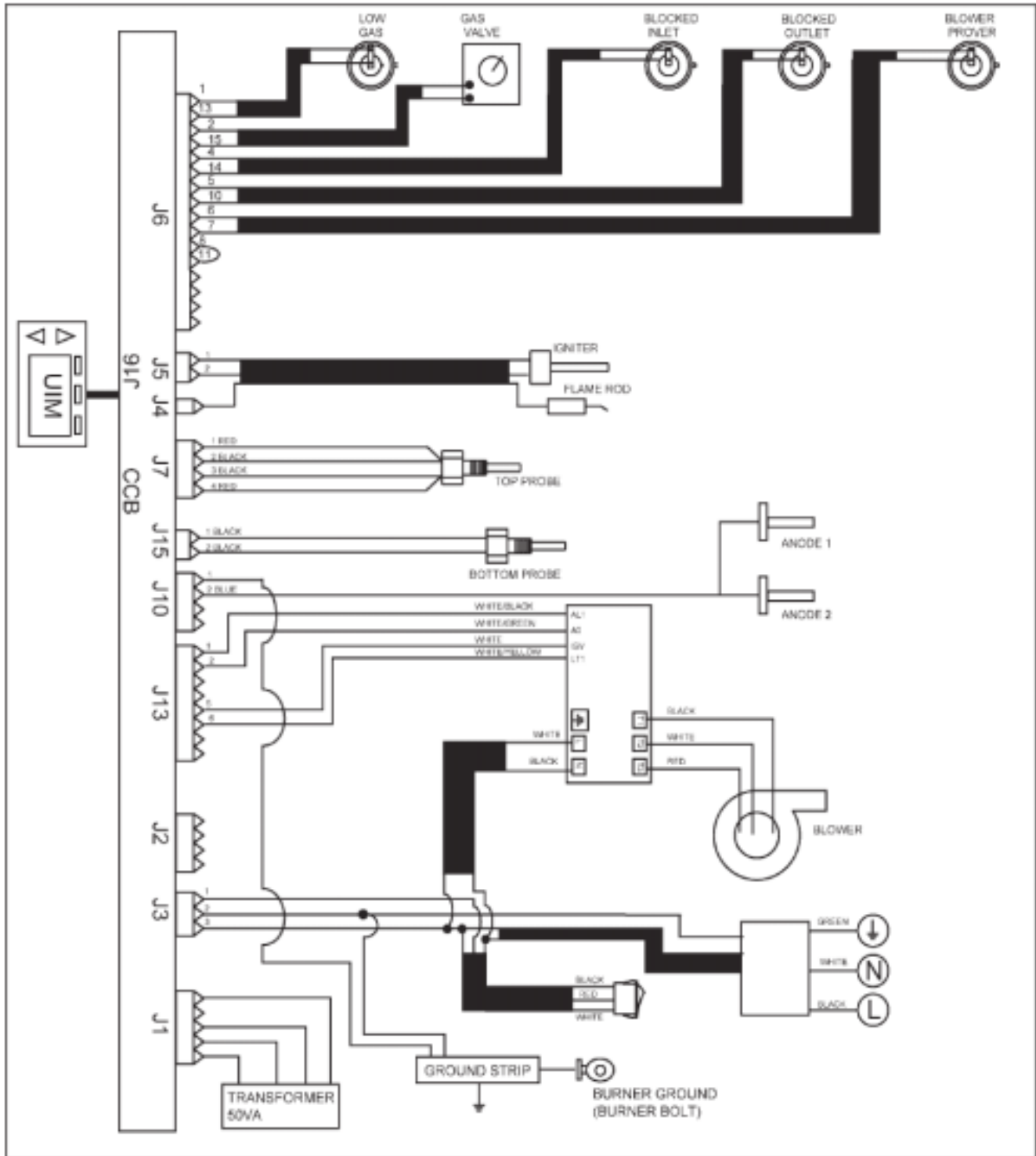



500 Tennessee Waltz Parkway
Ashland City, TN 37015
www.statewaterheaters.com

Free Manuals Download Website

<http://myh66.com>

<http://usermanuals.us>

<http://www.somanuals.com>

<http://www.4manuals.cc>

<http://www.manual-lib.com>

<http://www.404manual.com>

<http://www.luxmanual.com>

<http://aubethermostatmanual.com>

Golf course search by state

<http://golfingnear.com>

Email search by domain

<http://emailbydomain.com>

Auto manuals search

<http://auto.somanuals.com>

TV manuals search

<http://tv.somanuals.com>