

MODELS TPG-140-140 thru 600-2500

INCLUDING TPX/TPO & TPD

COMMERCIAL GAS, OIL AND GAS/OIL TANK-TYPE WATER HEATERS

• INSTALLATION • OPERATION • SERVICE • MAINTENANCE • LIMITED WARRANTY



ASME



WARNING: If the information in these instructions is not followed exactly, a fire or explosion may result causing property damage, personal injury or death.

- Do not store or use gasoline or other flammable vapors and liquids in the vicinity of this or any other appliance.
- **WHAT TO DO IF YOU SMELL GAS**
 - Do not try to light any appliance.
 - Do not touch any electrical switch; do not use any phone in your building.
 - Immediately call your gas supplier from a nearby phone. Follow the gas supplier's instructions.
 - If you cannot reach your gas supplier, call the fire department.
- Installation and service must be performed by a qualified installer, service agency or the gas supplier.



CAUTION

TEXT PRINTED OR OUTLINED IN RED CONTAINS INFORMATION RELATIVE TO YOUR SAFETY. PLEASE READ THOROUGHLY BEFORE USING APPLIANCE.



WARNING – PROPANE MODEL

Water heaters for propane gas are different from natural gas models. A natural gas heater will not function safely on propane gas and no attempt should be made to convert a heater from natural gas to propane gas.

Propane gas must be used with great caution. It is highly explosive and heavier than air. It collects first in the low areas making its odor difficult to detect. If propane gas is present or even suspected, do not attempt to find the cause yourself. Ventilate the room, then call your gas supplier or service agent. Keep area clear until a service agent has been called.

PLACE THESE INSTRUCTIONS ADJACENT TO HEATER AND NOTIFY OWNER TO KEEP FOR FUTURE REFERENCE

FOREWORD

This manual is intended to be used in conjunction with other literature provided with the heater. This includes power burner and related gas control information. It is important that this manual and the additional publications be reviewed in their entirety before beginning any work.

The installation should be made in accordance with the regulations of the local code authorities and utility companies, which pertain to this type of water heating equipment.

MAKE SURE the fuel on which the heater will operate is the same as that specified on the heater model and rating plate.

THESE HEATERS MUST NOT BE INSTALLED ON COMBUSTIBLE FLOORS.

Instructions for periodic testing of various water heater safety devices are included in section titled COMBUSTION

ARRANGEMENT REQUIREMENTS AND SERVICE RECOMMENDATIONS.

In the absence of local codes, the installation must comply with the instruction as outlined in the latest publication of ANSI booklet NFPA-54/ANSI Z223.1 "NATIONAL FUEL GAS CODE", NFPA No. 70 "NATIONAL ELECTRICAL CODE", or Canadian Gas Association booklet CAN 1-B149.1 or CAN 1-B149.2 for Canadian Installations also be followed.

These manuals can be purchased from the American Gas Association Laboratories, 8501 East Pleasant Valley Road, Cleveland, OH 44131 or the National Fire Protection Association, 1 Batterymarch Park, Quincy, MA 02269-9101, or Canadian Gas Association Laboratories, 55 Scarsdale Road, Don Mills, Ontario, Canada M3B 2R3.

TABLE OF CONTENTS

	PAGE		PAGE
FOREWORD	2	Gas Piping	7-8
IDENTIFICATION	2	Purging	8
GENERAL SAFETY INFORMATION	3	Gas Meter Size (City Gases Only)	8
Precautions	3	Gas Pressure Regulator	8
Grounding Instructions	3	Wiring	8-11
Improper Combustion	3	TWO UNIT MANIFOLD INSTALLATION	11
Liquid Petroleum Models	3	OPERATION	11
Extended Non-Use Periods (TPG Models Only)	3	Important	11
Insulation Blankets	3	General	11
High Altitude Installations	3-4	Filling	11
FEATURES	4	Combustion Air Requirements	
Water Temperature Control	4	And Service Recommendations	11-12
INSTALLATION INSTRUCTIONS	4	MAINTENANCE	12
Required Ability	4	General	12
Uncrating	4-5	Flushing	12
Locating the Heater	5	Draining	12
Leveling	5	Sediment Removal	12
Clearances	5	Lime Scale Removal	12-13
Air Requirements	5-6	Relief Valve	13
Thermal Expansion (Closed System)	6	Power Burner	13-14
Venting	6	Cleaning Flues - TPO & TPD Only	14
Vent Connector	6	Vent Systems	14
Barometric Draft Control Assembly	6-7	Barometric Draft Control	14
Water Line Connections	7	TROUBLESHOOTING	14-15
Thermometers (Not Supplied)	7	Replacement Parts	15
Relief Valve	7	LIMITED WARRANTY	16

This manual is supplemented by the power burner manual. All information, including start-up and maintenance relating to the burner, can be found in that manual.

IDENTIFICATION

The heater and burner mounted identification plates provide valuable information. When ordering parts or inquiring about a unit, be sure to include serial number, model number and type of fuel.

MFD. FOR STATE INDUSTRIES, INC.
500 LINDAHL PARKWAY, ASHLAND CITY, TN 37015

SERIAL NO. <input type="text"/>	MODEL NO. <input type="text"/>	CAP. U.S. GAL. <input type="text"/>
BTU/HR. INPUT <input type="text"/>	TYPE OF FUEL <input type="text"/>	MANIFOLD PRESS. - "W.C. <input type="text"/>
GPH INPUT <input type="text"/>	TYPE OF OIL <input type="text"/>	NOZZLE PRESS. - PSI <input type="text"/>
RECOVERY CAP. GAL./HR. (100°F RISE) <input type="text"/>	WORKING PRESS. <input type="text"/>	TEST PRESS. <input type="text"/>
VOLTAGE PHASE <input type="text"/>	AMPERES <input type="text"/>	HORSEPOWER <input type="text"/>

09065013T

GENERAL SAFETY INFORMATION

PRECAUTIONS

DO NOT USE THIS APPLIANCE IF ANY PART HAS BEEN UNDERWATER. Immediately call a qualified service technician to inspect the appliance and to replace any part of the control system and any gas control which has been under water.

IF THE UNIT IS EXPOSED TO THE FOLLOWING, DO NOT OPERATE HEATER UNTIL ALL CORRECTIVE STEPS HAVE BEEN MADE BY A QUALIFIED SERVICEMAN.

1. EXTERNAL FIRE.
2. DAMAGE.
3. FIRING WITHOUT WATER.
4. SOOTING.

Heater must be protected from freezing downdrafts during shutdown periods.

GROUNDING INSTRUCTIONS

This water heater must be grounded in accordance with the National Electric Code and/or local codes. These must be followed in all cases.

This water heater must be connected to a grounded metal, permanent wiring system; or an equipment grounding conductor must be run with the circuit conductors and connected to the equipment grounding terminal or lead on the water heater.

CHEMICAL VAPOR CORROSION



WARNING

CORROSION OF THE FLUEWAYS AND VENT SYSTEM MAY OCCUR IF AIR FOR COMBUSTION CONTAINS CERTAIN CHEMICAL VAPORS WHICH BREAK DOWN INTO ACIDS AT HIGH TEMPERATURE. SUCH CORROSION MAY RESULT IN FAILURE AND RISK OF ASPHYXIATION.

Spray can propellants, cleaning solvents, refrigerator and air conditioning refrigerants, swimming pool chemicals, calcium and sodium chloride (water softener salt), waxes, and process chemicals and typical compounds which are potentially corrosive. Do not store products of this sort near the heater. Also, air which is brought in contact with the heater should not contain any of these chemicals. If necessary, uncontaminated air should be obtained from remote or outside sources. The limited warranty is voided when failure of water heater is due to a corrosive atmosphere. (Refer to the limited warranty for complete terms and conditions).

IMPROPER COMBUSTION



WARNING

ATTIC AND/OR EXHAUST FANS OPERATING ON THE PREMISES WITH A WATER HEATER CAN RESULT IN CARBON MONOXIDE POISONING AND DEATH.

OPERATING OF THESE FANS CAN PRODUCE A DOWN DRAFT IN THE AREA OF THE WATER HEATER PREVENTING THE PRODUCTS OF COMBUSTION FROM EXHAUSTING THROUGH THE CHIMNEY OR VENT PIPE.

The venting of the water heater should be inspected by a qualified service technician at the time of installation and periodically thereafter to ensure a down-draft condition does not exist.

DO NOT OBSTRUCT THE FLOW OF COMBUSTION AND VENTILATING AIR. ADEQUATE AIR FOR COMBUSTION AND VENTILATION MUST BE PROVIDED FOR SAFE OPERATION.

LIQUID PETROLEUM MODELS

Water heaters for propane or liquefied petroleum gas (LPG) are different from natural gas models. A natural gas heater will not function safely on LP gas and no attempt should be made to convert a heater from natural gas to LP gas.

LP gas must be used with great caution. It is highly explosive and heavier than air. It collects first in the low areas making its odor difficult to detect at nose level. If LP gas is present or even suspected, do not attempt to find the cause yourself. Ventilate the area, then call your gas supplier or service agent. Keep area clear until a service call has been made.

The presence of LP gas may be difficult to detect. The use of a propane gas detector is recommended.

Only trained LP professionals should conduct the required safety checks in accordance with industry standards.

EXTENDED NON-USE PERIODS



WARNING

HYDROGEN GAS CAN BE PRODUCED IN A HOT WATER SYSTEM SERVED BY THIS HEATER THAT HAS NOT BEEN USED FOR A LONG PERIOD OF TIME (GENERALLY TWO WEEKS OR MORE). HYDROGEN GAS IS EXTREMELY FLAMMABLE. To reduce the risk of injury under these conditions, it is recommended that a hot water faucet be opened for several minutes before using any electrical appliance connected to the hot water system. If hydrogen is present, there will probably be an unusual sound such as air escaping through the pipe as the water begins to flow. THERE SHOULD BE NO SMOKING OR OPEN FLAME NEAR THE FAUCET AT THE TIME IT IS OPEN.

INSULATION BLANKETS

Insulation blankets available to the general public for external use on gas water heaters are not approved for use on your State water heater. The purpose of an insulation blanket is to reduce the standby heat loss encountered with storage tank water heaters. Your State water heater meets or exceeds the ASHRAE/IES 90.1b-1992 standards with respect to insulation and standby loss requirements making an insulation blanket unnecessary.



WARNING

The application of an insulation blanket will void the warranty for this water heater. Furthermore, the application of an insulation blanket may interfere with the operation of this water heater, possibly resulting in property damage, injury, or death.

HIGH ALTITUDE INSTALLATIONS

Your State water heater has been designed to operate at altitudes above 2000 feet, provided that requirement was specified at the time of order. The firing rate will be specified on the water heater rating plate.

Note: Some gas utility companies derate the heating value of the supplied gas at high elevations. Your authorized State Start-Up Agent must adjust for actual heating value of the gas at the time of start-up.

FEATURES

WATER TEMPERATURE CONTROL

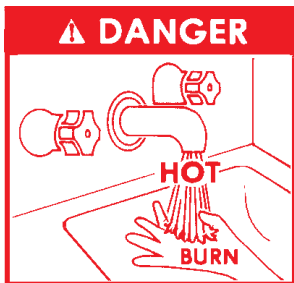

WARNING

THIS WATER HEATER IS EQUIPPED WITH AN ADJUSTABLE THERMOSTAT TO CONTROL WATER TEMPERATURE. HOT WATER TEMPERATURES REQUIRED FOR AUTOMATIC DISHWASHER AND LAUNDRY USE CAN CAUSE SCALD BURNS RESULTING IN SERIOUS PERSONAL INJURY AND/OR DEATH. THE TEMPERATURE AT WHICH INJURY OCCURS VARIES WITH THE PERSON'S AGE AND TIME OF EXPOSURE. THE SLOWER RESPONSE TIME OF CHILDREN, AGED OR DISABLED PERSONS INCREASES THE HAZARDS TO THEM. NEVER ALLOW SMALL CHILDREN TO USE HOT WATER TAP, OR TO DRAW THEIR OWN BATH WATER. NEVER LEAVE A CHILD OR DISABLED PERSON UNATTENDED IN A BATHTUB OR SHOWER.

THE WATER HEATER SHOULD BE LOCATED IN AN AREA WHERE THE GENERAL PUBLIC DOES NOT HAVE ACCESS TO SET TEMPERATURES.

SETTING THE WATER HEATER TEMPERATURE AT 120°F WILL REDUCE THE RISK OF SCALDS. Some states or provinces require settings at specific lower temperatures.

Below you will find listed the appropriate time-to-burn relationship for normal adult skin. Short repeated heating cycles caused by small hot water uses can cause temperatures at the point of use to exceed the thermostat setting by up to 20°F (11°C). If you experience this type of use, you should consider using lower temperature settings to reduce scald hazards.

Temperature Setting	Time to Produce 2nd & 3rd Degree Burns on Adult Skin
180°F (82°C)	Nearly Instantaneous
170°F (77°C)	Nearly Instantaneous
160°F (71°C)	About 1/2 Second
150°F (65°C)	About 1-1/2 Seconds
140°F (60°C)	Less than 5 Seconds
130°F (54°C)	About 30 Seconds
120°F (49°C)	More than 5 Minutes

Valves for reducing point-of-use temperature by mixing cold and hot water are available. Also available are inexpensive devices that attach to faucets to limit hot water temperatures. Contact a licensed plumber or the local plumbing authority.

The water temperature is controlled by two thermostats. One thermostat is located near the top of the tank and the other is in the lower part of the tank. The upper thermostat must be set at least 5°F higher than the lower thermostat. In the case where the water heater has electronic thermostats, this differential has been factory set and cannot be changed.

The thermostat temperature dials are accessible by opening the control compartment cover.

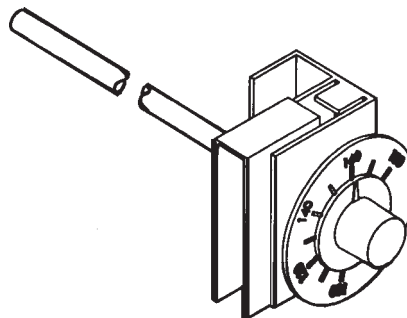

FIGURE 1

A high limit switch interrupts the power burner operation should the water temperature reach 200°F.

The high limit switch must be manually reset by depressing the red button on the front of the control when water temperature drops to about 180°F. The manual reset high limit can be found inside the control compartment.

INSTALLATION INSTRUCTIONS

REQUIRED ABILITY

INSTALLATION OR SERVICE OF THIS WATER HEATER IS REQUIRED TO BE PERFORMED BY AN AUTHORIZED STATE STARTUP AGENT. PLUMBING, AIR SUPPLY, VENTING, GAS SUPPLY AND ELECTRICAL WORK ARE REQUIRED.

UNCRATING

The heater should be moved in the crate as close as possible to the installation site. Depending upon size, shipping weights range from about 1,300 to 4,500 pounds.

The installer should be guided by the instructions furnished with the heater, local codes and utility company requirements. Preference should be given to codes and requirements where they differ from the heater furnished instructions.

Additional publications, which should guide the installer, include:

The latest version of the National Fuel Gas Code, ANSI Z223.1, from American Gas Association Laboratories, 8501 East Pleasant Valley Road, Cleveland, OH 44131.

In Canada – CGA No. B149 (latest version), from Canadian Gas Association Laboratories, 55 Scarsdale Road, Don Mills, Ontario, Canada M3B 2R3.

Code for the installation of Heat Producing Appliances (latest version), from American Insurance Association, 85 John Street, New York, NY 11038.

The latest version of the National Electrical Code, NFPA No. 70. In Canada refer to Canadian Electrical Code C 22.1, from National Fire Protection Association, 1 Batterymarch Park, Quincy, MA 02269-9101.

A clearance of 24" should be maintained from serviceable parts, such as relief valve, power burner, thermostat and drain valve.

LOCATING THE HEATER

When installing the heater, consideration must be given to proper location. Location selected should be as close to the stack or chimney as practicable, with adequate air supply and as centralized with the piping system as possible.

WARNING

THERE IS A RISK IN USING FUEL BURNING APPLIANCES SUCH AS GAS WATER HEATERS IN ROOMS, GARAGES OR OTHER AREAS WHERE GASOLINE, OTHER FLAMMABLE LIQUIDS OR ENGINE DRIVEN EQUIPMENT OR VEHICLES ARE STORED, OPERATED OR REPAIRED. FLAMMABLE VAPORS ARE HEAVY AND TRAVEL ALONG THE FLOOR AND MAY BE IGNITED BY THE HEATER'S IGNITION SYSTEM OR MAIN BURNER FLAMES CAUSING FIRE OR EXPLOSION.

SOME LOCAL CODES PERMIT OPERATION OF GAS APPLIANCES IF INSTALLED 18 INCHES OR MORE ABOVE THE FLOOR. THIS MAY REDUCE THE RISK IF LOCATION IN SUCH AN AREA CANNOT BE AVOIDED.

THE HEATER SHALL BE LOCATED OR PROTECTED SO IT IS NOT SUBJECT TO PHYSICAL DAMAGE BY A MOVING VEHICLE.

WARNING

FLAMMABLE ITEMS, PRESSURIZED CONTAINERS OR ANY OTHER POTENTIAL FIRE HAZARDOUS ARTICLES MUST NEVER BE PLACED ON OR ADJACENT TO THE HEATER. OPEN CONTAINERS OF FLAMMABLE MATERIAL SHOULD NOT BE STORED OR USED IN THE SAME ROOM WITH THE HEATER.

THE HEATER MUST NOT BE LOCATED IN AN AREA WHERE IT WILL BE SUBJECT TO FREEZING.

LOCATE HEATER NEAR A FLOOR DRAIN. THE HEATER SHOULD BE LOCATED IN AN AREA WHERE LEAKAGE FROM **THE TANK OR CONNECTIONS WILL NOT RESULT IN DAMAGE TO THE ADJACENT AREA OR TO LOWER FLOORS OF THE STRUCTURE.**

WHEN SUCH LOCATIONS CANNOT BE AVOIDED, A SUITABLE METAL DRAIN PAN, ADEQUATELY DRAINED, SHOULD BE INSTALLED UNDER THE HEATER. Such pans should be fabricated with sides at least 2" deep, with length and width at least 2" greater than the diameter of the heater and must be piped to an adequate drain. The pan must not restrict combustion air flow.

This unit must be installed on a non-combustible surface.

LEVELING

The heater shall be installed level. If it is necessary to adjust the heater, use metal shims under the channel-type skid base.

CLEARANCES

Provide ample clearance on all sides for installation, adjustment and replacement of burner, control components and other parts.

MINIMUM INSTALLATION CLEARANCES

TPG/TPX	TPO/TPD
FRONT - 18 Inches	FRONT - 18 Inches
BACK - 0 Inches	Back - 6 Inches
TOP - 5 Inches	Top - 12 Inches
LEFT SIDE - 0 Inches	LEFT SIDE - 6 Inches
RIGHT SIDE - 0 Inches	RIGHT SIDE - 6 Inches

NOTE: If a chimney connector is used, the minimum clearance from the top of the unit to the connector is 18 inches.

AIR REQUIREMENTS

WARNING

FOR SAFE OPERATION, AN AMPLE SUPPLY OF AIR MUST BE PROVIDED FOR PROPER COMBUSTION AND VENTILATION AIR IN ACCORDANCE WITH SECTION 5.3, AIR FOR COMBUSTION AND VENTILATION, OF THE NATIONAL FUEL GAS CODE, NFPA-54/ANSI Z223.1 OR APPLICABLE PROVISIONS OF THE LOCAL BUILDING CODES. AN INSUFFICIENT SUPPLY OF AIR WILL RESULT IN A YELLOW, LUMINOUS BURNER FLAME, CAUSING CARBONING OR SOOTING OF THE HEAT EXCHANGER AND CREATING A RISK OF ASPHYXIATION. DO NOT OBSTRUCT THE FLOW OF COMBUSTION AND VENTILATION AIR.

UNCONFINED SPACE

In buildings of conventional frame, brick or stone construction, unconfined spaces may provide adequate air for combustion.

If the unconfined space is within a building of tight construction (buildings using the following construction: weather stripping, heavy insulation, caulking, vapor barrier, etc.), air for combustion, ventilation and draft hood dilution must be obtained from outdoors or spaces freely communicating with the outdoors. The installation instructions for confined spaces in tightly constructed buildings must be followed to ensure adequate air supply.

CONFINED SPACE

When drawing combustion and dilution air from inside a conventionally constructed building to a confined space, such a space shall be provided with two permanent openings, ONE IN OR WITHIN 12 INCHES OF THE ENCLOSURE TOP AND ONE IN OR WITHIN 12 INCHES OF THE ENCLOSURE BOTTOM. Each opening shall have a free area of at least one square inch per 1000 Btu/hr of the total input of all appliances in the enclosure, but not less than 100 square inches.

If the confined space is within a building of tight construction, air for combustion, ventilation and draft dilution must be obtained from outdoors. When directly venting with the outdoors or venting with the outdoors through vertical ducts, two permanent openings, located in the aforementioned manner, shall be provided. Each opening shall have a free area of not less than one square inch per 4000 Btu/hr of the total input of all appliances in the enclosure. If horizontal ducts are used, each opening shall have a free area of not less than one square inch per 2000 Btu/hr of the total input of all appliances in the enclosure.

Where an exhaust fan is installed in the same room with the boiler, sufficient openings for air must be provided in the walls. **UNDERSIZED OPENINGS WILL CAUSE AIR TO BE DRAWN INTO THE ROOM THROUGH THE CHIMNEY OR OTHER**

UNDESIRABLE OPENINGS, CAUSING POOR COMBUSTION. SOOTING MAY RESULT WITH AN INCREASED RISK OF ASPHYXIATION.

THERMAL EXPANSION (CLOSED SYSTEM)

Thermal expansion occurs in any hot water system when system water is heated or "recovered" during periods of non-use.

If the system is operated in an "open" condition such as being connected directly to the city main, the volume of expanded water generated during the recovery periods can be dissipated back through the "open" connection to the city main so pressure cannot increase.

However, once a back flow preventer is installed to isolate system water from the public supply; or a pressure reducing valve is installed to protect a water meter; or any device preventing flow back into the cold water supply, the "open" condition becomes "closed". During periods of temperature recovery and no usage, water expands and the pressure increases until a relief valve opens spilling hot water.

A relief valve opening on pressure will flow small amounts of water, whereas relieving on temperature releases large amounts of water. Consult the section under "High Water Temperature" to determine the cause of the relief valve to open due to temperature.

Since the water is not compressible, some provision must be made for THERMAL EXPANSION to protect the system from excessive pressures. Two options are:

1. Install an expansion tank properly and adequately sized for the expanding volume of water.
2. Install a pressure relief valve in the cold water supply line having a setting of at least 10lbs. below the system working pressure, located at or near a suitable drain. This valve will open at each heat cycle when there is no hot water demand on the system.

Service problems or parts failure due to excessive pressure are NOT covered under warranty.

The pressure and temperature relief valve supplied with the water heater IS NOT considered to be protection against thermal expansion.

VENTING



WARNING

THE INSTRUCTIONS IN THIS SECTION ON VENTING MUST BE FOLLOWED TO AVOID CHOKED COMBUSTION OR RECIRCULATION OF FLUE GASES. SUCH CONDITIONS CAUSE SOOTING OR RISKS OF FIRE AND ASPHYXIATION.

Heater must be protected from freezing downdrafts during shutdown periods.

Remove all soot or other obstructions from chimney, which will retard free draft.

Venting materials used for this category 1 appliance must be in accordance with the National Fuel Gas Code and all state and local requirements.

NOTE: A NEGATIVE DRAFT MUST BE MAINTAINED IN VENT PIPING (-0.02 to -0.06).

VENT CONNECTOR

The chimney vent connector diameter should be the same size as the heater flue outlet, see table 1. A minimum rise of 1/4" per foot of horizontal connector length must be maintained between the heater and chimney opening, fig. 2. The connector length should be kept as short as possible.

TABLE 1

TPG/TPX/TPO/TPD INPUT (KBTUh)	FLUE OUTLET (INCHES)
140, 199	5
255, 270, 300	6
400	7
540, 600	8
720, 800, 1000	10
1250, 1500	12
1750, 2000	14
2250, 2500	16

BAROMETRIC DRAFT CONTROL ASSEMBLY

A double-acting barometric draft control assembly is provided with each unit. This assembly must be attached to the heater as shown in figure 2. The direction in which the outlet to the draft control assembly faces is arbitrary. This assembly must be fitted to the jacket cover such that it is plumb and level to the ground. Fasten the draft control assembly to the top cover using sheet metal screws at three locations, or more, as required.

Refer to the instructions provided with the barometric damper for complete installation requirements.

Dampers or other obstructions must not be installed between the heater and the barometric draft control assembly.

Barometric draft control counterweights can be adjusted for installation conditions by an authorized State Start-Up Agent. Any readjustment must be by authorized State Start-Up agent.

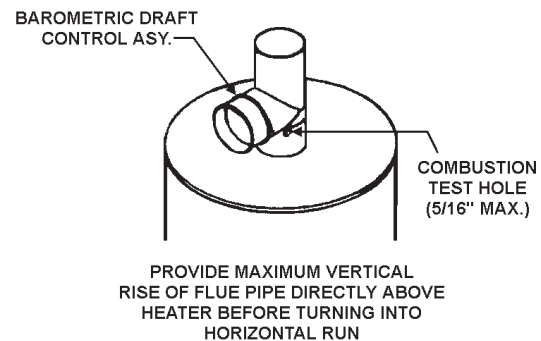

PROPER DRAFT CONTROLLER AND VENT PIPE INSTALLATION - FIGURE 2

VENT CONNECTION

Vent connections must be made to an adequate stack or chimney. Refer to the National Fuel Gas Code or to the vent pipe manufacturer's gas vent and chimney sizing table to properly design and size the venting system. Refer to Table 2 for the vent pipe size required for installation to the barometric draft control assembly outlet.

TABLE 2

CAPACITY OF PIPE - NATURAL GAS IN CUBIC FEET PER HOUR Maximum Based Upon Pressure Drop of 0.3" w.c. and Specific Gravity of 0.60 and Maximum Gas Pressure of .5 psig.							
Pipe Length In Feet	Pipe Size - Inches (IPS)						
	1	1 1/4	1 1/2	2	2 1/2	3	4
10	520	1050	1600	3050	4800	8500	17500
20	350	730	1100	2100	3300	5900	12000
30	285	590	890	1650	2700	4700	9700
40	245	500	760	1450	2300	4100	8300
50	215	440	670	1270	2000	3600	7400
60	195	400	610	1150	1850	3250	6800
70	180	370	560	1050	1700	3000	6200
80	170	350	530	990	1600	2800	5800
90	160	320	490	930	1500	2600	5400
100	150	305	460	870	1400	2500	5100
125	130	275	410	780	1250	2200	4500
150	120	250	380	710	1130	2000	4100
175	110	225	350	650	1050	1850	3800
200	100	210	320	610	980	1700	3500

NOTE: Use Multiplier at right for other specific gravities and pressure drops.

CORRECTION FACTORS			
Specific Gravity Other than 0.60		Pressure Drop Other than 0.3	
Specific Gravity	Multiplier	Pressure Drop	Multiplier
0.50	1.10	0.1	0.577
0.60	1.00	0.2	0.815
0.70	0.926	0.3	1.00
0.80	0.867	0.4	1.16
0.90	0.817	0.6	1.42
1.00	0.775	0.8	1.64
Propane - Air		1.0	1.83
1.10	0.740	2.0	2.58
Propane		3.0	3.16
1.55	0.622	4.0	3.65
		6.0	4.47
		8.0	5.15

Where an existing chimney or vent is to be used, be sure that the chimney or vent has adequate capacity for the number and sizes of gas appliances being vented through it. Inspect the chimney or vent and remove all soot or other obstructions, which will retard free draft.

Vent piping making horizontal runs must have a minimum upward slope toward the chimney or vent of 1/4" per foot. Vent pipe length should be kept as short as possible. Be sure that the vent pipe does not extend beyond the inside wall of a chimney.

In venting systems, where a continuous or intermittent back (positive) draft is found to exist, the cause must be determined and corrected. In some cases, a special vent cap may be required.

WATER LINE CONNECTIONS

The water heater may be installed by itself, or with a separate storage tank, on both single and two-temperature systems. When used with a separate storage tank, the circulation may be either by gravity or by means of a circulating pump.

SYSTEM CONNECTIONS

The system installation must conform to these instructions and to the local code authority having jurisdiction. Good practice requires that all heavy piping be supported.

THERMOMETERS (Not supplied)

Thermometers should be obtained and field installed as shown in the installation diagrams.

Thermometers are installed in the system as a means of detecting the temperature of the outlet water.

RELIEF VALVE

This water heater has been provided with an ASME rated pressure and temperature relief valve.

In addition to the appliance relief valve, each remote storage tank, which may be used in conjunction with this appliance, shall also be installed with a properly sized, rated and approved temperature (ANSI) and pressure (ASME) relief valve(s).

! WARNING

THE PURPOSE OF A RELIEF VALVE IS TO AVOID EXCESSIVE PRESSURE OR TEMPERATURE INTO THE STEAM RANGE, WHICH MAY CAUSE SCALDING AT FIXTURES, TANK EXPLOSIONS, SYSTEM OR HEATER DAMAGE. NO VALVE IS TO BE PLACED BETWEEN THE RELIEF VALVE AND THE TANK.

A DRAIN LINE MUST BE CONNECTED TO THE RELIEF VALVE TO DIRECT DISCHARGE TO A SAFE LOCATION TO AVOID SCALDING OR WATER DAMAGE. THIS LINE MUST NOT BE REDUCED FROM THE SIZE OF THE VALVE OUTLET AND MUST NOT CONTAIN VALVES, RESTRICTIONS NOR SHOULD IT BE LOCATED IN FREEZING AREAS. DO NOT THREAD OR CAP THE END OF THIS LINE. RESTRICTED OR BLOCKED DISCHARGE WILL DEFEAT THE PURPOSE OF THE VALVE AND IS UNSAFE. DISCHARGE LINE SHALL BE INSTALLED TO ALLOW COMPLETE DRAINAGE OF BOTH THE VALVE AND LINE.

Your local code authority may have other specific relief valve requirements.

GAS PIPING

Contact your local gas service company to ensure that adequate gas service is available and to review applicable installation codes for your area.

Size the main gas line in accordance with Table 3. The figures shown are for straight lengths of pipe at 0.3 in. w.c. pressure drop, which is considered normal for low-pressure systems. Note that fittings such as elbows and tees will add to the pipe pressure drop.

Equivalent lengths of standard pipe in feet for listed fittings (add below values to Table 3).

Install vent lines from main gas regulator and (if applicable) a diaphragm gas valve. Vent line should be run to the outside of the building, terminating clear of windows or fresh air intakes. Outside terminal of vent should have a screen to prevent insects from building nests in vent pipe. The vent should terminate in a manner, which will preclude the possibility of water, snow, dirt or other matter from entering the line.

**TABLE 3
EQUIVALENT LENGTH OF FITTINGS IN FEET**

Pipe Size (IPS)	1	1.25	1.5	2	2.5	3	4
Std. Tee through side	5.5	7.5	9.0	12.0	14.0	17.0	22.0
Std. E11	2.7	3.7	4.3	5.5	6.5	8.0	12.0
45°F E11	1.2	1.6	2.0	2.5	3.0	3.7	5.0
Plug Cock	3.0	4.0	5.5	7.5	9.0	12.0	16.0

⚠ WARNING

THE HEATER IS NOT INTENDED FOR OPERATION AT HIGHER THAN 13.8" WATER COLUMN (1/2 POUND PER SQUARE INCH) SUPPLY GAS PRESSURE. HIGHER GAS PRESSURE REQUIRES SUPPLEMENTAL REDUCING SERVICE REGULATION. EXPOSURE TO HIGHER GAS SUPPLY PRESSURE MAY CAUSE DAMAGE TO THE GAS CONTROLS WHICH COULD RESULT IN FIRE OR EXPLOSION. IF OVERPRESSURE HAS OCCURRED SUCH AS THROUGH IMPROPER TESTING OF GAS LINES OR EMERGENCY MALFUNCTION OF THE SUPPLY SYSTEM, THE GAS VALVE MUST BE CHECKED FOR SAFE OPERATION. MAKE SURE THAT THE OUTSIDE VENTS ON THE SUPPLY REGULATORS AND THE SAFETY VENT VALVES ARE PROTECTED AGAINST BLOCKAGE. THESE ARE PARTS OF THE GAS SUPPLY SYSTEM, NOT THE HEATER. VENT BLOCKAGE MAY OCCUR DURING ICE STORMS.

IT IS IMPORTANT TO GUARD AGAINST GAS VALVE FOULING FROM CONTAMINANTS IN THE GAS WAYS. SUCH FOULING MAY CAUSE IMPROPER OPERATION, FIRE OR EXPLOSION.

IF COPPER SUPPLY LINES ARE USED THEY MUST BE INTERNALLY TINNED AND CERTIFIED FOR GAS SERVICE.

BEFORE ATTACHING THE GAS LINE, BE SURE THAT ALL GAS PIPE IS CLEANED ON THE INSIDE.

TO TRAP ANY DIRT OR FOREIGN MATERIAL IN THE GAS SUPPLY LINE, A DIRT LEG (SOMETIMES CALLED A SEDIMENT TRAP OR DRIP LEG) MUST BE INCORPORATED IN THE PIPING. THE DIRT LEG MUST BE READILY ACCESSIBLE AND NOT SUBJECT TO FREEZING CONDITIONS. INSTALL IN ACCORDANCE WITH RECOMMENDATIONS OF SERVING GAS SUPPLIERS. REFER TO THE **NATIONAL FUEL GAS CODE**.

To prevent damage, care must be taken not to apply too much torque when attaching gas supply pipes to gas valve inlet.

Apply joint compounds (pipe dope) sparingly and only to the male threads of pipe joints. Do not apply compound to the first two threads. Use compounds resistant to the action of liquefied petroleum gases.

DISCONNECT THE APPLIANCE AND ITS MANUAL GAS SHUTOFF VALVE FROM THE GAS SUPPLY PIPING SYSTEM DURING ANY SUPPLY PRESSURE TESTING EXCEEDING 1/2 PSIG. GAS SUPPLY LINE MUST BE CAPPED WHEN DISCONNECTED FROM THE HEATER. FOR TEST PRESSURES OF 1/2 PSIG OR LESS, THE APPLIANCE NEED NOT BE DISCONNECTED, BUT MUST BE ISOLATED FROM THE SUPPLY PRESSURE TEST BY CLOSING THE MANUAL GAS SHUTOFF VALVE.

BEFORE PLACING THE HEATER IN OPERATION, CHECK FOR GAS LEAKAGE. USE SOAP AND WATER SOLUTION OR OTHER MATERIAL ACCEPTABLE FOR THE PURPOSE OF LOCATING GAS LEAKS. DO NOT USE MATCHES, CANDLES, FLAME OR OTHER SOURCES OF IGNITION FOR THIS PURPOSE.

PURGING

Gas line purging is required with new piping or systems in which air has entered.

⚠ CAUTION

PURGING SHOULD BE PERFORMED BY PERSONS EXPERIENCED IN THIS TYPE GAS SERVICE. TO AVOID RISK OF FIRE OR EXPLOSION, PURGE DISCHARGE MUST NOT ENTER CONFINED AREAS OR SPACES WHERE IGNITION CAN OCCUR. THE AREA MUST BE WELL VENTILATED AND ALL SOURCES OF IGNITION MUST BE INACTIVATED OR REMOVED.

GAS METER SIZE – CITY GASES ONLY

Be sure that the gas meter has sufficient capacity to supply the full rated gas input of the water heater as well as the requirements of all other gas fired equipment supplied by the meter. If gas meter is too small, request the gas company to install a meter having adequate capacity.

GAS PRESSURE REGULATOR

DO NOT SUBJECT COMBINATION GAS VALVE TO INLET GAS PRESSURE OF MORE THAN 14 I.W.C. A SERVICE REGULATOR IS NECESSARY IF HIGH GAS PRESSURES ARE ENCOUNTERED.

The gas pressure regulator vent line must be vented to the outside of the building.

POWER BURNER

For information relating to the power burner supplied with this water heater, refer to the power burner manual provided.

LIFTING LUGS

This water heater is supplied with lifting lugs. Prior to lifting, insure that the lugs are threaded into their receptacles as tight as possible.

These lugs may be removed after installation. Sheet metal covers are provided to cover the receptacle openings.

WIRING

The rating plate provides the electrical information needed to size the water heater branch supply circuit.

Typical water heater electrical diagrams are provided in this manual (pages 9 and 10). The actual diagram, corresponding to each water heater, is provided with each water heater, and may differ from the diagrams shown in this manual.

The TPG unit burner is wired to the water heater control compartment as shown in the following diagram. The electrical service should be connected to the N & L Terminals located in the control compartment. Ground from control compartment to suitable ground.

All electrical work must be installed in accordance with the National Electrical Code (latest version) and local requirements. **AN ELECTRICAL GROUND IS REQUIRED TO REDUCE THE RISK OF ELECTRICAL SHOCK. DO NOT ENERGIZE THE BRANCH CIRCUIT BEFORE THE HEATER TANK IS FILLED WITH WATER.**

TYPICAL WIRE DIAGRAM
TPG, 270 - 2,500 KBTUH
TPO, 800 - 2,500 KBTUH
TPD, 400 - 2,500 KBTUH

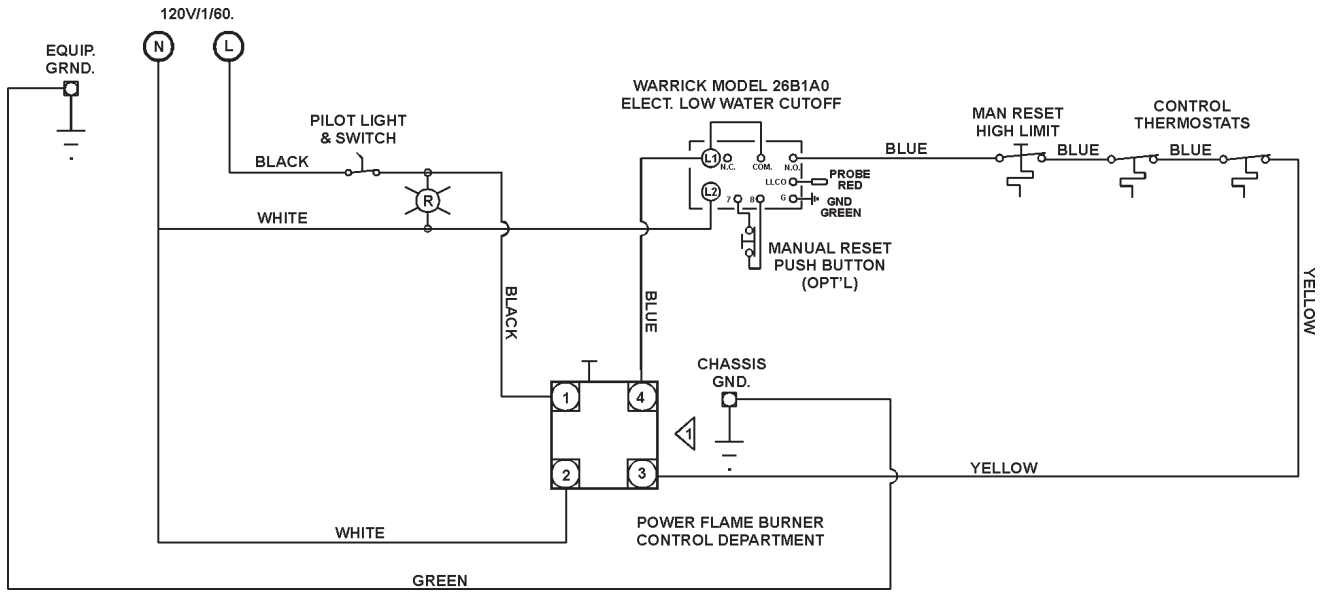

TYPICAL WIRE DIAGRAM
TPG, 140 - 255 KBTUH

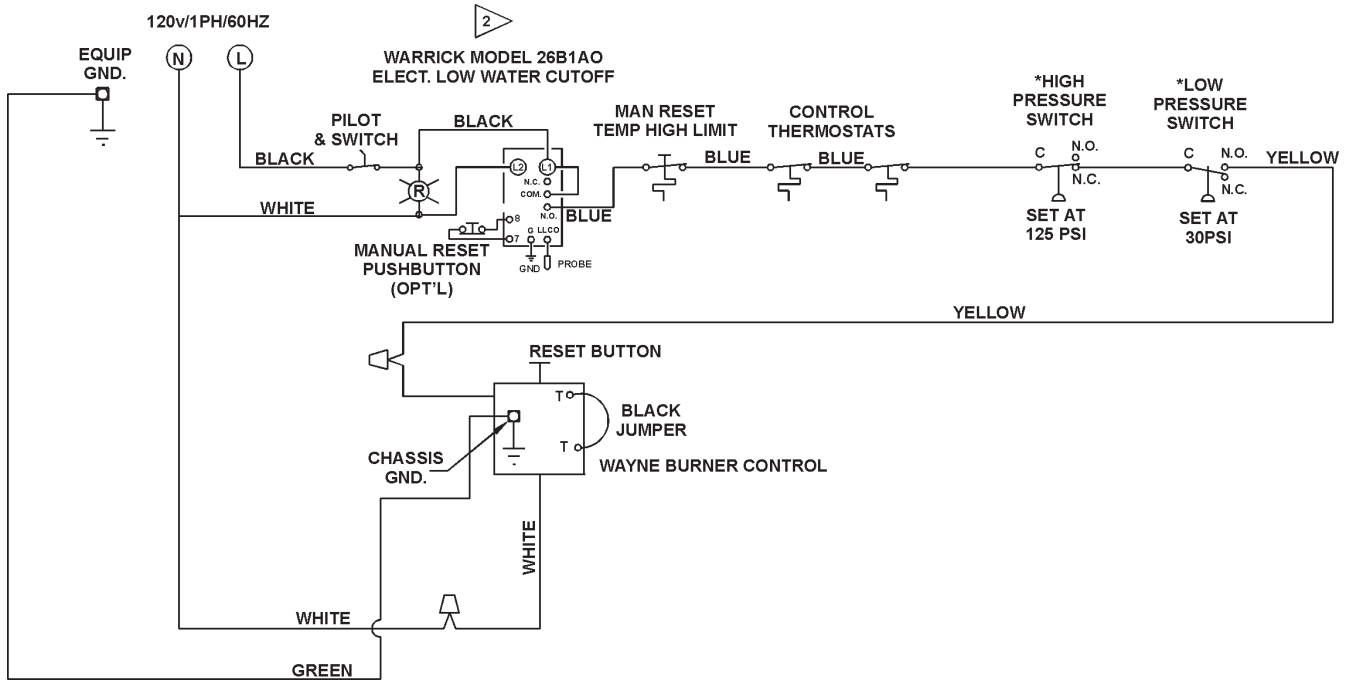

TYPICAL WIRE DIAGRAM TPD, 140 - 300 KBTUH

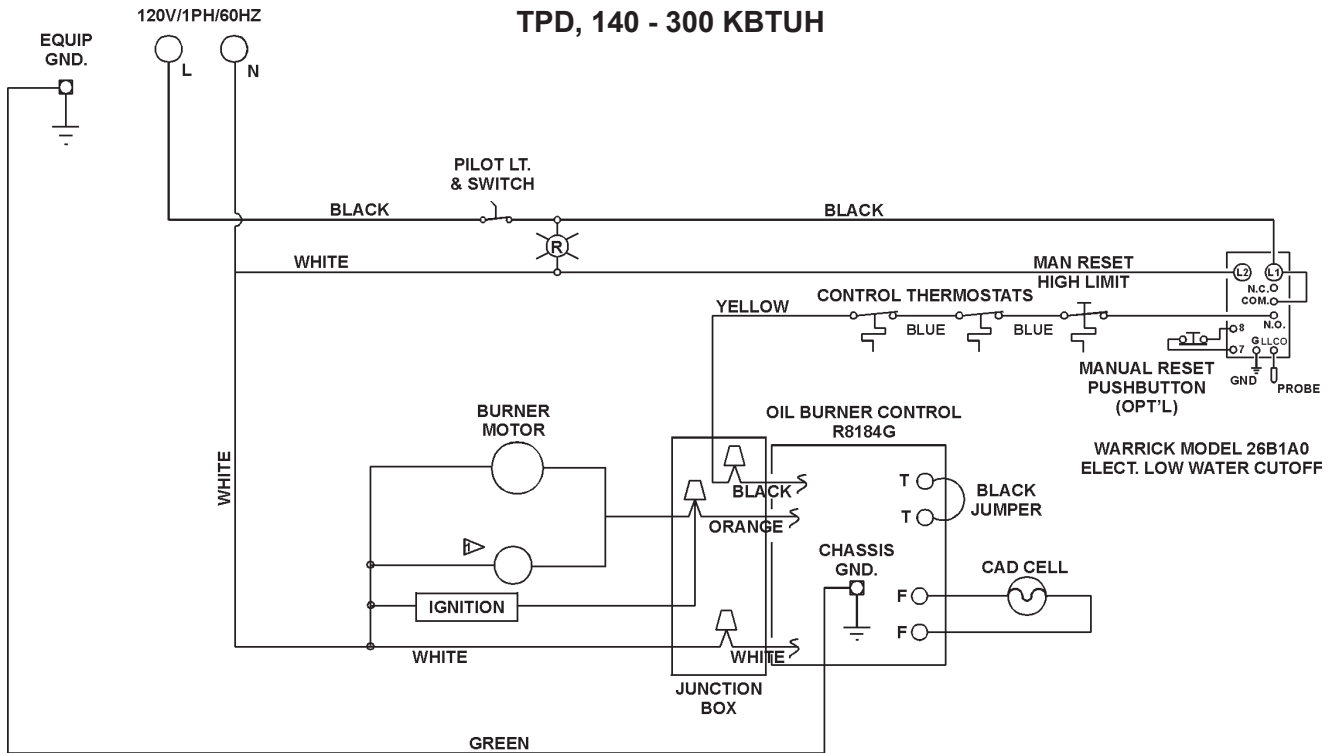

TYPICAL WIRE DIAGRAM TPO, 140 - 720 KBTUH

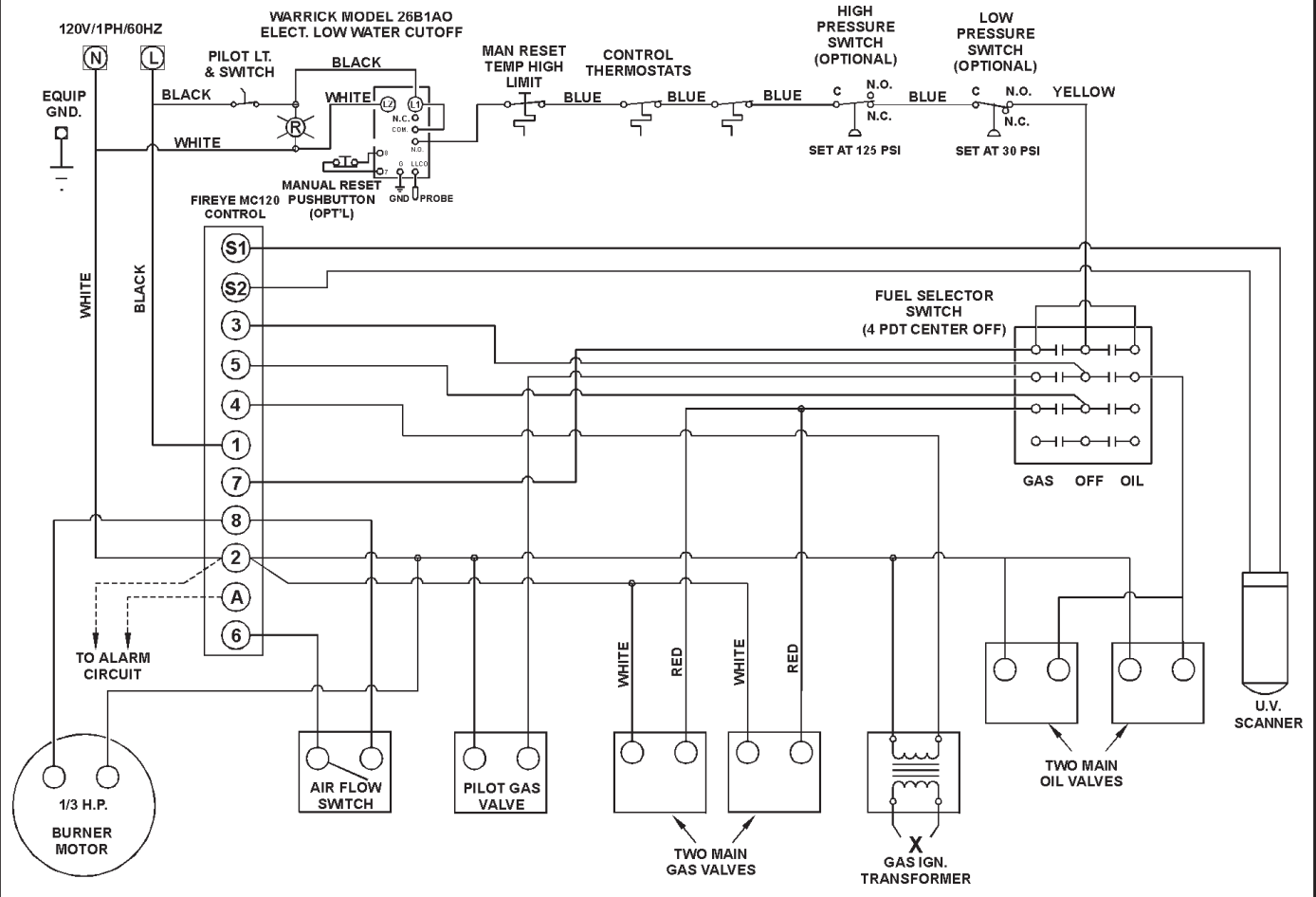

TWO UNIT MANIFOLD INSTALLATION

Assure water flow balance of all units. Without this balance, the full water heating and storage potential of the system cannot be achieved. Otherwise, the units with the higher water flow may have a shortened life.

Dimensions shown are for minimum space occupied by complete assemblies. Service space in front of units must be included.

MODEL	MANIFOLD SIZE
TPX/TPG/TPO/TPD - 140	2"
TPX/TPG/TPO/TPD - 200	2 1/2"
TPX/TPG/TPO/TPD - 300	2 1/2"
TPX/TPG/TPO/TPD - 400	3"
TPX/TPG/TPO/TPD - 600	3"

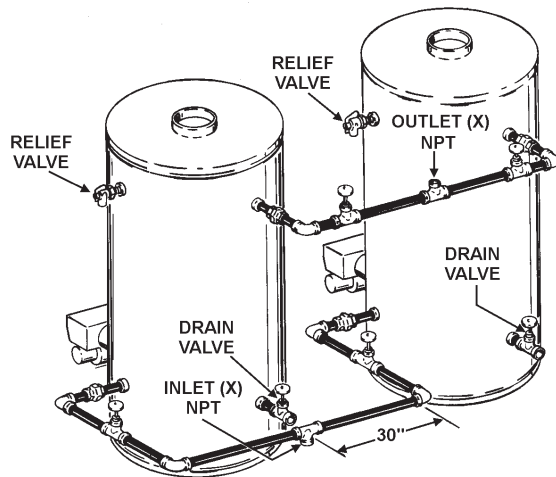

OPERATION

IMPORTANT

AUTHORIZED START-UP REQUIRED. Start-up by a State Authorized TPG/TPX/TPO/TPD Start-Up Agent is required on the models covered in this manual. Start-up and Operation of the units covered by this manual by other than a State Authorized TPG/TPX/TPO/TPD Start-Up Agent will void the warranty.

If you have not already done so, contact your local State Sales Representative or Authorized TPG/TPX/TPO/TPD Start-Up Agent and set-up a date for the start-up service.

The Authorized Start-Up Agent will when they come out to start-up the unit(s) complete one of the following forms for each unit you have and submit it to State Industries to activate your warranty:

Start-Up Form No.	Covering Models
09063511	TPG Models, 140 - 255 kBTUH
09063510	TPG Models, 270 - 2500 kBTUH
09063512	TPD Models, 140 - 2500 kBTUH
09063514	TPO Models, 140 - 2500 kBTUH
09063515	TPX Models, 400 - 2000 kBTUH

The time to ask any questions you may have about your unit is when the State Authorized TPG/TPO/TPD Start-Up Agent is there. Please do not hesitate to ask the agent any questions which you may have regarding the units start-up, operation or maintenance.

A MAINTENANCE section is included at the rear of this manual. Any service required should be performed by an Authorized State Service Agent.

GENERAL

NEVER OPERATE THE HEATER WITHOUT FIRST BEING CERTAIN IT IS FILLED WITH WATER AND A TEMPERATURE AND PRESSURE RELIEF VALVE IS INSTALLED IN THE RELIEF VALVE OPENING OF THE HEATER.



CAUTION
Before proceeding with the operation of the unit make sure the water heater and system are filled with water and all air is expelled.

FILLING

1. Close the heater drain valve by turning handle clockwise.
2. Open a nearby hot water faucet to permit the air in the system to escape.
3. Fully open the cold water inlet pipe valve allowing the heater and piping to be filled.
4. Close the hot water faucet as water starts to flow.
5. The heater is ready to be operated.

COMBUSTION AIR REQUIREMENTS AND SERVICE RECOMMENDATIONS

1. In order to fire correctly, the burner requires an adequate supply of combustion air. Ventilation to the boiler room should be provided on the basis of one square inch of free air opening for each 1000 BTU/HR input. This excludes the requirements for any other fired equipment in the room. The boiler room should not become excessively hot and under no circumstances should be under negative pressure.
2. The burner must be set up initially and serviced at regular intervals (suggested semi-annually) by a trained serviceman using the proper instruments. During this semi-annual service, primary safety devices should be tested under operating conditions. Failure to routinely test primary safety devices may cause hazards. Suggested test procedures are listed in the following paragraphs. Failure to maintain the correct burner settings may result in inefficient gas consumption, premature wear of burner components, or explosion hazard.
3. The correct test instruments are:
 - CO₂ indicator or O₂ analyzer
 - CO indicator
 - Stack thermometer
 - Draft gauge or inclined manometer
 - U-tube manometer or calibrated 0-10" and 0-35" w.c. pressure gauge
 - Combination volt/ammeter.

Suggested safety device test procedures are:

- A. While heater is operating, turn valve, main burner and pilot gas line manual gas cocks to the OFF position. Burner should shutdown within 3-4 seconds and lockout on flame failure, requiring reset of the flame safeguard device.
- B. While heater is operating, lower the setting of each of (2) operating thermostats (one at a time). During this setting change, the burner should shutdown when the called for temperature is less than the temperature indicated on the thermometer. Restore the settings to original values and burner should restart.

Should any of the above operating test fail, replace the involved component.

MAINTENANCE

GENERAL

Water heater maintenance includes periodic tank flushing and cleaning, and removal of lime scale. The power burner should be inspected and adjusted to maintain proper combustion. Refer to the following table. A periodic inspection of the venting system should be made. Where used, the water heating system circulating pump should be oiled.

KEEP APPLIANCE AREA CLEAR AND FREE FROM COMBUSTIBLE MATERIALS, GASOLINE AND OTHER FLAMMABLE VAPORS AND LIQUIDS.

FLUSHING

1. Turn off the heater electrical disconnect switch.
 - For convenience, the switch on the outside of the control compartment can be used.
2. Open the drain valve and allow water to flow until it runs clean.
3. Close the drain valve when finished flushing.
4. Turn on the heater electrical disconnect switch.

MAINTENANCE SCHEDULE

Component	Operation	Interval	Required
Tank	Flushing	Monthly	
	Sediment Removal	Semi-Annually	
	Lime Scale Removal	As Required	UN•LIME® Delimer
Relief Valve	Inspect	Semi-Annually	
Power Burner Motor(1)	Inspect	Quarterly	SAE No. 20 non-detergent motor oil
Power Burner and Ignition Device(2)	Inspection	Semi-Annually	Combustion test kit & test specifications
Main Burner	Check Flame	Annually	
Flue Baffle Pipe(3)	Cleaning	As Required	Wire Brush
Vent System and Barometric Damper	Inspect	Semi-Annually	Draft Gauge

(1) If furnished with oiling provisions

(2) If flange gasket is damaged, it must be repaired.

(3) TPO and TPD Only.

DRAINING

The heater must be drained if it is to be shut down or exposed to freezing temperatures. Maintenance and service procedures may also require draining the heater.

1. Turn off the heater electrical disconnect switch.
2. Close the cold water inlet valve to heater.
3. Open a nearby hot water faucet to vent the system.
4. Open the heater drain valve.
5. If the heater is being drained for an extended shutdown, it is suggested the drain valve be left open during this period.

- Follow **FILLING** instructions when restoring hot water service

SEDIMENT REMOVAL

Waterborne impurities consist of fine particles of soil and sand which settle out and form a layer of sediment on the bottom of the tank.

For convenience, sediment removal and lime scale removal should be performed at the same time.

LIME SCALE REMOVAL

The amount of calcium (lime) released from water is indirect proportion to water temperature and usage. The higher the water temperature or water usage, the more lime deposits are dropped out of the water. This is the lime scale which forms in pipes, heaters and on cooking utensils.

Lime accumulation not only reduces the life of the equipment but also reduces efficiency of the heater and increases fuel consumption.

POUNDS OF LIME DEPOSITED VS. TEMPERATURE AND WATER USAGE

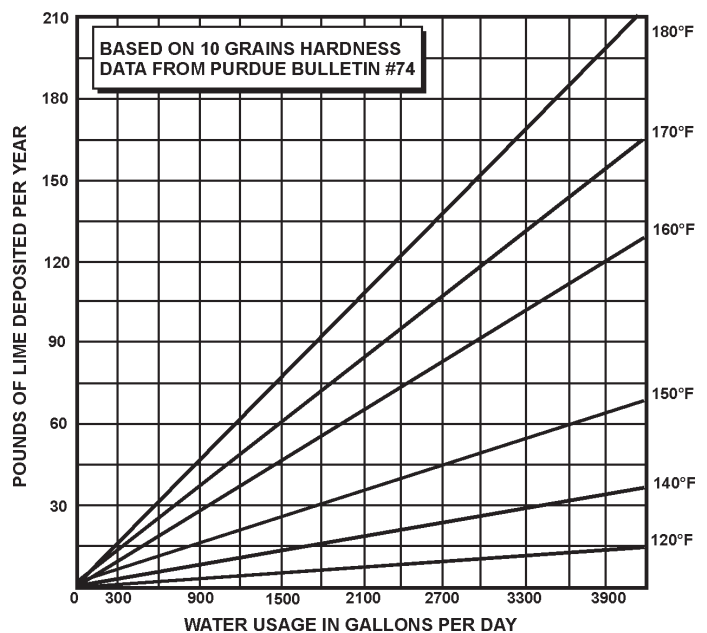

The usage of water softening equipment greatly reduces the hardness of the water. However, this equipment does not always remove all of the hardness (lime). For this reason it is recommended that a regular schedule for deliming be maintained.

The depth of lime build-up should be measured periodically. Heaters will have about 3" of lime build-up when the level of lime has reached the bottom of the cleanout opening or about 1" of lime build-up if it has reached the drain valve opening. A schedule for deliming should be set-up; based on the amount of time it would take for a 1" build-up of lime.

Example 1 = Initial inspection, after 1 year, shows 1/2" of lime accumulation. Therefore, the heater can be delimed once a year.

Example 2 = Initial inspection, after 1 year, shows 2" of lime accumulation. Therefore, the heater should be delimed every 3 months.

Following are the instructions for performing some of the recommended maintenance. Power burner inspection and adjustment should be performed by a competent technician.

Heater failure due to excessive lime build-up voids the warranty.

Sediment and lime scale removal may be accomplished through the cleanout opening furnished on the heater. The heater must be drained, see DRAINING, before removing cleanout cover on tank.

To dissolve and remove the more stubborn mineral deposits, UN•LIME Professional Delimer should be used.

UN-LIME Delimer is an easy to handle patented food grade acid formulated specifically for lime scale removal from all types of water using equipment. Available in 1 gallon (part no. 4763) and 5 gallon (part no. 4813) sizes. Hydrochloric acids are not recommended for use on glass-lined tanks.

Form no. 4800, entitled, "Why, When and How", describes tank cleaning methods and materials. UN•LIME and the booklet may be obtained through your State dealer or distributor.

To clean heater through cleanout opening, proceed as follows:

1. Turn off water inlet valve, the heater electrical disconnect switch and open drain valve.
2. Remove outer cover plate from lower side of heater jacket.
3. Remove plug from cleanout opening.
 - Place a short pipe nipple into the tank to extend beyond the heater jacket.
4. Remove lime, scale and sediment using care not to damage the glass coatings inside the tank.
5. Remove the nipple.
6. Replace cleanout plug.
7. Follow filling instructions when restoring hot water service..
8. Check for water leakage and correct as necessary.
9. Replace outer jacket cover plate.

RELIEF VALVE

At least twice a year, the temperature and pressure relief valve should be checked to ensure that it is in operating condition. To

check the relief valve, lift the lever at the end of the valve several times. The valve should seat properly and operate freely.

CAUTION

BEFORE MANUALLY OPERATING THE VALVE, MAKE SURE THAT A DRAIN LINE HAS BEEN ATTACHED TO THE VALVE TO DIRECT THE DISCHARGE TO AN OPEN DRAIN. FAILURE TO TAKE THIS PRECAUTION COULD MEAN CONTACT WITH EXTREMELY HOT WATER PASSING OUT OF THE VALVE DURING THIS CHECKING OPERATION.

If the temperature and pressure relief valve on the heater discharges periodically or continuously, it may be due to the thermal expansion of water in a closed water supply system, or it may be due to a faulty relief valve.

Thermal expansion is the normal response of water when it is heated. In a closed system, thermal expansion will cause the system pressure to increase until the relief valve actuation pressure is equaled. Then, the relief valve will open, allowing some water to escape slightly lowering the pressure. (See THERMAL EXPANSION Section of pages 5 and 6).

Contact your water supplier or local plumbing inspector on how to control this situation.

ABOVE ALL, DO NOT PLUG THE TEMPERATURE AND PRESSURE RELIEF VALVE. THIS IS NOT A SOLUTION AND CAN CREATE A HAZARDOUS SITUATION.

POWER BURNER

KEEP THE AREA AROUND THE BURNER CLEAR AND FREE OF COMBUSTIBLE MATERIALS, GASOLINE OR OTHER FLAMMABLE LIQUIDS OR VAPORS. DO NOT OBSTRUCT BURNER AIR OPENINGS OR VENTILATION GRILLES FOR COMBUSTION AIR. REMOVE LINT ACCUMULATION FROM AIR INTAKE GRILL.

At least annually, contact a qualified service agency for burner cleaning and other routine maintenance.

CLEANING FLUES-TPO & TPD ONLY

The following describes how to gain access to the tank flues for cleaning if necessary.

1. Turn off the heater electrical disconnect switch.
 - The switch on the outside of the control compartment may be used.
2. Remove the vent connector from on top the heater.
3. Remove the jacket top from the heater by taking out the screws and lifting it off.
 - The insulating pad should then be lifted out.
4. Take out the screws holding the flue gas collector top to the tank and lift off.
5. The flue baffles may now be removed by lifting out.
 - The flue baffles are flexible enough to bend for removal within headroom.

- Using a wire brush, remove soot from flue passages in heater tank.

CAUTION

While cleaning tank flue passages, care must be taken that brush does not come in contact with the combustion chamber lining as damage could occur.

- If burner flue collector flange gaskets are damaged, replace.

VENT SYSTEMS

Examine the vent system every six months for obstruction and/or deterioration of vent piping. Remove any soot or obstructions and replace damaged vent piping.

BAROMETRIC DRAFT CONTROL

The heater is equipped with a double acting barometric draft control. The damper gate must pivot freely in the ring guides.

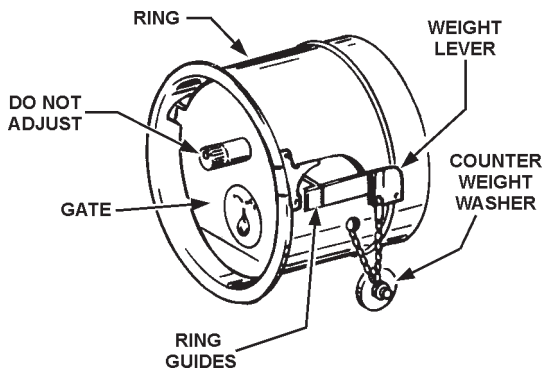

FIGURE 3

To test gate for operation, gently tap gate and observe. **DO NOT OIL.**

The red solid fuel tabs supplied with the draft regulator must be removed (See instructions supplied with Draft Regulator).

TROUBLESHOOTING

NOT ENOUGH OR NO HOT WATER

- Be certain the electrical disconnect switch serving the water heater is in the ON position.
 - The outside of the control compartment and the power burner housing also have switches.
- Check the fuses
 - The electrical disconnect switch usually contains fuses.
- The capacity of the heater may have been exceeded by a large demand for hot water.
 - Large demands require a recovery period to restore water temperature.
- Colder incoming water temperature will lengthen the time required to heat water to the desired temperature.

- If the heater was installed when incoming water temperature was warm, colder water creates the effect of less hot water.
- Look for hot water wastage and leaking or open hot water faucets.
 - Sediment or lime scale may be affecting water heater operation. Refer to MAINTENANCE for details.
 - Heater or burner may be dirty.
 - Clean all heater flue pipes and flue connector, see MAINTENANCE.
 - Have burner properly cleaned and readjusted.
 - Burner may not be firing at proper rate.
 - Check gas pressure, see burner manufacturer's instruction manual.
 - Burner fan wheel may be dirty.
 - Draft regulator may be stuck.
 - Check to see if vane swings freely. Clean, if vane is stuck.
 - Reset button or burner flame safeguard primary control has operated.

WATER IS TOO HOT

- Water temperature control may be set too high.
- If lowering the control setting does not reduce the water temperature, contact your dealer.

WATER HEATER MAKES NOISE

- Sediment or lime scale accumulations cause noises when the heater is operating.
 - The sounds are normal, however, the tank bottom should be cleaned. Refer to MAINTENANCE for details.
- Some of the electrical components of the water heater make sounds, which are normal.
 - Contacts click or snap as the heater starts and stops.
 - Transformers often hum.

WATER LEAKAGE IS SUSPECTED

- Check to see if the water heater drain valve is tightly closed. Also check the cleanout-opening plug for leakage.
- The apparent leakage may be condensation, which forms on cool surfaces of the heater and piping.
- If the outlet of the relief valve is leaking it may represent:
 - Excessive water pressure.
 - Excessive water temperature.
 - Faulty relief valve.

Excessive water pressure is the most common cause of relief valve leakage. It is often caused by a "closed system". If a check valve is in the inlet system it will not permit the expanded hot water volume to equalize pressure with the main. The relief valve must release this water or the water heater or plumbing system will be damaged.

When such a condition is encountered, local codes or inspection agency should be consulted to determine which system is acceptable in your area. These may consist of:

- Installation of a second relief valve with lower setting than the primary relief valve.
- An expansion tank of suitable size and pressure rating and

provision to avoid water logging.

REPLACEMENT PARTS

Replacement parts may be ordered through authorized servicers or distributors, refer to your local Yellow Pages for where to call or contact State Water Heaters, 500 Lindahl Parkway, Ashland City, TN 37015. When ordering parts, be sure to state the quantity, part number and description of the item including the complete model and serial number as it appears on the product. Refer to the parts list for more information.

For additional troubleshooting information, refer to the power burner manual.

Model TPG/TPX/TPO/TPD Limited Warranty

CERTIFIED FACTORY START - UP REQUIRED

To activate your warranty, contact your local sales representative or Authorized Start-up Agent to arrange for a FREE Certified Start-up.

State Water Heaters, the warrantor, extends the following LIMITED WARRANTY to the owner of this water heater.

1. THE TANK

If the glass lined tank in this water heater shall prove upon examination by the warrantor to have leaked due to natural corrosion from potable water therein, during the first THREE years after initial installation, the warrantor will at its option, provide a replacement State water heater of equivalent size and current model, less burner and controls. Some government agencies are requiring energy efficient standards for water heaters. In the event regulations prohibit sale of a model of equivalent size and construction, State Water Heaters will provide a model which complies with the regulations of your area, in which case the consumer will be charged the difference in price between the like replacement and the energy efficient model required. The warranty on the replacement water heater will be limited to the unexpired term of the original warranty.

2. ALL OTHER PARTS

If within ONE year after initial installation of this water heater, any part or portion shall prove upon examination by the warrantor to be defective in material or workmanship, the warrantor will repair such part or portion at its option.

3. CONDITIONS AND EXCEPTIONS

This warranty shall apply only if a certified factory start-up was performed and if the water heater is installed in accordance with local plumbing and building codes, ordinances and regulations, the printed instructions provided with it and good industry practices. In addition, a temperature and pressure relief valve, approved by the American Society of Mechanical Engineers, must have been installed.

a) This warranty shall apply only when the heater is:

- (1) owned by the original purchaser.
- (2) sized in accordance with proper sizing techniques for commercial water heaters.
- (3) bearing a rating plate which has not been altered, defaced or removed except as required by the warrantor.
- (4) used in an open system, or in a closed system with a properly sized and installed thermal expansion tank.
- (5) fired with the fuel for which it was factory built.
- (6) fired at the factory rated input.
- (7) used at temperatures not exceeding the maximum setting of its thermostat;
- (8) used at water pressure not exceeding the working pressure shown on the water heater;
- (9) used when operated free from the damaging effects of uncontrolled water hammer;
- (10) used when filled with potable water, free to circulate at all times and the tank free of damaging water sediment or scaled deposits;
- (11) in a non-corrosive and not-contaminated atmosphere;
- (12) in its original installation location;
- (13) used with factory approved anode(s) installed;
- (14) in the United States, its territories or possessions, and Canada.

b) Any accident to the water heater, any misuse, abuse (including freezing) or alteration of it, any operation of it in a modified form, or any attempt to repair tank leaks will void this warranty.

c) This warranty is void if a device acting as a backflow prevention device (check valves etc.) is installed in the cold water supply the heater is connected to, unless an effective method of controlling thermal expansion is also installed at the heater(s) and operational at all times. The relief valve installed on the heater is not an acceptable method.

4. SERVICE AND REPAIR EXPENSES

Under the limited warranty the warrantor will provide only a replacement water heater or part thereof. The owner is responsible for all other costs. Such costs may include but are not limited to:

- a) Labor charges for service removal, repair or reinstallation of the water heater or any component part;
- b) Shipping, delivery, handling, and administrative charges for forwarding the new heater or replacement part from the nearest distributor and returning the claimed defective heater or part to such distributor.
- c) All cost necessary or incidental for any material and/or permits required for installation of the replacement heater or part.

5. LIMITATIONS ON IMPLIED WARRANTIES

Implied warranties, including the warranty of merchantability imposed on the sale of this heater under state law are limited to one (1) year duration for the heater or any of its parts. Some states do not allow limitation on how long an implied warranty lasts, so the above limitation may not apply to you.

6. CLAIM PROCEDURE

Any claim under the warranty should be initiated with the dealer who sold the heater, or with any other dealer handling the warrantor's products. If this is not practicable, the owner should contact:

State Water Heaters
500 Lindahl Parkway
Ashland City, TN 37015

- a) The warrantor will only honor replacement with identical or similar water heater or parts thereof, which are manufactured or distributed by the warrantor.
- b) Dealer replacements are made subject to in-warranty validation by warrantor.

7. DISCLAIMERS

NO OTHER EXPRESS WARRANTY HAS BEEN OR WILL BE MADE IN BEHALF OF THE WARRANTOR WITH RESPECT TO THE HEATER OR THE INSTALLATION, OPERATION, REPAIR OR REPLACEMENT OF THE HEATER. THE WARRANTOR SHALL NOT BE RESPONSIBLE FOR WATER DAMAGE, LOSS OF USE OF THE UNIT, INCONVENIENCE, LOSS OR DAMAGE TO PERSONAL PROPERTY OR OTHER CONSEQUENTIAL DAMAGE. THE WARRANTOR SHALL NOT BE LIABLE BY VIRTUE OF THIS WARRANTY OR OTHERWISE FOR DAMAGE TO ANY PERSONS OR PROPERTY, WHETHER DIRECT OR INDIRECT, AND WHETHER ARISING IN CONTRACT OR IN TORT.

- a) Some states do not allow the exclusion or limitation of the incidental or consequential damage, so the above limitations or exclusions may not apply to you
- b) This warranty gives you specific legal rights, and you may also have other rights, which may vary, from state to state.

Fill in the following for your own reference. KEEP IT. Registration is not a condition of warranty. The model and serial number are found on the heater's rating plate.

Model No. _____ Serial No. _____ Date Installed _____

Dealer's Name _____

Dealer's Address _____ Phone Number _____

City and State _____ Zip _____

KEEP THIS WARRANTY POSTED ADJACENT TO THE HEATER FOR FUTURE REFERENCE.

Free Manuals Download Website

<http://myh66.com>

<http://usermanuals.us>

<http://www.somanuals.com>

<http://www.4manuals.cc>

<http://www.manual-lib.com>

<http://www.404manual.com>

<http://www.luxmanual.com>

<http://aubethermostatmanual.com>

Golf course search by state

<http://golfingnear.com>

Email search by domain

<http://emailbydomain.com>

Auto manuals search

<http://auto.somanuals.com>

TV manuals search

<http://tv.somanuals.com>