

Operating Instructions

Safety Filters

SFC-A 40

SFC-A 50

SFC-A 65

Sterling Material Processing

5200 West Clinton Ave.

Milwaukee, WI 53223

Telephone: (414) 354-0970

Fax: (414) 354-6421

www.sterlco.com

Parts and Service:

Telephone: **(800) 423-3183**

Edition: 12/98

These operating instructions are for:

Serial number: _____

Built in: _____

Date of delivery: _____

Number of delivery: _____

Date of commissioning: _____

Location: _____

Group of machines: _____

* Please fill in personally

SM3-635a

Sterling Material Processing retains all rights to change the information in these operating instructions at any time without notice.

We assume no liability for any errors or direct or indirect damage resulting in context with these operating instructions.

Copying, translation or publication in any form except for personal use of purchaser requires approval from Sterling Material Processing.

All rights reserved.

Please note that our address and phone information has changed. Please reference this page for updated contact information.



These manuals are obsolete and are provided only for their technical information, data and capacities. Portions of these manuals detailing procedures or precautions in the operation, inspection, maintenance and repair of the products may be inadequate, inaccurate, and/or incomplete and shouldn't be relied upon. Please contact the ACS Group for more current information about these manuals and their warnings and precautions.

Parts and Service Department

The ACS Customer Service Group will provide your company with genuine OEM quality parts manufactured to engineering design specifications, which will maximize your equipment's performance and efficiency. To assist in expediting your phone or fax order, please have the model and serial number of your unit when you contact us. A customer replacement parts list is included in this manual for your convenience. ACS welcomes inquiries on all your parts needs and is dedicated to providing excellent customer service.

For immediate assistance, please contact:

- North, Central and South America, 8am – 5pm CST +1 (800) 483-3919 for drying, conveying, heating and cooling and automation. For size reduction: +1 (800) 229-2919.
North America, emergencies after 5pm CST (847) 439-5855
North America email: acsuscanadacustserv@corpemail.com
- Mexico, Central & South America
Email: acslatinamericacustserv@corpemail.com
- Europe, Middle East & Africa +48 22 390 9720
Email: acseuropecustserv@corpemail.com
- India +91 21 35329112
Email: acsindiacustserv@corpemail.com
- Asia/Australia +86 512 8717 1919
Email: acsasiacustserv@corpemail.com

Sales and Contracting Department

Our products are sold by a worldwide network of independent sales representatives. Contact our Sales Department for the name of the sales representative nearest you.

Let us install your system. The Contract Department offers any or all of these services: project planning; system packages including drawings; equipment, labor, and construction materials; and union or non-union installations.

For assistance with your sales or system contracting needs please Call:

North, Central and South America +1 (262) 641-8600 or +1 (847) 273-7700 Monday–Friday, 8am–5pm CST

Europe/Middle East/Africa +48 22 390 9720

India +91 21 35329112

Asia/Australia +86 512 8717 1919

Facilities:

ACS offers facilities around the world to service you no matter where you are located. For more information, please visit us at www.acscorporate.com

United States:

ACS Schaumburg – Corporate Offices

1100 E. Woodfield Road
Suite 588
Schaumburg, IL 60173
Phone: + 1 847 273 7700
Fax: + 1 847 273 7804

ACS New Berlin – Manufacturing Facility

2900 S. 160th Street
New Berlin, WI 53151
Phone : +1 262 641 8600
Fax: + 1 262 641 8653

Asia/Australia:

ACS Suzhou

109 Xingpu Road SIP
Suzhou, China 215126
Phone: + 86 8717 1919
Fax: +86 512 8717 1916

Europe/Middle East/Africa:

ACS Warsaw

Ul. Działkowa 115
02-234 Warszawa
Phone: + 48 22 390 9720
Fax: +48 22 390 9724

India

ACS India

Gat No. 191/1, Sandbhor Complex
Mhalunge, Chakan, Tal Khed,
Dist. Pune 410501, India
Phone: +91 21 35329112
Fax: + 91 20 40147576

Table of contents

1. Safety instructions	6
1.1. Warnings and symbols	7
1.2. Explanations and information	8
1.3. For your safety	9
1.4. For the operating safety of the equipment.	12
2. Installation instructions	14
2.1. Transport	16
2.2. Installation	17
2.3. Compressed air supply	18
2.4. Electrical connection	19
3. Functioning description	21
3.1. General	22
4. Putting into operation	23
4.1. Checking the settings of the conveying control	24
4.2. Checking the line system	24
5. Maintenance	25
5.1. Maintenance intervals	27
5.2. Clean collecting container	28
5.3. Clean/replace filter cartridge	29

6. Technical data **31**
 6.1. Data sheet 32

7. Appendix **33**
 7.1. Spare parts list 34

1. Safety instructions



These safety instructions apply to all persons within the range of action of the equipment.

Please inform all persons within the range of action of the equipment of the direct and indirect hazards connected with the equipment.

These operating instructions are to be used by all persons assigned activities connected with the equipment.

Knowledge of the English language is prerequisite.

Ensure in each case that the operating personnel are familiar with the operating instructions and the function of the equipment.

1.1. Warnings and symbols

The following warnings and symbols are used in these operating instructions:



This symbol indicates danger to life! Fatal or serious injury is possible if the corresponding instructions, regulations or warnings are not observed.



This symbol indicates that serious injury is possible if the corresponding instructions, regulations or warnings are not observed.



This symbol indicates that extensive damage to equipment is possible if the corresponding instructions, regulations or warnings are not observed.



This symbol indicates information important for becoming familiar with the equipment, i.e. technical correlations.



This symbol indicates that a technical term is explained at this point.

1.2. Explanations and information

Various terms and designations are used frequently in these operating instructions to ensure clarity. Therefore please note that the terms used in the text stand for the corresponding explanations listed below.

- **Equipment**
“Equipment” can mean an individual unit, a machine or an installation.

- **Operating personnel**
The “operating personnel” are persons operating the equipment on their own responsibility or according to instructions (minimum age: 16).

- **Operator**
The “operator” of the equipment (production manager, foreman, etc.) is the person responsible for all production sequences. The operator instructs the operating personnel of what is to be done.

- **Operating instructions**
The “plant operating instructions” describe the interaction of the equipment, production sequences or methods. The plant operating instructions must be compiled by the operator of the equipment.

- **Equipment foreman**
When several operating personnel work on one machine, the “equipment foreman” coordinates the sequences. The equipment foreman must be appointed by the operator.

- **Trained personnel**
“Trained personnel” are persons who, due to their training, are authorized to carry out the required work in good practice.

1.3. For your safety

- The operating personnel of this equipment must be at least 16 years old.
- Please read these operating instructions carefully before taking into operation for the first time. Contact us should questions arise.
This avoids injury and damage to equipment!
- These operating instructions must be kept available at all times at the place of operation of the equipment. Improper operation results in danger of accidents!
- Please note that, for reasons of clarity, not all conceivable cases regarding operation or maintenance of the equipment can be covered in these operating instructions.
- Please observe all safety instructions and warnings on the equipment.
This avoids injury and damage to equipment!
- All work on the equipment is to be carried out by persons whose qualifications are specified in the pertaining chapters of the operating instructions.
Improper operation results in danger of accidents!
- The proper working clothes are to be worn during any work on the equipment.
This avoids injury!
- Compare the connected loads with those of the mains supply.
Danger of injury through electrical shock!
- When using lifting gear, please observe the pertaining regulations.
Caution: Danger of accidents!
- The local regulations and requirements pertaining to this equipment must be observed.
- Disconnect electrical components from the mains supply before work is carried out on these components. Caution: Danger to life through electrical shock!

- Do not modify, add other equipment or change the design of the equipment without the approval of the manufacturer. Caution: Danger of accidents!
- Compile detailed operating instructions based on these Operating instructions for the sequence of procedures to be carried out on this equipment. Improper operation results in danger of accidents!
- Appoint an equipment foreman to be responsible for the equipment.
- Ensure that the operating personnel are provided detailed instruction in the operation of the equipment. Improper operation results in danger of accidents!
- When the main switch is switched off for reasons pertaining to safety, it must be secured against unauthorized activation. Caution: Danger of accidents!
- Before starting maintenance work, appoint a supervisor.
- Inform the responsible personnel before maintenance work on the system is started. Caution: Danger of accidents!
- Disconnect the equipment from mains supply before starting maintenance procedures to ensure that it cannot be switched on unintentionally. Caution: Danger of accidents!
- Repair work may be carried out by trained personnel only. Caution: Danger of accidents!
- Never operate the equipment when partially dismantled! Danger! Limbs may be caught in machinery! Electric shock!
- In case of malfunction, shut down the equipment immediately. Have malfunctions corrected immediately. Danger of accidents!
- The equipment is intended only for conveying granulated plastics and regrinds. Any other or additional use is contrary to specifications.

- This equipment is not suitable for food processing.
- Please note that sound levels exceeding 85 db(A) may in the long term damage your health. Use the appropriate ear muffs. This avoids impairment of hearing!
- Attachments not supplied by Sterling must be manufactured in accordance with safety regulation EN 294. Danger of accidents!
- All pipes, hoses and screwed connections should be checked regularly for leaks and damage. Any faults which arise should be corrected immediately.
Danger of accidents!
- Depressurise all compressed air piping before starting maintenance work.
Danger of accidents!
- The equipment may only be operated when all the associated components are properly connected up and in accordance with the relevant regulations.
- The equipment may only be used together with a conveying system.
- The safety instructions of the connected machines must be followed.

1.4. For the operating safety of the equipment

- Never change settings if the consequences are not precisely known.
- Use only original Sterling spare parts.
- Please observe the maintenance schedule.
- Keep record of all maintenance and repair work.
- Please note that electronic components may be damaged by static discharge.
- Check all electrical connections for proper fit before the equipment is taken into operation for the first time and at regular intervals.
- Never adjust sensors without exact knowledge of their function.
- Please note that the ambient temperature must not exceed 70 °C (158°F).
- The safety filter may only be used together with a conveying system.
- The safety filter requires a compressed-air supply (max. 5-6 bar (72-87 PSI) system overpressure).
- Never set a higher operating pressure than 6 bar (87 PSI) for the safety filter (system overpressure).
- Install the safety filter in the suction line right in front of the vacuum generator.
- Observe that the filter cleaning procedure is carried out while the vacuum generator is running.
- Observe the operating instructions of the conveying system.

- Check the collecting container for tightness following each cleaning procedure.
- Make sure that the one-way restrictor regulation should not be changed.
- The operating instructions of the connected machines must be followed.
- All components must be sufficiently grounded.

2. Installation instructions



These installation instructions are intended for persons with skills in electrical and mechanical areas due to their training, experience and received instructions.

Personnel using these installation instructions must be instructed in the regulations for the prevention of accidents, the operating conditions and safety regulations and their implementation.

Ensure in each case that the personnel are informed.

The installation instructions provided in the corresponding operating instructions apply for all connected equipment.

Observe safety regulations with regard to lifting gear handling

All installation work must be carried out with the equipment disconnected from electrical power and compressed air supply.



For installation work taking place at heights of over approx. 6 feet, use only ladders or similar equipment and working platforms intended for this purpose. At greater heights, the proper equipment for protection against falling must be worn.

Use only suitable lifting gear which is in proper working order and load suspension devices with sufficient carrying capacity. Do not stand or work under suspended loads!

Use suitable workshop equipment.



Install the equipment such that all parts are easily accessible; this facilitates maintenance and repair work.

2.1. Transport

The unit is delivered as a complete sub-assembly. Transport the unit on a pallet. Lift the unit only by the wall support flange (B) or by the separator container (A). Use only suitable lifting gear (e.g. hoisting crane or forklift).



Observe the carrying capacity of the lifting gear.

Observe the safety instructions for the handling of lifting gear.



Never lift the unit by the pneumatique valve.

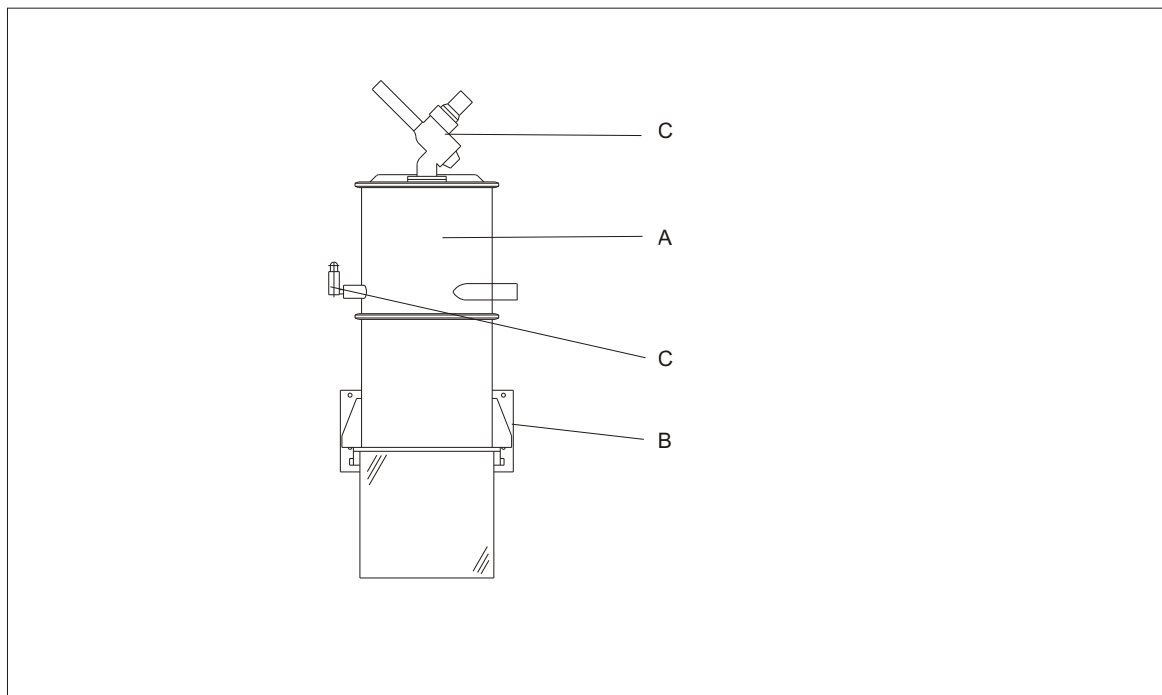

SFC-A

2.2. Installation

For installation, the wall support flange (A) is used.



Install the safety filter by means of four screws which guarantee a carrying capacity of at least 100 kg (220 lbs.).

Install the safety filter in the suction tube directly before the vacuum generator.

Connect the line to the conveyor units to the tube of the hopper loader (B) by means of a flexible hose. Screw both parts together by means of a hose clamp.

Connect the line to the vacuum generator to the tube of the compressed-air valve (C) by means of a flexible hose. Screw both parts together by means of a hose clamp.

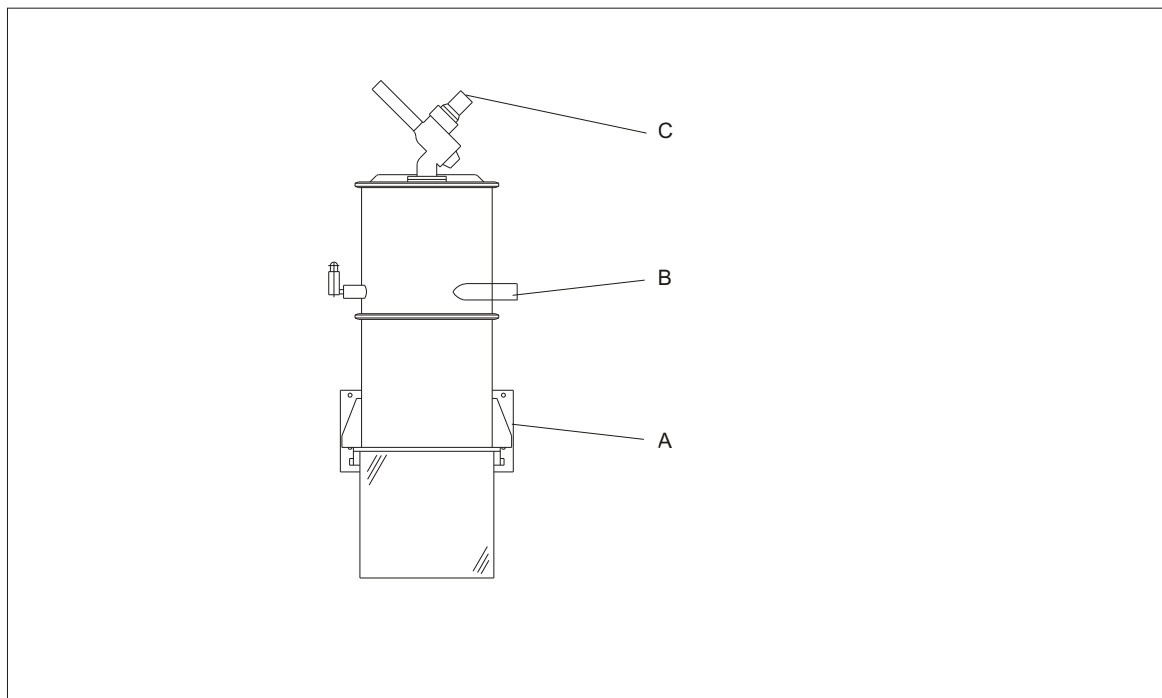

SFC-A

2.3. Compressed air supply

For operation of the valve, a compressed-air supply (1/4 ") is needed.

Check compressed air piping for correct installation and assembly.

Check fittings, length and quality of the hose connections for agreement with requirements.

The operating pressure is 5-6 bar (72-87 PSI) (system overpressure).

Check the compressed air supplied by the plant's supply network.

Adjust compressed air pressure to 5-6 bar (72-87 PSI) (system overpressure).

Compressed air must be dewatered and oiled.

Install a maintenance unit (pressure reducer with water separator and oiler) if required.

Connect the unit to the plant's supply network by means of a hose.



Depressurize compressed air supply lines which must be opened.



Compressed air must be dewatered and oiled.

Adjust pressure to a max. value of 6 bar (87 PSI) (system overpressure).

2.4. Electrical connection



The electrical connection may only be carried out by trained personnel.

The regulations of the local Electricity Board must be observed.

All work must be carried out with the unit disconnected from voltage and pressure supply.

It is not permitted for other persons to undertake the electrical connection.



Observe the electrical manual of the conveying system.

Put the plug into the socket of the safety filter and secure it with the holding clamp.

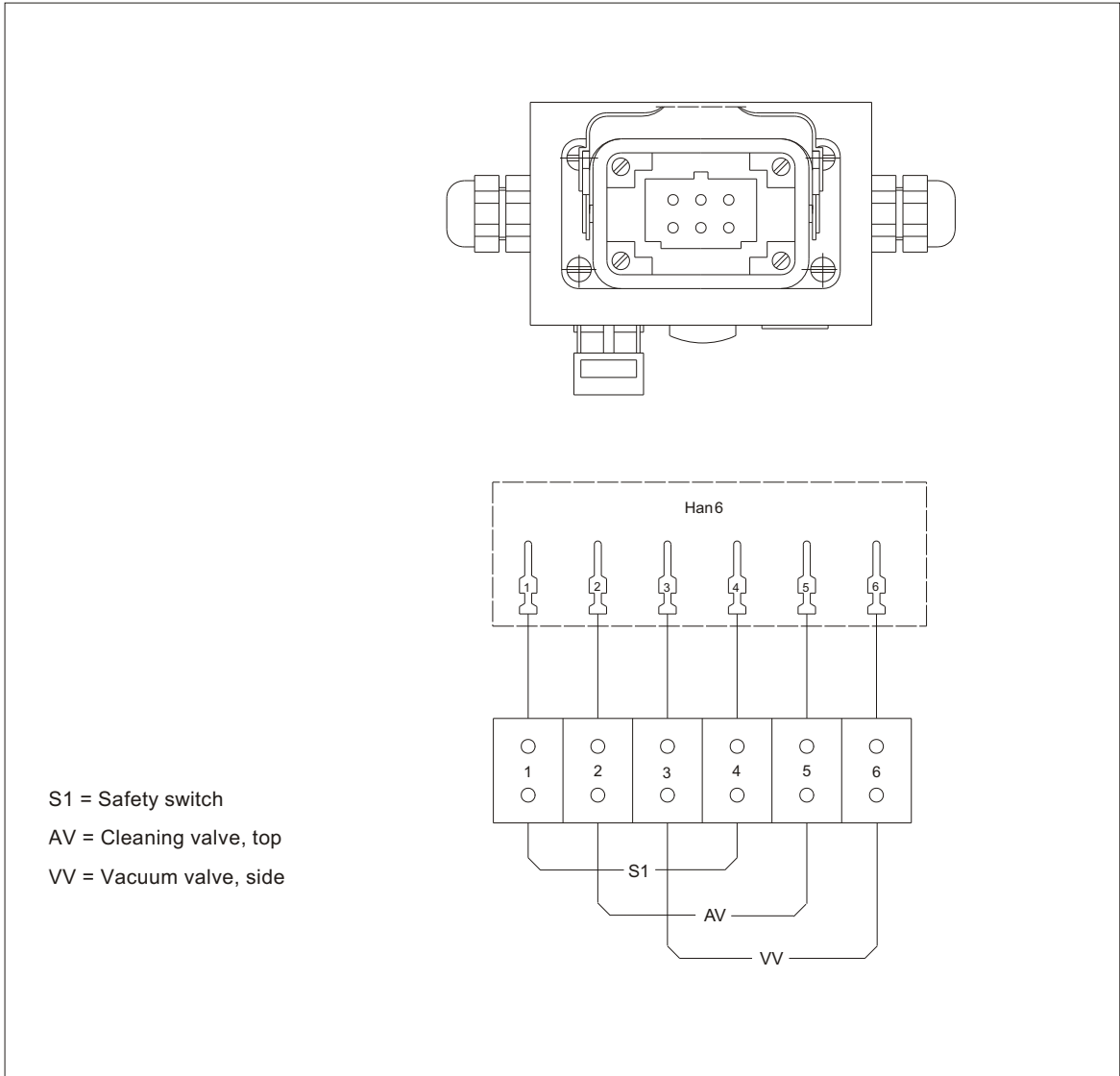

Connection housing

3. Functioning description



This functioning description is intended for all operating personnel of the equipment.

Prerequisite for this functioning description is general knowledge of conveying systems.

Ensure in each case that the operating personnel are sufficiently informed.



The safety filter may only be used together with a conveying system.

3.1. General

The safety filter is used to clean the vacuum air of the entire system and must be installed in every multi-location suction conveyor system .

A filter cartridge inside the safety filter separates the vacuum air from the dust particles flowing along with it. Vacuum pressure is built up in the safety filter following a filter monitoring period. Surrounding air is conducted into the safety filter by means of a valve. The direction of flow is opposite to the normal direction of flow. The dust is blown through the filter cartridge and collected in a receptacle.

No materials are conveyed during the cleaning procedure. The cycle, during which the filter cartridge is cleaned, is adjustable. Observe the operating instructions of the conveyor system.



The filter cleaning procedure is carried out while the vacuum generator is running.

The collecting container can be opened by hand for cleaning. The correct seating of the collecting container is monitored by a safety switch.

The number and way of the setting depends on the connected conveying control.



The filter cannot be cleaned unless the collecting container is correctly inserted.

4. Putting into operation



This chapter is intended for operating personnel.

Prerequisite for this chapter is general knowledge of the operation of conveying systems.

Also prerequisite for this chapter is that the functioning description has been read and understood.

Ensure in each case that the operating personnel are sufficiently informed.



Check the compressed-air supply (max. 5-6 bar (72-87 PSI) system overpressure).

Check the connections of the lines (conveying lines and vacuum lines).

Check to make sure the collecting container is correctly inserted.

Check the electrical connection.



The safety filter can only be used together with a conveying system.

4.1. Checking the settings of the conveying control

The number and way of the setting depends on the connected conveying control. This is a description of two possibilities.

Surveillance time

This is safety filter monitoring time between two cleanings. Has this time passed, the safety filter ist cleaned automatically.

Cleaning cycles

Number of cleaning pulses during a cleaning process.

4.2. Checking the line system

Remove the flexible line from the connected material receptacle.

Start a conveying procedure.

Use your hand to cover the open end of the line.

As the vacuum generator runs up, you must feel the suction with your hand within a few seconds.

If no vacuum pressure is felt, the system of lines is leaking.

Check the system of lines and seal off the leak.

Start the conveying procedure.

Connect the conveyor line again.

5. Maintenance



This chapter is intended for persons with skills in electrical and mechanical areas due to their training, experience and received instructions.

Personnel using the instructions in this chapter must be instructed of the regulations for the prevention of accidents, the operating conditions and safety regulations and their implementation.

Ensure in each case that the personnel are informed accordingly.

For maintenance work taking place at heights of over approx. 6 feet, use only ladders or similar equipment and working platforms intended for this purpose. At greater heights, the proper equipment for protection against falling must be worn.

Use only suitable lifting gear which is in proper working order and load suspension devices with sufficient carrying capacity. Do not stand or work under suspended loads!

Ensure that the electric motors/switch cabinets are sufficiently protected against moisture.

Use only suitable workshop equipment.

Before starting maintenance work, appoint a supervisor.

Inform the responsible personnel before maintenance work on the system is started.

Never operate the equipment when partially dismantled.

All maintenance and repair work not described in this chapter may only be carried out by Sterling service personnel or authorized personnel (appointed by Sterling).



Disconnect the equipment from mains supply before starting maintenance procedures to ensure that it cannot be switched on unintentionally.

Depressurize all compressed air piping of the equipment before starting maintenance work.



Please observe the maintenance intervals.

Before starting maintenance work, clean the equipment of oil, fuel or lubricants.

Ensure that materials and incidentals required for operation as well as spare parts are disposed of properly and in an environmentally sound manner.

Use only original Sterling spare parts.

Keep record of all maintenance and repair procedures.

5.1. Maintenance intervals

Daily:	<p>Check warning signs on equipment for good legibility and completeness.</p> <p>Check the oil level in the oiler.</p> <p>Empty the water separator.</p> <p>Check operating pressure of the plant's supply network (5-6 bar (72-87 PSI) system overpressure).</p> <p>Check waste level in the collecting container.</p>
Weekly/monthly:	<p>Clean filter cartridge in the safety filter (depending on accumulation of dust earlier!).</p>
Every six months:	<p>Check all electrical and mechanical connections for secure fit.</p> <p>Replace the filter cartridge (depending on accumulation of dust earlier!).</p> <p>Check the sealing rings of the nonreturn valve and the outlet flap.</p>



This maintenance schedule is calculated for 3-shift operation.



Only the Sterling service should put the one-way restrictor into action.

The given maintenance intervals are average values.

Check whether in your individual case the maintenance intervals must be shortened.

5.2. Clean collecting container



For cleaning of the collecting container, the plant should be switched off.

Open the toggle-type fasteners (C) on the support (B). The collecting container (A) turns down together with the holding clamp.

Pull the collecting container (A) out of the holder.

Clean the collecting container (A).

Reinstall the collecting container (A) in the holder.

Close the holder (B) and close the toggle-type fasteners (C).

Check the collecting container for tightness.

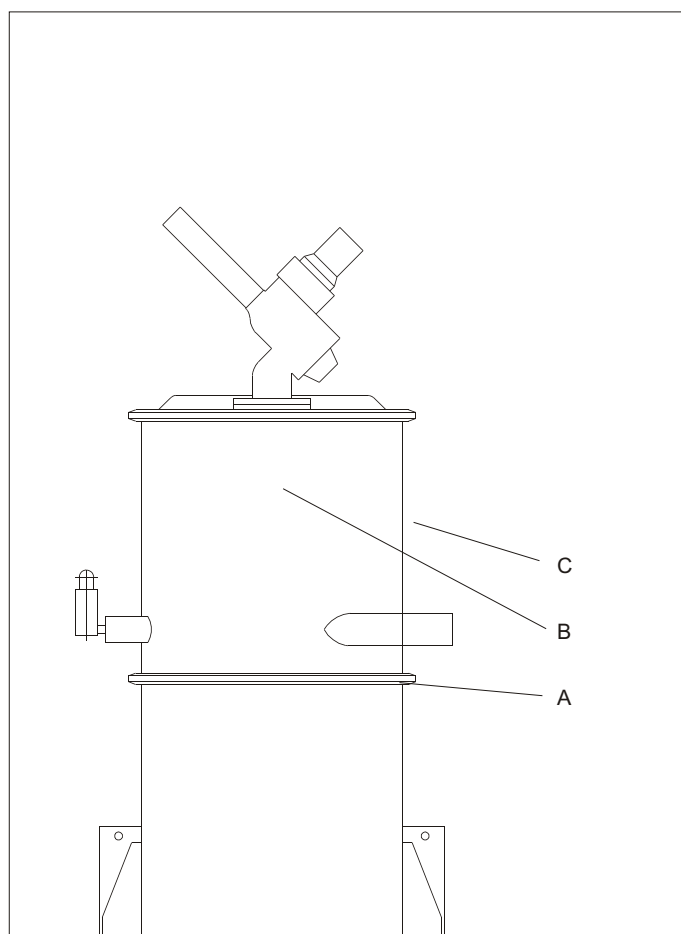

SFC-A

5.3. Clean/replace filter cartridge



Stop the conveying procedure.

Switch off the conveying system at the main switch.

Interrupt the mains supply.

Set all compressed-air lines at zero pressure.



Clogged filter cartridges reduce conveyor performance.

Loosen the tightening strap (B) between the separator lid (A) and separator container (C).

Remove the separator lid (A) from the separator container (C).

Pull the filter cartridge out of the separator container (C).

Use compressed air to blow through the filter cartridge from the inside to the outside **or** replace the filter cartridge.

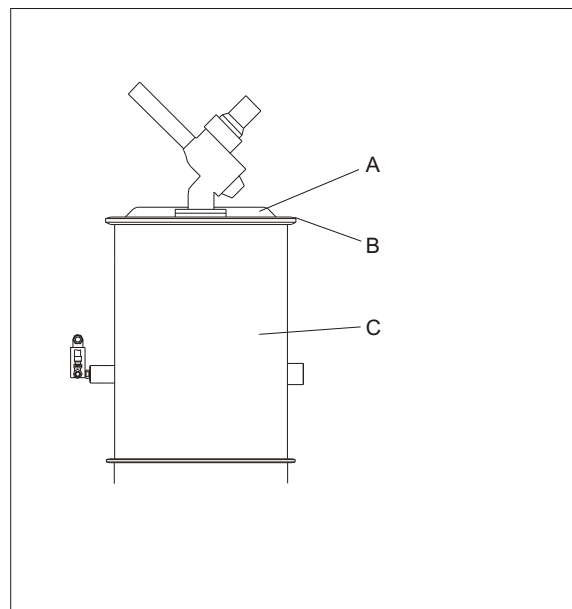

SFC-A

Install the filter cartridge in the separator container (C).

Install the separator lid (A) on the separator container (C).

Mount the tightening strap (B) between the separator lid (A) and the separator container (C).



Order number

filter cartridge: ID 86348

6. Technical data

Versions: SFC-A 40/50
..... SFC-A 65
Height: 1500 mm (56") max.
Diameter separator container: 400 mm (15.75")
Weight: approx. 53 kg (123.5 lbs.)
Filter cartridge: paper fleece
Filter surface: 1.6 m (63")
Compressed air supply: 4-6 bar (72-87 PSI) system overpressure

6.1. Data sheet

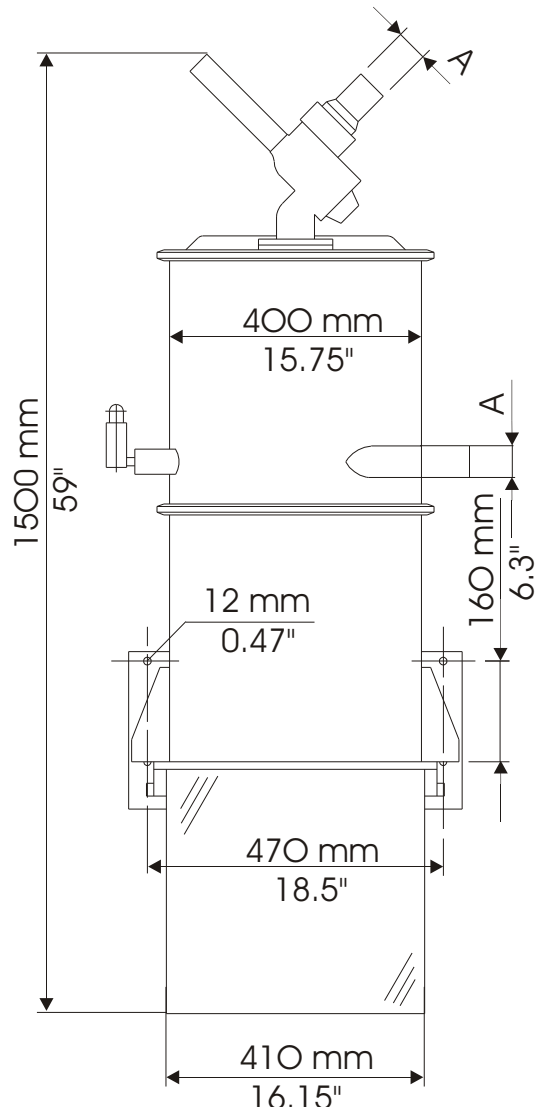
**A**

SFC-A 40: 40 mm; 1,6"

SFC-A 50: 50 mm; 2,0"

SFC-A 65: 65 mm; 2,5 "

Dimensions in mm. Specifications may be subject to alterations.

7. Appendix

7.1. Spare parts list



This spare parts list is intended to be used only by trained personnel.

Other persons are not permitted to modify or repair the equipment.

SFC-A 40/50/65

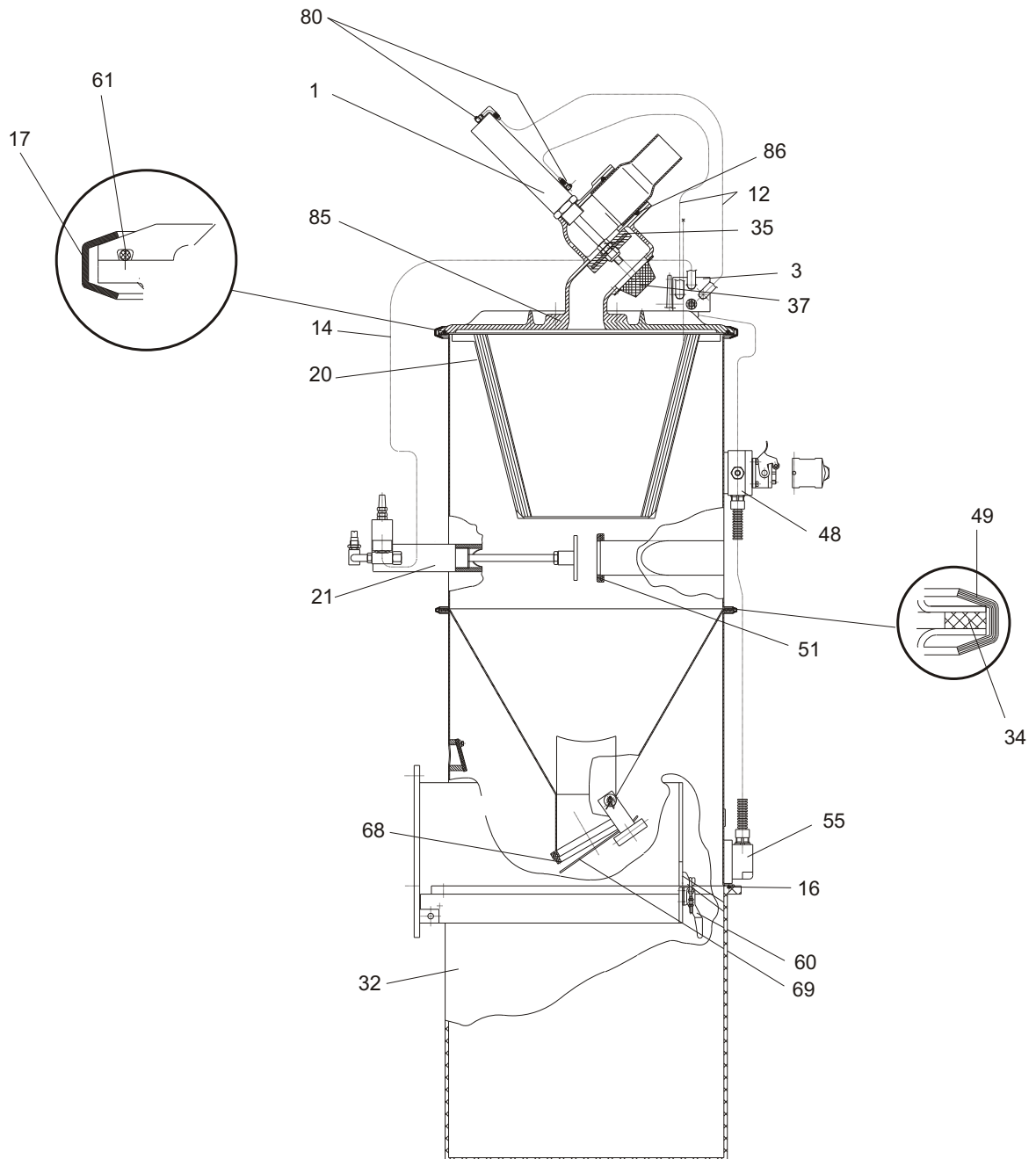

Pos.	Orderno.	Name
01	93551	Compressed-air cylinder
03	96372	Solenoid valve
12	98177	PVC fabric hose (0.7 m)(27.6")
14	98706	PVC fabric hose (1.0 m)(39.4")
16	95417	Sealing (1.35 m)(53.15")
17	93569	Profile tension ring
20	86348	Filter cartridge, conical 1.6 m(63")
21	27086	Compressed-air cylinder
32	09042	Container
34	99839	Sealing (1.4 m)(55.1")
35	15110	Sealing
37	09046	Filter
48	17011	Connection housing
49	99876	Profile tension ring
51	85610 17989	Sealing SFC-A 40/65 Sealing SFC-A 65
55	93570	Safety switch
60	96480	Toggle-type fastener
61	95881	Sealing (1.35 m)(53.15")
68	99880	Sealing (0.6 m)(23.6")
69	00159	Outlet flap
80	86640	Valve
85	13020	Sealing
86	88141	Valve

Free Manuals Download Website

<http://myh66.com>

<http://usermanuals.us>

<http://www.somanuals.com>

<http://www.4manuals.cc>

<http://www.manual-lib.com>

<http://www.404manual.com>

<http://www.luxmanual.com>

<http://aubethermostatmanual.com>

Golf course search by state

<http://golfingnear.com>

Email search by domain

<http://emailbydomain.com>

Auto manuals search

<http://auto.somanuals.com>

TV manuals search

<http://tv.somanuals.com>