



SF Series Fiberglass Cooling Towers

Part Number: 882.00440.00
Bulletin Number: SC6-610.5
Effective: 6/15/07

Write Down Your Serial Numbers Here For Future Reference:

_____	_____
_____	_____
_____	_____

We are committed to a continuing program of product improvement. Specifications, appearance, and dimensions described in this manual are subject to change without notice.

DCN No. _____
© Copyright 2007
All rights reserved.

Shipping Information

Unpacking and Inspection

You should inspect your equipment for possible shipping damage. Thoroughly check the equipment for any damage that might have occurred in transit, such as broken or loose wiring and components, loose hardware and mounting screws, etc.

In the Event of Shipping Damage

According to the contract terms and conditions of the Carrier, the responsibility of the Shipper ends at the time and place of shipment.

Notify the transportation company's local agent if you discover damage

Hold the damaged goods and packing material for the examining agent's inspection. **Do not return any goods before the transportation company's inspection and authorization.**

File a claim with the transportation company. Substantiate the claim by referring to the agent's report. A certified copy of our invoice is available upon request. The original Bill of Lading is attached to our original invoice. If the shipment was prepaid, write us for a receipted transportation bill.

Advise customer service regarding your wish for assistance and to obtain an RMA (return material authorization) number.

If the Shipment is Not Complete

Check the packing list as back-ordered items are noted on the packing list. In addition to the equipment itself, you should have:

- Bill of lading
- Packing list
- Operating and Installation packet
- Electrical schematic and panel layout drawings
- Component instruction manuals (if applicable)

Re-inspect the container and packing material to see if you missed any smaller items during unpacking.

If the Shipment is Not Correct

If the shipment is not what you ordered, please **contact the parts and service department immediately** at (262) 641-8610. Have the order number and item number available.

Hold the items until you receive shipping instructions.

Returns

Do not return any damaged or incorrect items until you receive shipping instructions from the shipping department.

Table of Contents

CHAPTER 1: SAFETY	6
1-1 How to Use This Manual	6
<i>Safety Symbols Used in this Manual</i>	6
1-2 Warnings and Precautions	7
1-3 Responsibility	7
CHAPTER 2: FUNCTIONAL DESCRIPTION	8
2-1 Models Covered in This Manual.....	8
2-2 General Description	8
2-3 Standard Features	8
<i>Materials of Construction</i>	8
2-4 Optional Features.....	9
CHAPTER 3: INSTALLATION	10
3-1 Tower Installation Location.....	10
<i>Roof Installation</i>	10
<i>Ground Installation</i>	10
<i>Alternative Installations</i>	10
3-2 Assembling the Cooling Tower in the Field	12
3-3 Rigging.....	13
3-4 Installing the Fan Package.....	13
3-5 Installing Piping	13
3-6 Setting Up the Water Balancing Valve	16
3-7 Initial Start-up.....	16
CHAPTER 4: OPERATION	17
4-1 Bleed-Off and Evaporation Rates.....	17
4-2 Winter Operation Considerations	17
CHAPTER 5: MAINTENANCE	18
5-1 Preventative Maintenance.....	18
<i>Water Treatment</i>	18
<i>Routine Maintenance</i>	18
5-2 Corrective Maintenance	19
<i>Replacing Nozzles and Fill</i>	19
CHAPTER 6: APPENDIX	20
6-1 Technical Assistance	20
<i>Parts Department</i>	20
<i>Service Department</i>	20
<i>Sales Department</i>	20
<i>Contract Department</i>	20
6-2 Drawings and Specifications	21

6-3	Parts List	24
6-4	Electrical Schematics	25

List of Figures

Figure 1: Structural Steel Support Requirements	11
Figure 2: Rigging Arrangement	13
Figure 3: Cooling Tower with Tower Reservoir Piping Diagram	14
Figure 4: Cooling Tower with Basin as Reservoir Piping Diagram	14
Figure 5: Flexible PVC Outlet Coupler	15
Figure 6: Throttling Valve Pressures	16
Figure 7: Dimensions and Weights	21
Figure 8: Tower Performance①	22
Figure 9: Cooling Tower Nozzle Capacity	23
Figure 10: Supplied Parts for Field Assembly	24
Figure 11: Spare Parts List	24
Figure 12: Typical Wiring Diagram	25

Chapter 1: Safety

1-1 How to Use This Manual

Use this manual as a guide and reference for installing, operating, and maintaining your equipment. The purpose is to assist you in applying efficient, proven techniques that enhance equipment productivity.

This manual covers only light corrective maintenance. No other maintenance should be undertaken without first contacting a service engineer.

The Functional Description section outlines models covered, standard features, and optional features. Additional sections within the manual provide instructions for installation, pre-operational procedures, operation, preventive maintenance, and corrective maintenance.

The Installation chapter includes required data for receiving, unpacking, inspecting, and setup of the equipment. We can also provide the assistance of a factory-trained technician to help train your operator(s) for a nominal charge. This section includes instructions, checks, and adjustments that should be followed before commencing with operation of the equipment. These instructions are intended to supplement standard shop procedures performed at shift, daily, and weekly intervals.

The Operation chapter includes a description of electrical and mechanical controls, in addition to information for operating the equipment safely and efficiently.

The Maintenance chapter is intended to serve as a source of detailed assembly and disassembly instructions for those areas of the equipment requiring service. Preventive maintenance sections are included to ensure that your equipment provides excellent, long service.

The Troubleshooting chapter serves as a guide for identification of most common problems. Potential problems are listed, along with possible causes and related solutions.

The Appendix contains technical specifications, drawings, schematics, and parts lists. A spare parts list with part numbers specific to your machine is provided with your shipping paperwork package. Refer to this section for a listing of spare parts for purchase. Have your serial number and model number ready when ordering.

Safety Symbols Used in this Manual

The following safety alert symbols are used to alert you to potential personal injury hazards. Obey all safety messages that follow these symbols to avoid possible injury or death.

Danger! ***DANGER*** indicates an imminently hazardous situation which, if not avoided, will result in death or serious injury.

Warning! ***WARNING*** indicates a potentially hazardous situation or practice which, if not avoided, could result in death or serious injury.

Caution! ***CAUTION*** indicates a potentially hazardous situation or practice which, if not avoided, may result in minor or moderate injury or in property damage.

1-2 Warnings and Precautions

Our equipment is designed to provide safe and reliable operation when installed and operated within design specifications, following national and local safety codes.

To avoid possible personal injury or equipment damage when installing, operating, or maintaining this equipment, use good judgment and follow these safe practices:

- ☑ Follow all **SAFETY CODES**.
- ☑ Wear **SAFETY GLASSES** and **WORK GLOVES**.
- ☑ Disconnect and/or lock out power before servicing or maintaining the equipment.
- ☑ Use care when **LOADING, UNLOADING, RIGGING, or MOVING** this equipment.
- ☑ Operate this equipment within design specifications.
- ☑ **OPEN, TAG, and LOCK ALL DISCONNECTS** before working on equipment. You should remove the fuses and carry them with you.
- ☑ Make sure the equipment and components are properly **GROUND** before you switch on power.
- ☑ When welding or brazing in or around this equipment, make sure **VENTILATION** is **ADEQUATE. PROTECT** adjacent materials from flame or sparks by shielding with sheet metal. An approved **FIRE EXTINGUISHER** should be close at hand and ready for use if needed.
- ☑ Refrigeration systems can develop refrigerant pressures in excess of 500 psi (3,447.5 kPa/ 34.47 bars). **DO NOT CUT INTO THE REFRIGERATION SYSTEM. This must be performed by a qualified service technician only.**
- ☑ Do not restore power until you remove all tools, test equipment, etc., and the equipment and related components are fully reassembled.
- ☑ Only **PROPERLY TRAINED** personnel familiar with the information in this manual should work on this equipment.

We have long recognized the importance of safety and have designed and manufactured our equipment with operator safety as a prime consideration. We expect you, as a user, to abide by the foregoing recommendations in order to make operator safety a reality.

1-3 Responsibility

These machines are constructed for maximum operator safety when used under standard operating conditions and when recommended instructions are followed in the maintenance and operation of the machine.

All personnel engaged in the use of the machine should become familiar with its operation as described in this manual.

Proper operation of the machine promotes safety for the operator and all workers in its vicinity.

Each individual must take responsibility for observing the prescribed safety rules as outlined. All warning and danger signs must be observed and obeyed. All actual or potential danger areas must be reported to your immediate supervisor.

Chapter 2: Functional Description

2-1 Models Covered in This Manual

This manual covers fiberglass cooling tower models. Model numbers are listed on the serial tag. A model number followed by -Q is specially-constructed, and the information in this manual may not apply. Make sure you know the model and serial number of your equipment before contacting the manufacturer for parts or service.

2-2 General Description

The fiberglass cooling tower system is constructed of lightweight polyester-reinforced fiberglass for corrosion resistance and durability. PVC fill material resists decay, corrosion, and microorganisms, and handles temperatures up to 130°F (54°C). Access panels allow easy inspection of fill material. Fan blades are factory-tuned for optimum performance. ABS water distribution nozzles are pre-piped and feature a non-clogging design.

2-3 Standard Features

Materials of Construction

Component	Material
Shell	Fiberglass-reinforced polyester
Fan blade	Aluminum fabrication
Fan motor support	Galvanized, mild steel
Fill, eliminator	PVC Plastic
Louver pack	PVC Plastic
Nozzle	ABS plastic
Piping assembly	Schedule 80 PVC plastic
Fasteners	Stainless Steel
Support Feet	Fiberglass brackets standard
Bottom Outlet	Fiberglass
Water Balancing Valve	Aluminum

2-4 Optional Features

Side Outlet. The side outlet is used when the tower basin is used as a reservoir.

Starter Package. The starter package includes a starter, a remote On/Off switch, a thermostat, and a well.

Basin Reservoir. The basin reservoir includes an automatic float valve, overflow and drain connections, and an outlet basket strainer for towers with no inside reservoir.

Basin Heater. The basin heater includes a heater and a low water level heater shutoff. It is used on towers with basin reservoirs to guard against freeze-up when your tower system is shut down.

Structural Base. The structural base is a factory-provided structural steel mounting base. It speeds tower installation and gives your tower proper support.

Access Ladder. The access ladder meets OSHA specifications and allows for easier maintenance and inspection.

Chapter 3: Installation

3-1 Tower Installation Location

Roof Installation

Select a location over or nearest to the heaviest building structural members. These members should be outside load-bearing walls, building columns, or roof joists. You may need to spread the load over several structural members to provide support without over-stressing any one member. See Figure 1 on page 11 for structural steel support requirements. You are responsible for contacting a structural engineer to verify support requirements.

Choose a site with easy access to simplify routine maintenance. This consideration is especially important when a tower is located near a roof edge.

Avoid locations where wind currents can re-circulate tower discharge air.

Stay clear of roof discharge points. Avoid stacks, exhaust fans, dust collector discharges, or any process that can contaminate air circulating through the tower.

Caution! *Multiple tower installations require at least five feet (60"/ 152cm) clearance between towers to reduce freeze-ups. The manufacturer is not responsible for damages resulting from improper site selection.*

Ground Installation

Elevate the tower so that positive pressure is on pump suction and to allow maintenance access to the underside of the tower cell.

Alternative Installations

Outside Installation with the Pump Tank Reservoir Inside. Water exits the tower and drains to a pump tank reservoir inside the building below. The tower outlet must be at least three feet (approximately 1 meter) above the top of the pump tank. The outside tower basin must drain completely when shut down to avoid winter freeze up.

Outside Installation Using the Tower Basin as a Reservoir. Process pump suction piping is directly connected to the bottom outlet on the tower. Install the optional outlet basket filter and automatic float assembly. Contact the Sales department for this accessory kit.

Note: A dimension of 60" is required between the tower air inlet and the wall of a building. See above caution for required distance between towers.

Figure 1: Structural Steel Support Requirements

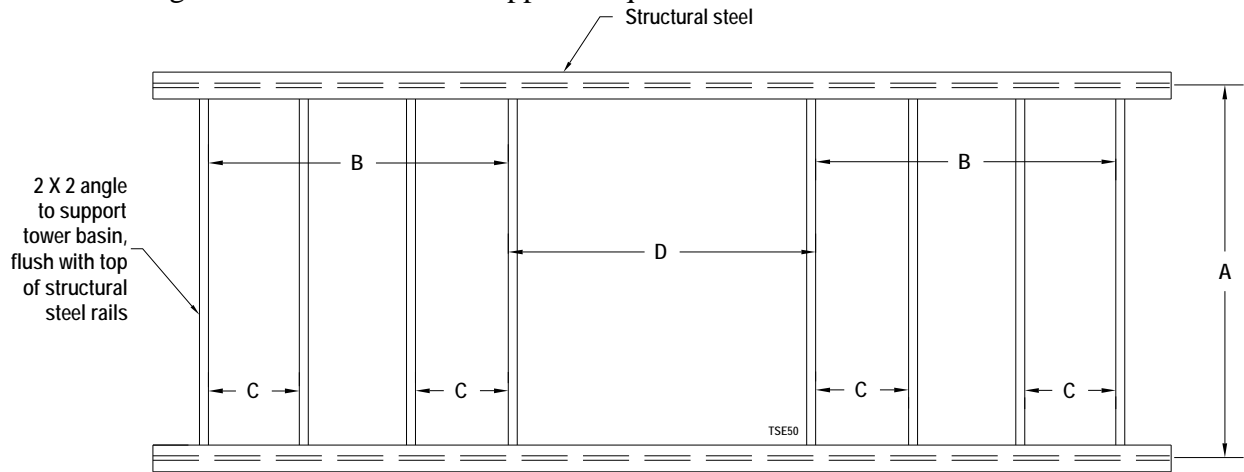

Model number	A		B		C		D	
	in.	cm	in.	cm	in.	cm	in.	cm
SF2003	52	132.1	50	127.0	16	40.6	78	175.3
SF2004	52	132.1	50	127.0	16	40.6	78	175.3
SF2005	68	172.7	67	170.2	22	55.9	78	175.3
SF2007	68	172.7	67	170.2	22	55.9	78	175.3
SF2009	87	221.0	85	215.9	28	71.1	78	175.3
SF2011	87	221.0	85	215.9	28	71.1	78	175.3
SF2015	87	221.0	85	215.9	28	71.1	78	175.3

Note: The illustration in Figure 1 shows structural steel with spacing for **two (2)** cooling towers. Your installation may vary.

Dimension A – Centerline for fiberglass mounting feet provided with cooling tower. This is so bolt holes can be made to secure the tower to the structural support.

Dimension B & C – Location of basin support steel.

Dimension D – Provides proper distance of 60” between cooling towers and distance between cooling tower and the wall of a building.

3-2 Assembling the Cooling Tower in the Field

Your cooling tower may have been shipped on two skids to reduce shipping charges.

One skid contains the lower section, identified by the black fill wrapped in plastic on the inside of the lower section. The second skid contains the top tower section bolted over the fan/motor assembly. Perform the following procedure to properly assemble the two sections if the sections shipped separately.

1. Remove the clear plastic protective wrapping from the fill.
2. Inspect both sections for any damage, and locate the red orientation mark on one of the vertical sides of each section.
3. The manufacturer supplies self-adhesive gasketing material to insure a water-tight seal between the top and bottom sections. Install this material on the top of the attachment flange on the lower section prior to mating the top and bottom sections. Make sure that the flange is clean, dry, and free of rough spots before applying the gasketing material.
4. Align the holes in the gasket with the bolt holes in the flange, then remove the paper on the back side. Cut the gasketing material to fit properly, and apply the gasket to the flange as you realign gasket holes with flange holes. Repeat on all four sides of the tower.
5. Apply silicone caulk in cut lines and voids to complete sealing between sections.
6. Unbolt the top section from the skid and make sure that the flange on the top section is clean, dry, and free of rough spots.
7. Place the upper section on the gasketed lower section, aligning the red orientation marks. Take care not to disturb the gasketing and silicone caulk while aligning bolt holes.
8. After aligning, bolt the two sections together with the fasteners provided. Use a flat washer under the bolt head on top and a flat washer, a lock washer, and nut on the bottom side of the flange.

3-3 Rigging

Handle the fiberglass cooling tower shell section very carefully. Until installed and properly supported, it is subject to handling damage. See Figure 2 for rigging information.

Caution! Use an appropriately rated hoist to support the equipment.

Figure 2: Rigging Arrangement

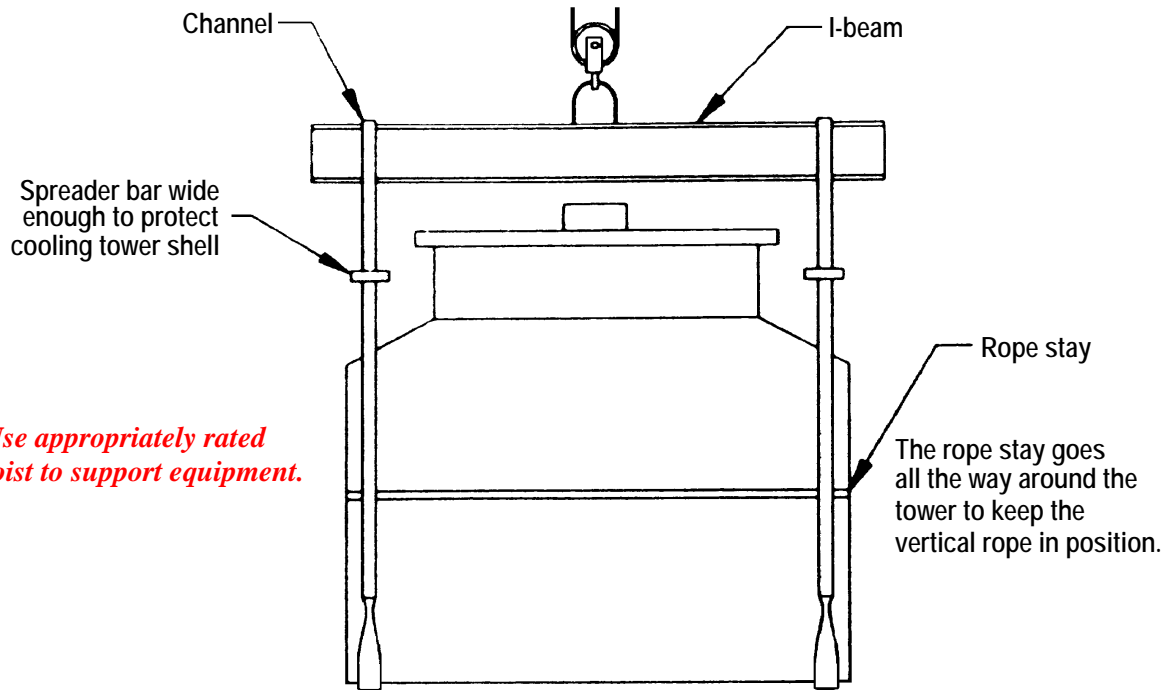

Caution! Use appropriately rated hoist to support equipment.

Do not let the rigging transfer any load to the cooling tower shell. Provide support to the bottom of the cooling tower when rigging. Do not rig from the corners of the optional base. Do not rig less than 8 inches from the corners.

3-4 Installing the Fan Package

Install the fan package after the tower is in position.

1. Remove the dunnage securing the fan package to the pallet.
2. Carefully rig the package using the lifting eyebolts provided.
3. Mounting holes have been pre-drilled at the factory; move the package into position and fasten it securely with the stainless steel hardware provided.

3-5 Installing Piping

Make sure that all piping attached to the cooling tower is externally supported. Do not support anything from the cooling tower shell.

The cooling tower and related fittings and connections are constructed of plastic materials and are not designed to bear external weight.

Do not apply high torque to the fittings that are made up into the tower fittings. Use a backup wrench when applying torque to the fittings.

Install the piping according to the piping diagrams in Figure 3 on page 14, Figure 4 on page 14, and Figure 5 on page 15.

Figure 3: Cooling Tower with Tower Reservoir Piping Diagram

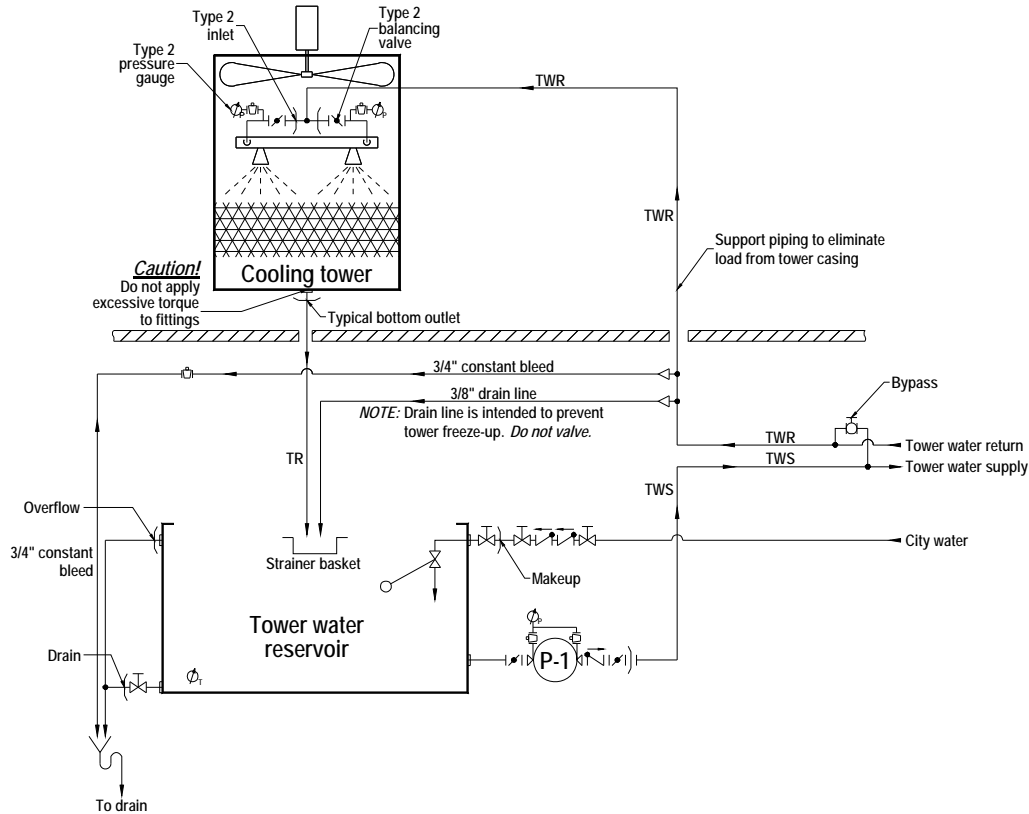

Figure 4: Cooling Tower with Basin as Reservoir Piping Diagram

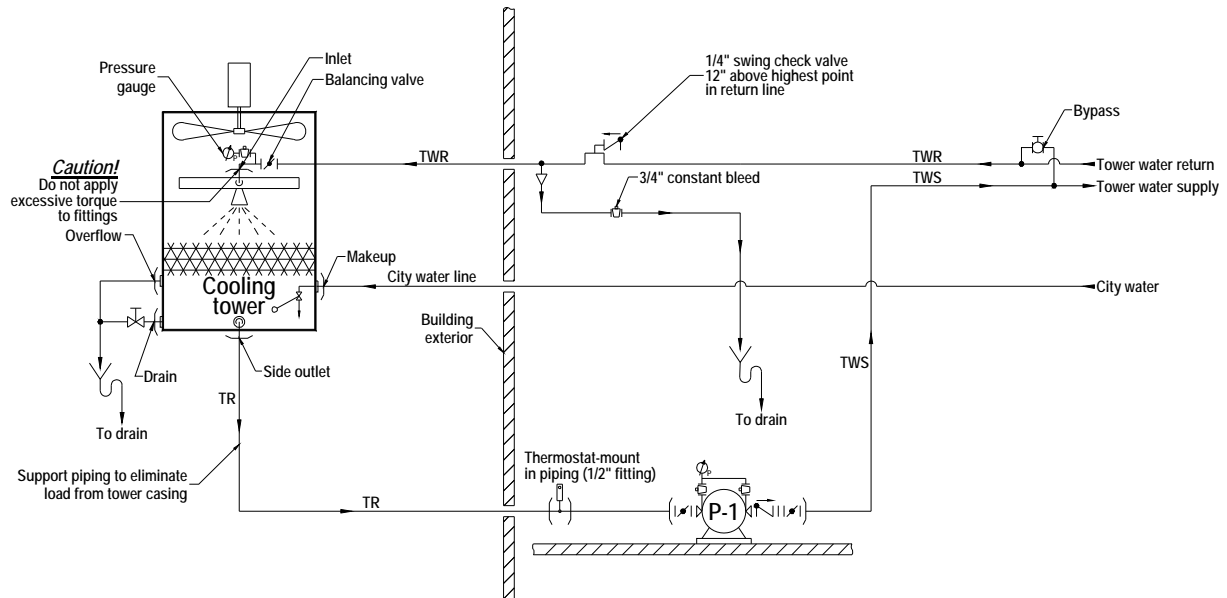
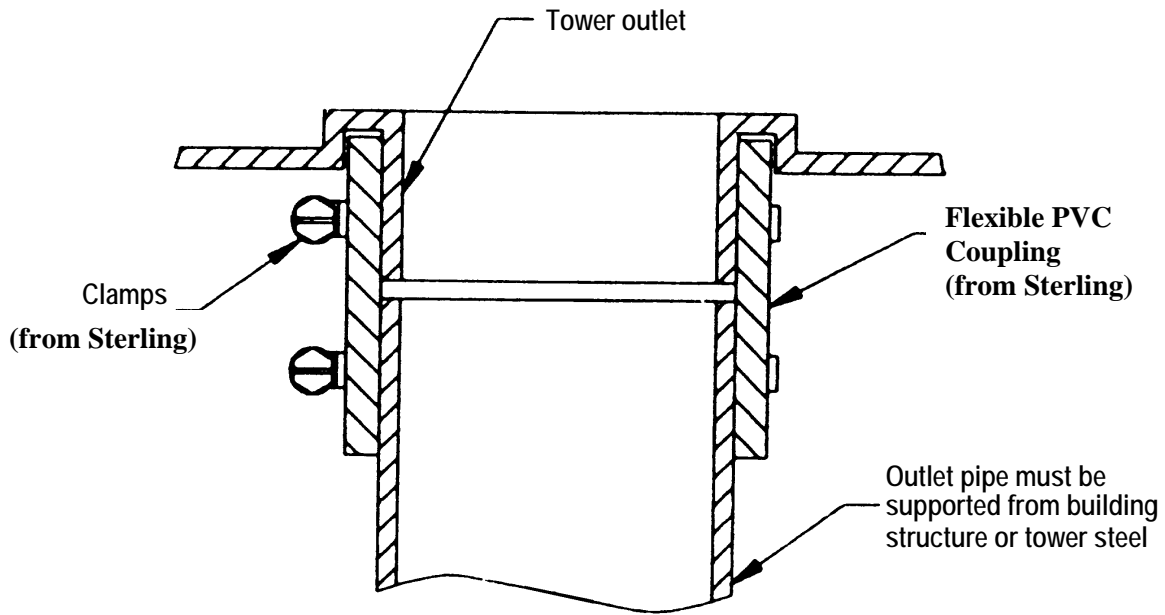

Figure 5: Flexible PVC Outlet Coupler



3-6 Setting Up the Water Balancing Valve

Install the plug provided in the unused water inlet on the side of the tower. Tighten and check for leaks.

To prevent damage to the tower fill material, use the water throttling valve and pressure gauge to regulate the water pressure to the tower spray nozzle(s). The recommended throttling valve is a butterfly-type valve that can be locked in the correct position with a locknut. See Figure 6 for recommended throttling valve pressures.

Figure 6: Throttling Valve Pressures

Model	Pressure	
	psig	KPa
SF2003	10 psig	68.95
SF2004	7 psig	48.26
Sf2005	3 psig	10.68
SF2007	5 psig	34.47
SF2009	6 psig	41.37
SF2011	8 psig	55.16
SF2015	10 psig	68.95

Warning! Exceeding these pressure limits will damage the tower fill and nozzle and void the tower warranty.

3-7 Initial Start-up

Check for proper rotation on all fan and pump motors. Refer to the arrows atop the tower and on pump housings.

Fill the system with water and adjust the float valve if you are using a float. Maintain a water level in the tower basin approximately one inch (25 mm) below the overflow opening.

The tower basin acts as a sump to maintain water level. Towers using inside tanks do not carry water in the basin.

Chapter 4: Operation

4-1 Bleed-Off and Evaporation Rates

A proper bleed-off rate is important to limit the concentration of minerals and foreign materials in re-circulated water. A bleed-off equal to the evaporation rate, normally about two gallons per hour per ton (7.57 liters per hour per 3,780 Kcal/hr), is sufficient for many makeup water conditions. Refer to the suggested bleed-off arrangements in Figure 3 and Figure 4 on pages 14 and 14 for more information. For automatic bleed rate control, a conductivity controller is available through the Sales department.

4-2 Winter Operation Considerations

All cooling towers are subject to ice formation in sub-freezing weather. Your cooling tower requires a certain amount of attention and maintenance to prevent damage during these operating conditions.

Follow these guidelines to reduce the chance of ice buildup:

- Maintain full design flow. Any reduction in water flow greatly increases the probability of ice forming on and around the air inlet louvers.
- Do not use free cooling applications during freezing weather. Reduced water temperatures or loading dramatically increases the chance of ice formation. Make sure that the leaving water temperature is set above 80°F (27°C) during sub-freezing weather so heat from the water warms the air inlet louvers and reduces ice formation when the fan is off. Using a thermostat to control fan cycling by leaving water temperature is mandatory.
- Do not run fans backward to thaw ice. Ice can form on the fan ring, fan guard, and support structures, and can severely damage fan blades. Reversed airflow can also blow water vapor out onto the roof and create ice fields around the cooling tower.
- Maintain a heat load of at least 60% of tower capacity at all times during operation in freezing weather. A lack of substantial load can create uneven temperatures in the tower and cause freezing.
- If you shut down your cooling tower during freezing weather, you must drain it completely. We recommend that you use an indoor reservoir tank to permit water to drain into the tank on system shutdown, whether for emergencies or actual planned shutdowns.
- An alternative is to use basin heaters if a tower basin is used as a sump. Basin heaters are available as an option. However, basin heaters can permit freeze-up during power failures if water remains in the sump. The customer is responsible for determining risk factors for each specific application.

Chapter 5: Maintenance

5-1 Preventative Maintenance

Water Treatment

Control of slime, algae, and bacteria growth is extremely important. Cooling towers and reservoir pump tanks are superb environments for microorganism growth. Warm water, organic debris, and air encourage bacterial growth. Treat your system with chemicals (microbiocides) to control microorganism growth.

Caution! *Uncontrolled microorganism growth causes system problems such as fouling and corrosion, and can spread bacterially-transmitted diseases.*

You must reduce slime growth and bacterial contamination to eliminate disease-causing bacteria.

Properly used, environmentally approved microbiocide controls system bacteria. Chemical treatments must be regularly monitored by qualified personnel.

The manufacturer strongly recommends use of EPA-registered microbiocides on a regular basis. We do NOT recommend use of chlorine or backyard swimming pool chemicals. Permitting the discharge of such chemicals into a city sewer may violate local, state, and/or federal laws.

We offer a full-service water treatment program including chemicals, dispensing equipment, automatic bleed-off, and monthly water analysis. Contact the Parts and Service department for more information.

Routine Maintenance

- The fan motor has double-sealed bearings and needs no lubrication
- Inspect basket strainers (where used) and clean as needed.
- Check constant bleed back to the tank for flow during operation.
- Check the bleed-off line to verify that water flows to the drain during operation.
- Inspect the tower basin for dirt and debris, and clean as needed.
- Check the tower nozzle(s) for proper operation at full water flow.
- Check the water treatment equipment for proper operation. Refer to the information supplied with these devices.
- Check the throttling valve pressure gauge. The pressure should be within the recommendations in section 3-6.

5-2 Corrective Maintenance

Replacing Nozzles and Fill

The PVC fill used in these cooling towers provides years of maintenance-free service under normal conditions. If you discover dirty water or defective nozzle(s) damage the fill, you can order a replacement kit from the parts department.

You can easily remove and replace the fill by removing the tower access door on the side of the tower. Open the door to gain access to the nozzle system.

Chapter 6: Appendix

6-1 Technical Assistance

Parts Department

Call Toll-Free 7am–6pm CST [800] 423-3183 or call [262] 641-8610

Our Parts Department is ready to provide the parts to keep your systems up and running. OEM replacement parts ensure operation at design specifications. Please have the model and serial number of your equipment when you call. Consult the Customer Parts List included in your information packet for replacement part numbers.

Service Department

Call toll-free 8am–5pm CST [800] 783-7835 or call [262] 641-8610. Emergency Service is available 24 hours a day. We have a qualified service department ready to help. Service contracts are available for most of our products. www.acscustomerservice.com

Sales Department

Call [262] 641-8610 Monday–Friday, 8am–5pm CST

Our products are sold by a world-wide network of independent sales representatives. Contact our Sales Department for the name of the sales representative nearest you.

Contract Department

Call [262] 641-8610 Monday–Friday, 8am–5pm CST

Let us install your system. The Contract Department offers any or all of these services: project planning; system packages including as-built drawings; equipment, labor, and construction materials; union or non-union installations; and field supervision.

6-2 Drawings and Specifications

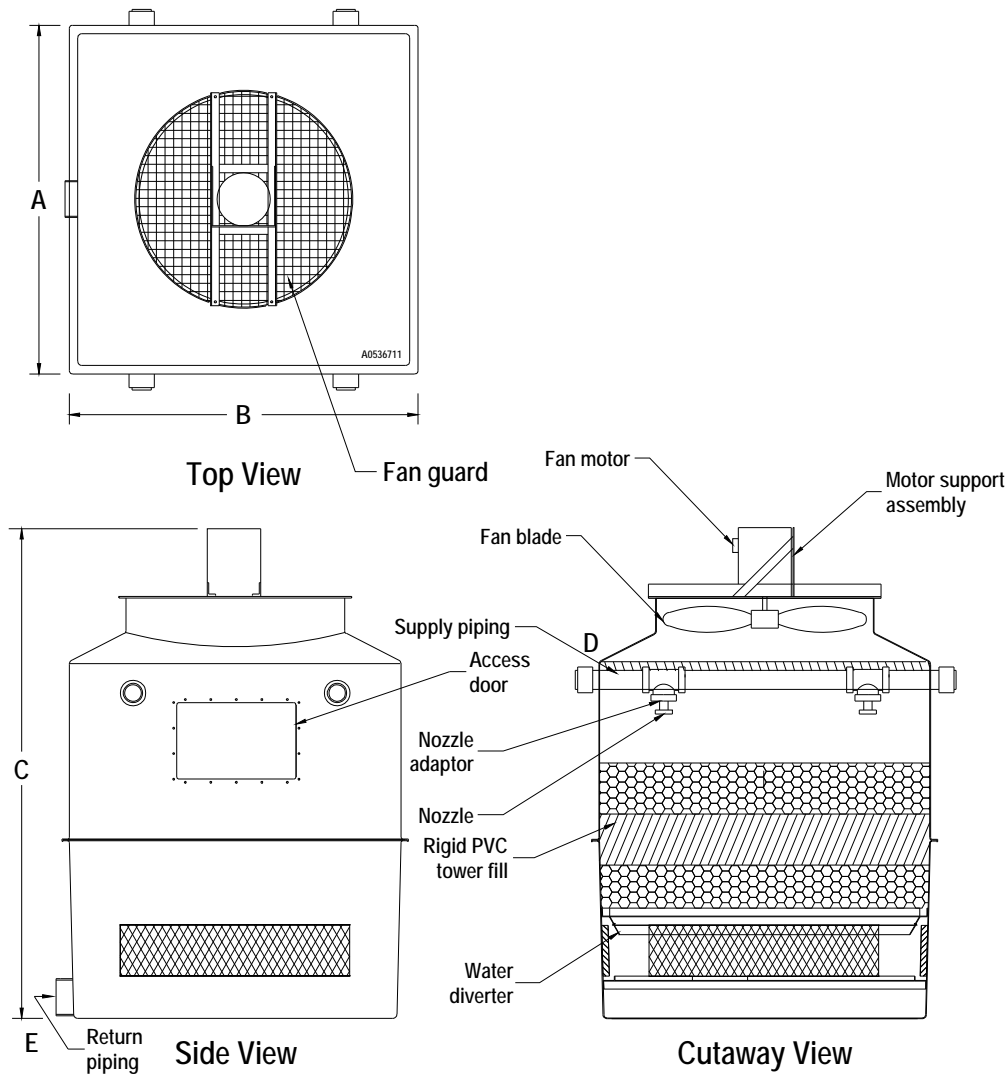

Figure 7: Dimensions and Weights

Model number	Dimensions										Weights			
	A		B		C		D (supply)		E (return)		Shipping		Operating	
	in.	cm	in.	cm	in.	cm	in.	mm ^⓪	in.	mm ^⓪	lbs.	kg	lbs.	kg
SF2003	64	163	64	163	104	264	3"	76.2 mm	4"	101.6 mm	600	273	1,300	591
SF2004	64	163	64	163	125	318	3"	76.2 mm	6"	152.4 mm	750	341	1,700	772
SF2005	82	208	82	208	121	307	4"	101.6 mm	8"	203.2 mm	1,400	636	2,900	1,317
SF2007	82	208	82	208	121	307	4"	101.6 mm	8"	203.2 mm	1,500	681	3,200	1,453
SF2009	100	254	100	254	123	313	4"	101.6 mm	8"	203.2 mm	1,950	886	3,800	1,726
SF2011	100	254	100	254	123	313	4"	101.6 mm	8"	203.2 mm	2,100	954	4,400	1,998
SF2015	100	254	100	254	124	315	4"	101.6 mm	8"	203.2 mm	2,600	1,181	5,200	2,361

① Millimeter measurement is approximate. Customer is responsible for converting to metric piping sizes.

Figure 8: Tower Performance^①

Model number	Cooling capacity		Nozzles no.	Fan motor			NEC amp draw 460/3/60	Nominal air flow	
	tons	Kcal/hr		hp	kW	rpm		cfm	cmh
SF2003	50	151,200	1	2	1.5	1,200	3.4	12,000	20,388
SF2004	75	226,800	4	5	3.7	1,200	7.6	18,000	30,582
SF2005	100	302,400	4	5	3.7	900	7.6	23,500	39,926
SF2007	125	378,000	4	5	3.7	900	7.6	26,000	44,174
SF2009	150	453,600	4	10	7.5	900	14.0	30,000	50,970
SF2011	175	529,200	4	10	7.5	900	14.0	33,000	56,067
SF2015	200	604,800	4	15	11.2	900	21.0	43,000	73,057

① Rating conditions are based on 78°F (26°C) wet bulb, 95°F (35°C) entering water temperature, and 85°F (29°C) leaving water temperature; flow capacity is based on 3 gpm/ton (2.563 lpm per 1,000 Kcal/hr).

Figure 9: Cooling Tower Nozzle Capacity

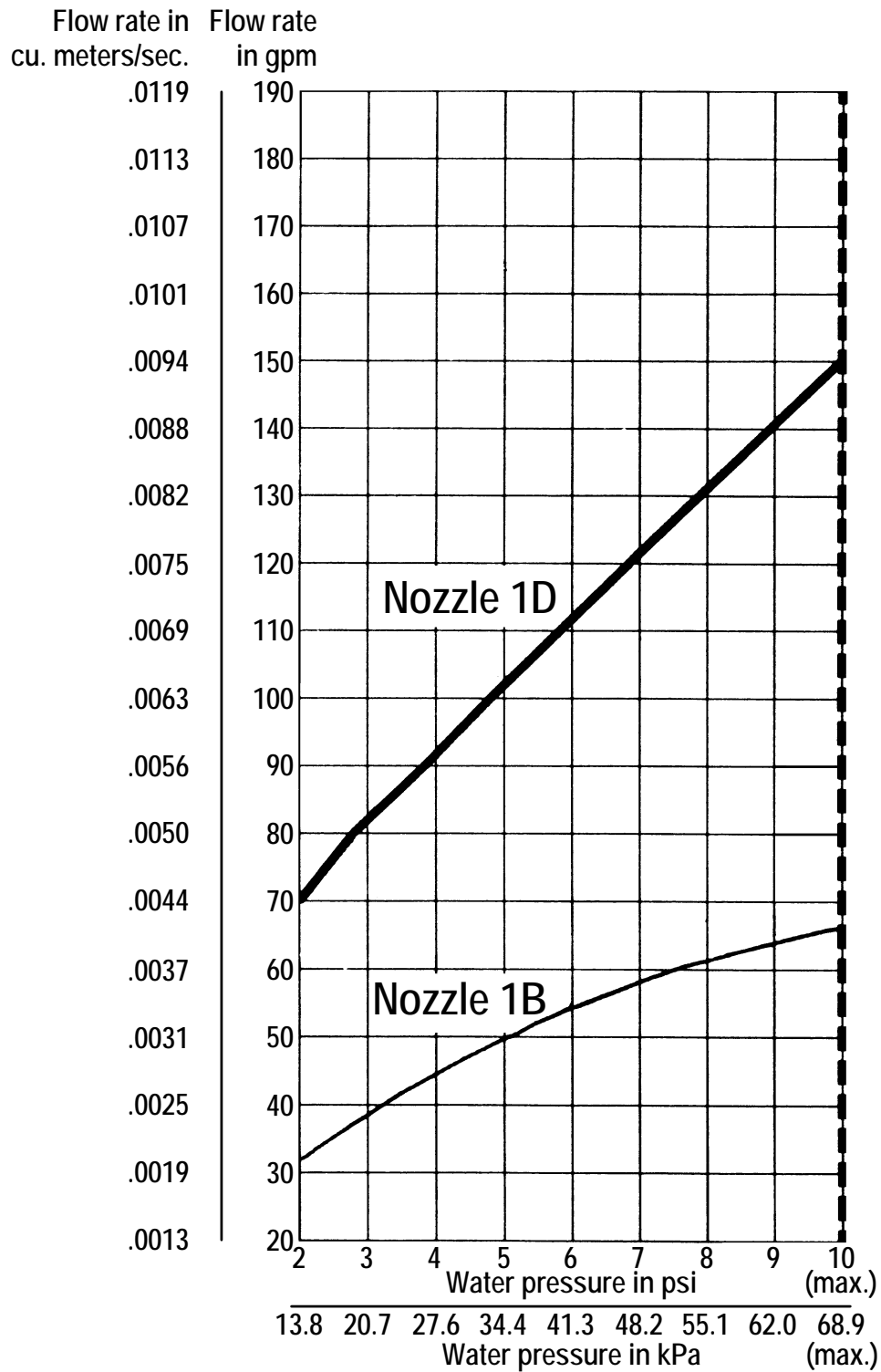

6-3 Parts List

Figure 10: Supplied Parts for Field Assembly

Part Number	Quantity	Description
A0101485	1	Silicone
A0533163	110	Stainless steel flat washers, 5/16"
A0539417	55	Stainless steel screws, 5/16"-18 x 1 3/4"
A0533167	55	Stainless steel hex nut, 5/16"-18
A0534122	55	Stainless steel split lock washers, 3/8"
A0539598	40 ft.	FG Tower gasketing

Figure 11: Spare Parts List

Part description	SF2003 ① ⑤		SF2004 ⑤		SF2005 ②		SF2007		SF2009		SF2011		SF2015	
	qty	Part no.	qty	Part no.	qty	Part no.	qty	Part no.	qty	Part no.	qty	Part no.	qty	Part no.
Shell, top section	1	A0533079	1	A0539552	1	A0536702	1	A0536702	1	A0535879	1	A0535879	1	A0539581
Shell, side outlet	1	A0533078	1	A0539550	1	A0536700	1	A0536700	1	A0535880	1	A0535880	1	A0539582
Shell, bottom outlet	1	A0536666	1	A0539551	1	A0536701	1	A0536701	1	A0536668	1	A0536668	1	A0539583
Tower access door	1	A0533082	1	A0533082	2	A0533082	2	A0533082	2	A0533082	2	A0533082	2	A0533082
Motor support assy.	1	A0533090	1	A0533090	1	A0536712	1	A0536712	1	A0539586	1	A0539586	1	A0539586
Fan Motor Spcr. Brkt.	1	A0539566	--	--	1	A0536717	--	--	--	--	--	--	--	--
Fan guard	1	A0533092	1	A0533092	1	A0536706	1	A0536706	1	A0535883	1	A0535883	1	A0535883
Fan motor ③	1	A0533094	1	A0539555	1	A0536709	1	A0536710	1	A0547120	1	A0547120	1	A0539577
Fan blade	1	A0533097	1	A0539556	1	A0547121	1	A0536708	1	A0541387	1	A0541387	1	A0539576
PVC fill ④	10	A0533101	15	A0539557	26	A0533099	39	A0533099	32	A0533099	48	A0533099	48	A0539578
Eliminator ③	5	A0533104	5	A0539558	13	A0533103	13	A0533103	16	A0533103	16	A0533103	16	A0539579
Louver	16	A0533106	16	A0539559	20	A0533106	20	A0533106	24	A0533106	24	A0533106	28	A0539580
Nozzle ③	1	A0064022	4	A0539572	4	A0064022	4	A0064022	4	A0064022	4	A0064022	4	A0064022
Nozzle adapter ③	1	A0101006	4	A0101006	4	A0101006	4	A0101006	4	A0101006	4	A0101006	4	A0101006
Nozzle ④	1	A0547133	4	A0547131	4	A0547131	4	A0547132	4	A0547132	4	A0547133	4	A0547133
Nozzle adapter ④	1	A0547130	4	A0547130	4	A0547130	4	A0547130	4	A0547130	4	A0547130	4	A0547130
PVC plug ⑥	1	A0500867	1	A0500867	2	A0500867	2	A0500867	2	A0500867	2	A0500867	2	A0500867
Flexible coupling	1	A0502553	1	A0502554	1	A0535957	1	A0535957	1	A0535957	1	A0535957	1	A0535957
Balancing valve ⑥	1	A0504422	2	A0504422	2	A0504422	2	A0504422	2	A0504422	2	A0504422	2	A0504422
Pressure gauge	1	A0102314	1	A0102314	2	A0102314	2	A0102314	2	A0102314	2	A0102314	2	A0102314
Strainer basket	1	A0500860	1	A0539574	1	A0535956	1	A0535956	1	A0535956	1	A0535956	1	A0535956
Float valve assy.	1	A0076209	1	A0076209	1	A0076209	1	A0538700	1	A0538700	1	A0538700	1	A0538700
Starter kit, 208 VAC	1	A0518023	1	A0518055	1	A0538701	1	A0538704	1	A0518030	1	A0518030	1	A0518059
Starter kit, 230 VAC	1	A0518024	4	A0518056	4	A0538702	4	A0538705	4	A0518031	4	A0518031	4	A0518060
Starter kit, 460 VAC	1	A0518025	4	A0518057	4	A0538703	4	A0538706	4	A0518032	4	A0518032	4	A0518061

- ① Fan motor spacer bracket part no. A0539566; available on FG2003 models only.
- ② Fan motor spacer bracket part no. A0536717; available on FG2005 models only.
- ③ Recommended spare parts prior to April 2002.
- ④ Recommended spare parts list after 2002.
- ⑤ Recommended spare parts prior to February 2005 (A0504421 and A0064023)
- ⑥ Recommended spare parts list after February 2005

6-4 Electrical Schematics

Figure 12: Typical Wiring Diagram

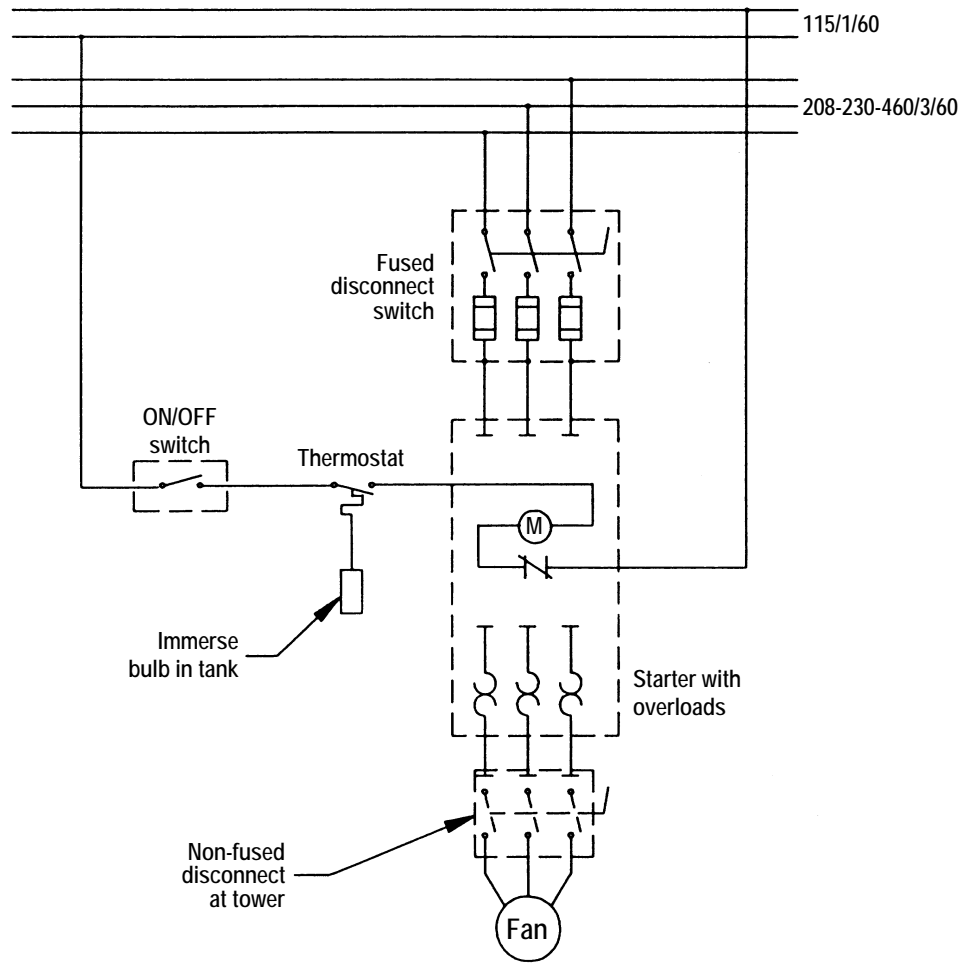

Free Manuals Download Website

<http://myh66.com>

<http://usermanuals.us>

<http://www.somanuals.com>

<http://www.4manuals.cc>

<http://www.manual-lib.com>

<http://www.404manual.com>

<http://www.luxmanual.com>

<http://aubethermostatmanual.com>

Golf course search by state

<http://golfingnear.com>

Email search by domain

<http://emailbydomain.com>

Auto manuals search

<http://auto.somanuals.com>

TV manuals search

<http://tv.somanuals.com>