



\$30.<sup>00</sup>

Operation and Installation Manual

# 6017 Series Large Hot Oil Temperature Control Units

*Important!* Read Carefully Before Attempting to Install or Operate Equipment



Part No. 682.91540.00

Revision 3

Bulletin No. SC1-655-3

Write down your unit serial number(s) \_\_\_\_\_  
here for future reference \_\_\_\_\_  
\_\_\_\_\_  
\_\_\_\_\_

Sterling/Sterlco is committed to a continuing program of product improvement.  
Specifications, appearance, and dimensions described in this manual  
are subject to change without notice.

|  |            |                        |
|--|------------|------------------------|
| © Copyright Sterling/Sterlco and Sterling, Inc. 2008 |            |                        |
| All rights reserved.                                 |            | Effective 4/29/2008    |
| Part No. 682.91540.00                                | Revision 3 | Bulletin No. SC1-655-3 |

# Safety Considerations

---

Sterling/Sterlco 6017 Series large hot oil temperature control units are designed to provide safe and reliable operation when installed and operated within design specifications, following national and local safety codes.

To avoid possible personnel injury or equipment damage when installing, operating, or maintaining this equipment, use good judgment and follow these safe practices:

- ☑ Follow all **SAFETY CODES**.
- ☑ Wear **SAFETY GLASSES** and **WORK GLOVES**.
- ☑ Disconnect and/or lock out power before servicing or maintaining the hot oil temperature control unit.
- ☑ Use care when **LOADING, UNLOADING, RIGGING, or MOVING** this equipment.
- ☑ Operate this equipment within design specifications.
- ☑ **OPEN, TAG, and LOCK ALL DISCONNECTS** before working on equipment. You should remove the fuses and carry them with you.
- ☑ Make sure the hot oil temperature control unit and components are properly **GROUND**ED before you switch on power.
- ☑ Do not jump or bypass any electrical safety control.
- ☑ Do not restore power until you remove all tools, test equipment, etc., and the hot oil temperature control unit and related equipment are fully reassembled.
- ☑ Only **PROPERLY TRAINED** personnel familiar with the information in this manual should work on this equipment.

# Table of Contents

---

|          |                                       |           |
|----------|---------------------------------------|-----------|
| <b>1</b> | <b>General Information .....</b>      | <b>7</b>  |
| 1-1      | Introduction .....                    | 7         |
| 1-2      | Necessary Documents .....             | 7         |
| 1-3      | Models Covered .....                  | 8         |
| 1-4      | Standard Features .....               | 8         |
| 1-5      | Available Options .....               | 9         |
| 1-6      | Feature Descriptions .....            | 9         |
| <b>2</b> | <b>Shipping Information.....</b>      | <b>17</b> |
| 2-1      | Unpacking and Inspection .....        | 17        |
| 2-2      | In the Event of Shipping Damages..... | 17        |
| 2-3      | If the Shipment is Not Complete.....  | 18        |
| 2-4      | If the Shipment is Not Correct .....  | 18        |
| 2-5      | Returns .....                         | 18        |
| <b>3</b> | <b>Installation.....</b>              | <b>19</b> |
| 3-1      | Work Rules .....                      | 19        |
| 3-2      | Installation Requirements.....        | 19        |
| 3-3      | Connecting Piping .....               | 20        |
| 3-4      | Making Electrical Connections .....   | 26        |

# Table of Contents

---

|          |  |              |
|----------|--|--------------|
| <b>4</b> | <b>Startup Preparations .....</b>                | <b>29</b>    |
| 4-1      | Starting the Unit .....                          | 29           |
| 4-2      | Shutting Down the Unit .....                     | 32           |
| 4-3      | Returning Fluid to the Tank.....                 | 32           |
| <b>5</b> | <b>Using Controls and Indicators .....</b>       | <b>34</b>    |
| 5-1      | The Microprocessor Controller.....               | 34           |
| 5-2      | Identifying M2B Controller Panel Components..... | 35           |
| 5-3      | Using M2B Controller Keys .....                  | 37           |
| 5-4      | Identifying Control Panel Switches.....          | 39           |
| 5-5      | Identifying System Status Board Indicators.....  | 41           |
| <b>6</b> | <b>Preventive Maintenance.....</b>               | <b>46</b>    |
| 6-1      | Periodic Checks .....                            | 46           |
| 6-2      | Routine Servicing .....                          | 47           |
| 6-3      | Draining the Unit for Storage.....               | 50           |
| 6-4      | Corrective Maintenance .....                     | 50           |
| 6-5      | Maintaining the Pump .....                       | See Addendum |
| <b>7</b> | <b>Troubleshooting .....</b>                     | <b>52</b>    |

# Charts and Figures

---

|          |  |           |
|----------|--|-----------|
| <b>1</b> | <b>6017 Series Hot Oil Large Temperature Control Unit and Specifications</b> | <b>16</b> |
| <b>2</b> | <b>6017 Unit Piping Setup</b>  | <b>16</b> |
| <b>3</b> | <b>Typical Flow Schematic</b>  | <b>24</b> |
| <b>4</b> | <b>Typical M2B Graphic and Button Control Panel</b>                          | <b>34</b> |
| <b>5</b> | <b>Control Panel Switches</b>  | <b>39</b> |
| <b>6</b> | <b>System Status Board Indicators</b>  | <b>41</b> |

## 1-1 Introduction

Your Sterling/Sterlco 6017 Series hot oil temperature control unit circulates thermal transfer-type oil through your process and to precisely, automatically, and reliably maintain it at a temperature you can select. The operating range of your temperature control unit is from 100°F to 550°F (38°C to 288°C). The unit is best suited for use with SterlTherm™ Heat Transfer Fluid. A recommended list of commercially available heat transfer fluids can be obtained through Sterling Customer Service.

Rapid recirculation of the fluid provides a close and uniform temperature relationship between the **TO PROCESS** and **FROM PROCESS** lines. This does, of course, depend on the configuration of your process, and any restrictions within the mold.

This recirculation, combined with the immersion heater and optional cooling capability, gives fast and accurate response to bring the fluid up to temperature, or to changes in the settings when needed.

Performance is assured through matching the unique Sterlco controllers to the Sterlco high temperature system. The two systems are fully integrated to achieve accurate control.

## 1-2 Necessary Documents

The following documents are necessary for the safe installation, operation, and maintenance of your Sterling/Sterlco 6017 Series hot oil large temperature control unit. You can obtain additional copies from Sterling, Inc. Make sure that appropriate personnel are familiar with these documents:

- This manual.
- The electrical schematic and connection diagram in the control enclosure.
- The manuals for accessories and options you've selected.
- The customer parts list in the control enclosure.

## 1-3 Models Covered

This manual lists installation, operation, and maintenance instructions for the 6017 Series hot oil large temperature control unit.

Model numbers are listed on the serial tag. A model number followed by **-Q** indicates a specially constructed unit, and not all information in this manual may apply. Make sure that you know the model number, serial number, and operating voltage of your unit if you contact Sterling, Inc.

## 1-4 Standard Features

- M2B microprocessor controller with fuzzy logic; includes diagnostic features with indicator and warning status lights
- Non-fused lockable rotary disconnect
- Dual stage immersion heater with IEC contactors
- 550°F (288°C) maximum operating temperature
- Branch fusing
- System status graphic display
- Pressure switch for low pump pressure shut-down
- NEMA 12 electrical enclosure
- UL listed subpanel
- To Process pressure gauge
- Independent safety thermostat
- Y strainer on From Process line
- A packed positive displacement pumps capable of reversing to evacuate the process
- Easily removable panels for quick access to internal components
- Audible alarm



## 1-5 Available Options

- Drain valve
- Manual bypass
- Hour meter; measures total pump run time hours
- General fault visual alarm
- Automatic venting sequence
- Low level alarm for reservoir
- M2B microprocessor controller options include:
  - 4-20 mA remote set point and retransmission
  - SPI protocol, RS-485
  - General protocols, types RS-232, -485
  - Remote sensor
- Heat exchanger options of
  - 3.9 sq. ft. (0.3627 sq. m)
  - 6.7 sq. ft. (0.6231 sq. m)
  - 13 sq. ft. (1.21 sq. m)
  - 21 sq. ft. (1.96 sq.m)
  - 27 sq. ft. (2.51 sq. m)
- Remote controller
- Lexan cover
- Mechanical Seal Pump
- Optional operating voltages of 208/3/60, 230/3/60, 575/3/60, 380/3/50, and 415/3/50
- Provisions for a Nitrogen Blanket on the Reservoir can drastically increase fluid life.

## 1-6 Feature Descriptions

### Immersion Heaters

The fluid is heated by the specially designed three-phase low watt density electrical immersion heater, and regulated by the controller. The standard heater has a steel sheath for low watt density and good heat transfer.

These models can be supplied with 50, 60, 75, 100, 120, 150, and 200 kW low watt density immersion heaters, depending upon the heating needs of the process. All models are built to provide full or partial heat as required by the process and determined by the controller, to provide more precise control.

## Heater Tank

The 6017 features a single pass heater tank. The tank is designed to maintain an optimum balance of fluid velocity versus watt density, and turbulence for excellent heat transfer, and minimal pressure drop. The high fluid velocity will greatly prolong the life of the heater and fluid.

## Pump

The pump is a packed, positive displacement pump. It features a nearly failure free design, and has proven itself after years of dependable service. It is well suited for use with a variety of commercially available heat transfer fluids. The pump has only two internal moving parts, and a specially designed seal to give years of trouble free service, even at high temperatures. The only routine maintenance required is weekly greasing and occasional packing and headspace adjustment; see Chapter 6 on Page 47 for more information.

The pump is capable of running in either direction. Thus, the pump reverse feature can be used to draw fluids back from the process. It is not necessary to install a service air line to purge the lines before changing molds. Since the pump is capable of achieving extremely high pressures, it is necessary to regulate the pressure through use of a regulating by-pass line (Fulflo valve). Because the pump is a positive displacement pump, it will supply the process with rated flow at or below the rated pressure.

The flow is constant until the pressure reaches the rated pressure. The pressure however is a function of frictional losses through the process that it is attached to. Systems with large process connections, ports, and piping will operate at low pressures. While systems with small process connections, ports, and piping will operate at higher pressures. Once the pressure requirements exceed the rated pressure, the fulflow valve will open and bypass the necessary fluid to prevent high pressures.

## Ful-Flo Valve

A regulating by-pass line featuring a Fulflo valve is standard in all units. This is a safety device to prevent excessive pressure in the event that the delivery line is obstructed. Each Fulflo is factory preset to limit system pressure as specified by the customer. It must not be tampered with in any way.

In the event of an obstruction in the line, the Fulflo will open and divert fluid from the delivery **TO PROCESS** line to the return **From Process** line. A constant flow of fluid is maintained through the heater tank to prevent damage to the heating elements and fluid.

## Cooling

### Optional

The Sterlco-designed shell and tube heat exchanger is provided as optional equipment in this unit. The design features U-tube construction and copper-nickel tubes for durability and optimal heat transfer.

The modular construction (unique to Sterlco units) allows the tube bundle to be easily removed for periodic cleaning. Additionally, check valves are installed on the water supply and drain lines to prevent water from back flowing into the heat exchanger from a closed drain or into the water supply piping.

The controller automatically regulates cooling by opening and closing the cooling solenoid. This allows the proper amount of oil to pass over the tubes of the heat exchanger. A water supply of 75 psi (517.1 kPa/5.2 bars) maximum is required for connection to the heat exchanger.

## Connection Lines

Connections for **TO PROCESS** and **FROM PROCESS** lines are:

- 2" NPT (50.8 mm) at 90 gpm (341 lpm)
- 2-1/2" NPT (63.5 mm) at 150 gpm (568 lpm)
- 3" NPT (76.2 mm) at 200 gpm (757 lpm)

Water connections for **COOLING WATER SUPPLY** and **COOLING WATER DRAIN** are:

- 3/4" NPT (19.1 mm) for 3.9 & 6.7 sq. ft. heat exchangers.
- 1" NPT (25.4 mm) for 13, 21, & 27 sq. ft. heat exchangers.

(See Chapter 3.) *The customer is responsible for conversions to metric standards.*

Sterling stocks many lengths of flexible metal hose; the part number is 572-16969. State the length of hose you want when ordering.

## **! WARNING**



**Component failure may result in high-temperature oil spray, causing serious injury or death.**

**Make sure hoses, valves, and other components installed in your process can withstand maximum temperature and pressure of the 6017 unit; check unit nameplate for specific capacities.**

**All components must be carefully inspected for condition before installing. Make sure you have factory components if you have any doubt.**

### **Electrical System Controls**

The electrical controls of your 6017 unit are specially engineered for reliability, safety and simplicity of operation. The switches are clearly labeled as to their function. Your 6017 unit has a system status board so you can evaluate the status and performance of the unit at a glance. Pilot lights are provided to indicate key unit functions.

An audible alarm is standard with your unit. The alarm will sound in the event of the following conditions:

- motor overload
- safety thermostat trip ( over temperature )
- low fluid pressure
- low fluid level (optional)
- high fluid level (optional)

Push the **ALARM SILENCE** button to silence the alarm. See Chapter 4 for more information on control functions.

## Electrical Panel and System Components

The pump motor and immersion heater operate on three-phase, 50/60 cycle, nominal voltage with the control circuit at 115 V single phase. The control circuit voltage is provided by a single phase machine tool transformer with primary fuse protection and a grounded secondary. A main power disconnect is included as for ease of service. The electrical panel is UL listed and complies with NEC provisions.

All components are IEC rated for long life and reduced maintenance. The heater elements are branch fused, and protected from contactor welding by a separate primary voltage contactor. The pump motor is controlled by a full voltage magnetic reversing starter, with fused branch circuit overcurrent and thermal overload protection. Many additional features are available as options.

A NEMA 12 enclosure is standard, with NEMA 4 available as an option.

## Air Purge

Upon initial start-up and mold/process change-out, you'll need to purge all air and water from the system. The 6017 unit has appropriate valving to ensure complete purging. Procedures are covered in Chapter 3.

### **! WARNING**



**Failure to purge the system of air before heating may result in serious injury or critical system and equipment damage.**

**Make sure you properly purge the system of air *before* starting the heater cycle.**

## Pressure Switch

A pressure switch is built into each unit to guard against heater damage. This feature prevents the heater elements from being energized unless the pump is running and fluid is in the system. After a preset time, the pump shuts down if the fluid pressure is not re-established. The pressure switch is preset at the factory; **do not tamper with it.**

## Safety Thermostat

The safety thermostat is mounted on the side of the heater tank. This is to guard against the unlikely event of “runaway” heating. If overheating does occur, the safety thermostat shuts down the heater outputs and sounds an audible alarm. A red pilot light on the status board also illuminates. The unit continues to pump fluid through the system to prevent heater damage. Auxiliary factory installed alarms such as beacons and klaxons are available as options.

The safety thermostat is a manual reset type. All controller functions are locked out until the red "STOP" button is pushed. It is imperative that a qualified maintenance technician determine and correct the cause of the fault **before** resuming operation.

## Reservoir Tank

A reservoir tank with sight gauge is standard; usable capacity is

- 40 gallons (151 liters) on 6017L & 6017M units
- 65 gallons (246 liters) on 6017P & 6017V units.

The tank permits thermal expansion of the heat transfer fluid, and provides make-up fluid.

# **! WARNING**



**The reservoir tank may cause serious injury if it ruptures from not being properly vented.**

**Make sure that the reservoir tank is always properly vented to prevent tank rupture.**

Figure 1  
 6017 Series Hot Oil Large Temperature Control Unit.  
 The unit shown below is a 6017P Model.

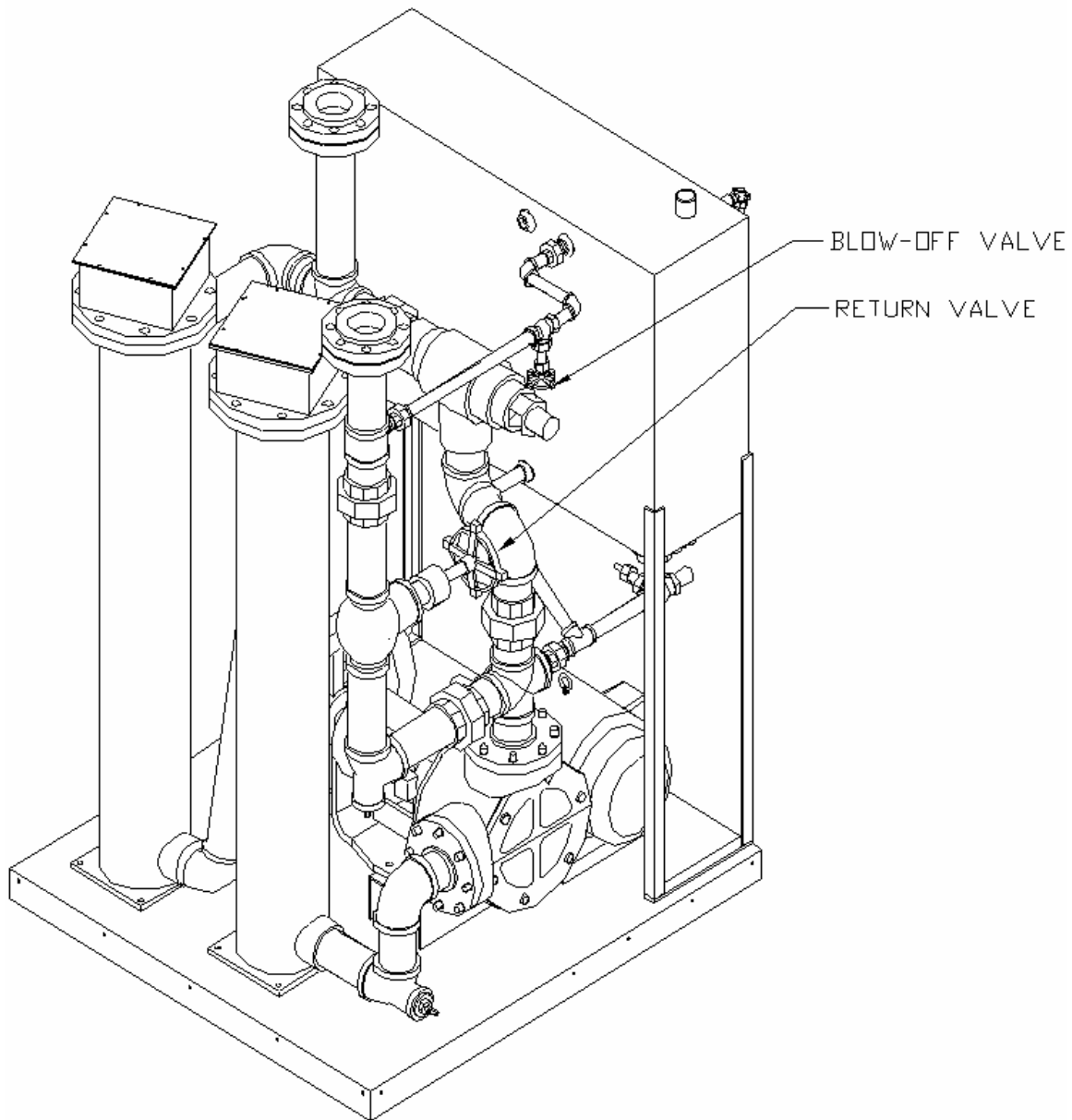

6017 Series Temperature Control Unit Specifications

| Model Number | Heaters              |        |        |        | Pump                 |         |         | Dimensions |     |     |     |     |     | Shipping Weight <sup>♣</sup> |       |
|--------------|----------------------|--------|--------|--------|----------------------|---------|---------|------------|-----|-----|-----|-----|-----|------------------------------|-------|
|              | Available capacities |        |        |        | Available capacities |         |         | H          |     | W   |     | D   |     | lbs.                         | Kg    |
| 460 / 230    | 50 kW                | 100 kW | 150 kW | 200 kW | 90 gpm               | 150 gpm | 200 gpm | in.        | cm  | in. | cm  | in. | cm  |                              |       |
| 6017-L       | ✓                    | ✓      | n/a    | n/a    | ✓                    | ✓       | n/a     | 62"        | 158 | 30" | 76  | 60" | 153 | 1,900                        | 862   |
| 6017-M       | ✓                    | ✓      | n/a    | n/a    | ✓                    | n/a     | n/a     | 62"        | 158 | 30" | 76  | 60" | 153 | 1,900                        | 862   |
| 6017-P       | ✓                    | ✓      | ✓      | ✓      | ✓                    | ✓       | ✓       | 62"        | 158 | 46" | 117 | 60" | 153 | 3,200                        | 1,452 |
| 6017-V       | ✓                    | ✓      | ✓      | ✓      | ✓                    | ✓       | ✓       | 62"        | 158 | 46" | 117 | 60" | 153 | 3,200                        | 1,452 |

♣ The actual shipping weights may vary based on options selected. The shipping weights listed are the maximum shipping weights for standard units of the listed cabinet size.



## 2

# Shipping Information

## 2-1 Unpacking and Inspection

You should inspect your Sterling/Sterlco 6017 Series hot oil large temperature control unit for possible shipping damage. If the container and packing materials are in re-usable condition, save them for reshipment if necessary.

Thoroughly check the equipment for any damage that might have occurred in transit, such as broken or loose wiring and components, loose hardware and mounting screws, etc. In case of breakage, damage, shortage, or incorrect shipment, refer to the following sections.

## 2-2 In the Event of Shipping Damages

### Important!

**According to the contract terms and conditions of the Carrier, the responsibility of the Shipper ends at the time and place of shipment.**

- Notify the transportation company's local agent if you discover damage.
- Hold the damaged goods and packing material for the examining agent's inspection. **Do not return any goods to Sterling, Inc. before the transportation company inspection and authorization.**
- File a claim against the transportation company. Substantiate the claim by referring to the agent's report. A certified copy of our invoice is available upon request. The original Bill of Lading is attached to our original invoice. If the shipment was prepaid, write us for a receipted transportation bill.
- Advise Sterling, Inc. regarding your wish for assistance and to obtain an RGA (return goods authorization) number.

## 2-3 If the Shipment is Not Complete

Check the packing list. The apparent shortage may be intentional. Back-ordered items are noted on the packing list. You should have:

- 6017 Series hot oil large temperature control unit
- Bill of lading
- Packing list
- Operating and Installation packet
- Electrical schematic and panel layout drawings
- Component instruction manuals

Re-inspect the container and packing material to see if you missed any smaller items during unpacking. Determine that the item was not inadvertently taken from the area before you checked in the shipment. Notify Sterling, Inc. immediately of the shortage.

## 2-4 If the Shipment is Not Correct

If the shipment is not what you ordered, **contact the parts and services department immediately** at [262] 641-8610. Have item and order numbers ready. *Hold the items until you receive shipping instructions.*

## 2-5 Returns

### **Important!**

**Do not return any damaged or incorrect items until you receive shipping instructions from Sterling, Inc.**

### 3-1 Work Rules

The installation, operation, and maintenance of this equipment must be conducted in accordance with all applicable work and safety codes for the installation location. This may include, but is not limited to OSHA, NEC, CSA, and any other local, national, and international regulations.

- Read and follow these instructions when installing, operating, and maintaining this equipment. If the instructions become damaged or unreadable, obtain additional copies from Sterling/Sterlco.
- Only qualified personnel familiar with this equipment should work on or with this hot oil temperature control unit.
- Work with approved tools and devices.
- Disconnect the electricity **before** maintenance or service. If the unit is installed with a power cord that can be unplugged, unplug it. If the unit is permanently wired to a power main, make sure that a fused power disconnect is installed to allow the disconnect to be locked in the **OFF** position. Open and lock out the disconnect installed in the control enclosure.

### 3-2 Installation Requirements

Make sure that you meet the following requirements when installing and operating your 6017 hot oil temperature control unit.

#### Installation Location Considerations

Locate the 6017 unit as close as possible to the process for proper circulation and temperature control. Take care when selecting a location. The area surrounding the unit must be free of obstructions to ensure proper ventilation of internal components. **Allow a minimum clearance of at least 30 inches (76 cm).**

Make sure that the unit location is not in a confined space to ensure proper air circulation. Special air circulation/ventilation is required for units operating at temperatures exceeding 500°F (260°C). Vapors can escape from areas such as the reservoir tank during high temperature operation.

**! CAUTION**



**Harmful vapors may be generated from thermal fluid during high temperature operation.**

**Prolonged or repeated exposure of these hot-generated vapors may result in eye and respiratory tract irritation.**

**Avoid contact or inhaling harmful amounts of material. Consult the Material Safety Data Sheet (MSDS) for precautions and instructions for the thermal fluid you are using.**

*Note:* Before storing your 6017 temperature control unit, make sure you remove all residual water with compressed air to avoid a potential freezing hazard.

Note the following table of ambient temperature ranges permitted for storage and operation:

| Ambient storage range |               | Ambient operation range |               |
|-----------------------|---------------|-------------------------|---------------|
| °F                    | °C            | °F                      | °C            |
| -40°F to 185°F        | -40°C to 85°C | -4°F to 120°F           | -20°C to 49°C |

You should preheat the process heat transfer fluid first if you want to start the unit below an ambient temperature of 30°F (-1°C).

### 3-3 Connecting Piping

Make sure that all external piping is properly sized to reduce external pressure drop as much as possible. Do not install process or water supply/drain piping smaller than the fittings on the unit. If the water supply piping is larger than unit fittings, reduce the pipe size at the unit.

The following table lists 6017 TCU pipe sizes.

Connections for **TO PROCESS** and **FROM PROCESS** lines are:

- 2" NPT (50.8 mm) at 90 gpm (341 lpm)
- 2-1/2" NPT (63.5 mm) at 150 gpm (568 lpm)
- 3" NPT (76.2 mm) at 200 gpm (757 lpm)

Water connections for **COOLING WATER SUPPLY** and **COOLING WATER DRAIN** are:

- 3/4" NPT (19.1 mm) for 3.9 & 6.7 sq. ft. heat exchangers.
- 1" NPT (25.4 mm) for 13, 21, & 27 sq. ft. heat exchangers.

*The customer is responsible for conversions to metric standards.*

**Notes:** Always use a backup wrench to support 6017 unit piping when making connections. Make sure all external piping is supported **independently** of the 6017 unit.

Sterling, Inc. recommends that you have strainers installed on the cooling water inlets and customer-supplied shut-off valves on all piping connections. Use common black welded pipe for permanent installations.

The 6017 is designed to operate with an open, unrestricted drain line. Steam rapidly expands within the heat exchanger, so any overpressure condition from backpressure or standing columns of water against the drain **must be avoided**.

If you must use a pipe joint compound, use a compound that can withstand the high temperatures and pressures of your 6017 unit. Always insulate all piping to prevent burn hazards and to retain heat. Make sure insulation is properly rated for maximum operating temperatures of your 6017 unit.

## Piping Considerations for Mobile Installations

Because your 6017 unit is not fitted with casters, it should be secured to the floor with the appropriate hardware. You can purchase high-quality flexible metal hose from Sterling/Sterlco to allow for thermal expansion of the process piping; state the length you want when ordering.

## Connecting Process Piping

### **! CAUTION**

- Hoses, valves and other components in your process must be able to withstand the 6017 unit's maximum temperatures and pressures.
- Maximum temperatures and pressures are listed on the unit nameplate.
- Carefully inspect all components before installation.
- If in doubt about component suitability, obtain factory components.
- Fix all leaks! Fluid can be a potential fire and slip hazard.
- Never open pipe insulation that is smoking! Adding oxygen can cause a fire.

## Connecting Cooling Water Piping

You must provide cooling water at 25 psi to 75 psi (172.4 kPa to 517.1 kPa/1.7 bars to 5.2 bars) for proper operation. Untreated water can foul or corrode the heat transfer surfaces, slowing water flow and causing fluid temperature control problems. Sterling, Inc. sells a complete line of water treatment equipment that can reduce downtime and maintenance costs.

Run properly-sized cooling water lines-never smaller than the outlets on the 6017 unit. If external piping is larger than 6017 unit connections, reduce the size of the piping at the unit.

## Connecting Vent Piping

**You must leave the vent connection open to the atmosphere at all times.** The vent connection is located on top of the reservoir. On systems with piping above the reservoir level, you **must** run vent piping to a minimum height of one foot (1' / 31 cm) above the highest point in the system. Run the piping down into an auxiliary vented overflow chamber, such as a vented, *covered* 55-gallon (208-liter) drum. This practice ensures that overflow will not create a hazard to personnel.

**Remember:** All external piping must be supported independently of the 6017 unit.

## **! CAUTION**

**The reservoir tank must be vented to prevent pressurization. A pressurized reservoir could rupture, allowing hot fluid to escape and become a potential fire and slip hazard.**

*Note:* Heat transfer fluids expand when heated. Expansion rates vary, depending on fluid types and temperatures. For more information on expansion rates, refer to specification information for the heat transfer fluid you select.

Generally, most heat transfer fluids expand at the rate of 2.5% for every increase of 50°F from temperatures above 60°F (16°C).

Connect the **TO PROCESS** hookup to the entrance of the process and the **FROM PROCESS** hookup to the exit of the process. Connect the **COOLING WATER SUPPLY** to your plant water supply. Connect the **COOLING WATER DRAIN** line to an open drain, or to the return line of your central water system. If returning to a central water system, use a condensate/return tank to avoid a standing water column on the heat exchanger drain line.

## **! CAUTION**

**If you are routing the drain line to an open drain, make sure that the line is directed away from personnel to avoid scalding.**

**Carefully select connecting lines and connectors between the 6017 unit and the process to best meet the needs and requirements of your application.**

**Make sure lines and connectors have a service rating of at least 100 psig (689.5 kPa/6.9 bars), and a temperature rating at least equal to the maximum operating temperature of your 6017 unit.**

Figure 3  
Typical Flow Schematic

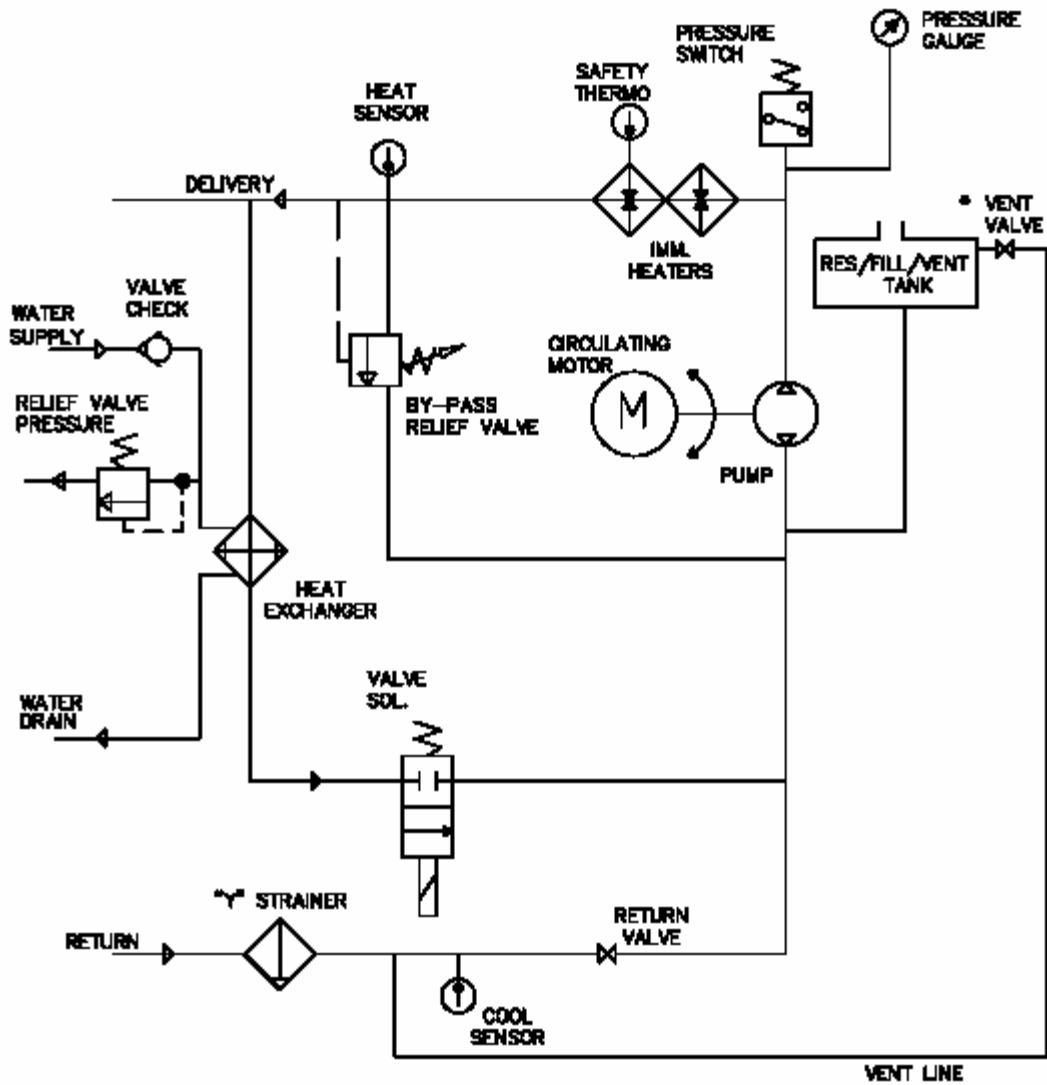

Note: The heat exchanger is optional, and the "Vent Valve" is also known as the "Blow-Off Valve."

- Vent Valve - open for purge/closed for run/open for pump reverse.
- Return Valve - closed for purge/ open for run/ closed for pump reverse.
- Reservoir Tank - Open to atmosphere at all times, unless nitrogen blanket provisions are present.



Figure 4  
Custom Process Piping

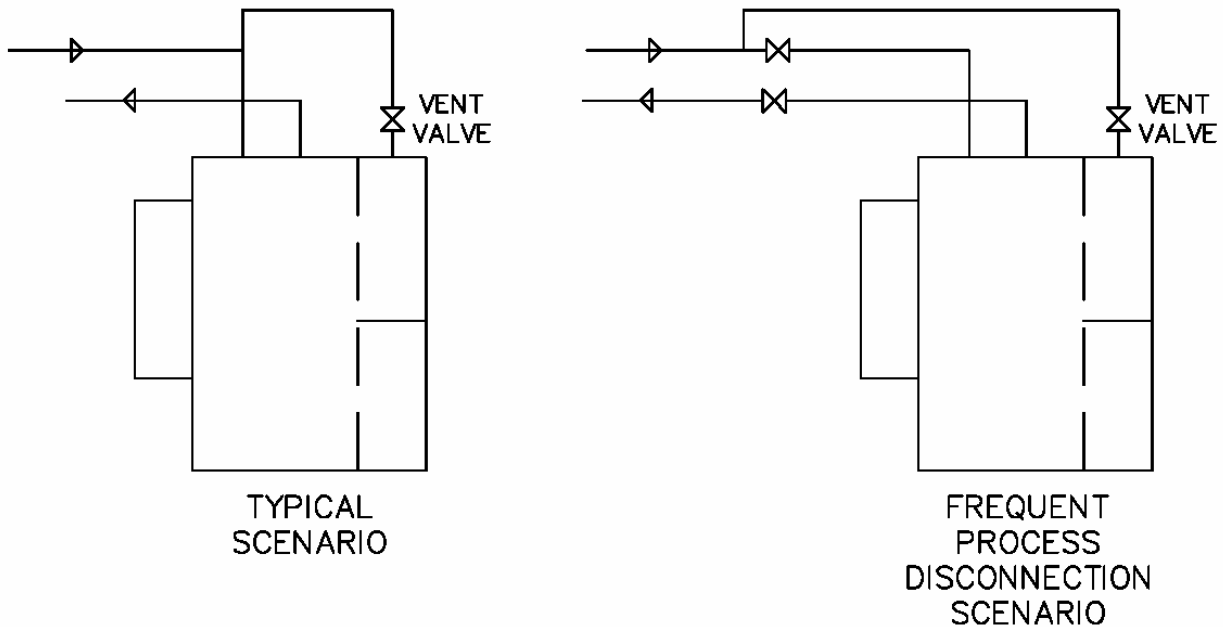

The optimum location for venting is on the top of the overhead return piping above the unit. The customer is encouraged to add an extra vent (Blow-Off) valve at this point. With this new Blow-Off Valve location the return valve and internal blow-off valve should be closed completely during venting. Otherwise air could be pulled into the piping by gravity instead of being removed.

The frequent process disconnection scenario has the vent line connected to the process side of the two isolation valves. This allows the disconnected process to be vented without contaminating the rest of the piping and unit to be contaminated with air. This is accomplished by the following steps once the process is reconnected to the unit and the isolation valves are still closed.

Note: during this process the internal blow-off valve is closed and the return valve can be open.

- 1.) Open the external vent valve.
- 2.) Open the isolation valve that is delivering oil to the process from the unit. Leave the isolation valve that is returning the oil from the process to the unit closed.
- 3.) Wait for all of the process to fill with heat transfer fluid and push the air and back to the reservoir.
- 4.) Once all of the air has been replaced with fluid, and only oil is being dumped into the reservoir; close the vent valve.
- 5.) Open the isolation valve that is returning the oil from the process.

## 3-4 Making Electrical Connections

These units are designed for three-phase voltage operation. Refer to the unit nameplate for proper voltage and amperage requirements, and make sure your electrical service conforms.

**Check the unit nameplate for correct voltage and amperage *before* making electrical connections!**

### **! CAUTION**

1. Provide a correctly sized and protected power supply to the unit.
2. If an electrical supply disconnect is not installed as a factory option, the customer is responsible to properly size and install a suitable disconnect.
3. Refer to National Electric Code (NEC) 430-24-26 for proper feed conductor and supply disconnect sizing.
4. Voltages must be within plus or minus ten percent ( $\pm 10\%$ ) of the nameplate rating.
5. Maintain a safe ground and disconnect the power supply before servicing the unit.

**A qualified electrician should make electrical connections and disconnect the electricity when service calls are needed.**

- Locate disconnects in an **easily accessible location**. Operators should not have to squeeze around the 6017 unit to reach disconnects, especially in case of emergency.
- When running conduit whips to the 6017 unit, make sure that whips are routed away from hot piping.

Check the unit nameplate for correct voltage and amperage *before* making electrical connections!

# ! DANGER



**IMPROPER ELECTRICAL CONNECTIONS CAN DAMAGE THE UNIT AND CAUSE SERIOUS OPERATOR INJURY OR DEATH!**

**MAKE SURE THAT ALL ELECTRICAL CONNECTIONS ARE MADE BY A QUALIFIED ELECTRICIAN, AND THAT ALL CONNECTIONS ARE TIGHT.**

Make all electrical supply connections at the front of the unit. An access panel covers all electrical connections. Run electrical connections to the supply terminals from either side of the unit. Make sure that all three phases are wired correctly. *The pump runs backwards if not wired properly.*

- Notes -

## 4-1 Starting the Unit

### UNIT START-UP (WITH MANUAL BLOW-OFF VALVE)

The highly engineered controls and controller make this unit almost self operating. Before you can begin heating, it will be necessary to perform the following start up procedures. This will ensure that all air is vented from the system to prevent fluid degradation and damage to the heater.

1. Open the Return Valve and the Blow-Off Valve. Make sure the drain valves are closed and plugged.
2. Add fluid to the reservoir tank until the level is near the top of the sight glass.
3. Close the Return Valve inside the unit.
4. Depress the "Pump Start" button to start the pump. Check motor rotation by observing the pressure gauge. If the gauge indicates positive pressure, rotation is correct. If not, disconnect power and reverse the incoming power leads.
5. As fluid is drawn out of the reservoir tank to fill the process, the fluid level will fall in the tank. Continue to add fluid to maintain the level about 4 inches from the bottom of the sight glass.

### **! CAUTION**

**You must purge the system of air before the heating cycle.  
Personal injury and system damage can occur from a pressurized system.**

6. Air and Oil will be vented through the Blow-Off Valve and into the reservoir tank.
7. After the unit stops requiring more oil and has at least 5 psi of pressure, open the Return Valve half way.
8. Once the unit has stopped requiring more oil again and has at least 10 psi of pressure, select a set point of 100°F (38°C) and switch unit into the "Auto" mode. As the oil warms up, viscosity will decrease, and the pressure will fall.
9. In 2-minute intervals increase the setpoint to 150°F (66°C) and 200°F (93°C).

10. If any water is present in the system, it must be boiled off before continuing operation. Select a setpoint of 215°F (102°C) and observe the reservoir tank vent for any signs of escaping steam. Continue to run at 215°F (102°C) until no more steam appears and pressure has stabilized.
11. When fluid level has stabilized and air and water are purged from the system, open the Return Valve all the way. And select a setpoint of 250°F (121°C).
12. If the fluid level and pressure remain stable close the Blow-Off Valve. Do not open the Blow-Off Valve above 250°F.

With the system properly purged, only 4 - 6" of fluid should be visible in the sight glass. This will allow for expansion of the fluid as it heats, as well as capacity for process fluid when the pump is reversed and fluid withdrawn from the mold.

The 6017 is now ready for use. All that is required is to select a process set point on the controller as described in the controller manual.

NOTE: If all traces of water are not removed from the system, severe cavitation may occur at elevated temperatures. Indications are a "gravely" sounding pump, fluctuating or dropping pressure, or rapidly rising fluid level in the expansion tank. Repeat Steps #9-12 if this occurs.

#### **UNIT START-UP (WITH AUTOVENT SOLENOID)**

The highly engineered controls and controller make this unit almost self operating. Before you can begin heating, it will be necessary to perform the following start up procedures. This will ensure that all air is vented from the system to prevent fluid degradation and damage to the heater. The autovent solenoid operates just like the manual Blow-Off valve, however it opens electrically and for only a specified time. The benefit is that it vents every time the unit is started and it will automatically shut off after a predetermined amount of time. It is also convenient, because the vent button is located on the front of the unit. It has the added safety of being automatically prevented from opening above 250°F by a safety thermostat.

1. Open the Return Valve. Make sure the drain valves are closed and plugged.
2. Add fluid to the reservoir tank until the level is near the top of the sight glass.
3. Depress the "Pump Start" button to start the pump. Check motor rotation by observing the pressure gauge. If the gauge indicates positive pressure, rotation is correct. If not, disconnect power and reverse the incoming power leads.
4. Close the Return Valve inside the unit.
5. As fluid is drawn out of the reservoir tank to fill the process, the fluid level will fall in the tank. Continue to add fluid to maintain the level about 4 inches from the bottom of the sight glass.

## **! CAUTION**

**You must purge the system of air before the heating cycle.  
Personal injury and system damage can occur from a pressurized system.**

6. Air and Oil will be vented through the automatic Blow-Off Valve and into the reservoir tank.
7. After the unit stops requiring more oil and has at least 5 psi of pressure, open the Return Valve half way. If the Blow-Off cycle times out, start the sequence again. The timer is factory set at 5 minutes. A longer time can be set if required. The first time the unit is filled with oil it takes some time to vent out the air. You should determine how long is appropriate for venting on a regular basis when the unit is already full.
8. Once the unit has stopped requiring more oil again and has at least 10 psi of pressure, select a set point of 100°F (38°C) and switch unit into the "Auto" mode. As the oil warms up, viscosity will decrease, and the pressure will fall.
9. In 2-minute intervals increase the setpoint to 150°F (66°C) and 200°F (93°C).
10. If any water is present in the system, it must be boiled off before continuing operation. Select a setpoint of 215°F (102°C) and observe the reservoir tank vent for any signs of escaping steam. Continue to run at 215°F (102°C) until no more steam appears and pressure has stabilized. Restart the Blow Off cycle as necessary if it times out.
11. When fluid level has stabilized and air and water are purged from the system, open the Return Valve all the way. And select a setpoint of 250°F (121°C). Restart the Blow Off cycle as necessary if it times out.
12. If the fluid level and pressure remain stable allow the Blow-Off Valve to close. The vent valve will not open the Blow-Off above 250°F.

With the system properly purged, only 4 - 6" of fluid should be visible in the sight glass. This will allow for expansion of the fluid as it heats, as well as capacity for process fluid when the pump is reversed and fluid withdrawn from the mold.

The 6017 is now ready for use. All that is required is to select a process set point on the controller as described in the controller manual.

**NOTE:** If all traces of water are not removed from the system, severe cavitation may occur at elevated temperatures. Indications are a "gravely" sounding pump, fluctuating or dropping pressure, or rapidly rising fluid level in the expansion tank. Repeat Steps #9-12 if this occurs.

## 4-2 Shutting Down the Unit

### UNIT SHUT DOWN (WITH AUTOVENT SOLENOID OR MANUAL VENT VALVE)

Cool the unit down by switching the **Mode** switch to the "Manual Cool" position. This will disable the heaters ( i.e. prevent the controller from turning them on) and open the cool solenoid. Fluid temperature can be monitored on the controller display during cool down. When fluid temperature is below 120°F, depress the **PUMP STOP** button to turn the unit off.

## 4-3 Returning Fluid to the Tank

### RETURNING FLUID TO TANK

If the unit is to be moved from one process to another (i.e. mold changes, etc.), the following steps must be taken to drain the mold and process lines. Note that this is just the opposite of unit start up/air purge:

1. Cool fluid to 150°F (66°C) maximum.
2. Depress the **PUMP STOP** push button.
3. Close the Return Valve.
4. Open the Blow Off Valve. (with autovent, the valve will open on its own)
5. Depress and hold the **PUMP REVERSE** push-button. The pump will then run in reverse, drawing fluid from the mold and lines, and into the reservoir tank.
6. Watch the sight glass to prevent overflow of the reservoir tank.

### **! CAUTION**

**The reservoir tank may not have adequate volume to contain the total system capacity of fluid.**

**An overflowing reservoir allows hot fluid to escape and become a potential fire and slip hazard.**

**The total capacity of the tank can be found on page 14.**

If it appears that the tank may overflow, connect a line from the **FILL** port of the reservoir tank to a **clean** auxiliary container.



**- Notes -**

# 5

## Using Controls and Indicators

### 5-1 The Microprocessor Controller

The M2B controller is an easy-to-operate microprocessor-based PID control device. When the process reaches the set point, the PID control cycles the cooling valve and/or immersion heater to maintain the proper leaving fluid temperature.

The controller is fully factory tested. Set the process temperature set point you want and the controller does the rest.

Built-in range of operation on the controller is 0°F to 550°F (-18°C to 288°C).

Figure 4  
Typical M2B Graphic and Button Control Panel

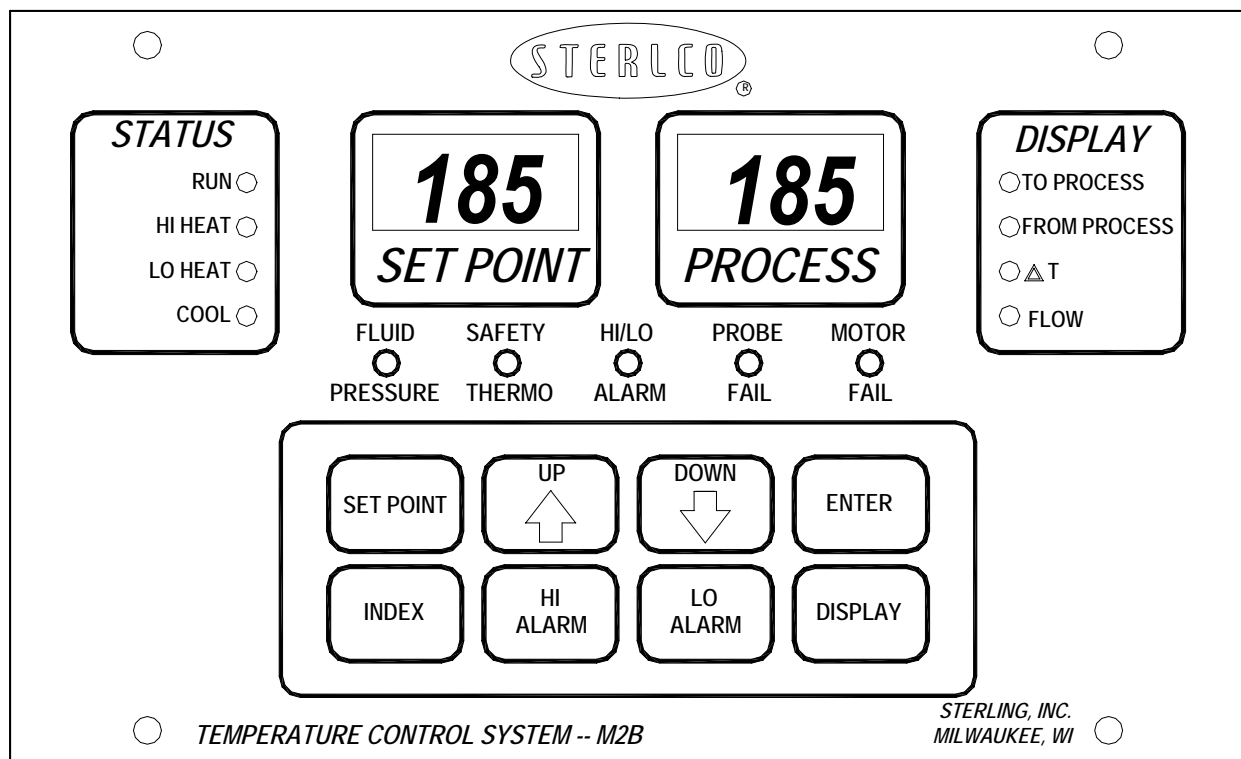

## 5-2 Identifying M2B Controller Panel Components

### Screen Displays

#### SET POINT Numeric LED

During normal operation, the **SET POINT** LED on the controller displays the process set point you want the unit to maintain. It also displays parameter and pre-set function values during setup.

#### PROCESS Numeric LED

During normal operation, the **PROCESS** LED on the controller displays the actual process temperature at the To Process thermocouple. It also lists parameter symbols during setup and error messages if an error occurs.

### Status Indicators

#### RUN Indicator

The **RUN** indicator is on during normal operation and flashes during the auto-tuning sequence.

#### HI HEAT Indicator

The **HI HEAT** indicator is on when fluid heaters are at 100% capacity to rapidly raise fluid temperature.

#### LO HEAT Indicator

The **LO HEAT** indicator is on when fluid heaters are at 50 percent capacity.

#### COOL Indicator

The **COOL** indicator is on when fluid temperature is above the set point and is being cooled.

### Display Indicators

#### TO PROCESS Indicator

The **TO PROCESS** indicator is on when the **PROCESS** LED screen on the controller displays the temperature of the outgoing fluid.

## FROM PROCESS Indicator

The **FROM PROCESS** indicator is on when the **PROCESS** LED screen on the controller displays the temperature of the incoming fluid.

## $\Delta T$ Indicator

The  $\Delta T$  indicator is on when the **PROCESS** LED screen on the controller displays the difference in temperature between outgoing Delivery fluid and incoming Return fluid.

## FLOW Indicator

The **FLOW** indicator is on when the **PROCESS** LED screen on the controller displays the flow of fluid in liters per minute; this function requires the optional flow sensor.

## Alarm Indicators

### FLUID PRESSURE Indicator

The **FLUID PRESSURE** indicator goes on when fluid pressure is low. The TCU shuts down and resumes operation only when a proper level of fluid pressure is restored.

### SAFETY THERMO Indicator

The **SAFETY THERMO** indicator is on when an over-temperature condition occurs. The heater outputs are then disabled, the pump continues to operate, and the **COOL** solenoid energizes. This is a **fatal fault condition**, requiring that main power be disconnected to reset the M2B controller.

### HI/LO ALARM Indicator

The **HI/LO ALARM** indicator is on when an individually-set alarm condition occurs. The **HI** deviation is +200°F (about +93°C) above the set point. The **LO** deviation is -100°F (about -37°C) below the set point. **Alarms reset automatically.**

### PROBE FAIL Indicator

The **PROBE FAIL** indicator is on when a temperature sensing probe fails. A delivery probe failure displays **DEL** on the screen, and a return probe failure displays **RET** on the screen. The alarm resets after the failed probe is replaced.



## MOTOR FAIL Indicator

The **MOTOR FAIL** indicator is on during improper pump rotation, motor out of phase, or thermal motor overload conditions. This is a **fatal fault condition**, requiring that main power be disconnected to reset the M2B controller.

## 5-3 Using M2B Controller Keys



### SET POINT Key

Press and hold the  **SET POINT** key, then press the  **UP Arrow** key to increase the set point value or press the  **DOWN Arrow** key to decrease the set point value displayed on the **SET POINT** LED screen.



### UP Arrow Key

Press the  **UP Arrow** key to increment or advance the values or settings on the LED screens.



### DOWN Arrow Key



Press the  **DOWN Arrow** key to decrement or reduce the values or settings on the LED screens.

### Important!

**Do not change any of the control settings  
without consulting the Sterling/Sterlco Service Department.**

***The Sterling, Inc. warranty does not cover TCU failures  
from tampering with controller settings!***



 **ENTER Key**

The  **ENTER** key is used with the  **INDEX** key menu to store the value or the item that was changed. If this key is not pressed, the previously-stored value or item is retained.



 **INDEX Key**

Each press of the  **INDEX** key advances the screen to the next menu item. Refer to your Sterling/Sterlco M2B Temperature Control Owner's Manual for a list of functions available using this key.

 **HI ALARM Key**

Press and hold the  **HI ALARM** key, then press the  **UP Arrow** key to increase the alarm high limit value or press the  **DOWN Arrow** key to decrease the alarm high limit value on the **SET POINT** LED screen. Refer to your Sterling/Sterlco M2B Temperature Control Owner's Manual for a list of functions available using this key.

 **LO ALARM Key**

Press and hold the  **LO ALARM** key, then press the  **UP Arrow** key to increase the alarm low limit value or press the  **DOWN Arrow** key to decrease the alarm low limit value on the **SET POINT** LED screen. Refer to your Sterling/Sterlco M2B Temperature Control Owner's Manual for a list of functions available using this key.



## DISPLAY Key



Press the **DISPLAY** key to advance through the display menu. Each key press increments to the next available function. The screen returns to delivery temperature after thirty (30) seconds of inactivity. Refer to your Sterling/Sterlco M2B Temperature Control Owner's Manual for a list of menus available using this key.

## Digital Flow Screen

### Optional

The optional digital flow screen displays process flow in gallons per minute (gpm). No customer-usable control is necessary. Depending on option level and setup, flows can be measured at rates reaching and exceeding 75 gallons per minute (284 lpm).

## 5-4 Identifying Control Panel Switches

This section lists the descriptions and functions of the control panel switches. These switches control the operation of the unit.

Figure 5  
Control Panel Switches

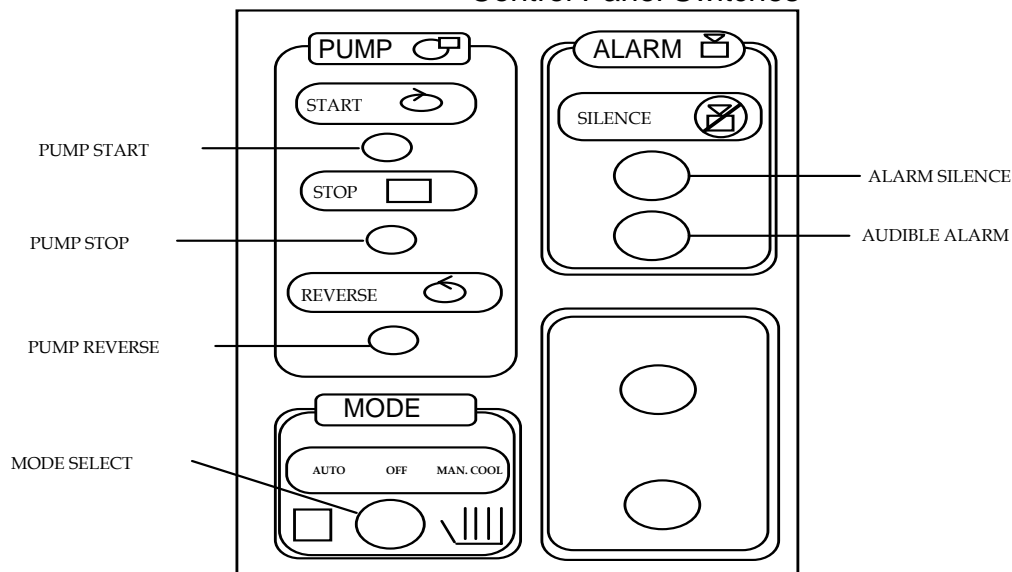

## Pump Start

Press the **START**  button to start the pump in the normal forward direction.

## Pump Stop

Press the **STOP**  button to stop the pump and de-energize the controller.

### ! CAUTION

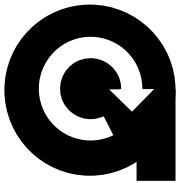

Always press the **Pump Stop**  button and allow the pump to come to a complete stop before pressing the **Pump Reverse**  button.

Failure to let the pump stop before reversing may damage the pump and drive.

## Pump Reverse

Press the **REVERSE**  button to start the pump in the reverse direction. Use this feature to purge oil from the mold.

## Vent Cycle Start (optional)

Press the **VENT**  button to start the vent cycle timer. Use this feature to purge air and water from the unit and process. This is used when the Autovent Cycle Option is added to the unit.

## Mode Select

With the pump running, you can select the **AUTO** position or the **MAN. COOL** (manual cooling) position with the **Mode Select** switch. Select **AUTO** mode to energize the controller, permitting it to monitor and control the process. The switch automatically returns to the **OFF** position when in **AUTO** mode. The switch stays in the **MAN. COOL** position in **Manual Cooling** mode.

### ! CAUTION

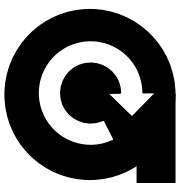

Always let the pump run for at least one (1) minute before switching to **AUTO** mode.

Never switch to **AUTO** mode when filling or venting the unit, except as described in the **Unit Startup** chapter. Improper switching can seriously damage the heater, as it could become energized with air in the system.



## Alarm Silence

Press the **ALARM SILENCE**  button to silence the audible alarm on the console.

**! CAUTION**

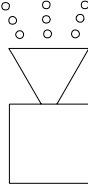

**After you silence the alarm, make sure you *locate and correct* the alarm condition before continuing with unit operation.**

## 5-5 Identifying System Status Board Indicators

The system status board is located next to the controller panel. It displays indicator lights to show current operation status, letting you analyze system performance.

Figure 6  
System Status Board Indicators

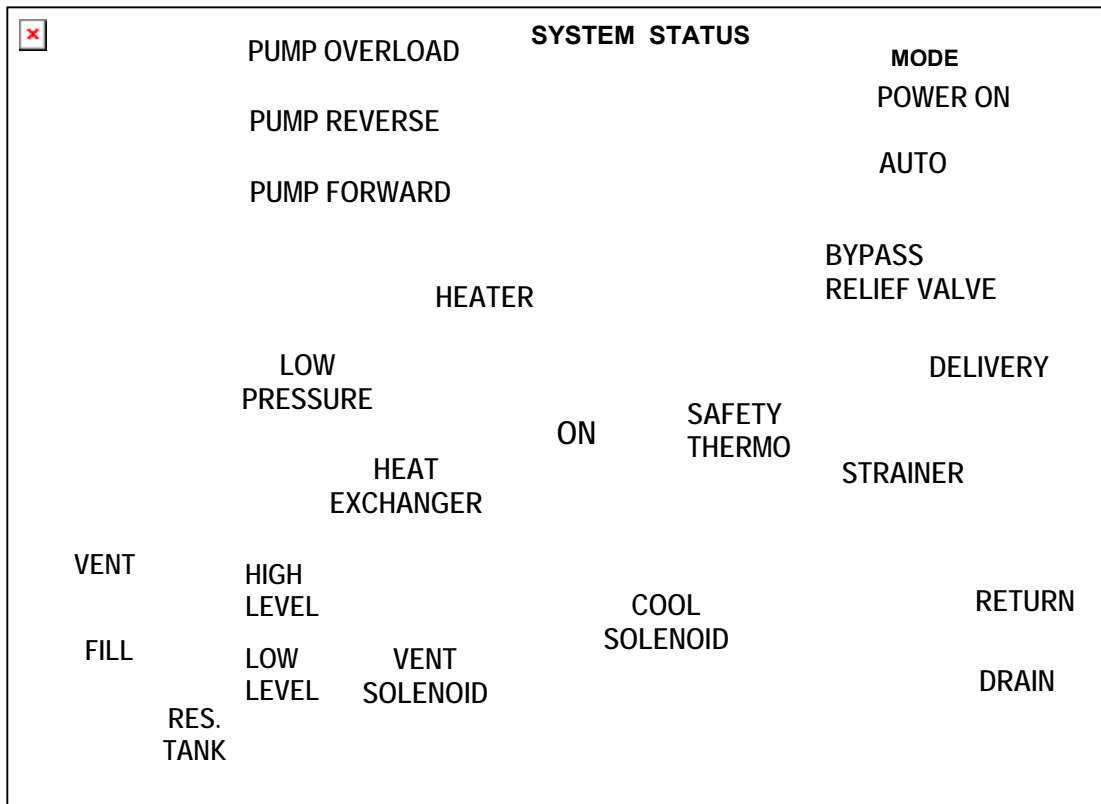

Use the status board to optimize unit performance. For example, if you observe a rapid cycling of the **Heater** and **Cool Solenoid** indicators, the unit is operating with a process inefficiency; see the Troubleshooting chapter for more information.

What follows is a description of system status board indicators.

## Status Indicator Lights

### Pump Reverse Indicator Light

The **Pump Reverse** indicator light illuminates when the unit pump runs in reverse.

### Pump Forward Indicator Light

The **Pump Forward** indicator light illuminates when the unit pump runs in the normal forward direction. This indicator typically illuminates continuously during normal operation.

### Heater On Indicator Light

The **Heater On** indicator illuminates when the heater energizes. This indicator illuminates intermittently when the controller energizes and de-energizes the heater as the heating cycle requires.

### Cool Solenoid Indicator Light

The **Cool Solenoid** indicator illuminates when the cooling solenoid energizes. This indicator illuminates intermittently as the controller energizes the cooling solenoid; it is used only on the optional heat exchanger.

### Vent Solenoid Indicator Light

If the Autovent option is present. The **Vent Solenoid** indicator illuminates when the venting solenoid energizes during venting sequences.

## Mode Indicator Lights

Select the unit operating mode by using the **selection switch**.

### Power On Mode Indicator Light

The **Power On** mode indicator light illuminates to indicate that the control circuit is energized in the unit.

## Auto Mode Indicator Light

The **Auto** mode indicator light indicates that the Auto mode is active and the controller is monitoring the system and controlling the process.

If the **Auto** light is off and the **Cool Solenoid** indicator light is illuminated, the controller is disabled and the cooling solenoid is open, permitting maximum cooling.

If the **Auto** and **Cool Solenoid** indicator lights are off, the unit is in standby.

## Fault Indicator Lights

### Pump Overload Indicator Light

The **Pump Overload** indicator light illuminates when the pump is overloaded. *This is an alarm condition*, so the audible alarm activates to notify you of the pump overload fault, and the unit shuts down.

**Always correct the alarm condition before returning to normal operation!**

### Low Pressure Indicator Light

The **Low Pressure** indicator light illuminates when the unit has low heat transfer fluid pressure. *This is an alarm condition*, so the audible alarm activates to notify you of the low pressure fault, and disables controller outputs, permitting the pump to continue to circulate fluid to avoid damage. If low pressure continues past five minutes elapsed time, the pump shuts off.

**Always correct the alarm condition before returning to normal operation!**

### Safety Thermo Indicator Light

The **Safety Thermo** indicator light illuminates when the unit is overheating. *This is an alarm condition*, so the audible alarm activates to notify you of the safety thermo fault, and disables controller outputs, permitting the pump to continue to circulate fluid to avoid damage.

**Always correct this alarm condition before returning to normal operation!**

### **High Level Indicator Light**

The high fluid level alarm is an available option. The **High Level** indicator light illuminates when the heat transfer fluid level in the reservoir tank is **too high**. Carefully remove just enough fluid so this indicator light shuts off and an adequate volume is maintained in the reservoir.

### **Low Level Indicator Light**

The low fluid level alarm is an available option. The **Low Level** indicator light illuminates when the heat transfer fluid level in the system is too low. ***This is an alarm condition***, so the audible alarm activates to notify you of the low fluid level fault, and the controller outputs are disabled.

**Always correct the alarm condition before returning to normal operation!**

**- Notes -**

## ! WARNING

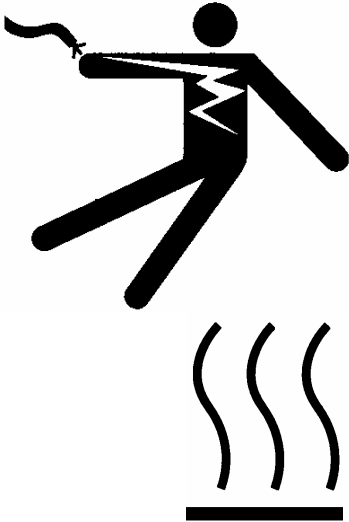

**Make sure that your maintenance technicians comply with lock-out/tag-out procedures during any servicing or maintenance of this unit and related equipment, per OSHA article ART 1910.147.**

***Before you begin servicing this unit, disconnect all power to the unit, let the unit cool down completely, and turn off the water.***

**Failure to follow these directives can result in serious injury or *death!***

## 6-1 Periodic Checks

### Making Daily Checks

- Check fluid level; *add fluid as needed.*
- Check all connecting lines, hoses, and connectors for wear or damage.

### Making Monthly Checks

- Check for leaks developing at the pump seal, gaskets, and other similar locations.
- Check the pump drive V belt for any wear.
- Check the reservoir tank vent for any obstructions.

## Making Quarterly Checks

- Check the heat transfer fluid for deterioration. If the fluid is noticeably darker, or it seems significantly thicker, drain the system and replace the fluid with fresh, new recommended heat transfer fluid.

Do a routine check of the fluid every 1,000 hours of operation or every three (3) months, whichever comes first. Contact Sterling, Inc. Service for information on fluid testing.

## Making Six-Month Checks

- Inspect electrical connections for secure, tight attachment points and ground connections. Inspect the power cable, especially at the entrance point to the electrical enclosure. Have a qualified electrician perform this inspection.
- Check the mounting bolts on the pump, the motor, and the heater flange for tightness.
- Remove the heat exchanger tube bundle and check it for lime and mineral deposits. Carefully clean the bundle as needed.

## 6-2 Routine Servicing

Your hot oil temperature control unit requires little in preventive maintenance and servicing. To keep it in good, reliable working order, make sure you follow the following scheduled preventive maintenance procedures.

Keep surfaces clean and free of any excessive accumulations of dirt, oil, or debris. This is especially true for the pump. It relies on free air circulation for proper cooling.

Check the motor air intake screen for any accumulation of dirt; clean it as needed.

## Servicing the Unit Monthly or Every 500 Hours

- **Lubricate the pump** at the grease fittings with a high-quality polyurea grease rated at 320°F or higher. Recommended: Chevron Black Pearl; *do not over-lubricate*.
- **Adjust the pump drive belt tension.** Use the belt tensioning specifications listed in this chapter on ***Page 51***. Make sure that the motor pulley is properly aligned with the pump pulley; use a straightedge to check. Tighten motor mounting bolts after realignment.
- Inspect the screen in the Y strainer for accumulations of debris. Clean as needed.

## Servicing the Unit Every Three Months

Remove and clean the screen in the Y-strainer. Replace the screen if it is damaged.



## Motor Lubrication Procedure

Be sure that the grease you are adding to the motor is compatible with the grease already in the motor. Consult your Baldor distributor or an authorized service center if a grease other than the recommended type is to be used.

A high grade ball or roller bearing grease should be used. Recommended grease for standard service conditions is Polyrex EM (Exxon Mobil).

Equivalent and compatible greases include:

Texaco Polystar, Rykon Premium #2, Pennzoil Pen 2 Lube and Chevron SRI.

| 1800 RPM<br>motor size | Lubrication Intervals in Hours |               |            | Grease to be added |       |         |
|------------------------|--------------------------------|---------------|------------|--------------------|-------|---------|
|                        | up to 250°F                    | 251°F - 400°F | over 400°F | ounces             | grams | cu. In. |
| 5 HP and Under         | 12,000                         | 6,000         | 1,200      | 0.30               | 8.4   | 0.6     |
| 7-1/2 to 20 HP         | 10,000                         | 5,000         | 1,000      | 0.61               | 17.0  | 1.2     |
| 25 - 40 HP             | 8,000                          | 4,000         | 750        | 0.81               | 23.0  | 1.5     |

**Caution:** To avoid damage to motor bearings, grease must be kept free of dirt. For an extremely dirty environment, contact your Baldor distributor or an authorized Baldor Service Center for additional information.

### With Grease Outlet Plug

1. Clean all grease fittings.
2. Remove grease outlet plug.
3. If motor is stopped, add the recommended amount of grease. If motor is to be greased while running, a slightly greater quantity of grease will have to be added. Add grease slowly until new grease appears at shaft hole in the endplate or purge outlet plug.
4. Re-install grease outlet plug.

### Without Grease Outlet Plug

1. Disassemble motor.
2. Add recommended amount of grease to bearing and bearing cavity. (Bearing should be about 1/3 full of grease and outboard bearing cavity should be about 1/2 full of grease.)  
Note: Bearing is 1/3 full when only one side of bearing is completely full of grease.
3. Assemble motor.

### 6-3 Draining the Unit for Storage

You should thoroughly flush and drain the 6017 unit if you need to take it out of service for a long time, or if you expect it to become exposed to freezing temperatures. Sterling, Inc. recommends SterlFlush™ flushing fluid or equivalent for flushing your 6017 unit; follow unit flushing instructions that comes with SterlFlush™ flushing fluid.

Drain plugs are provided at the base of the heater tank, reservoir tank, and on the pump. You should also remove, drain, and reinstall the heat exchanger tube bundle before storage.

## 6-4 Corrective Maintenance

### Pumps and Seals

Each 6017 unit is completely tested and calibrated before leaving the factory. The unit is then cooled, drained, and packed for shipment.

If the unit stands idle for a long time before being installed in your factory, gaskets can dry out and possibly leak when you start the unit. In most cases, these gaskets soon swell and form a tight seal. If not, **you may need to tighten the bolts to stop the leak.**

Similarly, rough handling in shipping may sometimes cause minor leaks upon startup; **you may need to re-tighten bolts or fittings to stop the leak.**

You should expect to periodically adjust the packing or replace the pump seal. If the pump is properly lubricated and used at moderate temperatures, the seal should last several years. The following section describes the proper procedures for replacing the seal. Periodic replacement of the pump drive V-belt is also to be expected.

**Note:** If the pump motor wiring is disconnected for removal from the unit, **you must check the actual direction of rotation** when the motor is rewired to the unit.

## How to increase Belt Life

### Keep sheaves and belts clean.

Abrasive dust, rust, oil and acids reduce service life.



### Give drives elbow room.

Never let belts run against belt guards or other obstructions.



### Use large diameter sheaves and fewer belts.

You save money and increase drive life.



### Never force belts.

Move motor on adjustable base so belts can go on easily.



### Eliminate slack.

Adjust motor and tighten belts in position. Slack belts wear excessively, cause slippage and deliver less power.



### Use matched belts.

Matched belts run smoother and last longer because the load is evenly distributed. Never replace just part of a set of belts.



### Avoid belt idlers.

Belt idlers decrease belt life! Always maintain proper tension through motor adjustment.



### Mount belts straight.

Shafts must be parallel and sheave grooves in alignment to prevent unnecessary belt wear.

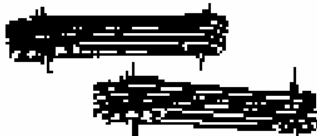

### Don't overload.

An overloaded belt drive is like a one-ton truck with a two-ton load — both are sure to break down. Always use ample capacity.



### ⚠ WARNING

Operating drives without guards in place can result in severe injury or death.

# Browning®

## BELT TENSIONING INSTRUCTIONS



### ⚠ WARNING

Disconnect power before installation and maintenance. Failure to do so can result in severe injury or death.

1. Measure the belt span.
2. Calculate deflection
3. See tables below for correct deflection force.
4. Apply force at right angles to the center of the span (see diagram below). The BROWNING® belt tension checker, shown at left, is ideal for this procedure.
5. Check the tension at least twice during the first day of operation, and periodically thereafter.

Be sure — use the inexpensive **BROWNING® Belt Tension Checker** See Form 5453 for more detail.

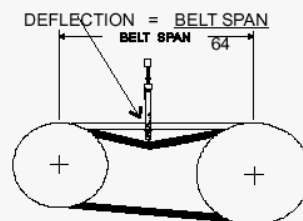

The capacity of the BROWNING® belt tension checker is 35 lbs. Other means of applying force must be used if force requirement is greater than this.

### SHEAVE DIAM - INCHES DEFLECTION FORCE - LBS.

| Belt Cross Section | Smallest Sheave Diameter Range | RPM Range                          | Belt Deflection Force                   |              |                                       |                     |
|--------------------|--------------------------------|------------------------------------|---|--------------|---------------------------------------|---------------------|
|                    |                                |                                    | Super Gripbelts and Unnotched Gripbands |              | Gripnotch Belts and Notched Gripbands |                     |
|                    |                                |                                    | Used Belt                               | New Belt     | Used Belt                             | New Belt            |
| A,AX               | 3.0 - 3.6                      | 1000-2500<br>2501-4000             | 3.7<br>2.8                              | 5.5<br>4.2   | 4.1<br>3.4                            | 6.1<br>5.0          |
|                    | 3.8 - 4.8                      | 1000-2500<br>2501-4000             | 4.5<br>3.8                              | 6.8<br>5.7   | 5.0<br>4.3                            | 7.4<br>6.4          |
|                    | 5.0 - 7.0                      | 1000-2500<br>2501-4000             | 5.4<br>4.7                              | 8.0<br>7.0   | 5.7<br>5.1                            | 8.4<br>7.6          |
| B,BX               | 3.4 - 4.2                      | 860-2500<br>2501-4000              | -                                       | -            | 4.9<br>4.2                            | 7.2<br>6.2          |
|                    | 4.4 - 5.6                      | 860-2500<br>2501-4000              | 5.3<br>4.5                              | 7.9<br>6.7   | 7.1<br>6.1                            | 10.5<br>9.1         |
|                    | 5.8 - 8.6                      | 860-2500<br>2501-4000              | 6.3<br>6.0                              | 9.4<br>8.9   | 8.5<br>7.3                            | 12.6<br>10.9        |
| C,CX               | 7.0 - 9.0                      | 500-1740<br>1741-3000              | 11.5<br>9.4                             | 17.0<br>13.8 | 14.7<br>11.9                          | 21.8<br>17.5        |
|                    | 9.5 - 16.0                     | 500-1740<br>1741-3000              | 14.1<br>12.5                            | 21.0<br>18.5 | 15.9<br>14.6                          | 23.5<br>21.6        |
| D                  | 12.0 - 16.0                    | 200-850<br>851-1500                | 24.9<br>21.2                            | 37.0<br>31.3 | -                                     | -                   |
|                    | 18.0 - 20.0                    | 200-850<br>851-1500                | 30.4<br>25.6                            | 45.2<br>38.0 | -                                     | -                   |
| 3V,3VX             | 2.2 - 2.4                      | 1000-2500<br>2501-4000             | -                                       | -            | 3.3<br>2.9                            | 4.9<br>4.3          |
|                    | 2.65 - 3.65                    | 1000-2500<br>2501-4000             | 3.6<br>3.0                              | 5.1<br>4.4   | 4.2<br>3.8                            | 6.2<br>5.6          |
|                    | 4.12 - 6.90                    | 1000-2500<br>2501-4000             | 4.9<br>4.4                              | 7.3<br>6.6   | 5.3<br>4.9                            | 7.9<br>7.3          |
| 5V,5VX             | 4.4 - 6.7                      | 500-1740<br>1750-3000<br>3001-4000 | -                                       | -            | 10.2<br>8.8<br>5.6                    | 15.2<br>13.2<br>8.5 |
|                    | 7.1 - 10.9                     | 500-1740<br>1741-3000              | 12.7<br>11.2                            | 18.9<br>16.7 | 14.8<br>13.7                          | 22.1<br>20.1        |
|                    | 11.8 - 16.0                    | 500-1740<br>1741-3000              | 15.5<br>14.6                            | 23.4<br>21.8 | 17.1<br>16.8                          | 25.5<br>25.0        |
| 8V                 | 12.5 - 17.0                    | 200-850<br>851-1500                | 33.0<br>26.8                            | 49.3<br>39.9 | -                                     | -                   |
|                    | 18.0 - 22.4                    | 200-850<br>851-1500                | 39.6<br>35.3                            | 59.2<br>52.7 | -                                     | -                   |

© Emerson Power Transmission Manufacturing, L.P. 1998, 1999. All Rights Reserved.

| Condition  | Possible cause   | Solution  |
|--|--|---|
| Temperature fluctuations/rapid cycling from hot to cold. | Undersized connectors/lines.   | Increase size of connectors/ water lines.   |
|  | Long connecting lines between unit and mold.   | Move the unit closer to the mold and shorten connecting lines.  |
|  | Serpentine flow through mold.  | Connect lines for parallel flow instead of series flow.   |
|  | Blocked line in mold.  | Check mold for metal chips or deposits. Clean mold.   |
|  | Quick disconnect fitting with check valve.   | Remove and replace fitting or valve.  |
|  | Carbon build-up in unit piping or fittings.  | Clean or replace affected piping. Replace fluid.  |
|  | Faulty Sterlco TCU.  | Check unit by opening the manual bypass to determine if the TCU controls the set point temperature.   |
|  | Reversed probes.   | Switch Return and Delivery probes.  |
| Unit does not heat properly/can not achieve set point.   | Loss of fluid in process.  | Check all lines/connections/ fittings.  |
|  | Vent valve open.   | Allow vent timer to run out; <b>or</b> , check valve operation when unit is cold by opening the fill port.  |
|  | Faulty/dirty solenoid valve; usually detected when there is a steady stream or trickle of water out of the drain line. | Switch to Manual Cool mode several times to flush valve. If the leak continues, disconnect the power to the unit, turn off the water supply, and clean or replace the solenoid. |
|  | Degraded fluid.  | Drain and replace fluid.  |
| Unit does not heat.                                      | Defective heater contactor.  | Visual inspection of coil and contacts. Repair/replace defective contactors.  |
|  | Defective immersion heater.  | Check resistance on all three (3) legs of heater with an ohmmeter. If not all equal, contact factory for replacement heater.  |
|  | Heater burnout.  | Check heater tank for scorched/ discolored paint. Check resistance on all three (3) legs of heater with an ohmmeter. Replace heater as needed.                                  |

| Condition                           | Possible cause   | Solution   |
|-------------------------------------|--|--|
| Unit does not heat.<br>(cont'd.)    | Controller heater output open.                                   | Check the heater output with an ohmmeter to ground. It should read in the mega-ohm range. Infinite or zero readings indicate a defective output. |
|                                     | Clogged Y strainer.  | Clean Y strainer.  |
| Unit overheats/unable to cool.      | Water supply to unit is turned <b>OFF</b> .                      | Open water supply.   |
|                                     | Water drain is plugged or excessive back pressure in drain line. | Clear drain line or eliminate back pressure condition.   |
|                                     | Heat exchanger tubes plugged by lime deposits.                   | Remove tube bundles; clean/replace as required.  |
|                                     | Faulty solenoid valve.   | Test solenoid valve by switching to Manual Cool mode and listen for valve operation. Replace if faulty.  |
| Rapid drop in pressure/no pressure. | Leaks in connecting lines.                                       | Inspect/replace faulty line or connection.   |
|                                     | Air in circulating lines.  | Perform venting sequence in Chapter 3.   |
|                                     | Low fluid.   | Check fluid level in sight glass. Add fluid if required.   |
|                                     | Defective Ful-Flo valve.   | See Chapter 3.   |
|                                     | Water in fluid.  | Drain water from low point in piping (see Chapter 3), or boil water off.   |
|                                     | Vent solenoid open.  | Allow vent timer to run out; <b>or</b> , check valve operation when unit is cold by opening the fill port.                                       |
|                                     | Pump running in reverse.   | Check motor; rewire if necessary. See electrical diagrams.   |
|                                     | Pump repair/adjustment needed.                                   | Adjust head spacing or replace worn pump components.   |
|                                     | V belt broken/worn.  | Replace as required.   |
| Noisy pump.                         | Water in fluid.  | Drain water from low point in piping (see Chapter 3), or boil water off.   |
|                                     | Severely degraded fluid.   | Drain and flush system. Replace fluid.   |









## Technical Assistance

### Parts Department

Call toll-free 7am–5pm CST or call [800] 423-3183, [262] 641-8610, or fax to [262] 641-8653

The ACS Customer Service Group will provide your company with genuine OEM quality parts manufactured to engineering design specifications, which will maximize your equipment's performance and efficiency. To assist in expediting your phone or fax order, please have the model and serial number of your unit when you contact us. A customer replacement parts list is included in this manual for your convenience. ACS welcomes inquiries on all your parts needs and is dedicated to providing excellent customer service.

### Service Department

Call toll-free 8am–5pm CST [800] 423-3183 or call [262] 641-8610  
Emergencies after 5pm CST, call [847] 439-5655

We have a qualified service department ready to help. Service contracts are available for most products. Service contracts are available for most of our products. [www.acscustomerservice.com](http://www.acscustomerservice.com)

### Sales Department

Call [262] 641-8610 Monday–Friday, 8am–5pm CST, fax [262] 641-8653

Our products are sold by a world-wide network of independent sales representatives. Contact our Sales Department for the name of the sales representative nearest you.

### Contract Department

Call [262] 641-8610 Monday–Friday, 8am–5pm CST

Let us install your system. The Contract Department offers any or all of these services: project planning; system packages including drawings; equipment, labor, and construction materials; and union or non-union installations.

Sterling, Inc.  
2900 S. 160<sup>th</sup> Street  
New Berlin, WI 53151  
[www.sterlco.com](http://www.sterlco.com)

## Free Manuals Download Website

<http://myh66.com>

<http://usermanuals.us>

<http://www.somanuals.com>

<http://www.4manuals.cc>

<http://www.manual-lib.com>

<http://www.404manual.com>

<http://www.luxmanual.com>

<http://aubethermostatmanual.com>

Golf course search by state

<http://golfingnear.com>

Email search by domain

<http://emailbydomain.com>

Auto manuals search

<http://auto.somanuals.com>

TV manuals search

<http://tv.somanuals.com>