

STERICO TEMPERATURE CONTROL UNIT
SERVICE AND INSTRUCTION MANUAL
MODELS: 6312-A, 6322-A, 6332-A

Engineered and manufactured by INDUSTRIAL CONTROL DIVISION, STERLING, INC.
5200 West Clinton Avenue, Milwaukee, WI 53223
Manufacturers of Temperature Control Equipment since 1916

Please note that our address and phone information has changed. Please reference this page for updated contact information.



These manuals are obsolete and are provided only for their technical information, data and capacities. Portions of these manuals detailing procedures or precautions in the operation, inspection, maintenance and repair of the products may be inadequate, inaccurate, and/or incomplete and shouldn't be relied upon. Please contact the ACS Group for more current information about these manuals and their warnings and precautions.

Parts and Service Department

The ACS Customer Service Group will provide your company with genuine OEM quality parts manufactured to engineering design specifications, which will maximize your equipment's performance and efficiency. To assist in expediting your phone or fax order, please have the model and serial number of your unit when you contact us. A customer replacement parts list is included in this manual for your convenience. ACS welcomes inquiries on all your parts needs and is dedicated to providing excellent customer service.

For immediate assistance, please contact:

- North, Central and South America, 8am – 5pm CST +1 (800) 483-3919 for drying, conveying, heating and cooling and automation. For size reduction: +1 (800) 229-2919.
North America, emergencies after 5pm CST (847) 439-5855
North America email: acsuscanadacustserv@corpemail.com
- Mexico, Central & South America
Email: acslatinamericacustserv@corpemail.com
- Europe, Middle East & Africa +48 22 390 9720
Email: acseuropecustserv@corpemail.com
- India +91 21 35329112
Email: acsindiacustserv@corpemail.com
- Asia/Australia +86 512 8717 1919
Email: acsasiacustserv@corpemail.com

Sales and Contracting Department

Our products are sold by a worldwide network of independent sales representatives. Contact our Sales Department for the name of the sales representative nearest you.

Let us install your system. The Contract Department offers any or all of these services: project planning; system packages including drawings; equipment, labor, and construction materials; and union or non-union installations.

For assistance with your sales or system contracting needs please Call:

North, Central and South America +1 (262) 641-8600 or +1 (847) 273-7700 Monday–Friday, 8am–5pm CST

Europe/Middle East/Africa +48 22 390 9720

India +91 21 35329112

Asia/Australia +86 512 8717 1919

Facilities:

ACS offers facilities around the world to service you no matter where you are located. For more information, please visit us at www.acscorporate.com

United States:

ACS Schaumburg – Corporate Offices

1100 E. Woodfield Road
Suite 588
Schaumburg, IL 60173
Phone: + 1 847 273 7700
Fax: + 1 847 273 7804

ACS New Berlin – Manufacturing Facility

2900 S. 160th Street
New Berlin, WI 53151
Phone : +1 262 641 8600
Fax: + 1 262 641 8653

Asia/Australia:

ACS Suzhou

109 Xingpu Road SIP
Suzhou, China 215126
Phone: + 86 8717 1919
Fax: +86 512 8717 1916

Europe/Middle East/Africa:

ACS Warsaw

Ul. Działkowa 115
02-234 Warszawa
Phone: + 48 22 390 9720
Fax: +48 22 390 9724

India

ACS India

Gat No. 191/1, Sandbhor Complex
Mhalunge, Chakan, Tal Khed,
Dist. Pune 410501, India
Phone: +91 21 35329112
Fax: + 91 20 40147576



S-series

sterl-tronic water circulating temperature system

closed-circuit type

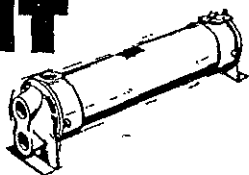

- Constantly recirculates the same water to the process. Cools through shell-and-tube heat-exchanger. This substantially reduces lime and scale build-up, where water quality is low. Built for precise control and maximum convenience in operation and upkeep.
- Circulates water at precisely controlled temperatures—up to 250°F. Responds to the demands of the process and heats or cools as required—automatically and precisely with anticipated and proportioned control.
- Solid-state electronic thermostat—designed by Sterling specifically for this application and built by Sterling to rigid standards of quality. An on-purpose design, with positive control over quality and performance.
- Available with standard circulating capacity, and also available as high-capacity "Muscle Unit" for accelerated heat transfer.

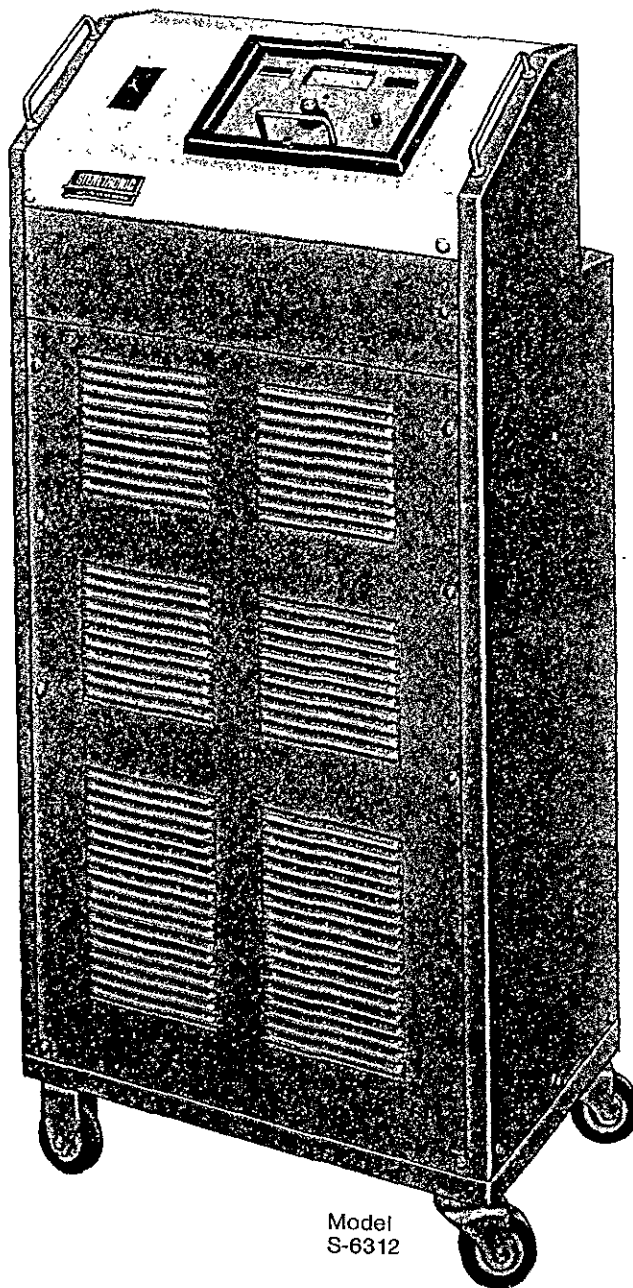

Model
S-6312

Model	Zones	Width	Depth	Height	Shipping Wt.
S-6312	1	20 $\frac{3}{4}$ "	15"	47"	240 lbs.
S-6322	2	41 $\frac{1}{2}$ "	15"	48"	475 lbs.
S-6332	3	62 $\frac{1}{4}$ "	15"	48"	795 lbs.

**Leadership
and research
provide you
with...**

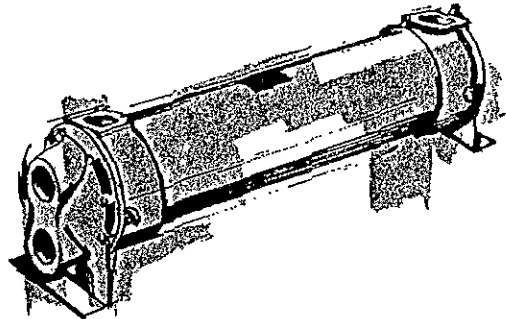

Shell and Tube Heat Exchanger where raw water cools the circulated water without mixing. Standard size is approximately 4 sq. ft.—much larger sizes available.

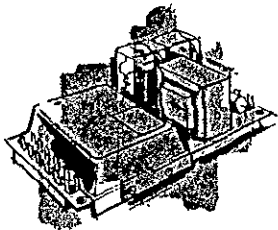

Solid-State Thermostat for precise control. This rugged, modern control will automatically respond to the needs of the process—can give either *full output* or *proportioned output* as required by the user's process. Has an adjustable dead-band and plug-in relays.

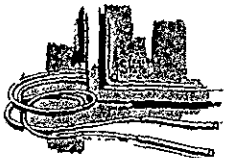

Dual Sensors for each thermostat provide the means for anticipation and proportioned control.



Temperature Indication via meter-readout which is part of the thermostat. Fast acting and easily read.



Pilot Lights show when the unit heats and when it cools—operation can be checked at a glance.

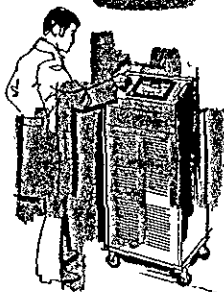

Controls Ideally Located for easy and convenient operation, and they are protected. No stooping or bending needed to check or operate this unit.

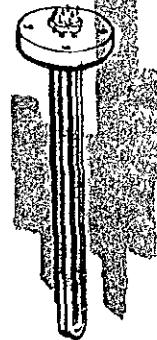

Heater is flange mounted and vertically suspended, without any bending stress. A 9000 watt heater is standard, although 4500 watt or 12,000 watt can be supplied. Water is caused to flow along the surface of the element to absorb heat at fastest rate, and to give long heater life and minimum fouling.



Push Button Air Purge enables the user to purge the unit, hoses and his process from entrapped air before start-up. Reliable and thorough.

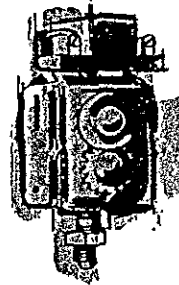

Pressure Switch protects against damage from operation without water. It has adjustable setting.

OPTIONS

SEPARATE WATER SUPPLY Connections for process water and for raw water. Permits circulation of high quality process water and cooling with raw water.

6500 SERIES Converts from closed circuit to direct injection type with flick of switch, thereby boosting total cooling ability at low temperatures.

MUSCLE UNITS designed to give high volume "turbulent water flow" through the user's process. This turbulent flow can greatly improve heat transfer, improve product quality, reduce tendencies for sweating and increase efficiency of operation. Muscle units can be fitted with larger total cooling capacity. Sterlco engineering advances pay off handsomely for you at very modest extra cost. These "years ahead" standards are proved and available now. The "Muscle Units" use the same cabinets and instruments, but employ much greater circulating capacity and cooling ability.

Sterling inc.



5200 WEST GLINTON AVENUE, MILWAUKEE, WISCONSIN 53228
TELEPHONE 414 354-0970 TELEX 2-6805

LITHO IN U.S.A. 11-79

MODELS: 6312-A, 6322-A, 6332-A

INDEX PAGE

	<u>PAGE</u>
INTRODUCTION	1-2
DESCRIPTION	2
CIRCULATION	2-5
PERFORMANCE	6
INSTALLATION	7
FLOW DIAGRAM (S6312-A) (Dwg. B682-03906)	8
FLOW DIAGRAM (S6322-A) (Dwg. C682-03908)	8
FLOW DIAGRAM (S6332-A) (Dwg. C682-03909)	8
ELEMENTARY DIAGRAM (S6312-A) (B682-00833)	9
ELEMENTARY DIAGRAM (S6322-A) (C682-00834)	9
ELEMENTARY DIAGRAM (S6332-A) (C682-00835)	9
OPERATION	10-11
TROUBLE SHOOTING (UNIT)	TS 1-4
TROUBLE SHOOTING (CONTROLLER)	STS-1-4
CALIBRATIONS (Dwg. B681-00031 & Dwg. B681-00013)	
PUMP BULLETIN	MP/MS-1
PUMP	I-4100-E1
1/2" HOSE ASSEMBLY	14289
3/4" HOSE ASSEMBLY	14339
SWITCH BULLETIN	600
HEATER ELEMENT	600
SOLENOID VALVE	8262-62A
SPARE PARTS LIST	133
WARRANTY	

MODELS: 6312, 6322, 6332

INTRODUCTION

We are pleased to provide a Water Circulating Temperature Control Unit for your application. It is built by skilled craftsmen with the most modern and precision machines available today. The simplicity of design and compactness engineered into the unit resulted in less maintenance and less floor space.

The Sterl-Tronic Temperature Control Unit; designed and tested over a period of many years, represents one of the most significant advances ever in the field of self-contained, closed systems - portable units for heating water and circulating it at controlled temperatures - through molds, rolls or jackets of processing equipment.

The Models 6312, 6322, 6332 are complete single, dual and triple zone heating, cooling, and circulating control units, with delivery and return lines, plus one water supply line and a drain line for cooling.

The Sterl-Tronic temperature control unit is designed to circulate water through your process and to precisely, automatically, and reliably maintain this water at the selected temperature. The operating range of the Sterl-Tronic unit is from supply water temperature up to 250°F. maximum. The unit is well suited for use with a city water supply, water from portable or central chillers, towers or with well water.

Many new improved designed features have been incorporated into the Sterl-Tronic; among them the solid-state electronic thermostat, automatic mechanical proportioning of heating and cooling, dual electronic sensing probes, push button air vent.

The relatively small total amount of water, rapidly circulated by the Sterl-Tronic, provides assurances of a close and uniform temperature relationship between the delivery and return lines of the unit. This assures uniform and stable temperature control as well as a very even temperature throughout the work area. Also, the high rate of circulation, combined with the large immersion heater and high cooling rate, gives the unit exceptionally fast response in bringing the process up to temperature and in making changes of settings when necessary.

These standard units may have many variations of optional features added to them, relative to the customers application of specific desires.

The illustrations used are to help you identify certain parts by name and to understand our explanations - which will assist you later on in the Trouble Shooting sections.

CIRCULATION (cont.)

Cooling

Cooling is accomplished by the automatic release of cooling water through the shell of the specially designed shell and tube heat exchanger in each zone. The process fluid, i.e. water, glycol or other similar fluid is circulated through the tubes of the heat exchanger.

Naturally the plant water supply temperature will govern the minimum operating temperature of the unit. A keep filled feature for the circulating system is standard with the Sterl-Tronic units. If desired as an option, a separate supply for the closed circuit can be furnished if a fluid other than plant water is used.

If this separate supply is desired, a means must be provided to maintain pressure in that system to prevent boiling of the fluid at elevated temperatures.

Connection Lines

On the Model 6312-A the water supply and drain line are 1/2" N.P.T. The Return and delivery lines are 3/4" N.P.T. On the Models 6322-A and 6332-A all lines are 3/4" N.P.T.

Hoses are adequate to withstand the maximum temperatures and pressures at which the unit is to be operated.

Hoses, fittings and channel connections in the mold or other equipment being controlled should be at least 3/4" in order not to restrict the flow of fluid through the circuits; if the flow is restricted by too small of connecting hoses or hoses with excess bends, loops, etc. the pressure will increase and the flow through the process will be greatly reduced.

If your mold, i.e. has already been made with serpentine channeling, we would like to suggest modification as shown in Dwg. A682-03844 and using a manifold, preferably of 3/4" N.P.T. pipe.

In order to eliminate any back pressure - it would be advisable to drill holes at points "A" and tap for 3/4" pipe.

Several parallel runs are far more practical than one long serpentine run and in many cases, can make a difference between precise control and erratic operation.

WATER SUPPLY

It is very important that the water supply to the unit meet certain requirements. We recommend a full sized hose, equal to the pipe size of our water supply connection and without restricting fittings. Usable supply pressure should be in excess of 20 PSI (1.4 KG/CM²) and preferably

WATER SUPPLY (cont.)

over 25 PSI (1.75 KG/CM²) at the unit. If the unit is expected to operate at temperatures over 200 F. (93°C). This minimum pressure is necessary to keep the process water from flashing to steam at the pump inlet, where water pressure is the lowest in the system. The pressure switch inside the unit will keep the unit from running until the unit has been subjected to a minimum water supply pressure.

The water supply line should be open to the unit whenever the unit is running. While a certain minimum supply pressure is necessary as stated above, supply pressures over 75 PSI (5.27 KG/CM²) while serving no useful purpose may indeed cause damage to the unit and shorten its life. If your water pressure is excessively high it is recommended that a pressure regulator be installed in the supply line with a relief downstream from the regulator and set slightly higher than the regulator. Hard or corrosive water can be damaging to the unit and your equipment, especially since the temperatures at which the system operated tend to accelerate deposits or corrosion. Also, bad water can build layers of scale or lime on the surfaces of the unit, slowing down water flow and causing control problems and eventual damage to the equipment. Since the corrective maintenance and downtime often caused by bad water are costly, it is well worthwhile to treat that water. In general, we have found that people with good water seldom buy parts. Industrial water treatment to neutralize these conditions is relatively inexpensive and in many cases is truly a wise investment.

HEATER

Heater is a three phase immersion heater, 9 KW is standard capacity of low watt density construction to minimize fouling and to promote longer heater life. A 4-1/2 KW and a 12 KW low watt density heater may be provided as an alternate.

ELECTRICAL

The control circuit and pump operate on 115 volt, single phase current. A single phase transformer provides 115 volt single phase current for the control circuit and motor. A manual starting switch with an electrical overload protects the motor.

VENT PUSH BUTTON

This push button permits quick and complete purge of air from the operators panel, before the unit is started. The "VENT" push button actuates the solenoid valve which permits the flow of trapped air and water out through the drain, insuring that the unit is properly filled and primed prior to start-up.

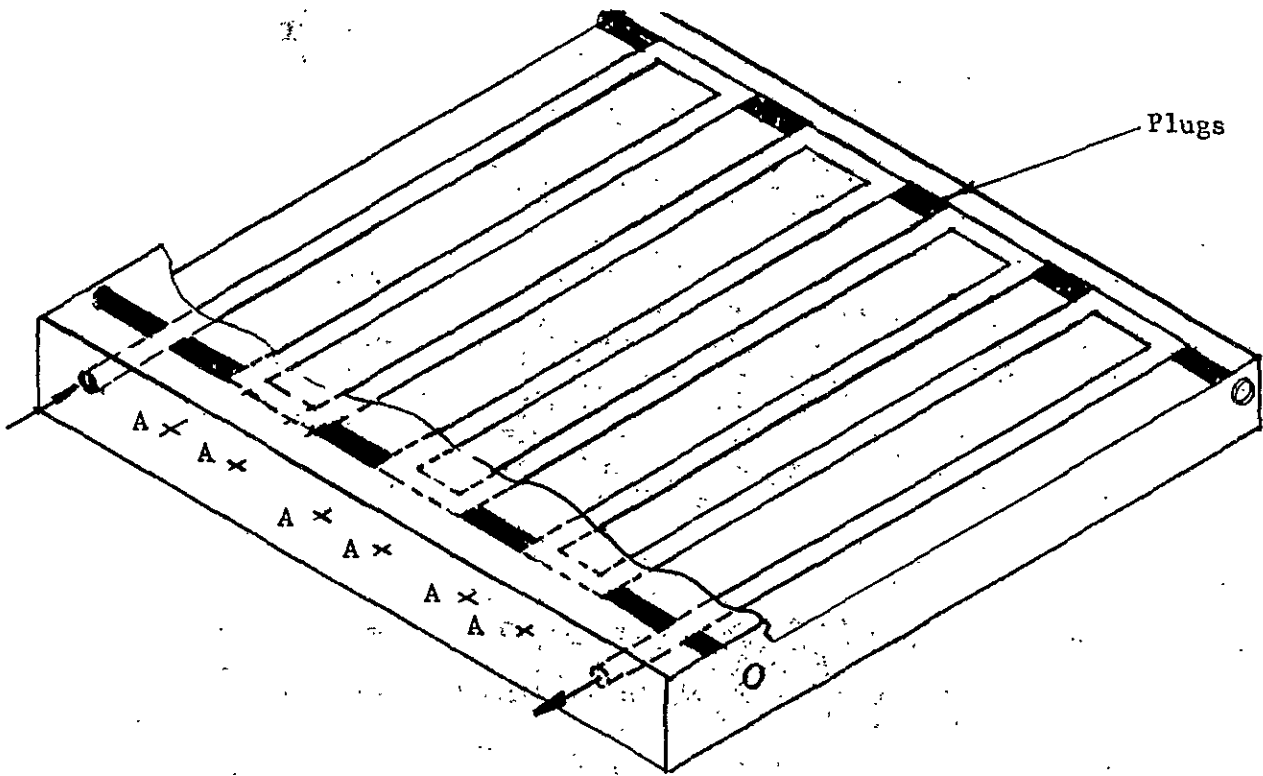

Modification of Platen
For Manifold

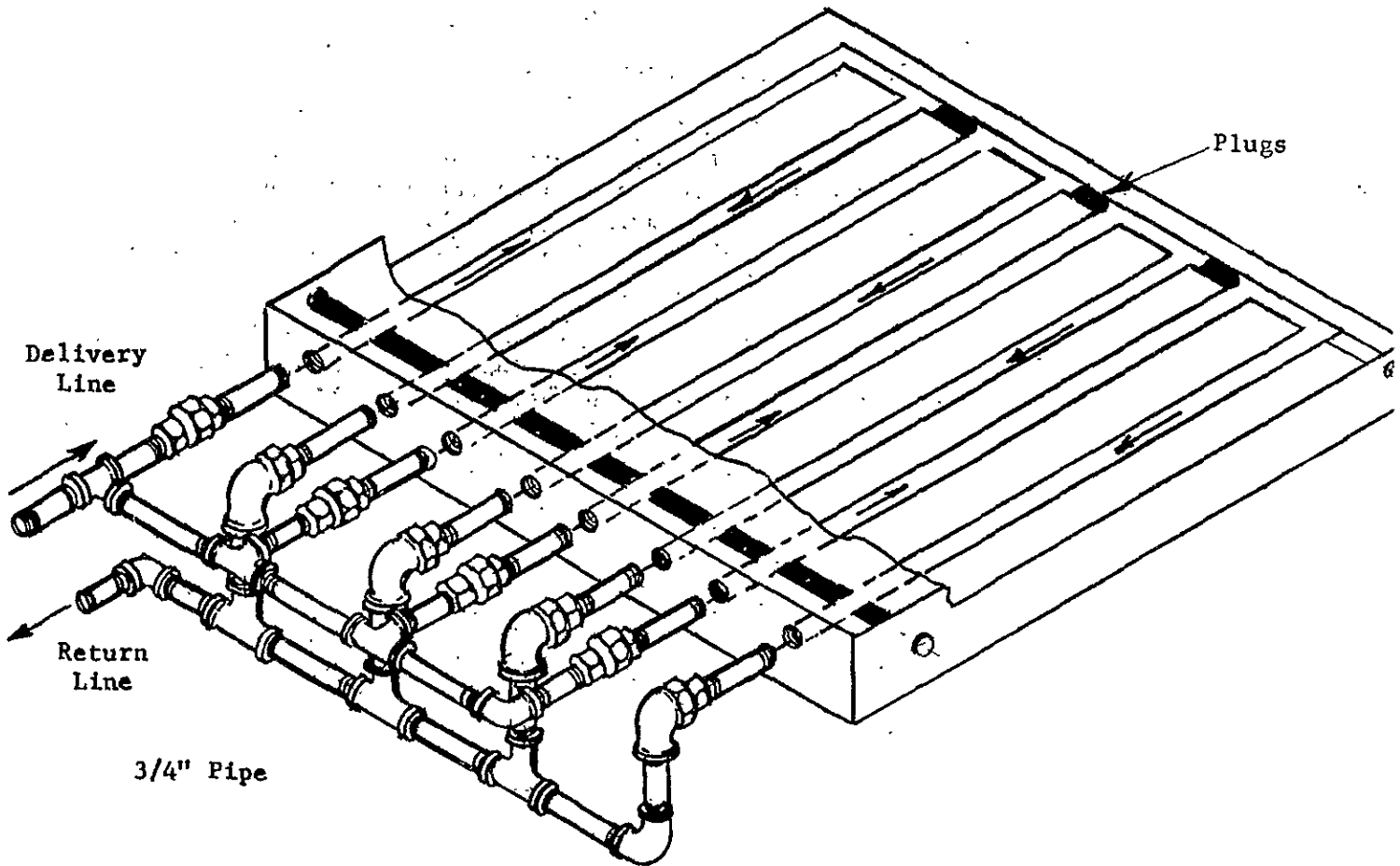

Fig. 1

MODELS: 6312, 6322, 6332

PRESSURE SWITCH

The Pressure Switch is built into each unit to insure that the unit will not start until the water supply has been turned on and the unit subjected to water supply pressure. This is intended to provide a strong measure of protection for the pump seal and the heater so that they will not be damaged through operation without water. The final measure of protection must come from the operator in venting before start-up. The pressure switch itself is set at approximately 10 PSI prior to leaving Sterling.

PERFORMANCE

The Models 6312, 6322, and 6332 are easy units to operate.

The simplicity of design and the highly engineered controller make these units almost self-operated.

The "ON-OFF" control, the "VENT" button and the "TEMPERATURE CONTROLLER" are all that is required to operate these units.

After the water supply has been connected up to the "WATER SUPPLY LINE" (the pressure must be in excess of 20 PSI and preferably over 25 PSI, but not to exceed 50 PSI).

When the "VENT" button is depressed and held for at least one minute, the solenoid valve opens electrically.

As the water comes in on the water supply line and as the check valve is closed, the water must enter the pump, down through the bottom of the tank; up through the tank and out through the "DELIVERY LINE"; through the process, back through the "RETURN LINE" and through the open solenoid valve and out the "DRAIN LINE"

At this time, watching the drain for bubbles or erratic flow will indicate whether or not the system has been properly "purged". If a steady stream flows from the drain line, it is certain that all the air is out of the system.

"ON-OFF" SWITCH

On Position

When the switch is in the "ON" position, the starter is manually energized and supplies the power to the motor and the temperature controller, which in turn regulates either "heating or cooling".

Off Position

When the switch is in the "OFF" position, the starter is de-energized, cutting the voltage to the motor and the temperature controller.

MODELS: 6312, 6322, 6332

"ON-OFF" SWITCH: (cont.)

Control Fuse

This fuse protects the complete 115 volt control circuit.

INSTALLATION

Initial Procedure

These units are supplied for three phase operation for a selected voltage. Caution must be taken to provide a correctly sized power supply to the unit. These units must be correctly grounded.

All connections must be secure and should be checked before starting.

Electrical

Knockouts are provided for entry for electrical service on each side of the cabinet.

<u>HEATER CAP. EACH CIRCUIT KW</u>	<u>TOTAL AMPS. 3/60/240</u>	<u>TOTAL AMPS. 3/60/480</u>
4-1/2 KW	10.8 AMPS.	5.4 AMPS.
9 KW	21.6 AMPS.	10.8 AMPS.
12 KW	28.8 AMPS.	14.4 AMPS.

R.P.M. Listed for 60 HZ. Application
Full Load AMPS. @ 50 HZ 2% More Than Listed

H.P.	RPM	208V.	230V.	380V.	415V.	460V.	575V.
1/2	1800	2.21	2.0	1.21	1.11	1.0	0.8

CIRCULATION

Flow Diagram (See Dwg. Page 8)

Heating

With the "ON-OFF" switch in the "ON" position and the temperature controller set to the required heat, the water is drawn into the pump - pass cooling sensor, out into the bottom of the heater tank.

As the water is circulated up through the heater tank, it is heated by the immersion heater, where it passes the heating sensor, which is recorded on the temperature controller and out to the delivery line.

MODELS: 6312, 6322, 6332

CIRCULATION: (cont.)

Heating (cont.)

After it is routed through the process supply, the heated water, which has cooled down a bit, comes back into the return line through the heat exchanger for recirculation, through the pump and cack down into the bottom of the heater tank, where it is reheated.

The by-pass line is a safety feature in the event there is a malfunction in the system, external of the unit proper. The by-pass line allows a small amount of water to recirculate internally to the unit.

Cooling

As the water returns back from the process it enters the heat exchanger from the top and flows through the inside of the cooling tubes and out the bottom of the heat exchanger into the pump and past the cooling sensor.

When the process supply needs cooling, the temperature controller energizes the 1/2" cooling solenoid valve which opens, the cooling water enters the bottom side of the heat exchanger (Shell) and circulates around the outside of the cooling tubes picking up heat from the process supply and out the top side of the heat exchanger, through the 1/2" solenoid valve and out the drain line.

When the cooling sensor has been satisfied the temperature controller turns off the 1/2" solenoid valve and cooling no longer takes place.

OPERATION

Vent the unit as described, and position the "ON-OFF" switch to the "ON" position.

Set the Set Point on the temperature controller to the desired heat.

As the unit is in the heating cycle, the Heat Indicator Light will illuminate if the heat of the water travels above the set point, the unit will automatically switch to the cooling cycle and the Cooling Indicator Light will illuminate.

SHUTDOWN

Prior to shutdown, the water supply to the unit should be shut off.

Depress the "VENT" button for a few seconds to relieve the internal pressure. Water supply and drain lines, delivery and return lines and the electrical supply may then be disconnected.

MODELS: 6312, 6322, 6332

DRAINING

If your Sterl-Tronic is to be taken out of service for a long time or it will be exposed to freezing, it should be thoroughly drained. Drain plugs are provided at the base of the heater tank and water supply and drain lines.

OPERATION OF ONE ZONE ONLY OF DUAL OR TRIPLE ZONE UNIT

When one zone of a dual or triple zone unit is to be operated while the other remains idle, it is necessary to run a by-pass line from the delivery to the return line of the idle zone.

Free Manuals Download Website

<http://myh66.com>

<http://usermanuals.us>

<http://www.somanuals.com>

<http://www.4manuals.cc>

<http://www.manual-lib.com>

<http://www.404manual.com>

<http://www.luxmanual.com>

<http://aubethermostatmanual.com>

Golf course search by state

<http://golfingnear.com>

Email search by domain

<http://emailbydomain.com>

Auto manuals search

<http://auto.somanuals.com>

TV manuals search

<http://tv.somanuals.com>