

STERLING

POWER PRODUCTS

3 in 1 COMBINED PURE SINE WAVE INVERTER UPS / BATTERY CHARGER (SOLAR & SHORE) USER MANUAL

Sterling Power Products
England Tel. 01905 453999
Fax 01905 458836

www.sterling-power.com

help@sterling-power.com



Content

A. General Information -----	1
B. Warranty -----	2
C. Introduction -----	4
D. Installation -----	8
E. Operation -----	11
F. Disabling Functions -----	17
G. Charger Information -----	19
H. n/a	
I. Auxiliary Contacts -----	21
J. The Remote control unit -----	21
K. n/a	
L. Programming Aux Contacts (AUX1, AUX2) -----	22
M. Maintenance -----	23
N. Specifications -----	24

General :

- “3 in 1” It is a powerful pure sine wave inverter, a sophisticated battery charger that features adaptive charge technology and a high-speed AC transfer switch in a single compact enclosure.
- Besides all this functions ,however, the “3 in 1” has several advanced features that provides a range of new applications as outlined bellow :
In the event of a grid failure ,or shore or generator power being disconnected, the inverter within the “3 in 1” is automatically In less than 20 milliseconds activated and takes over supply to the connected loads.
- Allowed them to continue to operate without disruption. The “3 in 1” is very powerful battery charger. It will therefore draw a lot of current from the generator or shore side supply.

● **INVERTER :**

- Pure Sine Wave AC output.
- Very low total harmonic distortion (< 2 %)
- High surge capacity and soft-start design for heavy inductive loads such as air conditioning
- Load detection system for “power saving” mode
- Extremely high efficiency.

● **Battery Charger :**

- The “3 in 1” series is built around a bi-directional converter , that operates as an inverter or as a battery charger high capacity three-stage Battery charger Equalization mode conditions Battery for longer life
- Multistage charger-power factor corrected for superior
- Charging temperature sensitive charging for optional
- Care of all batteries (temperature sensor optional) Built in solar charge regulator.

● **Bypass Function :**

- Automatic 60 A (3000W) / 30 A (1500W) transfer relay turns inverter and charger on / off.
- Fast (UPS) mode or delay mode of the Bypass switch.
Power sharing prevent tripping of shore power breaker.

● **Basic Remote Control :**

- Power output on / off
- Function mode select
- Programming Battery charging voltage
- Error message display
- Programming auxiliary relay (x2)
- Programming input current limit for power share

A. General Information

Operating instructions

This manual is a part of the delivery package of every inverter-charger. It serves as Guidelines for safe and efficient operation of the unit. The instructions are only valid for use with the following models and accessories.

- DAI-1500C-12xx / DAI-3000C-12xx
- DAI-1500C-24xx / DAI-1500C-24xx
- Temperature BTS-A-15 (m)
- Remote controller RCC-A-03 (3m) / RCC-A-15 (15m)

Any personnel who install the unit and / or works with it must be fully familiar with the contents of this manual and must follow exactly all the warnings and safety instructions. A qualified and trained personnel must carry out installation of , or any work on the unit . Installation and application must comply with the respective local installations codes and safety regulations.

B. Warranty

During production and assembling, all Sterling Inverter / Chargers go through many testing procedures. Every Sterling has its own serial number, which helps to refer back to its original data in the event of controls or repairs. That is why you should never remove the identification plate showing the serial number and must ensure you return your warranty card as soon as possible.

The warranty period for your Sterling is 2 years.

Sterling Warranty Terms and Conditions

Sterling warrants this product against defects in material or workmanship, to the original purchaser only for an initial period of 60 days from date of purchase, when in normal use and service. The warranty period will be extended to a total of one (1) year if a completed warranty card is received within 60 days of purchase. No warranty will be provided on units which have not been paid for in full.

Some models may have the option of purchasing an extended warranty period, see elsewhere in this manual for details. This manufacturers warranty is in addition to your consumer rights under local trade practices act.

This warranty does not extend to products which have been opened, altered or repaired by persons other than authorized by Sterling or to products which become defective due to acts of God, fire, sabotage, vandalism, contaminated fluids, negligence or failure to operate, house and maintain the product in accordance with instructions provided in this manual. **It is extremely important that all installation instructions contained within this manual are strictly adhered to , failure to do so will void your warranty.** Except for the foregoing expressed warranty Sterling makes no warranty, expressed or implied, including but not limited to, the warranty of merchantability or fitness for a particular purpose.

Sterling will repair or replace the defective product in accordance with its best judgment, For service under warranty, , if the product is found to be defective, within the terms of the warranty. Repair or replacement of any unit does not extend the original warranty terms in any way.

This warranty does not cover repairs made necessary due to the product coming in contact with dirt, abrasives, moisture, rust, corrosion, varnish or other similar, or failure due to poor quality or poor condition batteries.

Sterling reserve the right with some models to supply an accredited installer with replacement parts, this may allow the unit to become operable much quicker. In this case Sterling are not responsible for any costs of the installer's time or traveling expenses. Replacement parts are sent at Sterling's discretion.

Sterling will in no way be held responsible for any losses incurred due to the malfunctioning or failure of a product.

Suitably qualified personnel must carry out wiring, failure to do so will void warranty.

If you have any questions about this warranty please do not hesitate to contact us.

Caution: Even when a unit has been completely disconnected, there can still be deadly voltages present at the OUTPUT. To remove these voltages you must switch the unit ON with the ON/OFF switch. After one minute the electronics are discharged and any work can now be safely carried out.

Caution: In normal use lead-acid and lead-gel batteries give out explosive gases. Never smoke or allow a spark or flame in the vicinity of batteries. The batteries must always be stored or placed in a well ventilated area, they should be placed in such a way that there is no danger of short circuiting through carelessness. Never charge frozen batteries.

This unit is not to be used or sold for life support equipment or applications.

B.1 Special Precautions

While working on batteries there should always be a second person close to you or within your voice range, in case help is needed.

Plenty of fresh water and soap must be ready at hand so that in case of acid coming in contact with skin, eyes and clothes, the areas in question can be thoroughly washed.

If acid enters the eyes, you must thoroughly wash the eyes with cold running water for at least 15 minutes. It is recommended that you immediately consult a medical doctor.

Baking powder neutralizes battery acid electrolyte. Always keep some at hand. Special care must be taken when working with metal tools near or on the batteries. With tools such as screwdrivers, spanners etc. short-circuits can result. Sparks produced by the short-circuit can cause an explosion.

When working on batteries all personal metal items such as rings, necklaces and bracelets must be removed. Batteries are so powerful that short-circuit with these items can melt them and thus cause severe burns. Always follow the battery manufacturers instructions.

Under certain conditions this unit or a connected generator can start automatically. While working on an electrical installation you must ensure that these appliances are disconnected before commencing any work.

C. Introduction

C.1 Basic schematic

This unit is a sine wave inverter with integrated battery charger and AC Bypass switch with many additional functions.

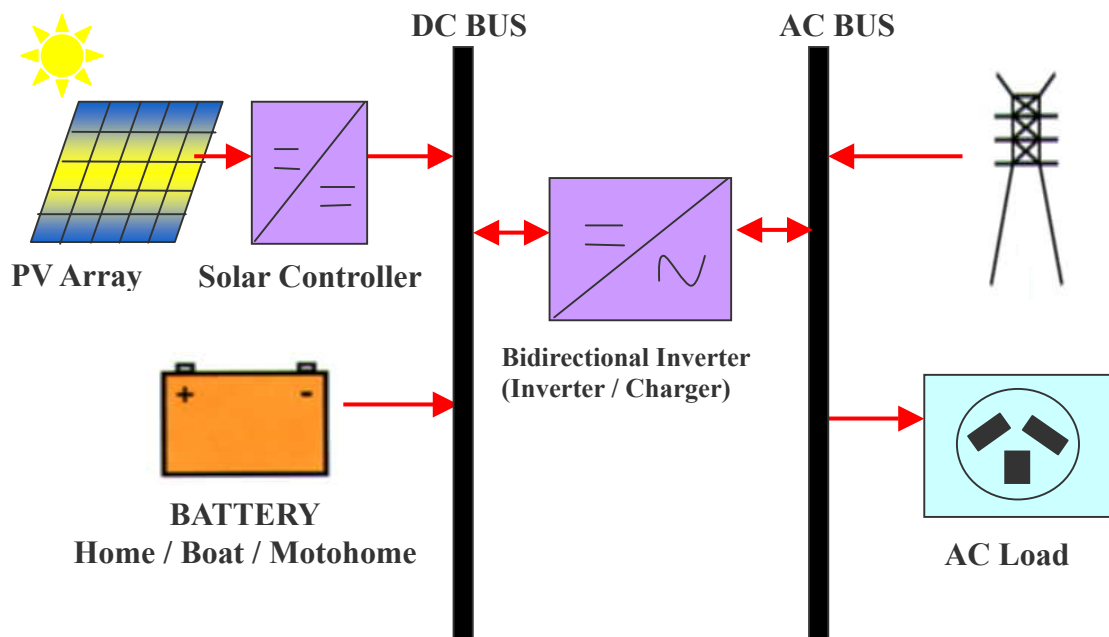

C.1.1 The Inverter

The sinewave-inverter section of your Combi generates a sinewave AC voltage with an exceptionally precise voltage and stabilized frequency, In order to start large electric motors, the user has the possibility to employ a short-start-power which is 3-times the nominal power of the Combi

The inverter is protected against overload and short-circuit. A power-stage with the latest MOS-FET power transistors, a toroidal transformer, and a fast regulating system make-up a robust and reliable inverter with very high efficiency. A load detection system serves to provide the smallest energy consumption and ensures a long life for the battery.

C.1.2 The Bypass switch

This unit can be connected to an AC input source. For example a stand-by motor generator or the AC grid, such as shore power or a caravan park. With the transfer system, on one side you have AC voltage which is used to run the load, on the other side the batteries are being charged. The distribution of energy between the AC loads and battery charger is automatic.

C.1.3 The Battery charger

The built-in battery charger is capable of charging the batteries quickly and completely. A microprocessor controlled, 3 to 4 Step charging process ensures the optimum charging of the batteries. The desired charging current can be set. The battery charger can be used for lead-acid or gel batteries. Thanks to the floating charge ability of this unit, the batteries can remain continuously connected.

C.1.4 The solar charge regulator (optional)

With the built-in solar regulator, the unit is a complete solar-power-center. In a solar installation this regulator ensures that the batteries are charged correctly. With the unit, batteries can be charged with a generator and with the solar modules at the same time. The charging of batteries with both energy sources is carried out fully automatically.

C.1.5 Remote control

As an option, a remote control can be connected to this unit. The remote control is supplied with a 3m long cable. This cable can be up to 15m long. (RS-485 interface) On the remote control output current and charging current are also shown.

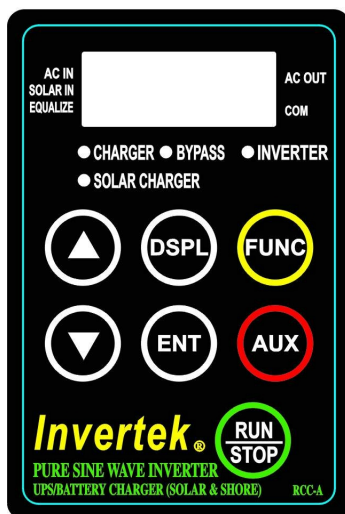

C.2 Battery connections

Lead-acid batteries are normally available in blocks of 2V, 6V or 12V. In most cases, to generate the necessary operating voltage and the capacity of the batteries for the unit many batteries have to be connected together in parallel and or in series. Following three examples are shown:

C.2.1 Parallel Connection:

12V

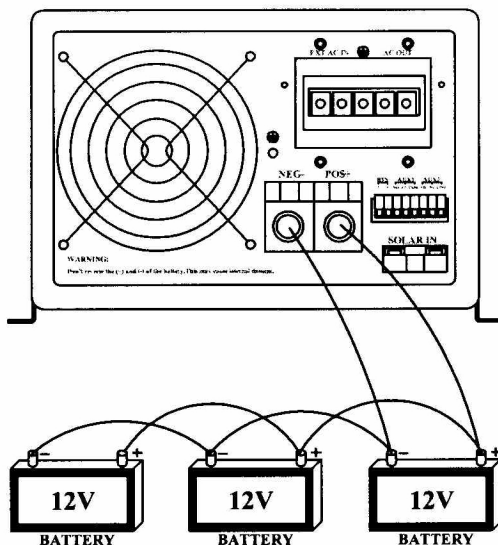

C.2.2 Series Connection:

12V

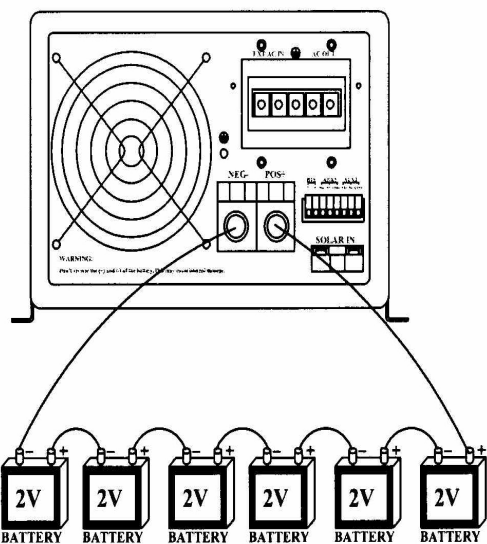

24V

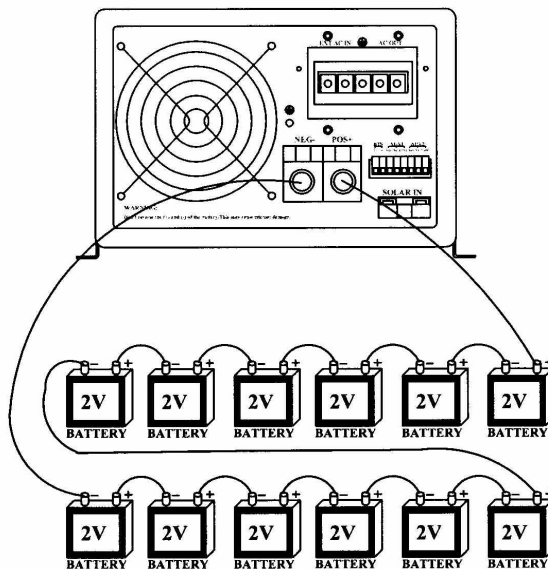

C.2.3 Parallel-Series Connection:

24V

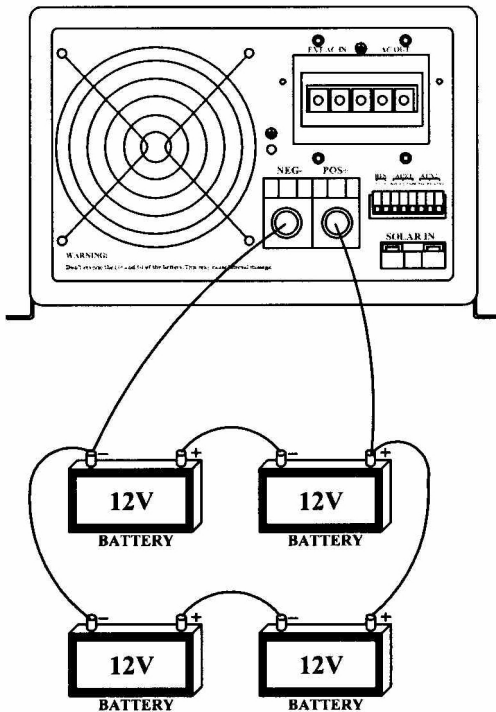

D. Installation

D.1 Location

The location of the Combi must be chosen by the following criteria:

Protection from unauthorized handling.

Dry dust free room, no condensation, no rodents.

Never install directly over the battery and never in a cabinet together with the batteries.

Keep ventilation holes free. The ventilation of the Combi is designed in such a way that it will work most efficiently when mounted vertically.

In mobile installation it is important to keep vibrations to a minimum.

D.2 Rear Panel

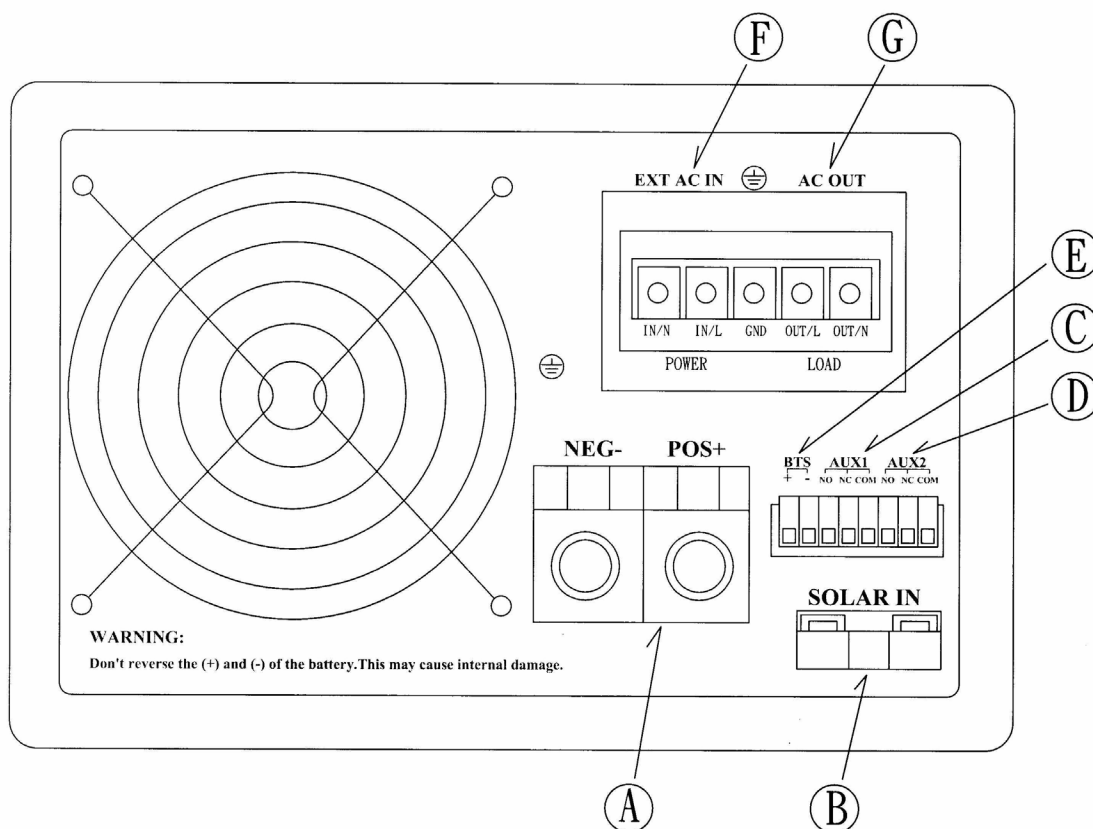

Connections

A Battery +/-

B SOLAR +/-

C AUX1 contact

D AUX2 contact

E BTS (Battery temp. sensor)

F EXT AC IN

G AC OUT

Battery cables.

Connections for Solar modules.

Connecting terminal for Auxiliary contact 1.

Connecting terminal for Auxiliary contact 2.

Connecting terminal for Temperature sensor.

Connecting terminal for AC input.

Connecting terminal for AC output.

D.3 Cabling / wiring

When making connections to the unit you must ensure that all connections are carried out in a clean and correct manner and under no circumstances that a cable is connected to a wrong terminal.

Connecting the unit must be carried out in the following order.

D.3.1 Connection to battery

Prepare the batteries for connection. Prepare battery cables, if necessary press on cable tabs/shoes. Connect the red cable to the Battery positive fuse/circuit breaker and the black cable to battery Minus (-) Take care when connecting the second cable to the battery, as a spark is produced, this is caused for a short time due to high current flowing in the unit to charge the capacitors. This is another reason to install a battery fuse/circuit breaker. For this reason follow strictly the safety measures described in this manual.

DO NOT INSERT THE BATTERY FUSE AT THIS STAGE.

D.3.2 Connection to the AC OUTPUT.

The AC output must be connected to the screw terminal AC OUTPUT. For this, use a 3-core cable with a conductor cross section of 2,5mm². Connections are marked as follows "OUT / N"=Neutral, "GND"=Earth, "OUT / L"=Live or Active.

Caution: High voltage can be at the AC output, ensure the unit is not connected when making AC connections.

D.3.3 Connection to the AC INPUT

The AC input supply from the electricity grid or from a generator must be connected to the screw terminals AC INPUT. For this use a 3-core cable with a conductor cross section of 2,5mm². Connections are marked as follows "IN / N"=Neutral, "GND"=Earth, "IN / L"=Live or Active.

D.3.4 Connect the Solar modules: SOLAR IN +/-

Solar modules are connected on these terminals. **Under no circumstances should any other energy source i.e. wind generator be connected to these terminals.**

Depending on the power of the modules, the cable cross section should be 2.5 up to 6mm². Before connecting it is necessary to check with a Voltmeter that the voltage of the Module meets the following values:

Invertek DAI -1500C -12xx / DAI - 3000C -12xx 17-25V / 30A

Invertek DAI -1500C -24xx / DAI - 3000C - 24xx 34-45V / 30A.

D.3.5 Connection to Aux1 & AUX2:

On these three terminals is a potential free change-over contact capable of switching a maximum current and voltage of 16A/250V ac. The “ multi-display “ on the front of Combi can show the status of these contacts.

D.3.6 Connection to Remote control unit (optional):

The Remote control unit RCC-A is connected in the “Remote control” of front panel with a RJ11 / 6 connector. The Remote Control can be plugged IN at any time. Push in the connector, without forcing it, until you hear the “click:”, now the connector is locked in place. The same applies to the plug at the Remote control unit. The length of the cable for the Remote control should not exceed 15m, is comes standard with 3m cable.

E. Operating

E.1 Front Panel Display And Operating Description

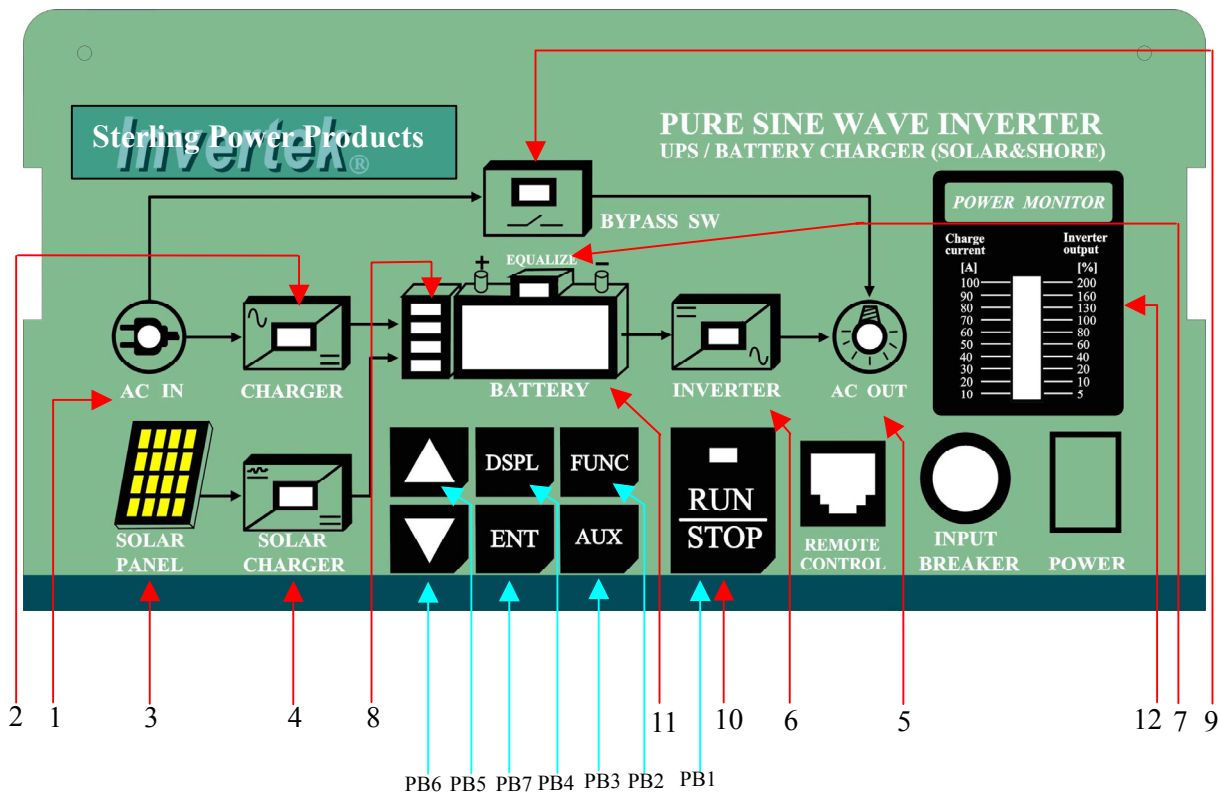

E.2 Push buttons

Push buttons	Name	Description
PB1	RUN/STOP	RUN/STOP key
PB2	FUNC	k Operation mode select key.
PB3	AUX	Auxiliary contract (aux1, aux2) Manual / Active change. And Function programming key
PB4	DSPL	Multi-display select key
PB5	UP (Δ)	Δ Increment key.
PB6	DOWN (∇)	∇ Decrement key.
PB7	ENTER	Data write key.

E.3 LED INDICATOR:

LED	Name	L ED ON	LED Blink	LED OFF
1	AC IN	1. Input voltage normal, and position "transfer Voltage Level" (150VAC~240VAC) 2. Input voltage frequency range in between(45~60Hz)	Has input power, but voltage or frequency is not in the allowance range.	No input power
2	CHARGER	Green : Battery charger is working.	Green Blink : Battery charger is standby. Orange Blink : Battery charger is disable.	-----
3	SOLAR PANEL	Solar module is delivering energy.	-----	1. Solar module aren't connect or 2. Day or Night / (cloudy day)
4	SOLAR CHARGER	Solar charger is working.	-----	Solar charger is disabled.
5	AC OUT	There is voltage at the "AC OUT" terminal.	No voltage at the "AC OUT" terminal.	-----
6	INVERTER	Green : Inverter is working.	Green Blink : Inverter is standby Orange Blink : Inverter is disable.	-----
7	EQUALIZE	In Equalize charging Process	-----	Disable Equalize charging function
8	BATTERY	Approx state of charge or discharge of Battery.		
9	BYPASS	Green : BYPASS switch is active AC IN voltage is being sent directly to AC OUT terminal	Green Blink :BYPASS switch standby. Orange Blink : BYPASS switch disable	-----
10	RUN/STOP	Green : Invertek turn on. Red : Invertek turn off.	Red Blink : Auto-Restart is in use	-----

<p>11</p>  <p>LED 9.1 LED 9.2 LED 9.3</p> <p>LED 9.4 LED 9.5 LED 9.6</p> <p>Display monitoring values or set values of each parameter.</p>	<p>MULTI-DISPLAY</p>	<p>LED</p>	<p>In Inverter Mode</p>	<p>In Charger Mode</p>
	9.1	Battery Voltage	Battery Voltage	
	9.2	Output Voltage	Input Voltage	
	9.3	Output Frequency	Charging Phase	
	9.4	AC output current	Battery charging current	
	9.5	Indicator of parameter setting or modify or monitor.		
	9.6	Indicator of error message		
	<p><i>Uut</i> : Battery under voltage trip.</p> <p><i>out</i> : Battery over voltage trip.</p> <p><i>olt</i> : AC out overload trip.</p> <p><i>oht</i> : Heatersink overtemperature trip.</p>			
<p>12</p>	<p>POWER MONITOR</p>	<p>Displays the value of the output power in % of max continuous power (in Inverter Mode) and the charge current in Amps. (in Charger Mode) In this mode the 200% LED indicate that power sharing is in use.</p>		

System Adjustments

To adjust any of the unit's preset parameters (factory/default settings are highlighted in dark blue in each function box) the unit must be in STOP mode! Select the function you wish to change from the list of light blue boxes below. Select the parameter in the box you wish to change. For example, if you wish to switch the power saver function off, you find that the power saver function is attached to **Fn02** (function 2) and that selection **2** means "off". To select this desired option go to the main key pad on the front of the unit. Push the pad marked **FUNC** (function) for 2 seconds and use up/down keys to scroll through the functions. (The display will show **Fn00** up to **Fn09**.) Stop at the function you require. (For power saver stop at **Fn02**.) With **Fn02** on the screen push **ENT** ("enter") on the keypad and use the up/down arrows to select the parameter required. The display will show from **00** to **06** (depending on which parameter you wish to change). Then select the parameter number you wish (in this case the power saver off function which is **2**), by using the up/down keys and push the **ENT** key to enter that selection. After the selection has been made the display will show **End** and this will complete the parameter change. Then press **DSPL** to return to the function heading (one level upwards). Either continue to adjusting the next function or press **DSPL** again to return to the voltage display mode. The unit will also automatically return to the voltage display after about 20 seconds if left alone. **Don't forget to return to RUN mode!**

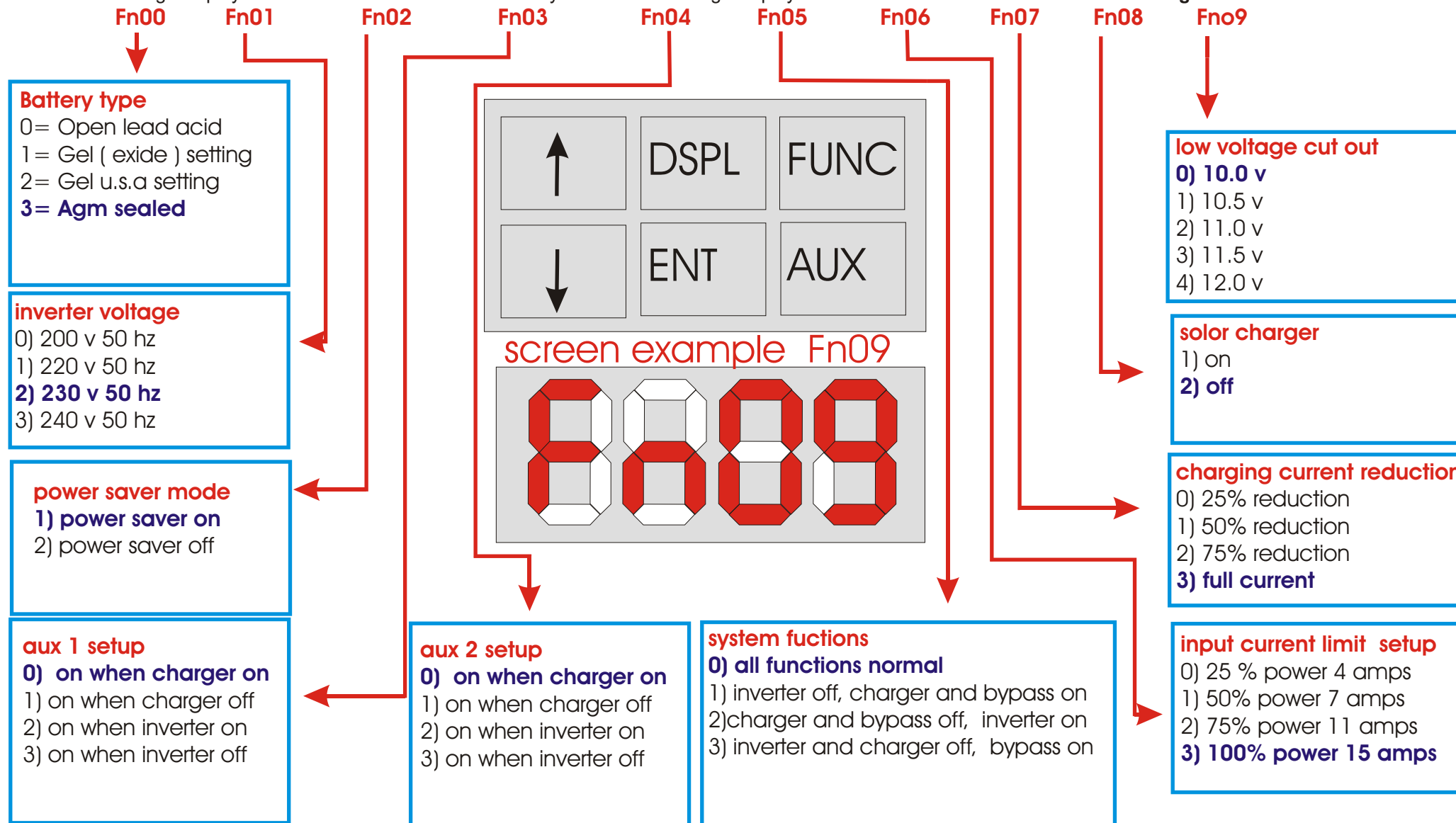

E.7.1 The Inverter

The Inverter section of the unit produces a high quality Sinewave output, the quality of this output is compatible with any appliance, Thanks to the generous dimensioning of the unit , you can operate appliances requiring higher power than the nominal power of the unit for a short time. The unit provide up to 3-times the nominal power to start motors etc.

E.7.2 Power saving function (Fn02)

In order to avoid unnecessary discharge of the battery, the inverter switches OFF automatically if no AC power is being used. The unit switches ON automatically again if an AC load is switched ON. The AC Out LED blinks if the inverter is in "Power Saving-Mode"

If the "Power Saving-Mode" is not wanted, set the Fn02 "DISABLE" function. This will keep the unit running continuously, but will also discharge your batteries quicker.

E.7.3 Overload

If the unit is overloaded for too long or too heavily, it switches off. The "Multi-display" will show "OL" and the "RUN/STOP" LED will RED Blink. After approximately 10 seconds the Inverter switches on automatically. If the unit is overloaded four times in quick succession, then it no longer switches back on automatically. The "RUN/STOP" LED remains lit, and the multi-display show "OL". Press the push button 1(PB1) "RUN/STOP" in order to switch the unit back ON.

E.7.4 Overheating (Over Temp)

If the Inverter has been overload for a long time or it has been working in a high ambient temperature, it will switch OFF. The "Multi-display" will show "OH" and the "RUN/STOP" LED RED blinks. After cooling down, the inverter switches back on automatically. One minute before the inverter switches off due to high temperature a buzzer will be heard. If the Auxiliary Contact has been programmed for "Over Temp" then the contact will be active when the buzzer sounds. This could be used for example to start an emergency back up generator, creating a no break energy supply.

E.7.5 Battery Condition

Deep discharging of batteries leads to high losses in capacity and early aging. That is why the unit will constantly monitor the battery condition. When battery voltage gets too low the Invertek switches OFF. The multi-display will show "LVL" or "LVL" (Low voltage cut out P-12) the "RUN/STOP" LED RED blinks. When the battery voltage returns to 12.1V resp. 24.2V, the inverter switches ON automatically. One minute before the Inverter switches OFF due to low voltage a buzzer will be heard.

The low voltage is set to 11.8V resp. 23.6V. These settings are standard for most batteries. The voltage levels are maintained by the built-in Battery-Management-System of the Invertek which looks at the load and battery condition and adjusts to suit.

This setting is comparable with the levels of 10.8V resp. 21.6V, which are given for most batteries on nominal load.

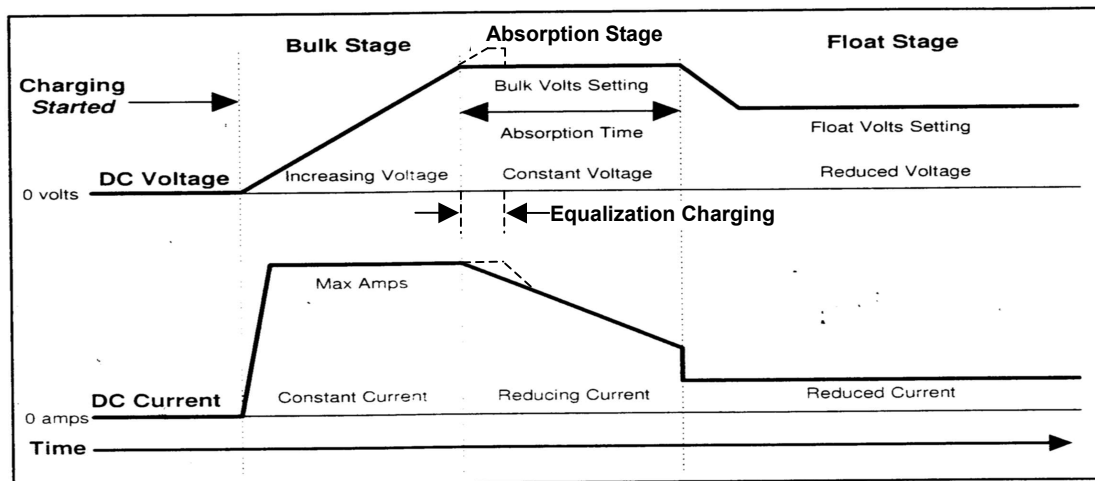

F. Disabling Functions (Fn05)

Each different function, charger, inverter and transfer can be disabled. This is useful for specific applications which are required to disable some of these three functions. If you press the "FUNC" button for more than 2 seconds you can have access to the different possibilities shown in the following diagram,. In programming mode the display only shows the different types of program with the "Charger", Transfer" and "Inverter" functions. To change the type of programming press the "△ or ▽ " button until the LED corresponding to the desired function is lit, in to the table below, After 10 seconds or press "DSPL" button the Invertek will exit the programming mode and function with the new programming,. In normal user mode, the disabled functions are displayed by a orange blinking LED.

F.1 Diagram of the different mode

Indicates an off LED Indicates a orange blinking LED Indicates a lit green LED

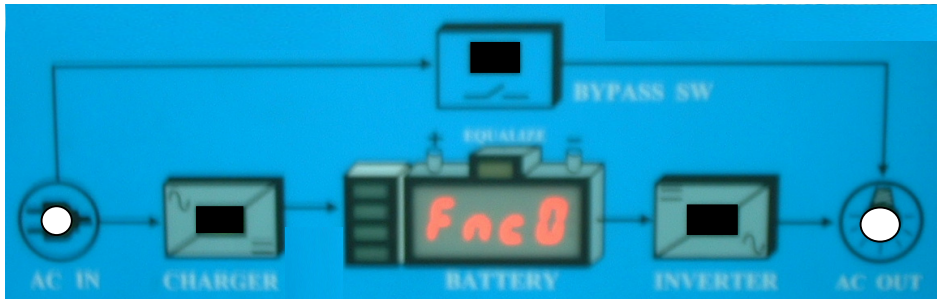

All the functions are enabled. This is factory setting.

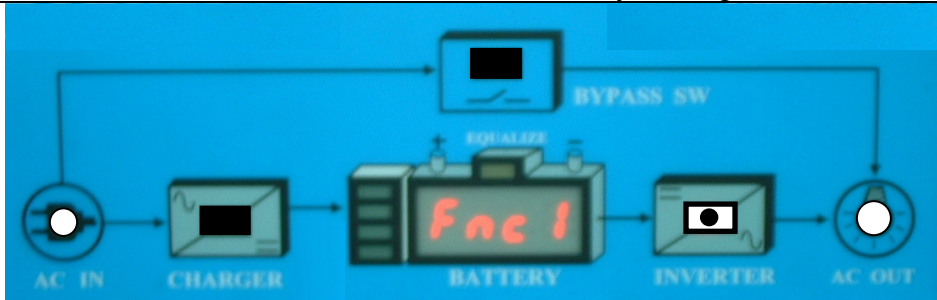

The inverter is disabled. Only the Bypass switch and charger will work normally.

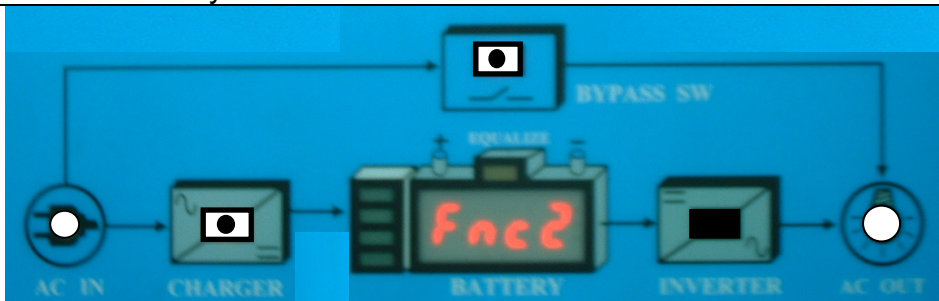

Charger and Bypass switch are disabled. The inverter will work continuously even if there is a correct AC voltage at the input.

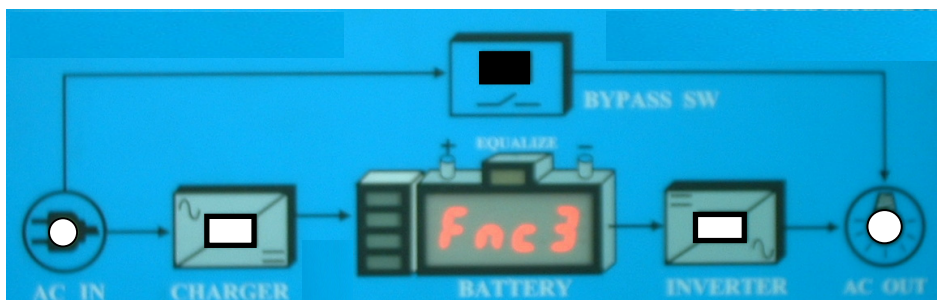

Inverter and charger are both disabled. Only the Bypass switch function is enabled in input and frequency is OK.

G. Charger Information

G.1.1 Charging Cycle

The fully automatic battery charger can be adjusted so that most major battery types can be charged to the maximum,

As soon as the minimum AC voltage is available at the AC input ("AC IN" LED is lit), the Battery Charger is switched on automatically ("CHARGER" LED is lit). The battery is automatically charged to match the pre adjusted voltage levels and charge current. Thanks to the sophisticated and intelligent Floating Charge System, the batteries can be left in charge mode for unlimited time.

During the charging cycle, the AC loads are continually supplied with power from the incoming AC voltage source. ("AC OUT" LED is lit).

G.1.3 Input current repartition (Power sharing Fn06)

To manage the power available on the AC INPUT the unit is equipped with a system usually called "Power sharing" or INPUT power distribution. With this feature it is possible to limit the AC INPUT current assigned to the charger. The more current used by the AC load, the less power is given to the charger. Priority for the AC Loads. When power sharing is used the red 200% LED on the power monitor is lit to show that the battery charging is being limited.

G.1.4 Set the charging current (Fn07):

The maximum charging current of the battery can be adjusted by function Fn07. The charging current should be set to approximately 10-15% of the battery capacity (at C10). This means that the charging current for a battery with 300Ah should be set between 30-45A. The charging current is displayed on the "multi-display" or "CURRENT MONITOR" on the front panel

G.1.5 Battery Condition:

The built in microprocessor features a specially developed algorithm (formulae) which calculates the actual state of charge (SOC) of the battery and displays it on LED-8. The Equalize LED-7 is lit when the system is performing an equalization charge. The SOC displayed should be used as a guide only, for batteries which are not sealed, use a hydrometer to determine the exact SOC.

For safety reasons:

Make sure that the setting of the charger matches your battery type! The correct charging levels are critical for safe functioning and long life of the battery.

G.2 The Transfer system

When an AC voltage is present at the AC IN of the unit , the “AC IN” LED is lit. When this voltage matches the Parameter P-06 value set, and the frequency is between 44Hz and 65Hz, then this power is transferred directly to the AC load and the battery charger section . The “TRANSFER” LED is lit to indicate this has happened. The inverter is then switched off and the battery charger switched on. This process is automatic and should not be noticed by the load, at worst a slight flicker may be seen in lights.

The maximum current of the Bypass switch is 60A (CUxx3500) resp. 30A (CUxx1700). That means through this system AC loads of up to a maximum of 7000 W (CUxx3500) or 3500W (CUxx1700) can be operated. When the Battery Charger is working, part of this power is used for the charging according to the power sharing settings.

The Transfer system is protected against overload with an automatic breaker on the AC Input side of the unit . If the system has been overloaded the Input breaker will pop-out. To put the automatic safety system back in to operating you must push this breaker for reset.

Note: In inverter operation the unit generates a pure sinewave and quartz stabilized output voltage. However, when the unit is transferring power from the grid or a generator the voltage and quality of the power running the AC load will be the same as that coming from the grid or generator. The unit cannot modify the incoming AC supply.

G.3 The solar charge regulator

The unit has a built-in solar charge regulator. To charge the batteries solar modules can be connected to the terminal SOLAR IN +/- . The built-in regulator is a shunt regulator with a maximum input current of 30A for all series products. The operating voltage of solar modules to be connected must match the actual operating voltage of the unit and never exceed the max. rated value.

Under no circumstances should any other charging sources such as a wind-generator be connected at the input of the solar charge regulator. The Solar Charge Regulator works automatically and is always in operation. As soon as the energy is delivered from the solar charge regulator, the “SOLAR CHARGE” LED is lit and the batteries are being charged, The solar charge regulator works even when the battery charger is functioning. The method of operation is a 3 or 4 step charging process, the same as the battery charger. The function is described in the section on battery charger. The programming and the adjustments are carried out in accordance with the section on battery charger. The programming and the adjustments are carried out in accordance with the same conditions. Check with your battery supplier which adjustments must be carried out for your battery.

I. Auxiliary Contacts

In the unit there are two built-in programmable power relays (AUX1, AUX2). The potential-free change-over contact of this power relay is connected to the screw terminals (AUX1 NO-NC-COM, AUX2 NO-NC-COM)

Maximum Contact load: -230Vac / 5Amp-30Vdc/7Amp

In the factory we program this output to be active when one these situations are detected:

- Over temperature
- Overload
- Over or under voltage of batteries
- Unit is turned off manually or with a fault, "RUN/STOP" LED RED lit

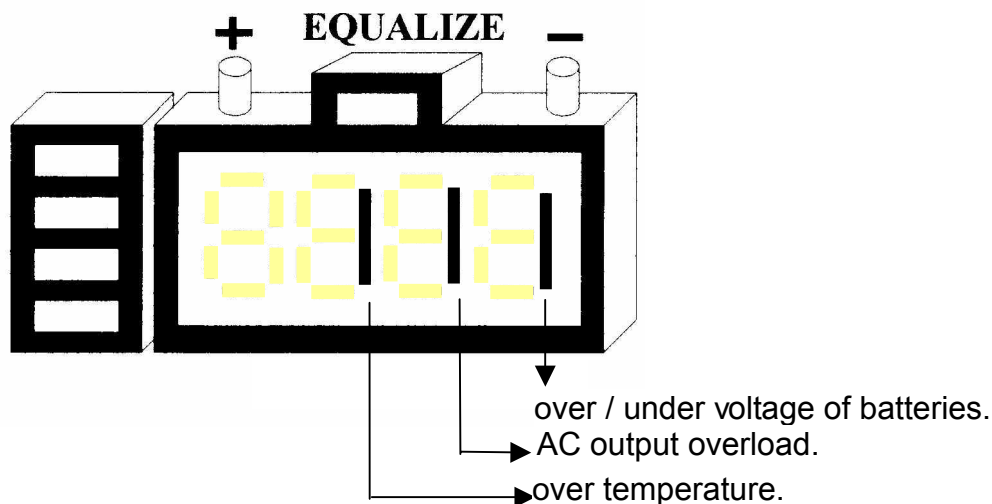

J. The Remote control unit

As an option, a Remote control unit can be connected to the unit. All operating controls and displays are available on the Remote control unit, The Remote control is supplied with a 3m long cable. It can be lengthened to 15m The Remote control is suitable for surface mounting on the wall or on to a switch board. It is fixed with 2 screws. The unit can also be programmed with the Remote control. The output currents and the charging currents are displayed on the Remote control.

J.1 The Temperature sensor

Charging voltages of lead-acid batteries can change depending on temperature. To correct the operating voltages according to the actual temperatures, a temperature sensor can be connected to the unit.

The compensation through the sensor is $-3\text{mv}/^{\circ}\text{C}/\text{Cell}$.

L. Programming Aux Contacts (AUX1, AUX2)

L.1.1 Principle

The Auxiliary unit can be basically programmed for any operating situation of the unit which is indicated with a LED. The programming is possible for one or more operating situations. If the contact is programmed for many situations, it is activated as soon as the unit finds itself in any one of the programmed situations.

L.1.2 Example

L.1.2.1 Auxiliary contact as generator starter

When in the programming of the Auxiliary Contact, the State of Charge (SOC) LED's (LED 8) can be used as a condition, then you must take note of the following requirements.

If you have to start an emergency back-up supply with a battery having a certain SOC, then two SOC levels must be programmed. The first (i.e. Battery 25% LED) for the starting or activating the Auxiliary Contact and the second (i.e. Battery 100% LED) for stopping or deactivating the Auxiliary Contact. By programming in this way the Auxiliary Contact starts with the lowest set condition and stops when it has reached the highest programmed condition through charging.

L.1.2.2 Auxiliary Contact as Twilight Switch (With solar charger option)

The Auxiliary Contact can also be used as a twilight switch, i.e. for automatically operating exterior lighting. Solar modules connected to the unit will measure the light intensity. If the unit is operating without solar modules and a twilight-switching function is desired, you can connect small solar cells with the nominal voltage of the unit to the SOLAR terminals for the purpose of measuring the light intensity. To function as a twilight-switch the Auxiliary Contact must be programmed so that the condition "SOLAR CHARGE" LED is active. Programming must be carried out in steps and in accordance with the description for the programming of the Auxiliary Contact.

L.1.3.3 Manual operating of Auxiliary Contact:

The Auxiliary Contact can be operated manually at any time by pressing the "AUX" button. The "Multi-display show *!HON (2HON)* to indicate that the Contact is manually operated. By pushing the "AUX CONTACT" button again, the Contact is deactivated. Multi-display show *!HOF(2HOF)*. By pushing it a third time, automatic functions are restored and Multi-display show *!HON (2HON)*.

M. Maintenance

Periodic maintenance is important to avoid potential problems. Every six months disconnect all power in and out from the system. Thoroughly clean and check all battery connections within the battery bank and to the unit . Ensure all connections to the unit are tight. Ensure the vents at the top and bottom of the unit are clear of any debris, such as mud wasps, severe dust build ups etc.

Other than this, you should enjoy years of trouble free operation form your unit.

N. Specifications

MODEL	DAI-1500C-12xx DAI-1500C-24xx	DAI-3000C-12xx DAI-3000C-24xx
-------	----------------------------------	----------------------------------

1. Inverter Section

Nominal battery voltage	12V / 24V	12V / 24V
Input voltage range	9.5-16V / 19-32V	9.5-16V / 19-32V
Output voltage	200~240Vac / 100~120Vac	
Output frequency	50Hz / 60Hz	
Total Harmonic Distortion output THD	< 2%	
Dynamic behavior 0→100%	0.5 ms	
Nominal power (W)	1500W	3000W
Maximum power 30 min (W)	1700W	3500W
Maximum power 3 min (W)	2300W	4500W
Maximum power 5 sec (W)	3000W	6000W
Maximum load	Up to short circuit	
Asymmetrical load max.	Up to nominal output power	
Overload and short circuit protection	Automatic disconnection with 5 time restart attempt	
Overheating temperature protection	Acoustic warning before shut-off. Automatic restart	
Power factor range	0.1-1	
Power saving function	(disable / enable)	
Maximum efficiency	85-90%	

2. Battery Charger Section

Maximum input voltage	265 Vac, 350 V peak	
Minimum input voltage	Adjustable 150-230Vac	
Input Frequency range	45~63Hz	
Charging current adjustable	0-50A / 0-35A	100A / 0-70A
Setting of AC INPUT current POWER SHARING	0 to 15A	

3. Solar Charge Regulator-Floating

Maximum Poen Circuit Voltage	25V	45V
Maximum charging current	30A	30A

4. Battery Charge Montitoring (25°C)

*Low battery disconnection voltage	10.8V / 21.6V	
*Low voltage	10.8V~12.0V (11.6V) / 21.6V~24.0V (23.2V)	
*End of charge cycle voltage	14.2V~15.0V (14.4V) / 28.4V~30.0V (28.8V)	
*Equalization voltage every 25 cycles	15.1V~15.5V (15.3V) / 30.2V~31.8V (30.6V)	
*Floating voltage	13.3V~13.7V (13.5V) / 26.6V~27.4V (27.0V)	
*Absorption charge time	0~4h (2h)	
Temperature compensation (Option)	3mV / °C cell	

5. General date

AC By pass time (UPS-Mode)	20ms max	
Potential free Multifunction contact	5A-250Vac / 7A-60V dc x 2	
Max Current at Transfer relay	30A / AC 220V	60A / AC220V
Operating temperature	-20°Cto +55°C	
Fan forced ventilation	From 45°C / over 75°C will be trip	
Protection index IP	IP20	
Weight	15kg	22kg
Dimension H*W*L (mm)	350x285x185	510x285x185

Remark : * () Factory settings

Free Manuals Download Website

<http://myh66.com>

<http://usermanuals.us>

<http://www.somanuals.com>

<http://www.4manuals.cc>

<http://www.manual-lib.com>

<http://www.404manual.com>

<http://www.luxmanual.com>

<http://aubethermostatmanual.com>

Golf course search by state

<http://golfingnear.com>

Email search by domain

<http://emailbydomain.com>

Auto manuals search

<http://auto.somanuals.com>

TV manuals search

<http://tv.somanuals.com>