

STERLCO TEMPERATURE CONTROL UNIT
SERVICE AND INSTRUCTION MANUAL
MODEL K-026-D

Engineered and Manufactured by INDUSTRIAL CONTROL DIVISION of STERLING, INC.
5200 West Clinton Avenue; P.O. Box 23435 Milwaukee, WI 53223-0435
Manufacturers of Temperature Control Equipment Since 1916

Please note that our address and phone information has changed. Please reference this page for updated contact information.



These manuals are obsolete and are provided only for their technical information, data and capacities. Portions of these manuals detailing procedures or precautions in the operation, inspection, maintenance and repair of the products may be inadequate, inaccurate, and/or incomplete and shouldn't be relied upon. Please contact the ACS Group for more current information about these manuals and their warnings and precautions.

Parts and Service Department

The ACS Customer Service Group will provide your company with genuine OEM quality parts manufactured to engineering design specifications, which will maximize your equipment's performance and efficiency. To assist in expediting your phone or fax order, please have the model and serial number of your unit when you contact us. A customer replacement parts list is included in this manual for your convenience. ACS welcomes inquiries on all your parts needs and is dedicated to providing excellent customer service.

For immediate assistance, please contact:

- North, Central and South America, 8am – 5pm CST +1 (800) 483-3919 for drying, conveying, heating and cooling and automation. For size reduction: +1 (800) 229-2919.
North America, emergencies after 5pm CST (847) 439-5855
North America email: acsuscanadacustserv@corpemail.com
- Mexico, Central & South America
Email: acslatinamericacustserv@corpemail.com
- Europe, Middle East & Africa +48 22 390 9720
Email: acseuropecustserv@corpemail.com
- India +91 21 35329112
Email: acsindiacustserv@corpemail.com
- Asia/Australia +86 512 8717 1919
Email: acsasiacustserv@corpemail.com

Sales and Contracting Department

Our products are sold by a worldwide network of independent sales representatives. Contact our Sales Department for the name of the sales representative nearest you.

Let us install your system. The Contract Department offers any or all of these services: project planning; system packages including drawings; equipment, labor, and construction materials; and union or non-union installations.

For assistance with your sales or system contracting needs please Call:

North, Central and South America +1 (262) 641-8600 or +1 (847) 273-7700 Monday–Friday, 8am–5pm CST

Europe/Middle East/Africa +48 22 390 9720

India +91 21 35329112

Asia/Australia +86 512 8717 1919

Facilities:

ACS offers facilities around the world to service you no matter where you are located. For more information, please visit us at www.acscorporate.com

United States:

ACS Schaumburg – Corporate Offices

1100 E. Woodfield Road
Suite 588
Schaumburg, IL 60173
Phone: + 1 847 273 7700
Fax: + 1 847 273 7804

ACS New Berlin – Manufacturing Facility

2900 S. 160th Street
New Berlin, WI 53151
Phone : +1 262 641 8600
Fax: + 1 262 641 8653

Asia/Australia:

ACS Suzhou

109 Xingpu Road SIP
Suzhou, China 215126
Phone: + 86 8717 1919
Fax: +86 512 8717 1916

Europe/Middle East/Africa:

ACS Warsaw

Ul. Działkowa 115
02-234 Warszawa
Phone: + 48 22 390 9720
Fax: +48 22 390 9724

India

ACS India

Gat No. 191/1, Sandbhor Complex
Mhalunge, Chakan, Tal Khed,
Dist. Pune 410501, India
Phone: +91 21 35329112
Fax: + 91 20 40147576

MODEL K-026-D

INDEX

	<u>PAGE</u>
INTRODUCTION	i
Description	1-5
Controls	5-7
INSTALLATION	7
CIRCULATION	8
Flow Diagram (K-026-D) Dwg. C-682-04326	
PRELIMINARY OPERATION	9
Start-Up Procedures (K-026-D)	9
Operation (K-026-D)	9
Heating (AUTO)	9-10
Cooling (MANUAL)	10
Return Fluid to Tank	11
ELEMENTARY DIAGRAM - K-026-D	C-682-30541
FLOW SCHEMATIC - K-026-D	B-682-04266
PREVENTATIVE MAINTENANCE	12-13
TROUBLE SHOOTING	14
UCON Heat Transfer Fluid	F-43170A
Fenwal Temperature Controller	2.20H
Viking Pump	TS 141.1
Rotary Pump	TS 000
Pump Parts List	
CONTACTOR	Bulletin Mfg.
STARTER	Bulletin Mfg.
HEATER ELEMENT	Bulletin Mfg.
FUL-FLO VALVE	1" & 1-1/4"
SPARE PARTS LIST	636
WARRANTY	

MODEL K-026-D

INTRODUCTION

We are pleased to provide a Temperature Control Unit for your application. It is built by skilled craftsmen with the most modern and precision machines available today. The simplicity of design and compactness engineered into the unit resulted in less maintenance and less floor space.

The Sterlco High Temperature Control Unit, designed and tested over a period of many years, represents one of the most significant advances ever in the field of self-contained, closed systems - portable units for heating synthetic fluid and circulating it at controlled temperatures - through molds, rolls or jackets of processing equipment.

The Model K-026-D is a complete dual-zone heating, cooling and circulating control unit, with one delivery and one return line, per zone, plus a common water supply line and drain line for cooling.

These standard units may have many variations of optional features added to them relative to the customer's application or specific desires.

The illustrations used are to help you identify certain parts by name and to understand our explanations - which will assist you later on in the Trouble Shooting sections.

The unit is warranted against defects in materials and workmanship for one year from date of shipment.

Any Sterlco Unit which has been used contrary to specific operation instructions or materially altered will not be covered by this warranty. Final determination of defects must be made at Sterling, Inc.

The units can easily be moved from one location to another, simply by removing the circulating connection lines.

By following the instructions in this manual and treating your equipment with care and respect due any precision equipment, you will be rewarded with years of uninterrupted, trouble-free service.

CAUTION! THIS EQUIPMENT MUST NOT BE USED WHILE UNATTENDED!

MODEL K-026-D

DESCRIPTION:

FLUID HEATING:

Heating of the fluid is accomplished through the specially designed low watt density electrical immersion heater inserted into the heater tank. The immersion heater temperature is controlled by the indicating thermostat mounted on the front of the control panel. A safety thermostat is installed on the electrical panel; this safety thermostat is set at 570°F. during testing at the factory. The safety thermostat has its own sensing bulb inserted in the heater flange completely separated from the control system.

The Model K-026-D can be supplied with either 9, 12, 18, 24, or 36 KW low watt density immersion heaters. The higher the ratings, the faster the fluid will heat up relative to the setting of the indicating thermostat.

5" heater tanks are used for 12 KW - 6" heater tanks are used for 18, 24, and 36 KW.

KW ratings of the immersion heaters are rated at the following standard voltages:

18 KW	61,452 BTU/hr.
-------	----------------

PUMP:

Circulation of the fluid is controlled by a slow speed, high temperature, positive displacement pump, which is belt-driven by the electric motor. It may be supplied with a drip return pump as an option.

COOLING:

A specially designed shell and tube type heat exchanger of copper nickel with stainless steel expansion joints is provided as standard equipment in those units requiring cooling. The standard size offered is approximately 4 sq. ft. in surface area.

FUL-FLO VALVE:

The purpose of this valve is a safety device that in the event any line external of the unit has been obstructed and the pressure in the line exceeds the set pressure on the pressure gauge, the Ful-Flo Valve will open and divert the fluid back into the return line.

MODEL K-026-D

CIRCULATING CONNECTION LINES:

The Model K-026-D is equipped with a heat exchanger - a water supply line rated at 65 PSI maximum is required and a drain line is necessary. (CAUTION: The drain line should be directed away from personnel and flow directly into an open drain. This drain line must not have any back pressure or obstructions.)

Requirements for water connections are:

<u>SUPPLY</u>	<u>DRAIN</u>
3/4"	3/4"

Sterling, Inc. stocks the recommended types of Flexible Metal Hoses in many lengths (our P/N A-572-16969-00). Please state length requirements when ordering.

Hoses must be adequate to withstand the maximum temperatures and pressures at which the unit is to be operated.

Delivery and return lines of the unit are 1" female pipe thread for flow rates thru 24 GPM and 1-1/2" female pipe threads for 30 or 50 GPM flow rates. These lines are located at the left side of the unit.

Hoses, fittings, and channel connections in the mold or other equipment being controlled should be at least 3/4" in order not to restrict the flow of fluid through the circuit. If the flow is restricted by too small of connecting hoses or hoses with excess bends, loops, etc., the pressure relief valve will open and the flow through the internal circulating lines will be greatly reduced.

If your mold has already been made with serpentine channeling, we would like to suggest modification as shown in Dwg. #A-682-03844 and using a manifold preferably of 3/4" NPT pipe.

In order to eliminate any back pressure, it would be advisable to drill holes at points 'A' and tap for 3/4" pipe.

Several parallel runs are far more practical than one long serpentine run and in many cases, can make a difference between precise control and erratic operation.

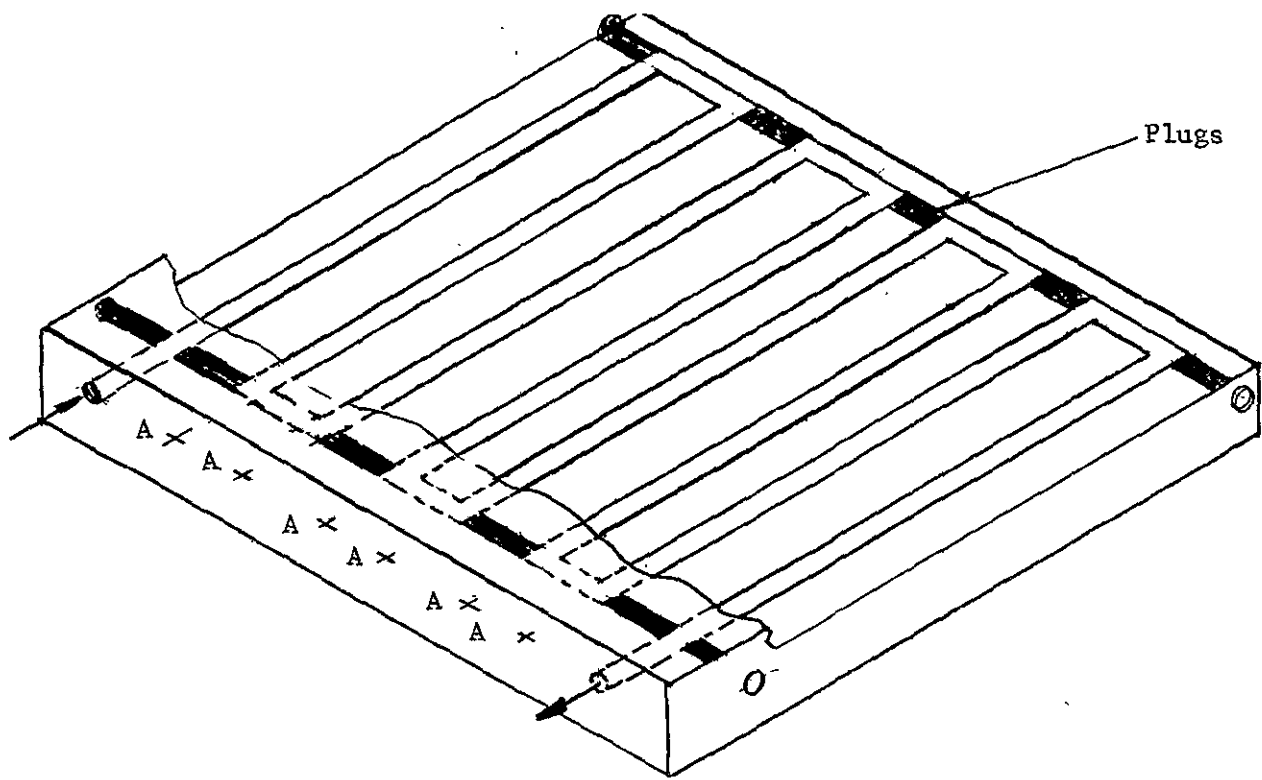

Modification of Platen
For Manifold

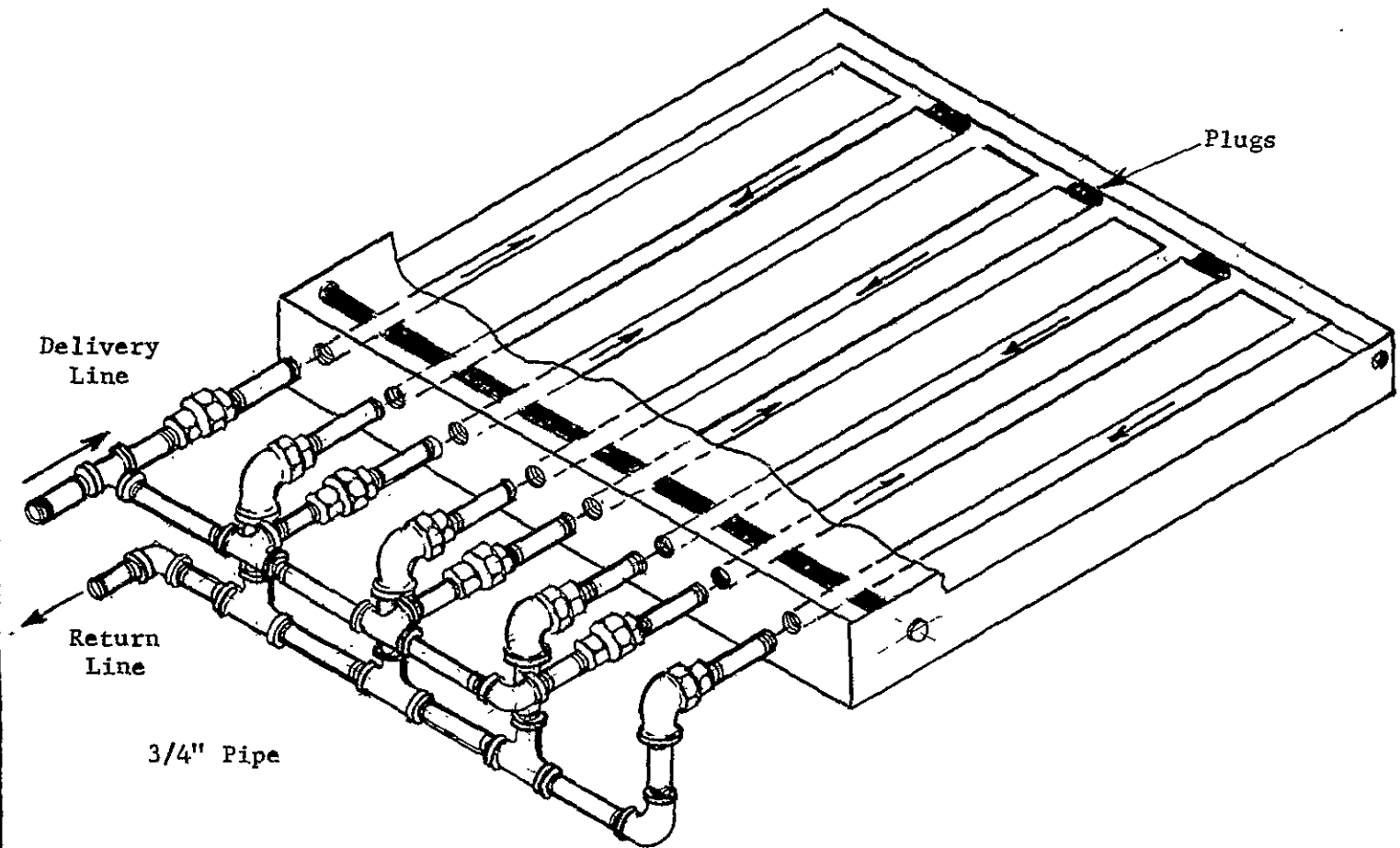

Fig.1

A-682-03844

MODEL - K-026-D

HEAT TRANSFER FLUID: (See UCON Bulletin #F-47431 Material Safety Data Sheet

We highly recommend the use of UCON Type 500 as being the most suitable for outstanding service and dependability as heat transfer fluids for our units. This fluid is a polyalkaline glycol derivative. It differs in chemical nature and in performance from natural oils and from other synthetic heat transfer fluids. Heat transfer fluids are not compatible, they should not be mixed. In a closed vented system, this fluid has remained substantially unchanged after many months at temperatures up to 500° F.

Our warranty is based upon the use of this fluid.

CAUTION! PROLONGED OR REPEATED EXPOSURES TO VAPORS GENERATED AT HIGH TEMPERATURES MAY RESULT IN EYE AND RESPIRATORY TRACT IRRITATION AND IN THE INHALATION OF HARMFUL AMOUNTS OF MATERIAL.

GENERAL (MECHANICAL) ROOM VENTILATION IS SATISFACTORY FOR USE AT LOW TEMPERATURES. IF USED AT HIGH TEMPERATURES, SPECIAL LOCAL VENTILATION IS RECOMMENDED AT POINTS WHERE VAPORS CAN BE EXPECTED TO ESCAPE TO THE WORKPLACE AIR. REFER TO THE ENCLOSED MATERIAL SAFETY DATA SHEET FOR ADDITIONAL SAFETY PRECAUTIONS.

CHANGE FLUID: CAUTION! FLUID MUST BE AT ROOM TEMPERATURE BEFORE BEING CHANGED!

The fluid will eventually lose it's clarity and begin to darken. This change in color is a normal reaction.

The fluid should last from one to three years or longer - depending upon operation temperatures. When viscosity has increased 20-25%, the fluid should be discarded and new fluid added.

The viscosity increase (thickening) indicates an accumulation of soluble decomposition products. Prolonged use of thickened fluid will result in malfunction of the entire system.

Should the user choose to disregard our recommendations, we cannot assume any responsibility for the successful operation of the system, or for any damage or malfunction which might result. Our manufacturing warranty covers only those installations using the recommended fluid.

The fluid is contained in the expansion tank which holds approximately (8) gallons.

The internal piping and the heater tank requires about (5) gal. of fluid.

Additional fluid should be available to fill the connecting lines, plus the channels, etc.

With the system purged and properly filled, only 1" to 2" should be visible in the sight gauge glass. This provides capacity in the expansion tank for expansion and for fluid when the pump is reversed and fluid withdrawn from the system.

CAUTION! EXPANSION TANK MAY NOT HAVE ADEQUATE VOLUME TO HOLD TOTAL SYSTEM CAPACITY.

MODEL K-026-D

VENT CONNECTIONS:

On the left side of the units is a fill connection and "VENT CONNECTION".

At higher temperatures where the liquid may give off appreciable vapors or fumes, adequate ventilation should be provided on this connection. This vent connection must not be closed at any time.

If a long vent is required, it is suggested that the vent be trapped near the exit to collect the moisture which can develop on the vent when the unit is cooled.

CONTROLS:

Model K-026-D has five basic electrical controls, plus a Pressure Vacuum Gauge and manual Temperature Controller.

COOL-OFF-AUTO	STOP SWITCH	TEMPERATURE CONTROLLER
HEAT INDICATOR LIGHT	(PUSHBUTTON)	SAFETY THERMOSTAT
REVERSE SWITCH	PRESSURE GAUGE	
(PUSHBUTTON)		

HEAT - COOL INDICATOR LIGHT

COOL - OFF - AUTO SWITCH

COOL - OFF - AUTO SWITCH:

When the control knob is placed in the "OFF" position, the unit is neither heating or cooling, but is circulating.

When the control knob is placed in the "AUTO" position, the unit is heating or cooling depending upon the temperature control setting.

HEAT - COOL INDICATOR LIGHT: (K-026-D)

If the unit is in the heating cycle - the indicator will illuminate "RED".

If the unit is in the cooling cycle - the indicator will illuminate "WHITE".

COOL POSITION:

When the control knob is placed in the "COOL" position, the unit is in manual "COOLING" at all times.

MODEL K-026-D

FORWARD PUSH BUTTON:

When this switch is depressed momentarily, the motor starter is energized and the pump runs (clockwise rotation) in the forward position, as viewed from the shaft end.

The circuit is "held-in" by the motor starter interlock, which provides low voltage protection. This interlock is used to provide power at the heating circuit on-off switch.

REVERSE PUSH BUTTON: CAUTION! NEVER REVERSE PUMP WITH HOT FLUID. COOL FLUID TO ROOM TEMPERATURE BEFORE REVERSING.

When this button is depressed and held, the reverse motor starter is energized and the pump runs in reverse (counter clockwise) rotation (viewing shaft end). The heating circuit is inoperable. With the Return Line Valve closed - and the Blow-Off Valve open - fluid is drawn from the system to the expansion tank. CAUTION! EXPANSION TANK VOLUME MAY NOT BE ADEQUATE TO HOLD TOTAL SYSTEM CAPACITY!

STOP - PUSH BUTTON:

When this switch is depressed, the electrical control (115V) system is deactivated.

PRESSURE GAUGE:

This compound pressure gauge has dial readings in inches of mercury, vacuum and pounds per square inch pressure. It is also calibrated in Kg/cm^2 .

The Red Arrow is set to indicate pressure at which the Ful-Flo Valve is full open.

The Black Arrow indicates the actual pressure the pump is developing.

TEMPERATURE CONTROLLER:

Control action of this electro-mechanical indicating temperature controller is provided through the principle of liquid change.

With a variation in temperature, the liquid in the sensing bulb, which is inserted into the delivery line, expands or contracts, causing the bellows located inside the case to actuate the switching mechanism.

The controller has an integral set stop to limit the maximum set temperature to 550°F . Turning the control knob to the right, the indicator needle (black top) will move; this is to be set at the temperature required.

The black indicator needle shows the temperature, as it slowly advances toward the set point. When the two needles are aligned - the heat will automatically shut off. (See Controller Instruction Sheet - Model 40-702)

MODEL K-026-D

SAFETY THERMOSTAT:

The adjustable Safety Thermostat is mounted in the inside of the electrical box and has its own sensing bulb which is installed in the heater tank flange bulb well on the top of the heater tank.

PRELIMINARY OPERATION

INSTALLATION:

INITIAL PROCEDURES:

This unit is supplied for three phase operation for a selected voltage. Caution must be taken to provide a correctly sized power supply to the unit. This unit must be properly grounded.

All electrical connections must be secure and should be checked before starting.

ELECTRICAL: (Ref: Wiring Diagrams)

It will be necessary to drill a hole in the cabinet for a power supply line.

<u>HEATER CAP.</u> <u>EACH CIRCUIT KW</u>	<u>TOTAL AMPS</u> <u>3/60/460</u>	<u>TOTAL AMPS</u> <u>3/60/230</u>
12 KW	31	62
18 KW	46	92
24 KW	62	124
36 KW	97	194

FILLING THE TANK WITH FLUID:

The expansion tank holds (8) gallons of fluid. The internal piping and the heater tank require (5) gallons of fluid.

Additional fluid should be added to fill the connecting lines, plus the channels in the process.

As the unit is operating in the heating cycle, the fluid expands. Caution must be taken to never over fill the tank.

MODEL K-026-D

CIRCULATION:

FLOW DIAGRAM (K-026-D See Dwg. #C-682-04326):

HEATING:

With the COOL - OFF - AUTO switch in the AUTO position and by depressing the Forward Pushbutton, the motor will run and activate the pump. The heat indicator light will illuminate "RED" when fluid temperature is below controller set point.

The fluid is drawn down to the pump by gravity feed. As the fluid is circulated through the pump, a pressure will be indicated on the pressure gauge.

The fluid travels into the bottom of the heater tank where it is heated by the immersion heater to the temperature requirements set on the controller.

As the pressure builds upon the pressure gauge and the fluid reaches the top of the tank, the heat sensor indicates the temperature on the controller.

The fluid is forced into the shell of the shell and tube heat exchanger and into the process delivery supply connecting line and circulated through the process.

NOTE: If the pressure in the line is greater than the set pressure on the pressure gauge, the fluid will by-pass the delivery to the process supply and will be diverted through the Ful-Flo (Safety Valve) back in the return line.

As it is circulated through the process, the fluid cools down slightly and is returned from the process to the return connecting line, through the strainer which collects any foreign matter, down the return line into the pump and recirculated back into the heater tank.

CAUTION: It is very important that the sight gauge glass indicates that there is an ample supply of fluid contained in the fluid expansion tank. An inch or two visible in the sight gauge glass is sufficient after the unit is properly purged.

COOLING:

Whenever the fluid temperature exceeds the controller set point the cool indicator light will illuminate "WHITE", indicating that the unit has switched to the cooling mode.

The hot fluid will flow the same way as in the heating cycle, except that the heater will be disengaged and the solenoid valve will be activated and cold water from the water supply line will flow through the solenoid valve, throttle valve and check valve into the heat exchanger, circulating through the cooling tubes inside the heat exchanger and cooling the hot fluid circulating around the cold tubes. The water is then routed out through the drain line.

MODEL K-026-D

PRELIMINARY OPERATION

START-UP PROCEDURES

- 1) Close the Return Valve.
- 2) Turn the heater selector switch to OFF.
- 3) Place a small container under the opened Blow-Off Valve to catch the fluid.
- 4) Depress the FORWARD Pushbutton. Check motor rotation by observing the pressure gauge. If a positive pressure is indicated, rotation is correct, if a vacuum is indicated, reverse two motor wire connections.
- 5) If there is any air in the lines it will come out of the Blow-Off Valve.
- 6) Allow the unit to run for a brief period to insure complete circulation. Watch the flow coming out of the Blow-Off Valve for bubbles or erratic flow.
- 7) When the fluid runs steadily, close the Blow-Off Valve.
- 8) Open the Return Line Valve.
- 9) Recheck the Sight Gauge Glass.
- 10) Position the "COOL - OFF - AUTO" switch to the "AUTO" position.
- 11) Make sure that the Blow-Off Valve is closed.

OPERATION: (K-026-D Heating & Cooling)

HEATING: ("AUTO")

- 1) Set the desired temperature on the Temperature Controller.
- 2) Turn "COOL - OFF - AUTO" switch to the "AUTO" position.
- 3) Depress the "FORWARD" pushbutton - the heat indicator will illuminate (RED) indicating that the unit is in the heating cycle.
- 4) As the fluid heats up and the heat indicator needle rises to meet the indicator set point, the indicating needle may exceed the set point slightly - when this occurs, the solenoid valve on the water supply line will open and allow cold water to enter the cooling tubes of the Heat Exchanger.

At this moment, the "COOL" indicator light will illuminate (WHITE) indicating that the unit is in the cooling cycle.

Operation: Heating ("Auto") Continued:

- 5) As the fluid cools down to below the set point, the solenoid will close, shutting off the water supply and the heater will take over again, to bring the temperature up to a controlled even heat.

COOLING:

THROTTLE VALVE:

The throttle Valve is used as a control valve to regulate the amount of cold water entering the heat exchanger. The time lapse between heating and cooling can be regulated by this valve.

If the "COOL - HEAT" indicator light switches from "COOL" to "HEAT" in rapid succession, too much cold water is entering the cooling tubes - which would result in damage to the heat exchanger.

Close the Throttle Valve to a point where a reasonable time element is established, depending upon the temperature of the process.

CHECK VALVE:

This horizontal Check Valve eliminates the back flow of water from the heat exchanger.

PRESSURE RELIEF VALVE:

This Relief Valve is rated at 150 PSI and its function is to protect the heat exchanger.

If the drain line is restricted and the pressure exceeds 150 PSI, the valve will open up to release the pressure in the line.

As soon as the pressure returns to normal, the valve will close.

MANUAL:

After the unit has been operating in the heating cycle for a length of time a fast cool-down of the fluid is required -

- 1) Position the "COOL - OFF - AUTO" switch to "COOL". This will over-ride the temperature controller and provide continuous cooling until this switch is reset.
- 2) The cool indicator will illuminate "WHITE" indicating that the unit is in the cooling cycle.

CAUTION! THIS EQUIPMENT MUST NOT BE USED WHILE UNATTENDED!

MODEL K-026-D

RETURNING FLUID TO TANK:

If the unit is to be moved from one process to another the following steps must be taken:

- 1.) Cool fluid to room temperature.
- 2.) Close the Return Line Valve.
- 3.) Open the Blow-Off Valve to allow air to enter the system.
- 4.) Depress and Hold the "REVERSE" Pushbutton. The pump will then run in reverse, draining the fluid from the delivery line through the process and into the delivery line.
- 5.) The pump then circulates the fluid in this reverse direction into the expansion tank.
- 6.) Watch the Sight Gauge Glass as it fills up indicating how much has returned into the expansion tank.

CAUTION! EXPANSION TANK MAY NOT HAVE ADEQUATE VOLUME TO HOLD SYSTEM CAPACITY!

MODEL - K-026-D
PREVENTATIVE MAINTENANCE

Periodic inspection of the following equipment must be made to maintain optimum performance of your Sterlco Temperature Control Unit.

MOTOR:

- 1.) Clean out the motor air intake grill of dust and any oil accumulation.
- 2.) Check the bolts and nuts that hold the motor to the support.
- 3.) Make certain that the belts are in good condition and are aligned with the pump. Replace if necessary.

PUMP:

- 1.) It is a good practice to keep the pump as clean as possible. This will facilitate inspection, adjustment and repair work and help prevent omission of lubrication to fittings covered or hidden with dirt.
- 2.) Check the bolts and nuts that hold the pump to the support.
- 3.) Under normal operating conditions, the pump packing should allow a drop or two of oil per minute. The packing is of the finest type available for this service and it depends upon a small amount of oil flow for lubrication. When the new unit is first started, the packing should be checked periodically and tightened as the pump wears in. Do not over-tighten the packing gland to a point where the pump will not drip. This will shorten the life of the packing and will damage the shaft.

WARNING: DO NOT MAKE ADJUSTMENTS TO THE PACKING UNTIL AFTER IT HAS BEGUN TO DRIP. IT MAY TAKE SEVERAL DAYS FOR THE FLUID TO START DRIPPING FROM THE PACKING. ONCE THE DRIPPAGE HAS BEGUN, THE RATE NEED NOT EXCEED 1 DRIP PER MINUTE AT OPERATING TEMPERATURE. IF UNIT IS EQUIPPED WITH DRIP PUMP, INSTALL BELT AFTER DRIPPAGE HAS STARTED.

- 4.) Mechanical seal pumps should not leak. Leaking on this type of pump indicates a defective seal and the seal should be replaced.
- 5.) Grease all zerks after 500 hours of operation or after 60 days, whichever comes first. Use #2 ball bearing grease.

VENT CONNECTION:

Check to see if vent connections are open at all times.

DRAIN LINES:

Check outlet of drain line for any obstructions or back pressure.

DRIP PAN:

Clean any fluid, dust, or dirt accumulation from pan.

MODEL - K-026-D

PREVENTATIVE MAINTENANCE (cont.)

FLUID:

- 1.) Check the fluid for viscosity. Prolonged use of thickened fluid will result in malfunction of the entire system.
- 2.) Check level of fluid in the sight glass.
- 3.) If fluid level decreases, check all connections for leaks.

HEAT EXCHANGER:

- 1.) Keep exterior of the heat exchanger clear of dust or dirt.
- 2.) Check water supply for correct pressure, leaks, etc.

STRAINERS:

- 1.) Clean out the strainers twice a year, as a minimum, depending upon usage and operating conditions.

CONNECTION LINES:

- 1.) Connection lines, hoses and connectors should be inspected frequently to ensure that the original service rating has not been reduced by age, damage and/or deterioration.

TROUBLE SHOOTING

RAPID DROP IN PRESSURE:

PROBABLE CAUSE

- a.) Leaks in connecting lines
- b.) Air in circulating lines
- c.) Low fluid
- d.) Ful-Flo Valve
- e.) Pressure line

PROBABLE REMEDY

- a.) Check all connecting lines
- b.) Refer to "Start-Up" procedures
- c.) Check sight gauge glass
- d.) Broken spring, valve stuck open
- e.) Check for broken line, loose connections.

NO PRESSURE:

(See 'Rapid Drop in Pressure')

- a.) Water in circulating line

- a.) Refer to "Start-Up" procedures for Venting sequence which should be performed at a temperature of approximately 225° F.

TEMPERATURE CONTROLLER:

- a.) Heat indicator needle does not match the heat of the mold.

- a.) Release the locknut. Turn the "Offset Adjusting Nut" right or left to change the F° setting. Retighten the locknut. (See Fenwal Bulletin Fig. 2)

HEATING & COOLING:

- a.) Low or no water
- b.) Throttle valve closed
- c.) Blow-Off valve inoperable
- d.) Solenoid valve inoperable
- e.) Clogged strainer
- f.) Clogged drain line
- g.) Plugged Heat Exchanger

- a.) Check pressure of water supply line
- b.) Adjust the valve
- c.) Close valve tight
- d.) Check valve for proper operation. Watch the drain line.
- e.) Dirt from strainer entered solenoid valve
- f.) Disconnect and check the line
- g.) Examine Heat Exchanger

COOLING TOO FAST:

- a.) Throttle valve
- b.) Solenoid valve dirty

- a.) Close the valve slightly
- b.) Check valve for proper operation. Watch drain line.

COOLING TOO SLOW:

- a.) Throttle valve

- a.) Open the valves slightly, watch drain line.

Parts List #857
S.O. 84153
April 9, 1986

MODEL K026-DX

<u>PART NO.</u>	<u>DESCRIPTION</u>
715-02001	Bulb, Pilot Light
729-00063-02	Contactora, Imm. Heater
724-00292	Controller
725-00610	Fuse, Control #FNM 2.5amp @ 250V
725-00565	Fuse, Main #FRS 70 amp @ 600V
725-00633	Fuse, Motor #FRS 8 amp @ 600V
106-00094	Heat Exchanger
722-00086-17	Immersion Heater 18 KW @ 460V
037-00011	Gauge, Pressure
037-00046	Gauge, Sight Glass
720-09218	Motor - 2 HP
715-10019	Pilot Light
715-10020	Pilot Light
075-00278	Pump
075-00277	Pump
100-00013	Pulley, Pump
100-00159	Pulley, Motor
721-00104	Push Button, Forward
721-00104	Push Button, Stop
721-00104	Push Button, Rev.
714-00014	Relay, Plug-in Cont.
726-00095-02	Starter, Motor
603-00024-03	Strainer, "Y" w/screen
733-00018	Switch, Pressure
717-04002	Switch, Selector
724-00041	Thermostat
704-00089	Transformer
044-00138	Valve, Safety Relief
044-00161	Valve, Ful-Flo
732-00012	Solenoid Valve
100-00025	"V" Belt
156-00131	Door Interlock
736-00005	Alarm
701-00003	Thermocouple

STERLING, INC.
P. O. Box 23435
5200 W. Clinton Ave.
Milwaukee, WI 53223-0435

Parts List #636
S.O. 12209
December 16, 1981

MODEL K026-DX

<u>PART NO.</u>	<u>DESCRIPTION</u>
715-02001	Bulb, Pilot Light
729-00063	Contactor, Imm. Heater
724-00023	Controller
725-00629	Fuse, Control #FNM 2 amp @ 250V
725-00565	Fuse, Main #FRS 70 amp @ 600V
725-00633	Fuse, Motor #FRS 8 amp @ 600V
106-00094	Heat Exchanger
722-00086-17	Immersion Heater 18 KW @ 460V
037-00011	Gauge, Pressure
037-00046	Gauge, Sight Glass
720-09218	Motor - 2 HP
715-10019	Pilot Light
715-10020	Pilot Light
075-00278	Pump
075-00277	Pump
100-00013	Pulley, Pump
100-00159	Pulley, Motor
721-00104	Push Button, Forward
721-00104	Push Button, Stop
721-00104	Push Button, Rev.
714-00014	Relay, Plug-in Cont.
726-00095	Starter, Motor
603-00024-03	Strainer, "Y" w/screen
733-00016	Switch, Pressure
717-04002	Switch, Selector
724-00041	Thermostat
704-00027	Transformer
044-00138	Valve, Safety Relief
044-00161	Valve, Ful-Flo
732-00012	Solenoid Valve
100-00025	"Y" Belt
156-00131	Door Interlock

STERLING, INC.
P. O. Box 23435
5200 W. Clinton Ave.
Milwaukee, WI 53223-0435

Free Manuals Download Website

<http://myh66.com>

<http://usermanuals.us>

<http://www.somanuals.com>

<http://www.4manuals.cc>

<http://www.manual-lib.com>

<http://www.404manual.com>

<http://www.luxmanual.com>

<http://aubethermostatmanual.com>

Golf course search by state

<http://golfingnear.com>

Email search by domain

<http://emailbydomain.com>

Auto manuals search

<http://auto.somanuals.com>

TV manuals search

<http://tv.somanuals.com>