

INSTRUCTION MANUAL

XENON TROUPER Follow Spotlight

Type 48057

Issue 4/98



PRELIMINARY

STRONG INTERNATIONAL

a division of Ballantyne of Omaha, Inc.

4350 McKinley Street

Omaha, Nebraska 68112 USA

Tel 402/453-4444 • Fax 402/453-7238

PREFACE

THE STRONG XENON TROUPER, Type 48057, is a direct current follow spotlight complete with a xenon lamphouse, power supply, optical system, base and yoke assembly, and color boomerang. It utilizes proven design features of the Strong Xenon Super Trouper combined with advanced properties of the Strong Super Trouper II. Using a 700 watt xenon bulb as a light source, the Xenon Trouper meets or exceeds all professional requirements for short- to medium-throw follow spotlight applications.

ONLY THE SPECIAL XENON POWER SUPPLIES manufactured by Strong International can be used with the xenon spotlight. For installation and operation of the power supply, see the manual furnished separately.

THE XENON LAMPHOUSE utilizes a deep ellipse dichroic ("cold") coated metal reflector designed to operate in a fixed position with a horizontally mounted xenon bulb as the light source. The dichroic reflector coating reduces heat at the aperture and optical system.

BULB ADAPTERS, required to mount the 700 watt bulb into the lamphouse, are included in the spotlight accessory kit. Two anode adapters are supplied; the 65259 adapter, measuring 2-5/8 inches in length, is used with the Hanovia XH0700HS bulb, and the shorter 65199 adapter is used with the OSRAM XBO700W/HS OFR bulb.

ADJUSTMENT CONTROL for positioning the xenon bulb is located at the rear of the lamphouse. The adjustments are for the horizontal and vertical positioning, and focus control, of the bulb.

THE LAMPHOUSE INSTRUMENT PANEL is equipped with an ammeter and running time meter. The ammeter indicates the operating current of the lamp, and the running time meter records the number of hours the lamp has operated.

THE BULB is ignited and extinguished by use of the LAMP switch mounted on the instrument panel. A DC Pulse Igniter Assembly requires no AC control circuit; it operates from DC open circuit voltage normally generated by the xenon power supply. Remote ignition switching is accommodated by wiring a dry contact across wires 3 & 6. See the Interconnection Wiring Diagram.

THE LAMP BLOWER, internally wired in the lamp, operates on 115 V.AC and is required to keep the seals on the bulb at a safe operating temperature. This blower will operate continuously until power is turned off at the main line switch to the xenon power supply.

THE LAMPHOUSE is supplied with a 13 foot cable containing the two DC leads, the ground lead, and all AC control leads. The cable terminates in a multiple pin MS connector to mate to the receptacle on the power supply.

WHEN TRANSPORTING the spotlight, it is recommended that the xenon bulb be removed and placed in its original shipping carton with the cover on the bulb to insure against breakage.

LAMPHOUSE - POWER SUPPLY Interconnection Diagram

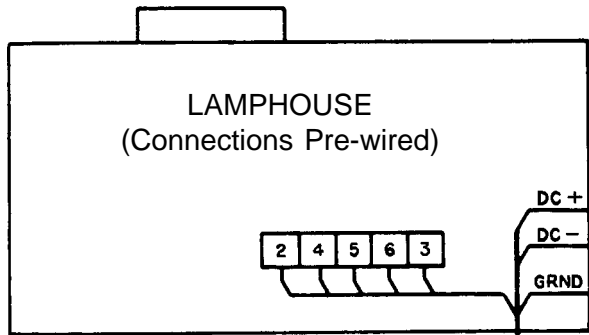

MS CONNECTOR

Pin	Wire No.
A	DC-
B	DC+
C	2
D	3
E	4
F	5
G	6
I	7
J	8
M	Grnd

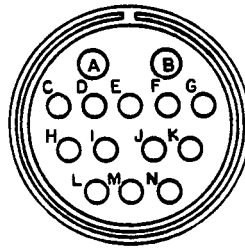

Lamphouse
Cable Assembly

Conduit

Remote - Auto
Sustained 5 Amp.
Dry Contact
(by Installer)

SYSTEM MUST BE GROUNDED
All wiring must conform to local
codes; shield lamphouse cable in
conduit if required.

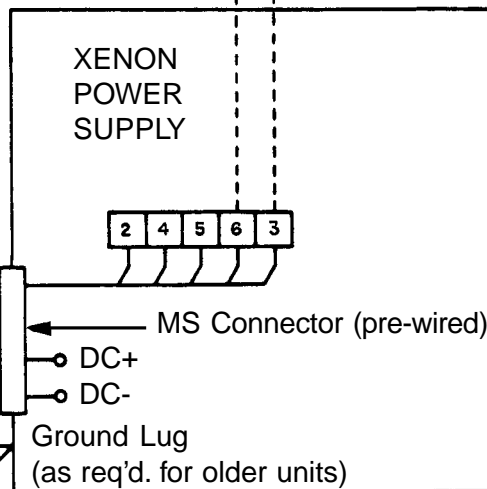

XTR/002

INSTALLATION & SET-UP

THE XENON TROUPER is shipped in sections which must be assembled. The Folding Base Stand Assembly 65838 is shipped collapsed, and requires only unfolding and securing the (4) base legs using the T-bolts supplied.

WHEN INSTALLED in a permanent location, the leveling feet must be removed, and the clearance holes in the base leg brackets used for hardware (user supplied) to bolt the base to the floor or platform. If it is desired to have the unit portable, when operating, the leveling feet *must* be adjusted down until the weight of the spotlight has been shifted from the casters to the leveling feet.

THE INNER TUBE and support yoke has three holes to permit adjusting the height of the spotlight. The three holes are on four inch centers and will allow an optical height of approximately 53 inches, 57 inches, and 61 inches above floor level to the optical center of the lamphouse and lens system. The leveling feet may be adjusted through an additional two inch range. Insert the height location pin through the hole in the outer tube and one of the holes in the inner tube.

THE HORIZONTAL SWING and vertical tilt locking knobs are on the right hand (operating) side of the yoke assembly. Tighten both of these locking devices securely before attempting to place the lamphouse and lens system on the support yoke.

PLACE THE LAMPHOUSE and lens system on the yoke assembly, with the spot size control handle to the right hand (operating) side, the same as the locking controls on the yoke. Line up the four mounting holes in the bottom of the base rail with the four mating holes in the support yoke and secure with the four 5/16-18 wing screws.

ATTACH THE COLOR BOOMERANG to the front of the optical system cover by inserting the hinge pin through the hinge on the boomerang and optical system. Fasten the boomerang yoke to the slotted angle bracket on the underside of the optical system pan. Adjust and securely tighten the wing nut and lock nuts to hold the boomerang parallel with the front of the optical system housing.

ATTACH THE LAMPHOUSE CABLE CONNECTOR to the receptacle on the power supply. Align the pins before tightening the locking ring. Do not energize the xenon power supply before first installing the xenon bulb into the lamphouse.

EARLIER MODELS of Strong xenon spotlights included a heavy-gauge green ground wire in the lamphouse cable assembly. This ground wire was attached to a ground stud connected to the power supply cabinet. Current models of Strong power supplies include a 1/4-20 stud in the cabinet adjacent to the MS connector to allow ground termination of older spotlights.

SAFETY PROCEDURES



READ CAREFULLY BEFORE INSTALLING XENON BULB



THE XENON BULB is highly pressurized. When ignited, the normal operating temperature of the bulb increases the pressure to a level at which the bulb may explode if not handled in strict accordance to the manufacturer's operating instructions.

THE BULB is stable at room temperature, but may still explode if dropped or otherwise mishandled. Breakage resulting from transport and handling is *not* covered by the bulb manufacturer's warranty, and it is strongly recommended to disassemble the xenon bulb when transporting the spotlight.

REFER bulb replacement and service to QUALIFIED PERSONNEL with adequate protective clothing (face shield, clean cotton gloves, welder's jacket). For routine lamphouse service, observe the following rules:

1. Allow the bulb to cool to room temperature before opening the lamphouse. Put on protective clothing described above.
2. De-energize the xenon power supply at the AC source before opening the lamphouse compartment.
3. When possible, encase the bulb in its protective cover when cleaning or servicing the lamphouse interior. The bulb, when outside the lamphouse, must be encased in the cover.
4. Clean the bulb after it has cooled to room temperature. Do not touch the quartz envelope of the bulb; fingerprints will burn in and create hot spots which may shorten bulb life. If fingermarks are made, they should be carefully removed with methyl alcohol and cotton prior to bulb operation.
5. Never view an ignited bulb directly. **BLINDNESS OR PERMANENT EYE DAMAGE MAY BE INCURRED.**
6. Use only xenon bulbs designated as OZONE FREE. When possible, vent the lamphouse exhaust to outside atmosphere.
7. Maintain the lamphouse blower in good operating condition. Keep the blower inlet clean for unrestricted air flow.
8. To insure maximum bulb life, operate the lamphouse blower and the exhaust system for **at least ten** minutes after extinguishing the bulb.
9. If returning a bulb for warranty adjustment, pack it in its original shipping container. Complete and return all required warranty information.

10. Dispose of expired bulbs that are beyond warranty in the following manner: Wrap the bulb tightly in several layers of canvas or heavy cloth. Place it on a hard surface and shatter the envelope with a sharp hammer blow. DO NOT place an unshattered bulb in an ordinary refuse container.
11. DO NOT PERMIT UNAUTHORIZED PERSONNEL TO PERFORM OR ATTEMPT ANY PHASE OF XENON BULB HANDLING OR SERVICE.

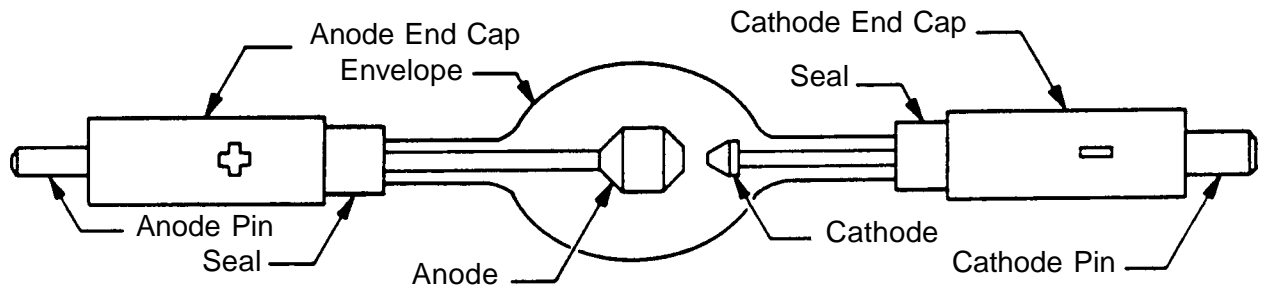

700 WATT XENON BULB INSTALLATION

Type 48057 Trouper

CAUTION: OBSERVE ALL SAFETY PROCEDURES. Put on the protective face mask. Wear clean cotton gloves to prevent marking the quartz envelope of the bulb with fingerprints.

REMOVE THE TOP COVER of the lamphouse by removing the four Holt head (tamperproof) screws with the special screwdriver provided. Loosen the two knurled-head thumb screws (65152) on the front bulb support yoke and pivot the retaining plate (65151) aside. Slide the 65131 clamp on the end of the igniter lead over the brass socket of the rear bulb support collet (65844).

ASSEMBLE THE ADAPTERS to the 700 watt bulb prior to inserting the bulb into the lamphouse. Be very careful *not* to apply any strain on the quartz envelope when installing adapters. Screw the cathode adapter (65198) onto the threaded negative stud so it seats firmly against the shoulder of the (-) end cap. Slip the 65259 anode adapter over the positive pin up to the shoulder of the (+) end cap. Tighten the set screw (00720) securely to insure a good electrical connection.

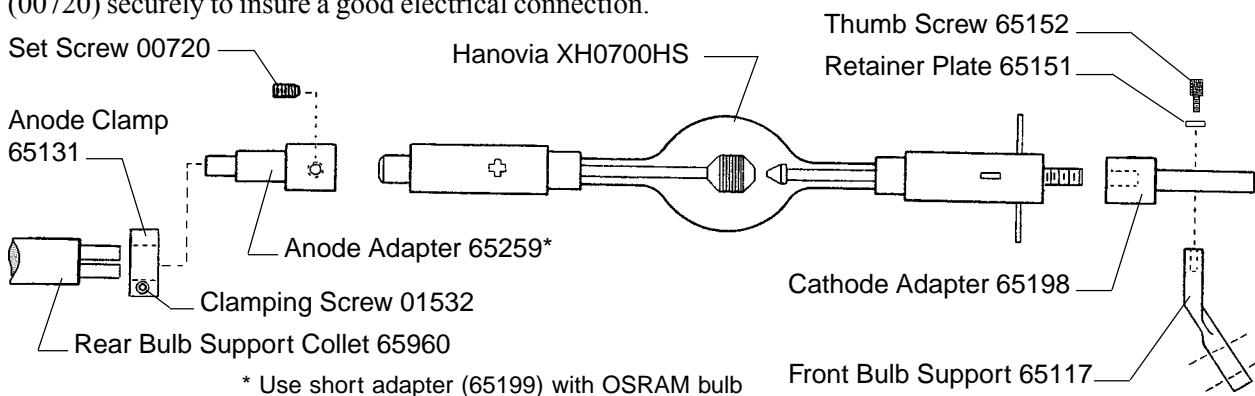

REMOVE THE PLASTIC PROTECTIVE COVER from the xenon bulb only if necessary. Insert the bulb through the top of the lamphouse, between the reflector support and the front casting. Pass the anode (+) end of the bulb through the hole in the reflector, taking care *not* to touch the surface of the reflector.

INSERT THE ANODE ADAPTER STEM into the rear support collet. The stem must be inserted as far as possible to permit full focus travel of the bulb. Place the cathode adapter into the 65117 front bulb support, pivot the retaining plate to its closed position, and tighten the (2) thumb screws. Tighten the socket head clamping screw in the anode contact securely to insure a good electrical contact.

INSTALL THE CATHODE LEAD CONTACT over the end of the cathode adapter up to the shoulder of the contact and tighten the clamping screw securely. Lay the lead in front of the air duct to minimize the shadow.

A GLASS STRIP HEAT FILTER is supplied to reduce the thermal energy at the optical system and color gels. Insert the heat filter in the bracket provided on the inside of the lamphouse at the front opening. Place the filter in position *with the coated surface facing the bulb*. The coated surface is indicated by a small XX or other marking. This filter is a narrow strip that covers only the center portion of the beam. To prevent damage to optical system components, **do not** operate the spotlight with the filter removed or reversed.

REMOVE THE PLASTIC COVER from the xenon bulb. Store the protective cover and the original bulb packing in a secure location. The spare anode adapter (65199) is for use with an OSRAM 700 watt bulb (XBO700W/HS OFR) should such a bulb be used as a replacement.

SECURE THE LAMPHOUSE COVER with the (4) tamperproof screws using the special screwdriver provided. The cover must be securely in position to actuate the interlock switch and permit lamp ignition.

IT IS RECOMMENDED to establish a routine for periodically checking all electrical connections for tightness, particularly those at the bulb. A loose connection in the DC circuit will cause failure of the contacts and leads, and may damage the bulb.

OPERATION

PLACE THE MODE SWITCH (on units so equipped) in the "MAN." position and energize the xenon power supply. The lamphouse blower will start and actuate the blower interlock switch to permit bulb ignition. This lamp blower will operate continuously until the xenon power supply is de-energized.

PLACE THE LAMP SWITCH in the ON position and the xenon bulb will ignite. Allow a few minutes for the current to stabilize, and read the lamphouse ammeter. The 700 watt xenon bulb must be operated within the current range specified by the bulb manufacturer, normally 36 amperes nominal; maximum current 40 amperes. Refer to the manufacturer's documents shipped with the bulb for the exact figures.

ADJUST THE POWER SUPPLY as instructed in the power supply manual for the correct operating current. New 700 watt bulbs are normally first operated at their *nominal* current level (36 A.). The current setting must be increased in time to compensate for bulb aging, but **do not**, at any time, exceed the maximum current rating (40 A.).

REMOVE THE REAR COVER PANEL (two pull type knobs) located below the instrument panel. This will expose the bulb position adjustment controls.

BULB ADJUSTMENT CONTROLS

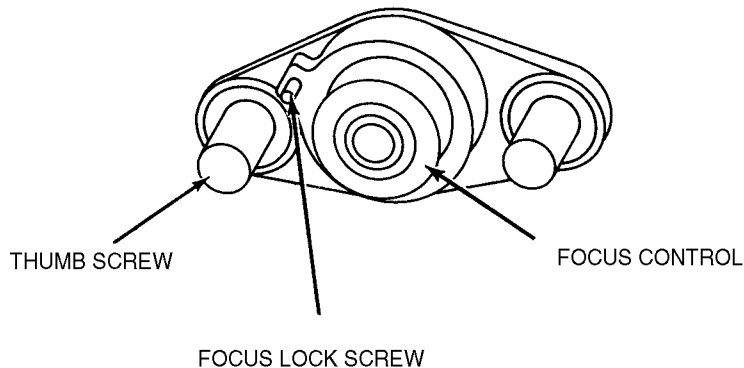

THE CENTER SECTION of the control is a threaded member that focuses the bulb in relation to the reflector. Turning this adjustment moves the bulb on the horizontal plane, into or out of the reflector. Rotating this section clockwise moves the bulb away from the reflector. The small knurled screw to the left of this section can be tightened to lock the focusing mechanism in place after the bulb alignment procedure has been completed.

THE THUMB SCREWS to the left and right of the focusing control lock the horizontal and vertical position of the bulb. These thumb screws are spring-loaded to apply a degree of friction against the lamphouse back casting.

TWO METHODS are recommended to align the bulb in order to project the best light to the stage:

MOVE THE SPOT SIZE CONTROL HANDLE on the large lens carriage to the forwardmost position to project the smallest spot possible with the iris, choppers, and dimming controls in their full open positions. Project the spot to a wall or similar flat perpendicular surface opposite the spotlight.

TURN THE CENTER FOCUS CONTROL counterclockwise until a small black spot is projected on the wall. It may be well to run this adjustment both directions to permit positive identification of the dark spot.

LOOSEN THE TWO THUMB SCREWS to the left and right of the focus control just enough to permit manual movement of complete control assembly. Move the control assembly around the two thumb screws and observe the smooth dark shadow of the bulb electrode inside the shaded circle of the reflector center opening. The shadow of the electrode must be centered in the projected opening of the reflector.

MOVE THE CONTROL ASSEMBLY around the thumb screws until the dark electrode shadow is as round as possible to project. It may be necessary to again rotate the focus control to define the electrode shadow.

AFTER THE ELECTRODE SHADOW is as even around the outside as possible, tighten the two thumb screws to lock this adjustment in place, and rotate the focus control to obtain the brightest light with the best light distribution. Turn the spot focus control knob, located on the front of the lens mechanism, to sharpen the edge of the spot.

THE SECOND METHOD of aligning the xenon bulb is to project the spot to the stage, and using the bulb adjustment controls, obtain a "hot spot" in the projected spot. Center this "hot spot" in the projected spot by moving the entire control section around the two thumb screws. Once the "hot spot" is centered in the projected spot, lock the adjustment control in position with the two thumb screws and rotate the focus control to obtain a spot with an even distribution of light. Turn the spot focus control knob at the front of the lens mechanism to sharpen the edge of the spot.

THIS ADJUSTMENT should not be disturbed until the xenon bulb is rotated or replaced. At this time it will be necessary to repeat the alignment procedure.

REPLACE THE REAR COVER PANEL over the bulb adjustment control mechanism. Secure using the plastic fasteners.

BECAUSE OF MANUFACTURING TOLERANCES and normal bulb aging, it may be necessary to operate one lamp at slightly higher or lower current than others to obtain equal light balance between two or more spotlights. These adjustments are made at the xenon power supply.

TO EXTINGUISH THE ARC, place the LAMP switch in the OFF position. The blower in the lamphouse will continue running until the xenon power supply is de-energized. Allow the blower to operate and cool the bulb for *at least* five minutes after extinguishing.

HANDLING THE SPOTLIGHT

GENERALLY THE BEST POSITION for the operator to stand is near the center of the spotlight, on the right hand side, although the angle of tilt and the size of the porthole may alter the position for the most convenient operation.

EACH OPERATOR will, after a few minutes of operation, generally develop his own system and position for operating the unit.

THE HORIZONTAL SWING LOCK LEVER and vertical tilt lock lever located on the base assembly can be set to give the desired amount of friction on the spotlight swing to suit the individual operator.

THE LENS CARRIAGE FRICTION BRAKE is a nylon drag screw located on the outrider of the large lens carriage, and is preset at the factory for most satisfactory operation. Individual requirements may vary, and the brake can be adjusted to best suit the operator or allow for a severe "down" angle. Remove the color boomerang and lens mechanism housing, loosen the nylon lock nut and adjust the screw on the friction brake to apply the desired tension. Tighten the lock nut and replace the housing and boomerang.

REMOTE/AUTO OPERATION

TO IGNITE THE SPOTLIGHT from a remote location or an automation controller, the lamphouse must be equipped with the MODE (Auto-Man.) switch. With the MODE switch in the "AUTO" position, and the LAMP switch "ON", the lamphouse will ignite by means of a dry contact across terminals 3 and 6 at the lamphouse or power supply (See Lamphouse-Power Supply Interconnection Diagram). This type of installation is intended for use only if the spotlight is locked down as a fixed spot without an operator at the unit.

EXHAUST SYSTEM INSTALLATION

IF THE SPOTLIGHT is installed in a closed booth, it is recommended to vent the lamphouse exhaust to outside atmosphere to remove the heat from the booth.

THE EXHAUST STACK of the lamphouse is designed to fit a six inch diameter duct. The exhaust system must be designed and installed in a way to eliminate any possibility of a down draft or of rain dripping into the lamphouse. The exhaust fan must be capable of removing 750 lineal feet (150 cfm) of air per minute at each lamphouse.

TO PERMIT MOVEMENT of the follow spotlight, install a section six inch diameter flexible tubing between the lamphouse exhaust stack and the projection booth exhaust system. The two holes in the stack exposed by removing the vent cap can be used to secure the tubing.

IF THE INSTALLATION is to be made in a location where it is not possible to install an exhaust system, leave the vent cap mounted to the exhaust stack.

THE RADIATION from some xenon bulbs can convert the oxygen in the surrounding air to ozone. In large quantities, ozone can endanger health, but it spontaneously changes back into oxygen in a very short time, especially if it mixes with a large volume of air (as in an auditorium, arena, or outdoors). Most currently manufactured xenon bulbs are classified as *ozone free* and do not release ozone.

OPERATION OF OPTICAL SYSTEM

THE IRIS CONTROL is the front lever which projects through the top of the optical system housing. When this lever is to the left (as viewed from the rear of the unit), the largest aperture is provided. Smaller apertures are obtained as the lever is moved to the right.

THE SPOT SIZE CONTROL HANDLE is located on the right hand side of the optical system just above the base rail. A variation of spot sizes from full flood to small spot can be obtained by moving the spot size control handle from one extreme to the other. Beam intensity is increased by this optical system when reducing from flood to spot, and maximum intensity is reached when the spot size control handle is in the extreme forward position.

THE MAXIMUM FLOOD SPOT is obtained with the iris control lever to the left (away from operating side) for the largest aperture and with the spot size control handle moved as far to the rear as possible.

SMALLER SIZED SPOTS are projected as the spot size control handle is moved forward. Most of the spot sizes needed will be produced with the iris in its maximum open position.

FOR A "HEAD SPOT," or any spot smaller than can be obtained with the spot size control handle in its extreme forward position, shift the iris control lever to the right (toward operating side) for a smaller aperture. The iris control lever should always be returned to its extreme left position before the spot size control handle is again moved to obtain larger spots.

THE MASKING SHUTTER (chopper) lever is the middle lever projecting through the top of the optical system housing. The masking shutter blades are operated by this lever to shape the projected spot to a rectangle, strip spot, or dousing.

THE DISENGAGED POSITION of the masking shutter lever is to the extreme right (toward operating side) and varying degrees of masking to complete cutoff are obtained by moving the lever to the left (away from operating side).

THE ANGLE of the masking shutter blades can be adjusted to compensate for the horizontal projection angle. Remove the color boomerang and optical system housing, and loosen the screws holding each of the masking shutter blades enough to allow adjustments. Ignite the bulb and adjust the angle of the *bottom* blade by tapping with a screwdriver so its projected edge lies parallel to the footlights. Tighten the screw. Operate the masking shutter lever to close the blades. Adjust the upper blade to close in line with the bottom blade and tighten the screw.

THE FADEOUT MECHANISM AND DOUSER CONTROL is the rear lever projecting through the top of the optical system cover. This lever controls the intensity of light from complete fadeout when the lever is to the left, to full intensity when the lever is to the right.

THE SPOT FOCUSING CONTROL KNOB is located on the operating side of the optical system at the forward end above the base rail. This control is used to adjust the optical system for the length of throw. When making an adjustment, rotate the spot focusing control knob until the sharpest edge is obtained on the projected spot.

OPERATION OF COLOR BOOMERANG

THE COLOR BOOMERANG is equipped with six color holders and an ultraviolet filter. Additional filter holders can be supplied by an authorized Strong International Dealer.

TO OPERATE INDIVIDUAL COLOR FILTERS, lower the desired filter selector lever. A rocker catch located in the color disc housing holds the filter in position.

TO RELEASE A COLOR, push the filter release lever or engage another color, thus releasing the previous color automatically.

TO REPLACE A FILTER HOLDER, open the hinged top of the color disc housing and lift out the desired filter holder.

HIGH TEMPERATURE FILTERS (RoscoLux® or equivalent) cut to nine inch diameter are required, and are secured in the filter holders with paper fasteners.

NOTE: WHEN PLACING COLOR FILTERS in the boomerang, the *less* dense colors (pink, amber) should be placed in the holders toward the **rear** of the boomerang (toward arc), and those of *greater* density (red, green) should be placed in the holders toward the **front** of the boomerang (away from the arc).

COLOR TEMPERATURE REDUCTION FILTERS, required for use with television and videotape, are available from theatrical supply dealers.

MAINTENANCE

THE STRONG XENON TROUPER SPOTLIGHT requires very little maintenance to keep it in good working order.

THE REFLECTOR should be cleaned periodically with a soft, clean, lint-free cloth to remove dust from the reflecting surface. If excessively soiled, the reflector may be cleaned with Windex® or an equivalent glass cleaner. DO NOT use abrasive cleaners of any kind. Clean the heat filter glass; replace with the coated surface toward the lamphouse.

CHECK ALL ELECTRICAL CONNECTIONS for tightness on a regular basis. Loose connections, particularly in the DC circuit, may cause premature bulb failure and damage lamphouse components.

THE XENON BULB should be checked occasionally for the presence of dust or foreign materials. If necessary, clean the quartz envelope of the bulb with alcohol, and wipe dry with a clean, lint-free cloth. Observe all safety procedures when working with the exposed bulb.

THE INSIDE OF THE LAMPHOUSE and the blower should be cleaned periodically, depending on the dust conditions at each installation. Keep the blower inlet grille clean to permit free air flow. The blower is permanently lubricated and requires no oil.

THE LENS SYSTEM should be kept clean to prevent any light reduction in the projected spot. Tighten the horizontal swing and vertical tilt locking clamps. Remove the boomerang and the optical system cover to reach and clean the back surface of the large lens. Remove the cover casting over the fadeout, chopper, and iris controls to remove the small projection lens which is held in place with a large spring-type retainer ring at the front of the lens barrel.

CLEAN THE PROJECTION LENS and large lens with with any cleaner approved for use on coated projection lenses. Replace the projection lens with the end with the FL marking ring toward the iris; secure with the retainer ring.

BEFORE TRANSPORTING the spotlight, remove the xenon bulb from the lamphouse. Place the bulb in its plastic cover and original shipping container.

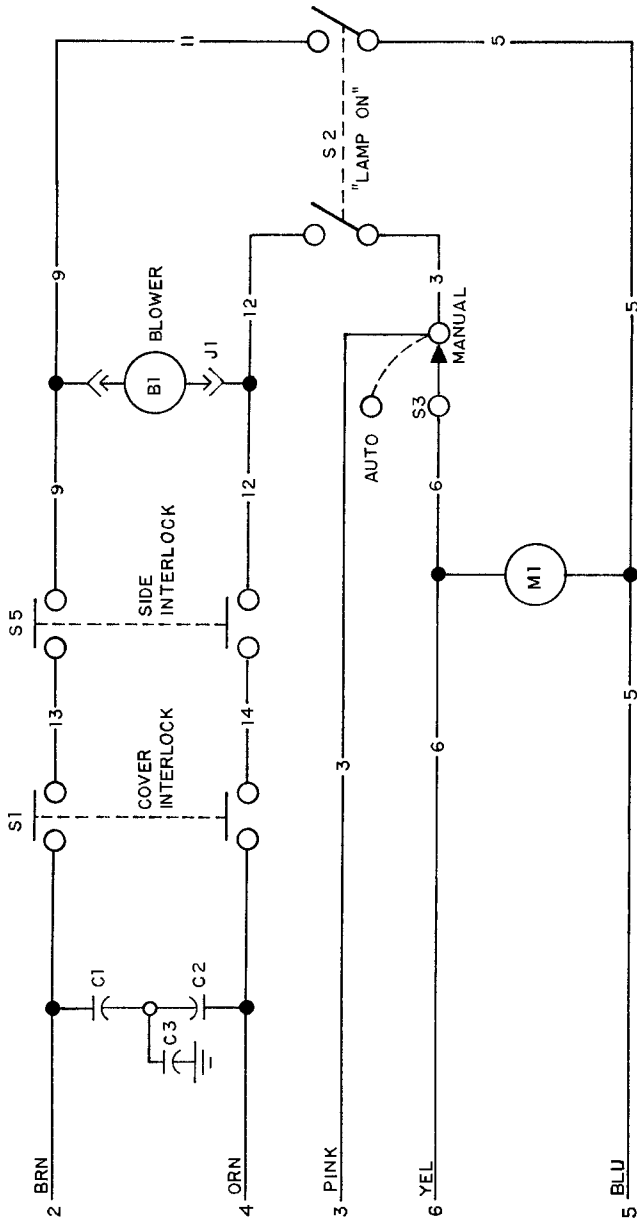

MS CONNECTOR

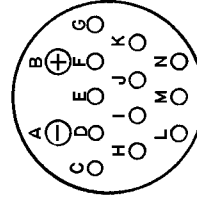

- A = BLK DC-
 - B = RED DC+
 - C = BRN #2
 - D = PINK #3
 - E = ORN #4
 - F = BLU #5
 - G = YEL #6
 - H = BLK #8
 - I = GRN #7
 - J = BLK #8
 - M = GRN Gnd
- Wires 7 & 8 not connected to Trouper

LAMPHOUSE WIRING DIAGRAM
Xenon Trouper

PARTS LIST
Wiring Diagram

Ref, Desig.	Part No.	Description
B1	62-98002	Blower, 115 V.AC, 50/60 Hz.
C1,2	76132	Capacitor, .005 μ f, 600 WVDC
C3	76133	Capacitor, .01 μ f, 400 WVDC
C4A,B	80177	Capacitor, 1.0+1.0 μ f, 600 WVDC
C5	81947	Capacitor, .01 μ f, 600 WVDC
DS1	-	Xenon Bulb, 700 Watt
M1	65891	Elapsed Time Meter, 60 Hz.
-	39195	Elapsed Time Meter, 50 Hz. (Export)
M2	65142	Ammeter, 0-150 A.
R1	82167	Shunt, 150 A. 50 mV.
S1	80168	Top Cover Interlock Switch
S2	81275	LAMP Switch, ON-OFF
S3	81276	MODE Switch, AUTO-MAN.
S5	80168	Side Cover Interlock Switch
J1	37990	Fan Cord & Plug Assembly
	65503	DC Pulse Igniter Assembly
	65935	Lamphouse/Power Supply Cable Assembly
	88318	MS Connector (incl. with 65935)

TROUBLE CHART

NORMAL OPERATION

WHEN THE SWITCH in the main AC supply line to the xenon power supply is in the ON position, and the 30 A. circuit breaker on the switching power supply is ON, the POWER light on the xenon power supply will glow. The lamphouse blower will start. The blower in the power supply, if a older Strong high reactance type (61000, 61001) or current production switching type, will operate.

IF THE LAMPHOUSE TOP COVER and access panel are correctly installed, the top and side panel interlock switches will close. At this time, the control circuit to the LAMP switch will be completed.

THE MODE SWITCH, located on the lamphouse instrument panel, should be in the "MAN." (manual) position. This is the normal setting for spotlight operation, as it allows direct ignition control by the operator.

WHEN THE "LAMP" SWITCH is placed in the ON position, the AC control circuit in the lamphouse will energize the power supply contactor circuit and provide DC current to the igniter and bulb. The high DC open circuit voltage generated upon start-up of the power supply will actuate the DC Pulse Igniter.

THERE WILL BE a distinctly audible high voltage arc ping at the igniter arc gap and across the bulb electrodes. The bulb should ignite immediately after one or two of these high voltage pulses, and the lamp current will adjust to the output setting of the xenon power supply. Multiple ignition pulses prior to bulb ignition normally indicate a low DC output setting. See xenon power supply manual. A "warm" or aged xenon bulb might also require multiple strikes.

TROUBLE SHOOTING

IF THE XENON BULB does not ignite, observe the following operational sequences for assistance in locating and isolating the trouble area.

WHEN THE FAN(S) and the indicator light on the power supply are on, the AC circuit in the power supply is trouble free up to the terminal block in the power supply.

AT THIS TIME, the lamphouse blower should operate. If this does not occur, the trouble is in the cover interlock switch, the access panel interlock switch, the blower motor, a loose connection, or a broken #2 or #4 lead. Check at this time for **115 V.AC Control Voltage** at the cover interlock switch (wires 2 & 4), the side access panel (wires 13 & 14), and the blower terminals (9 & 12). The cover interlock switch must be manually actuated to energize the blower. *Observe caution when taking voltage readings in a power ON condition.*

THE VANE on the air flow switch should actuate. With the MODE switch in the "MAN." position and the LAMP switch in the "ON" position, the running time meter should start and indicate elapsed time. If this meter does not operate, check for continuity at the MODE and LAMP switches. A defective running time meter will **not** prevent bulb ignition.

WITH THE "LAMP" SWITCH in the "ON" position, a distinct high voltage arc ping should be heard at the spark gap in the igniter, and the flash of the xenon bulb should be visible through the ammeter as a high RF voltage pulse is applied across the bulb electrodes.

IF THE HIGH VOLTAGE PING or the flash at the ammeter is not apparent, check the "**No Load**" DC Voltage between the lamphouse and power supply. Check the DC voltage across terminals #10 (-) and #15 (+). A reading of 85-150 V.DC should be measured if using a high reactance power supply; 140-170 V.DC if using a switching type. If this voltage is not indicated, the problem is in the leads between the lamphouse and power supply, or in the power supply boost circuit. See the trouble shooting section of the power supply manual for additional instructions.

THE SWITCHING-TYPE xenon power supply normally furnished with the spotlight system contains thermal overload switches and circuits to protect the power supply from high or low AC input voltage. A lack of open circuit voltage, or interruptions in sustaining DC current, may be traced to these circuits.

IF THE HIGH VOLTAGE ARC is audible at the lamphouse and the bulb does *not* flash, check for a lamphouse DC lead arcing to ground. If no ground fault is detected, replace the bulb and attempt ignition with the new bulb.

IF THE HIGH VOLTAGE ARC is audible at the lamphouse, the flash of the bulb is visible in the ammeter, but ignition of the bulb is not sustained, the problem area is in the power supply. See the trouble shooting section of the power supply manual for additional instructions.

IF THE HIGH VOLTAGE ARC is *not* audible or the flash of the bulb visible, the problem is in the igniter assembly.

EXCHANGE of components (i.e. igniters, power supplies) between similar Strong Xenon Troupers to aid in diagnosis of a problem is encouraged. This will not lead to equipment damage, and will not void equipment warranty.

XENON TROUPER TROUBLESHOOTING

Bulb fails to ignite.

1. MODE switch S3 set to "AUTO." Place in "MAN." position when not employing automated or remote lamphouse operation.
2. AC power not on to lamphouse. Turn switching power supply 30 A. circuit breaker ON. If 115 V.AC not read at 2 & 4, see power supply manual.
3. Top cover or side access panel interlock switch (S1, S5) open. Close and secure lamphouse top cover. Tighten all four mounting screws; check switch actuating screw. Tighten side access panel screws.
4. Faulty interlock switch(s). Check for 115 V.AC at 9 & 12; replace switch(s) if defective.
5. Faulty S2 "ON-OFF" switch. Check for voltage at 3 & 5; check for loose terminals or wiring. Replace if defective.

Bulb fails to ignite; ping audible, bulb flash visible.

1. Inadequate DC output from xenon power supply. Set power supply output to correct range required for bulb wattage (65 A. for 1.6 kW, 75 A. for 2 kW).
2. If bulb flash is visible but faint, check for defective glass capacitor 65216 in igniter (capacitor body cracked or leaking oil). Replace if defective.
3. Faulty or expired xenon bulb. Replace as required.

Bulb fails to ignite; ping audible, no bulb flash.

1. Faulty xenon bulb. Check for cracked electrodes or darkened envelope. Replace if defective.
2. Ignition pulse shorting to ground. Inspect DC leads for burned insulation; dress leads away from grounded metal components.

No high voltage ping audible; MODE switch in "MAN." and LAMP switch in "ON."

1. Loss of AC control voltage. Check xenon power supply for tripped circuit breaker or open thermal switch. See power supply manual.
2. Little or no DC "No Load" voltage. Measure DC "No Load" voltage at 10 & 15. See power supply manual.
3. Open fuse F1 (600 V.) on switching power supply. SEE POWER SUPPLY MANUAL. Allow (20) minutes for capacitor discharge before replacing.
4. Faulty igniter. Check for adequate DC "No Load" at 10 & 15. If present, and igniter does not fire, replace igniter.

Bulb goes out during operation.

1. Xenon power supply overheated; thermal switch open. Check power supply blower(s), air inlets and outlets unobstructed. See power supply manual.

Bulb goes out during operation (continued)

2. Xenon bulb depressurizing. Check for envelope discoloration; replace if defective.
3. Power supply brown-out protection actuated by voltage drop. See power supply manual.
4. Phase loss detected by power supply (3 phase units only). See power supply manual.

Power supply does not energize when actuated.

1. S1 or S5 cover interlock switch, S4 air vane switch, S2 power switch, S3 MODE switch. Check for 115 V.AC at each station; replace defective component.

SEE POWER SUPPLY TROUBLESHOOTING UNDER SAME HEADING.

Noise in theatre sound as bulb ignites.

1. Faulty RF suppression capacitor(s). Remove and test C1, C2, C3, C4A or C4B. Replace if defective.
2. Lamphouse, power supply, or sound system not properly grounded. Connect to adequate earth ground.
3. Leads between lamphouse and automation contact not shielded. Shield leads in conduit.

Excessive light flicker.

1. Faulty or aged bulb. Check for cracked or sagging electrodes; replace if defective.
2. Excessive ripple in DC output. See power supply manual.
3. Arc stabilization magnet reversed. NORTH pole should point toward operator side. Check with compass if required.

Reduced light output.

1. Normal bulb aging. Increase output current. DO NOT EXCEED MAXIMUM CURRENT SPECIFIED BY BULB MANUFACTURER.
2. Soiled reflector. Clean using commercial glass cleaner. USE NO ABRASIVES.
3. Soiled heat filter, projection lens or large lens. Clean as required.

Extremely long duration between ignition pulses.

1. Low DC "No Load" from xenon power supply. Check "No Load" voltage; see power supply manual.
2. Defective spark gap. A "Ping" sound is normal; excessive "Hissing" is abnormal. Replace if defective.
3. Low AC voltage to lamphouse. Check for 115 V.AC at 2 & 4; if below 95 volts, check stepdown or isolation transformer in xenon power supply. See power supply manual.

Color gels burning or fading prematurely.

1. Bulb focused to “hot spot.” Refocus bulb to flat field with iris fully open and spot size control handle (“trombone”) fully forward.
2. Heat filter glass reversed or peeled. Check for coated surface *toward* bulb; replace if coating peeled.
3. Reflector coating peeled. Replace if defective.

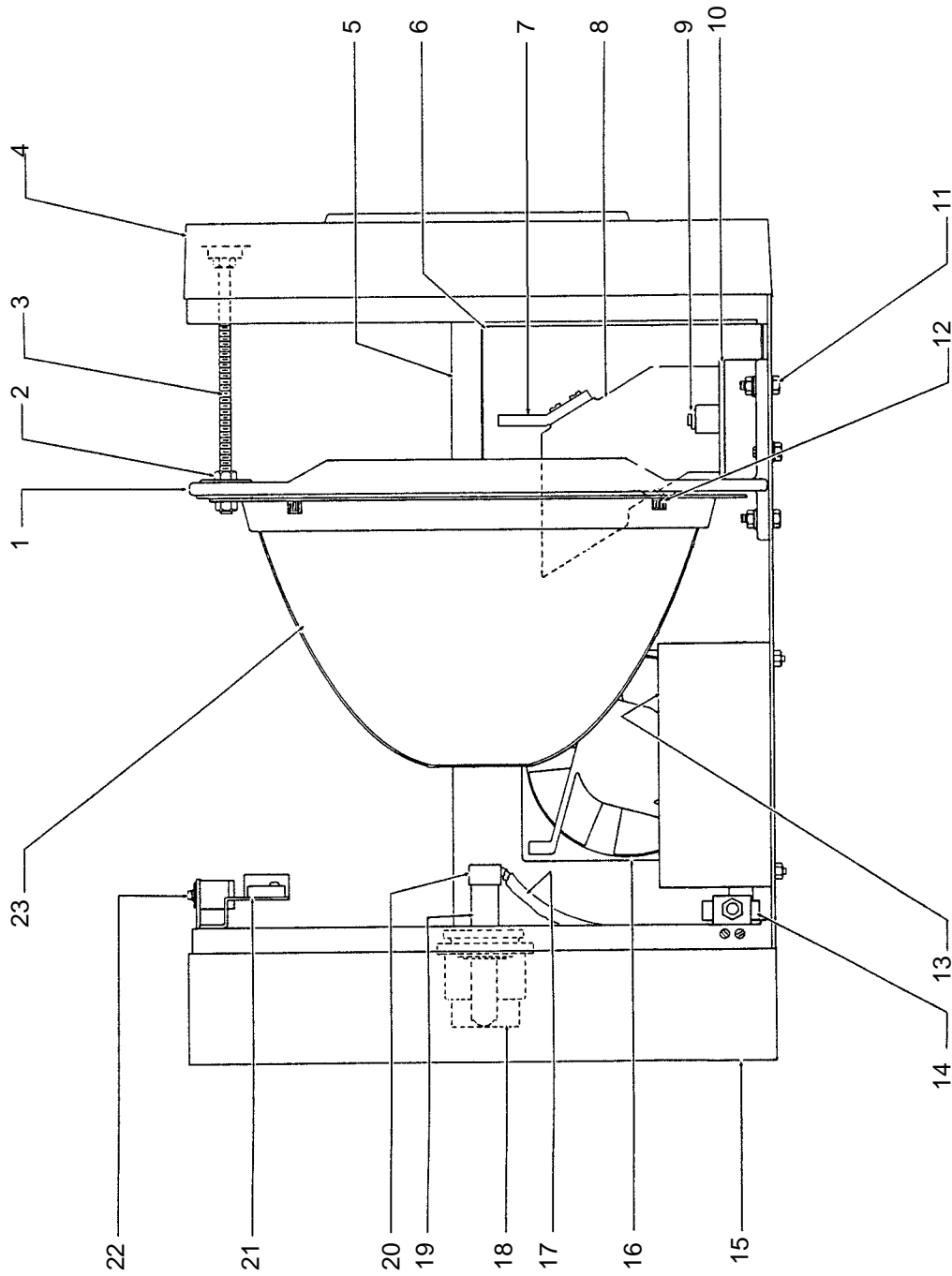

FIGURE 1

PARTS LIST

Figure 1

Item	Part No.	Description
1	65114	Reflector Bulkhead Casting
2	00805	Tie Rod Lock Nut, 1/4-20 Hex
3	65164	Tie Rod, Bulkhead to Front Casting
4	65111	Lamphouse Front Casting
5	65865	Lamphouse Base Pan & Lower Side
6	65155	Inner Heat Shield, Left
-	65156	Inner Heat Shield, Right (not shown)
7	65117	Front Bulb Support Yoke
-	65151	Retainer Plate
-	65152A	Thumb Screw, Retainer Plate (2 req'd.)
-	01567	Mounting Screw, 10-24 x 1/2" Bind Head
8	65115	Air Duct Casting
9	00262	Screw, 8-32 x 1" Fillister Head
-	65171	Insulator Bushing
10	65175	Insulator Plate
11	41-51122	Screw, 1/4-20 x 3/4" Hex Head
-	00876	Lockwasher, 1/4" Split Ring
-	00805	Hexnut, 1/4-20
12	01432	Screw, 1/4-20 x 1/2" Socket Head
13	65503	DC Pulse Igniter Assembly
14	80168	Side Cover Interlock Switch (S5)
-	72178	Switch Mounting Bracket
15	65112	Lamphouse Back Casting
16	61-98002	Blower (B1), 115 V.AC, 50/60 Hz.
17	65966	Igniter Lead & Clamp Assembly
18	65827	Bulb Positioning Assembly (less Collet)
19	65960	Rear Support Collet
-	21-48027	Collet Retaining Ring
20	65131	Contact Clamp (incl. with Item 17)
21	65134	Barrier Strip, (10) Terminal
-	00182	Screw, 6-32 x 7/16" Fillister Head
-	65160	Barrier Strip Mounting Bracket
-	00255	Screw, 8-32 x 5/16" Fillister Head
22	80168	Top Cover Interlock Switch (S1)
-	65185	Switch Mounting Bracket
-	00254	Screw, 8-32 x 1/4" Fillister Head
23	23756	Flanged Reflector, 10" Dichroic

NOT SHOWN

65895	Lamphouse Top Cover Assembly
65866	Cap, Exhaust Stack
01736-1	Tamperproof Screw, 10-32 x 1/2" Holt Head
65149A	Screwdriver (for 1736-1)

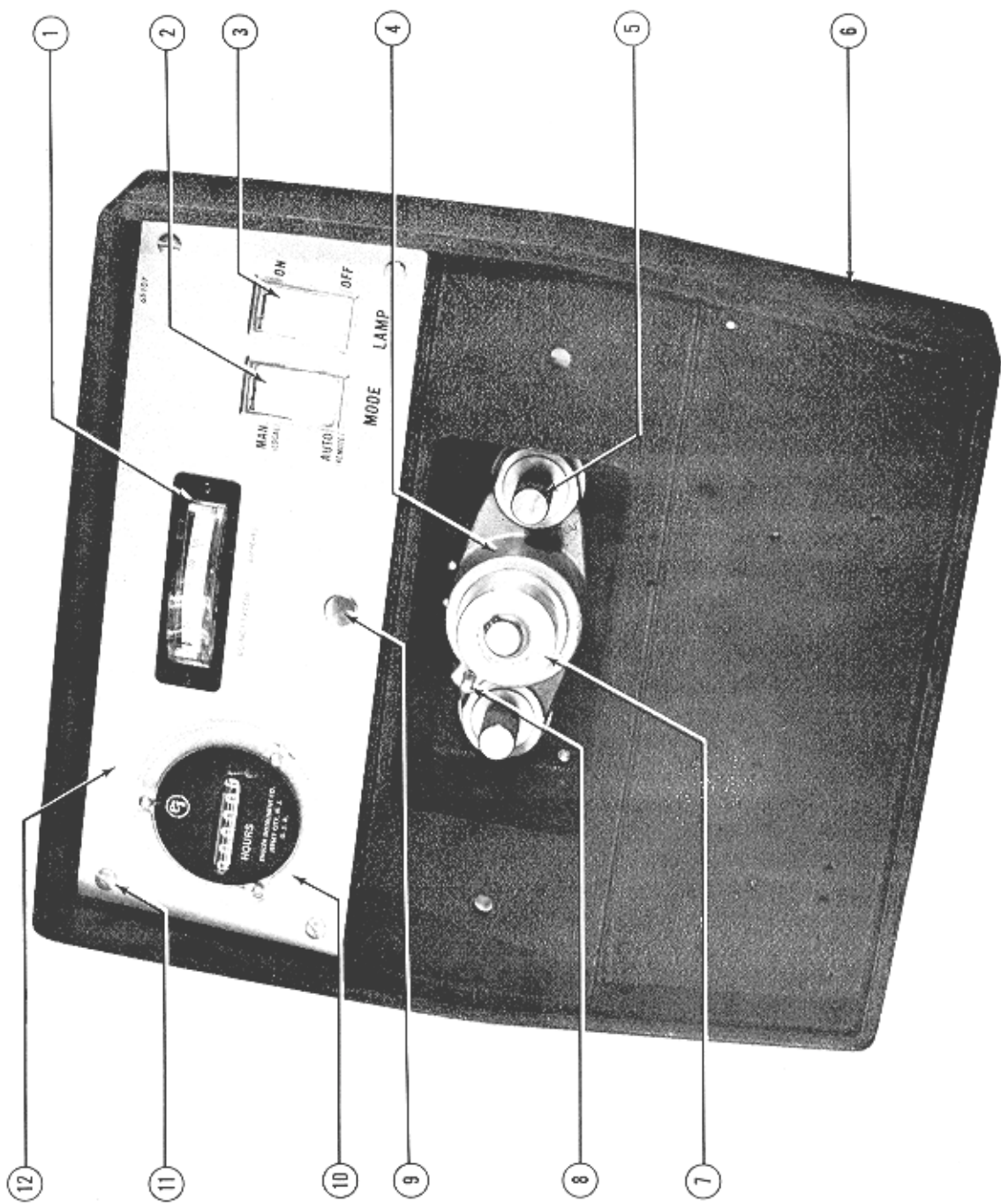

FIGURE 2

PARTS LIST

Figure 2

Item	Part No.	Description
1	65142	Ammeter (M2)
2	81276	MODE Switch (S3), AUTO-MAN.
3	81275	LAMP Switch (S2), ON-OFF
4	65116	Casting, Bulb Positioning Control
-	65197	Fender Washer, Inner
5	37985	Thumb Screw
-	15010	Compression Spring
-	65150	Fender Washer, Outer
6	65112	Lamphouse Back Casting
7	65959	Focus Screw & Bearing
8	65153	Focus Lock Screw
-	65154	Nylon Ball, 3/16" Diameter
9	76329	Plug Button, Chromed
10	65891	Elapsed Time Meter (M1), 60 Hz.
-	65870	Elapsed Time Meter, 50 Hz. (Export)
-	00953	Screw, 4-40 x 1/2" Round Head
-	01343	Lockwasher, #4
-	01620	Hexnut, 4-40 Brass
11	01382	Screw, 8-32 x 3/16" Bind Head
12	65107	Instrument Panel (less Components)

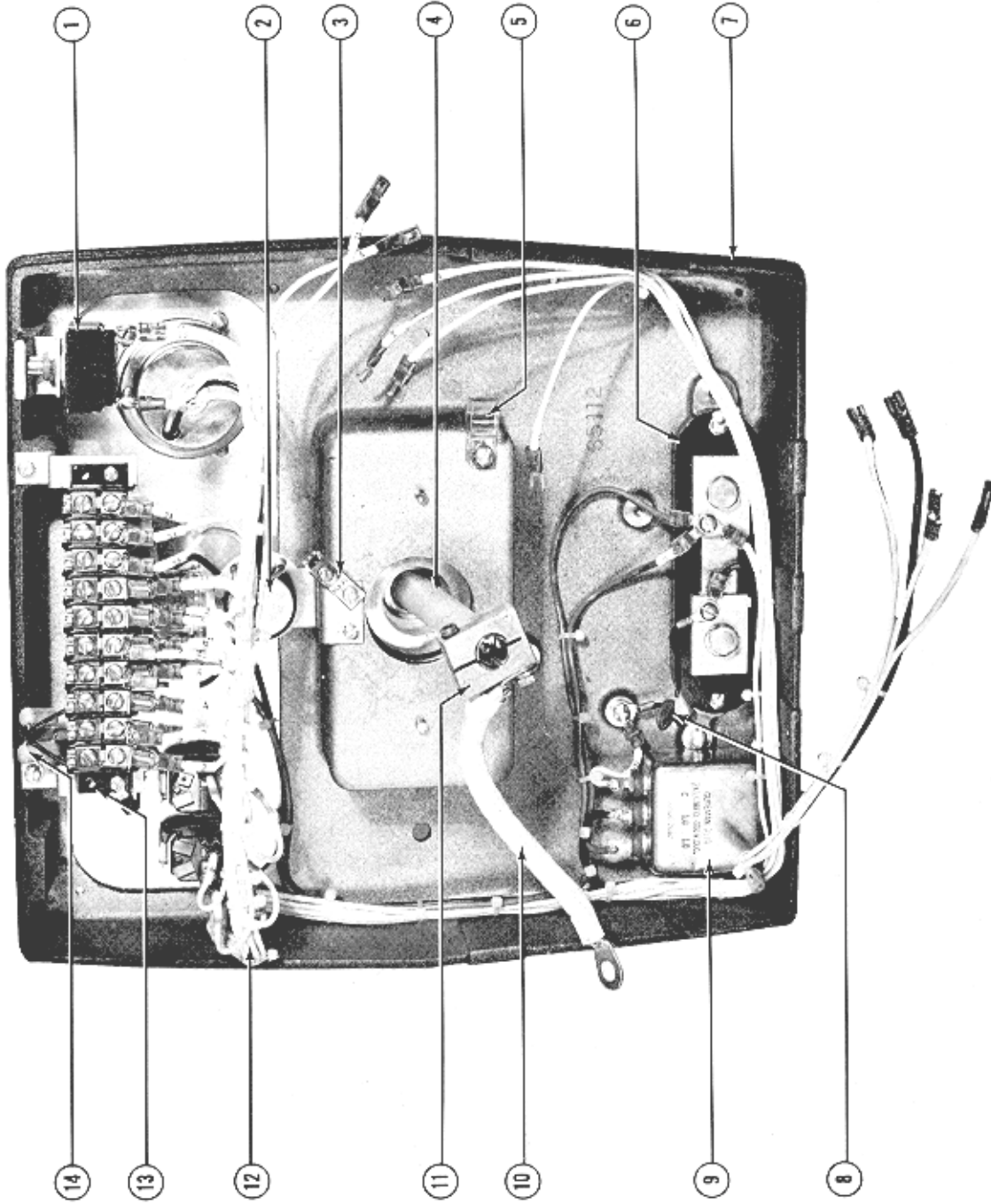

FIGURE 3

PARTS LIST

Figure 3

Item	Part No.	Description
1	80168	Top Cover Interlock Switch (S1)
-	01741	Lockwasher, 7/16"
-	65185	Switch Mounting Bracket
-	00254	Screw, 8-32 x 1/4" Fillister Head
-	00891A	Lockwasher, #8
2	65876	Potentiometer (early models*)
3	79131	Ground Terminal
4	65960	Rear Bulb Support Collet
-	21-48027	Collet Retaining Ring
5	M4361	Cable Clamp
-	00377	Screw, 10-24 x 1/4" Fillister Head
6	82167	Shunt (R1)
-	00385	Screw, 10-24 x 1/2" Fillister Head
-	00875	Split Lockwasher, #10
7	65935	Lampouse/Power Supply Cable Assembly
-	95119	Bushing, 1-1/4"
-	95120	Lock Nut, 1-1/4"
8	81947	Capacitor (C5)
-	00381	Ground Screw, 10-24 x 5/8" Fillister Head
9	80177	Capacitor (C4A, C4B)
-	00375	Screw, 10-24 x 3/16" Fillister Head
-	00885	Lockwasher, #10
10	65966	Igniter Lead & Clamp Assembly
-	00685	Screw, 1/4-20 x 3/8" Hex Head
-	00876	Split Lockwasher, 1/4"
11	65131	Contact Clamp (incl. with Item 10)
-	01532	Clamping Screw, 8-32 x 7/8" Socket Head
12	65951	Lampouse Wire Harness Assembly
13	65134	Barrier Strip, (10) Terminal
-	00182	Screw, 6-32 x 7/16" Fillister Head
-	65160	Barrier Strip Mounting Bracket
-	00255	Screw, 8-32 x 5/16" Fillister Head
-	00891A	Lockwasher, #8
14	65890	Capacitor Assembly (C1, C2, C3)
-	00182	Screw, 6-32 x 7/16" Fillister Head

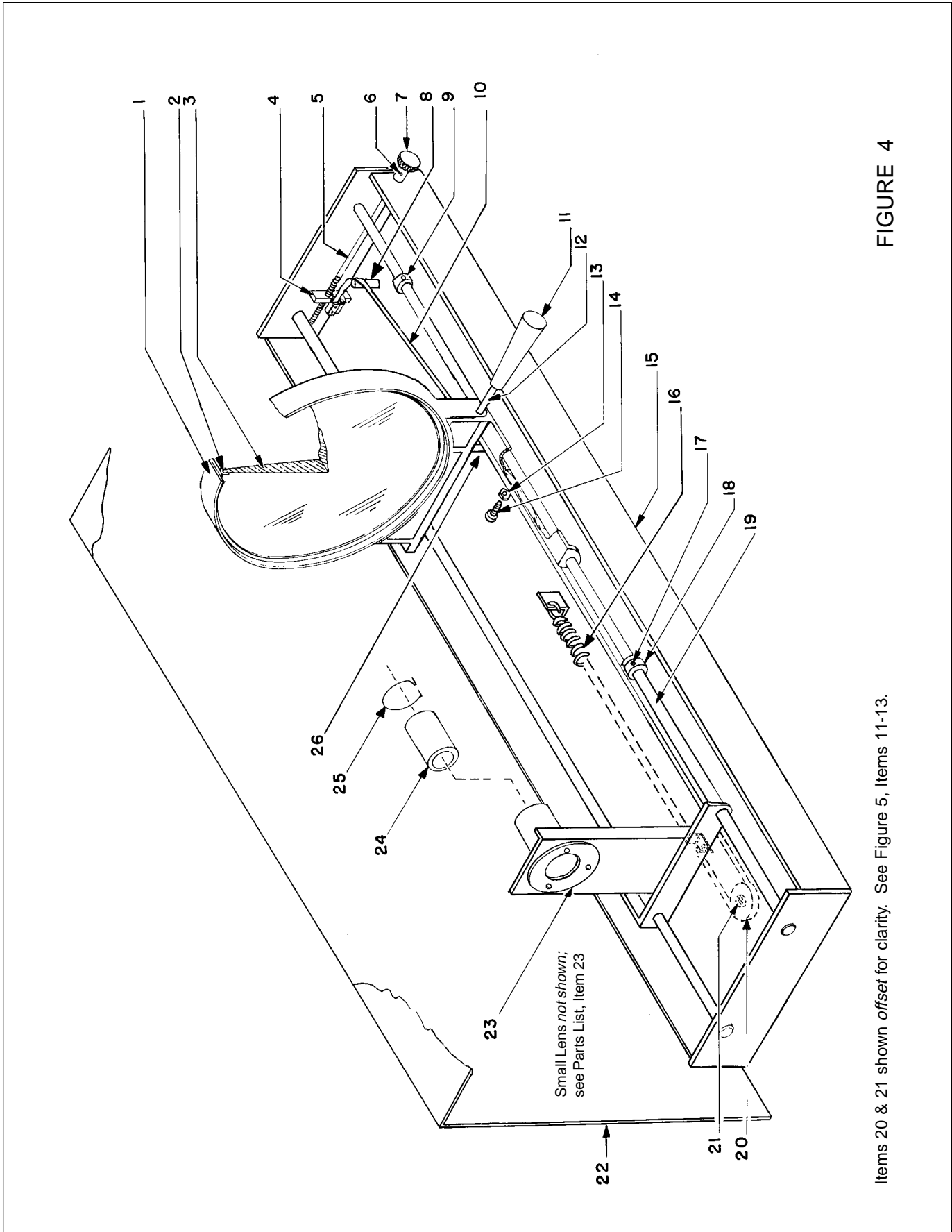

FIGURE 4

Items 20 & 21 shown offset for clarity. See Figure 5, Items 11-13.

PARTS LIST

Figure 4

Item	Part No.	Description
1	51875	Carriage Casting, Large Lens
2	51493	Lens Retaining Ring
-	51492	Rubber Lens Cushion
-	00217	Screw, 8-32 x 5/16" Round Head
-	00830	Flatwasher, #8 Brass
-	00866	Flatwasher, #10
3	51102	Large Lens
4	51133	Lens Focus Block
5	51489	Lens Focus Shaft
-	00866	Flatwasher, #10
-	01475	Cotter Pin, 1/16" x 3/8"
6	41-51170	Set Screw, Focus Knob
7	51168	Focus Knob, Lens Mechanism
8	51167	Post, Focus Ribbon
-	00490	Mounting Screw, 1/4-20 x 1/2" Flat Head
9	51114	Stop Collar
10	51992	Lens Focus Ribbon
11	51509	Handle, Red Plastic
12	48410	Handle Shaft
13	01752	Lock Nut, 1/4-20 Nylon Hex
14	01754	Friction Brake Screw, 1/4-20 x 1" Hex Head Nylon
15	48899	Base Pan, Welded Assembly
16	51162	Tension Spring
17	41-51178	Set Screw, 10-32 x 1/4"
18	51114	Stop Collar
19	51485	Slide Rod (Left & Right)
-	48127	Truarc Ring, #5100-56
-	48147	Truarc Ring, #5101-56
20	51157	Pulley, Focus Ribbon
21	51160	Pulley Stud
-	00830	Flatwasher, #8 Brass
22	48895	Lens Housing Welded Assembly
-	01307	Screw, 10-32 x 3/8" Pan Head
-	00541	Screw, 1/4-20 x 1/2" Pan Head
23	48896	Small Lens Carriage Welded Assembly
-	51101	Small Lens (not shown; mounts to 48896)
-	48404	Small Lens Mounting Plate (not shown; 2 req'd.)
-	48042	Mounting Tube (for Item 24 Lens)
-	00241	Tube Mounting Screw, 8-32 x 5/8" Flat Head

PARTS LIST, Figure 4 (continued)

Item	Part No.	Description
24	44239A	Projection Lens
25	83155	Retaining Clip, Projection Lens
26	51160	Pulley Stud
-	00830	Flatwasher, #8 Brass

NOT SHOWN

48891	Base Rail, Lamphouse & Lens Mechanism
49342	Hand Rail
01346	Screw, 5/16-18 x 1/2" Hex Head
00877	Split Lockwasher, 5/16"

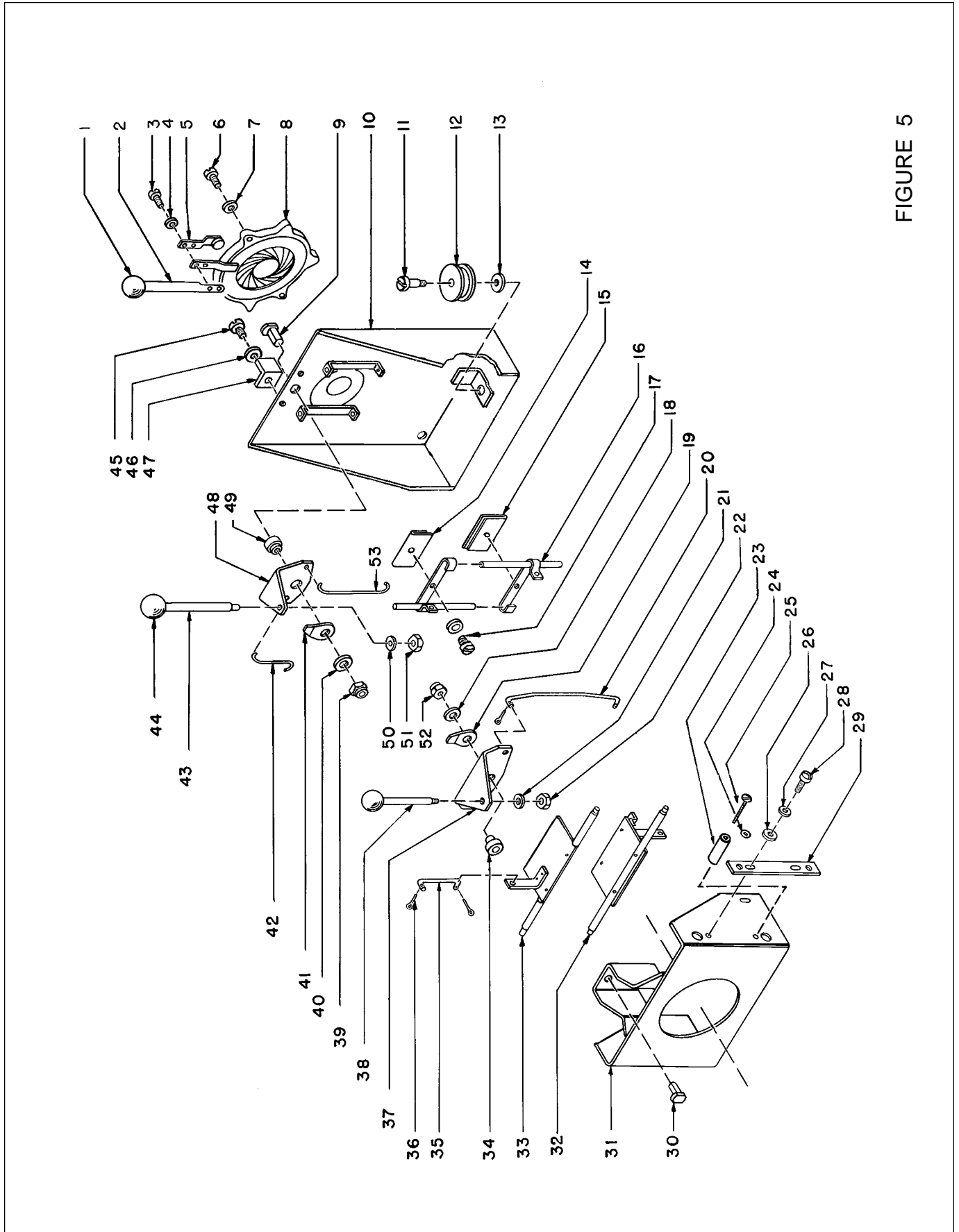

FIGURE 5

PARTS LIST

Figure 5

Item	Part No.	Description
1	10048A	Knob, Red Plastic
2	48402	Iris Shaft
3	00179	Screw, 6-32 x 1/4" Fillister Head
4	00892	Lockwasher, #6
5	51978	Friction Spring & Pad (for 51979)
6	00184	Screw, 6-32 x 5/8" Fillister Head
7	00892	Lockwasher, #6
8	51979	Iris (as shown; also see Figure 5A)
		<i>See Figure 5A for current configuration</i>
9	51226	Stud, Chopper Blade
10	51871	Aperture Support Plate, Welded Assembly
11	51160	Pulley Stud
12	51157	Small Pulley
13	00830	Flatwasher, #8 Brass
14	47191	Chopper Blade
15	47191	Chopper Blade
16	47982	Slide Assembly, Chopper Blade
17	00253	Screw, 8-32 x 3/16" Fillister Head
-	00891A	Lockwasher, #8
18	00853	Washer, 1/4" Steel, S.A.E.
19	51156	Friction Plate
20	51602	Pull Rod, Lower Fadeout Blade
21	00876	Split Lockwasher, 1/4"
22	00805	Hexnut, 1/4-20
23	51517	Spacer
24	00866	Flatwasher, #10
25	00400	Screw, 10-32 x 1-1/2" Fillister Head
26	00831	Flatwasher, #10; .036" Thick
27	01344	Lockwasher, #10
28	00378	Screw, 10-32 x 1/4" Fillister Head
29	51443	Pivot Shaft Retainer
30	51226	Stud, Chopper Blade
31	48898	Fadeout Mechanism Bracket, Welded Assembly
32	48878	Lower Fadeout Blade
33	48879	Upper Fadeout Blade
34	51153	Pivot Bushing
35	51515	Pull Rod, Upper Fadeout Blade
36	00919	Cotter Pin, 1/16" x 1/2"
37	51520	Fadeout Control Handle Bracket
38	51452	Handle, Fadeout Control
39	01406	Nut, 5-16-18 FlexLock Hex

PARTS LIST, Figure 5 (continued)

Item	Part No.	Description
40	00853	Washer, 1/4" Steel, S.A.E.
41	51156	Friction Plate
42	51498	Chopper Pull Rod, Short
43	51155	Handle, Chopper Control
44	10048A	Knob, Red Plastic
45	00254	Screw, 8-32 x 1/4" Fillister Head
46	00891	Lockwasher, #8
47	47170	Iris Stop Bracket
48	48406	Bracket, Chopper Control Handle
49	51153	Pivot Bushing
50	00876	Split Lockwasher, 1/4"
51	00805	Hexnut, 1/4-20
52	01406	Locknut, 5/16-18
53	51497	Chopper Pull Rod, Long

FIGURE 5A

Part No.	Description
01306	Screw, 6-32 x 5/16"
21-70029	Spring Washer
24369	Bell Crank
24372	Adapter Ring
24374	Iris
25034	Iris Clamp
25035	Link with Pins
41-51252	Screw, 8-32 x 5/8"
41-50325	Screw, 6-32 x 3/8"
41-51530	Shoulder Bolt
48402	Iris Control Handle

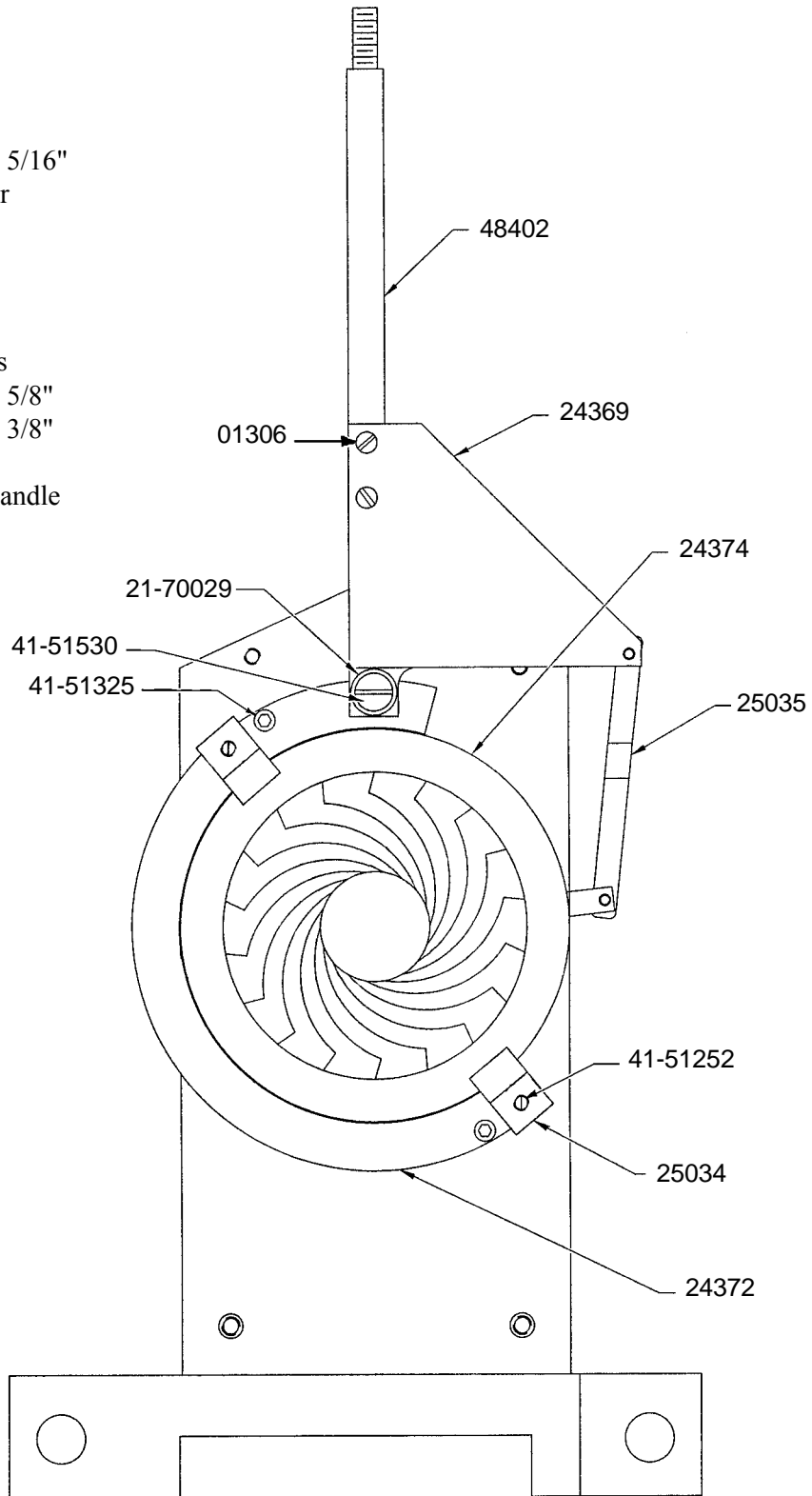

51850 BOOMERANG ASSEMBLY

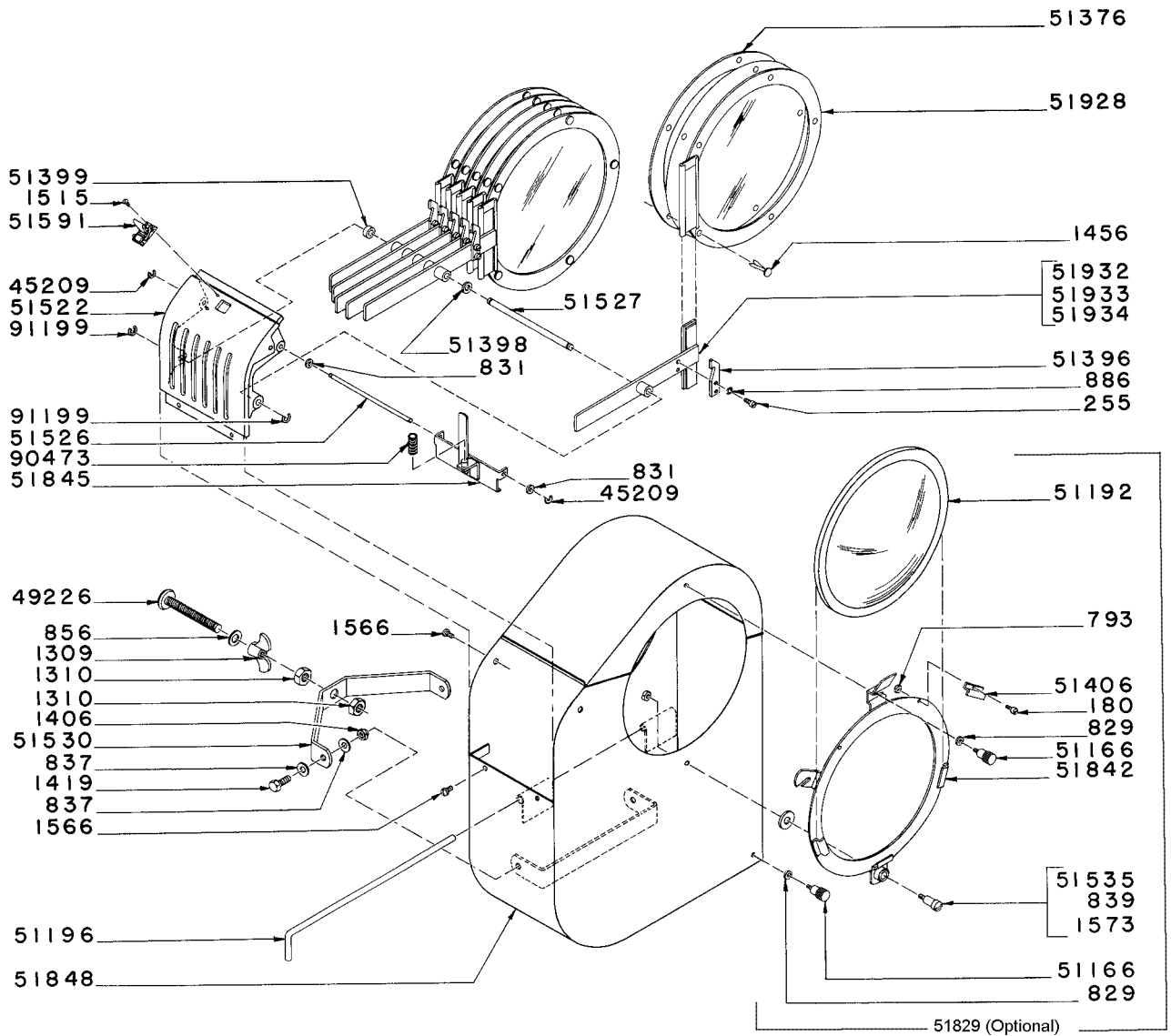

BOOMERANG PARTS LIST

Part No.	Description
51850	Boomerang Assembly
00180	Screw, 6-32 x 5/16" Fillister Head
00255	Screw, 8-32 x 5/16" Fillister Head
00793	Nut, 6-32, Steel
00829	Washer, #8 Brass, 3/8" O.D.
00831	Washer, #10 Brass, 7/16" O.D.
00837	Washer, 5/16" Brass, 3/4" O.D.
00839	Washer, 3/8" Brass, 7/8" O.D.
00856	Washer, 1/2" S.A.E.
00886	Lockwasher, #8 Split Ring
01309	Order 41-35065 Wing Nut 1/2-13
01310	Hex Half Nut, 1/2-13
01406	Locknut, 5/16-18 x 1/4"
01419	Screw, 5/16-18 x 3/4" Hex Head Cap
01456	Paper Fastener
01515	Screw, 4-40 x 1/4" Round Head
01566	Screw, 10-24 x 5/16" Pan Head
01573	Jam Nut, 1/4-20
45209	"E" Ring, 3/16"
49226*	Adjusting Screw (Replace with 51347*)
51166	Shoulder Screw
51192	Ultra Violet Filter
51196	Hinge Pin
51347*	Adjusting Screw (Mfr. 1991 and Later)
51376	Cover Plate, Color Frame
51396	Catch
51398	Nylon Spacer Washer
51399	Spacer
51406	Clip, U.V. Filter
51522	Frame, Color Disc Housing
51526	Shaft, Rocker Catch Pivot
51527	Shaft, Color Disc Pivot
51530	Yoke
51535	Screw, U.V. Filter Pivot
51591	Latch, Color Disc Housing
51842	U.V. Filter Support Frame Assembly
51845	Rocker Catch Assembly
51848	Housing, Welded Assembly
51928	Color Frame Slide Channel Assembly
51932	Arm Assembly (5-3/16")
51933	Arm Assembly (4-11/16")
51934	Arm Assembly (4-3/16")
90473	Spring
91199	"E" Ring, 5/16"

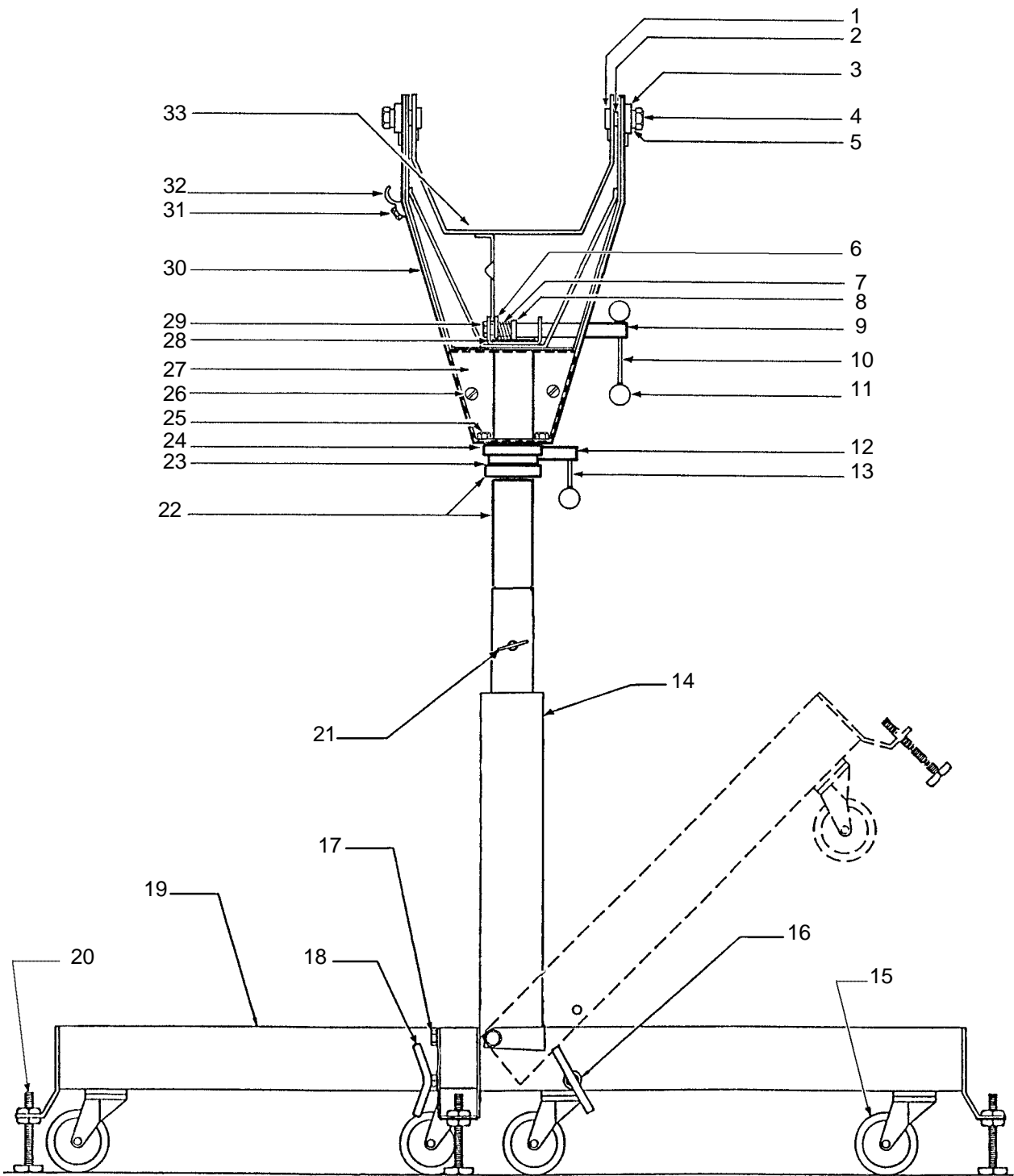

FOLDING BASE & STAND
 Assembly No. 65838

PARTS LIST
Folding Base & Stand

Item	Part No.	Description
1	49120	Tilt Axis Bolt
2	02411	Washer, 1.25" O.D. x .640" I.D.
3	49121	Washer, Tilt Axis
4	41-35020	Hexnut, 3/8-16
5	00845	Flatwasher, 3/8" S.A.E.
6	49126	Clamping Plate
7	49125	Clamping Spring, Compression
8	49124	Clamp Bushing
9	49129	Shaft, Tilt Clamp
10	49130	Handle, Clamp Shaft
11	10048A	Knob, Red Plastic
12	49179	Swivel Clamping Nut
13	49114	Handle Stud, Swivel Clamp
-	10048A	Knob, Red Plastic
14	83742	Base Column, Welded Assembly
15	49208	Swivel Caster
16	00854	Flatwasher, 3/8" S.A.E.
17	41-51397	Screw, 7/16-14 x 3" Hex Head
-	41-70007	Flatwasher, 7/16"
-	41-35056	Nut, 7/16-14 FlexLock
18	83745	Leg T-Bolt, Welded Assembly
19	83744	Base Leg, Welded Assembly
20	49226	Leveling Foot
-	00919	Lock Nut, 1/2-13 Hex
21	48395	Height Adjust Pin, 3/8" Diameter
22	65824	Inner Tube & Ring Welded Assembly
23	48399	Bronze Washer
24	83381	Collar, Swivel Clamp
25	00687	Screw, 1/4-20 x 1/2" Hex Head
26	01304	Screw, 8-32 x 5/16" Pan Head
27	48394	Yoke Cover Plate
28	65431	Inner Tube Retaining Collar
29	01317	Screw, 1/2-13 x 2-1/2" Hex Head
30	65823	Yoke, Welded Assembly
31	00689	Screw, 1/4-20 x 5/8" Hex Head
32	83341	Cable Clamp
33	48884	Saddle & Quadrant Plate, Welded Assembly

ASSEMBLIES

65838	Base & Stand, Complete (Items 1-33)
18765	Folding Base Assembly (Items 14-20)

Free Manuals Download Website

<http://myh66.com>

<http://usermanuals.us>

<http://www.somanuals.com>

<http://www.4manuals.cc>

<http://www.manual-lib.com>

<http://www.404manual.com>

<http://www.luxmanual.com>

<http://aubethermostatmanual.com>

Golf course search by state

<http://golfingnear.com>

Email search by domain

<http://emailbydomain.com>

Auto manuals search

<http://auto.somanuals.com>

TV manuals search

<http://tv.somanuals.com>