

# SUPERO®

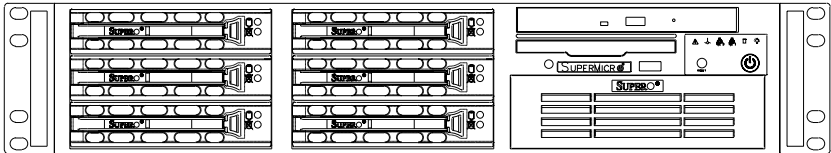

(SC823T/SC823S)

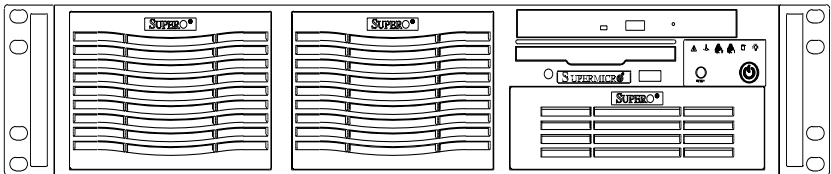

(SC823i)

## SC823 CHASSIS USER'S GUIDE

1.0

---

The information in this User's Guide has been carefully reviewed and is believed to be accurate. The vendor assumes no responsibility for any inaccuracies that may be contained in this document, makes no commitment to update or to keep current the information in this manual, or to notify any person or organization of the updates. **Please Note: For the most up-to-date version of this manual, please see our web site at [www.supermicro.com](http://www.supermicro.com).**

SUPERMICRO COMPUTER reserves the right to make changes to the product described in this manual at any time and without notice. This product, including software, if any, and documentation may not, in whole or in part, be copied, photocopied, reproduced, translated or reduced to any medium or machine without prior written consent.

IN NO EVENT WILL SUPERMICRO COMPUTER BE LIABLE FOR DIRECT, INDIRECT, SPECIAL, INCIDENTAL, OR CONSEQUENTIAL DAMAGES ARISING FROM THE USE OR INABILITY TO USE THIS PRODUCT OR DOCUMENTATION, EVEN IF ADVISED OF THE POSSIBILITY OF SUCH DAMAGES. IN PARTICULAR, THE VENDOR SHALL NOT HAVE LIABILITY FOR ANY HARDWARE, SOFTWARE, OR DATA STORED OR USED WITH THE PRODUCT, INCLUDING THE COSTS OF REPAIRING, REPLACING, INTEGRATING, INSTALLING OR RECOVERING SUCH HARDWARE, SOFTWARE, OR DATA.

Any disputes arising between manufacturer and customer shall be governed by the laws of Santa Clara County in the State of California, USA. The State of California, County of Santa Clara shall be the exclusive venue for the resolution of any such disputes. Supermicro's total liability for all claims will not exceed the price paid for the hardware product.

---

Unless you request and receive written permission from SUPER MICRO COMPUTER, you may not copy any part of this document.

Information in this document is subject to change without notice. Other products and companies referred to herein are trademarks or registered trademarks of their respective companies or mark holders.

Copyright © 2004 by SUPER MICRO COMPUTER INC.  
All rights reserved.

**Printed in the United States of America**

---

## **Table of Contents**

### **Chapter 1: Safety Information and Technical Specifications ..... 1-4**

<b>1-1. Electrical Safety Guidelines .....</b>	<b>1-4</b>
<b>1-2. General Safety Guidelines .....</b>	<b>1-5</b>
<b>1-3. ESD Safety Guidelines .....</b>	<b>1-6</b>
<b>1-4. Operation Safety Guidelines .....</b>	<b>1-6</b>
<b>1-5. Product Compliance Information .....</b>	<b>1-8</b>
<b>1-6. Packing List and the SC823 Specifications .....</b>	<b>1-9</b>

### **Chapter 2: Chassis Description and Installation Procedures ..... 2-1**

<b>2-1. Chassis Description .....</b>	<b>2-1</b>
A. Contents of the Accessory Kit .....	2-1
B. Chassis Front View and the Front Control Panel .....	2-2
C. Chassis Rear View and the Back Panel .....	2-4
<b>2-2. Chassis Installation .....</b>	<b>2-6</b>
A. Important Safety Guidelines .....	2-6
B. Tools Needed .....	2-6
C. Removing the Top Cover of the Chassis.....	2-7
D1. Accessing the SCA/SATA Drive Tray and Installing a Hard Disk ..	2-8
D2. Accessing the IDE Drive Tray and Installing a Hard Disk .....	2-9
E. Accessing the Front Chassis Fans and Installing the Air Shroud ..	2-10
F. Accessing the Redundant Power Supply .....	2-11
G. Installing the Motherboard .....	2-12
H. Installing Chassis Rails .....	2-13
I. Rack Installation .....	2-15

# Chapter 1-Safety Information and Technical Specifications

## 1-1 Electrical Safety Guidelines



**Warning:** *To avoid electrical shock, check the power cords as follows:*

### **Checking the Power Cords**

- Use the exact type of power cords as required.
- Be sure to use power cord(s) that came with safety certifications.
- The power cord(s) must be compliant with the AC voltage requirements in your region.
- The power cord plug cap must have an electrical current rating that is at least 125% of the electrical current rating of this product.
- The power cord plug cap that plugs into the AC receptacle on the power supply must be an IEC 320, sheet C13, type female connector.
- Be sure to disconnect the power supply before accessing the SC823 chassis or its components.
- Plug the Power cord(s) into a socket that is properly grounded before turning on the power.



**Warning:** *Follow the guidelines below to avoid possible damages to the system or injury to yourself:*

### **General Electrical Safety Guidelines**

- Be aware of the locations of the power switches on the chassis and in the room, so you can disconnect the power supply if an accident occurs.
- Take extra precautionary measures when working with high voltage components. It is not recommended to work alone.
- Before removing or installing main system components, be sure to disconnect the power first. Turn off the system before you disconnect the PS.
- Use only one hand when working with powered-on electrical equipment to avoid possible electrical shock.

- Use rubber mats specifically designed as electrical insulators when working with computer systems.
- The power supply or power cord must include a grounding plug and must be plugged into grounded outlets.
- Motherboard Battery: CAUTION - Make sure not to install the onboard battery upside down to avoid possible explosion. Make sure that the positive side should be facing up on the motherboard. This battery must be replaced only with the same or an equivalent type recommended by the manufacturer. Dispose of used batteries according to the manufacturer's instructions.
- CD-ROM Laser: CAUTION - Do not open the enclosures of power supplies or CD ROM to avoid injury.

### 1-2 General Safety Guidelines



***Warning:*** Follow these rules to ensure general safety:

Keep the area around the SC823 chassis clean and free of clutter.

- To avoid injuries to the back, be sure to use your leg muscles, keep your back straight, and bend your knees, when lifting the system.
- After removing the components or chassis covers from the system, place them on a table for safeguard.
- Avoid wearing loose clothing to preventing it from coming into contact with
- Be sure to remove any jewelry or metal objects before working on the chassis to avoid short circuits should these objects come into contact with power circuits.
- After accessing the interior of the chassis, be sure to close the chassis with chassis covers and secure the chassis to the racks with screws.

## 1-3 ESD Safety Guidelines



Electric Static Discharge (ESD) can damage electronic components. To prevent damage to your system board, it is important to handle it very carefully. The following measures are generally sufficient to protect your equipment from ESD.

- Use a grounded wrist strap designed to prevent static discharge.
- Keep all components and printed circuit boards (PCBs) in their antistatic bags until ready for use.
- Touch a grounded metal object before removing the board from the antistatic bag.
- Do not let components or PCBs come into contact with your clothing, which may retain a charge even if you are wearing a wrist strap.
- Touch a grounded metal object before removing the board from the antistatic bag.
- Handle a board by its edges only; do not touch its components, peripheral chips, memory modules or contacts.
- When handling chips or modules, avoid touching their pins.
- Put the motherboard and peripherals back into their antistatic bags when not in use.
- For grounding purposes, make sure your computer chassis provides excellent conductivity between the power supply, the case, the mounting fasteners and the motherboard.

## 1-4 Operation Safety Guidelines



**Warning:** For proper cooling, make sure to install all chassis covers before turning on the system. If this rule is not strictly followed, warranty may become void. Do not open the casing of a power supply. Power supplies can only be accessed and serviced by a qualified technician of the manufacturer.



To avoid personal injury and property damage, please carefully follow all the safety steps listed below:

**Before accessing the chassis:**

1. Turn off all peripheral devices connected to the SC823.
2. Press the power button to power off the system.
3. Unplug all power cords from the system or the wall outlets.
4. Disconnect all the cables and label the cables for easy identification.
5. Use a grounded wrist strap designed to prevent static discharge when handling components.

**Removing the chassis covers:**

After completing the above steps, you can remove the covers and install components/peripheral devices into the chassis as described in Chapter 2.

1. Unlock and remove the screws and fasteners to remove the cover or components.
2. Save all the screws and fasteners for later use. (If necessary, label these screws or fasteners for easy identification.)
3. Follow the instruction given in Chapter 3 to remove the chassis covers.

**Reinstalling the chassis covers:**

To maintain proper system cooling and airflow, do not operate the system without installing all chassis covers back to the chassis. To reinstall the chassis covers, please follow the steps listed below:

1. Make sure that all components and devices are securely fastened on the chassis and there are no loose parts/screws inside the chassis.
2. Make sure that all cables are properly connected to the connectors and ports.
3. Use the original screws or fasteners to install the covers to the chassis.
4. Be sure to lock to the chassis or the system to prevent unauthorized access.
5. For proper cooling, enclose the chassis with covers before operating the system.

**Before installing the chassis into a rack:**

1. Make sure that the rack is securely anchored onto an unmovable surface or structure before installing the chassis into the rack.
2. Unplug the power cord(s) of the rack before installing the chassis into the rack.
3. Make sure that the system is adequately supported and that all the components are securely fastened to the chassis to prevent components from falling off from the chassis.
4. Be sure to install an AC Power Disconnect for the entire rack assembly and this Power Disconnect must be clearly marked.
5. The rack assembly shall be properly grounded to avoid electric shock.
6. The rack assembly must provide sufficient airflow to the chassis for proper cooling.

## **1-5 Product Compliance Information**

The SC823 Chassis is compliant with the following safety standards/requirements:

### **Product Safety**

- \*Canada/USA--UL60 950-CSA60 950
- \*European Union--EN 60 950
- \*International--IEC 60 950

### **Electromagnetic Compatibility (EMC)-Emissions**

- \*European Union--EN55022: 1994
- \*International--CISPR 22
- \*USA--Title 47 CFR, Part 15

### **Electromagnetic Compatibility-Immunity**

- \*European Union--EN55024: 1998
- \*International--CISPR 24

### **Power Line Harmonics/Voltage Flicker**

- \*European Union--EN61000-3-2/EN61000-3-3
- \*International--IEC61000-3-2



## 1-6 Packing List and the SC823 Specifications

### A. The SC823 Series chassis contains the following:

- One (1) 1.44" floppy drive
- One (1) slim CD-ROM drive (\*For 823S-R500LP, 823S-R500RC, 823T-R500RC, 823i-R500RC only)
- One (1) 5.25" drive bay
- One (1) I/O shield
  
- SCSI Accessories (\*For SC823S only)  
 One (1) SCSI backplane  
 One (1) SCSI Ultra 320 Cable  
 Six (6) SCSI drive carriers
  
- SATA Accessories (\*For SC823T only)  
 One (1) SATA backplane  
 One (1) SATA Activity LED cable  
 Six (6) SATA drive carriers
  
- IDE Accessories (\*For SC823i only)  
 Two (2) IDE drive carriers  
 One (1) IDE cable

### B. SC823 Specifications

#### For the SC823-IDE Models>(\*823i-550LP/823i-R500RC)

SC823-IDE			
Component	Part#	Qty	Notes
IDE Drive Tray	CSE-PT18 (B)	2	
8 cm Hot -Swap Chassis Fan	Fan-0070	4	
550W Power Supply	PWS-0047	1	(*for 823i -550LP)
500W Power Supply	PWS-0049	2	(*for 823i -R500RC)
Floppy Drive	FPD-PNSC-02(01)	1	
Rackmount Hardware	CSE-PT 25	1	
CD ROM	CDM-TEAL-24(B)	1	(*for 823i -R500RC)

**For the SC823-SCSI Models>(\*823S-R500LP/R500RC/R550LP)**

<b>SC823S-SCSI</b>			
<b>Component</b>	<b>Part#</b>	<b>Qty</b>	<b>Notes</b>
SCA Drive Tray	CSE-PT17 (B)	6	
8 cm Hot -Swap Chassis Fan	Fan-0070	4	
550W Power Supply	PWS-0047	1	(*for 823S-550LP)
500W Power Supply	PWS-0049	2	(*for 823S-R500RC/R500LP)
6-port SCSI Backplane	CSE-SCA-822	1	
SCSI Cable	CBL-033-U320	1	
Floppy Drive	FPD-PNSC-02(01)	1	
CD ROM	CDM-TEAC-024(B)	1	(*for Redundant Chassis)
Rackmount Hardware	CSE-PT-25	1	

**For the SC823-SATA Models>(\*823T-R550LP/823T-R500RC)**

<b>SC823T</b>			
<b>Component</b>	<b>Part#</b>	<b>Qty</b>	<b>Notes</b>
SATA Drive Tray	CSE-PT17 (B)	6	
8 cm Hot -Swap Chassis Fan	Fan-0070	4	
500W Power Supply	PWS-0049	2	(*for 823T-R500RC)
550W Power Supply	PWS-0047	1	(* for 823T-550LP)
6-port SATA Backplane	CSE-SATA-822	1	
SATA Activity LED Cable	CBL-0077	1	
Floppy Drive	FPD-PNSC-02(01)	1	
CD ROM	CDM-TEAC-024(B)	1	(*for 823T-R500RC)
Rackmount Hardware	CSE-PT-25	1	

**C. SC823 Power Supply Specifications**

<b>Power supply spec</b>	<b>500W</b>	<b>550W</b>
Mfr. Model#	SP502-2S	SP552-2C
Mfr. Part#	PWS-0049	PWS-0047
Rated AC input voltage	100-240V AC	100-240V AC
Rated input frequency	50-60 Hz	50-60 Hz
Rated input current	10A (115V)	9A (115V)
	5A (230V)	3.5A (230V)
Rated output power	500W	550W
Maximum rated BTU	2630 BTUs/Hr	2910 BTUs/Hr
Nominal DC output		
+3.3V	21A	30A
+5V	30A	35A
+12V	39A	34A
-5V	N/A	0.8A
-12V	1A	1A
+5Vsb	2A	2A

**D. Serial ATA Back Panel (\*SC823T only)**

**D-1 Jumper Settings and Pin Definitions**

Jumpers	Default Settings	Notes
JP18	Open	Buzzer Reset (*Note Below)
JP25	1-2	Overheat Temperature at 50 <sup>0</sup> C
JP26	Open	Common Act In and Act#0-#5 In

**D-2 Jumper Locations**

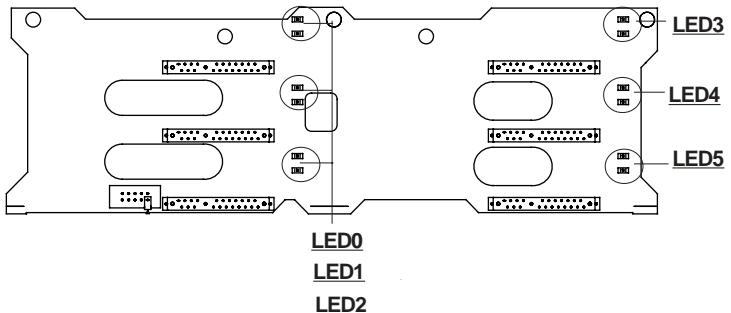
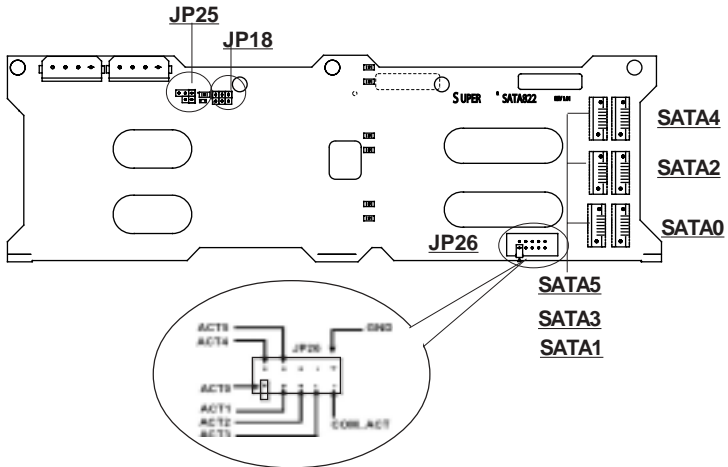

### E. SCSI Back Panel (\*SC823S Only)

#### E-1 Jumper Settings and Pin Definitions

Jumpers	Default Settings	Notes
JP18	Closed	Buzzer Unable/Disable (*Open: Disable, Closed: Enable)

#### E-2 Jumper Locations

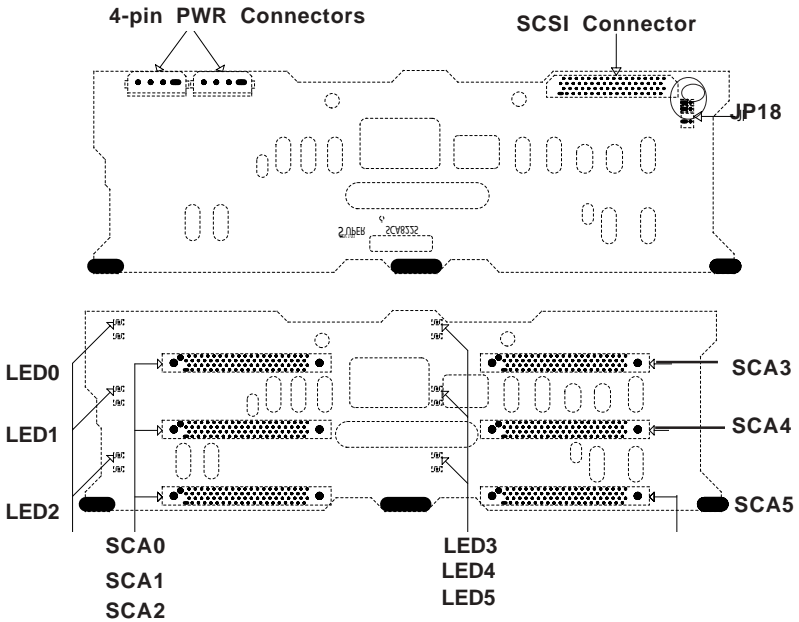

## Chapter 2: Chassis Description and Installation Instructions

### 2-1 Chassis Description

#### A. Contents of the Accessory Kit:

The following items are included in the Accessory Kit:

##### M/B Standoffs

**A** M5 x 6-32 x 6.5L



**B** M5 x 6-32 x 7.7L



##### Screws for M/B

**C** Pan head with lock 6-32 x 4.5 mm



##### Screws for HDD

**D** Flat head 6-32 x 5mm



##### Screws for Drives

**E** Pan head 6-32 x 5m



**F** Round head M2 x 3mm



**G** Round head M3 x 5 mm



**H** Pan head M3 x 5mm



##### RAIL

**I** Round head M4 x 4 mm



**J** Flat head M5 x 12 mm



**K** Washer for M5



## B. Chassis Front View and the Front Control Panel

### Chassis Front Panel

#### The SC823T/SC823S Series

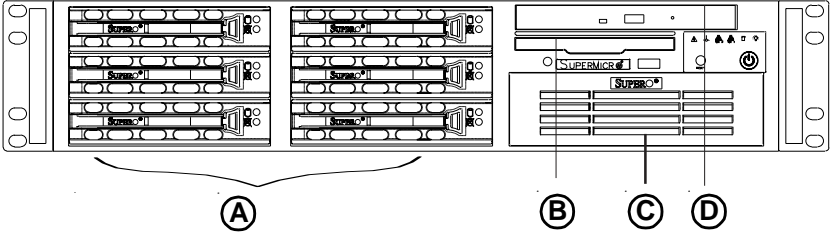

#### Front Panel I/O Device Definitions (\* for the SC823T/SC823S Series)

- A. SCA Drive Trays(6)
- B. Floppy Disk(1)
- C. 5.25" Drive Bay(1)
- D. CD ROM(1) (\*Redundant Chassis only)

#### The SC823i Series

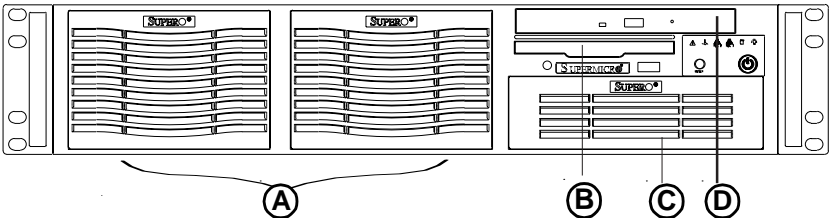

#### Front Panel I/O Device Definitions (\* for the SC823i Series)

- A. IDE Drive Trays(2)
- B. Floppy Disk(1)
- C. 5.25" Drive Bay(1)
- D. CD ROM(\*823i-R500RC only)

**LED Panel**

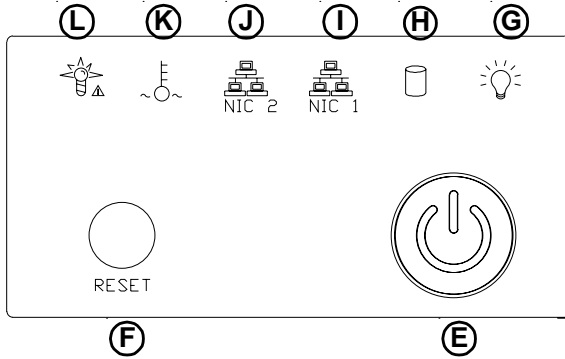

**LED and Button Definitions**

- E. Power Button
- F. Reset Button
- G. Power Indicator
- H.HDD Activity
- I. LAN1
- J. LAN2
- K. Overheat
- L. System Alert/Power Failure (\*for Redundant PS only)

**LED Button Descriptions**

LED Button	Color	Condition	Description
Power	Green	On	System On
		Off	System Off
HDD	Amber	Blink	HDD Activity
		Off	No Activity
LAN1 & LAN2	Green	On	Linked
		Blink	LAN Activity
		Off	Disconnected
Overheat	Red	On	System Overheat
		Off	System Normal
System Alert/ Power Failure	Red	On	1 or more PWR modules failure
		Off	System Normal

**C. Chassis Rear View and the Back Panel**

**SC823 Chassis Rear View (\*SC823T/823S/823i-LP Models)**

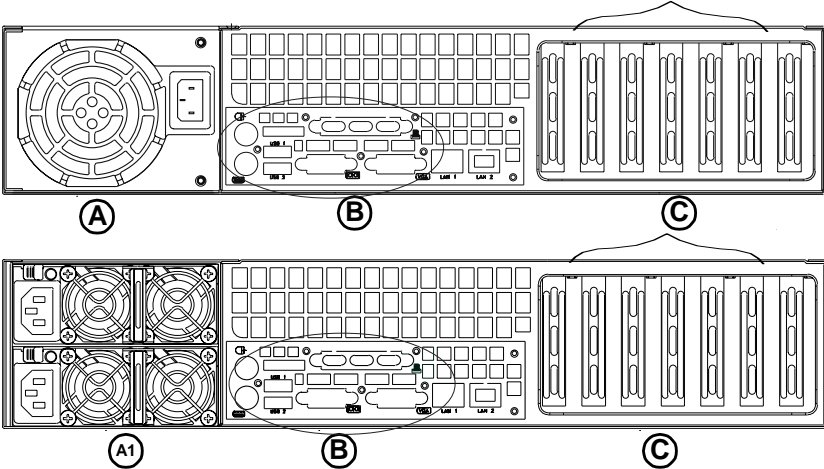

**Back Panel Devices (\*P/N: CSE-PT21)**

- A. Power Supply                      A1. Redundant Power Supply
- B. Back Panel I/O Ports
- C. Low Profile Expansion Slots(7)

**SC823 Chassis Rear View (\*SC823T/823i-RC Models)**

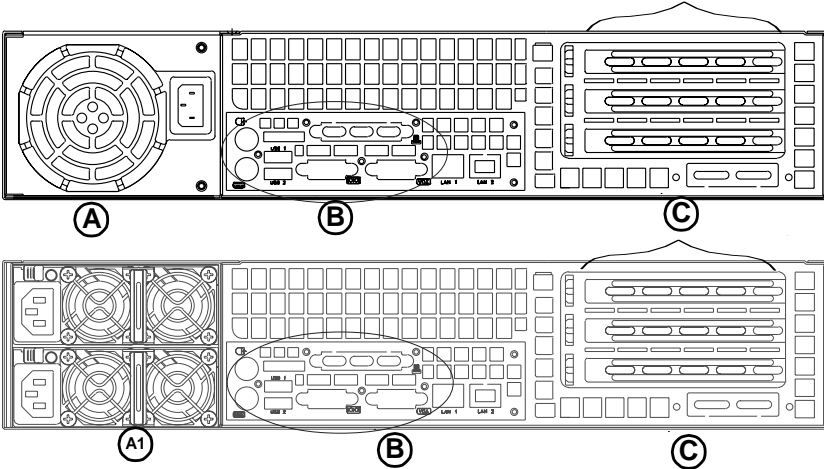

**Back Panel Devices (\*P/N: CSE-PT22)**

- A. Power Supply                      A1. Redundant Power Supply
- B. Back Panel I/O Ports
- C. Full Size Riser-card Slots(3)



**\*I/O Back Panel (\*installed on the back panel-See Page 2-4)**

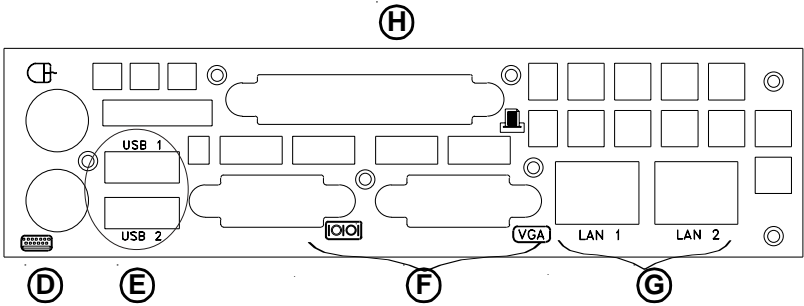

**\*I/O Back Panel**

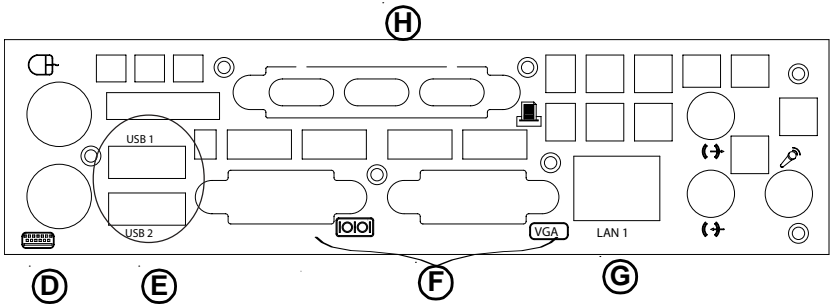

**Back Panel I/O Port Definitions**

- D. Keyboard & Mouse
- E. USB Ports
- F. COM/Video Ports
- G. LAN1 (& LAN2)
- H. Parallel Port

(\*Note: The actual I/O Configuration of your system might be different from the one shown above.)

**Power Module LED Descriptions (\*For Redundant Power Supply only)**

Power Module LED	Color Condition	Description
	Green	Power Supply DC On
	Amber	Power Supply Standby
	Off	No AC Power to the system

## 2-2 Chassis Installation

### **A. Important Safety Guidelines**



This product shall only be accessed, assembled and serviced by technically qualified personnel or technicians.

To avoid personal injury and property damage, please read all the information provided in Chapter 1, and carefully follow all the Safety Guidelines listed before accessing or servicing the SC823 or its components. For your convenience, some Safety Steps are also listed below.

### **Safety Steps**

#### **Before accessing the chassis:**

1. Turn off all peripheral devices and turn off the power supply connected to the SC823.
2. Unplug all power cords from the system or the wall outlets.
3. Disconnect all the cables and label the cables for easy identification.
4. Use a grounded wrist strap designed to prevent static discharge when handling components.

#### **Removing the chassis covers:**

After completing the above steps, you can remove the chassis covers and install components and devices into the chassis as described in this chapter.

1. Press the tabs or the screws to loosen and remove the cover or the components from the chassis.
2. Save all the screws and fasteners for later use. (If necessary, label these screws or fasteners for easy identification.)
3. Follow the instructions given in this chapter to remove the chassis covers.

### **B. Tools needed**

1. Phillips Screw Driver
2. Antistatic Strap

### **C. Removing the Top Cover of the SC823 Chassis**

Before installing any components, replacing chassis fans or accessing the motherboard, you will first need to remove the top cover.

#### **Procedures**

1. Press the release tabs to release the cover from its locking position.

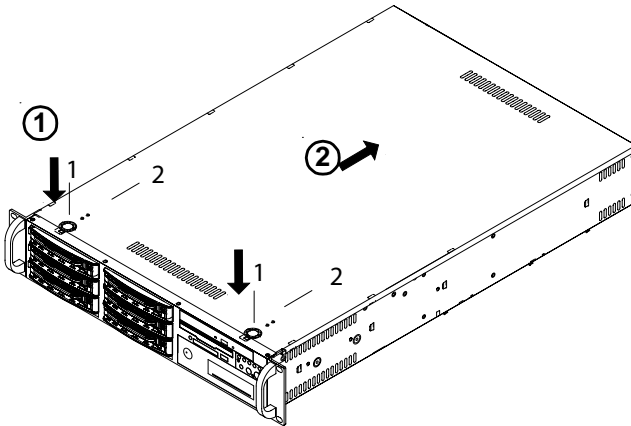

2. Once the top cover is released from its locking position, push the cover toward the rear side and slide it out from the chassis.

**D1. Accessing the SCSI (or SATA) Drive Tray and Installing a Hard Disk(\*For the SC823S/823T series)**

To install the SCA(SATA) drive into the chassis, you need to first remove the SCA(SATA) drive tray from the chassis.

**Procedures**

1. Press the release tab located on the drive tray door to release the drive tray from its locking position as shown below.
2. Pull the drive tray door upward and then pull the drive tray out from the chassis.

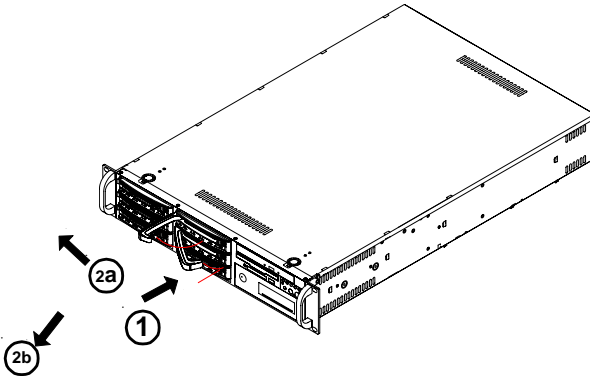

3. Remove the screws to loosen the drive tray. Once loosened, pull it out from its housing. Then, mount a hard drive in the drive tray and secure it with screws as shown below.

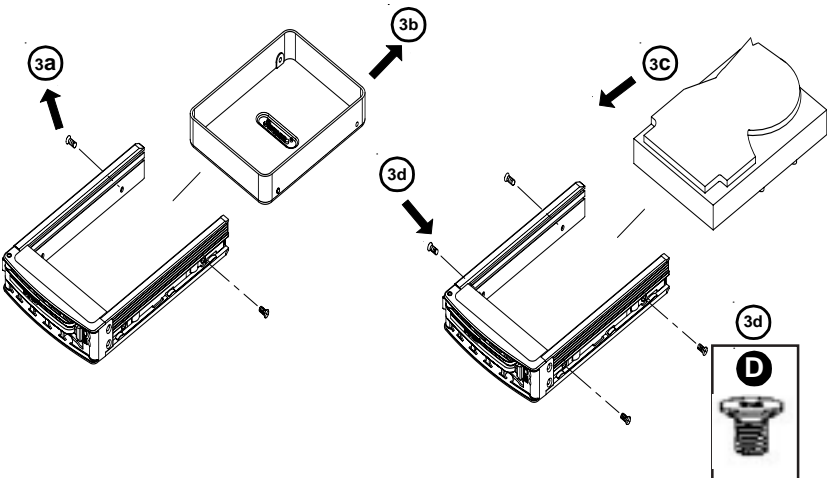

**SCA (SATA) Drives (\*SC823S/823T Series)**

**D2. Accessing the IDE Drive Tray and Installing a Hard Disk**  
**(\*For the SC823i Series)**

To install the IDE drive into the chassis, first, you need to remove the top cover; then, you need to remove the IDE drive tray from the chassis.

**Procedures**

1. Remove the screws from the top of the IDE drive as shown below.
2. Once the top cover and the screws are removed, press on the back side of the IDE drive tray and push it out from the chassis.

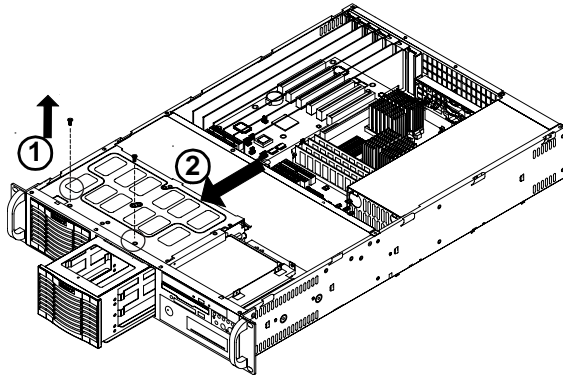

3. Remove the screws to loosen the drive tray. Once loosened, pull it out from its housing. Then, mount a hard drive in the drive tray and secure it with screws as shown below.

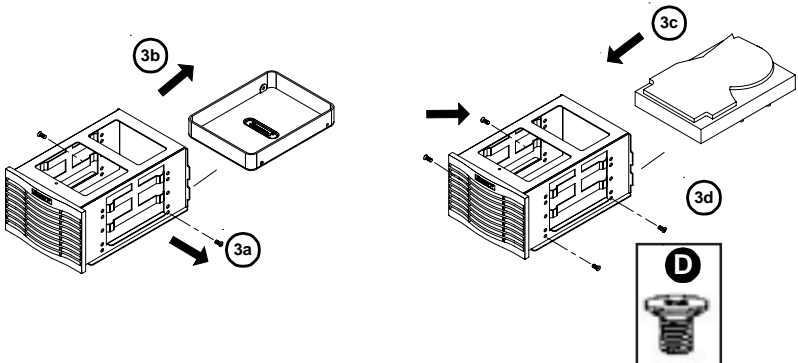

**IDE Drives(\*SC823i Series)**

## **E. Accessing the Front Chassis Fans and Installing the Air Shroud**

### **Procedures: Accessing Chassis Fans**

1. Press the release tab located on the left side of the front chassis fan (when facing the front side of the fan) to release it from its locking position as shown in the picture below.
2. Once the front chassis fan is loosened, you can pull it out.

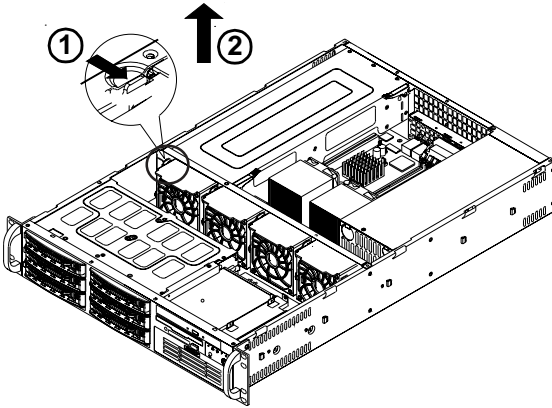

### **Procedures: Installing the Air Shroud**

1. Locate the two holes in the chassis and two hooks in the air shroud as shown in the picture below.
2. Insert the two air shroud hooks into the two holes in the chassis.
3. Gently push the air shroud into the chassis to secure it.

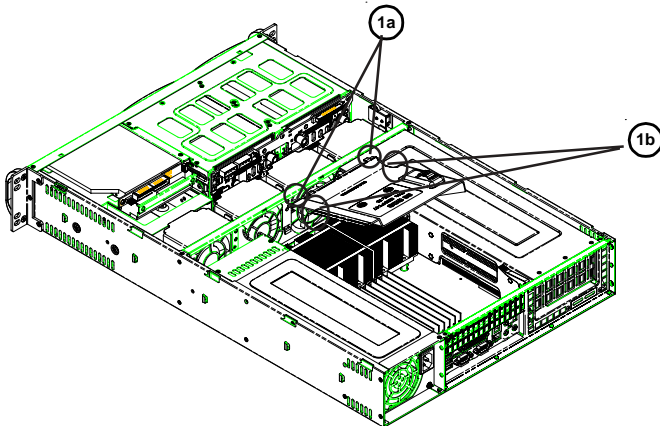

**F. Accessing the Redundant Power Supply (\*For the 8S3S-R550RC/R500LP, 823T-R500RC, 823i-R500RC)**

**(Caution: Unplug the Power Cord before removing the Power Supply!!)**

**Procedures**

1. Locate the release tab on the left side of the power supply.
2. Push the release tab to the right to release the power supply from its locking position as shown below.

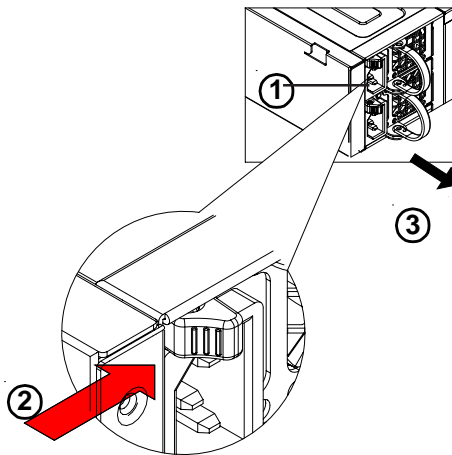

3. Once the power supply module is released from its locking position, remove it from the chassis.



**Warning:** *Do not open the casing of a power supply. Power supplies can only be accessed and serviced by a qualified technician from the manufacturer.*

## G. Installing the Motherboard



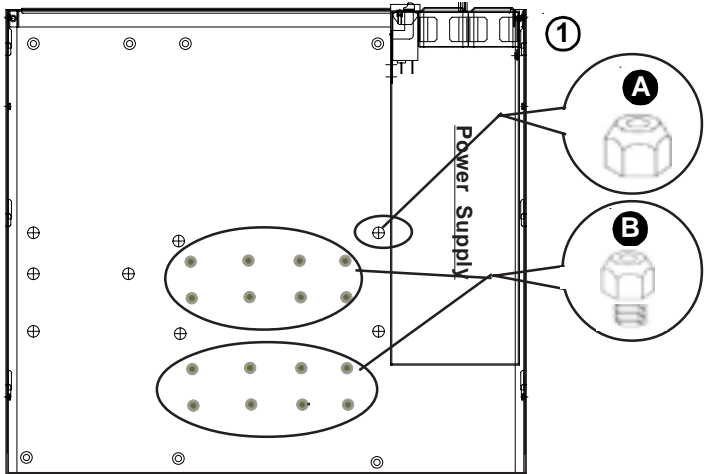

Be sure to disconnect the power supply before accessing or installing the motherboard into the chassis. To install the motherboard to the chassis, first, you will need to install the correct type of standoffs at the proper locations before installing the motherboard into the chassis. (Refer to Chapter 1 for Safety Guidelines.)

### Procedures

1. Lay the chassis on a flat surface. Locate the mounting holes on the motherboard and locate the corresponding mounting holes on the chassis.



2. On the chassis, install standoffs in the mounting holes that are corresponding to the mounting holes on the motherboard.
3. Lay the motherboard on the standoffs and secure it to the chassis with the correct types of screws at proper locations.
4. Secure the CPU(s) and heatsink(s) to the motherboard and the chassis as needed.

(For , please use Type . For , please use Type .)



**Warning:** For proper cooling, please make sure that all the chassis covers are installed before you operate the system. Out of warranty damage can occur if this rule is not strictly followed.



## H. Installing Chassis Rails

Please make sure that the chassis covers and chassis rails are installed on the chassis before you install the chassis into the rack.



To avoid personal injury and property damage, please carefully follow all the safety steps listed below.

### Before installing the Chassis rails:

1. Enclose the chassis with chassis covers.
2. Unplug the AC power cord(s).
3. Remove all external devices and connectors.

### Procedures to Install Chassis Rails

1. Included in the shipping package are a pair of rail assemblies. In each rail assembly, locate the inner rail and the outer rail.
2. Press the locking tab to release the inner rail from its locking position and pull out the inner rail from the rail assembly. (\*The inner rails are to be attached to the chassis and the outer rails are to be installed in the rack.)

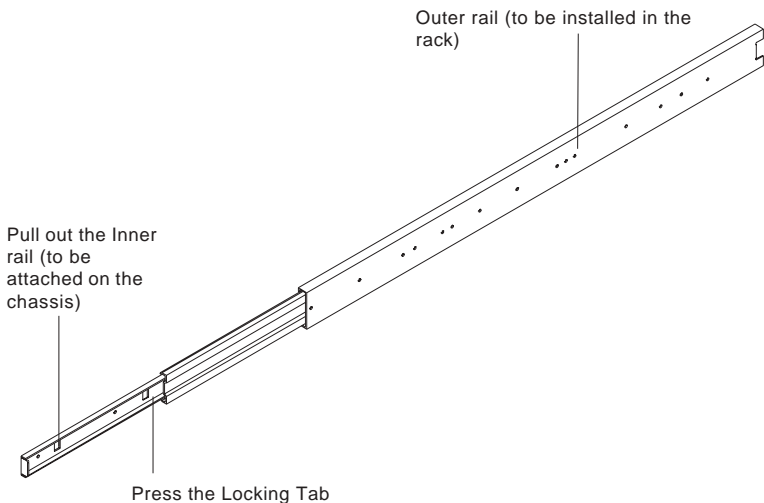

3. Locate the five rail hooks on each side of the chassis and the five corresponding holes on each of the inner rail.
4. Align the five holes on the rail against the corresponding hooks on the chassis. Once aligned, attach the inner rail to the chassis by pressing the holes into the corresponding hooks.
5. Once the rail is placed on the chassis, pull the rail forward until you hear the click.
6. Secure the rail to the chassis with a Type I screw (Refer to Page 2-1 for the Type I screw.) Repeat the above steps to install other rail on the chassis.

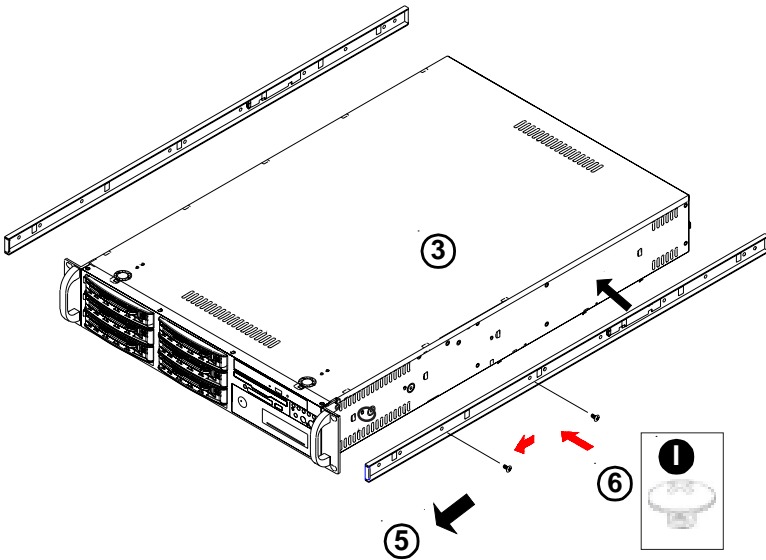

## I. Rack Installation

After you have installed the inner rails on the chassis, you are ready to install the outer rails of rail assemblies to the rack.

(\* The rails are designed to fit in the racks with the depth of 28" to 33".)

### Procedures

1. In the package, locate a pair of front (-short) and rear (-long) brackets. Please note that the brackets are marked with Up/Front Arrows (-front) and Up/Rear arrows (-rear).
2. Secure the front (-short) bracket (marked with the Up/Front arrows) to the outer rail with two Type I screws.
3. Attach the rear (-long) bracket to the rail unit by sliding the rear rail into the rail unit. Insert the complete rail assembly into the chassis.
4. Measure the depth of your rack and adjust the length of the rail assembly accordingly.
5. Repeat the same steps to install the other rail assembly into the chassis.
6. Secure both outer rail assemblies to the rack with Type J screws and Type K washers.

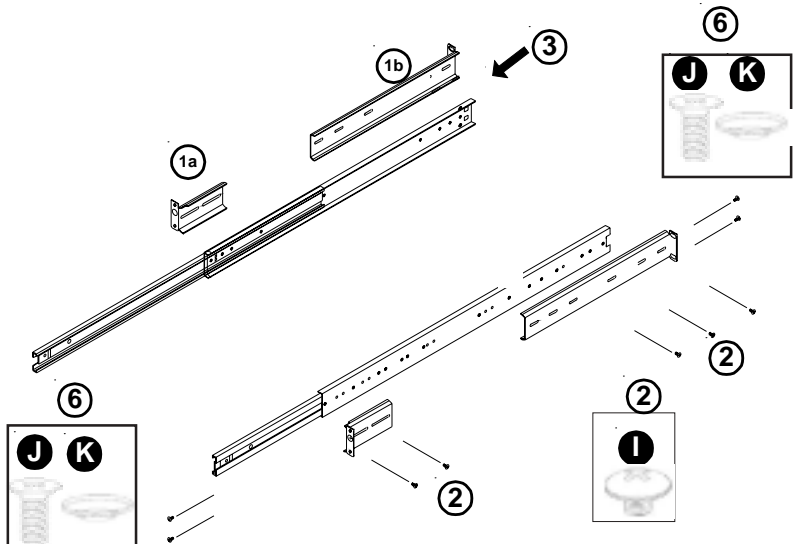

7. Slide the SC823 chassis into the rack **until you hear the click.**

(The SC823 chassis may not slide into the rack smoothly or easily when installed the first time. However, some adjustment to the slide assemblies might be needed for easy installation.)

8. You will need to release the safety tabs on both sides of the chassis in order to completely remove the chassis out of the rack.

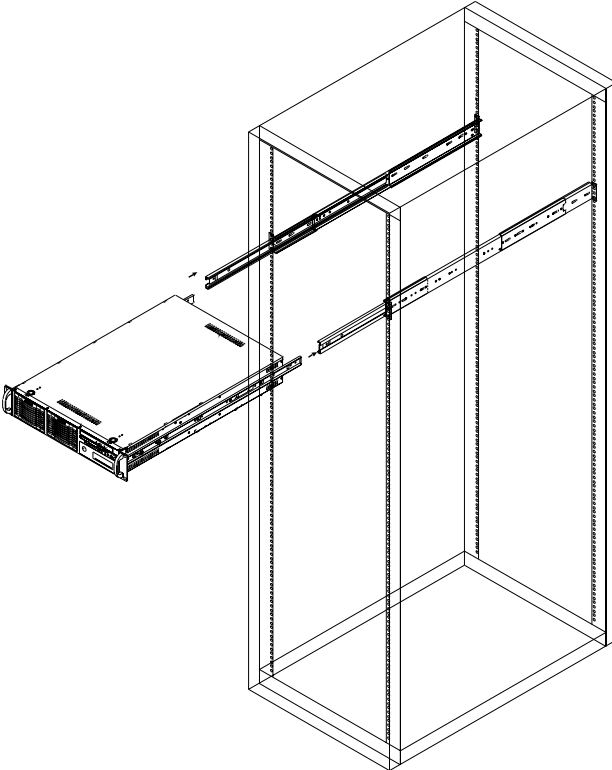

## Free Manuals Download Website

<http://myh66.com>

<http://usermanuals.us>

<http://www.somanuals.com>

<http://www.4manuals.cc>

<http://www.manual-lib.com>

<http://www.404manual.com>

<http://www.luxmanual.com>

<http://aubethermostatmanual.com>

Golf course search by state

<http://golfingnear.com>

Email search by domain

<http://emailbydomain.com>

Auto manuals search

<http://auto.somanuals.com>

TV manuals search

<http://tv.somanuals.com>