

**MODELS 315I AND 315IP ICE MAKER**

## **INSTALLATION & OPERATION**





## CONTENTS

<b>Models 315I and 315IP Installation</b>	<b>4</b>
<b>Installation Checklist</b>	<b>13</b>
<b>Models 315I and 315IP Features</b>	<b>14</b>
<b>Models 315I and 315IP Operation</b>	<b>15</b>
<b>Troubleshooting Guide</b>	<b>20</b>
<b>Service Information</b>	<b>22</b>
<b>Sub-Zero Warranty</b>	<b>23</b>

*Features and specifications indicated herein and on the website are subject to change at any time without notice. Check our website, [subzero.com](http://subzero.com), for the most up-to-date specifications.*

As you follow these instructions, you will notice **WARNING** and **CAUTION** symbols. This blocked information is important for the safe and efficient installation of Sub-Zero equipment. There are two types of potential hazards that may occur during installation.

### **⚠ CAUTION**

signals a situation where minor injury or product damage may occur if you do not follow instructions.

### **⚠ WARNING**

states a hazard that may cause serious injury or death if precautions are not followed.

Another footnote we would like to identify is **IMPORTANT NOTE**: This highlights information that is especially relevant to a problem-free installation.



## THANK YOU

Congratulations on the purchase of your Sub-Zero Model 315I ice maker (Model 315IP with drain pump). This restaurant-type ice maker is designed for home use. It produces the same high quality clear ice that you would expect from Sub-Zero.

The importance of the installation of the Model 315I(P) ice maker cannot be overemphasized. Installation should be done by a qualified installer.

Before you begin the installation process, it is recommended that you read the entire installation instructions. There are key details that you should take special care to observe during the installation. By reading these instructions carefully, you will make the installation process easier, problem-free and, most importantly, safe.

Any questions or problems about the installation should be directed to your Sub-Zero dealer or Sub-Zero Customer Service at 800-222-7820. You can also visit our website at [subzero.com](http://subzero.com).

The Model 315I(P) ice maker is protected by a warranty that is one of the finest in the industry. Take a moment to read the warranty statement on page 23 and refer to it should service become necessary.

The Operation information in this book will answer most of your questions about the features, operation and maintenance of your ice maker. If you have questions that are not addressed here, call Sub-Zero Customer Service at 800-222-7820 or visit our website at [subzero.com](http://subzero.com).

**IMPORTANT NOTE:** Your Sub-Zero ice maker is designed and manufactured with the highest regard for safety and performance. It meets or exceeds the standards of UL and CUL. Sub-Zero assumes no liability or responsibility of any kind for products manufactured by Sub-Zero that have been altered in any way, including the use of any parts and/or other components not specifically approved by Sub-Zero. Sub-Zero reserves the right to make design changes and/or improvements at any time. Specifications and designs are subject to change without notice.

## CONTACT INFORMATION

**Sub-Zero  
Customer Service:**  
800-222-7820

**Website:**  
[subzero.com](http://subzero.com)



## ICE MAKER REQUIREMENTS

To properly make and store ice, the Model 315I(P) requires access to air, potable water, 115 V AC electrical supply and a drain. The ice maker must be installed indoors, in a controlled environment.

### AIR SUPPLY

The ice maker uses a fan to take in room air at the front of the ice maker through the right side of the kickplate/grille. It discharges warm air out the left side of the kickplate/grille. Anything placed in front of the kickplate/grille will restrict air flow and cause a decrease in performance and efficiency. The minimum air temperature the ice maker will operate in is 50°F (10°C), and the maximum is 100°F (40°C).

### WATER SUPPLY

The ice maker requires a continuous supply of potable water at no less than 20 psi (1.4 bar) of flowing pressure. Static water pressure should not exceed 80 psi (5.5 bar). The minimum water temperature the ice maker will operate in is 40°F (5°C), and the maximum is 100°F (40°C).

### WATER QUALITY

There is no such thing as “pure” water. All water, including potable water supplied by municipalities, contains some impurities. Water absorbs impurities from the air as rain and as it flows through the ground. Some of the impurities are solid particles; these are known as suspended solids and a fine particle filter will remove them. Other impurities are chemically bonded to the water molecules and cannot be filtered out; these are called dissolved solids.

Ice made by the Model 315I(P) will have a lower mineral content than the water from which it was formed.

Water with fewer impurities will freeze more quickly. This occurs because impurities cause the water temperature to rise. This concentrates most of the impurities in the ice maker water reservoir where they may form hard deposits known as scale. The Model 315I(P) dilutes the concentration of minerals by over-filling the reservoir during the harvest cycle (with the excess water flowing down the drain). About three quarts of water flow into the unit each cycle. About one quart of that rinses the reservoir and goes down the drain.

Some impurities will inevitably remain and will stick to the inner parts of the ice maker resulting in malformed ice cubes. Built up mineral scale can shorten the life of your ice maker.

To keep the ice maker operating properly, these impurities or minerals will have to be regularly dissolved by an acid cleaning using Sub-Zero ice maker cleaner. Directions for cleaning the Ice Making System are on page 18.

In general, it is always a good idea to filter the water. A water filter, if it is the proper type, can remove taste and odors as well as particles. Some methods of water treatment for dissolved solids include reverse osmosis and polyphosphate feeders. A reverse osmosis system should include post treatment to satisfy the reverse osmosis water’s “aggressiveness”. Deionized water is not recommended.

Because water softeners exchange one mineral for another, Sub-Zero does not recommend their use for ice makers. Where water is very hard, softened water may result in white, mushy cubes that stick together.

If there are questions about the purity of your water, contact a local point-of-use water specialist in your area for recommendations on water treatment.



## INSTALLATION SPECIFICATIONS

### AREA REQUIREMENTS

Before moving the ice maker in place, be sure the finished opening dimensions, electrical and plumbing locations are accurate. Refer to the Installation Specifications illustrations on pages 7–8. The illustrations below provide overall dimensions for Models 315I and 315IP.

Be sure your plumber, electrician and cabinet installer have this information before finishing work is completed.

Model 315I is a gravity drain model that requires a drain tube that is pitched down from the outlet at the back of the unit to the sanitary sewer connection. Model 315IP has a built in drain pump that will pump water up to a drain point, such as a nearby sink. Refer to specifications on pages 7–8.

**IMPORTANT NOTE:** If the ice maker is installed in a corner, the door swing may be limited due to handle contact with the wall or cabinet face.

**IMPORTANT NOTE:** The floor under the ice maker must be at the same level as the surrounding finished floor.

**IMPORTANT NOTE:** When you move the unit using a hand truck or dolly, position the dolly on the side of the unit and secure the door so it does not open while transporting the unit.

#### ⚠ CAUTION

**Any finished flooring should be protected with appropriate material to avoid any damage from moving the unit.**

## OVERALL DIMENSIONS

*Models 315I and 315IP*

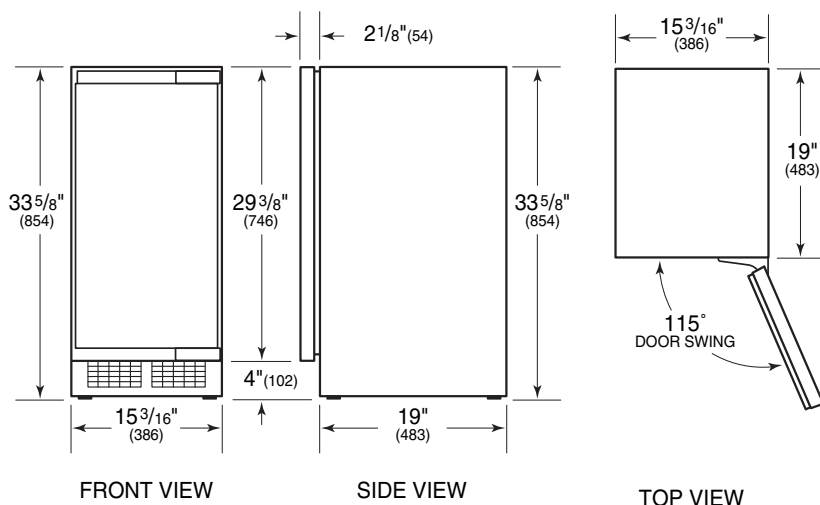

### MODELS 315I AND 315IP

Overall Width	15 <sup>3</sup> / <sub>16</sub> " (386)
Overall Height	33 <sup>5</sup> / <sub>8</sub> " (854)
Overall Depth	24" (610)
Minimum Door Clearance	15 <sup>1</sup> / <sub>4</sub> " (387)
Rough Opening Width	15 <sup>1</sup> / <sub>4</sub> " (387)
Rough Opening Height	34 <sup>1</sup> / <sub>2</sub> " (876)
Minimum Height Required (levelers in)	33 <sup>3</sup> / <sub>4</sub> " (857)
Rough Opening Depth	24" (610)

*Dimensions may vary  $\pm 1/8"$  (3).*

*Dimensions may vary  $\pm 1/8"$  (3).*

Dimensions in parentheses are in millimeters unless otherwise specified.



**ELECTRICAL** REQUIREMENTS

A 115 V AC, 60 Hz, 15 amp circuit breaker and electrical supply are required. A separate circuit is required for each unit.

The Model 315I(P) is equipped with a power supply cord with a 3-prong grounding plug, which must be plugged into a mating 3-prong grounding-type electrical outlet.

Follow the National Electrical Code and local codes and ordinances when installing the receptacle. For location of the electrical supply, refer to the Installation Specifications illustrations on pages 7–8.

**IMPORTANT NOTE:** A ground fault circuit interrupter (GFCI) is not recommended and may cause interruption of operation.

**⚠ WARNING**

**Do not use an extension cord or two-prong adapter. Electrical ground is required on this appliance. Do not remove the power supply cord ground prong.**

**⚠ WARNING**

**Shut off the power to the electrical outlet.**

**PLUMBING** REQUIREMENTS

Rough in the water supply line. Connect a 1/4" OD copper line to the house supply. Be sure to use an easily accessible shut-off valve between the supply and the unit. This shut-off valve should not be installed behind the unit. Do not use "self-piercing" valves. A saddle valve (part #4-20-088-0) is available from your Sub-Zero dealer. A line filter is required when the water supply has a high mineral content. The water supply must maintain 20 psi (1.4 bar) to 80 psi (5.5 bar) of water pressure.

The water supply and drain should be roughed in and ready at the point of installation. An electrical outlet directly behind the ice maker will make the installation easier. All electrical, water and drain connections must conform to local codes. For location of the water supply, refer to the Installation Specifications illustrations on pages 7–8.

**IMPORTANT NOTE:** Although the Model 315I(P) has been designed to be serviced in place, in some cases it may be necessary to pull the unit out for service. For that reason do not restrict access to the unit at the front, top and bottom.

If a floor is to be installed after the ice maker, shims the thickness of the floor should be installed under the Model 315I(P) to keep the ice maker level with the floor. Also, allow 1/8" (3) clearance on each side of the unit for protruding screw heads.

**Installations on a slab:** Use a Model 315IP, with built-in drain pump and pump the water to the point of drainage. Drain pump models will pump one story high.

**Installations over a crawl space or basement:** Either a gravity drain (Model 315I) or a drain pump (Model 315IP) unit may be used. If there is not enough room behind the ice maker for a drain/waste water receptacle, the drain will have to be below the floor.

**IMPORTANT NOTE:** All plumbing must meet local codes.

**IMPORTANT NOTE**

**You must follow all National Electrical Code regulations. In addition, be aware of local codes and ordinances when installing your services.**

Dimensions in parentheses are in millimeters unless otherwise specified.



**MODEL 315I GRAVITY DRAIN**

The drain and inlet water tubes must be plumbed before connecting to the ice maker. Refer to the illustrations below. All horizontal runs of drain lines must have a 1/4" (6) per 12" (305) fall. An air gap will likely be required between the ice maker drain tube and the drain/waste water receptacle. A stand pipe with a trap below it can be used for the drain/waste water receptacle.

**IMPORTANT NOTE:** Poor drainage will cause a high rate of ice melting in the ice storage bin.

- 1) Place the ice maker in front of the installation opening. Adjust leveling legs to the approximate height.
- 2) Remove the door (with hinges), control knob, control panel, access panel and lower face plate.
- 3) Route the water inlet line (1/4" OD copper tube) from the wall through the ice maker to the front.
- 4) Route the drain line from the wall position through the ice maker. If you have a horizontal run longer than 5' (1.5 m), the drain should be vented at the back of the unit.
- 5) If the electrical outlet for the ice maker is behind the unit, plug in the unit.
- 6) Position the unit in the installation opening.
- 7) Cut the water inlet line to the required length.
- 8) Flush the water line. Place the flare nut on the water line and flare the end of the copper tube.

- 9) Attach the flare nut to the male flare on the inlet water valve.
- 10) Cut the drain tube to the required length.
- 11) Connect the 5/8" drain tube to the storage bin drain fitting at the bottom of the bin. Secure with hose clamps. Be sure that the drain tube is pushed up well past the barbs on the drain fitting. If needed to ease installation, soak the drain hose in hot water just before connecting to the fitting.
- 12) Turn on the water supply and check for leaks.
- 13) Replace the door (with hinges), control knob, control panel, access panel and lower face plate. Level the unit as needed.

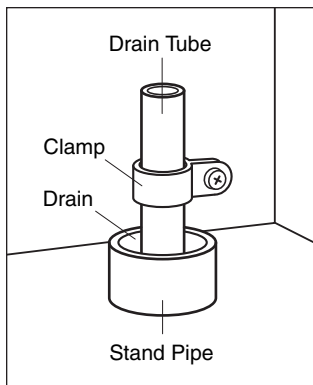

**Drain tube detail**

**INSTALLATION SPECIFICATIONS**

*Model 315I*

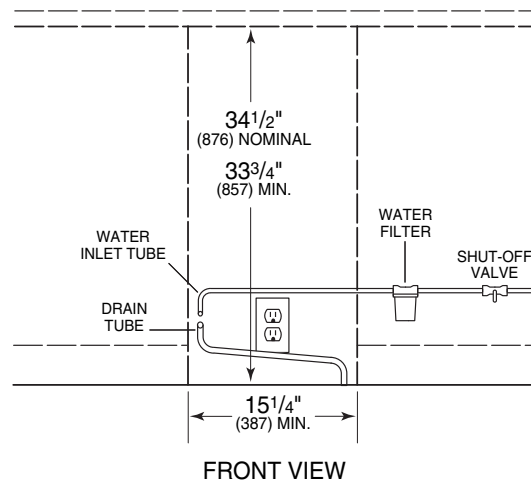
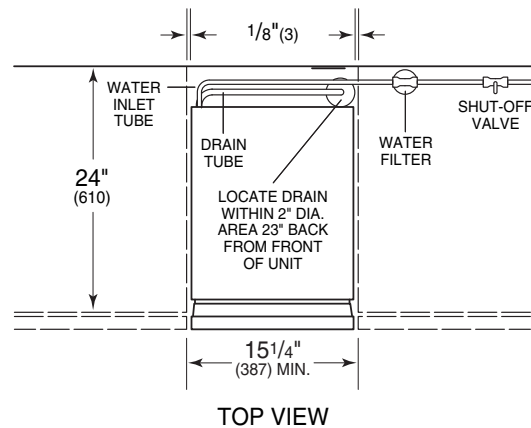



**MODEL 315IP DRAIN PUMP**

- 1) Place the ice maker in front of the installation opening. Adjust leveling legs to the approximate height.
- 2) Remove the control knob, control panel and control access panel.
- 3) Route the water inlet line (1/4" OD copper tube) from the wall through the ice maker to the front.
- 4) Locate the coil of 3/8" ID plastic drain tubing secured to the back of the unit.
- 5) Route the plastic drain tube from the back of the unit to the drain connection point.

**IMPORTANT NOTE:** Often an air gap is required by local codes between the ice maker drain tube and the drain receptacle. Refer to the illustration below.

- 6) If the electrical outlet for the ice maker is behind the unit, plug in the unit.
- 7) Position the unit in the installation opening.
- 8) Cut the water inlet line to the required length.
- 9) Flush the water line. Place the flare nut on the water line and flare the end of the copper tube.
- 10) Attach the flare nut to the male flare on the inlet water valve.
- 11) Turn on the water supply. Make sure that the ice maker is plugged in and the power is on.
- 12) Pour a couple of quarts of water into the ice storage bin; the drain pump should start and water should pump out. Check for leaks.
- 13) Replace the control knob, control panel and control access panel. Level the unit as needed.

**IMPORTANT NOTE:** All plumbing must meet local codes.

Dimensions in parentheses are in millimeters unless otherwise specified.

**DRAIN PUMP KIT**

This ice maker can be ordered with a drain pump (Model 315IP) or without (Model 315I). Models without a pump drain their water by gravity. However, gravity drain models may be converted to pump models through the installation of a drain pump kit.

The parts required for this conversion are available through your Sub-Zero dealer. You can also visit the Locator section of our website, subzero.com, to obtain information on the local parts distributor and/or dealer in your market. Detailed installation instructions are included with the kit.

**Drain pump kit (#A36892020)**  
**Drain pump (#12250321)**

**INSTALLATION SPECIFICATIONS**  
*Model 315IP*

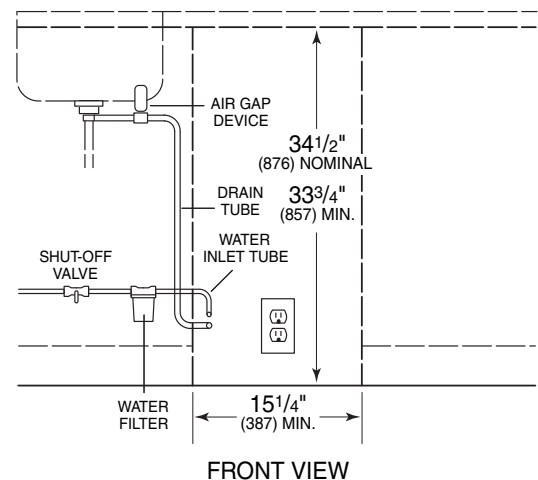
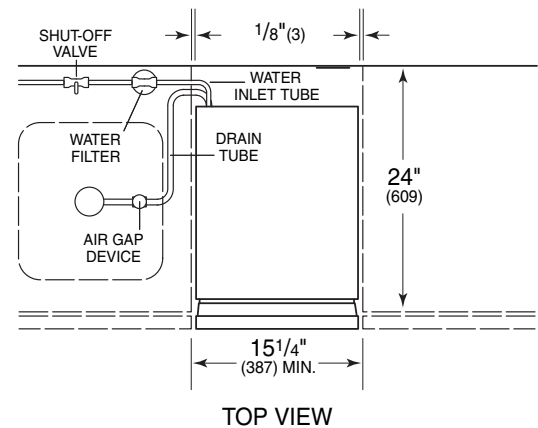

**OPTIONAL COMPONENTS**

Optional installation components are available through your Sub-Zero dealer. You can also visit our website at subzero.com. For installation questions, call Sub-Zero Customer Service at 800-222-7820.





## INSTALLATION

**IMPORTANT NOTE:** Turn on the water supply and check all fittings for leaks. Make sure the electrical harness is attached to the solenoid.

Let your customer know that the ice maker will not fill with water immediately and that the first batch of ice produced should be discarded. Allow 24 to 36 hours for proper ice production.

### LEVELING

Level the Model 315(P) by turning the leveling legs counterclockwise to raise or clockwise to lower.

To assist you in adjusting the front leveling legs up or down, use a standard screwdriver blade and place it in the front leveling leg to turn.

### SECURE THE ICE MAKER

To secure the ice maker, install two #8 x 1/2" flat head screws through each hinge. Refer to the illustration below.

### KICKPLATE/GRILLE INSTALLATION

Once the ice maker is secured, you can install the kickplate/grille. As shown in the illustration below, there is some adjustment to the mounting assembly so this decorative piece can fit flush with the surrounding area.

#### ⚠ CAUTION

**DO NOT cover the kickplate/grille area.**

The unit must be allowed to have ventilation through these fins. The door panel may hang in front of the fins, but a decorative kickplate/grille must not cover the fins.

The kickplate/grille can be painted another color, if you choose. Follow these easy steps:

- Rough up surface to be painted with fine grit sandpaper.
- Wipe with alcohol to ensure it is clean and dry.
- Use an appliance or industrial grade, oil base, high gloss enamel paint.

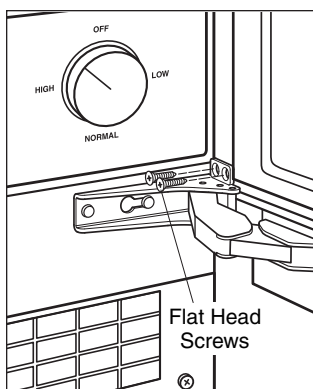

**Securing the ice maker**

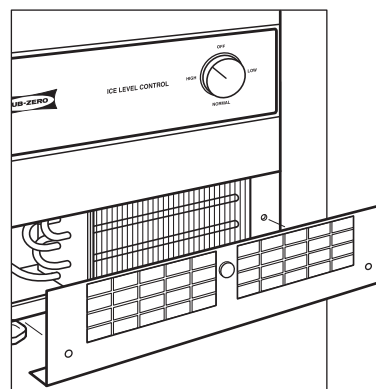

**Kickplate/grille installation**



## INSTALLATION

### SIDE PANELS

With Model 315I(P), you must securely fasten the side panels to the adjacent cabinets and floor.

Panels should be fastened to the floor and walls using 'L' brackets (hardware not provided). To help you move the unit into place, rout out an area in the floor so the 'L' bracket will sit flush with the floor level. Brackets and screws are provided for mounting the unit to adjoining cabinets and side panels.

### REVERSE THE DOOR SWING

The hinged side of the door may be reversed to the other side if desired.

The Model 315I(P) is shipped with the door hinged at the right. The door and hinges are designed for placing the hinges on either the right or the left side of the unit. Moving the hinges to the left in the pre-drilled holes, allows the door to pivot from the left side. Refer to the illustrations below.

**IMPORTANT NOTE:** The plastic molding which covers the top area of the door, packaged with the ice maker, is required for this procedure.

- 1) Remove the hinge cover.
- 2) Remove the door by removing the four screws that secure the door to the door hinges.
- 3) Remove the door hinges by removing the four screws that secure them to the unit.
- 4) Remove the four screws from the opposite hinge side (or left-hand hinge mounting holes) and reposition into the right-hand hinge mounting holes.
- 5) Install the hinges using the left-hand cabinet mounting holes.
- 6) Install the door using the left-hand door mounting holes.
- 7) Remove the two screws which secure the upper door panel mounting bracket.
- 8) Install the upper door panel mounting bracket using the left-hand mounting holes.
- 9) Install the left-hand door hinge cover with the original screws.
- 10) Check the operation of the door by opening and closing it.

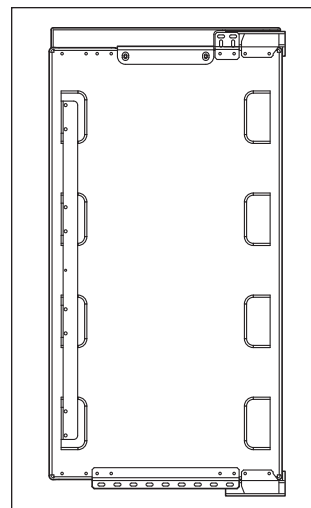

Right-hand door swing

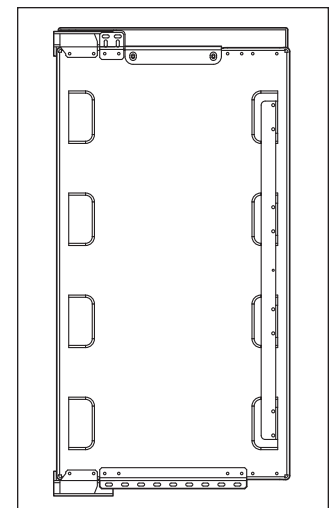

Left-hand door swing



## INSTALLATION

### DOOR PANEL INSTALLATION

You should be sure of the door panel size and placement before proceeding with the installation. If you have questions, contact your Sub-Zero dealer or cabinet supplier. Instructions regarding sizing of the door panel are provided in the Sub-Zero Design Guide.

For door handle hardware, a D-style pull centered on the edge opposite the door hinge side is recommended. Screw heads may have to be countersunk to ensure that the hardware does not interfere with the panel fitting flush with the unit door.

#### MODELS 315I AND 315IP

Door Panel Width – 1/8" (3) reveal	15" (381)
Door Panel Height – 1/8" (3) reveal 4" (102) toe space	30 3/8" (772)
Door Panel Thickness	5/8" (16) min
Door Panel Weight	15 lbs (6.8 kg) max

*Dimensions may vary ± 1/8" (3).*

Remove the handle side bracket attached to the front of the door and set aside.

Place the door panel lying face down on a protected surface to ensure the front is not scratched or damaged.

Position the plastic template provided flush with the upper edge of the door. Be sure you are following the exact location for the RH or LH door position. Refer to the illustration below.

**IMPORTANT NOTE:** Remember you are viewing the door panel from the back side in the illustration. The overall size of the panel shown is the minimum size necessary to cover the door of the unit. The exact measurements of your door panel may vary depending on the particular installation you are following.

Once you have located the proper position for the hardware, mark the holes, remove template, and drill pilot holes for mounting of the hardware. We recommend starting the first few holes, positioning the hardware, drilling remaining pilot holes, and securing the mounting brackets with the #8 x 1/2" screws. Refer to the illustrations below.

### PANEL DESIGN

Additional panel design information can be found in the Sub-Zero Design Guide. Check our website at [subzero.com](http://subzero.com).

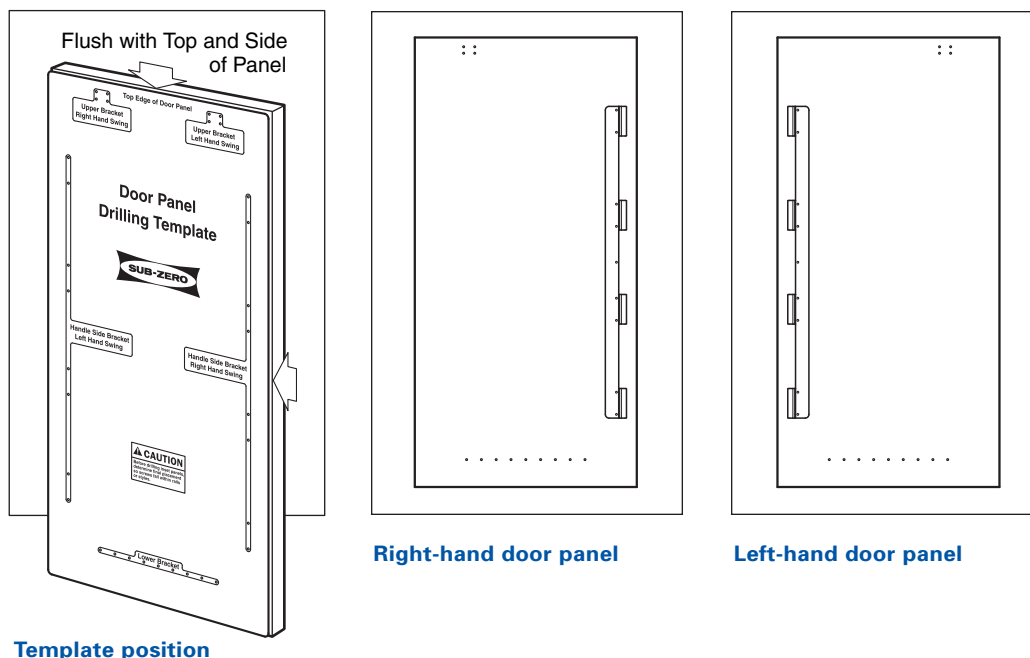

Template position

Right-hand door panel

Left-hand door panel



## INSTALLATION

### ⚠ CAUTION

Exercise caution when drilling holes for mounting hardware. This is especially critical with inset panels.

Install the door panel by engaging the tabbed bracket to the door first and then sliding the hinge side hardware over the positioning screws. You will have a 1/4" inch adjustment, up and down, side to side, with this hardware.

Once you have the door in place, attach the remaining #8 x 1/2" screws to the hinge side mounting bracket and install decorative caps.

### ⚠ CAUTION

If the reveal on the hinge side of the door panel is less than 1/4", and the panel has a square corner, severe finger pinching or damage to the unit may occur.

## 90-DEGREE DOOR STOP

Model 315I(P) has a 90-degree door stop. Follow these steps for installation:

- 1) Open the door approximately 80 degrees.
- 2) Insert the stop pin into the bottom door hinge (pin enters from the top). The pin must be inserted until the head has made contact with the hinge body. Refer to the illustration below.
- 3) Insert the stop pin into the top door hinge (pin enters from the bottom).
- 4) Check for proper operation.

## HINGE COVER INSTALLATION

**IMPORTANT NOTE:** Install the hinge covers after installation of the ice maker is complete. The 90-degree door stop must be installed prior to installing the hinge covers.

- 1) Remove the backing paper of the adhesive pads and bond to the hinge.
- 2) Install center covers (magnets will secure these covers). Refer to the illustration below.

**IMPORTANT NOTE:** Hinges must be free of dirt or grease before applying covers.

**IMPORTANT NOTE:** It will be necessary to remove the knock-out in the hinge cover when the 90-degree door stop is used.

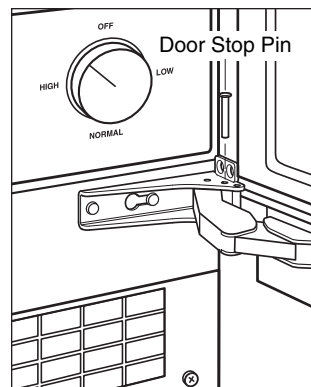

90-degree door stop

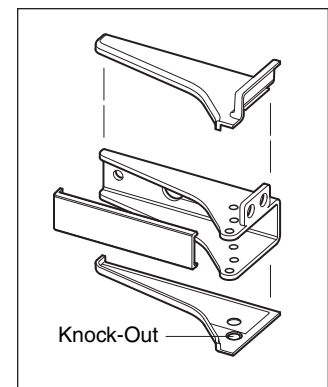

Hinge cover installation



## INSTALLATION CHECKLIST

**IMPORTANT NOTE:** To ensure a safe and proper installation, the following checklist should be completed by the installer to ensure that no part of the installation has been overlooked.

Any questions or problems about the installation should be directed to your Sub-Zero dealer or Sub-Zero Customer Service at 800-222-7820. You can also visit our website at [subzero.com](http://subzero.com).

- Is the unit operating? If not, is the unit plugged in? Check to see if the unit is operating before you install.
- Has the unit been properly uncrated, and have all packing materials and tape been removed from inside the unit?
- Have the installation instructions been followed?
- Has the unit been leveled?
- Is the kickplate/grille installed?
- If applicable, is the door panel installed properly?
- Does the customer understand the unit's operation?
- Have any installation or service problems been noted on the product registration card? Instruct the owner to register the product.

### ⚠ WARNING

**If you are storing or disposing of your old refrigerator or freezer, please do it safely. Remove the doors or tightly secure the doors closed. Child entrapment accidents can be tragic.**

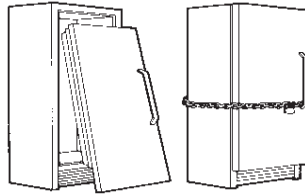

## CONTACT INFORMATION

**Sub-Zero  
Customer Service:  
800-222-7820**

**Website:  
[subzero.com](http://subzero.com)**



**MODELS 315I AND 315IP** FEATURES

- Undercounter ice maker
- Model 315I has a gravity drain, while Model 315IP has a built-in pump to allow water to drain into adjacent sink
- 24" (610) depth-true design for a complete integrated look
- Door accepts custom panels
- Automatic ice maker provides high-quality, clear ice
- Ice storage bin capacity of up to 26 lbs (12 kg)
- Automatic defrost
- Reversible door swing
- Front venting with removable kickplate/grille allows unit to be serviced from the front
- Solid core door with magnetic gasket and door closer
- UL approved for US and Canada
- Two, five and twelve year residential warranty – exclusions apply, see warranty at the end of this guide

WARRANTY

Sub-Zero products are covered by a two, five and twelve year residential warranty (exclusions apply). See warranty details at the end of this guide.

**MODEL 315I**

*Ice Maker*

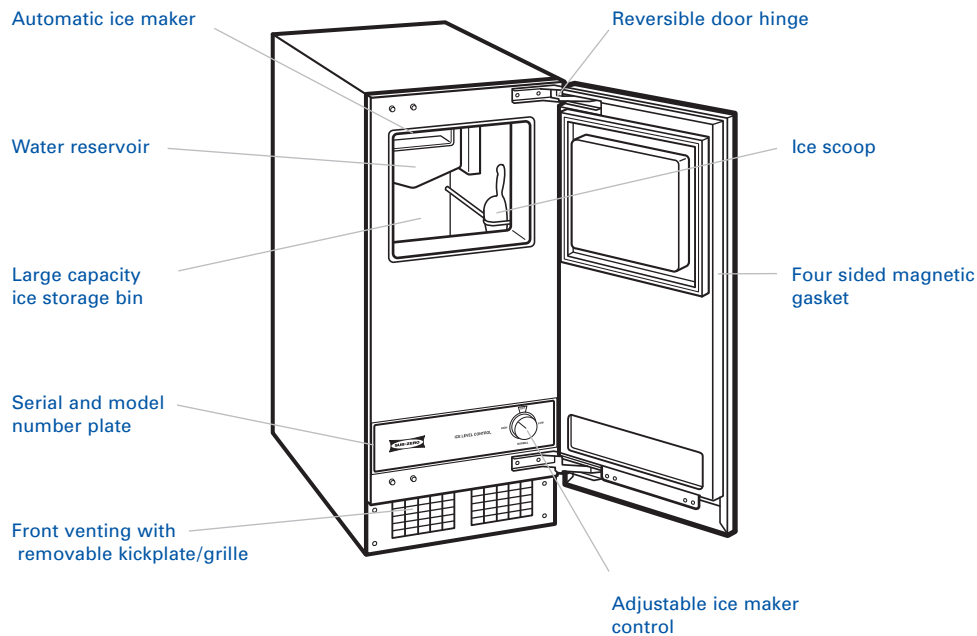



## ICE MAKER OPERATION

### INITIAL START-UP

- 1) Remove the control box cover.
- 2) Rotate timer shaft clockwise until the cam is in the harvest position (switch button out).
- 3) Turn on the water supply.
- 4) With unit plugged in, rotate the ice maker control knob to the ON position.
- 5) Allow the ice maker to operate for one hour, and check the size of the cubes; if they are not correct, adjust as recommended on page 18.
- 6) After the cubes are confirmed to be the correct size, replace all panels.

### USING YOUR ICE MAKER

The ice maker is extremely simple to use; by turning the ice maker control knob to the ON position. The Model 315I(P) will automatically begin to produce ice and will continue to do so until the ice storage bin is full.

Use the scoop to remove ice and place the ice scoop in the holder provided (do not leave the scoop on the ice, as it will gradually disappear into the ice).

The Model 315I(P) will release a batch of eight ice cubes about every 30 minutes. At the same time the cubes fall into the ice storage bin, water will be entering the ice maker and draining out.

**IMPORTANT NOTE:** Do not store anything in the ice storage bin other than ice; items like wine or beer bottles are not only unsanitary, but labels may also slip off and plug the drain.

### ICE CUBES

The ice cubes are tapered cylinders about 1<sup>1</sup>/<sub>4</sub>" (32) in diameter at the widest end; taper down to 1" (25) wide at the top; and are 1<sup>1</sup>/<sub>8</sub>" (29) high. When the ice maker is adjusted properly, there should be a 1/4" (6) indent in the base of the cube. The ice will appear wet when fresh and may also develop frost on the outside and look cloudy. This is normal. The frost will disappear when liquid is poured over the ice.

### ICE STORAGE BIN

All restaurant-type ice makers, such as the Model 315I(P), operate on this principal: The ice storage bin is not refrigerated; instead it's heavily insulated, much like a picnic cooler or ice chest. If the ice storage bin were to be refrigerated, the ice would freeze together into one very large cluster of ice and would begin to evaporate. This would yield ice that is very poor in quality and difficult to remove from the ice maker.

The Model 315I(P) will continue to operate until ice builds up high enough to contact thermostat sensor tube in the ice storage bin; then it will shut off. Models with a drain pump will occasionally pump out melt water when the ice maker is off. The pump will only be on for a few seconds.

### RUN TIME

The amount of time the Model 315I(P) will run to replace melted ice is about two hours per day. The amount of time the ice maker will run to replace ice removed is dependent upon how much ice is removed, how clean the ice maker is, the surrounding air temperature and the temperature of the water supplied to the ice maker. An empty ice maker will usually take about 24–36 hours to refill.



## ICE PRODUCTION

Ice production has two distinct cycles: freeze and harvest. One freeze cycle and one harvest cycle will yield a batch of eight ice cubes.

The freeze cycle occurs when water is sprayed against the freezing surface. The harvest cycle occurs when the ice is released and water enters the ice maker. A complete cycle takes about 30 minutes.

### FREEZE CYCLE

During the freeze cycle the compressor is pumping refrigerant, the fan motor is blowing air, and the water pump is circulating water. As the refrigerated surface absorbs heat from the water sprayed against it, that heat is moved to the area where the fan is blowing air. The heat is transferred to the air, and the warmed up air is discharged from the ice maker. At the same time, ice is forming on the refrigerated surface (located at the upper back of the ice maker). When the refrigerated surface gets cold enough, the ice maker's timer will begin to turn. When it turns far enough, it will stop the freeze cycle and begin the harvest.

### HARVEST CYCLE

During the harvest cycle the compressor is still operating, but the spray pump and fan motor have stopped. Two other components have been energized: the hot gas valve and the inlet water valve. These two valves open and warm up the freezing surface, allowing the cubes to fall into the ice storage bin. The timer is still turning, and when it gets to the end of the harvest cycle, the freeze cycle will restart.

### HOW THE ICE MAKER USES WATER

The ice maker begins with a fixed charge of water that is contained in the reservoir. As the water is sprayed against the freezing surface, the part of water that does not contain mineral impurities will freeze and stick to the ice cup molds. The water containing impurities falls back into the reservoir. Gradually, during the freezing portion of the ice making cycle, the water in the reservoir will become highly concentrated with mineral impurities.

During the harvest cycle fresh water flows into the ice maker to dilute the reservoir water and to rinse the concentrated minerals down the drain.





## CLEANING

Make sure that the outside of the unit and door, ice storage bin, condenser, ice making system and ice scoop are kept clean.

Never allow the ice maker to operate without regular cleaning. The ice maker will last longer if it is kept clean. Regular cleaning should be done at least once per year, and preferably twice. Some water conditions will dictate more frequent cleaning of the ice making system and some carpets or pets will dictate more frequent cleaning of the condenser.

## EXTERIOR CLEANING

Wipe off any spills on the surface of the door and handle as they occur. If anything spilled on the door or gasket dries onto the surface, wash with soap and warm water to remove. Always use a nonabrasive cloth or pad.

To clean the exterior of a stainless steel model, use a soft, nonabrasive stainless steel cleaner like Signature Polish (see side note) and apply with a soft 100% lint-free cloth.

### ⚠ CAUTION

**For maintenance and cleaning, it is recommended that the circuit breaker to the unit or the on/off control be shut off.**

## CLEANING THE ICE STORAGE BIN

The ice storage bin should be sanitized occasionally. It is usually convenient to sanitize the bin after the ice making system has been cleaned, and the ice storage bin is empty.

A sanitizing solution can be made of one ounce of household bleach and two gallons of hot 95°F–115°F (35°C–45°C) water. Use a clean cloth and wipe the interior of the ice storage bin with the sanitizing solution; pour some of the solution down the drain and allow it to air dry.

SIGNATURE  
POLISH

**Signature Polish is available from Signature Limited Laboratory, P. O. Box 13436, Dayton, Ohio 45413-0436, or call 877-376-5474 (toll free).**

## CLEANING THE CONDENSER

The condenser should be vacuumed two to three times per year to remove any lint that may have been drawn into the condenser. To access the condenser, use a phillips head screw driver to remove the kickplate/grille. Then, using a soft bristle brush, vacuum to remove dust and lint from the condenser. Refer to the illustration below for location of the condenser.

**IMPORTANT NOTE:** To avoid bending the condenser fins, be sure to vacuum in the direction of the fins (up and down).

### ⚠ CAUTION

**Failure to clean the condenser could result in temperature loss or mechanical failure or damage.**

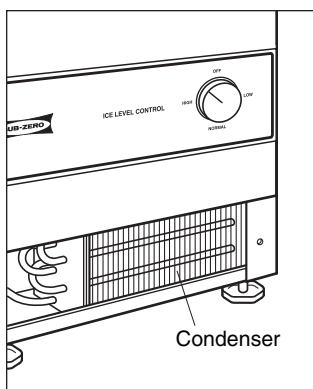

**Condenser location**



ICE MAKER **CLEANING**

**CLEANING THE ICE MAKING SYSTEM**

- 1) Open the door and turn the ice maker control knob to OFF. Refer to the illustration on page 19 for location of the control knob.
- 2) Scoop out all of the ice; either discard it or save it in a ice chest or cooler.
- 3) Pour four ounces of Sub-Zero ice maker cleaner into the ice maker reservoir (see side note).
- 4) Turn the ice maker control to ON.
- 5) Allow the ice maker to operate for about two hours.
- 6) Pour hot water 95°F–115°F (35°C–45°C) into the ice storage bin to melt the ice that has formed. That ice will likely be white and frosty looking.
- 7) Clean the ice storage bin liner of mineral scale by mixing some ice maker cleaner and hot water, using that solution to scrub the scale off of the liner.
- 8) Rinse the liner with hot water.
- 9) Sanitize the ice storage bin interior.
- 10) Replace the ice removed in step 2. The ice scoop should be washed regularly; wash it just like any other food container.

**▲ WARNING**

**Sub-Zero ice maker cleaner contains acids. These compounds may cause burns.**

**If swallowed, DO NOT induce vomiting. Give large amounts of water or milk. Call a physician immediately. In case of skin contact, flush with water. Keep out of the reach of children.**

ICE MAKER  
CLEANER

**Sub-Zero ice maker cleaner (8 oz. bottle) is available from your Sub-Zero dealer. Ask for part #19034306.**

ICE MAKER **MAINTENANCE**

**WINTERIZING**

- 1) Clean the ice making system.
- 2) Turn off the water supply.
- 3) Drain the water reservoir. Remove the pump hose.
- 4) Disconnect the incoming water line at the inlet water valve.
- 5) Remove control box cover and turn the timer into the harvest cycle.
- 6) With the ice maker operating, blow air through the inlet water valve; a tire pump could do the job.
- 7) Drain pump models should have about one-half gallon of RV antifreeze (propylene glycol) poured into the ice storage bin drain.

**IMPORTANT NOTE: DO NOT** use automotive antifreeze.

- 8) Replace control box cover. Turn the ice maker OFF and unplug the unit.

To use the ice maker after winterizing, reconnect the pump hose and water line. Repeat the initial start-up steps outlined on page 15.

ICE MAKER **ADJUSTMENTS**

There are three items that may be adjusted: cube size, storage bin ice level and harvest time.

**IMPORTANT NOTE:** Cube size and harvest time adjustments should only be done by a Sub-Zero authorized service center technician.

**CUBE SIZE ADJUSTMENT**

The cube size control should only be adjusted to bring the ice cubes to the correct shape; the overall size cannot be adjusted. Try to adjust the cube size control when the ice maker is in the harvest cycle, or in the first ten minutes of the freeze cycle.



- 1) Open the door and remove the control box cover.
- 2) Locate the cube size adjustment screw shown in the illustration below. To make fuller cubes, turn the screw clockwise about  $\frac{1}{4}$  turn. This will make the freezing cycle longer.
- 3) To shorten the freezing cycle and make cubes that are not as full, turn the adjustment screw  $\frac{1}{4}$  turn counterclockwise.
- 4) After the next freezing cycle, the cubes should have responded to the adjustment; if another adjustment is required, do it early in the freeze cycle.

#### STORAGE BIN LEVEL ADJUSTMENT

When the ice maker shuts off, the ice level in the storage bin should be even with the metal tube inside the bin. If the ice in the storage bin is too high or too low, turn the ice maker control knob to adjust the ice storage bin thermostat. Refer to the illustration below.

To lower the ice level, turn the knob counterclockwise. To increase the ice level, turn the knob clockwise. Usually a  $\frac{1}{8}$  turn will be enough for either adjustment.

#### HARVEST TIME ADJUSTMENT

The amount of harvest time may be adjusted. It is preset from the factory at about three minutes, which should be adequate to release all cubes and fill the reservoir. If the timer needs to be adjusted, follow these steps:

- 1) Unplug the ice maker or disconnect the electrical power.
- 2) Remove the kickplate/grille.
- 3) Remove the control box cover.
- 4) Locate the timer shown in the illustration below. Loosen the set screw that holds the two halves of the timer cam together.
- 5) Rotate one half of the cam to open or close the lower portion of the cam. More of an opening equals more harvest time and less of an opening means less harvest time.
- 6) Tighten the set-screw.
- 7) Replace the control box cover and kickplate/grille.
- 8) Reconnect the electrical power.

#### ⚠ WARNING

**Electrical Shock Hazard—Disconnect electrical power before beginning removal of parts.**

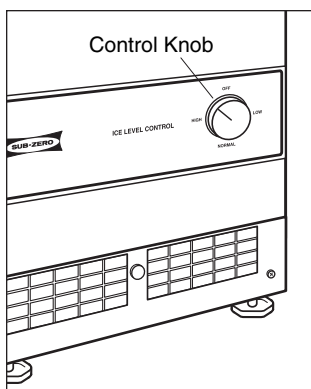

Ice maker control knob

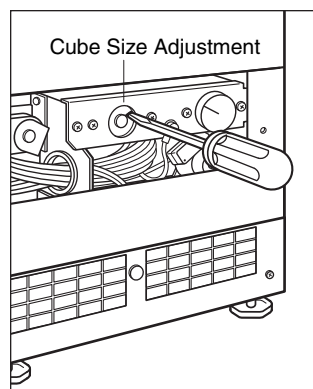

Cube size adjustment

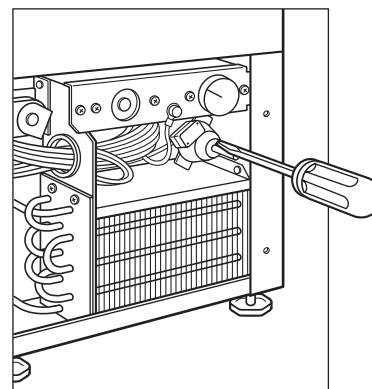

Harvest time adjustment



TROUBLESHOOTING GUIDE

SERVICE CENTER

Contact your Sub-Zero dealer or check the Locator section of our website, [subzero.com](http://subzero.com), for the authorized service center nearest you.

PROBLEM	POSSIBLE CAUSE	POSSIBLE SOLUTION
<b>Ice maker does not operate</b>	Ice maker is unplugged	Plug ice maker in
	Breaker tripped or fuse is blown	Reset breaker or replace fuse – if it happens again, call a Sub-Zero authorized service center
	Ice maker control turned to OFF	Turn ice maker control to ON
	Storage bin thermostat open, keeping ice maker off	Ice on sensor tube – it is normal for ice maker to be off Ice maker in room below 50°F (10°C) – room must be warmer for ice maker to operate Storage bin thermostat stuck open, must be replaced
	Timer contacts open	Replace timer
<b>Ice cubes are too large</b>	Cube size control set too cold	Adjust cube size control for smaller cubes (see page 18)
<b>Ice cubes are too small</b>	Cube size control set too warm	Adjust cube size control for larger cubes (see page 18)
	Not enough water	Check water supply – filter may be restricted Check inlet water valve – inlet screen may be restricted
	Cube size control stuck closed – timer runs all the time	Replace timer
<b>Ice cubes are partially formed – ragged sides</b>	Spray jets partially clogged	Clean ice making system with ice maker cleaner (see page 18)
<b>Ice maker makes ice, but storage bin does not fill with ice</b>	Storage bin should fill with ice and ice maker shut off in 24–36 hours – if not, condenser may be dirty	Clean condenser (see page 17)
	Storage bin drain may be partially restricted	Clean out drain, check installation
	Air flow to ice maker may be obstructed	Check installation – kickplate/grille must be free of obstructions
<b>Ice cubes are partially formed – white at the bottom</b>	Not enough water in reservoir	Check water supply – filter may be restricted Check inlet water valve – inlet screen may be restricted Check for water leak in reservoir



## TROUBLESHOOTING GUIDE

PROBLEM	POSSIBLE CAUSE	POSSIBLE SOLUTION
<b>Unit operates but no ice falling in storage bin</b>	Ice may be stuck in the evaporator and the unit is "frozen up"	<p>Check water supply – filter may be restricted</p> <p>Check inlet water valve – inlet screen may be restricted or valve does not operate</p> <p>Hot gas valve may not operate – check and repair or replace</p> <p>Harvest time set too short – timer needs adjustment (see page 19)</p>
	Too much heat load	Inlet water valve leaks through, must be replaced
	No water spray	Water pump does not operate, must be replaced or check for water leak in reservoir
	No airflow	<p>Fan motor does not operate or fan blade is broken, must be replaced</p> <p>Condenser completely blocked, must be cleaned (see page 17)</p>
	Cube size control will not close	<p>Defective control, must be replaced</p> <p>Inlet water valve leaks through, must be replaced or not enough refrigerant, call a Sub-Zero authorized service center</p>
	Compressor does not operate properly or at all	<p>Start relay or capacitor must be replaced</p> <p>Call a Sub-Zero authorized service center</p>
	Not enough refrigerant	Call a Sub-Zero authorized service center
	Restricted system	Call a Sub-Zero authorized service center
Hot gas valve leaks through	Call a Sub-Zero authorized service center	



## SERVICE INFORMATION

### SERVICE INFORMATION

If you do need service, be sure to have the model and serial number of your unit when you call. You'll find these numbers on the model and serial number plate located on the left sidewall of the reservoir. For warranty purposes, you will also need the date of installation and the name of your Sub-Zero dealer. Record this information below for future reference.

Model Number \_\_\_\_\_

Serial Number \_\_\_\_\_

Installation Date \_\_\_\_\_

Sub-Zero Authorized Service Center and Phone  
\_\_\_\_\_

Sub-Zero Dealer and Phone  
\_\_\_\_\_

### BEFORE CALLING FOR SERVICE

Before calling a Sub-Zero authorized service center, refer to the Troubleshooting Guide on pages 20–21. Check the household fuse or circuit breaker to see if it has been blown or tripped and that the electrical connection to the appliance has not been disconnected. A power outage may also have caused a disruption in service.

### PRODUCT REGISTRATION

Register your new Sub-Zero today so that we may ensure your satisfaction. You may register by one of the following options:

- 1) Mail in the completed Sub-Zero Product Registration Card.
- 2) Register online at **subzero.com**.
- 3) Register by phone by calling the Sub-Zero Customer Service Department at **800-222-7820**.

The model and serial numbers of your unit are printed on the enclosed Sub-Zero Product Registration Card. If you provide us with your e-mail address, we will send you exciting new product updates and recipes as they become available, along with information on special events.

**The information and images in this guide are the copyright property of Sub-Zero Freezer Company, Inc. Neither this book nor any information or images contained herein may be copied or used in whole or in part without the express written permission of Sub-Zero Freezer Company, Inc.**

**©Sub-Zero Freezer Company, Inc. all rights reserved.**

### CONTACT INFORMATION

**Sub-Zero  
Customer Service:  
800-222-7820**

**Website:  
subzero.com**

## **SUB-ZERO FREEZER COMPANY PRODUCTS LIMITED WARRANTY**

RESIDENTIAL USE ONLY

### **FULL FIVE YEAR SEALED SYSTEM WARRANTY LIMITED SIXTH THROUGH TWELFTH YEAR WARRANTY ON THE SEALED SYSTEM FULL TWO YEAR WARRANTY ON TOTAL PRODUCT\***

#### **FULL FIVE YEAR SEALED SYSTEM WARRANTY**

For five years from the date of original installation, your Sub-Zero warranty covers all parts and labor to repair or replace any components that prove to be defective in materials or workmanship in the sealed system. The sealed system consists of the compressor, condenser, evaporator, drier and all connecting tubing.

#### **FULL TWO YEAR WARRANTY\***

For two years from the date of original installation, your Sub-Zero warranty covers all parts and labor to repair or replace any part of the product, that proves to be defective in materials or workmanship.

#### **LIMITED SIXTH THROUGH TWELFTH YEAR SEALED SYSTEM WARRANTY**

From the 6th through the 12th year from the date of original installation, your Sub-Zero warranty covers all parts that prove to be defective in materials or workmanship in the sealed system (parts only). The sealed system consists of the compressor, condenser, evaporator, drier and all connecting tubing.

#### **TERMS APPLICABLE TO EACH WARRANTY**

All service provided by Sub-Zero under the above warranty must be performed by an authorized Sub-Zero service center, unless otherwise specified by Sub-Zero. Service will be provided in the home during the normal business hours. This warranty applies only to products installed for normal residential use. Details regarding a non-residential warranty are available upon request.

The warranty applies only to products installed in any one of the fifty states of the United States, the District of Columbia or the ten provinces of Canada. This warranty does not cover any parts or labor to correct any defect caused by negligence, accident or improper use, maintenance, installation, service or repair, including but not limited to improper removal and reinstallation (whether in the unit or at a remote location) of the condensing unit.

**THE REMEDIES DESCRIBED ABOVE FOR EACH WARRANTY ARE THE ONLY ONES THAT SUB-ZERO WILL PROVIDE, EITHER UNDER THESE WARRANTIES OR UNDER ANY WARRANTY ARISING BY OPERATION OF LAW. SUB-ZERO WILL NOT BE RESPONSIBLE FOR ANY CONSEQUENTIAL OR INCIDENTAL DAMAGES ARISING FROM THE BREACH OF THESE WARRANTIES OR ANY OTHER WARRANTIES, WHETHER EXPRESS, IMPLIED OR STATUTORY.**

Some states do not allow the exclusion or limitation of incidental or consequential damages, so the above limitation or exclusion may not apply to you. This warranty gives you specific legal rights and you may also have other legal rights, which vary from state to state.

To receive parts and/or service and the name of the Sub-Zero authorized service center nearest you, contact your Sub-Zero dealer, distributor or Sub-Zero Freezer Company, Customer Service Department, P.O. Box 44130, Madison Wisconsin, 53744-4130; check the Locator section of our website, subzero.com, or call 800-222-7820.

\* Stainless Steel (classic, platinum and carbon) doors, panels, product frames and stainless interior surfaces are covered by a limited 60 day parts and labor warranty for cosmetic defects.

\* Replacement water filter cartridges are not covered by the product warranty.



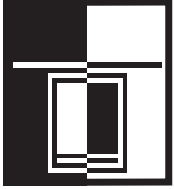

SUB-ZERO FREEZER COMPANY, INC. P. O. BOX 44130 MADISON, WI 53744-4130 800-222-7820 SUBZERO.COM



17307901

8/2005



## Free Manuals Download Website

<http://myh66.com>

<http://usermanuals.us>

<http://www.somanuals.com>

<http://www.4manuals.cc>

<http://www.manual-lib.com>

<http://www.404manual.com>

<http://www.luxmanual.com>

<http://aubethermostatmanual.com>

Golf course search by state

<http://golfingnear.com>

Email search by domain

<http://emailbydomain.com>

Auto manuals search

<http://auto.somanuals.com>

TV manuals search

<http://tv.somanuals.com>