

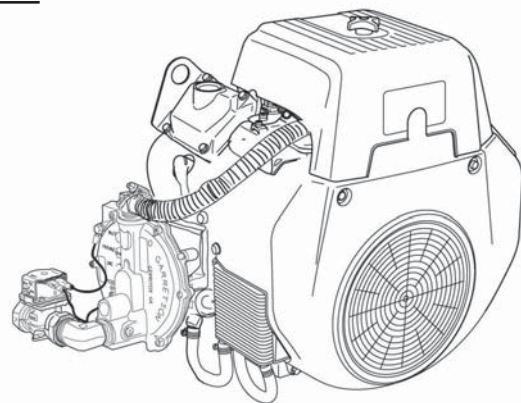

EH72D

LPG / NATURAL GAS Fueled Engine

INSTRUCTIONS FOR USE



2ZZ9020143

北米

Robin Engines

(California Proposition 65)

⚠ WARNING: ⚠	
The engine exhaust from this product contains chemicals known to the State of California to cause cancer, birth defects or other reproductive harm.	

(California only)

AIR INDEX

To show compliance with California emission regulations, a hangtag has been provided displaying the Air Index level and durability period of this engine.

The Air Index level defines how clean an engine's exhaust is over a period of time. A bar graph scaled from "0" (most clean) to "10" (least clean) is used to show an engine's Air Index level. A lower Air Index level represents cleaner exhaust from an engine.

The period of time (in hours) that the Air Index level is measured is known as the durability period. Depending on the size of the engine, a selection of time periods can be used to measure the Air Index level (see below).

<u>Descriptive Term</u>	<u>Applicable to Emissions Durability Period</u>
Moderate	50 hours (engine from 0 to 80 cc) 125 hours (engine greater than 80 cc)
Intermediate	125 hours (engine from 0 to 80 cc) 250 hours (engine greater than 80 cc)
Extended	300 hours (engine from 0 to 80 cc) 500 hours (engine greater than 80 cc)

Notice: This hangtag must remain on this engine or piece of equipment, and only be removed by the ultimate purchaser before operation.

Notice : FEDERAL EMISSION COMPONENT DEFECT WARRANTY and CALIFORNIA EMISSION CONTROL WARRANTY are applicable to only those engines / generators complied with EPA (Environmental Protection Agency) and CARB (California Air Resources Board) emission regulations in the U.S.A.

Notice : To the engines/generators exported to and used in the countries other than the U.S.A., warranty service shall be performed by the distributor in each country in accordance with the standard Subaru engine/generator warranty policy as applicable.

FEDERAL EMISSIONS COMPONENT DEFECT WARRANTY

EMISSIONS COMPONENT DEFECT WARRANTY COVERAGE - This emission warranty is applicable in all States, except the state of California.

Fuji Heavy industries Ltd. and Robin America, Inc., Lake Zurich, Illinois, (herin "ROBIN AMERICA") warrant(s) to the initial retail purchaser and each subsequent owner, that this Nonroad engine (herein "engine") has been designed, and equipped to conform at the time of initial sale to all applicable regulations of the U.S.

Environmental Protection Agency (EPA), and that the engine is free of defects in material and workmanship which would cause this engine to fail to conform with EPA regulations during its warranty period.

For the components listed under PARTS COVERED, the service dealer authorized by ROBIN AMERICA will, at no cost to you, make the necessary diagnosis, repair, or replacement necessary to ensure that the engine complies with applicable U.S. EPA regulations.

EMISSION COMPONENT DEFECT WARRANTY PERIOD

The warranty period for this engine begins on the date of sale to the initial purchaser and continues for a period of two years.

PARTS COVERED

Listed blow are the parts covered by the Emission Components Defect Warranty. Some of the parts listed below may require scheduled maintenance and are warranted up to the first scheduled replacement point for that part.

EXHAUST EMISSIONS

- (1) Fuel Metering System
 - (i) Carburetor and internal parts (and/or pressure regulator or fuel injection system.)
 - (ii) Air/fuel ratio feedback and control system, if applicable.
 - (iii) Cold start enrichment system, if applicable.
 - (iv) Regulator assy (gaseous fuel, if applicable).
- (2) Air Induction System
 - (i) Intake manifold, if applicable
 - (ii) Air filter
- (3) Ignition System
 - (i) Spark Plugs
 - (ii) Magneto or electronic ignition system.
 - (iii) Spark advance/retard system, if applicable.
- (4) Exhaust manifold, if applicable
- (5) Miscellaneous Items Used in Above Systems
 - (i) Electronic controls, if applicable
 - (ii) Hoses, belts, connectors, and assemblies.
 - (iii) Filter lock assy (gaseous fuel, if applicable).

*EVAPORATIVE EMISSIONS

- (1) Fuel Line
- (2) Fuel Line Fittings
- (3) Clamps

*Fuji is not liable for the warranty on these parts if these parts are installed on the engine by the equipment manufacturer. Please refer to the equipment manufactures warranty.

OBTAINING WARRANTY SERVICE

To obtain warranty service, take your engine to the nearest authorized Robin America service dealer. Bring your sales receipts indicating date of purchase for this engine. The service dealer authorized by ROBIN AMERICA will perform the necessary repairs or adjustments within a reasonable amount of time and furnish you with a copy of the repair order. All arts and accessories replaced under this warranty become the property of ROBIN AMERICA.

WHAT IS NOT COVERED

*Conditions resulting from tampering, misuse, improper adjustment (unless they were made by the service dealer authorized by ROBIN AMERICA during a warranty repair), alteration, accident, failure to use the recommended fuel and oil, or not performing required maintenance services.

*The replacement parts used for required maintenance services.

*Consequential damages such as loss of time, inconvenience, loss of use of the engine or equipment, etc.

*Diagnosis and inspection charges that do not result in warranty-eligible service being performed.

*Any non-authorized replacement part, or malfunction of authorized parts due to use of non-authorized parts.

OWNER'S WARRANTY RESPONSIBILITIES

As the engine owner, you are responsible for the performance of the required maintenance listed in your owner's manual. ROBIN AMERICA recommends that you retain all receipts covering maintenance on your engine, but ROBIN AMERICA cannot deny warranty solely for the lack of receipts or for your failure to ensure the performance of all scheduled maintenance.

As the engine owner, you should however be aware that ROBIN AMERICA may deny warranty coverage if your engine or part has failed due to abuse, neglect, improper maintenance or unapproved modifications.

You are responsible for presenting your engine to the nearest service dealer authorized by ROBIN AMERICA when a problem exists.

If you have any questions regarding your warranty rights and responsibilities, you should contact the Robin America customer service department at 1-800-277-6246 for the information.

THINGS YOU SHOULD KNOW ABOUT THE EMISSION CONTROL SYSTEM WARRANTY MAINTENANCE AND REPAIRS

You are responsible for the proper maintenance of the engine. You should keep all receipts and maintenance records covering the performance of regular maintenance in the event questions arise. These receipts and maintenance records should be transferred to each subsequent owner of the engine. ROBIN AMERICA reserves the right to deny warranty coverage if the engine has not been properly maintained. Warranty claims will not be denied, however, solely because of the lack of required maintenance or failure to keep maintenance records.

MAINTENANCE, REPLACEMENT OR REPAIR OF EMISSION CONTROL DEVICES AND SYSTEMS MAY BE PERFORMED BY ANY REPAIR ESTABLISHMENT OR INDIVIDUAL; HOWEVER, WARRANTY REPAIRS MUST BE PERFORMED BY A SERVICE DEALER AUTHORIZED BY ROBIN AMERICA. THE USE OF PARTS THAT ARE NOT EQUIVALENT IN PERFORMANCE AND DURABILITY TO AUTHORIZED PARTS MAY IMPAIR THE EFFECTIVENESS OF THE EMISSION CONTROL SYSTEM AND MAY HAVE A BEARING ON THE OUTCOME OF A WARRANTY CLAIM.

If other than the parts authorized by ROBIN AMERICA are used for maintenance replacements or for the repair of components affecting emission control, you should assure yourself that such parts are warranted by their manufacturer to be equivalent to the parts authorized by ROBIN AMERICA in their performance and durability.

HOW TO MAKE A CLAIM

All repair qualifying under this limited warranty must be performed by a service dealer authorized by ROBIN AMERICA. In the event that any emission-related part is found to be defective during the warranty period, you shall notify Robin America customer service department at 1-800-277-6246 and you will be advised of the appropriate warranty service dealer or service providers where the warranty repair can be performed.

WS6645

FOREWORD

Thank you very much for purchasing a ROBIN ENGINE.

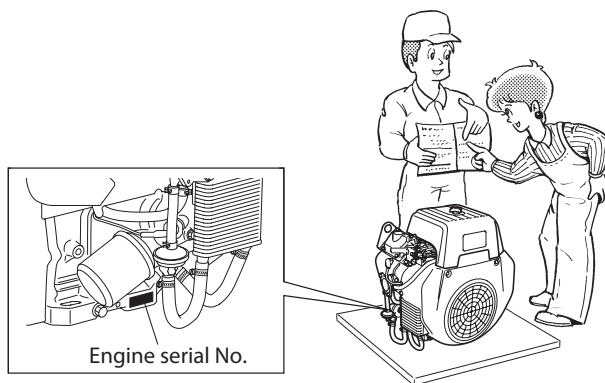

Your SUBARU ENGINE can supply the power to operate various sorts of machines and equipment. Please take a moment to familiarize yourself with the proper operation and maintenance procedures in order to maximize the safe and efficient use of this product.

Due to constant efforts to improve our products, certain procedures and specifications are subjected to change without notice.

When ordering spare parts, always give us the MODEL, SPECIFICATION and SERIAL NUMBER of your engine.

Please fill in the following blanks after checking the specification number on your engine.

SPEC NO.

E	H																		
---	---	--	--	--	--	--	--	--	--	--	--	--	--	--	--	--	--	--	--

SERIAL NO.

--	--	--	--	--	--	--	--









For your nearest SUBARU distributor (and/or dealer), you are able to check at our SUBARU website of the following URL;





<http://www.subarupower.com>

CONTENTS

SAFETY PRECAUTIONS	1
COMPONENTS.....	4
PRE-OPERATION CHECKS.....	5
BATTERY INSTALLATION	7
OPERATING YOUR ENGINE	9
EASY TROUBLESHOOTING	10
MAINTENANCE SCHEDULE	12
“HOW-TO” MAINTENANCE	14
PREPARATIONS FOR STORAGE	17
SPECIFICATIONS.....	18

SYMBOLS

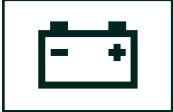
	Read the owner's manual
	Stay clear of the hot surface
	Exhaust gas is poisonous. Do not operate in an unventilated area.
	Stop the engine before refueling
	Fire, open flame and smoking prohibited
	Fire
	Explosion
	Explosive Pressure

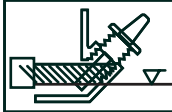

	On (Run)		Plus ; positive polarity
	Off (Stop)		Battery
	Engine oil		Engine start (Electric start)
	Add oil		



SAFETY PRECAUTIONS

The safety alert symbol () is used with a signal word (**DANGER**, **CAUTION**, **WARNING**), a pictorial and/or a safety message to alert you to hazards.

DANGER indicates a hazard which, if not avoided, will result in death or serious injury. **WARNING** indicates a hazard which, if not avoided, could result in death or serious injury. **CAUTION** indicates a hazard which, if not avoided, might result in minor or moderate injury. **NOTICE** indicates a situation that could result in engine damage. Follow safety messages to avoid or reduce the risk of injury or death.

The manufacturer cannot possibly anticipate every possible circumstance that might involve a hazard. The warnings in this manual, and the tags and decals affixed to the unit are, therefore, not all-inclusive. If you use a procedure, work method or operating technique that the manufacturer does not specifically recommend you must satisfy yourself that it is safe for you and others. You must also make sure that the procedure, work method or operating technique that you choose does not render the engine system unsafe.

 WARNING	
	Running engine gives off carbon monoxide, and odorless, colorless, poison gas. Breathing carbon monoxide can cause headache, fatigue, dizziness, vomiting, confusion, seizures, nausea, fainting or death.
<ul style="list-style-type: none"> • Operate engine ONLY outdoors. • Keep exhaust gas from entering a confined area through windows, doors, ventilation intakes, or other openings. 	

 WARNING	
 	Propane and Natural Gas are extremely flammable and explosive. Fire or explosion can cause severe burns or death.
<ul style="list-style-type: none"> • Install the fuel supply system according to applicable fuel-gas codes. • Before placing the engine into service, the fuel system lines must be properly purged and leak tested. Procedures used in gaseous fuel leakage tests must comply strictly with applicable fuel gas codes. • DO NOT use flame or any source of heat to test for gas leaks. • NO leakage is permitted. • LP gas is heavier than air and will settle in low areas. • Natural gas is lighter than air and will collect in high areas. • DO NOT operate engine if smell of fuel is present or other explosive conditions exist. • The slightest spark can ignite these fuels and cause an explosion. • DO NOT smoke around the engine. Wipe up any oil spills immediately. Keep the area near the engine clean and free of debris. 	

SAFETY PRECAUTIONS

Please make sure you review each precaution carefully.

EXHAUST PRECAUTIONS

- Never inhale gas.
It contains carbon monoxide, a colorless, odorless and extremely dangerous gas which can cause unconsciousness or death.
- Never operate the engine indoors or in a poorly ventilated area, such as tunnel, cave, etc.
- Exercise extreme care when operating the engine near people or animals.
- Keep the exhaust pipe free of foreign objects.

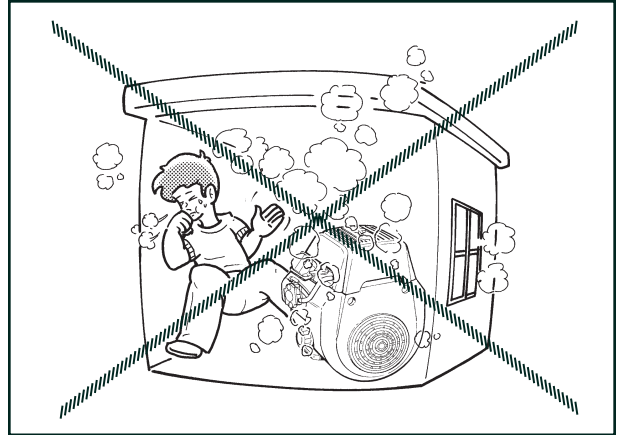

REFUELING PRECAUTIONS

- Be sure to stop the engine prior to connecting a fuel line. Refuel outdoors, in a well-ventilated area.
- Use only approved LP/NG fuel hose and connectors.
- Check for fuel leaks before operating the engine.

FIRE PREVENTION

- LPG is extremely flammable and combustible, and so is NATURAL gas.
- Do not operate while smoking or near an open flame.
- Do not use around dry brush, twigs, cloth rags, or other flammable materials.
- Keep the engine at least 3 feet (1 meter) away from buildings or other structures.
- Keep the engine away from flammables and other hazardous material (trash, rags, lubricants, explosives).
- DO not leave cigarettes, sparks and flames near by any fuel-related parts.
- Never smoke near LPG or Natural gas and keep other flames and sparks away.
- In order to reduce the risk of the fire or explosion, be careful when working around LPG or Natural gas.

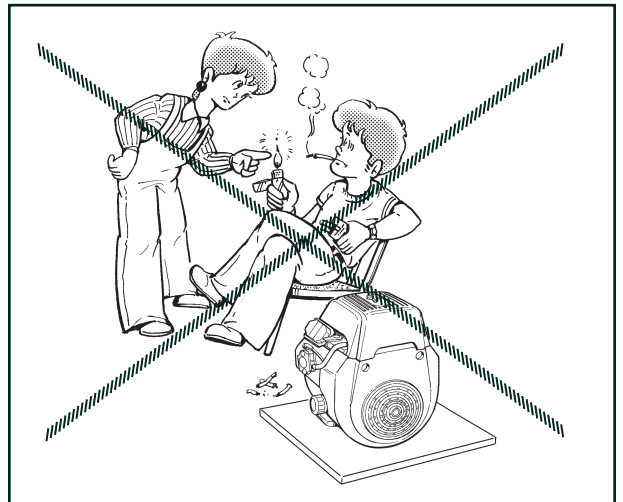

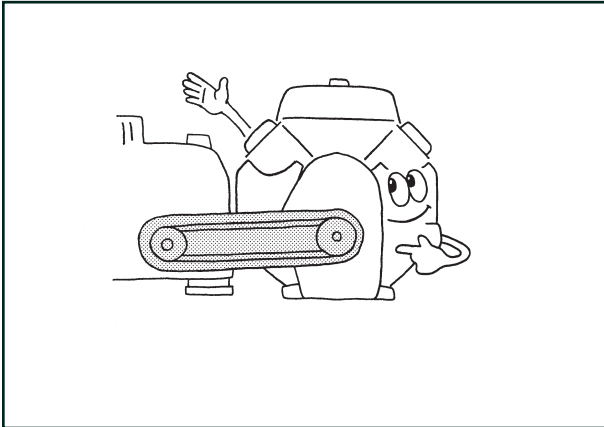

PROTECTIVE COVER

- **Place the protective covers over the rotating parts.**

If rotating parts such as the drive shaft, pulley, belt, etc. are left exposed, they are potentially hazardous.

To prevent injury, equip them with protective covers or shrouds.

- **Be careful of hot parts.**

The muffler and other engine parts become very hot while the engine is running or just after it has stopped.

Operate the engine in a safe area and keep children away from the running engine.

- Never make adjustments on the machinery while it is connected to the engine, without first removing the ignition cable from the spark plug. Turning the crankshaft by hand during adjusting or cleaning might start the engine, and the machinery with it, causing serious injury to the operator.
- Never run the engine with governor disconnected, or operate at speeds in excess of 3600 rpm load.

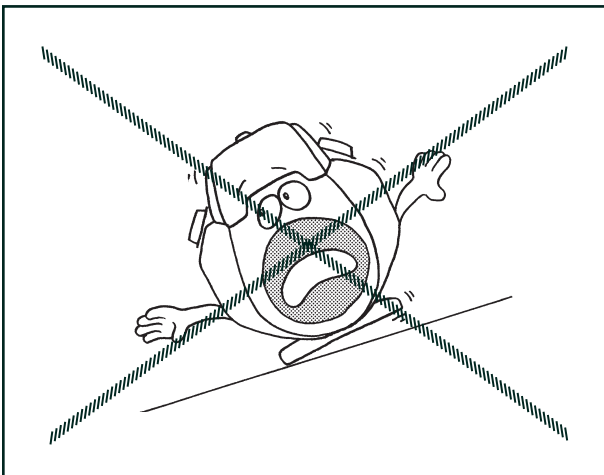

SURROUNDINGS

- Operate the engine on a stable, level surface free of small rocks, loose gravel, etc.

NOTE

Operating the engine at a steep incline may cause seizure due to improper lubrication even with a maximum oil level.

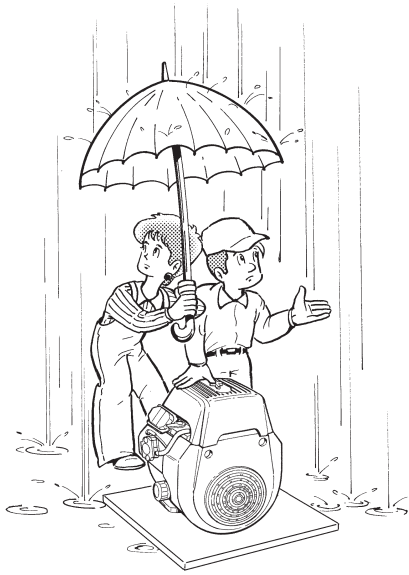

- Disconnect the LP/NG fuel line before transporting the engine.
- Do not move the engine while in operation when it has been removed from the equipment.
- Keep the unit dry (do not operate it in rainy conditions).

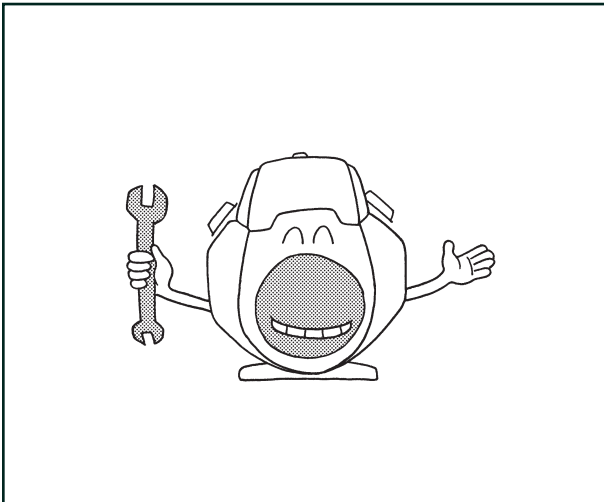

PRE-OPERATION CHECKS

- Carefully check fuel hoses and connections for looseness and LPG or Natural Gas leakage. Leaking fuel creates a potentially dangerous situation.
- Check bolts and nuts for looseness. A loose bolt or nut may cause serious engine trouble.
- Check the engine oil daily and refill if necessary.
- Check the fuel level and refill if necessary.
- Wear snug fitting working clothes when operating the engine. Loose aprons, towels, belt, etc., may be caught in the engine or drive train, causing a dangerous situation.

COMPONENTS

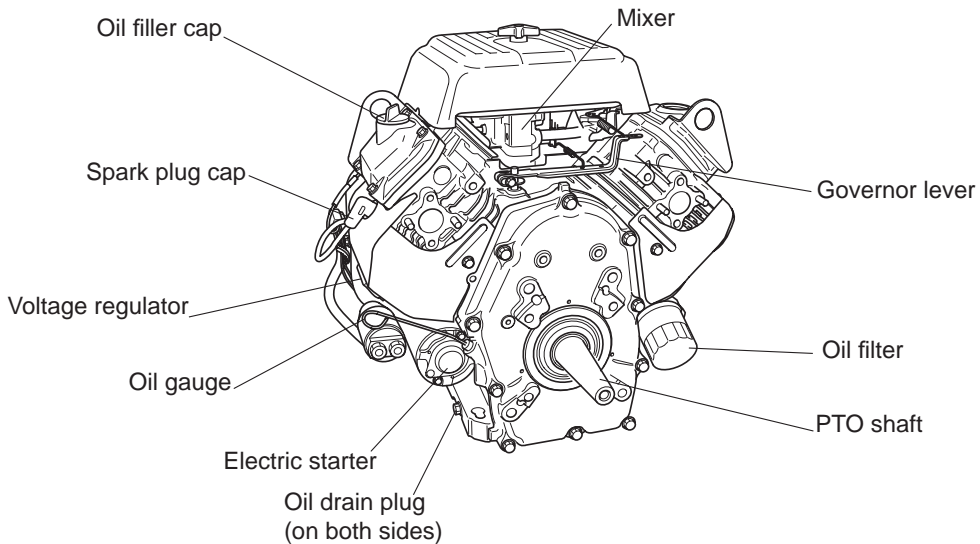
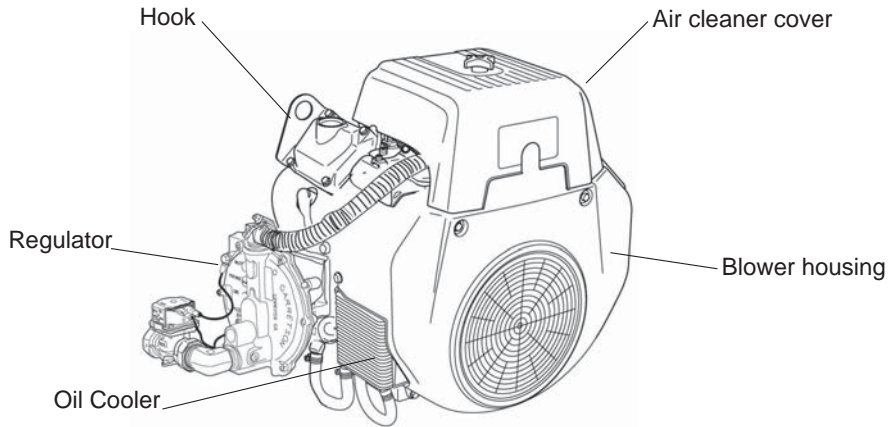

REMARKS:

- Fuel tank, valve, (sediment bowl type is recommended), fuel hoses, and fuel filter are required for connecting fuel source to this engine.
- A battery rated at 12V-36AH or larger with the specified cable are required for electric starter operation. Make the proper electrical wiring arrangements before normal engine operation. (See "Battery Installation" for detailed information and data.)

PRE-OPERATION CHECKS

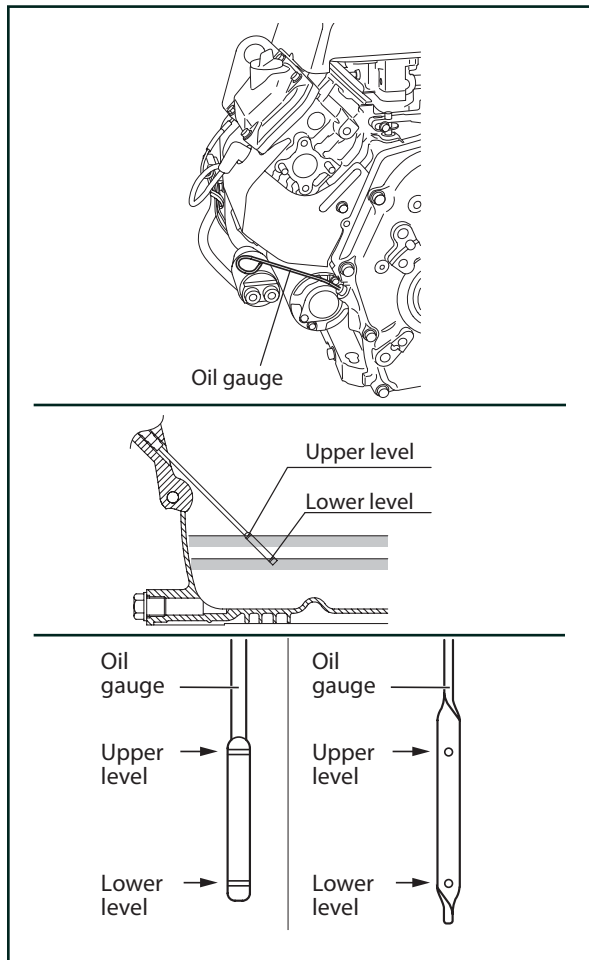

ENGINE OIL (CHECK DAILY)

Before checking or refilling engine oil, be sure the engine is not running and is located on a stable, level surface.

- If the oil level is below the lower level line on the oil gauge, refill with the proper oil (see table) to the upper level.

OIL CAPACITY : 1.55 liter (1.64 qt.)

- When filling oil in the engine, keep the engine level and fill the oil up to the upper mark of the oil gauge. Measure the oil level with the oil gauge plugged in position .
- After an oil change, run the engine, and recheck the oil level. The oil level may drop a little as the oil fills the oil filter. Fill the oil up to the upper mark of the oil gauge.
- Change oil if it is contaminated. (See "Maintenance Schedule")
- Use 4-stroke automotive detergent oil of API service class SE or higher grade (SG, SH or SJ is recommended).
- If multi-grade oil is used, oil consumption tends to increase when the ambient temperature is high.

Single grade	5W						
	10W						
		20W					
			#20				
				#30			
					#40		
Multi grade	10W-30						
	10W-40						
Ambient temperature	-20	-10	0	10	20	30	40°C
	-4	14	32	50	68	86	104°F

GASEOUS FUEL

WARNING

Do not refuel while smoking, near an open flame or other potential hazards.

Fuel Recommendations

LPG	Propane content of 95% or higher
NATURAL GAS	Methane content of 90% or equivalent

INSTRUCTIONS FOR CONVERTING TO NATURAL GAS OPERATION

The engine is optimized for LP operation from the factory. The steps below show how to remove the orifice for NATURAL GAS operation.

1. Remove Air Cleaner Assembly
2. Loosen fuel hose clamp and remove the 1" black fuel hose from the front of the carburetor
3. Remove threaded brass orifice with either flat head screw driver or pliers
4. Replace fuel line hose and tighten clamp
5. Replace Air Cleaner Assembly
6. Check for leaks using the procedure below.

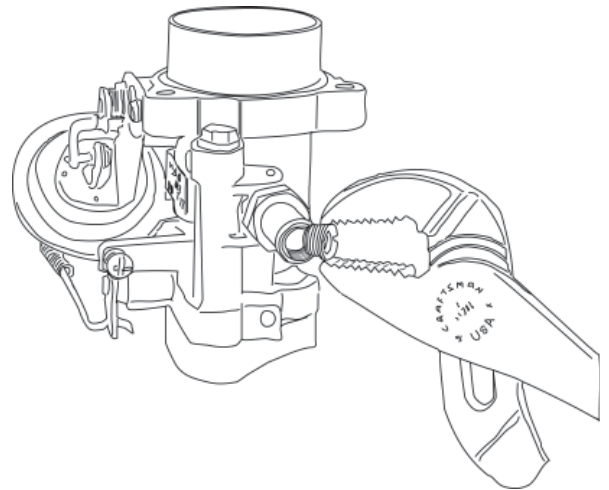

LEAK TESTING THE FUEL SYSTEM

1. Create a mixture of 50% water and 50% liquid dishwashing soap.
2. Turn ON the fuel supply by turning the LP fuel tank shut off valve on full turn COUNTER-CLOCKWISE.
3. Using a sponge, rag or small non-metallic brush, apply the soap water mixture at each of the connection locations of the fuel piping system.
4. Check each location for growing bubbles, which indicates a fuel leak.
5. Close the LP fuel shut off valve.
6. Tighten or replace any leaking connections.

VAPOR WITHDRAWAL

With a vapor withdrawal system, the LP fuel is vaporized in the fuel tank by heat input from the ambient temperature. The pressure is reduced to about 11" water column (0.4psi) on the outlet side of the primary regulator. The vaporized fuel is then brought to the engine and demand regulator on the engine reduces the pressure even further before it engine the carburetor (mixer). Approximately 10 to 20% of the tank capacity is needed for fuel expansion from the liquid to the vapor state. The user should be aware that when the ambient temperatures are low and engine fuel consumption is high, the vapor withdrawal system may not function efficiently. Ambient temperature around the supply tank must be high enough to sustain adequate vaporization for the system or it will not deliver the needed fuel volume.

LPG PIPING DIAGRAM

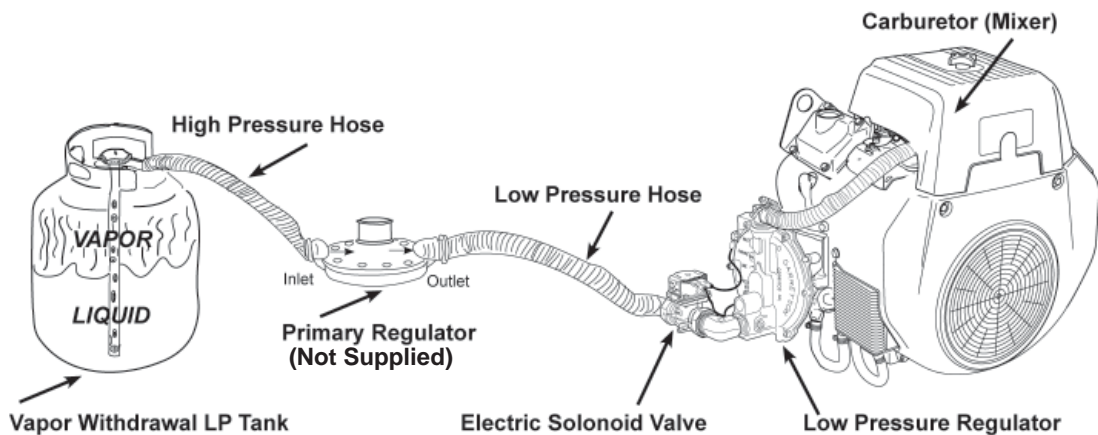

NATURAL GAS PIPING DIAGRAM

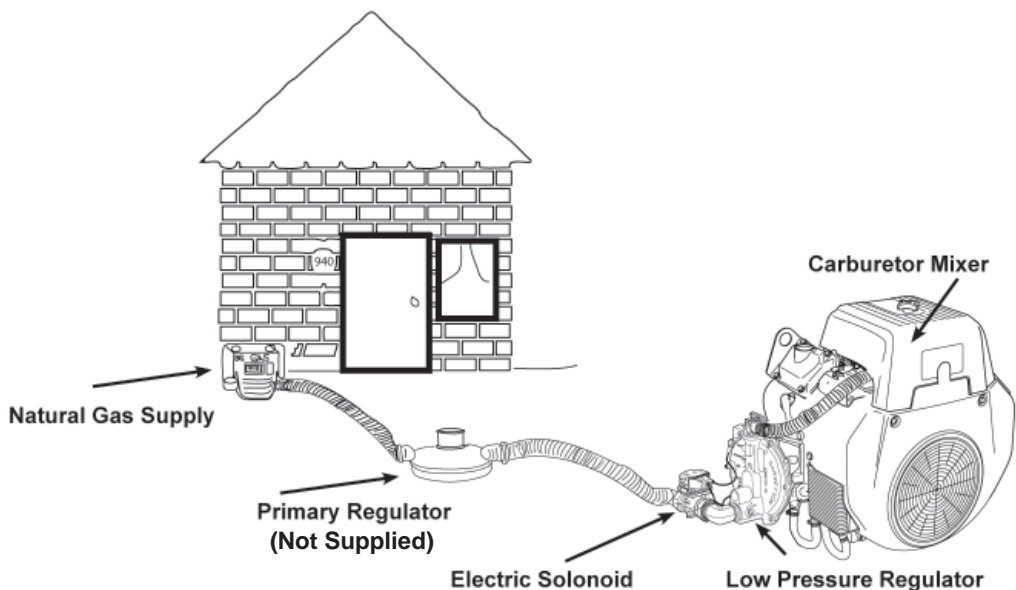

BATTERY INSTALLATION

For electric starter operation, proper electric wiring arrangements are needed before normal engine operation.

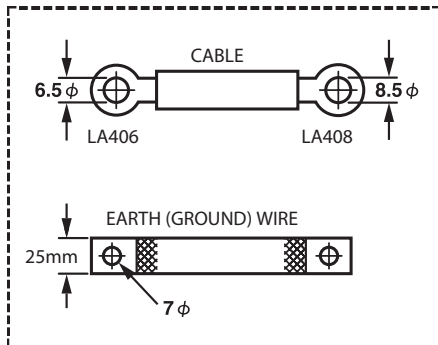
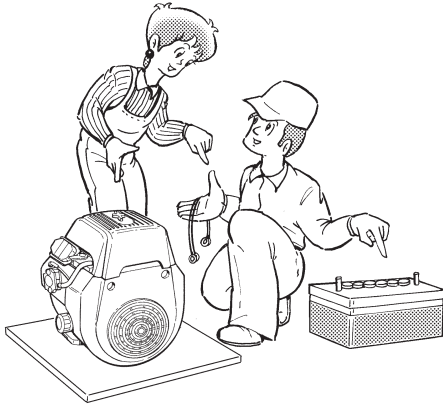

PARTS NEEDED

- Use a battery rated 12V-36AH or larger.
- Use a proper cable and ground wire to connect battery and key switch and electric starter.

PARTS NEEDED

CABLE LENGTH	CABLE DIA.	WIRE GAUGE		
		AWG (BS) BWG	SAE	JIS
Less than 1.5m	7.3mm	1	6	AV15
1.5m to 2.5m	8.5mm	0	4	AV20
2.5 m to 4.0m	10.8mm	3/0	2	AV30

EARTH (GROUND) WIRE, use a flat braided wire of 0.03 sq. in. or larger sectional area. (SAE GAUGE 4)

KEY SWITCH CABLE

CABLE LENGTH	CABLE DIA.	WIRE GAUGE		
		AWG (BS) BWG	SAE	JIS
Less than 1.5m	1.5mm	14	16	AV1.25
1.5m to 3.0m	1.9mm	120	14	AV2
3.0 m to 5.0m	2.4mm	10	13	AV3

WIRING

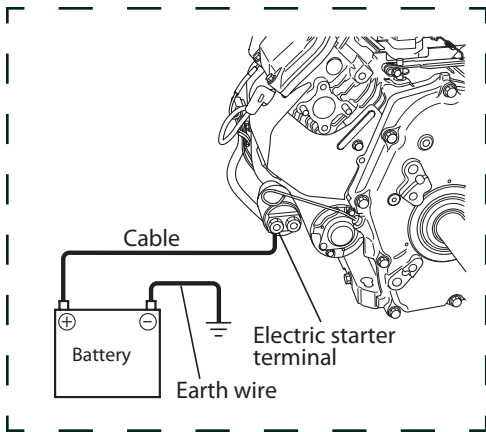

- Connect positive terminal of electric starter and positive terminal of the battery with battery cable.
- Ground negative terminal of the battery to the body of engine or machine with ground wire.

NOTE

Tighten bolts and nuts on terminals securely so they will not be loosened by vibration.

WIRING DIAGRAM

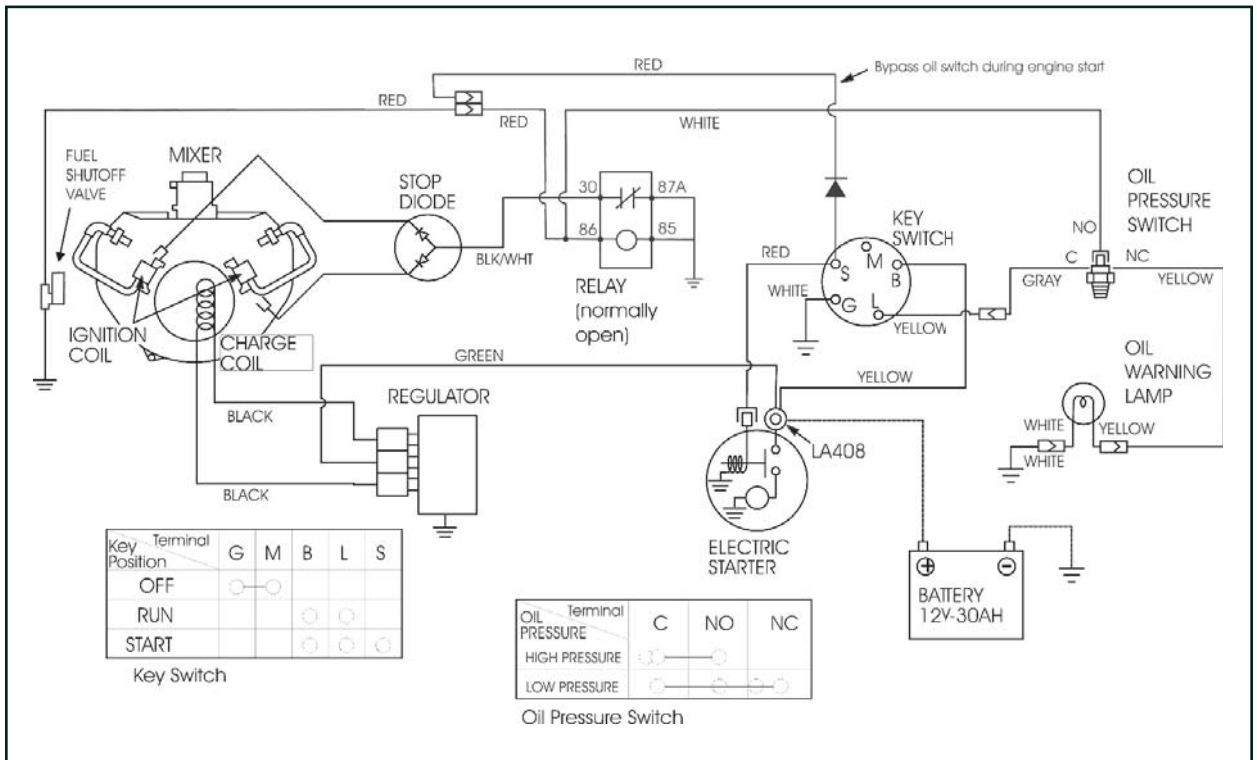

Optional hardware shown by dotted lines. Select wire of proper gauge and connect battery as shown by the dotted line in the wiring diagram.

OPERATING YOUR ENGINE

STARTING

FUEL VALVE

1

(Provided by the equipment manufacturer)

Open the fuel valve.

ELECTRIC STARTER

2



(Provided by the equipment manufacturer)

Turn the key switch to the “START” position.

- Do not operate the electric starter continuously for more than 5 seconds, even if the engine does not start.
- If the engine failed to start, set the key to the “RUN” position and wait for about 10 seconds before retrying.
- Never turn the key switch to the “START” position while engine is running.

STOPPING

ELECTRIC STARTER

1



Turn the key switch to the “STOP” position.

FUEL VALVE

2

Close the fuel valve.

EASY TROUBLESHOOTING

Perform the following checks before you take the engine to your Subaru dealer.
If you still have trouble after completing the checks, take the engine to your nearest Subaru dealer.

Checking Items	Possible Cause	Correction
----------------	----------------	------------

- **Engine will not start**

Check battery	Battery discharged	Recharge battery
Check control position (Power equipment side)	• Fuel valve CLOSED or OFF (if equipped)	Move fuel valve to OPEN or ON
	• Engine switch OFF	Turn engine switch to ON
Check battery	Out of fuel	Refuel
Remove and inspect spark plugs	Spark plugs faulty, fouled, or improperly gapped	Clean, gap or replace spark plugs

- **Engine lacks power**

Check air cleaner	Filter element clogged	Clean or replace filter element
-------------------	------------------------	---------------------------------

Is ther enough compression?

If the spark plug is loose, tighten it.

▲ WARNING

Wipe off spilled fuel carefully before checking the spark plug. Place spark plug as far away from spark plug hole as possible. Do not hold spark plug by hand while checking.

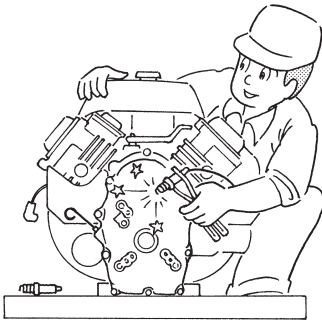

Is there a strong spark across the electrode?

1. Remove the spark plug and connect it to the plug cap.

Turn key switch to START position while grounding the spark plug against engine body.

2. Try with a new spark plug if the spark is weak or there is no spark.
3. The ignition system is faulty if there is no spark with a new spark plug. Take your engine to your nearest Subaru dealer.



Is your battery will charged?

Check the battery, it may be discharged and unable to operate the electric starter.

Consult your nearest dealer or service shop.

EASY TROUBLESHOOTING

DAILY INSPECTION

Before funning the engine, check the following service items.

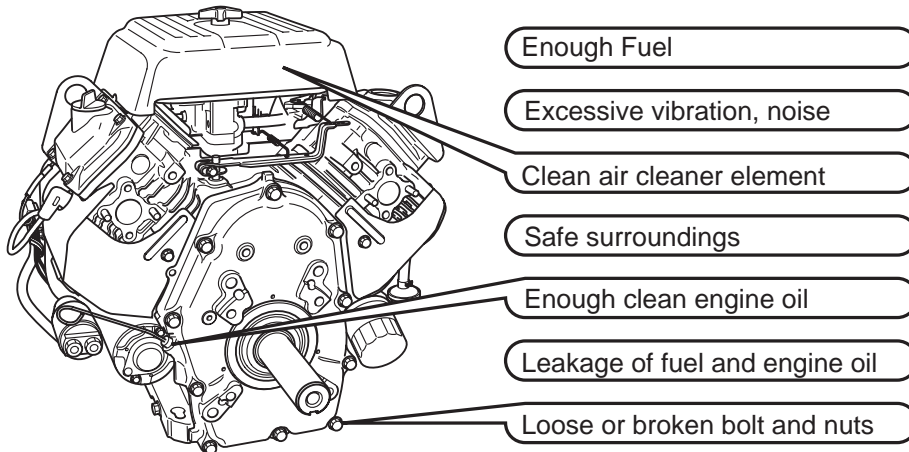

PERIODIC MAINTENANCE

Periodic maintance is vital to safe and efficient operation of your engine. Check the table below for periodic maintenance intervals.

(Periodic Maintenance Schedule Table)

Maintenance Items	Every 8 hours (Daily)	Every 50 hours	Every 200 hours	Every 500 hours	Every 1000 hours
Clean engine and check bolt and nuts	• (Daily)				
Check and refill engine oil	• (Refill daily to full level)				
Change engine oil (*Note 1)	• (Initial 20 hours)	•			
Replace engine oil filter (*Note 1)	• (Initial 20 hours)		•		
Check battery electrolyte fluid level		•			
Clean spark plug		•			
Clean air cleaner		•			
Clean fuel strainer			•		
Replace air cleaner element			•		
Clean and adjust spark plug and electrodes			•		
Clean mixer				•	
Clean cylinder head				•	
Clean engine base (oil pan)				•	
Cleck and adjust valve seats				•	
Check and adjust valve cleanance				•	
Replace spark plug				•	
Replace fuel and oil hose					•

*Note 1 : Initial oil change and oil filter replacement should be performed after 20 hours of operation.

Thereafter change oil every 50-100 hours and replace oil filter 200 hours.

More frequent oil changing, oil filter replacement and air cleaner service on replacement may be necessary depending on operation conditions.

This would include dusty environment, high ambient temperature, heavy engine loading.

Before changing oil, check for a suitable way to dispose of old oil. Do not pour it down into sewage drains, onto garden soil or into open streams. Your local zoning or environmental regulations will give you more detailed instructions on proper disposal.

*Note 2 : As to the procedures, please refer to the Service Manual or consult your nearest SUBARU service dealer.

“HOW-TO” MAINTENANCE

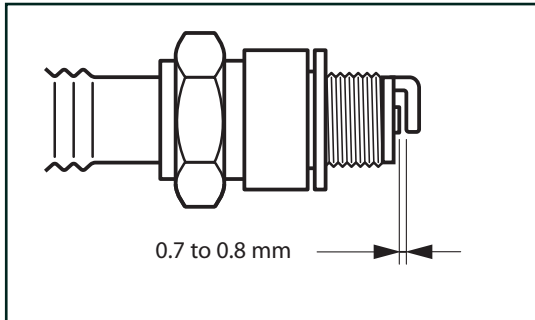

SPARK PLUG

- Clean and remove carbon deposits off from the spark plug electrode, using a plug cleaner or wire brush.
- Check if the electrode gap is in the proper range.
Adjust gap to the specifications:
0.7mm to 0.8mm
- Use a specified spark plug:
BPR6ES (NGK)

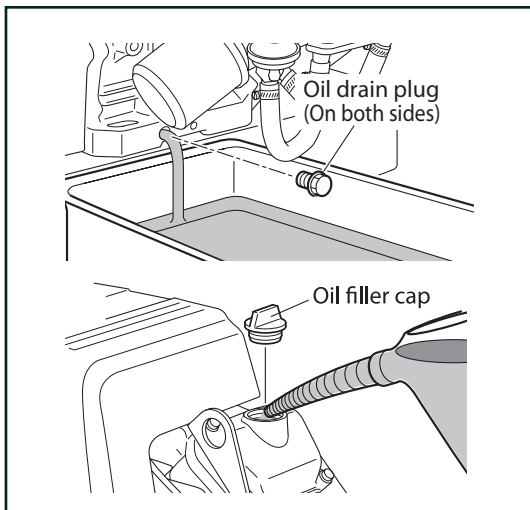

ENGINE OIL

- Initial oil change
.....After 20 hours of operation
 - Thereafter
.....Every 50 to 100 hours of operation
1. When changing oil, stop the engine and loosen the drain plug.
 2. Re-install the drain plug before refilling oil.
 3. Refer to the recommended oil table.
(See Pre-operation checks)
 4. Always use the best grade and clean oil.
Contaminated oil, poor quality oil and shortage of oil cause damage to engine or shorten the engine life.

OIL CAPACITY : 1.55 liter (1.64 qt.)

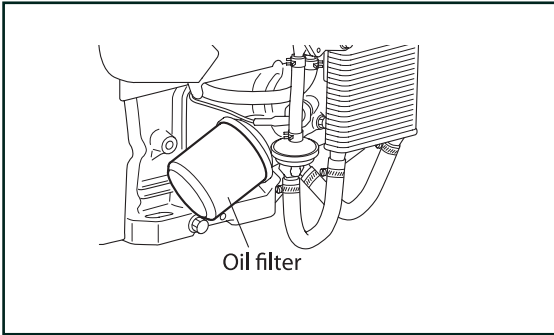

⚠ CAUTION

To prevent injury, pay attention to the spilled hot engine oil when replacing engine oil filter.

ENGINE OIL FILTER

- Initial engine oil filter replacement should be performed after 20 hours of operation. Thereafter replace the engine oil filter every 200 hours.
- When installing a new oil filter, apply oil to O-ring, attach the oil filter in position and tighten 2/3 turns by hand or with wrench after touching the O-ring to the sealing surface of engine.
- Run the engine for a minute; stop the engine and check for oil leakage around the oil filter and recheck the oil level.

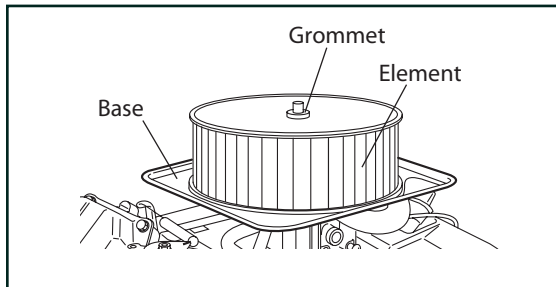
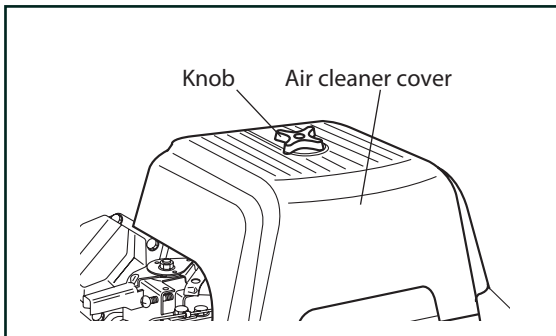

AIR CLEANER

A dirty air cleaner element will cause starting difficulty, power loss, engine malfunctions, and shorten engine life extremely.

Always keep the air cleaner element clean. Replace the air cleaner element more often in dusty environments.

The air cleaner paper element can be removed after removing knob and air cleaner cover.

When installing, set the paper element on the air cleaner base.

Check if the grommet is in position, and then install the cover with knob tightened securely.

-
- Paper element

Clean by taping gently to remove dirt and blow off dust. Never use oil.

Clean or replace paper element every 50 hours of operation, and replace element set every 200 hours or once a year.

Clean and replace air cleaner elements more often when operation in dusty environments.

BOLTS, NUTS AND SCREWS

Retighten loose bolts and nuts

Check for fuel and oil leaks

Replace damaged parts with new ones.

Keep safety in your mind.

FUEL AND OIL HOSE

WARNING

Take extreme caution when replacing fuel hose ; fuel is flammable.

Replace the fuel and oil hose every 1,000 hours or every year.

If fuel and oil hose leak is found, replace the fuel hose immediately.

BATTERY

WARNING

Battery electrolyte is an acid and is poisonous and corrosive.

Serious injury results from contact with the skin, eyes or clothing.

If the electrolyte fluid is below level line, refill battery with distilled water.

PREPARATIONS FOR STORAGE

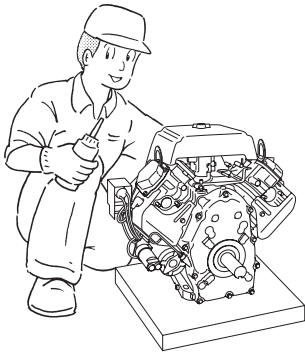

ENGINE OIL

- Change the engine oil with fresh oil.
- Remove the spark plug, pour about 5cc of engine oil into the cylinder, slowly start the engine for 2 or 3 seconds, and re-install the spark plug.



CLEAN AND STORE

- Remove the spark plug wires from the spark plugs.
- Slowly turn the crankshaft until resistance is felt and leave it in that position.
- Clean the engine thoroughly with an oiled cloth, cover the engine, and store the engine indoors in a well ventilated, low humidity area.

SPECIFICATIONS

MODEL	EH72 LP/NG
Type	Air-Cooled, 4-stroke, V-Twin Cylinder, Horizontal P.T.O. shaft, OHV, LPG/NATURAL GAS Fueled Engine
Bore x Stroke mm(in)	2-84 x 65 (3.31 x 2.56)
Displacement cm ³ (cu.in)	720 (43.9)
Maximum Torque N•m	39.5 N•m @ 2500rpm
Maximum Output	LPG (Propane content of 95% or higher) : 25hp18.6kw@3600rpm Natural Gas (Methane content of 90% or equivalent) : 21hp15.7kw@3600rpm
Direction of Rotation	Counterclockwise as viewed from P.T.O. shaft side
Lubricant	Automotive Engine Oil SAE #20, #30 or 10W-30; Class SE or higher (SG, SH or SJ is recommended)
Capacity of Lubricant	1.55 (52.48)
Fuel	LPG/NATURAL GAS
Spark Plug	BPR6ES (NGK)
Starting System	Electric Starter
Dry Weight	46 (101.3)
Dimension (L x W x H) kg (lb)	317 x 477 x 475 (12.5 x 18.8 x 18.7)
Valve Clearance (Intake & Exhaust)	0.1 to 0.02mm (0.0039 to 0.0008 in) Not: Adjust the valve clearance while the engine is cold.

ISSUE EMD-EU2415



SUBARU

FUJI HEAVY INDUSTRIES LTD.
INDUSTRIAL PRODUCTS COMPANY

4-410 ASAHI, KITAMOTO-SHI, SAITAMA, 364-8511, JAPAN
TEL: +81-48-593-7798, FAX: +81-48-593-7946
<http://www.fhi.co.jp/robin/>

Free Manuals Download Website

<http://myh66.com>

<http://usermanuals.us>

<http://www.somanuals.com>

<http://www.4manuals.cc>

<http://www.manual-lib.com>

<http://www.404manual.com>

<http://www.luxmanual.com>

<http://aubethermostatmanual.com>

Golf course search by state

<http://golfingnear.com>

Email search by domain

<http://emailbydomain.com>

Auto manuals search

<http://auto.somanuals.com>

TV manuals search

<http://tv.somanuals.com>