

**Models H62 & H63**

# **Shake/Slush Freezers**

**Original Operating Instructions**

**067343-M**



**4/1/09 (Original Publication)  
(Updated 4/16/12)**

**Complete this page for quick reference when service is required:**

Taylor Distributor: \_\_\_\_\_

Address: \_\_\_\_\_

Phone: \_\_\_\_\_

Service: \_\_\_\_\_

Parts: \_\_\_\_\_

Date of Installation: \_\_\_\_\_

**Information found on the data label:**

Model Number: \_\_\_\_\_

Serial Number: \_\_\_\_\_

Electrical Specs: Voltage \_\_\_\_\_ Cycle \_\_\_\_\_

Phase \_\_\_\_\_

Maximum Fuse Size: \_\_\_\_\_ A

Minimum Wire Ampacity: \_\_\_\_\_ A

© April, 2009 Taylor  
All rights reserved.  
067343-M



*The word Taylor and the Crown design  
are registered trademarks in the United States  
of America and certain other countries.*

Taylor Company  
750 N. Blackhawk Blvd.  
Rockton, IL 61072



# Table of Contents

---

<b>Section 1</b>	<b>To the Installer</b> .....	1
	Installer Safety .....	1
	Site Preparation .....	1
	Air Cooled Units .....	2
	Water Connections (Water Cooled Units Only) .....	2
	Electrical Connections .....	2
	Beater Rotation .....	3
	Refrigerant .....	3
<b>Section 2</b>	<b>To the Operator</b> .....	4
<b>Section 3</b>	<b>Safety</b> .....	5
<b>Section 4</b>	<b>Operator Parts Identification</b> .....	7
	H62 Exploded View .....	7
	H63 Exploded View .....	8
	Door and Beater Assembly .....	9
	Accessories .....	10
<b>Section 5</b>	<b>Important: To the Operator</b> .....	11
	Symbol Definitions .....	12
	Power Switch .....	13
	Liquid Crystal Display .....	13
	Consistency Control .....	13
	Reset Mechanism .....	13
	Operating Screen Descriptions .....	14
	Freezer Locks .....	16
	Operator Menu .....	17
<b>Section 6</b>	<b>Operating Procedures</b> .....	22
	Assembly .....	22
	Sanitizing .....	26
	Priming .....	27
	Daily Closing Procedures .....	28

---

Daily Opening Procedures .....	29
Manual Brush Cleaning .....	30
Draining Product From The Freezing Cylinder .....	31
Rinsing .....	32
Hopper Cleaning .....	32
Disassembly .....	33
Brush Cleaning .....	34
<b>Section 7 Important: Operator Checklist .....</b>	<b>35</b>
During Cleaning and Sanitizing .....	35
Troubleshooting Bacterial Count .....	35
Regular Maintenance Checks .....	35
Winter Storage .....	36
<b>Section 8 Troubleshooting Guide .....</b>	<b>37</b>
<b>Section 9 Parts Replacement Schedule .....</b>	<b>42</b>
<b>Section 10 Parts List .....</b>	<b>43</b>
Wiring Diagrams .....	53

**Note: Continuing research results in steady improvements; therefore, information in this manual is subject to change without notice.**

**Note: Only instructions originating from the factory or its authorized translation representative(s) are considered to be the original set of instructions.**

© April, 2009 Taylor (Original Publication)  
(Updated April, 2012)  
All rights reserved.  
067343-M



*The word Taylor and the Crown design  
are registered trademarks in the United States  
of America and certain other countries.*

Taylor Company  
750 N. Blackhawk Blvd.  
Rockton, IL 61072

# Section 1

# To the Installer

The following are general installation instructions. For complete installation details, please see the check out card.

## Installer Safety



In all areas of the world, equipment should be installed in accordance with existing local codes. Please contact your local authorities if you have any questions.

Care should be taken to ensure that all basic safety practices are followed during the installation and servicing activities related to the installation and service of Taylor equipment.

- Only authorized Taylor service personnel should perform installation and repairs on the equipment.
- Authorized service personnel should consult OSHA Standard 29CFR1910.147 or the applicable code of the local area for the industry standards on lockout/tagout procedures before beginning any installation or repairs.
- Authorized service personnel must ensure that the proper PPE is available and worn when required during installation and service.
- Authorized service personnel must remove all metal jewelry, rings, and watches before working on electrical equipment.



The main power supply(s) to the freezer must be disconnected prior to performing any repairs. Failure to follow this instruction may result in personal injury or death from electrical shock or hazardous moving parts as well as poor performance or damage to the equipment.

**Note: All repairs must be performed by an authorized Taylor Service Technician.**



This unit has many sharp edges that can cause severe injuries.

## Site Preparation

Review the area the unit is to be installed in before uncrating the unit, making sure that all possible hazards the user or equipment may come into have been addressed.

**For Indoor Use Only:** This unit is designed to operate indoors, under normal ambient temperatures of 70°-75°F (21°-24°C). The freezer has successfully performed in high ambient temperatures of 104°F (40°C) at reduced capacities.



This unit must **NOT** be installed in an area where a water jet or hose can be used. **NEVER** use a water jet or hose to rinse or clean the unit. Failure to follow this instruction may result in electrocution.



This unit must be installed on a level surface to avoid the hazard of tipping. Extreme care should be taken in moving this equipment for any reason. Two or more persons are required to safely move this unit. Failure to comply may result in personal injury or equipment damage.

Uncrate the unit and inspect it for damage. Report any damage to your Taylor Distributor.

This piece of equipment is made in the USA and has USA sizes of hardware. All metric conversions are approximate and vary in size.

## Air Cooled Units

**DO NOT** obstruct air intake and discharge openings:

Air cooled units require a minimum of 6" (152 mm) of clearance around all sides of the freezer and 7-1/2" (191 mm) on the bottom to allow for adequate air flow across the condenser. Failure to allow adequate clearance can reduce the refrigeration capacity of the freezer and possibly cause permanent damage to the compressor.

## Water Connections

**(Water Cooled Units Only)**

An adequate cold water supply must be provided with a hand shut-off valve. On the underside rear of the base pan, two 3/8" I.P.S. water connections for inlet and outlet have been provided for easy hook-up. 1/2" inside diameter water lines should be connected to the machine. (Flexible lines are recommended, if local codes permit.) Depending on local water conditions, it may be advisable to install a water strainer to prevent foreign substances from clogging the automatic water valve. There will be only one water "in" and one water "out" connection. **DO NOT** install a hand shut-off valve on the water "out" line! Water should always flow in this order: first, through the automatic water valve; second, through the condenser; and third, through the outlet fitting to an **open trap drain**.



**A back flow prevention device is required on the incoming water connection side.** Please refer to the applicable National, State, and local codes for determining the proper configuration.

## Electrical Connections

In the United States, this equipment is intended to be installed in accordance with the National Electrical Code (NEC), ANSI/NFPA 70-1987. The purpose of the NEC code is the practical safeguarding of persons and property from hazards arising from the use of electricity. This code contains provisions considered necessary for safety. In all other areas of the world, equipment should be installed in accordance with the existing local codes. Please contact your local authorities.



**FOLLOW YOUR LOCAL ELECTRICAL CODES!**

Each freezer requires one power supply. Check the data label on the freezer for branch circuit overcurrent protection or fuse, circuit ampacity and electrical specifications. Refer to the wiring diagram provided inside of the control box for proper power connections.



**CAUTION: THIS EQUIPMENT MUST BE PROPERLY GROUNDED! FAILURE TO DO SO CAN RESULT IN SEVERE PERSONAL INJURY FROM ELECTRICAL SHOCK!**



This unit is provided with an equipotential grounding lug that is to be properly attached to the rear of the frame by the authorized installer. The installation location is marked by the equipotential bonding symbol (5021 of IEC 60417-1) on both the removable panel and the equipment's frame.



- Stationary appliances which are not equipped with a power cord and a plug or another device to disconnect the appliance from the power source must have an all-pole disconnecting device with a contact gap of at least 3 mm installed in the external installation.
- Appliances that are permanently connected to fixed wiring and for which leakage currents may exceed 10 mA, particularly when disconnected, not used for long periods, or during initial installation, shall have protective devices such as a GFI to protect against the leakage of current, installed by authorized personnel to the local codes.
- Supply cords used with this unit shall be oil-resistant, sheathed flexible cable, not lighter than ordinary polychloroprene or other equivalent synthetic elastomer-sheathed cord (Code designation 60245 IEC 57) installed with the proper cord anchorage to relieve conductors from strain, including twisting, at the terminals and protect the insulation of the conductors from abrasion.

## Beater Rotation



Beater rotation must be clockwise as viewed looking into the freezing cylinder.

**Note: The following procedures must be performed by an authorized Taylor service technician.**

To correct rotation on a three-phase unit, interchange any two incoming power supply lines at freezer main terminal block only.

To correct rotation on a single-phase unit, change the leads inside the beater motor. (Follow the diagram printed on the motor.)

Electrical connections are made directly to the terminal block provided in the main control box mounted on the right hand side of the freezer.

## Refrigerant



In consideration of our environment, Taylor proudly uses only earth friendly HFC refrigerants. The HFC refrigerant used in this unit is R404A. This refrigerant is generally considered non-toxic and non-flammable, with an Ozone Depleting Potential (ODP) of zero (0).

However, any gas under pressure is potentially hazardous and must be handled with caution.

NEVER fill any refrigerant cylinder completely with liquid. Filling the cylinder to approximately 80% will allow for normal expansion.



Refrigerant liquid sprayed onto the skin may cause serious damage to tissue. Keep eyes and skin protected. If refrigerant burns should occur, flush immediately with cold water. If burns are severe, apply ice packs and contact a physician immediately.



Taylor reminds technicians to be cautious of government laws regarding refrigerant recovery, recycling, and reclaiming systems. If you have any questions regarding these laws, please contact the factory Service Department.



**WARNING:** R404A refrigerant used in conjunction with polyolester oils is extremely moisture absorbent. When opening a refrigeration system, the maximum time the system is open must not exceed 15 minutes. Cap all open tubing to prevent humid air or water from being absorbed by the oil.

# Section 2

# To the Operator

The Models H62 and H63 shake freezers have been carefully engineered and manufactured to give you dependable operation. These units, when properly operated and cared for, will produce a consistent, quality product. Like all mechanical products, they will require cleaning and maintenance. A minimum amount of care is necessary if the operating procedures outlined in this manual are followed closely.

This Operator's Manual should be read before operating or performing any maintenance on your equipment.

Your Taylor freezer will NOT eventually compensate for and correct any errors during the set-up or filling operations. Thus, the initial assembly and priming procedures are of extreme importance. It is strongly recommended that personnel responsible for the equipment's operation, both assembly and disassembly, go through these procedures together in order to be properly trained and to make sure that no confusion exists.

In the event you should require technical assistance, please contact your local authorized Taylor Distributor.

**Note:** Warranty is valid only if the parts are authorized Taylor parts, purchased from an authorized Taylor Distributor, and the required service work is provided by an authorized Taylor service technician. Taylor reserves the right to deny warranty claims on equipment or parts if non-approved parts or refrigerant were installed in the machine, system modifications were performed beyond factory recommendations, or it is determined that the failure was caused by neglect or abuse.

**Note: Constant research results in steady improvements; therefore, information in this manual is subject to change without notice.**



If the crossed out wheeled bin symbol is affixed to this product, it signifies that this product is compliant with the EU Directive as well as other similar legislation in effect after August 13, 2005. Therefore, it must be collected separately after its use is completed, and cannot be disposed as unsorted municipal waste.

The user is responsible for returning the product to the appropriate collection facility, as specified by your local code.

For additional information regarding applicable local laws, please contact the municipal facility and/or local distributor.

## Compressor Warranty Disclaimer

The refrigeration compressor(s) on this machine are warranted for the term indicated on the warranty card accompanying this machine. However, due to the Montreal Protocol and the U.S. Clean Air Act Amendments of 1990, many new refrigerants are being tested and developed, thus seeking their way into the service industry. Some of these new refrigerants are being advertised as drop-in replacements for numerous applications. It should be noted that, in the event of ordinary service to this machine's refrigeration system, **only the refrigerant specified on the affixed data label should be used.** The unauthorized use of alternate refrigerants will void your compressor warranty. It will be the owner's responsibility to make this fact known to any technician he employs.

It should also be noted that Taylor does not warrant the refrigerant used in its equipment. For example, if the refrigerant is lost during the course of ordinary service to this machine, Taylor has no obligation to either supply or provide its replacement either at billable or unbillable terms. Taylor does have the obligation to recommend a suitable replacement if the original refrigerant is banned, obsoleted, or no longer available during the five year warranty of the compressor.

The Taylor Company will continue to monitor the industry and test new alternates as they are being developed. Should a new alternate prove, through our testing, that it would be accepted as a drop-in replacement, then the above disclaimer would become null and void. To find out the current status of an alternate refrigerant as it relates to your compressor warranty, call the local Taylor Distributor or the Taylor Factory. Be prepared to provide the Model/Serial Number of the unit in question.



We, at Taylor Company, are concerned about the safety of the operator when he or she comes in contact with the freezer and its parts. Taylor has gone to extreme efforts to design and manufacture built-in safety features to protect both you and the service technician. As an example, warning labels have been attached to the freezer to further point out safety precautions to the operator.



**IMPORTANT - Failure to adhere to the following safety precautions may result in severe personal injury or death. Failure to comply with these warnings may damage the machine and its components. Component damage will result in part replacement expense and service repair expense.**



**DO NOT** operate the freezer without reading this Operator Manual. Failure to follow this instruction may result in equipment damage, poor freezer performance, health hazards, or personal injury.



Per IEC 60335-1 and its part 2 standards, "This appliance is to be used only by trained personnel. It is not intended for use by children or people with reduced physical, sensory, or mental capabilities, or lack of experience and knowledge, unless given supervision or instruction concerning the use of the appliance by a person responsible for their safety."



This unit is provided with an equipotential grounding lug that is to be properly attached to the rear of the frame by the authorized installer. The installation location is marked by the equipotential bonding symbol (5021 of IEC 60417-1) on both the removable panel and the equipment's frame.



**DO NOT** use a water jet to clean or rinse the freezer. Failure to follow these instructions may result in serious electrical shock.



- **DO NOT** operate the freezer unless it is properly grounded.
- **DO NOT** operate the freezer with larger fuses than specified on the freezer data label.
- All repairs must be performed by an authorized Taylor service technician. The main power supplies to the machine must be disconnected prior to performing any repairs.
- Cord Connected Units: Only Taylor authorized service technicians may install a plug on this unit.
- Stationary appliances which are not equipped with a power cord and a plug or another device to disconnect the appliance from the power source must have an all-pole disconnecting device with a contact gap of at least 3 mm installed in the external installation.
- Appliances that are permanently connected to fixed wiring and for which leakage currents may exceed 10 mA, particularly when disconnected, not used for long periods, or during initial installation, shall have protective devices such as a GFI to protect against the leakage of current, installed by authorized personnel to the local codes.
- Supply cords used with this unit shall be oil-resistant, sheathed flexible cable, not lighter than ordinary polychloroprene or other equivalent synthetic elastomer-sheathed cord (Code designation 60245 IEC 57) installed with the proper cord anchorage to relieve conductors from strain, including twisting, at the terminals and protect the insulation of the conductors from abrasion.

Failure to follow these instructions may result in electrocution. Contact your local authorized Taylor Distributor for service.



- **DO NOT** allow untrained personnel to operate this machine.
- **DO NOT** operate the freezer unless all service panels and access doors are restrained with screws.
- **DO NOT** remove any internal operating parts (examples: freezer door, beater, scraper blades, etc.) unless all control switches are in the OFF position.

Failure to follow these instructions may result in severe personal injury to fingers or hands from hazardous moving parts.



This unit has many sharp edges that can cause severe injuries.

- **DO NOT** put objects or fingers in the door spout. This may contaminate the product and cause severe personal injury from blade contact.
- **USE EXTREME CAUTION** when removing the beater assembly. The scraper blades are very sharp.



This freezer must be placed on a level surface. Failure to comply may result in personal injury or equipment damage.



**DO NOT** draw product or attempt to disassemble the unit during the HEAT cycle. The product is hot and under extreme pressure.



Cleaning and sanitizing schedules are governed by your state or local regulatory agencies and must be followed accordingly. Please refer to the cleaning section of this manual for the proper procedure to clean this unit.

**DO NOT** obstruct air intake and discharge openings:

Air cooled units require a minimum of 6" (152 mm) of clearance around all sides of the freezer and 7-1/2" (191 mm) on the bottom to allow for adequate air flow across the condenser. Failure to allow adequate clearance can reduce the refrigeration capacity of the freezer and possibly cause permanent damage to the compressor.

**For Indoor Use Only:** This unit is designed to operate indoors, under normal ambient temperatures of 70° - 75°F (21° - 24°C). The freezer has successfully performed in high ambient temperatures of 104°F (40°C) at reduced capacities.

**NOISE LEVEL:** Airborne noise emission does not exceed 78 dB(A) when measured at a distance of 1.0 meter from the surface of the machine and at a height of 1.6 meters from the floor.

# Section 4

# Operator Parts Identification

## H62 Exploded View

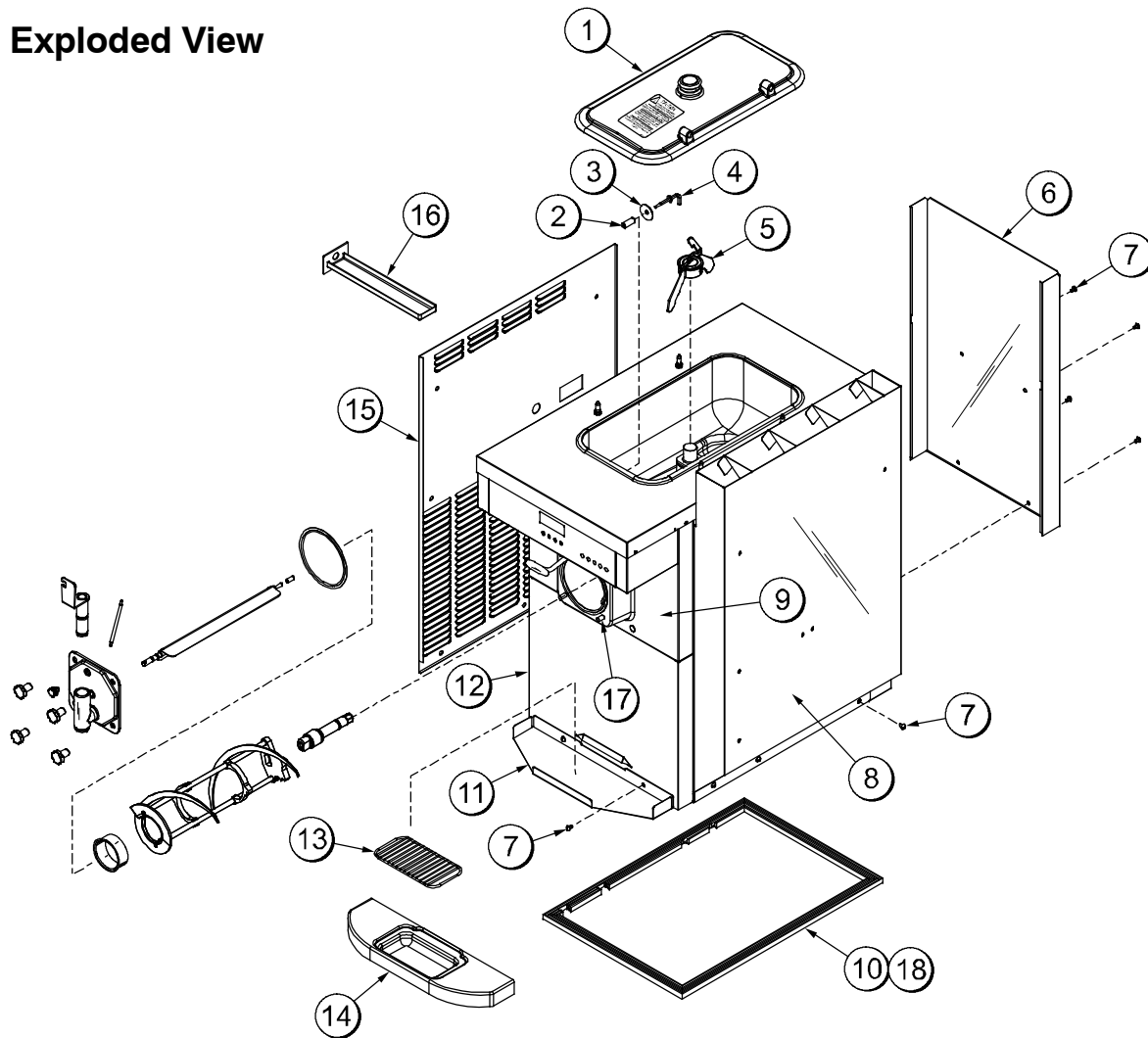

Figure 1

ITEM	DESCRIPTION	PART NO.
1	KIT A.-COVER-HOPPER	X65368
2	SPACER-PROBE *SQ HOLE*	030966
3	DISC-PROBE *SQ HOLE*	030965
4	PROBE A.-MIX LOW-HT	X42077
5	BLADE A.-AGITATOR	X56591-SP1
6	PANEL-REAR	067501
7	SCREW-1/4-20X3/8 SLTD	011694
8	PANEL A.-DUCT-RIGHT	X67499-SP1
9	PANEL-FRONT-UPPER	067305

ITEM	DESCRIPTION	PART NO.
10	GASKET-BASE PAN	067316
11	SHELF-TRAY-DRIP	056076
12	PANEL A.-FRONT-LOWER	X69419
13	SHIELD-SPLASH	049203
14	TRAY-DRIP	056858
15	PANEL-SIDE LEFT	067500-SP1
16	PAN-DRIP 11-5/8 LONG	027503
17	STUD-NOSE CONE	011390
*18	SCREW-10X7/16 UNSLOTTED	066234

\*NOT SHOWN

# H63 Exploded View

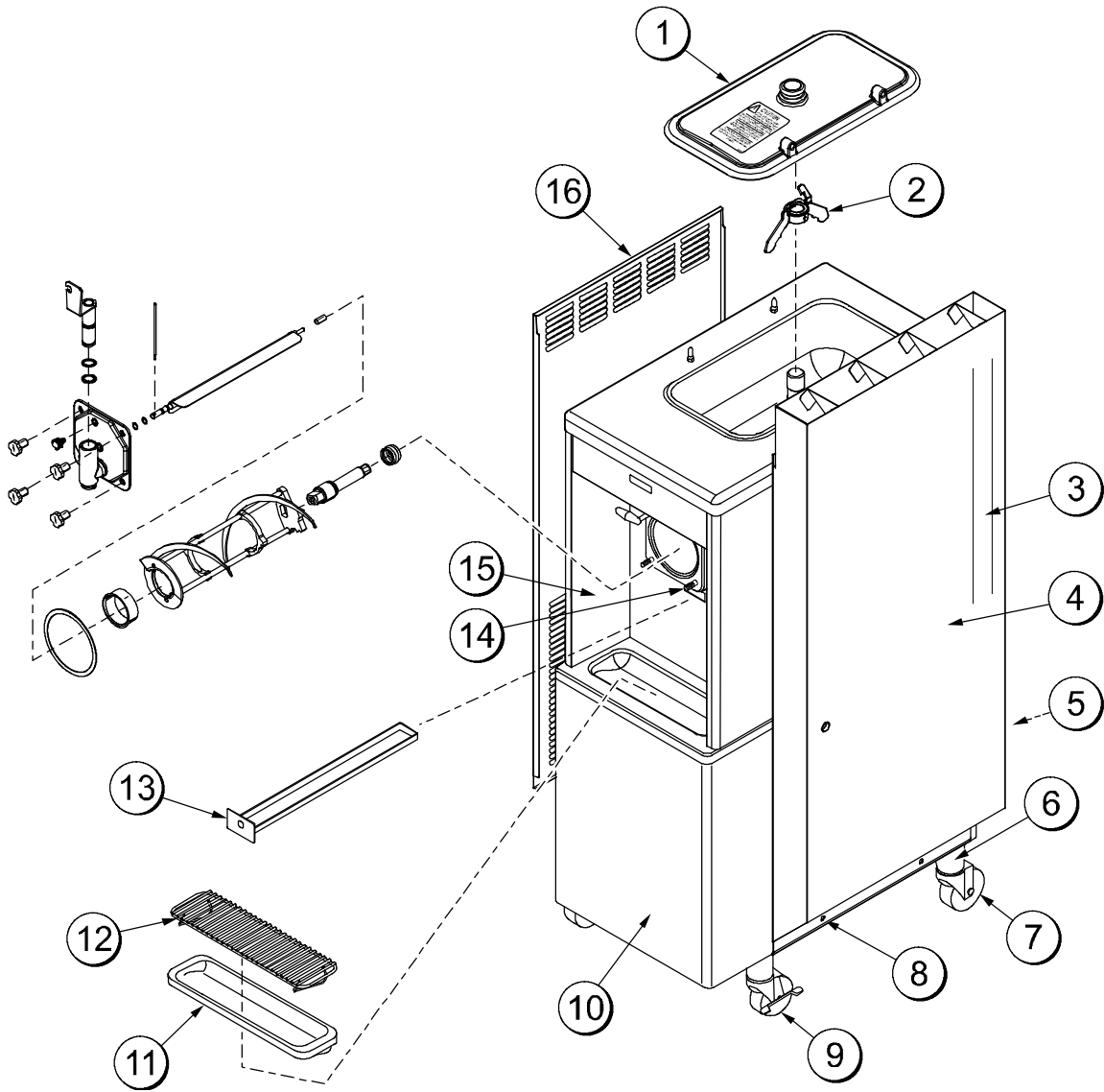

Figure 2

ITEM	DESCRIPTION	PART NO.
1	KIT A.-COVER-HOPPER	X65369
2	BLADE A.-AGITATOR	X56591-SP1
3	TRIM-REAR CORNER	046668
4	PANEL A.-DUCT-RIGHT	X67958-SP1
5	PANEL-REAR W/LOUVERS	026980-SP
6	ADAPTOR A.-CASTER	X18915
7	CASTER-SWV 5/8 STEM 4IN	018794
8	SCREW-1/4-20X5/8	005542
9	CASTER-4" SWV 5/8 STEM W/BRAKE	034081

ITEM	DESCRIPTION	PART NO.
10	PANEL-SERVICE	048380
11	TRAY-DRIP 14.8	046275
12	SHIELD-SPLASH-WIRE 13-11/16 L	046177
13	PAN-DRIP 19-1/2 LONG	035034
14	STUD-NOSE CONE 5/16-18X3/8-1	011390
15	PANEL A.-FRONT	X48371
16	PANEL-SIDE LEFT	067721-SP1

# Door and Beater Assembly

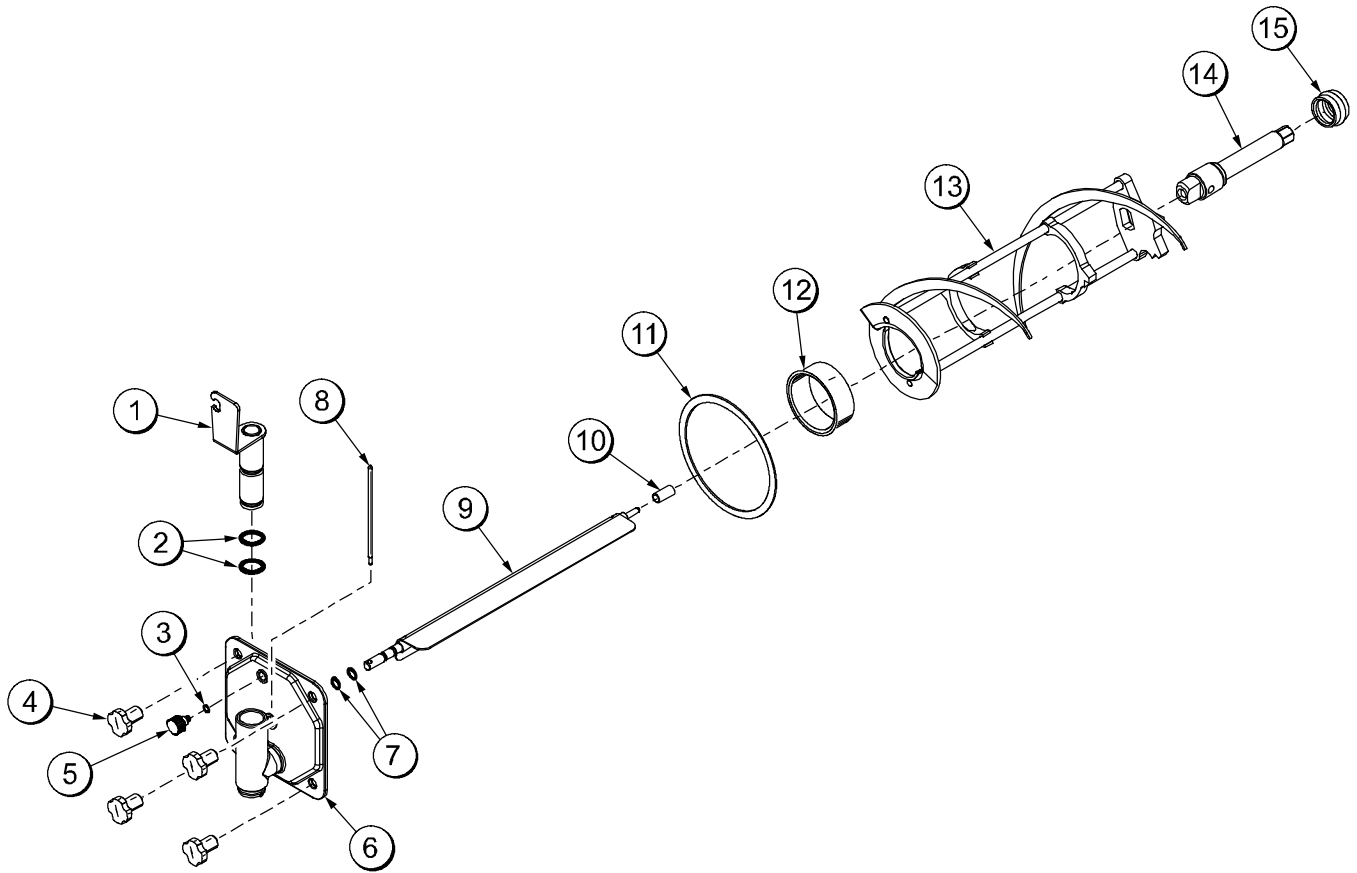

Figure 3

ITEM	DESCRIPTION	PART NO.
1	VALVE A.-DRAW	X56119
2	O-RING-1-1/16 OD X .139W	020571
3	O-RING 5/8 OD X .103 W	016030
4	NUT-STUD	021508
5	PLUG-PRIME	067192
6	DOOR A.-1 SPOUT	X67194-SER
7	O-RING-.291 ID X .080W	018550
8	ARM-TORQUE	067428

ITEM	DESCRIPTION	PART NO.
9	TORQUE A.-SOFT SLUSH	X67190
10	BEARING-GUIDE	014496
11	GASKET-DOOR 5.177 ID	016672
12	BEARING-FRONT	013116
13	BEATER A.-7QT BLADELESS	X45719
14	SHAFT-BEATER <b>H62</b>	067489
	SHAFT-BEATER <b>H63</b>	035527
15	SEAL-DRIVE SHAFT	032560

## Accessories

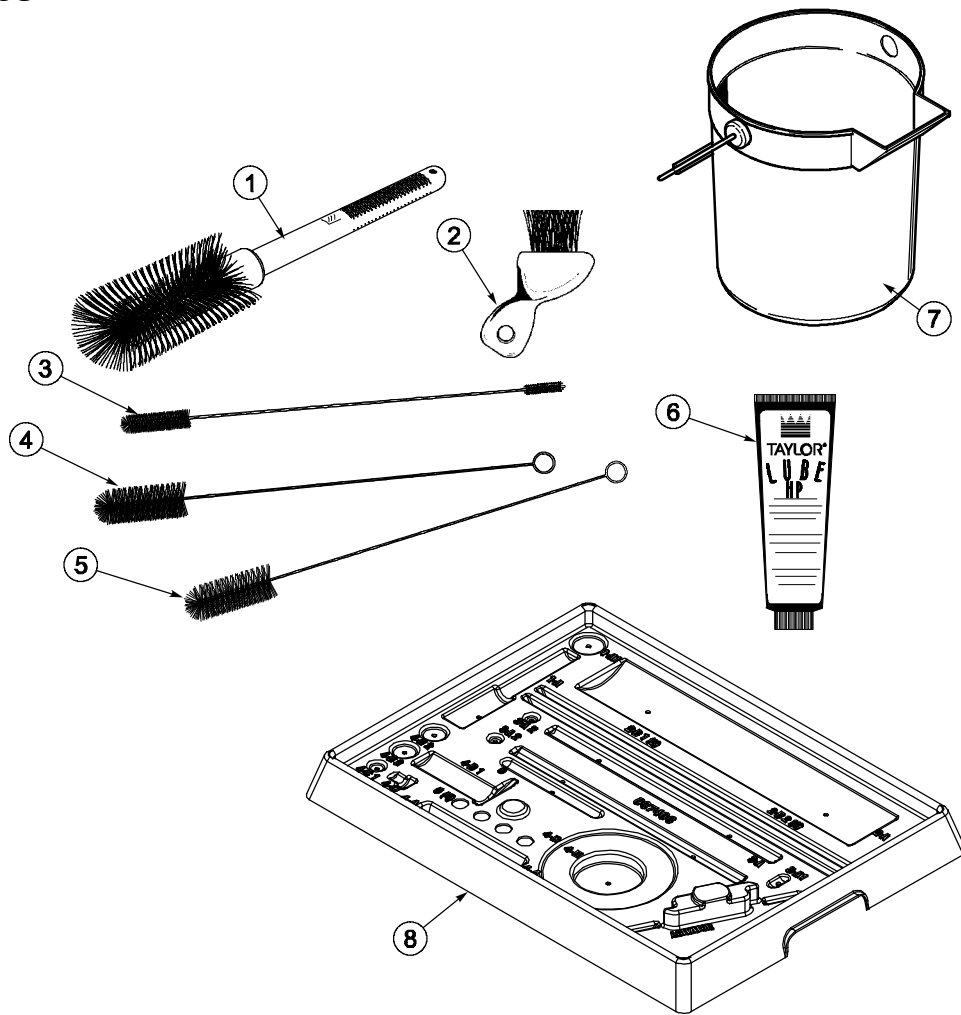

Figure 4

ITEM	DESCRIPTION	PART NO.
1	BRUSH-MIX PUMP BODY - 3" X 7" WHITE	023316
2	BRUSH-END-DOOR-SPOUT	039719
3	BRUSH-DOUBLE ENDED	013072
4	BRUSH-REAR BRG 1IN.D X 2IN	013071
5	BRUSH-DRAW VALVE	014753

ITEM	DESCRIPTION	PART NO.
6	LUBRICANT-TAYLOR HI PERF	048232
7	PAIL-MIX 10 QT.	013163
8	TRAY-PARTS-BARREL 7 QT.	067406
*	KIT A.-TUNE UP	X67224
**	SANITIZER-STERA SHEEN	SEE NOTE

\*Not Shown

**\*\*Note:** A sample container of sanitizer is sent with the unit. For reorders, order Stera Sheen part no. 055492 (100 2 oz. packs) or Kay-5 part no. 041082 (200 packs).

# Section 5

# Important: To the Operator

H62

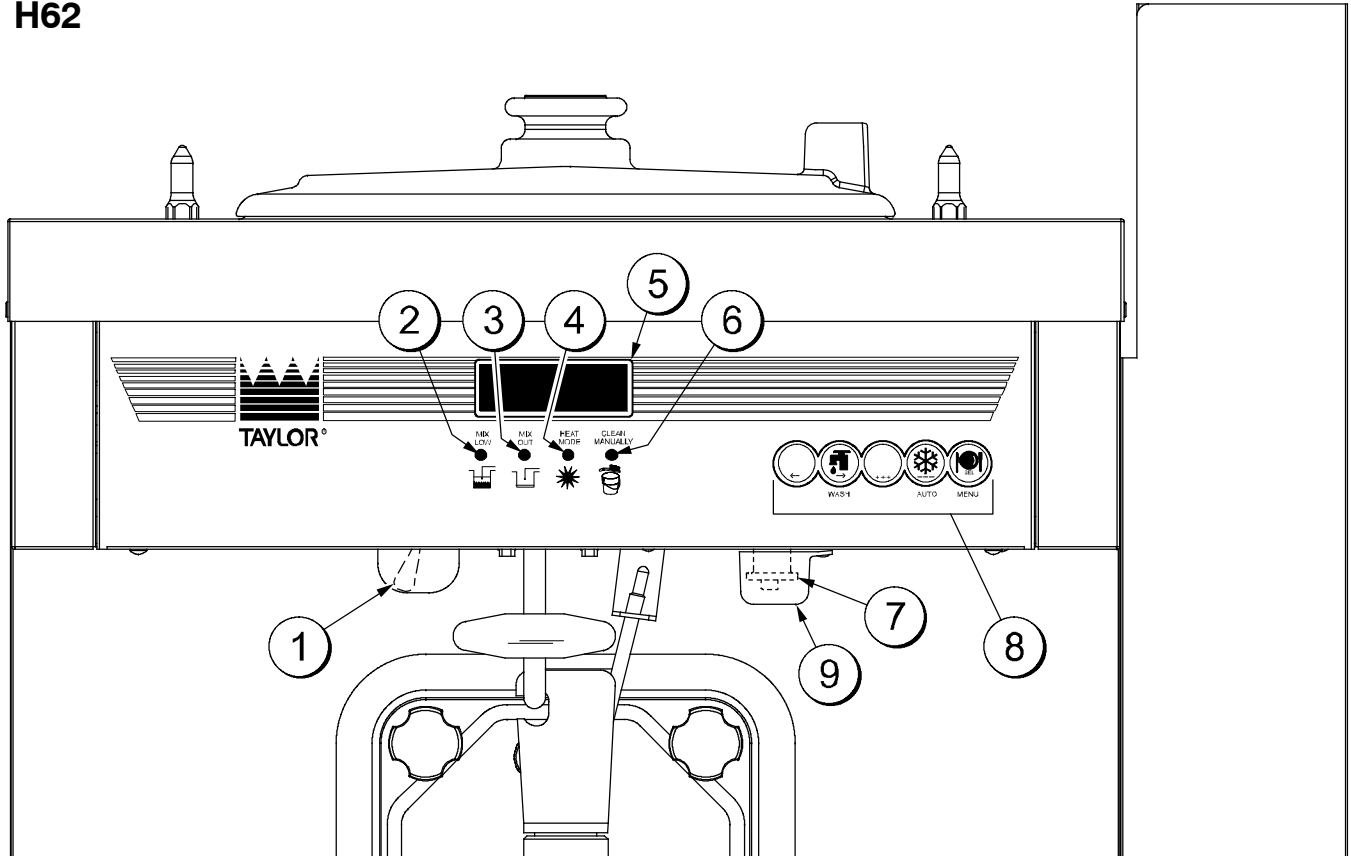

Figure 5

ITEM	DESCRIPTION
1	POWER SWITCH (TOGGLE)
2	LED INDICATOR-MIX LOW (PCB A-LED)
3	LED INDICATOR-MIX OUT (PCB A-LED)
4	LED INDICATOR-HEAT MODE
5	LIQUID CRYSTAL DISPLAY

ITEM	DESCRIPTION
6	LED INDICATOR- CLEAN MANUALLY
7	CONSISTENCY CONTROL (SWITCH-TORQUE)
8	KEYPADS
9	COVER-VISCOSITY ADJUSTMENT

# H63

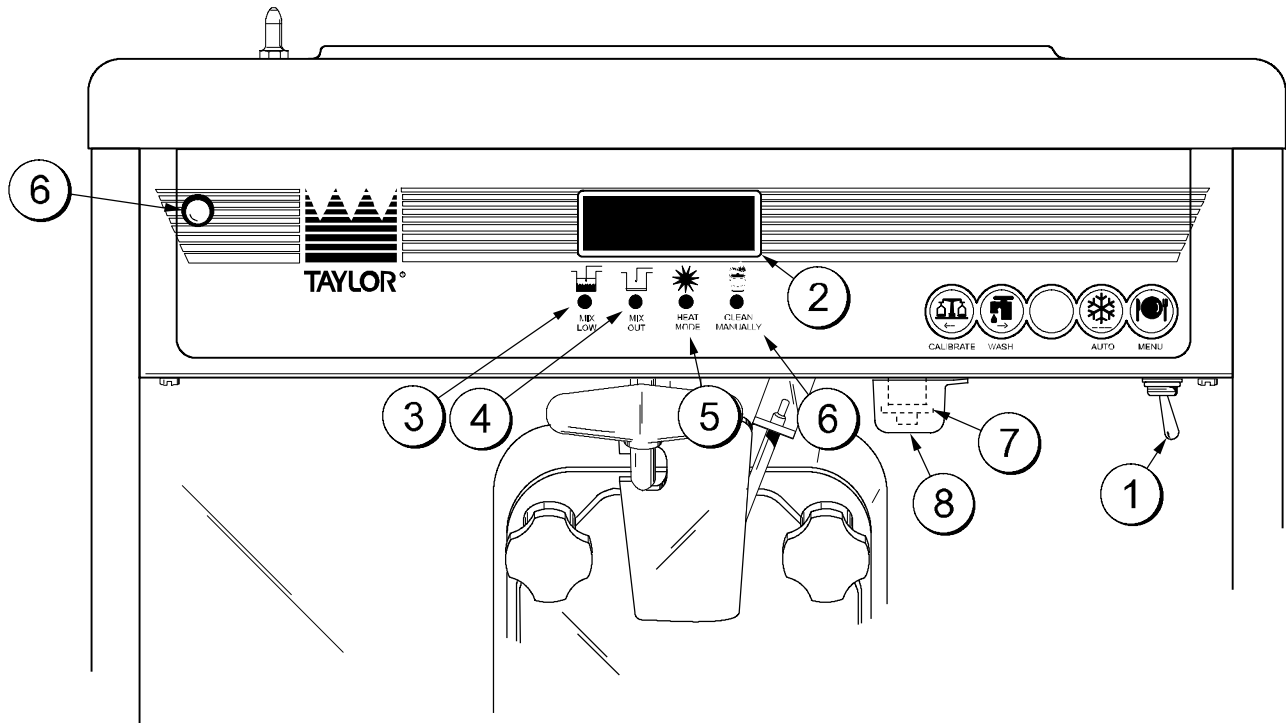











Figure 6

ITEM	DESCRIPTION
1	POWER SWITCH (TOGGLE)
2	LIQUID CRYSTAL DISPLAY
3	LED INDICATOR-MIX LOW (PCB A-LED)
4	LED INDICATOR-MIX OUT (PCB A-LED)
5	LED INDICATOR-HEAT MODE
6	LED INDICATOR-CLEAN MANUALLY
7	CONSISTENCY CONTROL (SWITCH-TORQUE)
8	COVER-VISCOSITY ADJUSTMENT

The following chart identifies the symbol definitions used on the operator switches.

-  = ON
-  = OFF
-  = MIX LOW
-  = MIX OUT
-  = HEAT MODE
-  = CLEAN MANUALLY
-  = WASH
-  = AUTO
-  = MENU

## Symbol Definitions

To better communicate in the International arena, the words on many of our operator switches and buttons have symbols to indicate their functions. Your Taylor equipment is designed with these International symbols.



## Power Switch

When placed in the ON position, the power switch allows control panel operation. The power switch is located on the left side of the control channel.

## Liquid Crystal Display

The Liquid Crystal Display (LCD) is located on the front control panel. The LCD is used to show the current mode of operation, and whether or not there is sufficient mix.

## LED Indicator - MIX LOW

The MIX LOW indicator flashes to indicate that the mix hopper has a low supply of mix. The mix hopper should be filled as soon as possible.

## LED Indicator - MIX OUT

The MIX OUT indicator flashes to indicate that the mix hopper has an insufficient supply of mix to operate the freezer. At this time, the AUTO mode is locked out and the freezer goes into the STANDBY mode. To return the freezer to the AUTO mode, fill the hopper with mix and press the AUTO key. The freezer will automatically begin operation.

## LED Indicator - HEAT MODE

The HEAT MODE indicator flashes to indicate that the freezer is in the process of a heat cycle.

## LED Indicator - CLEAN MANUALLY

The CLEAN MANUALLY indicator flashes to indicate that the freezer must be disassembled and brush cleaned within 24 hours.

When all four indicators are flashing, the freezer is in a locked condition. Once a hard lock condition has been remedied, two indicators will remain flashing until the mix low and mix out conditions have been satisfied. During a soft lock condition, all four indicators will stop flashing once the unit has been placed in a heat cycle.

## Consistency Control

The viscosity (thickness) of the shake is controlled by a sensing device called the consistency control. The consistency control knob is located to the lower right of the control channel. To achieve a thicker shake, turn the knob clockwise and counterclockwise to achieve a thinner shake consistency.

Allow the refrigeration system to cycle on and off 2 or 3 times before an accurate consistency can be evaluated.

## Reset Mechanism

The reset button is located in the left side panel of the H62. The reset button is located in the right side panel of the H63. The reset mechanism protects the beater motor from an overload condition. If an overload occurs, the reset mechanism will trip. To properly reset the freezer, press the reset button firmly and clear the tone per instructions in "Clearing Fault Tones" on page 18.

If the reset mechanism trips again, contact your authorized Taylor Distributor to resolve the problem.



**Warning: Do not use metal objects to press the reset button. Failure to comply may result in severe personal injury or death.**

## Operating Screen Descriptions

When the machine is powered the system will initialize. The screen will display "INITIALIZING". There will be four types of data the system will check: LANGUAGE, SYSTEM DATA, CONFIG DATA, and LOCKOUT DATA. During the INITIALIZING... LANGUAGE screen, the alarm will be on. If the system data, configuration data, or lockout history data has become corrupt, the following screen will alert the operator that the system settings may have been changed.

**NVRAM FAULT  
RESET TO DEFAULTS  
PRESS SEL KEY**

Once the system has initialized the SAFETY TIMEOUT screen is displayed and the alarm is turned on.

**SAFETY TIMEOUT  
ANY KEY ABORTS**

This screen will be displayed, with the alarm on, for 60 seconds or until any key is pressed.

After the safety timeout has been completed, and the power switch is OFF, one of the following screens is displayed.

The first screen is displayed if the machine is not in a brush clean state.

	<b>POWER SWITCH OFF</b>
<b>MIX: OUT</b>	<b>TIME: 4:30</b>
<b>HOPPER: 62.1</b>	
<b>BARREL: 67.7</b>	

If any of the requirements for a brush clean have not been met, the time displayed will remain at 5:00 minutes. When all the requirements for a brush cleaning are met, and the five minutes expire, the screen will change to the second screen, which is the standard power switch OFF screen.

**POWER SWITCH OFF**  
- - - - -  
**UNIT CLEANED**

When the power switch is set in the ON position, the system mode of operation screen is displayed. In this example, the machine is ON, but no mode of operation has been selected. The second line of the display indicates whether there is a sufficient supply of mix in the hopper or if there is a LOW or OUT mix condition. The third line of the display shows the temperature of the mix hopper. After pressing the AUTO key, the last line of the display shows the month and date (MM = month, DD = day) that the machine needs to be disassembled and brush cleaned.

**MODE: ON  
MIX: OK  
HOPPER TEMP: 40.0F  
BRUSH CLEAN ON: MM/DD**

The next display indicates the freezer is operating in two different modes. The following information is given:

The machine is operating in the WASH mode and the mix level in the hopper is low. The temperature of the mix hopper is 40°F (4.4°C), and the machine needs to be brush cleaned on October 31st.

**MODE: WASH  
MIX: LOW  
HOPPER TEMP: 40.0 F  
BRUSH CLEAN ON: 10/31**

**The following displays pertain to the HEAT cycle:**

A System Alert screen displays an alert and alarm 15 minutes prior to the start of the heat cycle. The alarm will sound and show on the display. The alarm will sound until the SEL key is pressed to clear the fault. This feature allows the operator time to make sure the freezer is in AUTO or STANDBY, and has the proper amount of mix in the hopper before the start of the heat cycle.

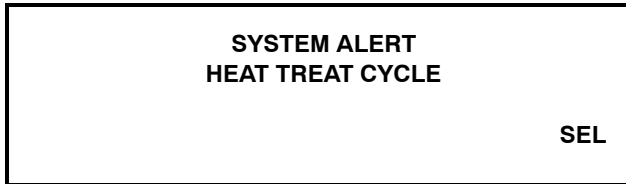

While in the heating phase, you will see this display. It shows the present temperature of the hopper.

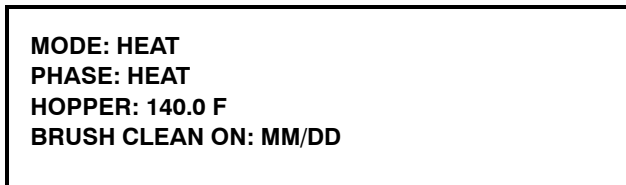

During the heating phase, the mix temperature must be raised above 151°F (66.1°C) within 90 minutes or the freezer will be locked in STANDBY, and the cycle failure display will appear.

In the example, the hopper temperature is 140°F (60°C). The phase shows that the machine is in the heat phase of the heat treatment cycle.

When the heating phase is complete, the freezer goes into the holding phase of the cycle. The holding phase will hold the temperature above 151°F (66.1°C) for a minimum of 30 minutes.

In this example, the hopper temperature is 151°F (66.1°C).

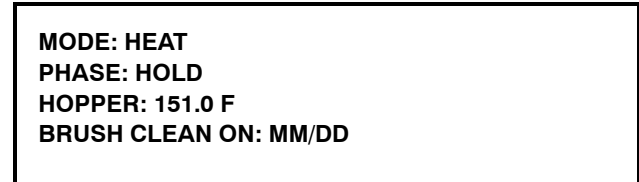

The final phase of the heat treatment cycle is the cooling phase. Now the freezer must cool the mix below 41°F (5°C). If the product fails to cool in two hours, the freezer will lock out.

This example illustrates that the temperature is being lowered, but has not yet reached the set point.

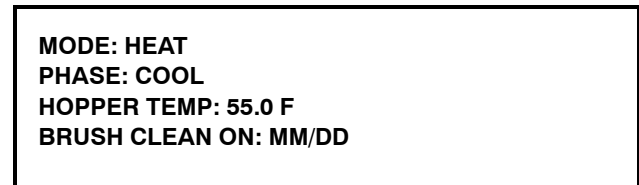

The entire heat treatment cycle must be completed in four hours.

When the entire heat cycle has been completed, the normal display will appear, showing the machine in the STANDBY mode. The machine may now be placed in the AUTO mode or left in the STANDBY mode.

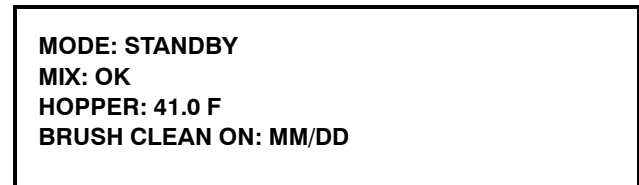

## Freezer Locks

There are two types of freezer lock conditions that can occur: Hard Lock or Soft Lock. A Hard Lock requires that the machine be disassembled and brush cleaned. A Soft Lock can be corrected by either disassembling and brush cleaning the machine or by starting another heat treatment cycle.

**Hard Lock:** There are two causes for a hard lock. The freezer will hard lock if either the Brush Clean Timer has elapsed or if a Thermistor Failure (freezing cylinder or hopper) occurred during a Heat Cycle.

1. The following screen will be displayed if a Brush Clean Cycle Time has occurred.

BRUSH CLEAN TIMEOUT  
FREEZER LOCKED  
CLEANING REQ'D  
> BRUSH CLEAN

Touching the MENU/SEL key will display the following screen.

FREEZER LOCKED

2. The following screen will display if there has been a thermistor failure (freezing cylinder or hopper) during the heat treatment process.

SYSTEM FAULT  
FREEZER LOCKED  
SERVICE REQ'D  
> BRUSH CLEAN

All four LED's on the front of the freezer will light. Press the MENU/SEL key.

The next display is the screen which will appear after the failure message. To comply with health codes, heat treatment system freezers **must** complete a heat treatment cycle daily, and **must** also be brush cleaned every 14 days. Brush cleaning is the normal disassembly and cleaning procedures. Failure to follow these guidelines will cause the control to lock the freezer out of the AUTO mode.

Press the WASH key.

NO AUTO OPERATION  
ALLOWED UNTIL  
BRUSH CLEANING  
PRESS WASH KEY

**Note:** The heat treatment schedule can be adjusted from 2 to 14 days. Always comply with local guidelines for the maximum number of days allowed between brush clean cycles.

The next display will appear after the brush cleaning message. It indicates that the control is in the OFF mode and the machine needs to be disassembled and brush cleaned.

MODE: OFF  
MIX: OK  
HOPPER TEMP: 41.0 F  
FREEZER LOCKED

Once the unit is unlocked, only the MIX OUT and MIX LOW LED's will flash.

**Soft Lock:** If a heat treatment cycle has not been **initiated** within the last 24 hours, all four LED's on the front of the machine will light and a message will appear on the LCD. Line 3 of the LCD will indicate the reason the message appears.

NO HEAT TREAT START  
BECAUSE  
VARIABLE MESSAGE  
PRESS SEL KEY

Following are the variable messages which will appear on line 3:

1. **POWER SWITCH OFF:** Power switch was in the OFF position.
2. **MIX OUT PRESENT:** There was a mix out condition present.
3. **AUTO OR STANDBY OFF:** The unit was not in the AUTO or STANDBY mode.
4. **NO HEAT CYCLE TRIED:** A heat treatment cycle was not attempted in the last 24 hours. (AUTO HEAT TIME was advanced, or a power loss was experienced at the time the cycle was to occur, or a heat cycle failure not due to a thermistor failure.)

If the following screen appears, a soft lock has occurred **during** the heat treatment cycle.

**HEAT TREAT CYCLE  
FAILURE  
FREEZER LOCKED  
PRESS SEL KEY**

If the temperature of the product has not fallen below 41°F (5°C) by the end of the COOL cycle, the following screen will appear.

**PRODUCT OVER TEMP  
FREEZER LOCKED  
PRESS SEL KEY**

Press the MENU/SEL key to advance to the next display.

When one of these messages appears, automatic freezer operation cannot take place until the freezer is disassembled and brush cleaned or has completed a heat treatment cycle.

The next display will instruct the operator to start a heat treatment cycle manually (by pressing the AUTO key), or to disassemble and brush clean the freezer. If the AUTO key is pressed, the freezer will automatically start the heat treatment cycle and only the heat cycle LED will light.

**NO AUTO OPERATION  
ALLOWED. PRESS  
AUTO FOR HEAT CYCLE  
WASH TO BRUSH CLEAN**

If the WASH key is pressed, the next display will appear and the freezer will have to be disassembled and brush cleaned.

**MODE: OFF  
MIX: OK  
HOPPER TEMP: 41.0F  
FREEZER LOCKED**

Once the freezer is unlocked by starting a heat treatment cycle, only the heat cycle LED will light. If the freezer is unlocked by brush cleaning, the mix low and mix out LED's will light.

## Operator Menu

Screen "A" is the OPERATOR MENU. It is used to enter the operator function displays. To access the OPERATOR MENU, simply press the MENU/SEL key. The cursor will flash over the letter "A" indicating that this is screen "A". To select a different screen, use the arrow keys and move the cursor to the desired screen selection and press the MENU/SEL key.

**OPERATOR MENU**  
**A B C D E F G H I J K L M N**  
**EXIT FROM MENU**  
-< - - - - -> **SEL**

Screen "B" is FAULT DESCRIPTION. The fault description will indicate if there is a fault with the freezer.

**FAULT DESCRIPTION**  
**VARIABLE MESSAGE**  
**CLR** **SEL**

## Clearing Fault Tones

To clear the tone for any faults which have been corrected, press the <- - arrow key. To see if there is more than one fault, press the MENU/SEL key. When the last fault is displayed, the control will return to the OPERATOR MENU. To return to the main screen, move the cursor to "A" and press the MENU/SEL key again.

Listed below are the variable messages which will appear, along with the corrective action:

1. **NO FAULT FOUND:** There was no fault found in the freezer. Nothing will appear on the screen after this variable message appears.
2. **BEATER OVERLOAD:** Press the reset button firmly and clear the tone .
3. **HPCO COMPRESSOR:** Place the power switch in the OFF position. Wait 5 minutes for the machine to cool. Place the power switch in the ON position and clear the tone.
4. **COMP ON TOO LONG:** Place the power switch in the OFF position and clear the tone. Call service technician.
5. **HOPPER THERM BAD:** Place the power switch in the OFF position. Call service technician.
6. **BARREL THERM BAD:** Place the power switch in the OFF position. Call service technician.
7. **GLYCOL THERM BAD:** Place the power switch in the OFF position. Call service technician.
8. **HOPPER OVER TEMP:** The hopper temperature has risen too high as follows. Clear the tone.
  - a. The hopper temperature was 41°F (5°C) or higher for four hours.
  - b. The hopper temperature was 45°F (7°C) or higher for more than one hour.
9. **BARREL OVER TEMP:** The barrel temperature has risen too high as follows. Clear the tone.
  - a. The barrel temperature was 41°F (5°C) or higher for four hours.
  - b. The barrel temperature was 45°F (7°C) or higher for more than one hour.
10. **POWER FAILURE:** This message will appear in the FAULT DESCRIPTION if a power failure has occurred. Clear the tone.

Screen "C" is SET CLOCK. This screen will display the current date and time. The date and time may only be changed after the freezer has been manually brush cleaned but before it has been placed in the AUTO mode. Move the cursor under the number you wish to change. Press the plus key to increase the number; press the minus key to decrease the number. When the desired time and date appears, press the MENU/SEL key once to return to the OPERATOR MENU.

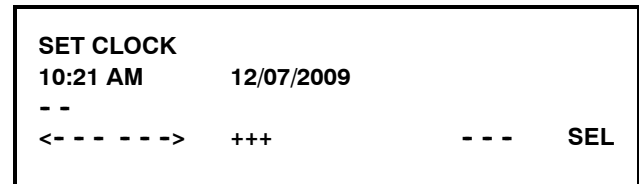

If an invalid date is entered, the following screen will appear.

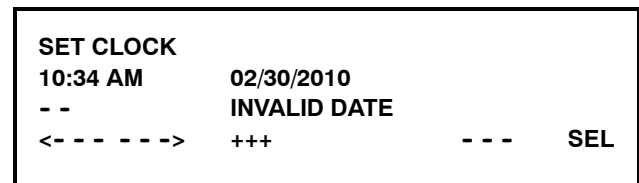

When the MENU/SEL key is pressed, the controller will return to the previous LCD screen to allow for correction of the calendar entry. The controller will not advance to the next screen until a valid date has been entered. Once a valid date has been entered, pressing the MENU/SEL key will display a the Daylight Saving Time screen.



Pressing the <- - arrow key or the - -> arrow key will move the cursor left or right respectively. Pressing

the MENU/SEL key while under "ENABLE" will accept the selection and will automatically increase the clock one hour at 2:00 a.m. on the first Sunday in every April. It will decrease one hour at 2:00 a.m. on the last Sunday in every October. Pressing the MENU/SEL key while under "DISABLE" will accept the selection and operate normally. Pressing the MENU/SEL key again will accept the selection and return to the OPERATOR MENU.

Screen "D" is SYSTEM INFORMATION. The first screen will indicate the software version used in the unit.

<b>SOFTWARE VERSION</b> <b>H63 Control UVC2</b> <b>Version X.XX</b>	<b>SEL</b>
---	------------

Press the MENU/SEL key to view the second screen of the SYSTEM INFORMATION display. This screen will indicate the version number and number of language strings.

<b>Language</b> <b>V1.10r00</b>	<b>English</b>	<b>457</b>
		<b>SEL</b>

Press the MENU/SEL key to view the third screen of the SYSTEM INFORMATION display. This screen will indicate the Bill of Material number and serial number for the unit. Press the MENU/SEL key once to return to the Operator Menu.

<b>B.O.M.</b> <b>S/N</b>	<b>0H6333C000</b> <b>K0000000</b>	<b>SEL</b>
-----------------------------	--------------------------------------	------------

Screen "E" is AUTO HEAT TIME. This screen is used to set the time of day in which the heat treatment cycle will start. Move the cursor under the number you wish to change. Press the plus key to increase the number; press the minus key to decrease the number. When the desired time appears, press the MENU/SEL key once to return to the OPERATOR MENU.

<b>AUTO HEAT TIME</b>		
<b>TIME: 12:00 AM</b>		
--		
<-- -- -- -->	+++	-- -- <b>SEL</b>

Screen "F" is BRUSH CLEAN CYCLE. This option allows the manager to select the maximum number of days between brush cleanings. The brush clean cycle may only be changed after the freezer has been manually cleaned, but before it has been placed in the AUTO or STANDBY mode.

Screen "G" is CURRENT CONDITIONS. This screen displays the hopper and barrel temperatures. Press the MENU/SEL key once to view the SERVINGS COUNTER screen.

	<b>HOPPER</b>	<b>BARREL</b>
	<b>38.5</b>	<b>28.5</b>
<b>TIME C</b>	<b>11:00</b>	

The SERVINGS COUNTER screen indicates the number of draws since the last brush cleaning or since the last serving counter reset. A maximum of 32,767 draws can be recorded; an additional draw will cause the counter to restart at zero. Pressing the MENU/SEL key will return the display to the Operator Menu.

<b>SERVINGS COUNTER</b>	
<b>DRAWS</b>	
12	
	<b>SEL</b>

Draws are counted during the AUTO mode of operation only.

Screen "H" is HEAT CYCLE DATA. The information from the previous heat treatment cycles can be obtained through this screen. The most recent heat treatment cycle data will be shown first; press the plus key to scroll through the remaining heat cycle displays. If a heat treatment cycle failure should occur, a two character message will appear on the second line of the screen. Press the MENU/SEL key once to return to the OPERATOR MENU.

00:00	00:00	00:00	
HEAT	OVER	COOL	RC
00:00	00:00	00:00	
TEMP AT END		0.0	1

Listed below are the variable messages which could appear:

- HT Failure in the heating phase.
- CL Failure in the cooling phase.
- TT Failure in meeting total heat treatment cycle time requirement.
- MO Mix out condition.
- OP Operator interruption.
- PF Power failure. (If a power failure occurs, but the heat treatment cycle does not fail, an asterisk (\*) will appear on the 3rd line of the display.)
- BO Beater overload.
- HO High pressure cut-out.
- TH Failed thermistor probe.
- PS Power switch placed in the OFF position.
- ML Mix Low Condition.
- 14 14 Day Timeout Occurred.
- RC Heat Cycle Record Cleared.

Pressing the <- - arrow key on any HEAT CYCLE DATA screen will cause the extended data screen to be displayed. This screen shows the hopper, barrel, and glycol temperatures, and the amount of time the freezer spent in the phase of the heat cycle when the heat cycle completed, or was terminated.

HOPPER	BARREL	GLYCOL	
151.0	134.5	178.0	
PHASE TIME: 1:20			1

Screen "I" is the LOCKOUT HISTORY. This screen displays a history of the last 40 hard locks, soft locks, and brush clean dates. Page numbers are indicated in the upper right hand corner. Page 1 always contains the most recent failure. Press the +++ key to cycle through the pages.

The second line of the screen displays the date and time a failure occurs. The third line indicates the reason for a failure, or will indicate a successful brush cleaning has occurred. Some failures occur for multiple reasons. When this occurs, a page will be generated for each reason. Press the MENU/SEL key once to return to the Operator Menu.

LOCKOUT HISTORY			1
12/21/09	02:08		
SOFTLOCK ABORT			
	+++	---	SEL

Screen "J" is the SERVICE MENU. This screen can only be accessed by a service technician.

Screen "K" is the STANDBY MODE. To place the freezer in the STANDBY mode, move the cursor under the word "yes". Press the MENU/SEL key to execute the command. Pressing the MENU/SEL key again will return you to the main screen. To exit the STANDBY mode and place the unit in AUTO, press the AUTO key once. Pressing the AUTO key again will place the unit in the OFF mode.

STANDBY MODE			
STANDBY	YES	NO	
		---	
<--- -->			SEL



Screen "L" is AUTO START TIME. This option allows the manager to set the time of day that the machine automatically enters the AUTO mode from the STANDBY mode. Selecting this option displays the AUTO START TIME Enable/Disable screen. Pressing the <-- key moves the cursor under the ENABLE screen. Pressing the --> key moves the cursor under the DISABLE selection.

```

AUTO START TIME
ENABLE           DISABLE
  ---
<----->           SEL
  
```

Pressing the MENU/SEL key with the cursor under the ENABLE selection displays the following screen.

```

AUTO START TIME
TIME :           12:00 AM
  ---
<----->   +++           ---   SEL
  
```

To change the time, move the cursor under the number to change. Press the + + + key to increase the number. Press the - - - key to decrease the number. When the desired time appears, press MENU/SEL key to accept the setting.

Screen "M" is MIX LEVEL AUDIBLE. This option enables or disables an audible alarm for MIX LOW and MIX OUT conditions. Place the cursor under the desired selection by using the arrow keys. Press MENU/SEL to accept the setting.

```

MIX LEVEL AUDIBLE
ENABLE           DISABLE
  ---
<----->           SEL
  
```

Screen "N" is MANUAL HEAT CYCLE. This option allows a heat cycle to be initiated at any time.

```

MANUAL HEAT CYCLE
YES           NO
  ---
<----->           ---   SEL
  
```

# Section 6

# Operating Procedures

The Models H62 and H63 have 7 quart (6.6 liter) freezing cylinders and offer one flavor.

The Model H63 has been selected to show you the pictured step-by-step operating procedures for both models contained in this manual. These models, for practical purposes of operation, are the same.

We begin our instructions at the point where we enter the store in the morning and find the parts disassembled and laid out to air dry from the previous night's brush cleaning.

These opening procedures will show you how to assemble these parts into the freezer, sanitize them, and prime the freezer with fresh mix in preparation to serve your first shake.

If you are disassembling the machine for the first time or need information to get to this starting point in our instructions, turn to page 33, "Disassembly", and start there.

## Assembly

**Note:** When lubricating parts, use an approved food grade lubricant (example: Taylor Lube HP).



**MAKE SURE THE POWER SWITCH IS IN THE OFF POSITION!** Failure to do so may cause injury from hazardous moving parts, or electrocution.

**Be certain your hands are sanitized before assembling the freezer.**

### Step 1

Lubricate the groove and shaft portion of the beater drive shaft. Slide the drive shaft seal over the shaft and groove until it snaps into place. **DO NOT lubricate the hex end of the drive shaft.**

Fill the inside portion of the seal with 1/4" more lubricant. Lubricate the flat side of the seal that comes in contact with the bearing.

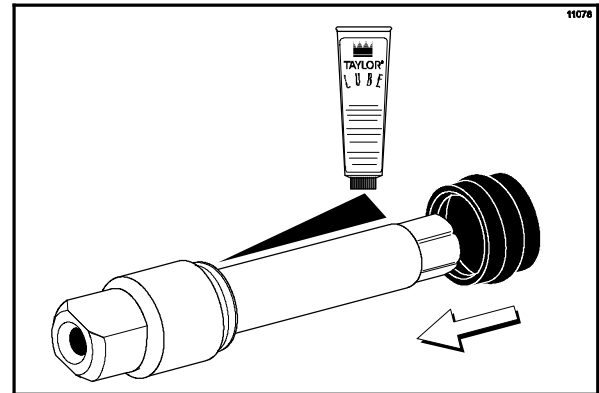

Figure 7

**Note:** Make sure the seal is not installed inside-out. The ridge that protrudes at the center of the seal should be on the **outside**.

### Step 2

Install the drive shaft into the freezing cylinder, hex end first, and into the rear shell bearing until the seal fits securely over the rear shell bearing. Be certain the drive shaft fits into the drive coupling without binding.

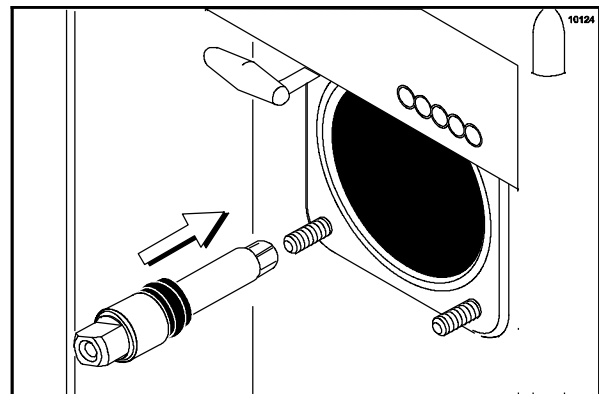

Figure 8

**Note:** After inserting the drive shaft into the freezing cylinder, use a single service paper towel to remove any excess lubricant that was displaced from the drive shaft seal when it was installed onto the rear shell bearing.

### Step 3

Slide the beater into the freezing cylinder.

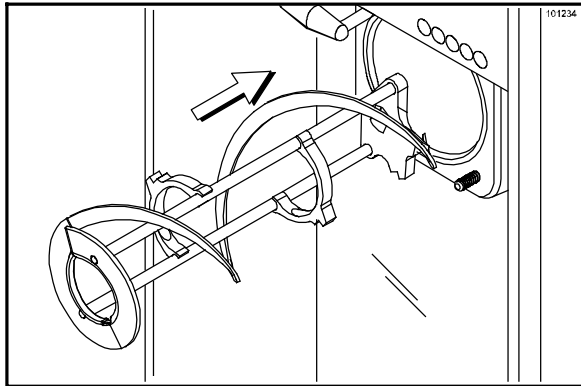

Figure 9

### Step 4

Make sure the beater assembly is in position over the drive shaft. Turn the beater slightly to be certain that the beater is properly seated. When in position, the beater will not protrude beyond the front of the freezing cylinder.

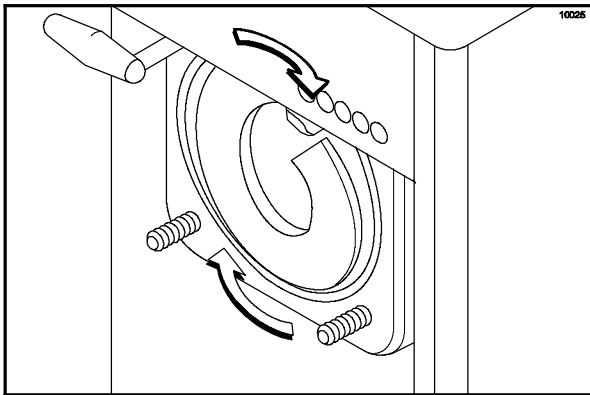

Figure 10

### Step 5

Assemble the torque rotor by sliding the two o-rings on the front of the shaft and lubricate them thoroughly to prevent leaking. Place the white plastic guide bearing on the rear of the rotor shaft. **DO NOT** lubricate the plastic guide bearing.

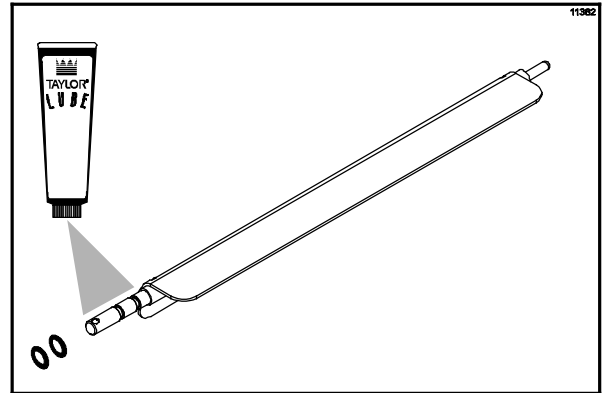

Figure 11

### Step 6

Insert the torque rotor, plastic guide bearing end first, **making sure** that it fits into the hole in the beater drive shaft. Rotate it several times to check for proper positioning.

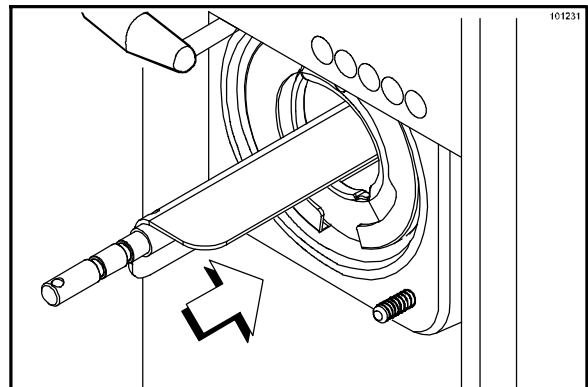

Figure 12

**Step 7**

Slide the two o-rings onto the draw valve and lubricate.

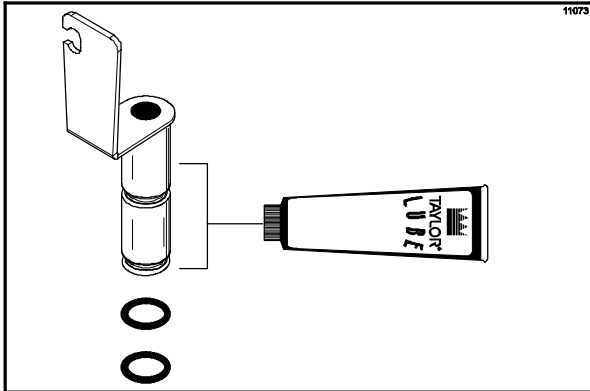

Figure 13

**Step 8**

Lubricate the inside of the door spout, top and bottom. Insert the draw valve into the freezer door from the top. It will be necessary to rotate the draw valve bracket to the right to allow installation of door on freezer.

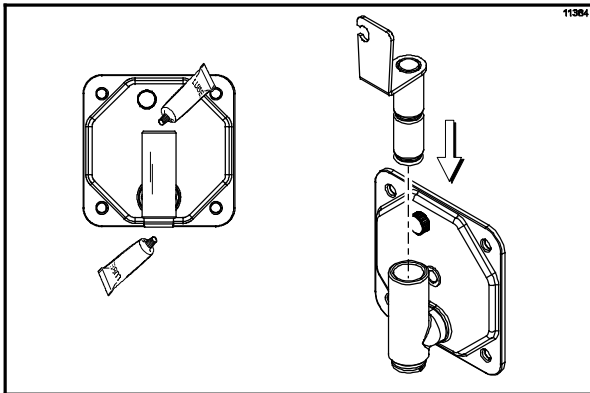

Figure 14

**Step 9**

Place the o-ring on the prime plug and lubricate.

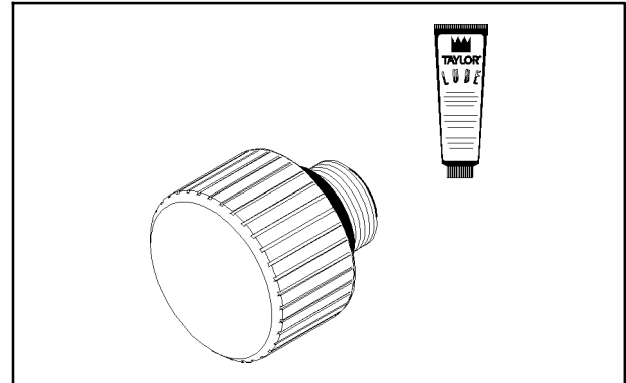

Figure 15

**Step 10**

Screw the prime plug into position on the front of the door.

**Step 11**

Place the large rubber gasket into the groove on the back side of the freezer door. Slide the white plastic front bearing onto the bearing hub. Make certain that the flanged end of the bearing is resting against the freezer door. **DO NOT lubricate** the gasket or the front bearing.

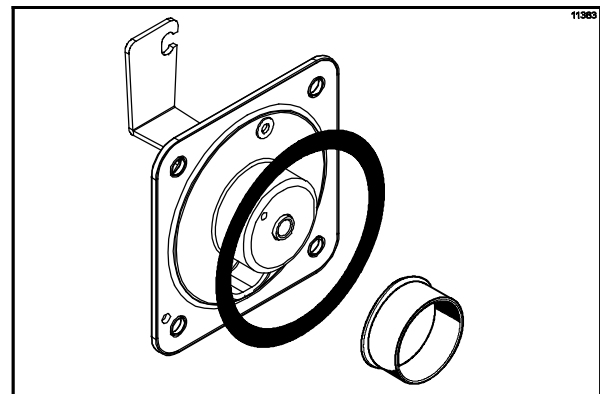

Figure 16

**Step 12**

Install the freezer door. Locate the torque rotor in the center hole of the freezer door. Position the door on the four studs on the front of the freezing cylinder and firmly push it into place. Install the four handscrews on the studs and finger-tighten equally in a criss-cross pattern to insure the door is snug. **Do not over-tighten.**

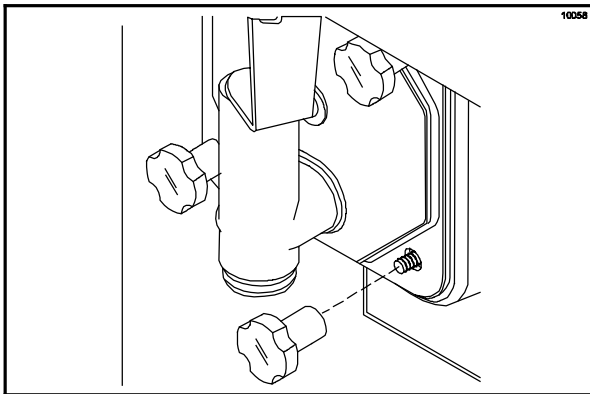

Figure 17

**Step 13**

Rotate the draw valve bracket to the left to engage the draw arm.

**Step 14**

Install the drip pan into the hole in the front panel.

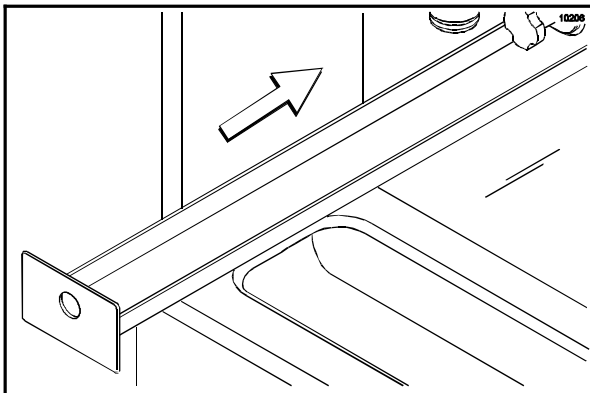

Figure 18

**Step 15**

Install the torque arm. Position the torque arm by slipping it up through the slot in the operating arm and then down into the hole in the torque rotor shaft. Check the torque arm by moving it back and forth to be sure it moves freely and easily.

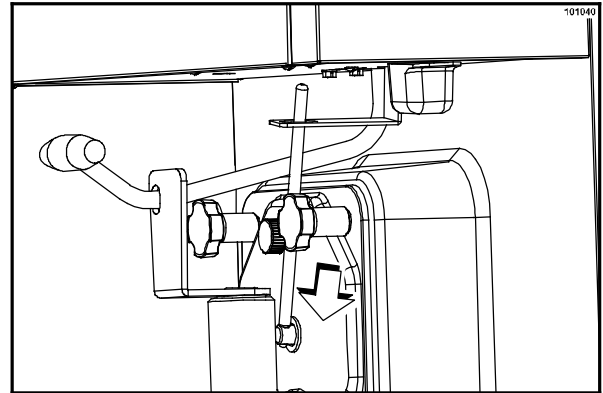

Figure 19

**Step 16**

Install the front drip tray and splash shield.

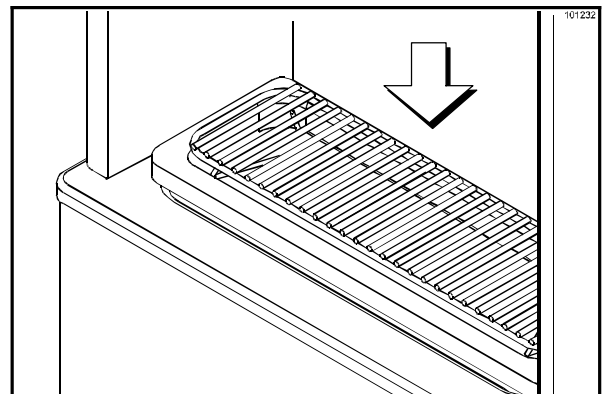

Figure 20

### Step 17

Lay the agitator in the bottom of the mix hopper for sanitizing.

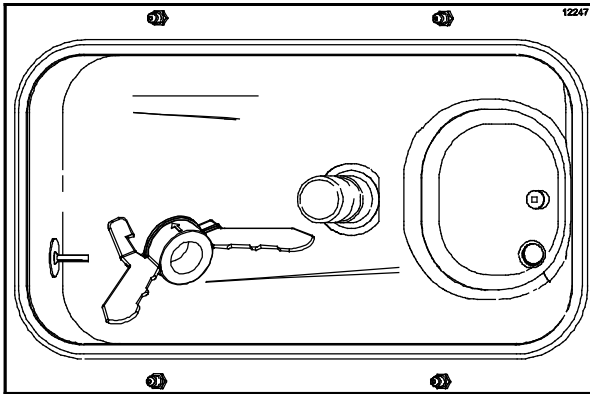

Figure 21

## Sanitizing

### Step 1

Prepare a pail of an approved 100 PPM sanitizing solution (examples: 2-1/2 gal. [9.5 liters] of Kay-5® or 2 gal. [7.6 liters] of Stera-Sheen®). USE WARM WATER AND FOLLOW THE MANUFACTURER'S SPECIFICATIONS.

### Step 2

Pour the sanitizing solution over the agitator in the bottom of the mix hopper and allow it to flow into the freezing cylinder.



**MAKE SURE YOUR HANDS ARE CLEAN AND SANITIZED BEFORE PERFORMING THESE NEXT STEPS.**

### Step 3

While the solution is flowing into the freezing cylinder, take particular care to brush clean the mix level sensing probes, the mix hopper, mix inlet hole, the outside of the agitator housing, and the agitator. Brush the exposed sides of the hopper.

### Step 4

Place the power switch in the ON position.

### Step 5

Press the WASH key and allow the sanitizing solution in the freezing cylinder to agitate for five minutes.

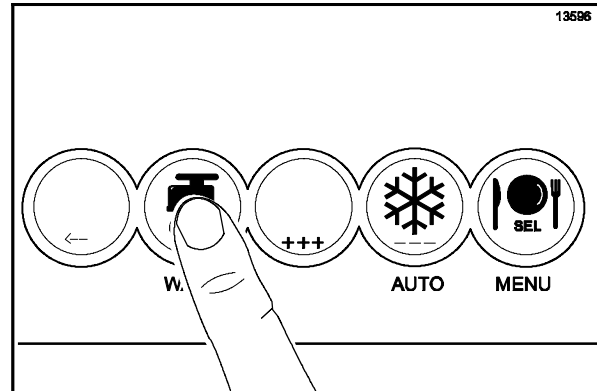

Figure 22

### Step 6

With a pail beneath the dispensing spout, open and close the draw valve six times. Draw off the remaining sanitizing solution.

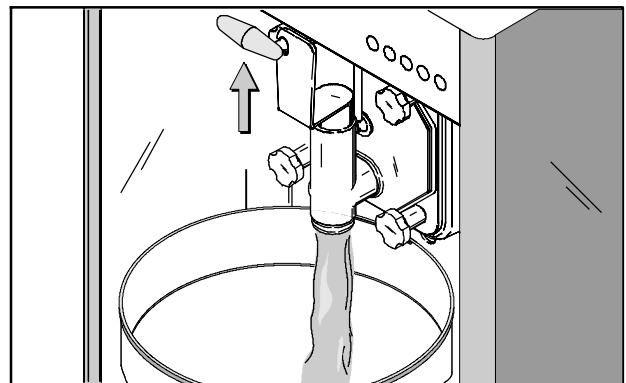

Figure 23

### Step 7

Once the sanitizer stops flowing from the dispensing spout, close the draw valve and press the WASH key, cancelling the beater motor operation.

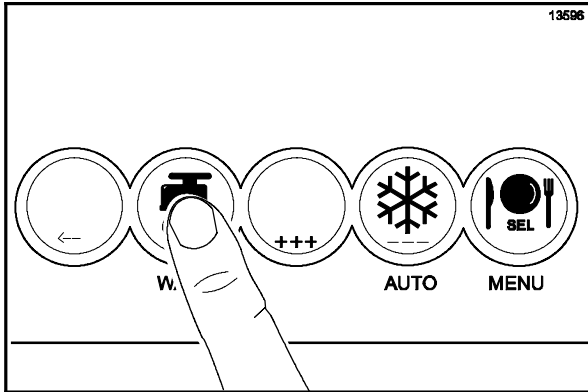

Figure 24



**MAKE SURE YOUR HANDS ARE CLEAN AND SANITIZED BEFORE PERFORMING THE NEXT STEP.**

### Step 8

Place the agitator on the agitator housing.

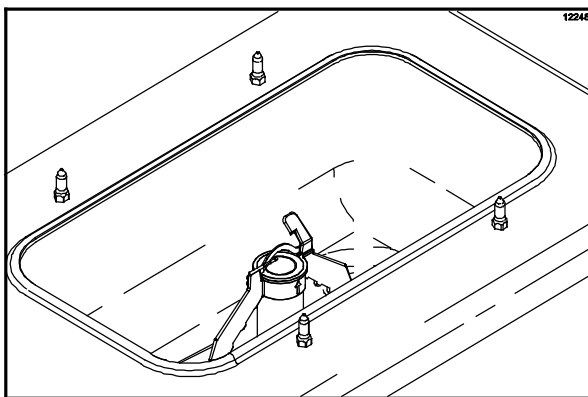

Figure 25

**Note:** If the agitator stops turning during normal operation, place the unit in the OFF mode. Remove the agitator from the agitator housing and brush clean these parts with sanitizing solution. Install the agitator back onto the agitator housing and place the unit in the ON mode. **Be sure your hands are sanitized when performing this step.**

## Priming

**Note:** If a powdered or concentrated mix will be used, follow the manufacturer's mix preparation instructions before placing the mix in the mix hopper. **DO NOT attempt to mix the product in the hopper!**

### Step 1

Place a mix pail beneath the door spout and open the draw valve. Fill the hopper with FRESH mix and allow it to flow into the freezing cylinder. This will force out any remaining sanitizing solution. When full strength product is flowing from the door spout, close the draw valve. Open the prime plug by turning it counterclockwise until the air in the freezing cylinder is allowed to escape.

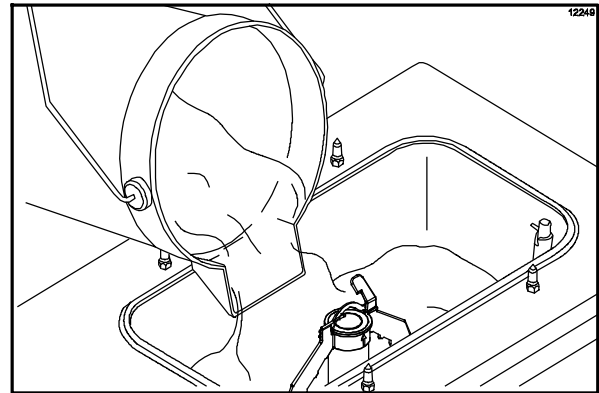

Figure 26

### Step 2

When product rises to the bleed port, close the prime plug by turning it clockwise until it is snug against the freezer door.

### Step 3

Press the AUTO key. When the unit cycles off, the product will be ready to serve.

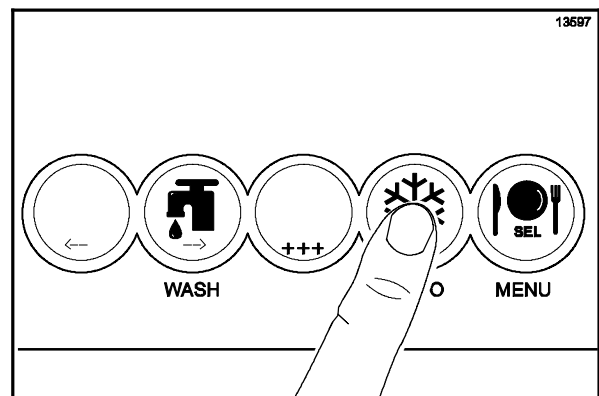

Figure 27

#### Step 4

Fill the hopper with **fresh** mix and place the mix hopper cover in position.

**Note:** Use only **FRESH** mix when priming the freezer.

## Daily Closing Procedures

**THIS PROCEDURE MUST BE PERFORMED ONCE DAILY!**

The function of the Heat Treatment Cycle is to destroy bacteria by raising the temperature of the mix in the freezing cylinder and the hopper to a specified temperature for a specified period of time, and then bringing the temperature back down low enough to retard spoilage.

The Heat Treatment Cycle will start at the time designated in the Auto Heat Time.

**Important:** The level of mix in the mix hopper must be at the line on the agitator paddle. (The mix low light must not be ON.)

**Note:** If the CLEAN MANUALLY light is flashing, the machine must be disassembled and brush cleaned within 24 hours.

The freezer must first be in the STANDBY or AUTO mode before the HEAT cycle may be started.



**MAKE SURE YOUR HANDS ARE CLEAN AND SANITIZED BEFORE PERFORMING THE NEXT STEP.**

#### Step 1

Remove the hopper cover and the agitator. Take these parts to the sink for further cleaning and sanitizing.

**Note:** Pressing the <- - arrow key will stop the agitator rotation for ten seconds.

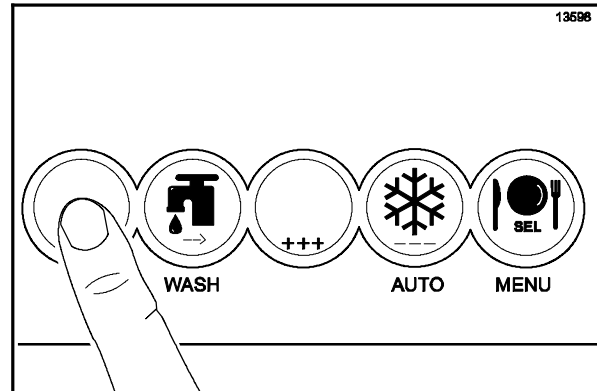

Figure 28

#### Step 2

Remove the drip pan, front drip tray, and splash shield, and take them to the sink for further cleaning.

Rinse these parts in cool, clean water. Prepare a small amount of an approved cleaning solution and brush clean the parts.

#### Step 3

Place the front drip tray and splash shield on a clean, dry, surface to air-dry overnight or until the heating cycle is complete.

#### Step 4

Prepare a small amount of an approved 100 PPM sanitizing solution. Sanitize the agitator, hopper cover, and drip pan.



**MAKE SURE YOUR HANDS ARE CLEAN AND SANITIZED BEFORE PERFORMING THE NEXT STEP.**

#### Step 5

Install the agitator back onto the agitator housing.

**Note:** Pressing the <- - arrow key will stop the agitator motion for 10 seconds.

#### Step 6

Install the hopper cover and the drip pan.



### Step 7

Return to the freezer with a small amount of cleaning solution. Dip the end brush into the cleaning solution and brush clean the door spout and bottom of the draw valve.

**Note:** To assure sanitary conditions are maintained, brush each item for a total of 60 seconds, repeatedly dipping the brush in cleaning solution.

### Step 8

Rinse a single service towel in cleaning solution and wipe down the freezer door and area around the bottom of the freezer door.

### Step 9

Rotate the draw valve bracket to the right to disengage it from the draw arm before entering a heat cycle.

**Note:** Once the heating cycle has started, it cannot be interrupted. The heating cycle will take a maximum of four hours to complete.



**DO NOT** draw product or attempt to disassemble the unit during the **HEAT** cycle. The product is hot.

When the heating cycle is complete, the control will return to the STANDBY mode.

There are three phases of the heat cycle; Heating, Holding and Cooling. Each phase has a time limit. If any one of the three phases fails to reach the proper temperatures within the time limit, the cycle will automatically abort and return to the STANDBY mode. The LCD will display the message "HEAT TREAT CYCLE FAILURE - FREEZER LOCKED - PRESS SEL KEY". The product may not be safe to serve. The freezer will be locked out of the AUTO mode. Discard the product and brush clean the machine.

## Daily Opening Procedures

Evaluate the condition of LED's (lights) and screen messages (Hard Lock or Soft Lock, etc.) before performing the Opening Procedures. As indicated in the illustration below, four flashing LED's indicate a "locked" condition.

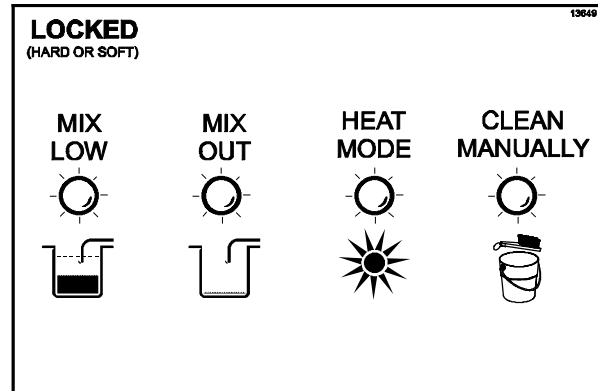

Figure 29



**MAKE SURE YOUR HANDS ARE CLEAN AND SANITIZED BEFORE PERFORMING THESE NEXT STEPS.**

### Step 1

When the heating cycle is complete, the normal display will appear, showing the machine in the STANDBY mode.

### Step 2

Rotate the draw valve bracket to the left to engage the draw arm.

### Step 3

Prepare a small amount of an approved 100 PPM sanitizing solution (examples: Kay-5® or Stera-Sheen®). USE WARM WATER AND FOLLOW THE MANUFACTURER'S SPECIFICATIONS.

### Step 4

Sanitize the front drip tray and splash shield in the sanitizing solution.



**DO NOT** use a water jet to clean or rinse the freezer. Failure to follow these instructions may result in serious electrical shock.

#### Step 5

Return to the freezer with a small amount of sanitizing solution. Dip the end brush into the sanitizing solution and brush clean the door spout and bottom of the draw valve.

**Note:** To assure sanitary conditions are maintained, brush clean each item for a total of 60 seconds, repeatedly dipping the brush in sanitizing solution.

#### Step 6

Rinse a single service towel in sanitizing solution and wipe down the freezer door and area around the bottom of the freezer door.

#### Step 7

Install the front drip tray and splash shield.

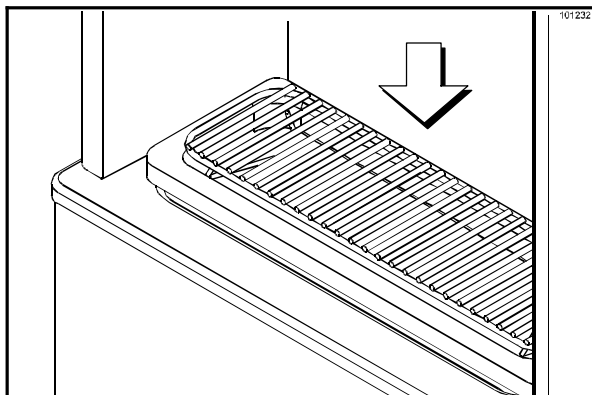

Figure 30

#### Step 8

Press the AUTO key to resume normal operation. When the unit cycles off, product is ready to serve.

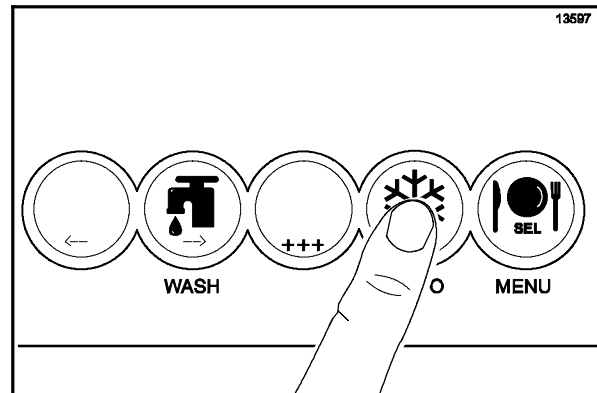

Figure 31

## Manual Brush Cleaning

**THIS PROCEDURE MUST BE PERFORMED EVERY 14 DAYS.**



**ALWAYS FOLLOW LOCAL HEALTH CODES.**

To disassemble your unit, the following items will be needed:

- Two cleaning pails
- Necessary brushes (provided with freezer)
- Cleaning solution
- Single service towels

## Draining Product From The Freezing Cylinder

### Step 1

Press the AUTO key, cancelling compressor and beater motor operation.

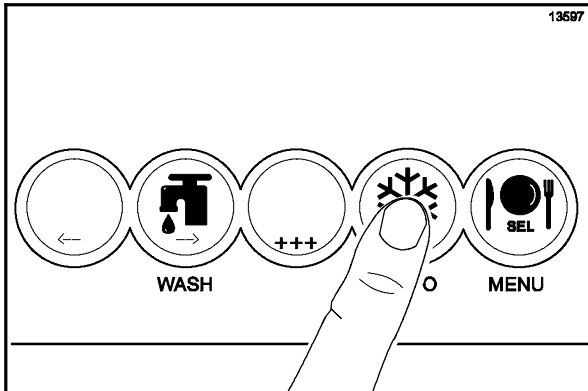

Figure 32

### Step 2

Remove the hopper cover and the agitator from the mix hopper. Take these parts to the sink for cleaning.

### Step 3

With a pail under the door spout, press the WASH key.

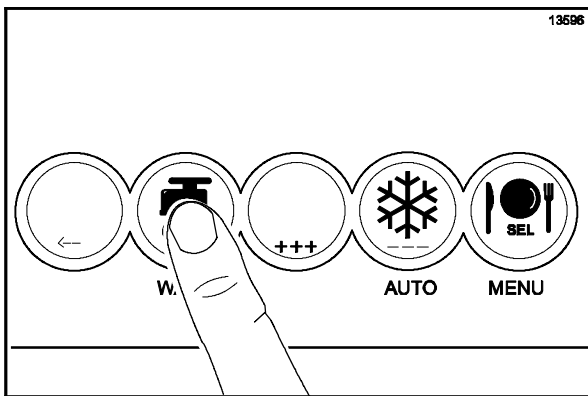

Figure 33

### Step 4

Open the draw valve and drain the remaining product from the freezing cylinder and mix hopper.

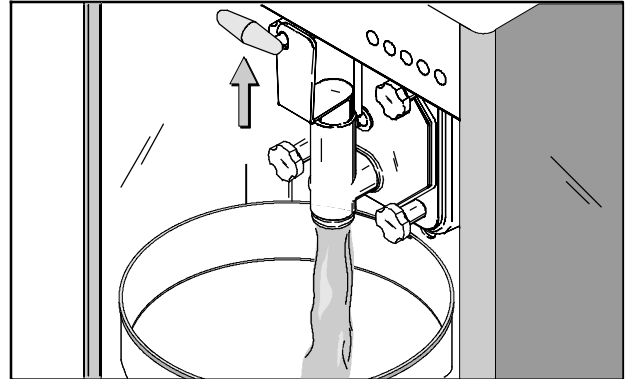

Figure 34

### Step 5

When the flow of product stops, press the WASH key, cancelling the wash cycle and close the draw valve. **Discard this product.**

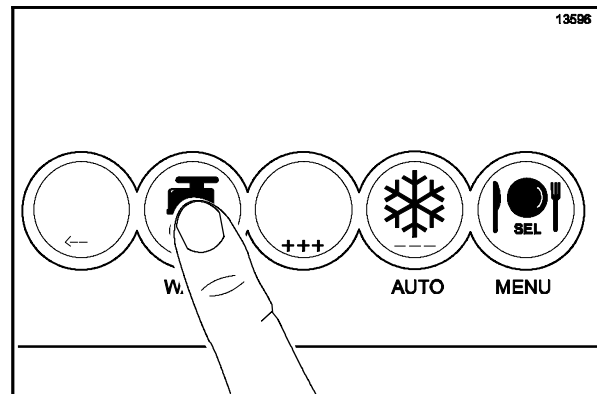

Figure 35

## Rinsing

### Step 1

Pour two gallons (7.6 liters) of **cool**, clean water into the mix hopper. With the brushes provided, scrub the mix hopper, mix level sensing probes, the outside of the agitator housing, and the mix inlet hole.

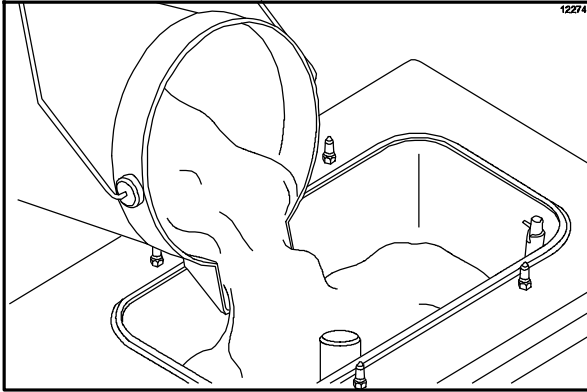

Figure 36

### Step 2

With a mix pail beneath the door spout, press the WASH key.

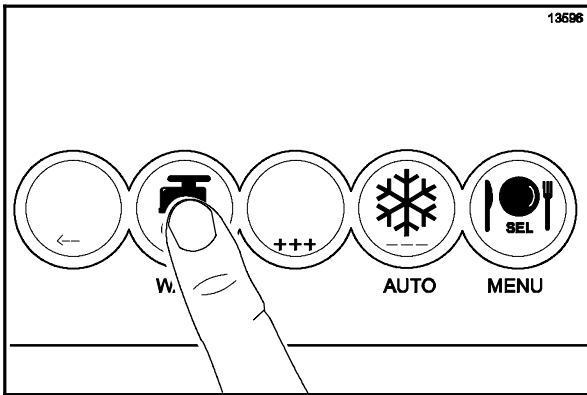

Figure 37

### Step 3

Open the draw valve on the freezer door. Drain all the rinse water from the door spout, close the draw valve, and press the WASH key cancelling the wash cycle.

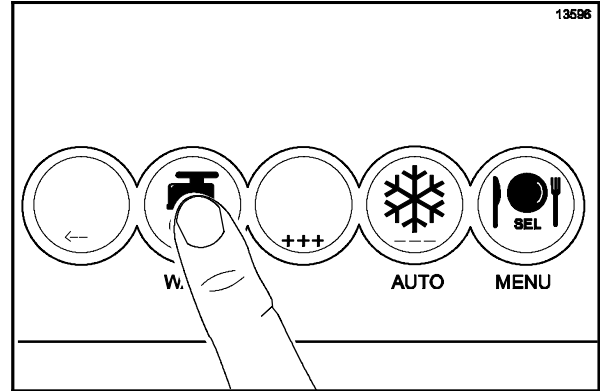

Figure 38

Repeat this procedure until the rinse water being drawn from the freezing cylinder is **clear**.

## Hopper Cleaning

### Step 1

Prepare a pail of an approved 100 PPM cleaning solution (examples: 2-1/2 gal. [9.5 liters] of Kay-5® or 2 gal. [7.6 liters] of Stera-Sheen®). **USE WARM WATER AND FOLLOW THE MANUFACTURER'S SPECIFICATIONS.**

### Step 2

Pour the cleaning solution into the hopper and allow it to flow into the freezing cylinder.

### Step 3

While the solution is flowing into the freezing cylinder, brush clean the mix hopper, mix level sensing probes, the outside of the agitator housing, and mix inlet hole.

#### Step 4

Press the WASH key and allow the cleaning solution in the freezing cylinder to agitate for five minutes.

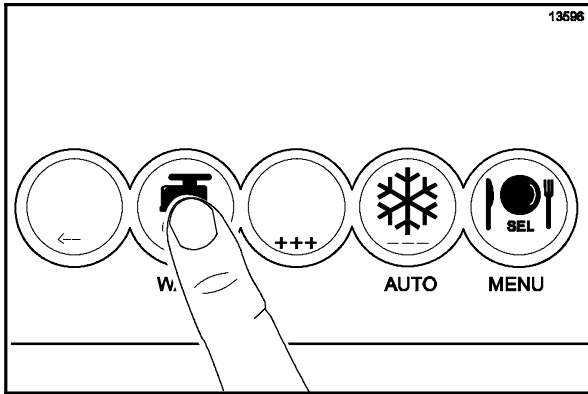

Figure 39

#### Step 5

Place an empty pail beneath the door spout.

#### Step 6

Open the draw valve on the freezer door and draw off all the solution.

#### Step 7

Once the cleaner stops flowing from the door spout, close the draw valve and press the WASH key, cancelling the wash cycle.

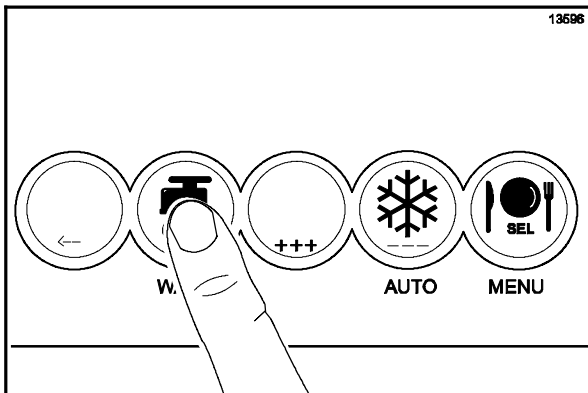

Figure 40

## Disassembly

**Note:** Failure to remove parts, brush clean and then air dry these parts, will result in damage to the related parts. These parts must be removed every 14 days or the machine will lock-out and will not operate in the AUTO mode.



**BE SURE THE POWER SWITCH IS IN THE OFF POSITION.** Failure to do so may cause injury from electrocution or hazardous moving parts.

#### Step 1

Lift out the torque arm. Rotate the draw valve bracket to the right to disengage it from the draw arm

#### Step 2

Remove the handscrews, freezer door, torque rotor assembly, beater, scraper blades, and drive shaft from the freezing cylinder. Take these parts to the sink for cleaning.

**Hint:** If the guide bearing is not connected to the end of the torque rotor shaft, it is still lodged in the beater drive shaft. To remove the guide bearing, insert the torque arm into the side hole of the drive shaft and push the bearing forward.

#### Step 3

Remove the front drip tray and splash shield.

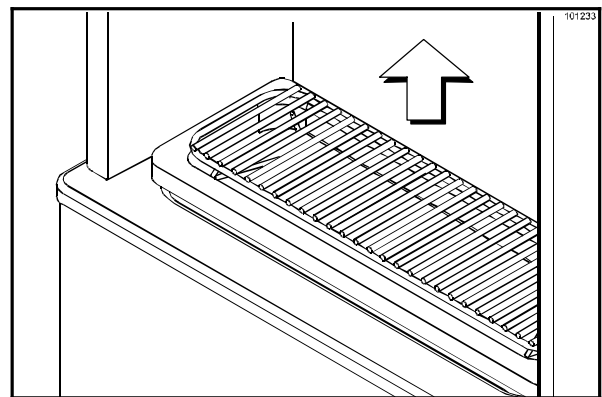

Figure 41

## Brush Cleaning



**DO NOT** use a water jet to clean or rinse the freezer. Failure to follow these instructions may result in serious electrical shock.

### Step 1

Prepare a sink with an approved cleaning solution (examples: Kay-5® or Stera-Sheen®). USE WARM WATER AND FOLLOW THE MANUFACTURER'S SPECIFICATIONS.

**IMPORTANT:** Follow label directions, as too STRONG of a solution can cause parts damage, while too MILD of a solution will not provide adequate cleaning. Make sure all brushes provided with the freezer are available for brush cleaning.

### Step 2

Remove the:

- Seal from the drive shaft
- O-rings and guide bearing from the torque rotor
- Draw valve and prime plug from the freezer door
- O-rings from the draw valve and prime plug
- Gasket and front bearing from the freezer door.

**Note:** To remove o-rings, use a single service towel to grasp the o-ring. Apply pressure in an upward direction until the o-ring pops out of its groove. With the other hand, push the top of the o-ring forward, and it will roll out of the groove and can be easily removed. If there is more than one o-ring to be removed, always remove the rear o-ring first. This will allow the o-ring to slide over the forward rings without falling into the open grooves.

### Step 3

Return to the freezer with a small amount of cleaning solution. With the black bristle brush, brush clean the rear shell bearing at the back of the freezing cylinder.

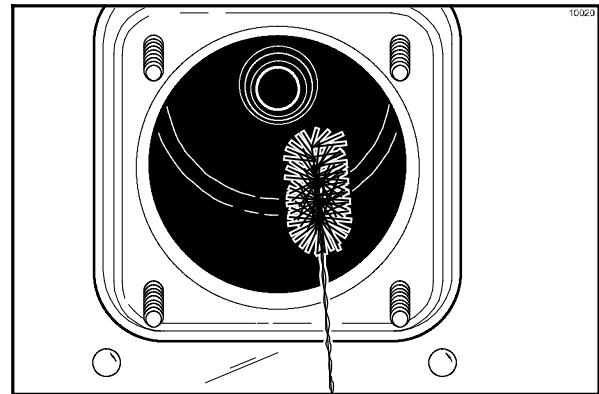

Figure 42

### Step 4

Remove the drip pan from the front panel and take to the sink for cleaning.

**Note:** If the drip pan is filled with an excessive amount of mix, refer to the Troubleshooting Guide.

### Step 5

Thoroughly brush clean all disassembled parts, including the parts tray, in the cleaning solution. Make sure all lubricant and mix film is removed. Take particular care to brush clean the draw valve core in the freezer door. Place the cleaned parts in the parts tray to air-dry overnight.

### Step 6

Wipe clean all exterior surfaces of the freezer.

# Section 7 Important: Operator Checklist

## During Cleaning and Sanitizing

Cleaning and sanitizing schedules are governed by your State or local regulatory agencies and must be followed accordingly. The following check points should be stressed during the cleaning and sanitizing operations. **CLEANING AND SANITIZING MUST BE PERFORMED EVERY 14 DAYS.**



**ALWAYS FOLLOW LOCAL HEALTH CODES.**

## Troubleshooting Bacterial Count

- 1. Thoroughly clean and sanitize the machine regularly, including complete disassembly and brush cleaning.
- 2. Use all the brushes supplied for thorough cleaning. The brushes are specially designed to reach all the mix passageways.
- 3. Use the white bristle brush to clean the mix inlet hole which extends from the mix hopper down to the rear of the freezing cylinder.
- 4. Use the black bristle brush to thoroughly clean the rear shell bearing located at the rear of the freezing cylinder. Be sure to have a generous amount of cleaning solution on the brush.
- 5. Properly prepare the cleaning and sanitizing solutions. Read and follow the label directions carefully. Too strong of a solution may damage the parts and too weak of a solution will not do an adequate job of cleaning or sanitizing.
- 6. The temperature of the mix in the mix hopper and the walk-in cooler should be below 40°F. (4.4°C.).

## Regular Maintenance Checks

- 1. Rotate the scraper blades to allow both sides of the knife edge to wear evenly. This will contribute to self-sharpening and help maintain fast, efficient freezing.
- 2. Replace scraper blades that are bent, damaged, or worn down.
- 3. Before installing beater, be certain that the scraper blades are properly attached over the beater pins.
- 4. Check the rear shell bearing for signs of wear (excessive mix leakage in drip pan) and be certain it is properly cleaned.
- 5. Using a screwdriver and cloth towel, keep the rear shell bearing and the female hex drive socket clean and free of lubricant and mix deposits.
- 6. Dispose of o-rings and seals if they are worn, torn, or fit too loosely, and replace with new ones.
- 7. Follow all lubricating procedures as outlined in "Assembly".
- 8. On air-cooled units, check the condenser for accumulation of dirt and lint. A dirty condenser will reduce the efficiency and capacity of the machine. The condenser should be cleaned **monthly** with a soft brush. **Never** use screwdrivers or other metal probes to clean between the fins.  
**Note:** For machines equipped with an air filter, it will be necessary to vacuum clean the filters on a monthly schedule.
- 9. On water cooled units, check the water lines for kinks or leaks. Kinks can occur when the machine is moved back and forth for cleaning or maintenance purposes. Deteriorated or cracked water lines should be replaced only by an authorized Taylor mechanic.

## Winter Storage

If the place of business is to be closed during the winter months, it is important to protect the freezer by following certain precautions, particularly if the building is subject to freezing conditions.

On water cooled freezers, disconnect the water supply. Relieve pressure on spring in water valve. Use air pressure on the outlet side to blow out any water remaining in the condenser. **This is extremely important.** Failure to follow this procedure may cause severe and costly damage to the refrigeration system.

Disconnect the freezer from the main power source to prevent possible electrical damage.

Your local Taylor Distributor can perform this service for you.

Wrap detachable parts of the freezer (such as the beater, blades, the drive shaft, and the freezer door) and place them in a dry, protected place. Rubber trim parts and gaskets can be protected by wrapping with moisture-proof paper. All parts should be thoroughly cleaned of dried mix or lubrication accumulations which attract mice and other vermin.



# Section 8

# Troubleshooting Guide

PROBLEM	PROBABLE CAUSE	REMEDY	PAGE REF.
<p>1. Soft lock message appears on LCD.</p>	<p>a. More than 24 hours since the last heat cycle.</p>	<p>a. The freezer must go through a heat cycle every 24 hours. The freezer must now be disassembled and brush cleaned or placed in a heat cycle.</p>	<p>17</p>
	<p>b. The power switch is in the OFF position.</p>	<p>b. The power switch must be in the ON position. The freezer must now be disassembled and brush cleaned or placed in a heat cycle.</p>	<p>17</p>
	<p>c. The freezer is not in the AUTO or STANDBY mode.</p>	<p>c. The freezer must be in the AUTO or STANDBY mode. The freezer must now be disassembled and brush cleaned or placed in a heat cycle.</p>	<p>17</p>
	<p>d. Mix out condition.</p>	<p>d. The level of mix in the mix hopper must be above the MIX OUT probe before starting the heat cycle. The freezer must now be disassembled and brush cleaned or placed in a heat cycle.</p>	<p>17</p>
	<p>e. The agitator is not installed.</p>	<p>e. The agitator must be cleaned and installed before starting the heat cycle. The freezer must now be disassembled and brush cleaned.</p>	<p>28</p>
	<p>f. The agitator is not rotating.</p>	<p>f. The agitator must be cleaned before starting the heat cycle. Disassemble the freezer and brush clean.</p>	<p>28</p>

<b>PROBLEM</b>	<b>PROBABLE CAUSE</b>	<b>REMEDY</b>	<b>PAGE REF.</b>
2. Hard lock message appears on LCD.	a. There has been a thermistor failure (freezing cylinder, hopper, or glycol) during the heat treatment process.	a. The freezer must be disassembled and brush cleaned.	16
	b. More than 14 days since last brush cleaning.	b. The freezer must be disassembled and brush cleaned every 14 days.	16
3. No product being dispensed with draw valve open and machine in the AUTO mode.	a. There is an inadequate amount of mix in the hopper.	a. Fill the hopper with mix.	27
	b. There is a freeze-up in the mix inlet hole.	b. Call a service technician to adjust hopper temperature.	---
	c. Beater rotating counter-clockwise.	c. Contact service technician to correct rotation to clockwise.	---
4. The product is too stiff.	a. Improper lubrication of torque rotor o-rings.	a. Lubricate the o-rings properly.	23
	b. Improper consistency control adjustment.	b. Product should be dispensed at 27° to 29°F. (-2.8° to -1.7°C.).	13
	c. The torque rotor is binding.	c. Before installing the torque arm, check to see if the torque rotor can be rotated freely without binding.	25
	d. Torque arm not installed.	d. Install torque arm.	25

PROBLEM	PROBABLE CAUSE	REMEDY	PAGE REF.
5. The product is too soft.	a. Improper consistency control adjustment.	a. Product should be dispensed at 27° to 29°F. (-2.8° to -1.7°C.).	13
	b. The torque rotor is binding.	b. Before installing the torque arm, check to see if the torque rotor can be rotated freely without binding.	23
	c. Improper lubrication of torque rotor o-rings.	c. Lubricate the o-rings properly.	24
	d. Lubrication of torque rotor guide bearing.	d. <b>Do not</b> lubricate the guide bearing.	23
	e. Not enough air space around unit (air-cooled).	e. Allow for adequate air flow across the condenser.	2
	f. Dirty condenser (air-cooled)	f. Clean regularly.	35
	g. The mix is out-of-date.	g. Use only fresh mix.	28
	h. Loss of condenser cooling.	h. Locate cause of water loss and correct.	---
6. The mix in the hopper is too cold.	a. The temperature is out of adjustment.	a. Call a service technician to adjust hopper temperature.	---
7. The mix in the hopper is too warm while in the AUTO mode.	a. The hopper cover is not in position.	a. Place the cover in position.	28
	b. The temperature is out of adjustment.	b. Call a service technician to adjust hopper temperature.	---
8. The drive shaft is stuck in the gear box coupling.	a. Mix and lubricant collected in the drive coupling.	a. Brush-clean rear shell bearing area regularly.	35
	b. Rounded corners of drive shaft, coupling, or both.	b. Call service technician to correct cause and replace the necessary components. (Note: Do not lubricate end of drive shaft.)	22

<b>PROBLEM</b>	<b>PROBABLE CAUSE</b>	<b>REMEDY</b>	<b>PAGE REF.</b>
9. The freezing cylinder walls are scored.	a. The front bearing is missing or worn.	a. Install or replace front bearing.	24
	b. The gear box is out of alignment.	b. Call a service technician to realign gear box.	---
	c. The beater pins are broken.	c. Call service technician to repair or replace.	35
	d. The beater assembly is bent.	d. Call a service technician to repair or replace beater and to correct cause of insufficient mix in freezing cylinder.	---
10. Excessive mix leakage from the dispensing spout.	a. The draw valve o-rings are worn or missing.	a. Replace regularly.	42
	b. There is unadequate lubrication on the draw valve o-rings.	b. Lubricate properly.	24
	c. The wrong type of lubricant was being used (Example: petroleum base lubricant).	c. Use food grade lubricant (Example: Taylor Lube High Performance).	22
11. Excessive mix leakage into the rear drip pan.	a. Worn or missing seal on drive shaft.	a. Replace regularly.	35
	b. Inadequate lubrication of drive shaft.	b. Follow lubrication procedures in "Assembly".	22
	c. Seal installed inside-out on drive shaft.	c. Install correctly.	22
	d. Bad rear shell bearing.	d. Call service technician to replace rear shell bearing.	---
	e. Drive shaft and beater working forward.	e. Call service technician.	---

<b>PROBLEM</b>	<b>PROBABLE CAUSE</b>	<b>REMEDY</b>	<b>PAGE REF.</b>
12. No freezer operation after placing unit in the AUTO mode.	a. Unit unplugged.	a. Plug into wall receptacle.	---
	b. Circuit breaker off or blown fuse.	b. Turn circuit breaker on or replace fuse.	---
	c. Beater motor out on reset.	c. Clear the tone and reset freezer.	13
	d. Compressor off on high pressure cut out.	d. Clear the tone. Place unit in the AUTO mode. If problem persists, contact service technician.	18
	e. Water turned off (water-cooled units.)	e. Re-establish water supply.	---
13. Liquid Crystal Display is blank after power switch is placed in the ON position.	a. Unit unplugged.	a. Plug into wall receptacle.	---
	b. Circuit breaker off or blown fuse.	b. Turn circuit breaker on or replace fuse.	---
	c. Screen intensity out of adjustment.	c. Call service technician to adjust.	---
14. Product not feeding into freezing cylinder.	a. Inadequate mix in hopper.	a. Fill hopper with mix.	27
	b. Mix inlet hole frozen up.	b. Hopper temperature needs adjustment. Call service technician.	---

## Section 9

# Parts Replacement Schedule

PART DESCRIPTION	EVERY 3 MONTHS	EVERY 6 MONTHS	ANNUALLY	QTY.
Drive Shaft Seal	X			1
Front Bearing	X			1
Freezer Door Gasket	X			1
Draw Valve O-Rings	X			2
Torque Rotor Guide Bearing	X			1
Torque Rotor O-Rings	X			2
Prime Plug O-Ring	X			1
Double Ended Brush		Inspect & Replace if Necessary	Minimum	1
Black Bristle Brush, 1" x 2"		Inspect & Replace if Necessary	Minimum	1
White Bristle Brush, 1-1/2" x 2"		Inspect & Replace if Necessary	Minimum	1
White Bristle Brush, 3" x 7"		Inspect & Replace if Necessary	Minimum	1
End Brush-Door Spout		Inspect & Replace if Necessary	Minimum	1

# Section 10

# Parts List

DESCRIPTION	PART NUMBER	H62 QTY.	H63 QTY.	WARR. CLASS	REMARKS	PARTS UPDATE
ACCUMULATOR-COPPER 2"DIA 13"	053377	1	1	103		
ADAPTOR A.-CASTER	X18915		4	103		
ADAPTOR-5/16 BARB-5/16FS	047958	7	4	103		
ARMAFLEX 1/2 ID X 3/8WALL	R50325	10'	10'	000		
ARMAFLEX 3/8 ID X 1/4WALL	R50322	1'	5'	000		
ARM-TORQUE 5.813L SS	067428	1	1	103		
BEARING-FRONT	013116	1	1	000		
BEARING-GUIDE	014496	1	1	000		
BEATER A.-7QT-BLADELESS	X45719	1	1		S/N M2017162 & UP	U/D #223
BEATER A.-7QT-1 PIN-SUPPO	X46233			103	S/N M2017161 & PRIOR	U/D #223
+BLADE-SCRAPER-PLASTIC 9-1	046237			000	S/N M2017161 & PRIOR	U/D #223
+CLIP-SCRAPER BLADE 8.75 I	046238			103	S/N M2017161 & PRIOR	U/D #223
BELT-V-4L420	004338	1		000		
BELT-V-4L370	004227		1	000		
BLADE A.-AGITATOR *C708*	X56591-SP1	1	1		S/N M2017162 & UP	U/D #223
BLADE A.-AGITATOR *C708*	X56591			103	S/N M2017161 & PRIOR	U/D #223
BLADE-SCRAPER-PLASTIC 9-1	046237			000	S/N M2017161 & PRIOR	U/D #223
BLOCK-TERMINAL 2P L1,L2 - 1PH	039422	1	1	103	208-230V 60HZ 1PH	
BLOCK-TERMINAL 3P L1,L2,L3 - 3PH	039423	1	1	103	208-230V 60HZ 3PH - 3 WIRE	
BLOCK-TERMINAL 3P .25 SPA	057201	1	1	103		
BLOCK-TERMINAL-PLUG 8P .2 SIP	040322-004	1	1	103		
BLOCK-TERMINAL-PLUG 10P .2 SIP	040322-005	1	1			
BOLT-CARRIAGE 1/4-20X3/4	012347	4	4	000		
BRUSH-DBL END-PUMP & FEED	013072	1	1	000		
BRUSH-DRAW VALVE 1-1/2"OD	014753	1	1	000		
BRUSH-END-DOOR-SPOUT-SS-H	039719	1	1	000		
BRUSH-MIX PUMP BODY-3" X	023316	1	1	000		
BRUSH-REAR BRG 1"D X 2"LG	013071	1	1	000		
BUSHING-PANEL	013289		6	103		
CABLE-RIBBON-14C-14"L SIP	040040-015	1	1	103		
CABLE-RIBBON-10C-34"L-DIL	040040-023	1	1	103		
CABLE-RIBBON-20C-35"L-DIL	040040-026	1	1	103		

+ Available Separately

DESCRIPTION	PART NUMBER	H62 QTY.	H63 QTY.	WARR. CLASS	REMARKS	PARTS UPDATE
CABLE-RIBBON-20C-33"L-DIL	040040-027	1	1	103		
CABLE-RIBBON-50C-35"L-DIL	040040-044	1		103		
CABLE-RIBBON-50C-20"L-DIL	040040-011		1	103		
CAP-AGITATOR HOUSING	080071	1	1		S/N M2017162 & UP	U/D #223
CAPACITOR-MOTOR-AGITATOR	057525	1	1	103		
CAPACITOR-RUN 20UF/440V	012906	1	1			
CAPACITOR-RUN 4.0UF/400V	500311	1				
CAPACITOR-RUN 4UF/440V	051785		1	103		
CARD-CHECKOUT-HT-5YR	041247-W5	1	1	000		
CASTER-4" SWV 5/8 STEM X	018794		2	103		
CASTER-4" SWV 5/8 STEM W/BRAKE	034081		2	103		
CLAMP-HOSE 35/64-STEPLESS	047344	16	14	000		
CLIP-SCRAPER BLADE 8.75 I	046238			103	S/N M2017161 & PRIOR	
CLIP-RETAINING THERMISTOR	066099	1	1			
COLLAR-HOLDING-STEPPED *0H63*	067952	3	3			
+SCREW-10-32X3/4 SLTD OVAL	001086	3	3	000		
COLLAR-HOLDING .730DX.109	019481		2	103		
+SCREW-10-32X3/4 SLTD OVAL	001086		2	000		
+WASHER-#10 INTERNAL TOOTH	024420		2	000		
COMPRESSOR RS80C1E-CAV-22	051958-27	1	1	512	208-230V 60HZ 1PH	
+CAPACITOR-RUN 20UF/440V	012906	1	1	103		
+CAPACITOR-START 189-227UF/33	033044-1	1	1	103		
+ RELAY-START-COMPRESSOR	051957-27	1	1	103		
COMPRESSOR RS80C1E-TF5-224	051958-33	1	1	512	208-230V 60HZ 3PH - 3 WIRE	
CONDENSER-AC 16X16 3ROW 14FPI	056944	1		103		
CONDENSER-AC 12LX18HX4.3-	019558		1	103		
COUPLING-DRIVE 3/4 HEX X	012721	1		103		
DECAL-DEC-TAYLOR	052284-SP	1	1	000		
DECAL-INST-CLN-DAY-HT-SHK	046698	1	1	000		
DECAL-INST-CLN-MAN-HT	046699	1	1	000		
DECAL-TROUBLESHOOT	038374	1	1	000		
DIAGRAM-WIRING *H62*	067368-27	1	1	000	208-230V 60HZ 1PH	
DIAGRAM-WIRING *H62*	067368-33	1	1	000	208-230V 60HZ 3PH - 3 WIRE	

+ Available Separately



DESCRIPTION	PART NUMBER	H62 QTY.	H63 QTY.	WARR. CLASS	REMARKS	PARTS UPDATE
DISPLAY-LIQUID CRYSTAL	X38062-SER	1	1	103		
DOOR A.-PARTIAL-1 SPT	X67194-SER	1	1	103		
+PLUG-PRIME *H63*	067192	1	1	103		
+O-RING-5/8 OD X .103W	016030	1	1	000		
+VALVE A.-DRAW *H63*	X56119	1	1	103		
+O-RING-1-1/16 OD X.139W	020571	2	2	000		
+GASKET-DOOR 5.177ID X 5.9	016672	1	1	000		
DRYER-FILTER-HP62-3/8 X 1	048901	1	1	000		
EYELET-RESET BUTTON	013739	1	1	103		
FAN-5 BLADE 12" PUSH 26DE	029771		1	103		
FASTENER-CLIP 1/4-20 U-TY	045865	12	16	000		
FASTENER-DOOR LATCH	030787	2		000		
FASTENER-DOOR STRIKE	030788	2		000		
FILTER A.-GLYCOL	X47323-SP	1		000		
FILTER-INLINE-GLYCOL-40 MICRON	041670	1				
FILTER A.-GLYCOL	X47323		1			
FILTER-INLINE-GLYCOL-40 MICRON	041670		1			
FILTER-AIR-21.688X15.813H	052779-9	1		000		
FILTER-AIR-18.00LX14.25HX.70W	052779-4		1	000		
FILTER-CORCOM 6EH1	040140-001	1	1	000		
GASKET-BASE PAN *0H62*C92	067316	1		000		
GASKET-DOOR 5.177ID X 5.9	016672	1	1	000		
GASKET-DRIP LIP	036435	1	1	000		
GEAR A.*REDUCER 4.21:1	021286-SER	1		212		
GEAR A.-REDUCER 4.21:1	012235-SER		1	212		
GUARD-POWER SWITCH	034830	1		103		
GUIDE A.-DRIP PAN	X28863	1		103		
GUIDE A.-DRIP PAN *H60*	X47900		1	103		
HARNES A.-WIRE-GLYCOL PU	X58481	1	1	103		
HARNES-WIRE-CONTROL *0H62*	067398	1	1			
HARNES-WIRE-THERM.PROBES H62	059241	1	1			
HARNES-WIRE-MAIN POWER *0H62	067405-27G	1			208-230V 60HZ 1PH	
HARNES-WIRE-MAIN POWER *0H63*	067364-27G		1		208-230V 60HZ 1PH	

+ Available Separately

DESCRIPTION	PART NUMBER	H62 QTY.	H63 QTY.	WARR. CLASS	REMARKS	PARTS UPDATE
HARNESS-WIRE-MAIN POWER	067405-33G	1			208-230V 60HZ 3PH - 3 WIRE	
HARNESS-WIRE 5472 MAIN POWER	056884-33G		1		208-230V 60HZ 3PH - 3 WIRE	
HARNESS-WIRE-BTR MTR *H63*	067363-27G	1				
HARNESS-WIRE-BTR MTR *H63*	067363-27G		1			
HARNESS-WIRE-COMP *0H62-0	067365-33	1	1		208-230V 60HZ 3PH - 3 WIRE	
HARNESS-WIRE-CTRL/TORQUE H60	059244	1	1			
HARNESS-WIRE-FAN *0H62*	067391-G	1				
HARNESS-WIRE 5472 COND FAN MTR	056893		1			
HEATER A.-GLYCOL-2500W *H60*	X47331-27	1		103		
THERMOSTAT-HI LIMIT OPEN 200	035786	1		103		
HEATER-COMPRESSOR CRANKCASE	067429-27	1	1	103	H62-33 3/12/2009 - H63-33 3/25/2009	
HOSE-RUBBER 5/16"ID X 9/16"OD	R502011	15'	15'	000		
HOUSING A.-AGITATOR	X80290-03	1	1	103	S/N M2017162 & UP	U/D #223
CAP-AGITATOR HOUSING	080071	1	1	103	S/N M2017162 & UP	U/D #223
BODY-AGITATOR HOUSING *C708*	056588	1	1	103		
BUSHING-AGITATOR MAGNET *C70	057342	1	1	000		
CAPACITOR-MOTOR-AGITATOR	057525	1	1	103		
MAGNET A.-AGITATOR-INNER	066937	1	1	103		
MOTOR-AGITATOR-24VAC 50/60 H	050535-03	1	1	103		
O-RING-1-3/8 OD X .070W	017395	1	1	000		
PLATE-HOLDING-AGITATOR *C708	056587	1	1	103		
SCREW-4-40X1/4 SOCKET HEAD	600165	4	1	000		
SCREW-8-32X3/16 SOCKET SET	006812	2	1	000		
HOUSING A.-AGITATOR *C708	X56586-03J			103	M1035560-M2017161 & UP REPLACED X56586-03	
INTERLOCK A.-DOOR	X65658			103		
SWITCH-REED*DOOR INTERLOCK*68"	056771			103		
SPRING-INTERLOCK DOOR	065409			000		
FITTING DOOR INTERLOCK	065471			103		
KIT A.-COVER-HOPPER*SINGL	X65368	1		103		
LABEL-CAUTION-AGITATOR	045191	1		000		
KIT A.-COVER-HOPPER*SINGL	X65369		1	103		
LABEL-CAUTION-AGITATOR	045191		1	000		

+ Available Separately

DESCRIPTION	PART NUMBER	H62 QTY.	H63 QTY.	WARR. CLASS	REMARKS	PARTS UPDATE
KIT A.-TUNE UP*0H63*	X67224	1	1	000		
BEARING-FRONT	013116	1	1	000		
BEARING-GUIDE	014496	1	1	000		
GASKET-DOOR 5.177ID X 5.938O	016672	1	1	000		
O-RING-.291 ID X .080W	018550	2	2	000		
O-RING-1-1/16 OD X.139W	020571	2	2	000		
O-RING-5/8 OD X .103W	016030	1				
SEAL-DRIVE SHAFT	032560	1	1	000		
TOOL-O-RING REMOVAL-FREEZER	048260-WHT	1	1	000		
KIT-MOUNTING-COMPRESSOR R	052196	1	1	000		
KNOB-ADJUSTMENT	014499	1	1	103		
+SCREW-ADJUSTMENT	014498	1	1	000		
KNOB-DRAW VALVE	013635	1	1			
+NUT-LOCK KNOB	013649	1	1			
LABEL-CAUTION-AGITATOR	045191	1	1			
LABEL-CAUTION-GRD-PERM-ENG/S	032164	1	1			
LABEL-DOOR-MOVE PART	032749	1	1	000		
LABEL-OVERLOAD SETTING	045384	1	1			
LABEL-WARN-CONDENSER-SHARP	059287	1	1			
LABEL-WARN-COVER	051433	1	1			
LABEL-WARN-ELEC-SGL-SMALL	032717	1	1			
LUBRICANT-TAYLOR HI PERF-	048232	1	1	000		
MAN-OPER H62/H63 YUM	067343-M	1	1	000		
MOTOR A.-FAN 185 WATT 1400RP	500302-27	1		103		
+CAPACITOR-RUN 4.0UF/400V	500311	1		103		
MOTOR-FAN 80 WATT 1550 RPM C	051744-27		1	103		
+CAPACITOR-RUN 4UF/440V	051785		1	103		
MOTOR-AGITATOR-24VAC 50/60 HZ	050535-03	1	1	103		
+CAPACITOR-MOTOR-AGITATOR	057525	1	1	103		
MOTOR-1/2 HP	059742-27	1	1	212		
CAPACITOR-START 72-88UF/330V	059757	1	1	103		U/D 208
CAPACITOR-RUN 10UF/370V	059998	1	1	103		U/D 208
NUT-STUD *GENERAL USAGE*	021508	4	4	103		

+ Available Separately

DESCRIPTION	PART NUMBER	H62 QTY.	H63 QTY.	WARR. CLASS	REMARKS	PARTS UPDATE
O-RING-291 ID X .080W	018550	2	2	000		
PAIL-MIX 10 QT.	013163	1	1	000		
PAN-DRIP 11-5/8 LONG	027503	1		103		
PAN-DRIP 19-1/2 LONG	035034		1	103		
PANEL A.-DUCT-RIGHT *0H62*	X67499-SP1	1				
PANEL A.-FRONT-LOWER *0H62*	X69419	1			S/N M1054820 & UP	
PANEL-FRONT-UPPER *0H62*	067305	1				
PANEL-SIDE-LEFT *0H62*	067500-SP1	1				
PANEL-REAR *0H62*	067501	1				
PANEL A.-FRONT *H63*	X48371		1	103		
PANEL A.-DUCT-AIR *0H63*	X67958-SP1		1	103		
PANEL-SIDE *H60*LEFT	067721-SP1		1	103		
PANEL-REAR W/LOUVERS *547	026980-SP		1	103		
PANEL-SERVICE *H63*	048380		1	103		
PCB A.-CONTROL *H62* BLADELESS	X80551-SER	1	1			40932
CHIP-SOFTWARE *H62* BLADELESS	X40636-SER	1	1		S/N M2017162 & UP	
CONTROL-ROHS-UVC2	X63927-SER	1	1			
PCB A.-CONTROL *H60* UVC2 ROHS	X65158-SER			212	M2017161 & PRIOR 3/02/09 - 4/13/09	
CHIP-SOFTWARE *H60* CTRL UVC2	X40783			103	S/N M2017161 & PRIOR	
CONTROL-ROHS-UVC2	X63927-SER			212	S/N M2017161 & PRIOR	
PCB A.-INTERFACE-ROHS-HT INTF BASE-UK	X63920-SER	1	1	212		
CHIP-SOFTWARE MIX LEVEL	X40799-SER	1	1	103		
PCB A.-LED-4 POSITION	X63930-SER	1	1	212	DEC PLATE	
PIN-RETAINING-HOPPER COVE	043934	4	4	103		
PLATE A.-DEC-H63*PARTIAL	X48382-SP	1	1	103		
PROBE A.-MIX LOW-HT	X42077	1	1	103		
+DISC-PROBE *SQ HOLE*	030965	1	1	103		
+SPACER-PROBE *SQ HOLE*	030966	1	1	103		
PROBE A.-MIX OUT-SQUARE HOLE	X41348	1		103		
SPACER-PROBE-SQUARE HOLE-7/8	041346	1		103		
SPACER-PROBE-ROUND HOLE-5/8D	041347	1		103		
SPACER-PROBE-MIX LOW *8634*	043908	1		103		
PULLEY-AK20X5/8	041162	1	1	103		

+ Available Separately

DESCRIPTION	PART NUMBER	H62 QTY.	H63 QTY.	WARR. CLASS	REMARKS	PARTS UPDATE
PULLEY-AK74 X 5/8	051013	1	1	103		
PUMP-GLYCOL-1/8NPT-1650 RPM	041785	1	1	212		
+ADAPTOR-1/8MP X 5/16 BARB-BR	047325	2	2	103		
+BOOT-PUMP-GLYCOL	042131	1	1	000		
+CLAMP-HOSE 35/64-STEPLESS EA	047344	2	2	000		
+ELBOW-1/8P-STREET-BRASS	021760	2	2	103		
+HOSE-RUBBER 5/16"ID X 9/16"OD	R502011	4'	4'	000		
RELAY-3 POLE-20A-208/240 50/60	066795-33	1	1	103		
RELAY-DPDT 100UA TO 7A 1/8HP	052111-03	1	1	103		
RELAY-SPST-30 A-240 V	032607-27	1	1	103		
RELAY-START-COMPRESSOR	051957-27	1	1	103		
RING A.-AIR FLOW-COND.*	X57006	1		103		
SANITIZER-STERA SHEEN -GREEN	055492	1	1	000		
SHAFT-BEATER *0H62*	067489	1			0H62 - 6/1/2009 & UP	
+SEAL-DRIVE SHAFT	032560	1		000		
SHAFT-BEATER	036412	1		103	0H62 - 3/02/09 - 5/26/09	
SHAFT-BEATER	035527		1	103		
+SEAL-DRIVE SHAFT	032560		1	000		
SHELF-TRAY-DRIP	056076	1		103		
SHELL A.-INSULATED *H62*H	X67284	1		512		
+STUD-NOSE CONE 5/16-18X3/	011390	4		103		
SHELL A.-INSULATED *H63*	X67863		1	512	S/N M1035560 & UP	
+STUD-NOSE CONE 5/16-18X3/	011390		4	103		
SHIELD-MIX-GEAR REDUCER 3	013356		1	103		
SHIELD-RIBBON CABLE *5472	045059		1	103		
SHIELD-SPLASH *M706/707/7	049203	1		103		
SHIELD-SPLASH-WIRE 13-11/	046177		1	103		
SHIELD-TORQUE SWITCH *0H6	067442	1		103		
SKIRT-AIR FLOW *60*H60*H6	055801		1	103		
STANDOFF-NYLON 6-32X3/8L	040280-008	4	6	000		
STARTER-1 PHASE 2.5 TO 4 AMP	066794-27H	1	1	103		
OVERLOAD	067461-1H	1	1	103		
STUD-NOSE CONE 5/16-18X3/	011390	4	4	103		

+ Available Separately

DESCRIPTION	PART NUMBER	H62 QTY.	H63 QTY.	WARR. CLASS	REMARKS	PARTS UPDATE
SWITCH A.-DRAW *H60*	X54791	1	1	103		
ARM A.-DRAW *H60*	X54792	1	1	103		
SWITCH-LEVER-SPDT-11A-125-27	039252	1	1	103		
PIN-PIVOT	015478	1	1	103		
E-RING 3/16 .335 OD 1500-18P	049178	1	1	000		
+KNOB-DRAW VALVE	013635	1	1	103		
+NUT-LOCK KNOB	013649	1	1	000		
SWITCH A.-REED INTERLOCK DOO	X65658	1	1	103		
SWITCH-REED*DOOR INTERLOCK*6	056771	1	1	103		
SPRING-INTERLOCK DOOR	065409	1	1	000		
SWITCH A.-TORQUE *H60*	X46656-SP	1	1	103	M1035560 & UP REPLACES X46656	
HUB A.-ARM	X69208	1	1	103	M1035560 & UP REPLACES X17033	
SWITCH-LEVER-SPDT-1A-125V	062022	1	1	103		
+SPRING-TORQUE*BROWN*	067458	1	1	103	M1035560 & UP REPLACES 014497	
+KNOB-ADJUSTMENT	014499	1	1	103		
+SCREW-ADJUSTMENT	014498	1	1	000		
SWITCH-MEMBRANE-5 POSITION-8	044520	1	1	103		
SWITCH-PRESSURE 440 PSI-SOLD	048230	1	1	103	LINE A.-DISCHARGE *0H62*	
SWITCH-TOGGLE-DPDT*ON-NONE-ON	024295	1	1			
TANK-GLYCOL 1.5QT-PLASTIC	047314	1	1	103		
THERMOSTAT-HI LIMIT OPEN 200 F	035786	1	1	103	GLYCOL HEATER	
TORQUE A. *H60* SOFT SLUS	X67190	1	1	103		
+ARM-TORQUE 5.813L SS	067428	1	1	103		
TRANS.-120/208/240V PRI 24VSEC	051660	1	1	103		
TRANS.-CONT.-32VA 120/200/240V	054834	1		103		
TRANS.-CONT.-40VA 120/200	045754		1	103		
TRAY-DRIP *C706/C707*BLAC	056858	1		103		
TRAY-DRIP 14.8	046275		1	103		
TRAY-PARTS-BARREL-7 QT *0H62	067406	1	1	000		
TRIM-REAR CORNER *H60*	046668		2	103		
VALVE-ACCESS-1/4MFL X 3/8ODSDR	053565	2	2	103		
VALVE-EXP-AUTO-1/4S X1/4	046365	1	1	103		
+BOOT-VALVE-EXPANSION	050900	1	1	000		

+ Available Separately

## 50 Cycle Units

DESCRIPTION	PART NUMBER	H62 QTY.	H63 QTY.	WARR. CLASS	REMARKS
BELT-V-4L410	007530		1	000	220-240V 50HZ 1PH / 380-415V 50HZ 3N~
BELT-V-4L420	004338	1			220-240V 50HZ 1PH / 380-415V 50HZ 3N~
BELT-V-4L410	007530	1		000	200V 50/60HZ 3PH / 220-240V 50HZ 1PH / 380-415V 50HZ 3N~
BELT-V-4L370	004227		1		200V 50/60HZ 3PH
BLOCK-TERMINAL 2P L1, N	039421	1	1	103	220-240V 50HZ 1PH
BLOCK-TERMINAL 7P GREEN	024156	1	1		200V 50/60HZ 3PH / 220-240V 50HZ 1PH / 380-415V 50HZ 3N~
BLOCK-TERMINAL 3P L1,L2,L	039423	1	1		200V 50/60HZ 3PH
BLOCK-TERMINAL 4P L1, L2, L3, N	039424	1	1	103	380-415V 50HZ 3N~
BLOCK-TERMINAL 7P GREEN	024156	1	1	103	220-240V 50HZ 1PH / 380-415V 50HZ 3N~
BUTTON A.-RESET *H62/H63	068443	1			380-415V 50HZ 3N~
COMPRESSOR RS80C1E-TF5-22	051958-33	1	1		200V 50/60HZ 3PH
COMPRESSOR RS80C1E-CAZ-224	051958-40	1	1	512	220-240V 50HZ 1PH
+CAPACITOR-RUN 20UF/370V	023606	1	1	103	220-240V 50HZ 1PH
+CAPACITOR-START 64-77UF/2	051960	1	1	103	220-240V 50HZ 1PH
+RELAY-START-COMPRESSOR	051957-40	1	1	103	220-240V 50HZ 1PH
COMPRESSOR RS80C1E-TFD-224	051958-58	1	1	512	380-415V 50HZ 3N~
CONTROLLER-MAG SAFETY INT	068439-03	1			380-415V 50HZ 3N~
DIAGRAM-WIRING *H62/H63*	067368-39	1	1		200V 50/60HZ 3PH
DIAGRAM-WIRING *H62*	067368-40	1	1	000	220-240V 50HZ 1PH
DIAGRAM-WIRING *H62*	067368-58A	1		000	380-415V 50HZ 3N~
DIAGRAM-WIRING *H62/H63	067368-58		1	000	380-415V 50HZ 3N~
DOOR A.-PARTIAL-1 SPT	X68450	1		103	380-415V 50HZ 3N~
ACTUATOR-CODED MAGNET	068440-A	1		103	380-415V 50HZ 3N~
NUT-8-32 ACORN SS	062388	2		103	380-415V 50HZ 3N~
O-RING-1-1/16 OD X.139W	020571	2		000	380-415V 50HZ 3N~
O-RING-5/8 OD X .103W	016030	1		000	380-415V 50HZ 3N~
PLUG-PRIME-METAL DOOR	067192	1		103	380-415V 50HZ 3N~
SCREW-8-32X3/4 SLTD ROUND	016533	2		000	380-415V 50HZ 3N~
VALVE A.-DRAW *H63*	X56119	1		103	380-415V 50HZ 3N~
HARNES-WIRE-COMP W/GRND	067365-G	1	1	103	200V 50/60HZ 3PH

+ Available Separately

DESCRIPTION	PART NUMBER	H62 QTY.	H63 QTY.	WARR. CLASS	REMARKS
HARNESS-WIRE 5472 MAIN PO	056884-33G	1	1	103	200V 50/60HZ 3PH
HARNESS-WIRE-MAIN POWER *	067405-33G	1		103	200V 50/60HZ 3PH
HARNESS-WIRE-MAIN POWER *	067405-58	1		103	380-415V 50HZ 3N~
HARNESS-WIRE-CTRL *0H62*CA	068498-58	1		103	380-415V 50HZ 3N~
HARNESS A.-WIRE-RS80 380V	X68464-2	1		103	380-415V 50 3N
HARNESS A.-WIRE-RS80 380V	X68464-1		1	103	380-415V 50 3N
HARNESS-WIRE 5472 COND FA	056893-G		1	103	220-240V 50HZ 1PH
HARNESS-WIRE H63 POWER 1/	067364-58		1	103	380-415V 50 3N
MOTOR-1/2 HP	059742-40	1	1	212	220-240V 50HZ 1PH / 380-415V 50HZ 3N~
MOTOR-FAN 75 WATT	050265-27		1		200V 50/60HZ 3PH
MOTOR-FAN 100W 220-240V 5	047178-34		1	103	220-240V 50HZ 1PH
OVERLOAD-THERMAL-3P-2.2-3	068442-35H	1			380-415V 50HZ 3N~
PANEL-FRONT-UPPER *0H62*	067305-SP	1			380-415V 50HZ 3N~
PANEL-SIDE-LEFT *0H62*	067500-SP2	1			380-415V 50HZ 3N~
PANEL-SIDE *H60*RIGHT	067722-SP1		1		200V 50/60HZ 3PH
PULLEY-AK23-5/8	016048	1	1	103	220-240V 50HZ 1PH / 380-415V 50HZ 3N~
PULLEY-AK69 X 5/8	051012	1	1	103	200V 50/60HZ 3PH

+ Available Separately



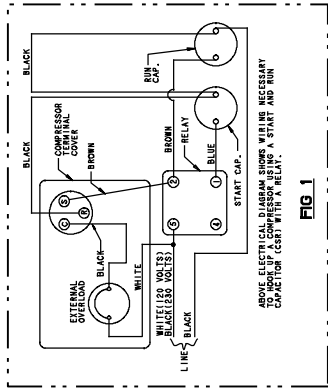
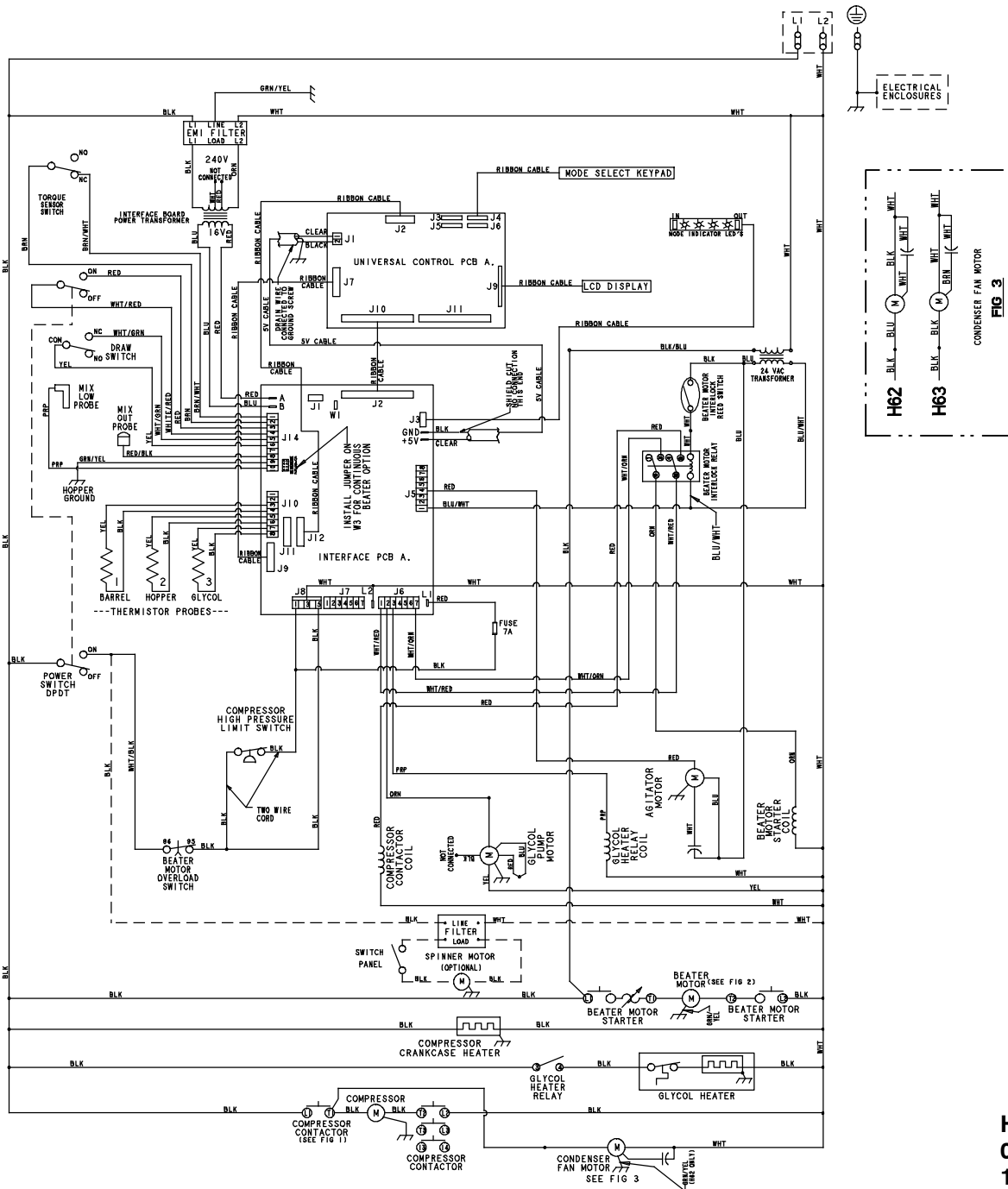

FIG 1

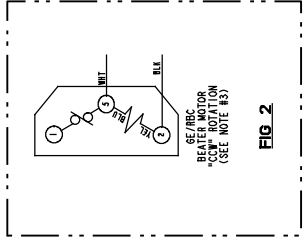

FIG 2

GROUND FRAME SECURITY

- NOTE:
1. STATIC ELECTRICITY MAY CAUSE DAMAGE TO SENSITIVE COMPONENTS. ELIMINATE STATIC ELECTRICITY BY TOUCHING GROUNDING UNIT BEFORE HANDLING SOLID STATE COMPONENTS.
  2. RED WIRE ON RIBBON CABLES AT EACH END.
  3. FOR "CCW" NOTATION OF GE/REC BEATER MOTOR FOR "CCW" NOTATION OF BEATER MOTOR AND INTERNAL YELLOW TO TERMINAL #2.

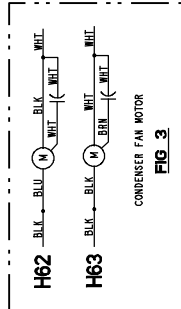
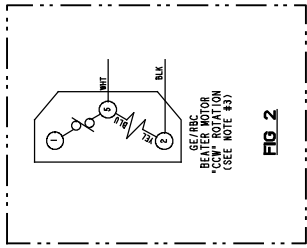
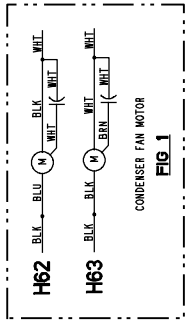

FIG 3

H62/H63  
067368-27  
10/11



**GROUND FRAME SECURELY**

- NOTE:
1. STATIC ELECTRICITY MAY CAUSE DAMAGE TO SOLID STATE COMPONENTS. ELIMINATE STATIC ELECTRICITY BY TOUCHING GROUNDED UNIT BEFORE HANDLING SOLID STATE COMPONENTS.
  2. RED WIRE ON RIBBON CABLES MUST BE CONNECTED TO PIN 1 AT EACH END.
  3. FOR CCW ROTATION OF BEATER MOTOR CONNECT INTERNAL YELLOW TO TERMINAL #2.

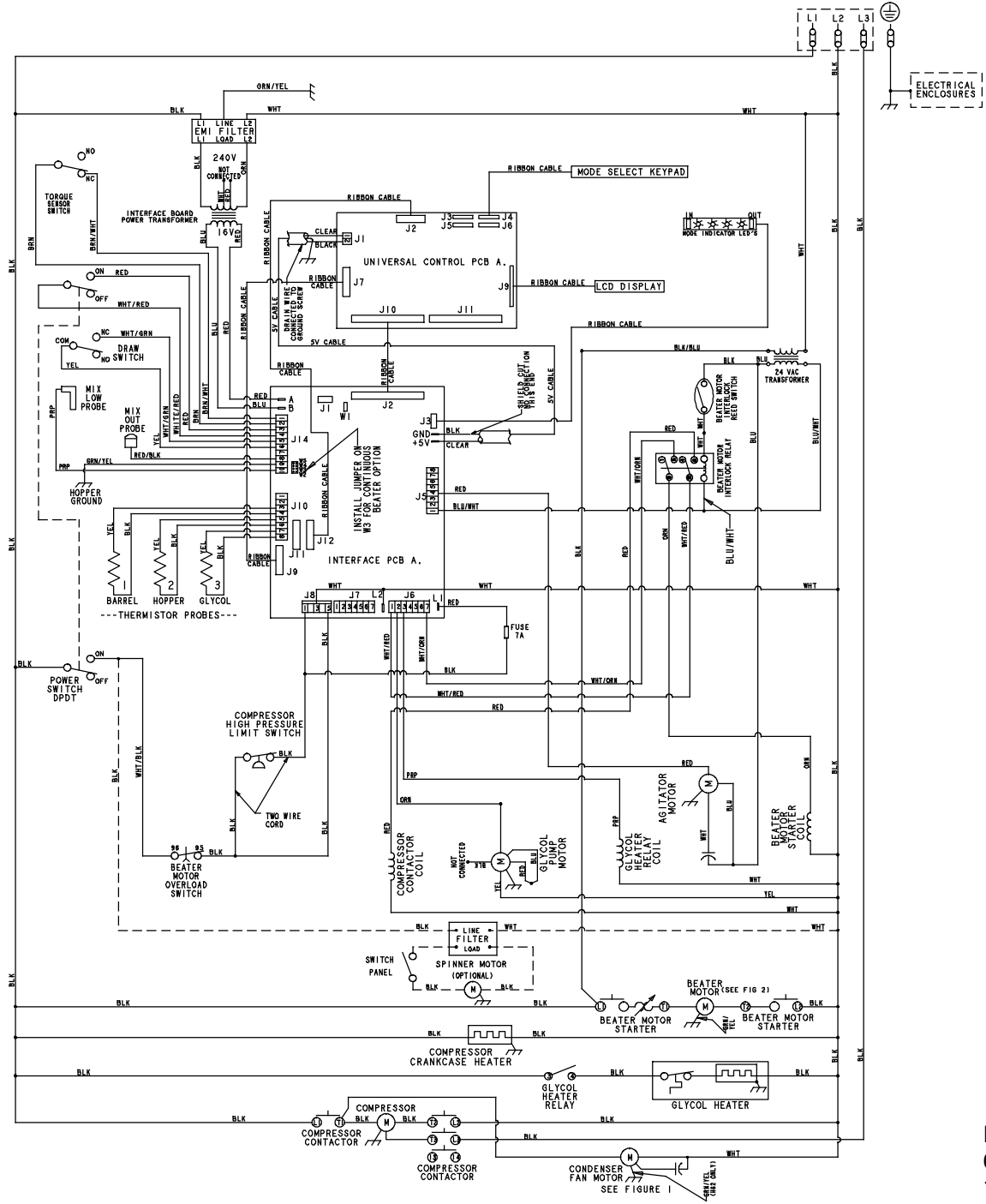

**H62/H63**  
**067368-33**  
**10/11**

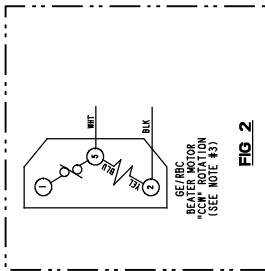
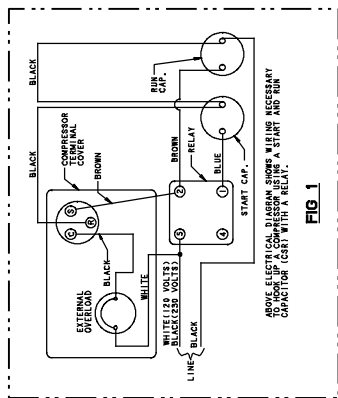
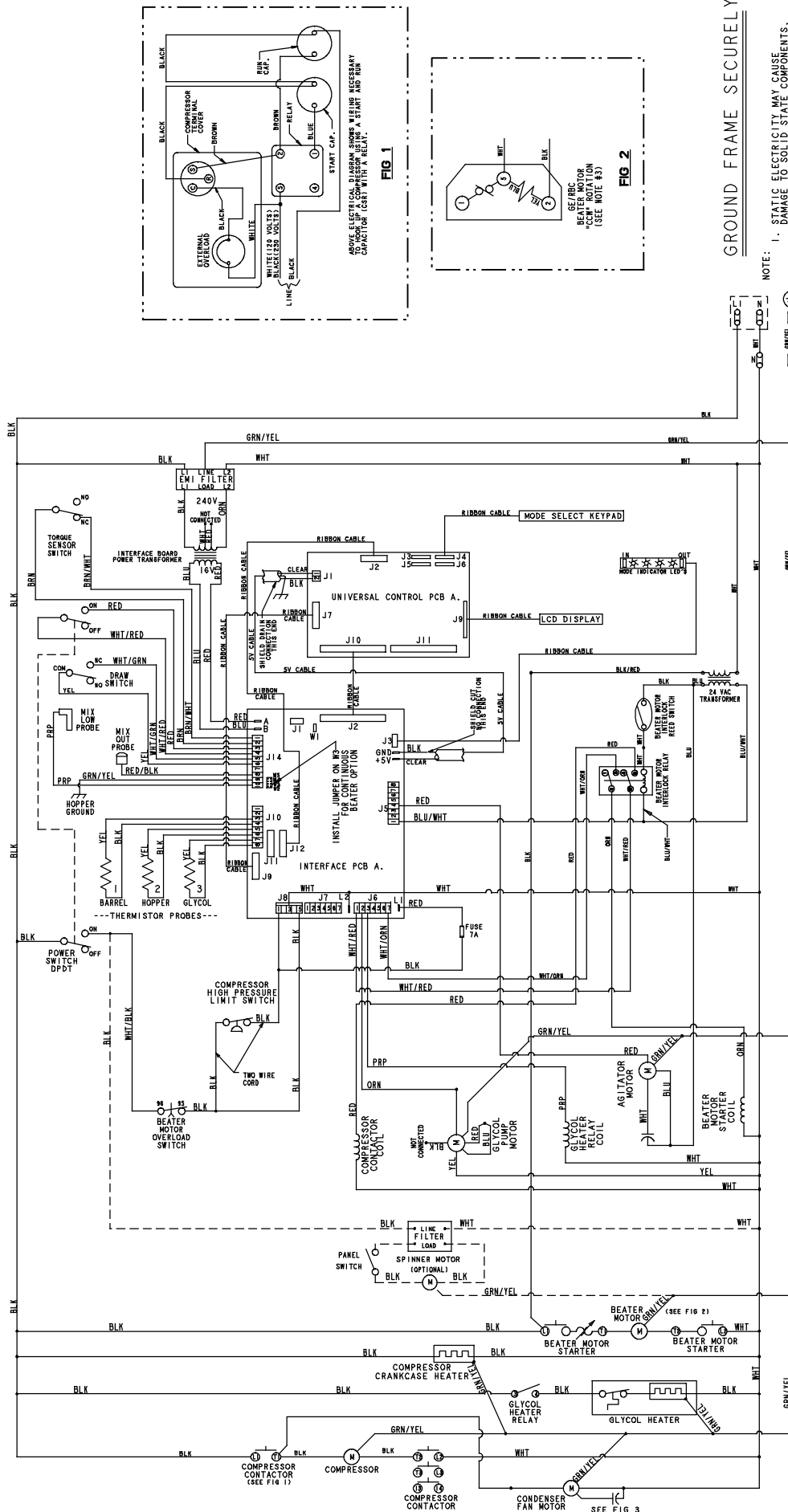

- NOTE:
1. STATIC ELECTRICITY MAY CAUSE DAMAGE TO THE MICROPROCESSOR. TO PREVENT THIS, TOUCHING GROUNDING POINTS OF THE UNIT BEFORE HANDLING SOLID STATE COMPONENTS.
  2. RED WIRE ON RIBBON CABLES MUST BE CONNECTED TO PIN 1 AT EACH END.
  3. FOR "CCW" ROTATION OF GE/RBC BEATER MOTOR, REVERSE THE WIRE TERMINALS AND INTERNAL YELLOW TO TERMINAL #2.

GROUND FRAME SECURITY

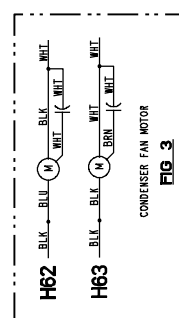

H62/H63  
 067368-40  
 10/11

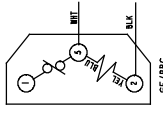
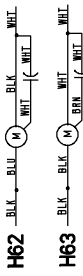
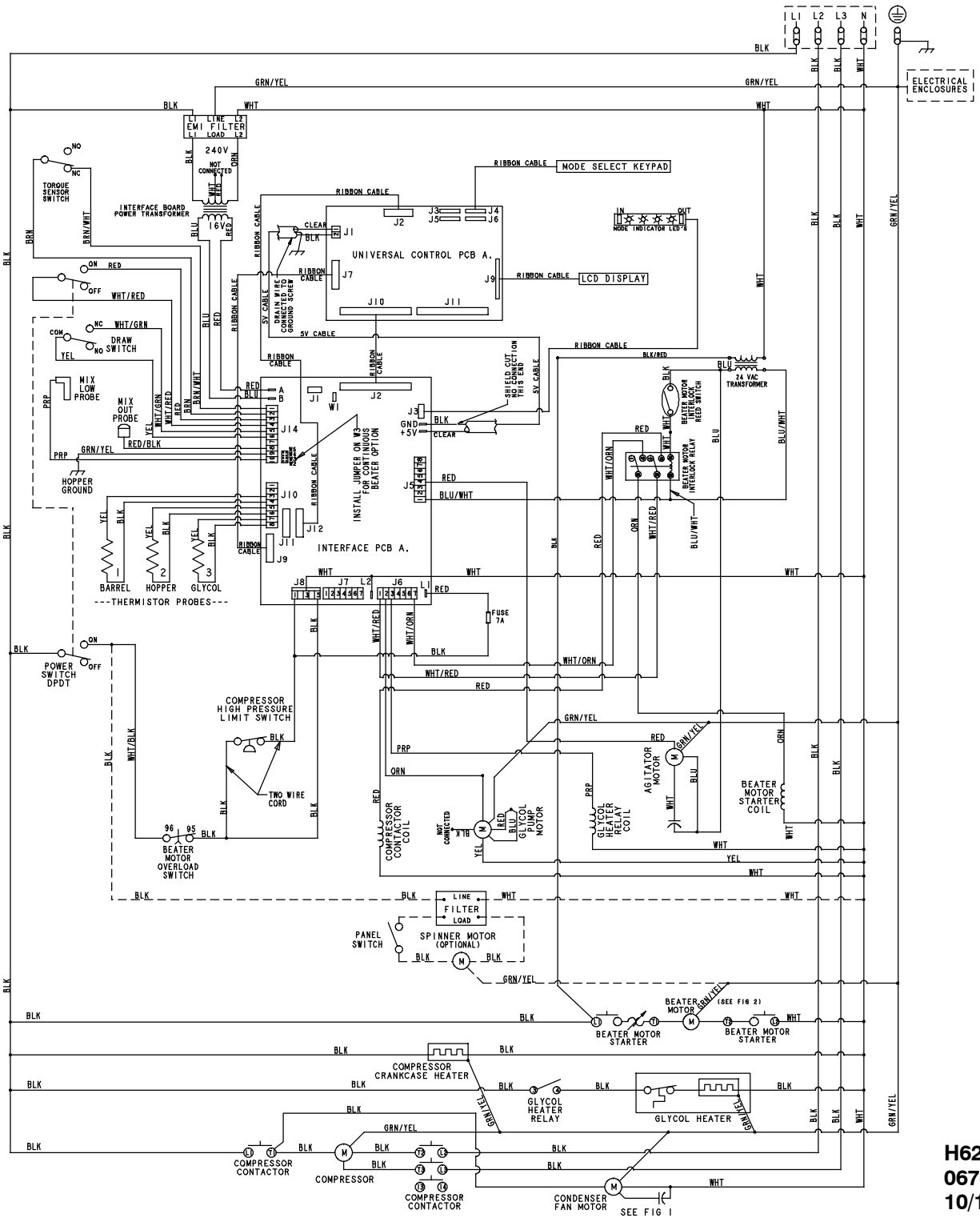

**GROUND FRAME SECURELY**

- NOTE:
1. STATIC ELECTRICITY MAY CAUSE DAMAGE TO SOLID STATE COMPONENTS. ELIMINATE STATIC ELECTRICITY BY TOUCHING COMPONENTS IN IT BEFORE HANDLING SOLID STATE COMPONENTS.
  2. RED WIRES ON RIBBON CABLES AT EACH END.
  3. FOR "CCW" ROTATION OF GE/REC BEATER MOTOR CONNECT INTERNAL BLUE TO TERMINAL #5 AND INTERNAL YELLOW TO TERMINAL #2.

**H62/H63**  
**067368-58**  
**10/11**

## Free Manuals Download Website

<http://myh66.com>

<http://usermanuals.us>

<http://www.somanuals.com>

<http://www.4manuals.cc>

<http://www.manual-lib.com>

<http://www.404manual.com>

<http://www.luxmanual.com>

<http://aubethermostatmanual.com>

Golf course search by state

<http://golfingnear.com>

Email search by domain

<http://emailbydomain.com>

Auto manuals search

<http://auto.somanuals.com>

TV manuals search

<http://tv.somanuals.com>