

TEAC

9A10355200

DAB
Digital Audio Broadcasting

CR-H255

CD/Receiver OWNER'S MANUAL

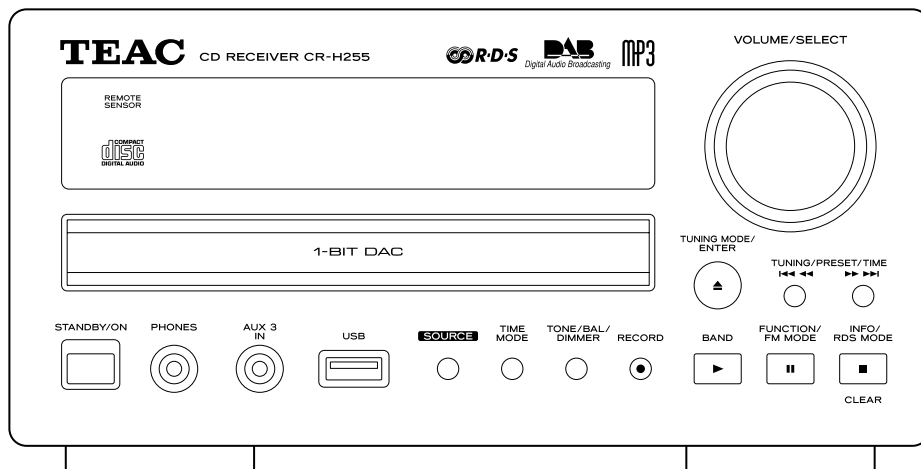

Contents

Thanks you for choosing TEAC. Read this manual carefully to get the best performance from this unit.

Before Use	3
Remote Control Unit	3
Compact Disc	4
MP3 and WMA	5
How to Reset the Settings to the Factory Defaults	5
Connections	6
Connecting Antennas (AM/FM)	8
Connecting Antennas (DAB)	9
Names of Each Control	10
Basic Operation	14
Listening to CD/MP3/WMA (discs)	16
Listening to a USB device	17
Search	17
Basic Playback	18
Repeat Playback	19
Programmed Playback	20
Shuffle Playback	21
Display	22
Time Display	22
Before Recording	23
Setting the Record Mode	23
Recording to USB	24
Delete a file from USB	24
Setting up your DAB Tuner	25
Auto Tuning	25
Using the Channel List	26
Using Function Control	27
Station order	27
Preset tune	28
DRC value	28
Manual tune	29
Changing Display Settings	30
Listening to FM/AM	32
Preset Tuning	33
RDS	35
PTY Search	36
About DAB	37

Setting the Clock	38
Setting the Timer	39
Sleep Timer	40
Listening to the External Sources	40
Specifications	41
Troubleshooting	42

Disposal of your old appliance

1. When this crossed-out wheeled bin symbol is attached to a product it means the product is covered by the European Directive 2002/96/EC.



2. All electrical and electronic products should be disposed of separately from the municipal waste stream via designated collection facilities appointed by the government or the local authorities.

3. The correct disposal of your old appliance will help prevent potential negative consequences for the environment and human health.

4. For more detailed information about disposal of your old appliance, please contact your city office, waste disposal service or the shop where you purchased the product.

Before Use

Read this before operation

- As the unit may become warm during operation, always leave sufficient space around the unit for ventilation.
- The voltage supplied to the unit should match the voltage as printed on the rear panel. If you are in any doubt regarding this matter, consult an electrician.
- Choose the installation location of your unit carefully. Avoid placing it in direct sunlight or close to a source of heat. Also avoid locations subject to vibrations and excessive dust, heat, cold or moisture.
- Do not place the unit on an amplifier/receiver.
- Do not open the cabinet as this might result in damage to the circuitry or electrical shock. If a foreign object should get into the set, contact your dealer or service agency.
- When removing the power plug from the wall outlet, always pull directly on the plug, never yank the cord.
- To keep the laser pickup clean, do not touch it, and do not forget to close the disc tray when not using the CD player.
- Do not attempt to clean the unit with chemical solvents as this might damage the finish. Use a clean, dry cloth.
- Keep this manual in a safe place for future reference.

DO NOT MOVE THE UNIT DURING PLAYBACK

During playback, the disc rotates at high speed. Do NOT lift or move the unit during playback. Doing so may damage the disc.

WHEN MOVING THIS UNIT

When changing places of installation or packing the unit for moving, be sure to remove the disc and return the disc table to its original position in the player. Then, press the power switch to turn the power off, and disconnect the power cord. Moving this unit with the disc loaded may result in damage to this unit.

CAUTION

The product shall not be exposed to dripping or splashing and that no object filled with liquids, such as vases, shall be placed on the product.

Do not install this equipment in a confined space such as a book case or similar unit.

Remote Control Unit

The provided Remote Control Unit allows the unit to be operated from a distance.

When operating the remote control unit, point it towards the REMOTE SENSOR on the front panel of the unit.

- Even if the remote control unit is operated within the effective range, remote control operation may be impossible if there are any obstacles between the unit and the remote control.
- If the remote control unit is operated near other appliances which generate infrared rays, or if other remote control devices using infrared rays are used near the unit, it may operate incorrectly. Conversely, the other appliances may operate incorrectly.

Battery Installation

1. Remove the battery compartment cover.
2. Insert two 'AAA' dry batteries. Make sure that the batteries are inserted with their positive '⊕' and negative '⊖' poles positioned correctly.
3. Close the cover.

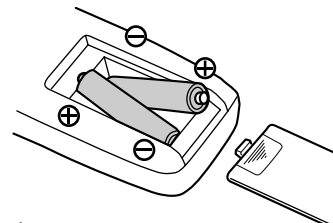

Battery Replacement

If the distance required between the remote control unit and main unit decreases, the batteries are exhausted. In this case replace the batteries with new ones.

Precautions concerning batteries

- Be sure to insert the batteries with correct positive '⊕' and negative '⊖' polarities.
- Use batteries of the same type. Never use different types of batteries together.
- Rechargeable and non-rechargeable batteries can be used. Refer to the precautions on their labels.
- When the remote control unit is not to be used for a long time (more than a month), remove the batteries from the remote control unit to prevent them from leaking. If they leak, wipe away the liquid inside the battery compartment and replace the batteries with new ones.
- Do not heat or disassemble batteries and never dispose of old batteries by throwing them in a fire.

Compact Disc

Discs which can be played on this unit:

- Conventional audio CDs bearing the CD-DA logo on the label:



- Properly finalized CD-R and CD-RW discs

Note:

- Depending on the quality of the disc and/or the condition of the recording, some CD-R/CD-RW discs may not be playable.
- Copy-protected discs and other discs which do not conform to the CD standard may not play back correctly in this player. If you use such discs in this unit, TEAC Corporation and its subsidiaries cannot be responsible for any consequences or guarantee the quality of reproduction. If you experience problems with such non-standard discs, you should contact the producers of the disc.
- Always place the disc on the disc tray with the label side uppermost. (Compact discs can be played or recorded only on one side.)
- To remove a disc from its storage case, press down on the center of the case and lift the disc out, holding it carefully by the edges.



How to remove the disc



How to hold the disc

- Should the disc become dirty, wipe the surface radially (from the center hole outward towards the outer edge) with a soft, dry cloth:



- Never use such chemicals as record sprays, antistatic sprays or fluid, benzene or thinner to clean the discs. Such chemicals will do irreparable damage to the disc's plastic surface.

- Discs should be returned to their cases after use to avoid dust and scratches that could cause the laser pickup to 'skip'.
- Do not expose discs to direct sunlight or high humidity and temperature for extended periods. Long exposure to high temperatures will warp the disc.
- Do not play any disc that is warped, deformed or damaged. Playing such discs may cause irreparable harm to the playing mechanisms.
- CD-R and CD-RW discs are more sensitive to the effects of heat and ultraviolet rays than ordinary CDs. It is important that they are not stored in a location where direct sunlight will fall on them, and which is away from sources of heat such as radiators or heat-generating electrical devices.
- Printable CD-R and CD-RW discs aren't recommended, as the label side might be sticky and damage the unit.
- Do not stick papers or protective sheets on the discs and do not use any protective coating spray.
- Use a soft oil-based felt-tipped pen to write the information on the label side. Never use a ball-point or hard-tipped pen, as this may cause damage to the recorded side.
- Never use a stabilizer. Using commercially available CD stabilizers with this unit will damage the mechanisms and cause them to malfunction.
- Do not use irregular shape CDs (octagonal, heart shaped, business card size, etc.). CDs of this sort can damage the unit:

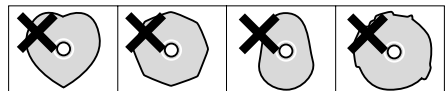

- If you are in any doubt as to the care and handling of a CD-R/CD-RW disc, read the precautions supplied with the disc, or contact the disc manufacturer directly.

MP3 and WMA

- This unit can play MP3 and WMA files recorded on a CD-R, CD-RW or USB storage device.
- File names of MP3 or WMA should be alphanumeric characters. This unit cannot display symbols and full-size or double-byte characters (such as Japanese, Chinese, etc.) correctly. Also, be sure to use the file extension. ('.mp3' for MP3 files, '.wma' for WMA files.)
- MP3 files are mono or stereo MPEG-1 Audio Layer 3 format. This unit can play MP3 files with sampling frequency 44.1 kHz or 48 kHz, bit-rate 320 kbps or less.
- This unit can play WMA files with sampling frequency 44.1 kHz, bit-rate 192 kbps or less. WMA means Windows Media Audio.
- Audio encoded at 128 Kbps should sound close to regular audio CD quality. Although this player will play lower bit-rate MP3 tracks, the sound quality becomes noticeably worse at lower bit-rates.

Discs

- The disc must be finalized in order to play.
- The CD-ROM must be ISO 9660 compatible.
- When more than 255 files are recorded on the disc, the unit might not be able to play it correctly.

USB

- This unit supports USB 1.1 FULL SPEED (12Mbps).
- This unit can play MP3 files recorded in various external USB storage devices such as USB flash memory, MP3 player or HDD. The HDD must be formatted FAT 16 or FAT 32, but not NTFS.
- When more than 2000 files are recorded on the USB memory, the unit might not be able to play it correctly.

How to Reset the Settings to the Factory Defaults

If the power supply is interrupted for 14 days or longer, all the settings kept in memory (such as preset stations and timer settings) will be erased.

It will take more than 3 days after plugging the power cord into the outlet to charge enough electricity for the memory backup function.

If you want to manually initialize the settings, hold down the FUNCTION/FM MODE button for more than 4 seconds in standby mode.

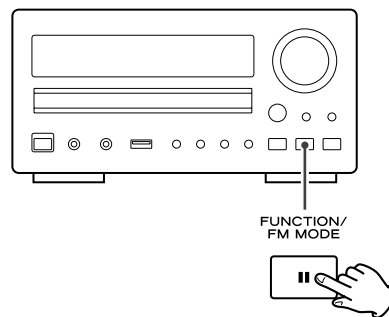

The unit will be turned on, and all the settings are reset to the default settings.

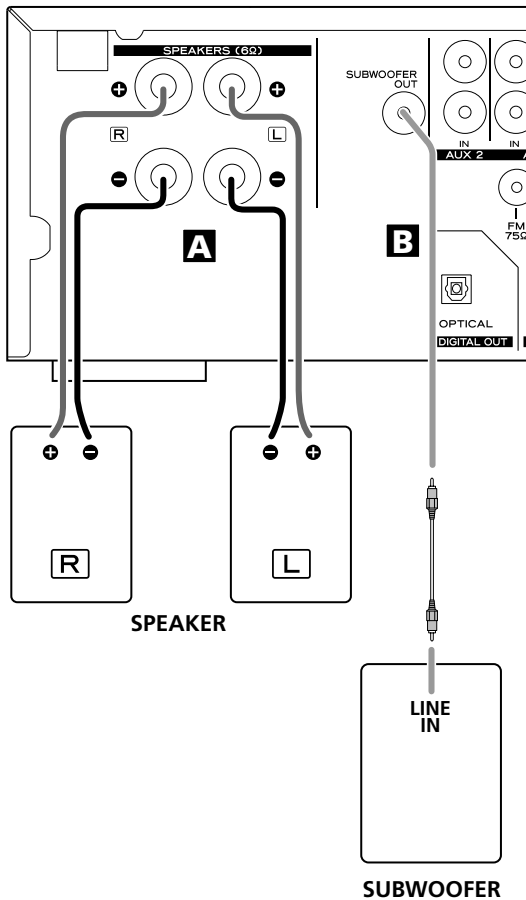

CAUTION

- Turn off the power of all the equipment before making connections.
- Read instructions of each component you intend to use with this unit.
- Be sure to insert each plug securely. To prevent hum and noise, do not bundle the connection cords with the power cord or speaker cord.

A Speaker Connections

Caution:

- To avoid damaging the speakers by a sudden high-level signal, be sure to switch the power off before connecting the speakers.
- Check the impedance of your speakers. Connect speaker with an impedance of 6 ohms or more.
- The amplifier's red speaker terminals are the ⊕ (positive) terminals and the black terminals are the ⊖ (negative) terminals. The ⊕ side of the speaker cable is marked to make it distinguishable from the negative side of the cable. Connect this marked side to the red ⊕ terminal and the unmarked side to the black ⊖ terminal.
- Prepare the speaker cords for connection by stripping off approximately 10 mm or less (no more as this could cause a short-circuit) of the outer insulation. Twist the wires tightly together to avoid tangles:

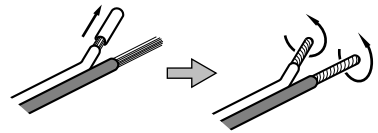

How to connect

1. Turn the terminal cap counterclockwise to loosen it. The speaker terminal caps cannot be fully removed from the base.
2. Insert the wire into the terminal fully and turn the terminal cap clockwise to securely connect it:

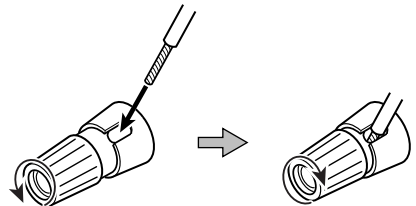

3. Make sure it is fastened firm by pulling the cable lightly.

B SUBWOOFER OUT jack

Connect a commercially available powered subwoofer.

- Subwoofer output will not be cut off, when the headphone jack is inserted.

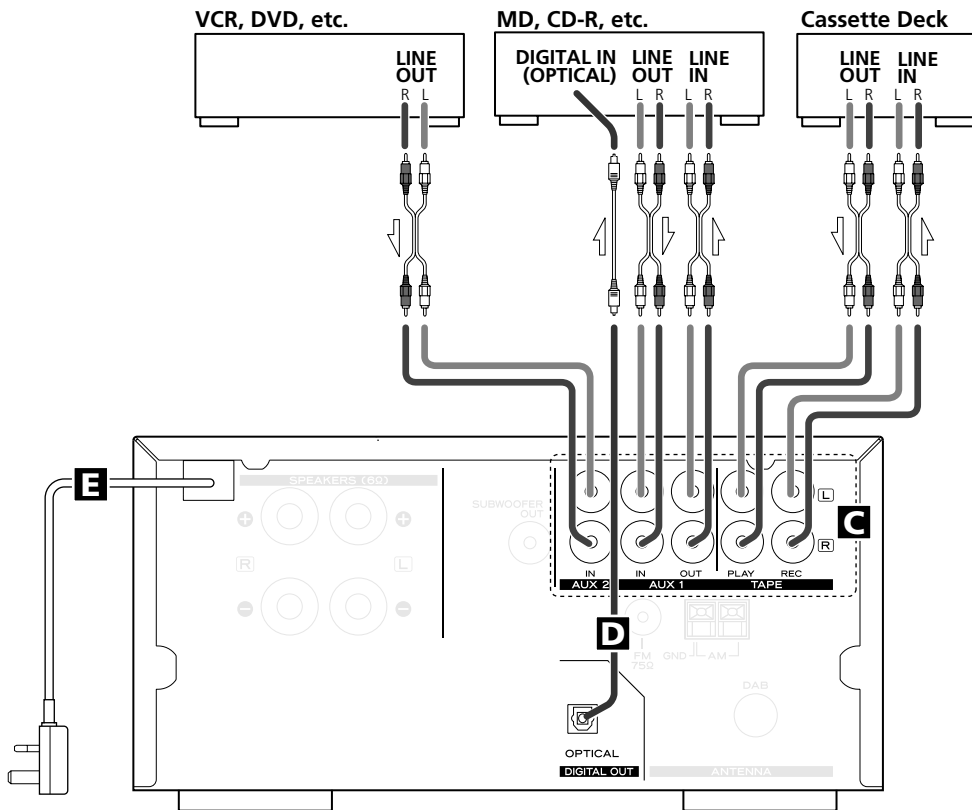

C TAPE/AUX jacks

Make sure to connect:

- white plug → white jack (L: left channel)
- red plug → red jack (R: right channel)

- Be sure to insert each plug securely. To prevent hum and noise, do not bundle the connection cords with the power cord or speaker cord.

D DIGITAL OUT terminal

Connect the component with an optical cable.

DIGITAL OUT → DIGITAL IN (MD, etc.)

- When inserting the plug of the optical cable, the protective shutter of the terminal will open and you should hear it click into position when fully inserted. Be careful that you do not force the plug, because this could result in damage to the protective shutter, the cable, or the unit itself.

E AC Power Cord

Plug this AC power cord into an AC wall socket.

Connecting Antennas (AM/FM)

AM Indoor Loop Antenna

The high-performance AM loop antenna provided with this unit is sufficient for good reception in most areas.

To stand the loop antenna on a surface, fix the claw to the slot in the antenna base.

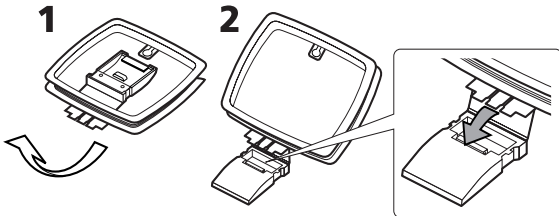

Connect the loop antenna's wires to the AM antenna terminals.

Place the antenna on a shelf or hang it on a window frame, etc., in the direction which gives the best reception. Keep all other wires such as power cords, speaker wires or interconnect wires as far away from the antenna.

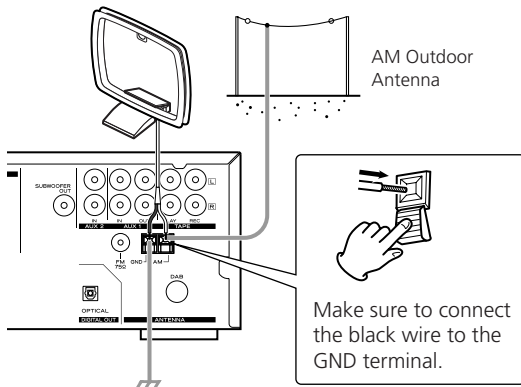

- If the AM loop antenna provided does not deliver sufficient reception (often due to being too far from the transmitter or in a concrete building, etc.), it may be necessary to use an outdoor AM antenna. Use either a high quality commercial AM antenna or, if not available, an insulated wire more than 5 m long, strip one end, and connect this to the terminal as shown. The antenna wire should be strung outdoors or indoors near a window. For better reception, connect the GND terminal to a reliable ground.

Note:

Even when using an outdoor AM antenna, do not disconnect the AM loop antenna.

FM Indoor Antenna

Connect the lead-type FM antenna to the FM 75Ω socket, extend the lead and tune the tuner to your favorite station (see page 32). Adjust the antenna in a suitable location like a window frame or wall until the reception is best and then affix the antenna in that position using thumb tacks, push pins or any other suitable means.

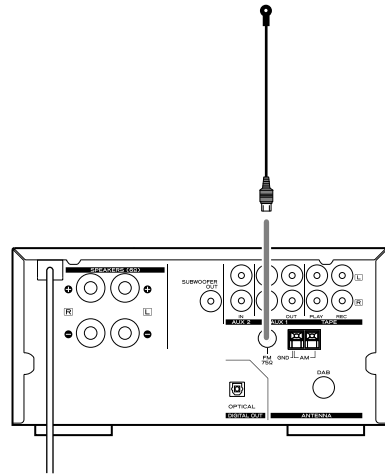

FM Outdoor Antenna

In an area where FM signals are weak, it will be necessary to use an outdoor FM antenna. Generally, a 3-element antenna will be sufficient; if you live in an area where the FM signals are particularly weak, it may be necessary to use one with 5 or more elements.

- Disconnect the FM indoor antenna when using an outdoor antenna.

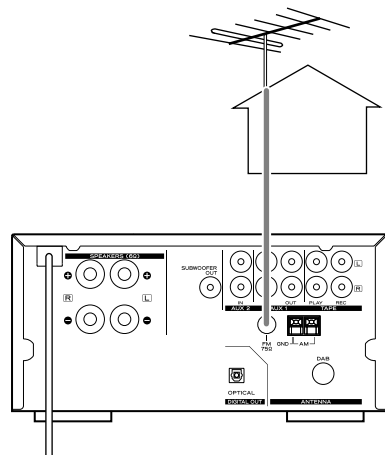

Connecting Antennas (DAB)

DAB Indoor Antenna

Connect the T-type DAB antenna to the DAB socket, extend the lead vertically and attach it to a window frame or wall with thumbtacks, or the like, where reception is best.

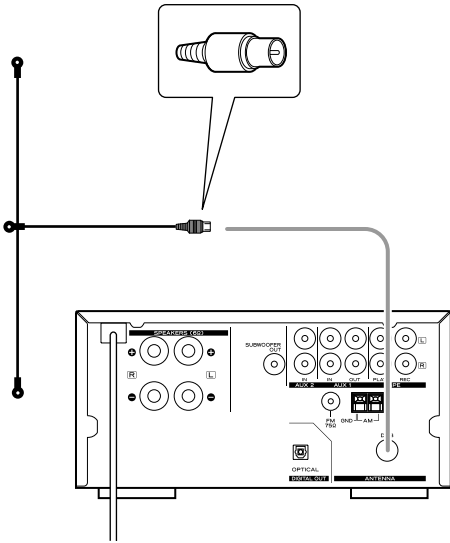

- You can check the antenna adjustment or positioning for the best reception by viewing the signal strength on the display.

The signal strength is displayed as a bar graph by pressing the ENTER button once.

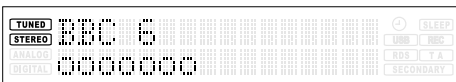

DAB Outdoor Antenna

In an area where DAB signals are weak, it will be necessary to use an outdoor DAB antenna. There are two main types available.

Dipole:

For use in marginal signal areas. This type of antenna is omnidirectional and should increase the strength of all DAB stations being received.

Multi-element antenna:

Also for use in marginal or poor signal areas. This type of antenna is directional and has high gain. This antenna needs to be pointed at the transmitter you want to listen to.

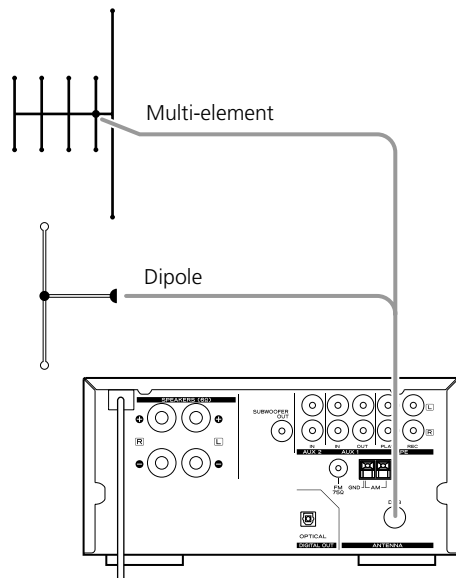

- It is possible to use a TV or FM antenna with your DAB tuner as this is normally mounted externally. This may give a stronger signal than a simple internal antenna, however it would not be tuned specifically for DAB reception.

You would need to change the plug on your TV/FM antenna to an F type, and it may also be necessary to use a signal booster to enhance the signal.

Names of Each Control 1

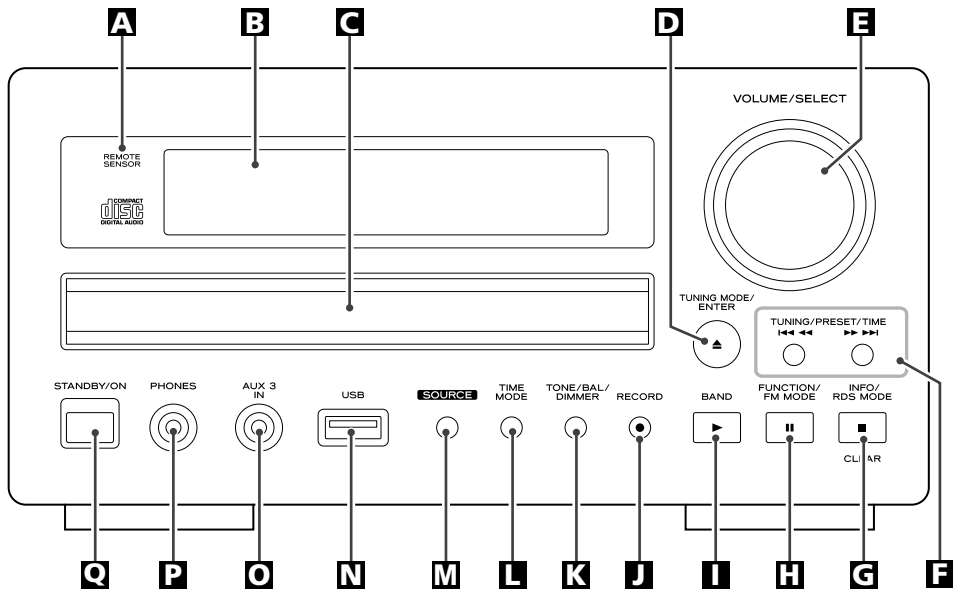

A Remote Sensor

When operating the remote control unit, point it towards the remote sensor.

B Display

C Disc tray

D OPEN/CLOSE (▲), TUNING MODE, ENTER

In CD mode, use this button to open and close the disc tray.

In FM or AM mode, use this button to select the tuning mode.

In DAB mode, use this button to enter the selection.

While setting the timer or the clock, use this button to set the time.

E VOLUME, SELECT

Turn this knob to adjust the volume.

Turn this knob to adjust the tone, balance and dimmer together with the TONE/BAL/DIMMER button.

F SKIP (◀◀◀/▶▶▶), TUNING, PRESET, TIME

In CD mode or USB mode, use these buttons to skip tracks.

In TUNER mode, use these buttons to tune in stations or select the preset stations.

While setting the clock or the timer, use these buttons to adjust the time.

G STOP (■), INFO, RDS MODE, CLEAR

In CD mode or USB mode, use this button to stop playback.

In DAB mode, this button is used to change the text content on the second line of the display, to show DLS (Dynamic Label Segment, info text supplied by each radio station), Programme type (classification given by the radio station i.e.: Pop music or Rock), Multiplex name (name of multiplex broadcaster), Time & date, Bitrate, Channel and frequency, Signal error rate or Software version.

In FM mode, this button is used to select the RDS mode.

Use this button also to cancel information entry or modes.

H PAUSE (II), FUNCTION, FM MODE

In CD mode or USB mode, use this button to pause playback.

In DAB mode, this button activates features such as station order, preset tune, DRC value, manual tune.

In FM mode, use this button to select stereo or monaural.

I PLAY (▶), BAND

In CD mode or USB mode, use this button to start playback.

In TUNER mode, use this button to select FM, AM or DAB.

J RECORD

Use this button to start recording to a USB device.

K TONE, BAL, DIMMER

Use this button to adjust the tone, balance and dimmer together with the VOLUME/SELECT knob.

L TIME MODE

Use this button to adjust the clock and to set a timer.

M SOURCE

Use this button to select a source.

N USB Jack

Use to connect the external USB storage device to the unit.

O AUX 3 IN Jack

Use to connect the output of an external source.

P PHONES

For private listening, insert the headphones plug into this jack, and adjust the volume by turning the VOLUME/SELECT knob.

Q STANDBY/ON

Press this button to turn the unit on or standby.

The standby indicator surrounding the STANDBY/ON button lights when the unit is in the standby mode. When the unit is turned on, it goes off.

The equipment draws nominal non-operating power from the AC outlet with its STANDBY/ON switch in the STANDBY position.

Names of Each Control 2

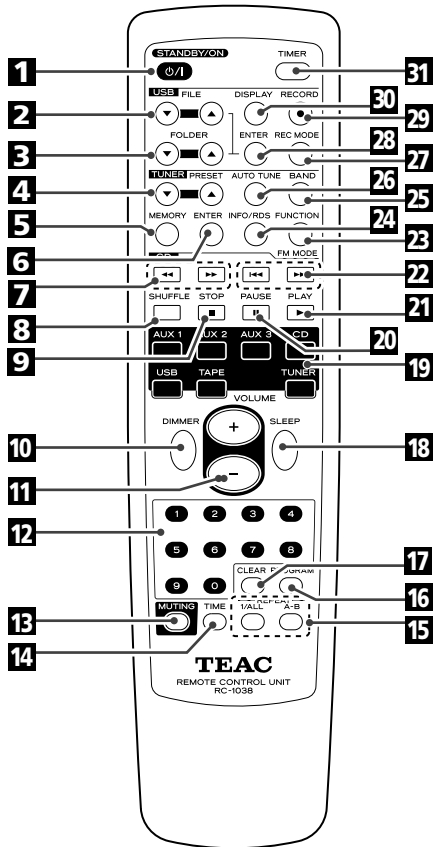

1 STANDBY/ON

Press this button to turn the unit on or standby.

2 FILE (▼,▲)

Use these buttons to select a file of MP3/WMA.

3 FOLDER (▼,▲)

Use these buttons to select a folder of MP3/WMA.

4 PRESET (▼,▲)

In TUNER mode, use these buttons to select the preset stations.

5 MEMORY

In TUNER mode, press this button to put the presently tuned-in station in memory.

In TUNER mode, press and hold for 3 seconds to place the stations in memory automatically.

6 ENTER (TUNER)

In DAB mode, use this button to enter the selection.

7 SEARCH (◀◀/▶▶)

During playback of CD or USB, use these buttons to search the part you want to listen to.

8 SHUFFLE

In CD mode or USB mode, use this button to enter the shuffle playback mode.

9 STOP

In CD mode or USB mode, use this button to stop playback.

10 DIMMER

Use this button to dim the display.

11 VOLUME

Use these buttons to adjust the volume.

12 Numeric buttons

Use these buttons to select a track number or a preset channel.

Press the CD, USB or TUNER button to select the mode, and then press the numeric buttons.

For instance, to select track number 35, first press the CD button, and then press '3' and '5'.

- When you use the numeric buttons, press the input selector button of the remote control first.

13 MUTING

Use this button to mute the sound.

14 TIME

During audio CD playback, use this button to change the time display.

15 REPEAT A-B

Use this button to set the point for A-B repeat.

REPEAT 1/ALL

Use this button to select the repeat mode.

16 PROGRAM

In CD mode or USB mode, use this button to enter the program mode. In program mode, use this button to enter the selection.

17 CLEAR

Use this button to clear a program.
In the USB mode, use this button to delete recorded files.

18 SLEEP

Use this button to set the sleep timer.

19 Input selector

Use these buttons to select a source.

20 PAUSE (II)

In CD mode or USB mode, use this button to pause playback.

21 PLAY (▶)

In CD mode or USB mode, use this button to start playback.

22 SKIP (◀◀ / ▶▶)

In CD mode or USB mode, use these buttons to skip tracks.

23 FUNCTION, FM MODE

In DAB mode, this button activates features such as station order, preset tune, DRC value, manual tune.
In FM mode, use this button to select stereo or monaural.

24 INFO/RDS

In DAB mode, this button is used to change the text content on the second line of the display, to show DLS (Dynamic Label Segment, info text supplied by each radio station), Programme type (classification given by the radio station i.e.: Pop music or Rock), Multiplex name (name of multiplex broadcaster), Time & date, Bitrate, Channel and frequency, Signal error rate or Software version.
In FM mode, this button is used to select the RDS mode.

25 BAND

In TUNER mode, use this button to select FM, AM or DAB.

26 AUTO TUNE

In DAB mode, press this button to activate auto location of all available DAB services. Press once for UK services or, hold for longer than 2 seconds to activate international search.

27 REC MODE

In USB mode, use this button to select Record mode.

28 ENTER (USB)

In USB mode or CD (MP3, WMA disc) mode, use this button to enter the selection.

29 RECORD

Use this button to start normal recording.
This function is not available in USB mode.

30 DISPLAY

During MP3/WMA playback, use this button to bring up the display.

31 TIMER

Use this button to turn on or off the timer function.
After setting the timer, press this button once more to set USB timer recording.
One minute before the set time the unit turns on and recording begins at the set time.

Basic Operation

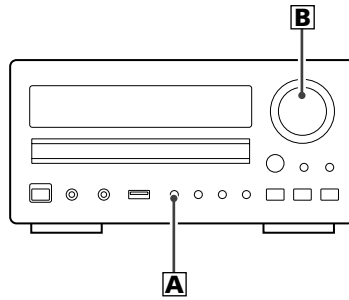

A How to select SOURCE

Every time the SOURCE button is pressed, the mode is changed as follows:



Or press the CD, USB, TAPE, AUX 1/2/3 or TUNER button on the remote control to select the source directly.

B Adjust the volume

To protect speakers from a sudden high-level signal, gradually turn up the volume to the required level with the VOLUME knob.

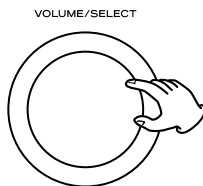

C Muting

To cut the sound temporarily, press the MUTING button. To cancel muting, press the MUTING button again or change the volume setting.

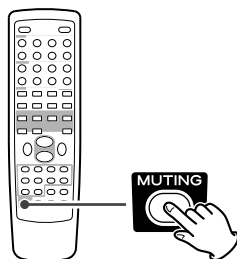

D Dimmer

Press the DIMMER button to dim the display. Press the button again to cancel the dimmer function.

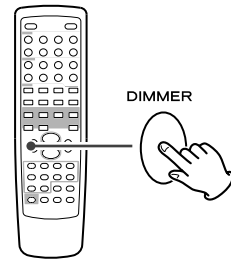

- This function will be cancelled when the unit is turned off.
- You can also adjust the dimmer on the front panel control (see next page).

E Listening through headphones

Insert the headphone plug into the PHONES jack, and adjust the volume. The sound from speakers will be cut off.

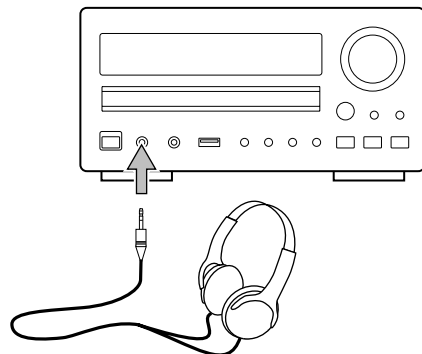

- Subwoofer output will not be cut off, when the headphone jack is inserted.

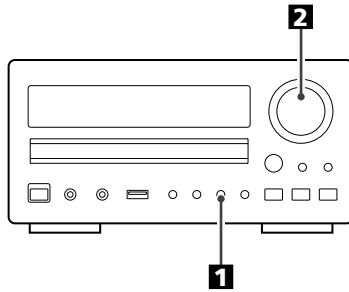

How to adjust TONE/BALANCE/DIMMER

1 Press the TONE/BAL/DIMMER button.

Each time the TONE/BAL/DIMMER button is pressed, the mode is changed as follows:

TONE/BAL/
DIMMER

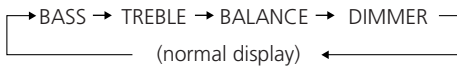

2 Within 3 seconds, turn the VOLUME/SELECT knob to change the setting.

VOLUME/SELECT

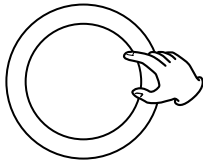

Bass control

This control is used for adjusting the level of the low frequency sound range.

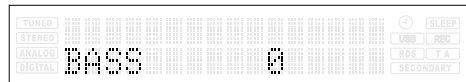

Treble control

This control is used for adjusting the level of the high frequency sound range.

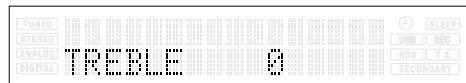

Balance control

This control is used for adjusting balance of the volume level between the left and right channels.

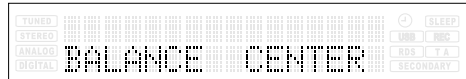

Dimmer control

This control can be used to dim the display panel or to return it to normal.

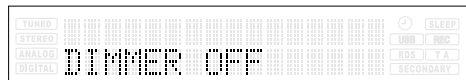

- You can also adjust the dimmer using the remote control (see previous page).

Listening to CD/MP3/WMA (discs)

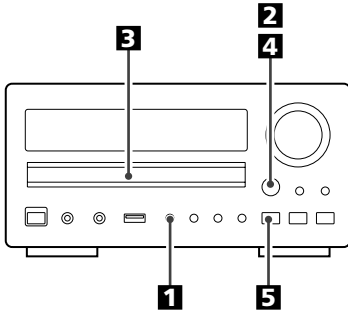

1 Press the **SOURCE** button repeatedly to select 'CD'.

'No Disc' will be displayed if no disc is set.



2 Press the **OPEN/CLOSE** button (▲).



3 Place a disc on a tray with the printed surface up.

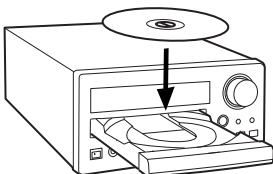

4 Press the **OPEN/CLOSE** button (▲) to close the tray.

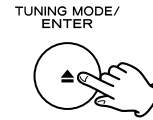

(Audio CD)

The total number of the tracks and total play time of the disc is displayed.



(MP3/WMA disc)

The total number of files of the disc is displayed.

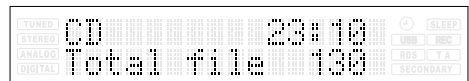

5 Press the **PLAY** button (▶).

Playback starts from the first track/file.

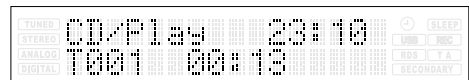
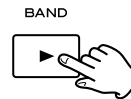

- When a disc is on the disc tray, selecting the CD mode will start playback.
- If the source is set to 'CD', the unit will automatically start playback when you turn on the unit next time.
- File types that can be played on this unit: MP3, WMA

Listening to a USB device

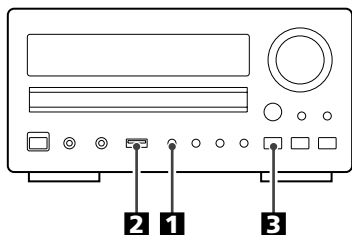

You can play MP3/WMA files by connecting various external USB storage devices such as USB flash memory.

1 Select USB function by pressing the SOURCE button repeatedly.

'Not connected' will be displayed if no USB device is connected.



2 Connect the external USB storage device to the unit.

When an HDD device is connected to this unit, it may take several minutes to display the number of files.

3 Press the PLAY button (▶).

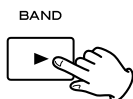

How to disconnect USB

Hold down the TIME MODE button for more than 4 seconds until 'Pls, remove USB' blinks on the display and then disconnect the USB device.

Search

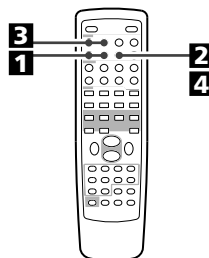

You can select a desired directory and an MP3 or WMA file during playback or when stopped.

1 Press the FOLDER buttons (▼/▲) to select a directory.

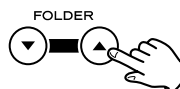

2 Press the ENTER button.



3 If you want to select a file, press the FILE buttons (▼/▲).

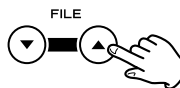

- The selection moves within the directory.

4 Press the ENTER button.



Basic Playback

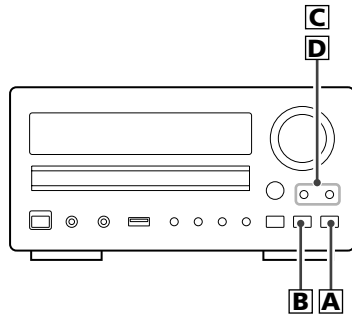

A To stop playback

Press the STOP button (■) to stop playback.

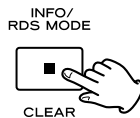

B To suspend playback temporarily (pause mode)

Press the PAUSE button (||). Playback stops at the current position.

To resume playback, press the PLAY button (▶) or PAUSE button (||).



C To skip to the next or a previous track/file

Press the ◀◀◀ or ▶▶▶ button several times until the desired track/file is found. The selected track/file will be played from the beginning.

On the remote control press the ◀◀ or ▶▶ button.

- When the ◀◀◀ button is pressed once during playback, the track/file being played will be played from the beginning.

To return to the beginning of the previous track/file, press the ◀◀◀ button twice.

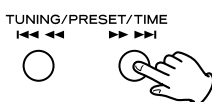

D Search for a part of a track/file

During playback, hold down the ◀◀◀ or ▶▶▶ button and release it when the part you want to listen to is found.

On the remote control use the ◀◀ or ▶▶ button.

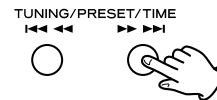

E Direct Playback

While in stop or playback mode, you can use the numeric buttons of the remote control to select a track/file.

- When you use the numeric buttons, press the input selector button of the remote control first.

Press the numeric buttons to select a track/file. Playback starts from the selected track/file.

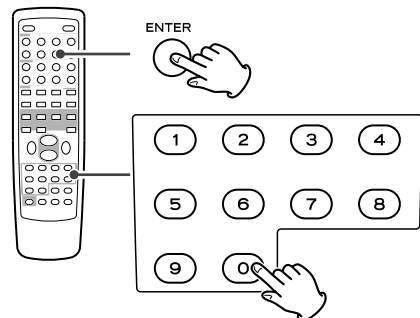

For instance, to select track/file number 35, press '3', '5'.

To select numbers less than 10, press the number and then the ENTER button. As an example, to select number 5, press '5' and the ENTER button. (Optionally, you may press just the number '5' and then wait a few seconds.)

Repeat Playback

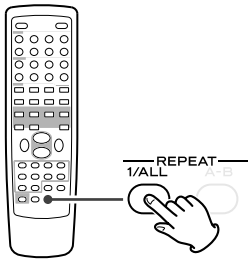

Every time the REPEAT 1/ALL button is pressed, the mode is changed as follows:

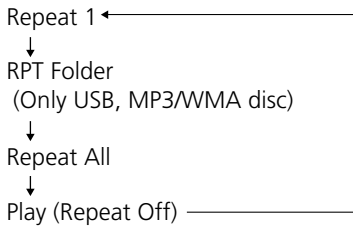

Repeat One Track [Repeat 1]

The track/file being played will be played repeatedly. If you select another track/file in Repeat 1 mode, the track/file you selected will be played repeatedly.

Repeat Folder [RPT Folder] (Only USB, MP3/WMA disc)

All the tracks or files in the folder will be played repeatedly.

Repeat All

All the tracks or files will be played repeatedly.

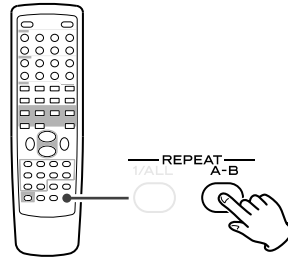

Repeat A-B

This function allows repeat playback of any desired portion of the disc.

1 Designate the point at which repeat playback should start by pressing the A-B button.

'Repeat A-' lights up and 'B' blinks.

2 When the point at which repeat playback should end is reached, press the A-B button again.

'Repeat A-B' lights up.

The designated point with A-B button will be played back repeatedly.

- To return to normal play, press A-B button until 'Repeat A-B' disappears from the display.
- It must be more than 3 seconds between A and B.

Programmed Playback

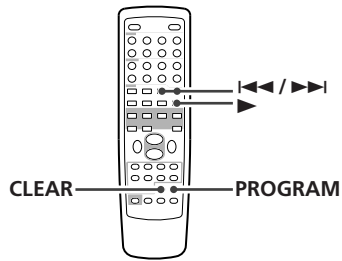

- This function allows you to program up to 32 tracks or files for playback in any desired order.

1 Press the PROGRAM button in the stop mode.

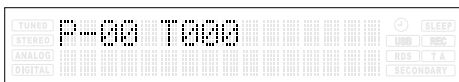

2 Select the desired track or file by pressing the I<</> or >>I button and press the PROGRAM button to enter.

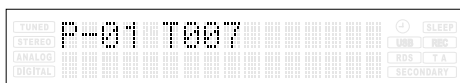

Repeat this step to store other tracks.

- If you attempt to program more than 32 tracks or files, 'P-FULL' is displayed and no more can be programmed.

3 Press the PLAY button (▶) to start programmed playback.

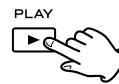

- The programmed contents for audio CDs are not lost even if the unit is turned off, but they are lost when the disc tray is opened or the USB device is disconnected.
- The unit will stop automatically when the playback of all the programmed contents is finished, and the program contents disappears from the display, but they are not lost.
- To start program playback again, press the PROGRAM button and the PLAY button (▶).

To check the programmed order

Press the PROGRAM button repeatedly in the stop mode. The track/file number and program number will be shown on the display.



To delete a track/file from the program

In the stop mode, press the PROGRAM button repeatedly until the program number to be deleted appears on the display, then press the CLEAR button. The selected track/file is deleted from the program.

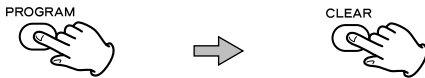

To clear the program

1. In the stop mode, press the PROGRAM button.
2. Hold down the CLEAR button for more than 4 seconds.

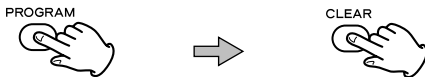

- If the OPEN/CLOSE button (▲) is pressed, the programmed contents will also be cleared.

To add a track/file to the program

In the stop mode, press the PROGRAM button repeatedly until the program number you want to insert a track/file appears on the display. If you want to add a track/file to the end of the program, press the PROGRAM button repeatedly until 'P-End' briefly appears on the display.

Then select a track/file number pressing the ◀◀ or ▶▶ buttons and press the PROGRAM button to enter. The track/file is added to the program.

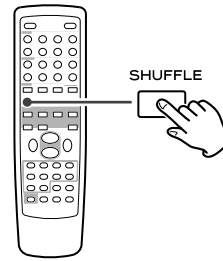

Press the SHUFFLE button in the stop or play mode.

The tracks or files will be played randomly.

'CD/Random play' or 'USB/Random play' is displayed.

- If you press the ▶▶ button during shuffle playback, next track will be randomly selected and played. If you press the ◀◀ button, the currently played track/file will be played from the beginning. A track/file cannot be replayed during shuffle playback.
- To stop shuffle playback, press the SHUFFLE button or the STOP button (■).

Display

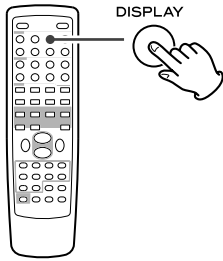

During MP3/WMA playback, press the DISPLAY button repeatedly to change what information is displayed.

Default display (scrolling):

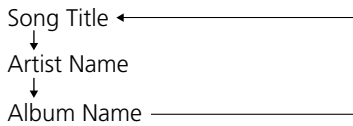

Display changes as follows:

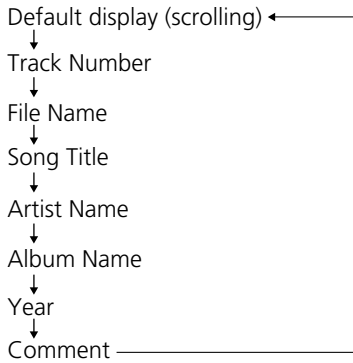

Time Display

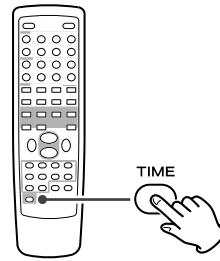

When playing back an audio CD, each time the TIME button is pressed the display changes as follows:

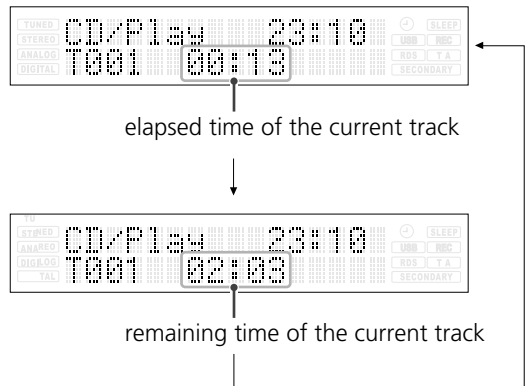

Before Recording

This unit can record musics from CDs, cassette tapes and radio, on USB memory devices, as MP3 or WMA files.

CAUTION

- Do not disconnect the USB storage device during recording.
Do not disconnect the power cord during recording. It may cause damage to the products.
- Adjust the volume of the external audio source to suitable level before recording. If not, the recording quality becomes poor.

Note

- The recorded files are saved in the AUDIO folder.
 - The FILE NAME is fixed up automatically in regular sequence like 'AUDIO001.MP3', 'AUDIO002.MP3',
- For Example:
If there are 'AUDIO004.MP3' and 'AUDIO009.MP3' files in the AUDIO folder, and you make a recording, a new file will be 'AUDIO010.MP3'.

Setting the Record Mode

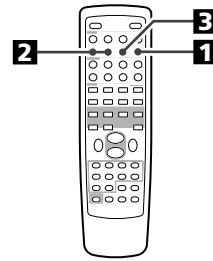

You can select the desired record mode.

1 In USB mode, press the REC MODE button.



2 Press the FOLDER buttons (▼/▲) to select a desired recording mode.

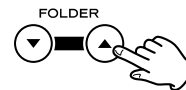

Each time you press the FOLDER button (▼/▲), the recording mode changes as follows:

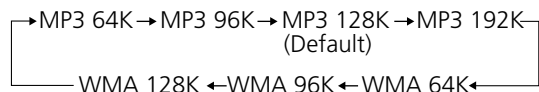

3 Within 3 seconds, press the ENTER button.



Bitrate

Value indicating the amount of data compression progress in a per second.

The higher bitrate is the larger the amount of data.

This does mean that the sound is high quality.

128Kbps/s is recommended for listening enjoyment.

Recording to USB

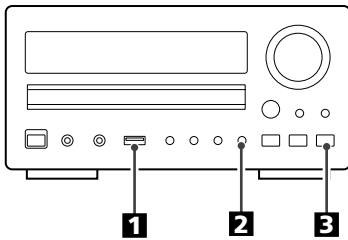

You can record a source of CD, MP3/WMA disc, cassette tape, radio broadcast and external device to the external USB storage device as MP3/WMA files.

1 Connect the external USB storage device to the USB port on the front panel of the unit.

2 Press the RECORD button and recording starts.



- In CD mode, playback starts automatically.
- If you want to record the tracks in a desired order, program the tracks before recording.

3 If you want to stop recording, press the STOP button (■).

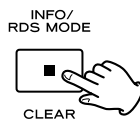

Press the STOP button (■) once more to stop playback of the disc.

You cannot record to an external storage device if there is no free space or the device is locked.

Delete a file from USB

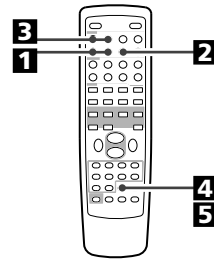

1 In the stop mode, press the FOLDER buttons (▼/▲) to select a directory.

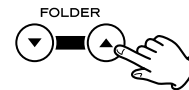

2 Press the ENTER button.



3 Press the FILE buttons (▼/▲) to select the desired file.

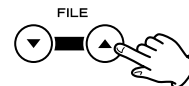

4 Press the CLEAR button for more than 4 seconds.



'Delete?' is displayed.

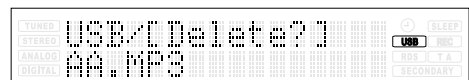

5 Within 3 seconds, press the CLEAR button again.



- The delete mode will be cancelled, if you don't press the CLEAR button within 3 seconds.

Setting up your DAB Tuner

The first time you listen to the DAB radio, it will scan for DAB channels and build a channel list.

To enter the DAB mode, turn the unit on, and select DAB by pressing the SOURCE button and the BAND button.

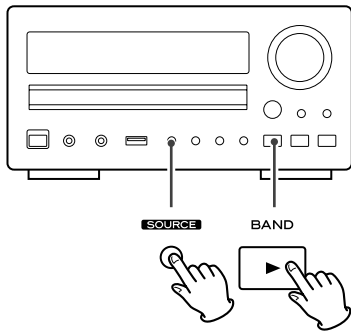

The following screen will display for 2 seconds.

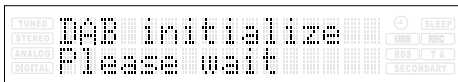

The unit will scan for broadcast services in the local area and add them to the channel list as they are found. The scan should take about 10 seconds.



As channels are added to the channel list the number of channels found is displayed.

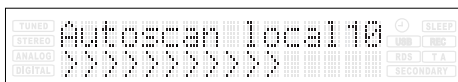

After broadcast services have been found the channels are listed in alphanumeric order.

- If no broadcast services are found, please check that the antenna is correctly connected to the unit.

Auto Tuning

If you move the unit to a new area or you want to check to see if there are new channels available in your area, you can scan to find new channels automatically.

Press the AUTO TUNE button.

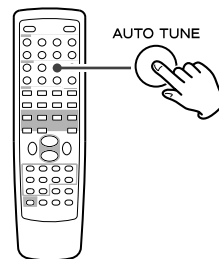

The unit will scan for any new channels and add the channels found to the channel list.

- Press and hold the AUTO TUNE button for longer than 2 seconds to activate international search.

Using the Channel List

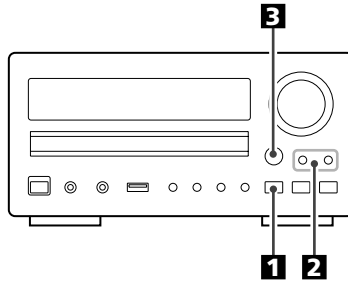

Follow the steps below to tune in and listen to the channels found by the unit.

1 Select DAB by pressing the BAND button.

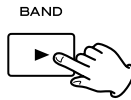

2 Press the TUNING/PRESET/TIME button to find the channel in the channel list.

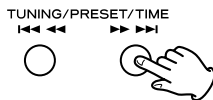

The current channel is displayed on the first line and the changing list is displayed on the second line.

3 When you have found a channel that you want to listen to, press the ENTER button once.



The channel is tuned in and channel information is displayed.

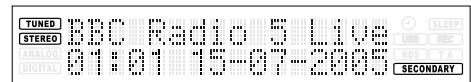

- To display the signal strength of a channel, press the ENTER button. The signal strength is displayed. Press the ENTER button once again to cancel the signal strength display.
- Channels are displayed in alphanumeric order in the channel list, with numbers coming first. So, stations such as 6 Music from the BBC will be listed early in the list.
- If a channel is no longer broadcasting or the unit is moved out of the area of a broadcast channel, the unit will no longer be able to tune in the channel. If the channel cannot be tuned in a question mark (?) is displayed in front of the channel name. If you select this channel to tune in by pressing the ENTER button, 'No stations Available' is displayed.

Using Function Control 2

Preset tune

Use this option to select the DAB preset station.

- 1** While listening to a DAB broadcast press the **FUNCTION/FM MODE** button.

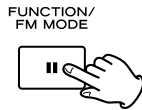

- 2** Press the **TUNING/PRESET/TIME** button until 'Preset tune' is displayed in the second line of the display.

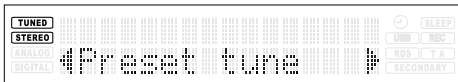
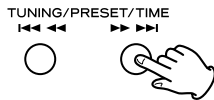

- 3** Press the **ENTER** button.



The currently tuned station is displayed.

- 4** Press the **TUNING/PRESET/TIME** button until the desired preset station is displayed.

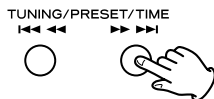

- 5** Press the **ENTER** button to select the preset station.

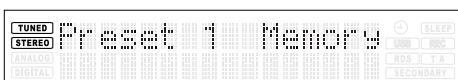

DRC value

This option sets the Dynamic Range Control (DRC) value to be applied to received broadcasts. DRC is used to reduce the range between high and low volumes of audio and is sometimes applied at the broadcast source. Pop music may have a high value of DRC applied, appropriate for constantly high listening levels, while classical music broadcasts may have no DRC applied to allow the listener to hear the full dynamic range of the source volume.

There are three values of DRC you can apply.

- 0 : None
- 1/2 : Medium
- 1 : Maximum

- 1** While listening to a DAB broadcast press the **FUNCTION/FM MODE** button.

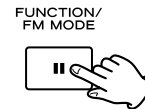

- 2** Press the **TUNING/PRESET/TIME** button until 'DRC value' is displayed in the second line of the display.

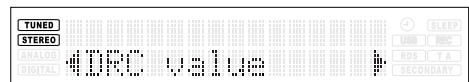
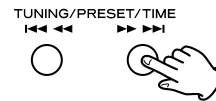

- 3** Press the **ENTER** button.



- 4** Press the TUNING/PRESET/TIME button until the desired level of DRC is displayed in the second line of the display.

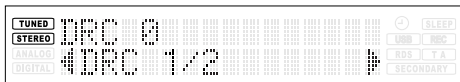
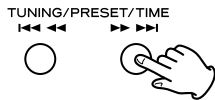

- 5** Press the ENTER button.



Manual tune

This option allows you to manually tune in a channel and view a continuously updated display of the strength of the signal. This may be useful when adjusting or positioning an antenna for better reception.

- 1** While listening to a DAB broadcast press the FUNCTION/FM MODE button.



- 2** Press the TUNING/PRESET/TIME button until 'Manual tune' is displayed in the second line of the display.

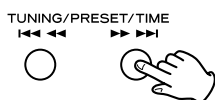

- 3** Press the ENTER button.



'Manual tune' is displayed on the first line of the display.

- 4** Press the TUNING/PRESET/TIME button to find the channel.

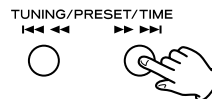

- 5** Press the ENTER button when the channel you wish to tune in is displayed in the second line of the display.



The signal strength indicator is displayed.

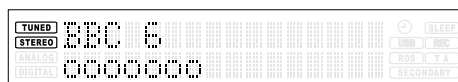

- 6** While viewing the indicator, adjust or reposition the antenna until the best reception is indicated.

- 7** Press the ENTER button to cancel Manual tune and resume normal reception.



Changing Display Settings

You can choose the type of information displayed in the second line of the display while listening to a DAB channel.

Each time the INFO/RDS MODE button is pressed, the information is displayed as follows.

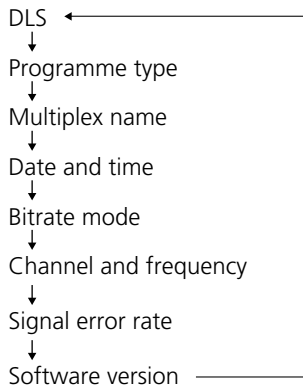
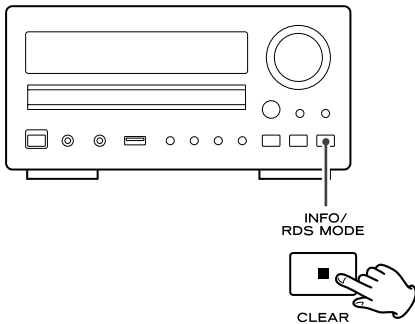

DLS

The Dynamic Label Segment (DLS) is the scrolling text label supplied by the radio station. It may be information on music titles or details regarding the programme or station.



Programme type

This is a description of the type of broadcast supplied by the radio station such as Pop, Rock or Classical music.



Multiplex name

This displays the name of the Multiplex that is broadcasting the programme.

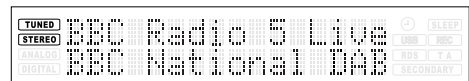

Date and time

This displays the current date and time, which is supplied by the radio station and should always be accurate.



- The clock setting will be automatically adjusted according to the clock time data. If you tune in a DAB station broadcasting incorrect clock time data, the clock might be wrongly adjusted, and that may eventually affect the timer operation.

No matter which DAB mode is selected, the unit receives clock time data and adjusts the clock.

Bitrate mode

This displays the bitrate of the current playing broadcast.

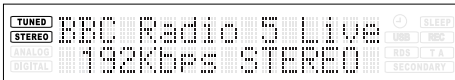

Channel and frequency

This displays the channel and frequency of the current playing broadcast.



Sig error rate (Signal error rate)

This displays the digital bit error rate (0-99) of the currently tuned channel. The lower the figure the better the quality of the received broadcast.

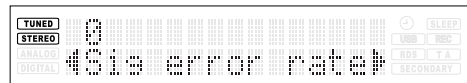

Sw version (Software version)

This displays the version number of the installed software.

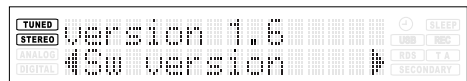

Listening to FM/AM

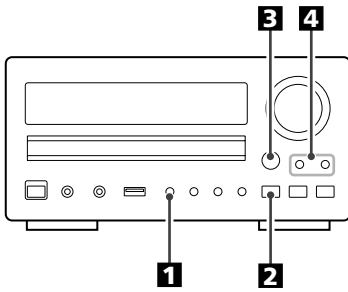

1 Press the **SOURCE** button repeatedly to select **TUNER** mode.



2 Press the **BAND** button to select **FM** or **AM**.

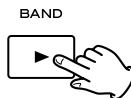

3 Press the **TUNING MODE** button to select 'Auto tune' mode.



Each time the **TUNING MODE** button is pressed, the mode is changed as follows.

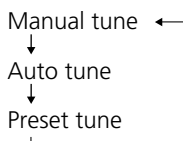

4 Select the station you want to listen to (auto selection).

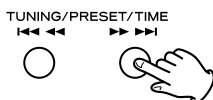

When a station is tuned in, the tuning process will stop automatically.

If you want to stop the tuning process, press the **TUNING/PRESET/TIME** button.

Selecting stations which cannot be tuned automatically (Manual tune)

Select 'Manual tune' in step **3**.

Repeatedly press the **TUNING/PRESET/TIME** button until the station you want to listen to is found. Or hold down the **TUNING/PRESET/TIME** button until the station you want to listen to is found and release the button.

FM: 50 kHz steps, AM: 9 kHz steps

- 'STEREO' is displayed when a stereo broadcast is tuned in.
- 'TUNED' is displayed when a broadcast is correctly tuned in.

FM MODE Button

Pressing this button alternates between Stereo mode and Mono mode.

Stereo

FM stereo broadcasts are received in stereo and the **STEREO** indicator lights in the display.

Mono

To compensate for weak FM stereo reception, select this mode. Reception will now be forced monaural, reducing unwanted noise.

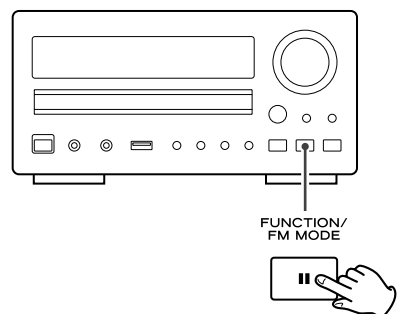

Preset Tuning 1

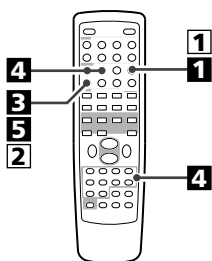

You can store up to 30 FM, 30 AM and 10 DAB stations.

Preset Manually (FM/AM/DAB)

- 1 Select DAB, AM or FM by pressing the **BAND** button.



- 2 Tune the station you would like to store.

- 3 Press the **MEMORY** button.



FM or AM

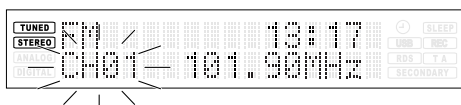

DAB

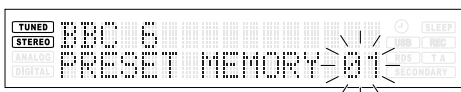

'CH01' or '01' blinks on the display.

- 4 Within 4 seconds, select the preset you would like to use for this station using the **PRESET** buttons.

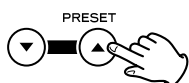

You can also use the numeric buttons.

- When you use the numeric buttons, press the input selector button of the remote control first.

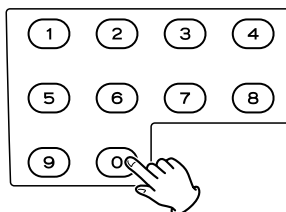

For instance, to select preset number 25, first press the TUNER button, and then press '2' and '5'.

To select numbers less than 10, press '0' and then the number. As an example, to select number 5, press '0' and '5'. (Optionally, you may press just the number '5' and then wait a few seconds.)

- 5 Within 4 seconds, press the **MEMORY** button.



- If you don't press the MEMORY button within 4 seconds after selecting the channel, the selection will be canceled.

To store more stations, repeat steps 1 to 5.

Preset Automatically (FM/AM only)

- 1 Select AM or FM by pressing the **BAND** button.



- 2 Press the **MEMORY** button for more than 3 seconds.



Up to 30 of the best received stations in your area will be stored automatically.

Preset Tuning 2

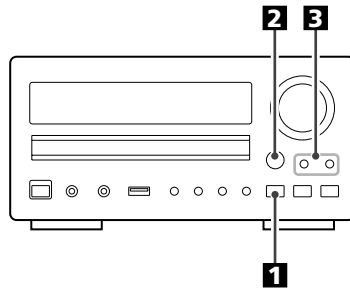

How to select DAB preset stations

See 'Preset tune' of page 28.

How to select FM/AM preset stations

1 Select AM or FM by pressing the BAND button.

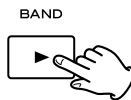

2 Select 'Preset tune' by pressing the TUNING MODE button.



3 Select a preset channel.

Press the TUNING/PRESET/TIME button repeatedly until the desired preset station is found.

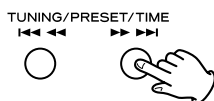

- Preset channels can also be selected by the PRESET (▼/▲) buttons or the numeric buttons of the remote control.
- When you use the numeric buttons, press the input selector button of the remote control first.
- When using the remote control, you can skip step **2**.

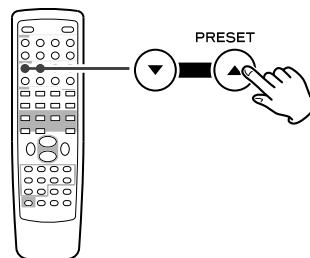
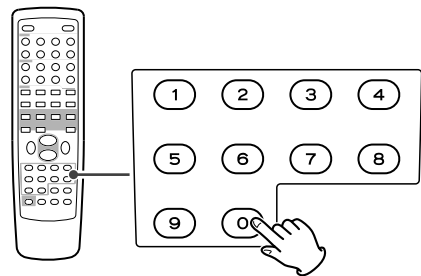

The Radio Data System (RDS) is a broadcasting service which allows stations to send additional information along with the regular radio programme signal.

RDS works on the FM waveband in Europe only.

1 Tune in an FM station (see steps 1 to 4 of page 32).

2 Press the INFO/RDS MODE button.

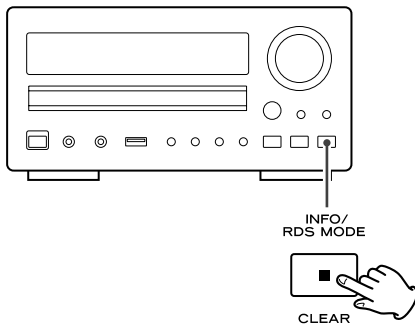

Each time the RDS MODE button is pressed briefly, the RDS mode is changed as follows:

Program service

When you select Program service, 'Program service' will blink for about 3 seconds and then the programme service name or a station's name will be displayed. If there is no programme service data, the frequency will be displayed.

RDS Clock time

Displays the information about times provided from the station.

When you select RDS Clock time, 'RDS Clock time' will blink for about 3 seconds and then the clock time will be displayed.

If there is no time data, 'NO CT' will be displayed.

RDS Program type

When you select RDS Program type, 'RDS Program type' will blink for about 3 seconds and then the programme type will be displayed.

RDS Radio text

When you select RDS Radio text, 'RDS Radio text' will blink for about 3 seconds and then the news of stations composed of up to 64 symbols will be displayed.

If there is no radio text data, RDS mode will be automatically switched to Program service mode.

Traffic announce

When you select Traffic announce, 'Traffic announce' will blink for 3 seconds and then the unit searches for a traffic announcement.

- When a traffic programme is found, the Traffic announce mode is switched to Program service mode.

If the station currently selected is transmitting a traffic program signal, the RDS mode will be switched to Program service mode without searching for a traffic program.

PTY Search

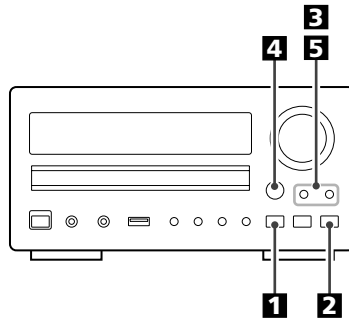

You can search for stations by programme type.

1 Select FM by pressing the BAND button.

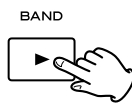

2 Press the INFO/RDS MODE button for more than 3 seconds.

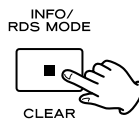

3 Select the desired PTY programme using the TUNING/PRESET/TIME buttons.



Select your desired one from among 31 kinds of PTY programmes. The programme type will blink.

4 Press the ENTER button.



The programme type stops blinking.

5 Press the TUNING/PRESET/TIME button.

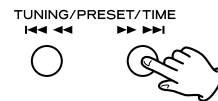

Search starts.

- When the programme that you have selected is found, searching stops and the programme type will be displayed.
- If the same programme type is not found during PTY Search, it will stop at the beginning frequency.
- If you want to stop searching, press the INFO/RDS MODE button.

About DAB

News: brief announcements, events, public opinion, reports, actual situations.

Current Affairs: a kind of suggestion including practical announcements other than news, documents, discussion, analysis and so on.

Information: daily information or reference such as weather forecast, consumer guide, medical assistance and so on.

Sport: sports related programs.

Education: educational and cultural information.

Drama: all kinds of radio concert and serial drama.

Cultures: all aspects of national or local culture including religious events, philosophy, social science, language, theatre, and so on.

Science: programs on natural science and technology

Varied Speech: popular programs such as quiz, entertainment, private interview, comedy, satire and so on.

Pop Music: program on commercial, practical and popular songs, and sale volume of discs, etc.

Rock Music: practical modern music generally composed and played by young musicians.

Easy Listening: popular music usually lasting for less than 5 minutes.

Light Classics M: classical music, instrumental music, chorus, and light music favored by non-professionals.

Serious Classics: orchestra including great operas, symphony, chamber music and so on.

Other Music: other music styles (Rhythm & Blues, Reggae, etc.)

Weather & Metr: weather reports, forecast

Finance: financial reports, commerce, trading

Children's Progs: children's programs

Social Affairs: social affairs

Religion: religious programs

Phone In: program in which the public expresses its view by phone.

Travel & Touring: travel reports

Leisure & Hobby: programs concerning recreational activities

Jazz Music: jazz music

Country Music: country music

National Music: national music

Oldies Music: music from the so-called golden of popular music

Folk Music: folk music

Documentary: documentaries

Alarm Test

Alarm-Alarm!: a program notifying an emergency or a natural disaster.

With this unit you can receive and listen to Digital Audio Broadcast (DAB) programmes. DAB uses digital, not analogue signals, resulting in near CD-quality audio with virtually interference-free reception. Along with superior quality audio, DAB can also deliver additional audio channels and text. In the future, computer data and images are also possible.

Digital radio is broadcast as groups of data called ensembles or multiplexes. Each multiplex can contain a number of stations (services) and each station contains a primary service and can contain secondary services as illustrated in the following diagram.

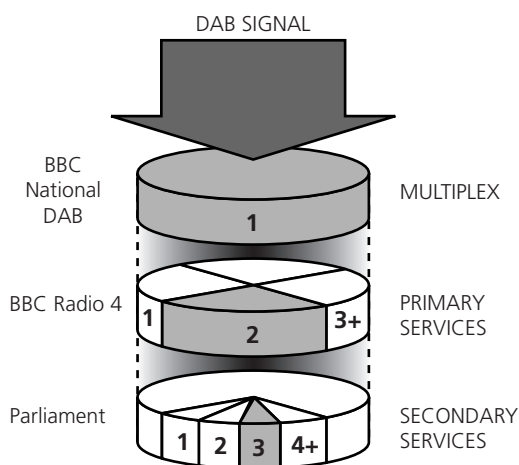

Each multiplex is transmitted in a set frequency range and received by this unit for decoding. You can receive multiplexes broadcast in the 174-240 MHz frequency band and store the services in each multiplex for you to access. The number of multiplexes you receive depend on your location. Channels used in the UK are in the range 10A to 12D.

Multiplexes and stations have labels (names) that are used to identify them. Instead of needing to know the particular frequency of your favourite broadcast, you can simply select the station name. Secondary services and additional data such as text or multiplex info are also available.

Setting the Clock

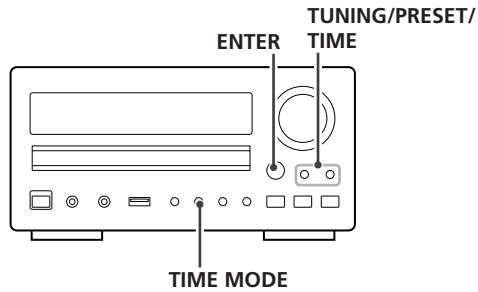

1 Press the TIME MODE button.



Every time the TIME MODE button is pressed, the mode is changed as follows.

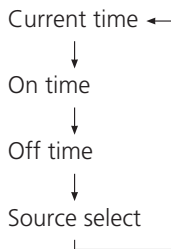

- The unit uses the 24-hour 'military' clock.
- When no action is taken for 1 minute, the time adjust mode will be cancelled.
- Press the STOP button to cancel the time setting.

2 Press the TUNING/PRESET/TIME buttons to set the current hour.

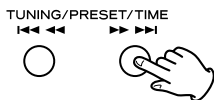

3 Press the ENTER button.



The 'minute' value blinks.

4 Press the TUNING/PRESET/TIME buttons to set the current minute.

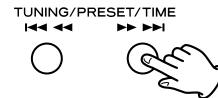

5 Press the ENTER button.



The clock starts from 00 seconds.

Setting the Timer

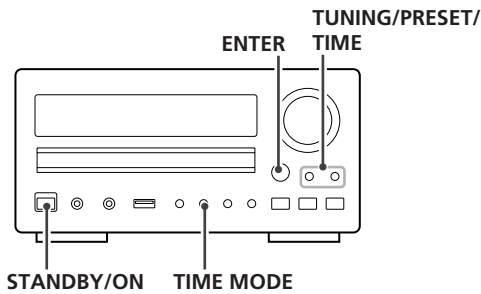

- Adjust the clock before setting the timer.
- When no action is taken for 1 minute, the timer setting mode will be cancelled.

1 Press the **TIME MODE** button repeatedly until 'On time' is displayed.



'On time' appears on the display, and the 'hour' value blinks.

2 Press the **TUNING/PRESET/TIME** buttons to set the hour value, and press the **ENTER** button.

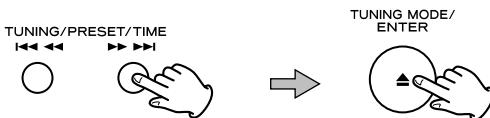

The 'minute' value blinks.

3 Press the **TUNING/PRESET/TIME** buttons to set the minute value, and press the **ENTER** button.

'Off time' appears on the display, and the 'hour' value blinks.

4 Repeat step **2** and **3** to set the Off time.

'Source select' appears on the display.

5 Press the **TUNING/PRESET/TIME** buttons to select the source, and press the **ENTER** button.

Now the timer setting is stored in memory.

6 Press the **TIMER** button on the remote control.

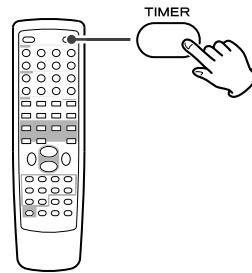

The timer indicator '⊕' lights on the display.

7 Prepare for timer operation.

Timer Playback

Adjust the volume, tune in a station, set CD, etc.

Timer Recording

You are able to set the various external USB storage devices such as USB flash memory to record program at the desired time.

Connect the external USB storage device to the unit beforehand.

Press the TIMER button on the remote control once more.

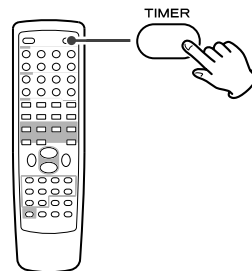

The REC indicator lights on the display.

One minute before the set time the unit turns on and recording begins at the set time.

- When you don't use timer, press the **TIMER** button repeatedly to turn it off until the timer indicator '⊕' disappears from the display. Press the **TIMER** button again to turn it on.

8 Press the **STANDBY/ON** button to turn the unit standby.



The standby indicator surrounding the **STANDBY/ON** button blinks at interval of 4 seconds.

Sleep Timer

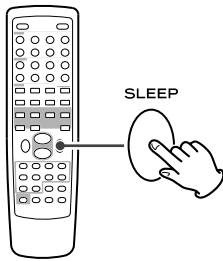

The power can be switched off after a specified amount of time.

Press the SLEEP button repeatedly until desired time appears on the display.

SLEEP-90 (80, 70 ... 10)

The power will be switched off 90 (80, 70 ... 10) minutes later.

(normal display)

The sleep timer is off.

- The display is dimmed when you set the sleep timer.
- If you want to check the remaining time, press the SLEEP button once. The remaining time will be displayed for 3 seconds, and return to the normal display.

Listening to the External Sources

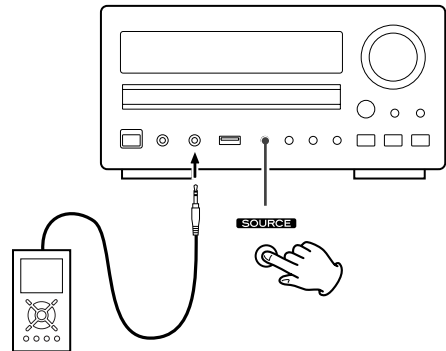

You can listen to the external source such as VCR deck, MP3 player, TV or tape recorder connecting the AUX or TAPE input jack.

Press the SOURCE button repeatedly to select AUX 1, AUX 2, AUX 3 or TAPE.

When using the PHONES jack of your mini player, you must adjust the volume of the mini-player or you may hear no sound from your CR-H255.

Specifications

AMPLIFIER Section

Output Power25 W/ch (6 ohms, 0.5 %, 1 kHz)
Input Sensitivity 400 mV/47 kohms
Frequency Response
20 Hz to 60,000 Hz (+1/-3 dB)

TUNER Section

FM Section

Tuning Range 87.50 MHz to 108.00 MHz
(50 kHz steps)
Signal-to-Noise Ratio 65 dB (Mono)
60 dB (Stereo)
Presets 30

AM Section

Tuning Range 522 kHz to 1629 kHz
(9 kHz steps)
Signal-to-Noise Ratio 35 dB
Presets 30

DAB Section

Tuning range Band 3, 174 MHz-240 MHz
Input 50 ohms, nominal
Max signal -3 dBm typ
Sensitivity -96 dBm typ
Adjacent Channel Rejection 35 dB typ

Presets 10
Audio output Stereo, 2.5 V P-P
Digital output 24 bit/48 kHz resolution

CD PLAYER Section

Frequency Response . . . 20 Hz to 20,000 Hz (± 2 dB)
Signal-to-Noise Ratio more than 95 dB
Wow and Flutter Unmeasurable

USB Section

Playback

Frequency Response . . . 20 Hz to 20,000 Hz (± 2 dB)
Signal-to-Noise Ratio more than 85 dB

Recording

Frequency Response . . . 20 Hz to 15,000 Hz (± 2 dB)
Signal-to-Noise Ratio more than 85 dB

GENERAL

Power Requirements 230 V AC, 50 Hz
Power Consumption 75 W
(standby) 1.5 W

Dimension (W x H x D) 215 x 110 x 359 mm
Weight 4.4 kg

Standard Accessories

Remote Control Unit (RC-1038) x 1
Batteries (AAA) x 2
AM Loop Antenna x 1
FM Lead-type Antenna x 1
DAB Antenna x 1
Owner's Manual x 1
Warranty Card x 1

- Design and specifications are subject to change without notice.
- Weight and dimensions are approximate.
- Illustrations may differ slightly from production models.

Troubleshooting

In case of trouble with the unit, please take the time to look through this chart and see if you can solve the problem yourself before you call your dealer or TEAC service center.

Amplifier

No power

- Check the connection to the AC power supply.

No sound from speakers.

- Check the connection to the speakers.
- Adjust the volume.
- Select proper source.
- Pull out the headphone plug from PHONES jack.
- If muting is on, press the MUTING button.

The sound is noisy.

- The unit is too close to a TV set or similar appliances. Install the unit apart from them, or turn them off.

Remote Control Unit

Remote control doesn't work.

- If the batteries are exhausted, change the batteries.
- Use remote control unit within the range (5m) and point at the front panel.
- Clear obstacles between the remote control unit and the main unit.
- If a fluorescent light is near the unit, turn it off.

Tuner (FM/AM)

Cannot listen to any station, or signal is too weak.

- Tune in the station properly.
- If a TV is near the unit, turn it off.
- Install the antenna again after locating the best reception position.
- An external antenna is recommended.

Though the broadcast is stereo, it sounds monaural.

- Press the FM MODE button.

DAB tuner

No sound.

- Ensure that the CR-H255 has been able to locate DAB stations.

'NO stations Available' appears on the display.

- Check that antenna is connected (see page 9).
- Ensure that DAB coverage exists in your area.

Cannot access secondary services.

- At the time of publishing not many secondary services are available, this will increase as more DAB stations start broadcasting. If a secondary service station is available, the secondary indicator >> will be displayed next to the station name.

Display goes out or displayed 'service off air'.

- This may occur if a broadcaster changes the label of a service or removes a label whilst you are listening to it. The CR-H255 will try to retune to this station, or alternatively follow the procedure for auto tune on page 25.

Cannot listen to the selected station.

- Ensure you have pressed the ENTER button when you want to listen to your selection. The station you are currently listening to will be displayed on the first line of the display, as you scroll through the station order list the second line will show other station options. Press the ENTER button to activate your selection.

A burbling sound is heard on some stations.

- DAB like other digital media is good at producing quality audio from a low level signal, however if this signal level is too low a 'burbling' sound can sometimes be heard. To reduce this, try repositioning your antenna to gain maximum signal strength.

CD Player

Cannot play.

- ➔ Load a disc with label side up.
- ➔ If the disc is dirty, clean the surface of the disc.
- ➔ A blank disc has been loaded. Load a prerecorded disc.
- ➔ Unfinalized CD-R/CD-RW disc is not playable. Finalize the disc properly.

Sound skips.

- ➔ Place the unit on a stable place to avoid vibration and shock.
- ➔ If the disc is dirty, clean the surface of the disc.
- ➔ Don't use scratched, damaged or warped discs.

No program playback.

- ➔ In the stop mode press PROGRAM button to enter the program mode, and press the PLAY button (▶) to start playing.

MP3/WMA

There is no sound even if the PLAY button (▶) is pressed.

- ➔ Check if there are MP3 or WMA files on the USB.
- ➔ Non-playable file formats (e.g MPEG 1 LAYER 2 file) cannot be played.

'No song title No artist No album' appears on the display.

- ➔ There is no ID3 tag information for the music file. Edit the song title, artist, and album information of the song on a PC using the MP3 or WMA making application.

Some unknown characters are displayed on the display panel.

- ➔ This unit cannot display symbols and full-size or double-byte characters (such as Japanese, Chinese, etc.) correctly. File name of MP3 or WMA should be alphanumeric characters.

If normal operation cannot be recovered, unplug the power cord from the outlet and plug it again.

Maintenance

If the surface of the unit gets dirty, wipe with a soft cloth or use diluted neutral cleaning liquid. Be sure to remove any fluid completely. Do not use thinner, benzine or alcohol as they may damage the surface of the unit.

Beware of condensation

When the unit (or a disc) is moved from a cold to a warm place, or used after a sudden temperature change, there is a danger of condensation; vapor in the air could condense on the internal mechanism, making correct operation impossible. To prevent this, or if this occurs, leave the unit for one or two hours with the power turned on. The unit will stabilize at the temperature of its surroundings.

TEAC

TEAC CORPORATION	3-7-3, Nakacho, Musashino-shi, Tokyo 180-8550, Japan Phone: (0422) 52-5081
TEAC AMERICA, INC.	7733 Telegraph Road, Montebello, California 90640 Phone: (323) 726-0303
TEAC CANADA LTD.	5939 Wallace Street, Mississauga, Ontario L4Z 1Z8, Canada Phone: (905) 890-8008
TEAC MEXICO, S.A. De C.V	Campesinos N°184, Colonia Granjas Esmeralda, Delegacion Iztapalapa, CP 09810, México DF Phone: (525) 581-5500
TEAC UK LIMITED	Unit 19 & 20, The Courtyards, Hatters Lane, Watford, Hertfordshire, WD18 8TE , U.K. Phone: (0845) 130-2511
TEAC EUROPE GmbH	Bahnstrasse 12, 65205 Wiesbaden-Erbenheim, Germany Phone: 0611-71580
TEAC ITALIANA S.p.A.	Via C. Cantù 9/A, 20092 Cinisello Balsamo, Milano, Italy Phone: 02-66010500
TEAC AUSTRALIA PTY., LTD.	280 William Street, Melbourne VIC 3000, Australia Phone: (03) 9672-2400 A.B.N. 80 005 408 462

This appliance has a serial number located on the rear panel. Please record the model number and serial number and retain them for your records.

Model number

Serial number

0905-MA-1008A

Free Manuals Download Website

<http://myh66.com>

<http://usermanuals.us>

<http://www.somanuals.com>

<http://www.4manuals.cc>

<http://www.manual-lib.com>

<http://www.404manual.com>

<http://www.luxmanual.com>

<http://aubethermostatmanual.com>

Golf course search by state

<http://golfingnear.com>

Email search by domain

<http://emailbydomain.com>

Auto manuals search

<http://auto.somanuals.com>

TV manuals search

<http://tv.somanuals.com>