



# SDU50 and SDU90 Shortening Disposal Units

Project \_\_\_\_\_  
 Item \_\_\_\_\_  
 Quantity \_\_\_\_\_  
 CSI Section 11400 \_\_\_\_\_  
 Approval \_\_\_\_\_  
 Date \_\_\_\_\_

Shortening Disposal Units

## Models

PSDU50

PSDU90



### Standard Features

- 9.6" (244 mm) drain height (with cover open) allows unit to fit under most fryers to permit direct draining of fryers into unit
- Heavy-duty manual pump can empty 50 lbs. (25 liters) of oil in less than 60 seconds
- Large 7" (178 mm) wheels provide easy transporting of oil, even across parking lots; and no lifting is necessary
- One-year warranty

### Options & Accessories

- 24" hose
- 48" hose

## Specifications

### ***Specifically designed for the removal of waste oil from the kitchen***

Dean provides the answer for the transportation of waste oil from the kitchen to the disposal container, with shortening disposal units, available in 50- and 90-lb. (25 and 45 liter) capacities.

The low center of gravity provides stability when transporting or operating the unit. The heavy-duty manual pump is located at a convenient height; so there is no stooping or bending required. Also, there is no lifting required to operate the unit.

5489 Campus Drive  
Shreveport, LA 71129 USA

Tel: 318-865-1711  
Tel: 1-800-221-4583  
Fax: 318-868-5987  
E-mail: [info@dean.enodis.com](mailto:info@dean.enodis.com)

<http://dean.enodis.com>  
Bulletin No. 830-0044 11/07  
Litho in U.S.A. ©Frymaster, LLC

Enodis®

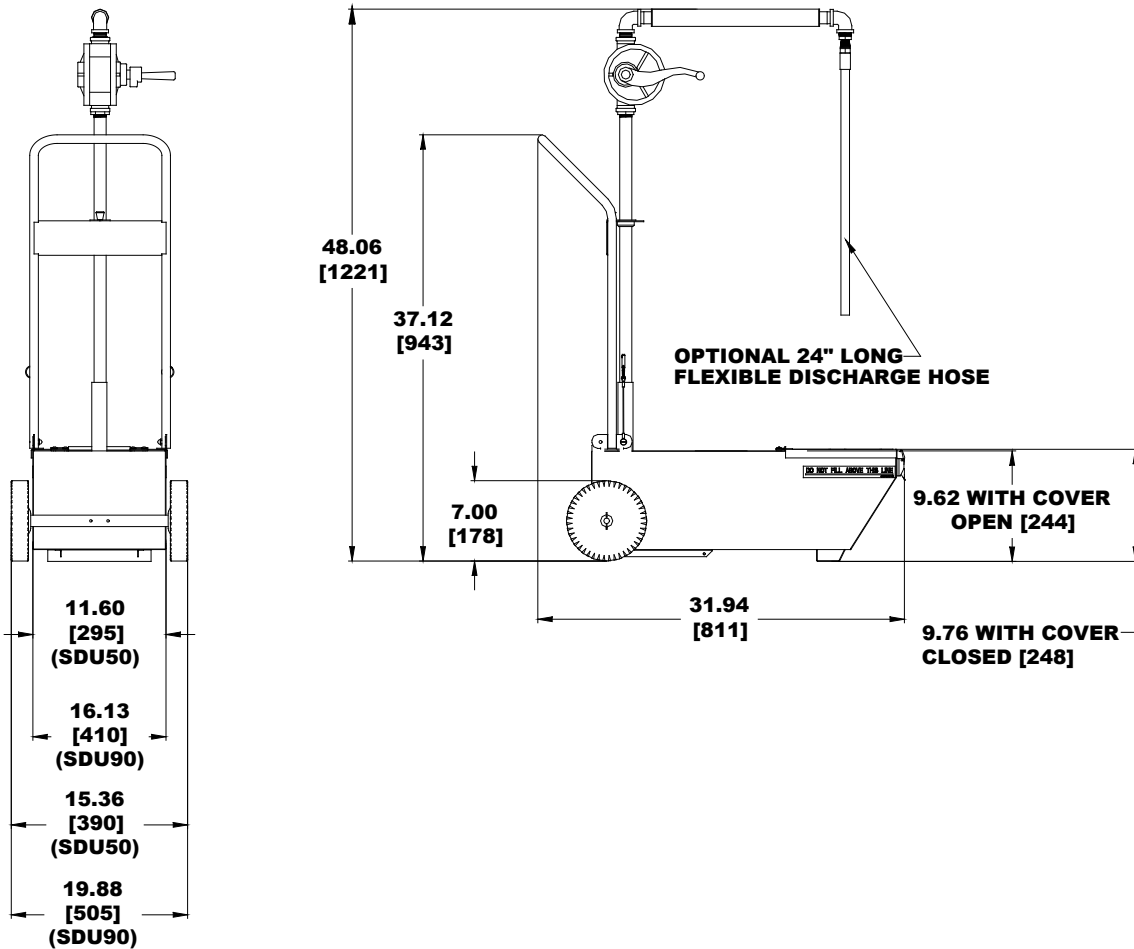

**DIMENSIONS**

MODEL NO.	SHORTENING CAPACITY	ASSEMBLED SIZE (mm)			DRAIN HEIGHT (mm)	NET WEIGHT	SHIPPING INFORMATION			SHIPPING DIMENSIONS		
		HEIGHT	WIDTH	LENGTH			WEIGHT	CLASS	CUBE	HEIGHT	WIDTH	LENGTH
PSDU50	50 lbs. (25 liters)	48.06" (1221)	15.36" (390) Overall 11.60" (295) Tank Only	31.94" (811)	9.62" (244) w/door open	45 lbs. (20 kg)	62 lbs. (28 kg)	85	7	20" (508)	21" (533)	30" (762)
PSDU90	90 lbs. (45 liters)	48.06" (1221)	19.88" (505) Overall 16.13" (410) Tank Only	31.94" (811)	9.62" (244) w/door open	49 lbs. (22 kg)	67 lbs. (30 kg)	85	10	20" (508)	23" (584)	39" (991)

**SHORT TERM SPECIFICATION**

Shall be DEAN shortening disposal unit, Model # \_\_\_\_\_  
 \_\_\_\_\_, only \_\_\_\_\_" wide x \_\_\_\_\_" deep with \_\_\_\_\_ oil  
 capacity

**ORDERING DATA**

Please specify:  
 SDU50 -- 50 lb. (28 L) capacity  
 SDU90 -- 90 lb. (50 L) capacity

## Free Manuals Download Website

<http://myh66.com>

<http://usermanuals.us>

<http://www.somanuals.com>

<http://www.4manuals.cc>

<http://www.manual-lib.com>

<http://www.404manual.com>

<http://www.luxmanual.com>

<http://aubethermostatmanual.com>

Golf course search by state

<http://golfingnear.com>

Email search by domain

<http://emailbydomain.com>

Auto manuals search

<http://auto.somanuals.com>

TV manuals search

<http://tv.somanuals.com>