

Safety Information

CAUTION!

Invisible laser radiation when open. Avoid exposure to beam. Class 1 laser product. This system must be opened only by qualified technicians to prevent accidents caused by the laser beam.

LASER $\lambda = 780 \text{ nm}$, P max = 5 mW

Rating Information: At bottom of the unit this unit comply with the existing requirements



In accordance with the rating plate of the unit, this unit complies with current standards concerning electrical safety and electromagnetic compatibility.



Please respect the environment. Before throwing any batteries away, consult your distributor who may be able to take them back for specific recycling.



EN

CAUTION – INVISIBLE LASER RADIATION WHEN OPEN AND INTERLOCKS FAILED OR DEFEATED. AVOID EXPOSURE TO BEAM.

ATTENTION – RAYONNEMENT LASER INVISIBLE DANGEREUX EN CAS D'OUVERTURE ET LORSQUE LA SECURITE EST NEUTRALISEE. EXPOSITION DANGEREUSE AU FAISCEAU.

ADVARSELI!

USYNLIG LASERSTRÅLING, NÅR ENHEDEN ER ÅBEN OG SIKKERHEDSÅFBRYDERNE ER UDE AF FUNKTION ELLER OMGÅET. UNDGÅ EKSPONERING FOR STRÅLEN.

VORSICHT!

UNSICHTBARE LASERSTRAHLUNG BEI GEÖFFNETER ABDECKUNG, FÄLLES SICHERHEITS-VERRIEGELUNG NICHT EINGERASTET IST ODER WENN SIE BEEINTRÄCHTIGT IST. SETZEN SIE SICH NICHT DEM LASERSTRAHL AUS!



CLASS I LASER PRODUCT
LASER KLASSE I
LASERAPPARAT AV KLASSE I
AREIL A LASER DE CLASSE I
LUOKAN I LASERLAITE
LASERPRODUKT AF KLASSE I

VARNING!

OSYNLIG LASERSTRÅLNING NÅR DENNA DEL ÄR ÖPPNAD OCH SPÄRRARNA ÄR URKOPPLADE. TITTA EJ IN I STRÅLEN.

VARO

AVATTAESSA JA OHITETTAESSA SUOJALUKITUS OLET ALTIINA NÄKYMÄTTÖMÄLLE LASERSÄTEILYLLE. ÄLÄ KATSO SÄTEESEEN.

	CAUTION RISK OF ELECTRIC SHOCK DO NOT OPEN	
THE LIGHTNING FLASH AND ARROWHEAD WITHIN THE TRIANGLE IS A WARNING SIGN ALERTING YOU OF "DANGEROUS VOLTAGE" INSIDE THE PRODUCT.	CAUTION: TO REDUCE THE RISK OF ELECTRIC SHOCK, DO NOT REMOVE COVER (OR BACK). NO USER-SERVICEABLE PARTS INSIDE. REFER SERVICING TO QUALIFIED SERVICE PERSONNEL.	THE EXCLAMATION POINT WITHIN THE TRIANGLE IS A WARNING SIGN ALERTING YOU OF IMPORTANT INSTRUCTIONS ACCOMPANYING THE PRODUCT.
SEE MARKING ON BOTTOM / BACK OF PRODUCT		

WARNING: TO PREVENT FIRE OR ELECTRICAL SHOCK HAZARD, DO NOT EXPOSE THIS PRODUCT TO RAIN OR MOISTURE.

Contents

EN

Safety information	CD player	4
Before you begin	Tape player	5
General controls	Troubleshooting tips	6
Display	Maintenance	7
Radio	More Information	8

Before you begin

Useful Advice

Do not use your system immediately after transporting it from a cold place to a warm place, as condensation may cause the system to malfunction. If moisture forms inside this system, it may not operate properly. To correct the problem, turn off the power and wait about 30 minutes for moisture to evaporate.

This system is fitted with a laser. To avoid accidents, it is to be opened by qualified technicians only.

Never leave the tray open as dust could cover the laser lens and/or the tray could be bumped into accidentally.

Do not place the system near wet areas such as bathrooms and pool side. Avoid storing the system at humid places or near abnormally heated areas.

Power is continuously supplied to the system. To disconnect power completely, unplug the power cord from the power outlet.

Ensure minimum distance around the apparatus for sufficient ventilation. The ventilation should not be impeded by covering the ventilation openings with items, such as newspaper, etc.

No naked flame source, such as lighted candles, should be placed on the apparatus.

Attention should be paid to environment aspects of battery disposal.

The apparatus shall not be exposed to dripping or splashing and that no objects filled with liquids, such as vases, shall be placed on the apparatus.

Battery Power

You can insert 6 D-sized alkaline batteries (not supplied) and you can take your stereo just about anywhere. Open the battery compartment door on the back of the unit by pressing down on the arrow and pulling out the cover. Insert batteries in the battery compartment. (See diagram)

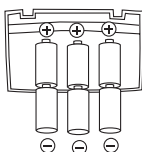

Note that the AC line cord must be unplugged from the jack on the back of the unit to operate on batteries.



Important:

Be sure to remove batteries when storing the set for more than 30 days. Leaky batteries can badly damage the system. Always return tape operation buttons to their off position before storing. This will relieve pressure on certain parts in the tape recorder that might deform after long periods of time. Be sure to dispose of leaky, weak or dead batteries properly according to federal, state, and local regulations. To prevent injury or damage, do not reverse batteries and do not mix battery type.

General controls

EN

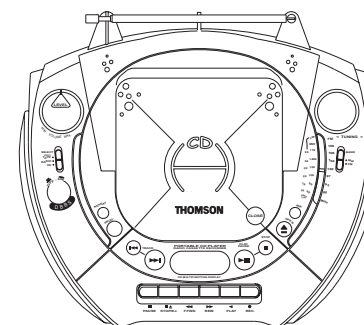

MIN. VOLUME MAX. — increases or decreases output volume

SELECT – selects among TAPE (OFF), RADIO and CD mode

DBBS – turns on/ off digital bass boost system

REPEAT – repeats one track or entire disc playback

PROG. – enters program mode for CD playing

TRACK |◀◀▶▶| – searches / skips CD track forward or backward

PLAY PAUSE – starts or pauses CD play

STOP – stops CD playback

OPEN ▲ – opens the CD compartment door

MIX – plays CD tracks randomly

CLOSE – push to close the disc compartment door

BAND – selects between MW/FM band

< TUNING > – rotate to search for radio stations

Cassette Player

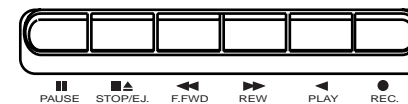

PAUSE – pauses tape playback or recording

STOP/ EJ. – stops tape playback, winding or recording, opens cassette door

F. FWD/ REW – winds tape forward or backward

PLAY – starts tape playback

REC – starts tape recording

Display

EN

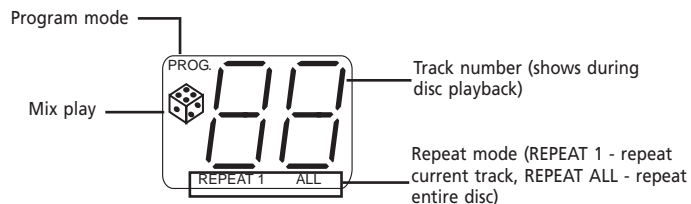

Radio

Tuning to a station

1. Select **RADIO** from the **SELECT** switch.
2. Slide **BAND** to select between MW/FM band.
3. Rotate **< TUNING >** to select radio station.



4. Adjust **MIN. VOLUME MAX.** to your desired listening level.



Tip:
Extend or reposition the antenna for better FM reception. Move the unit for better MW receptions

CD player

Playing disc

This unit is compatible with audio CD-R discs.



1. Selects **CD** from the **SELECT** switch.
2. Press **OPEN** to open disc compartment door.
3. Insert a disc with label face up.
4. Push **CLOSE** to close disc compartment door. Total number of track on disc can be read from display.
5. Press **PLAY/PAUSE** to begin CD playback.
6. Press or to skip to previous or next track respectively.
7. Press and hold or to search quickly current track backward or forward respectively.
8. Adjust **MIN. VOLUME MAX.** to your desired listening level.
9. Press **PLAY/PAUSE** or **STOP** to pause or stop disc playback respectively. To resume playback, press **PLAY/PAUSE** again.

Repeating

Press **REPEAT** once to repeat current track and REPEAT 1 icon shows on display.

Press **REPEAT** twice to repeat entire disc and REPEAT ALL icon shows on display.

Press **REPEAT** a third time to turn off repeat mode.



Note:
When random playback is activated, only Repeat All can be selected.

Random Playback

During playback, press to play tracks randomly.

In stop mode, press to activate random function and press **PLAY/PAUSE** to begin random playback.

The icon appears on display when random playback is activated.

Press again for de-selection.

Programming

1. Press **PROG.** to enter program mode. The program location will flash once on the display. Then the track number stored in the memory location will keep flashing. If the memory location is empty, 00 will be flashing.
2. Press or to select the track you want to program.
3. Press **PROG.** again to confirm your selection and access the next program location.
4. Repeat steps 2 to 3 to program to a maximum of 20 tracks.
5. Press **PLAY/PAUSE** in program mode to start program playback (**PROG.** indicator remains lit on the display). Press **STOP** to return to normal playback mode.



Tip:
If you are in normal playback mode but want to play the saved program. Press **PROG.** and then **PLAY.**

Clearing program list

Your program will be erased once you open the disc compartment door or change to another source mode (e.g. radio, tape).



Tape player

EN

Playing a tape

1. Select **TAPE** from the **SELECT** switch.
2. Press **STOP/EJ.** to open the tape deck door.
3. Insert a tape into the door and push the door closed.
4. Press **REW** or **F.FWD.** to wind the tape to the desired starting position. Press **STOP/EJ.** to stop winding.
5. Press **PLAY** to start playback, **PAUSE** to pause playback (release the button to resume playback) and **STOP/EJ.** to stop playback.



Recording to tape

From radio

1. Insert a tape into the deck.
2. Select **RADIO** from the **SELECT** selector.
3. Slide **BAND** to access the desired radio band.



Tip:

For better recording quality, use normal bias tape (Type I) only.

4. Tune to the station to be recorded.
5. Press **REC** and **PLAY** together to begin recording.
6. Press **PAUSE** or **STOP** to pause or stop recording respectively.

From CD

1. Insert a tape into the deck.
2. Select **CD** from the **SELECT** switch.
3. Insert the disc to be recorded.
4. Select the track or program to be recorded.
5. Press **REC** and **PLAY** together to begin recording.
6. Play the track or program to be recorded.
7. Press **PAUSE** or **STOP** to pause or stop recording respectively.

Troubleshooting tips

EN

Problem	Solution
System doesn't turn on	<ul style="list-style-type: none"> • Unplug the unit for a moment, and then plug it back in. • Check the outlet by plugging in another device
No sound	<ul style="list-style-type: none"> • Adjust volume setting. • Make sure you've selected the correct function
Poor radio reception	<ul style="list-style-type: none"> • Adjust the antenna for better reception • Try turning off electrical appliances near the unit, such as hair dryers, vacuum cleaners, or fluorescent lights
CD doesn't play	<ul style="list-style-type: none"> • Make sure you've put a CD in the tray • Make sure the CD's label is facing up • Try another CD • Make sure that Pause mode is not activated • Make sure CD function is selected
CD sound skips	<ul style="list-style-type: none"> • Clean the CD (as explained in "Maintenance") • Check CD for warping, scratches, or other damage • Check for vibration or shock that may affect the unit; move the set if necessary.

ESD Remarks:

In case of malfunction due to electrostatic discharge, just reset the unit (reconnecting the power supply may be required) to resume normal operation.

Maintenance

EN

Cleaning the exterior

- Disconnect the system from AC power before cleaning the exterior of the unit with a soft dust cloth
- Clean the exterior with a soft clean cloth or slightly moistened chamois leather. DO NOT use solvents as it may cause damage to the unit.

Handling CDs

- Do not touch the signal surfaces. Hold CDs by the edges, or by one edge and the hole.
- Do not affix labels or adhesive tapes to the label surfaces. Do not scratch or damage the label.
- CDs rotate at high speeds inside the player. Do not use damaged (cracked or warped) CDs
- Make sure CDs are stored in their original case after use. Keep them away from damp, humid or abnormally heated places.

Cleaning CDs

- Dirty CDs can cause poor sound quality. Always keep CDs clean by wiping them gently with a soft cloth from the inner edge toward the outer perimeter.
- If a CD becomes dirty, wet a soft cloth in water, wring it out well, wipe the dirt away gently, and then remove any water drops with a dry cloth.
- Do not use record cleaning sprays or antistatic agents on CDs. Also, never clean CDs with benzene, thinner, or other volatile solvents which may cause damage to disc surface.

CD Lens Care

- When your CD lens gets dirty it can also cause the system to output poor sound quality. To clean the lens you will need to purchase a CD lens cleaner which can maintain the output sound quality of your system. For instructions on cleaning the CD lens, refer to the ones accompanying the lens cleaner.

7

Notes on CD-R/ CD-RW Disc

- CD-R discs that are recorded using personal computers or other CD-R recorders may not be played on this unit due to the difference in recording platforms.
- Do not affix any type of labels to either side (recordable or labeled side) of a CD-R disc as this may result in the disc malfunctioning.
- To avoid damages to the CD-R disc, do not open the disc compartment door while the disc is being read. This may take more than 30 seconds.
- Do not load an unrecorded CD-R disc into the unit.

Cassettes

- To protect your recordings from accidental erasure on one or both sides of your cassette, snap out the tab at the top of the cassette. If you decide later to record on the tape, seal the hole with a piece of adhesive tape. (Refer to diagram on the right)

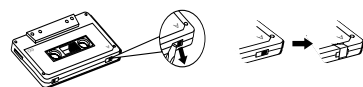

- **Quit Slacking** - A little bit of slack in your tapes can cause scratches on the tape, or worse yet, the tape could break. If you notice some slack in the tape, use a pencil to tighten it up before you insert it.

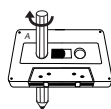

More information

Safety Precautions

- Never open the cabinet under any circumstances. Any repairs or internal adjustments should be made only by a trained technician.
- Never operate this product with the cabinet removed.
- Do not use your System immediately after transporting it from a cold place to a warm place, as condensation may cause the system to malfunction.
- Keep your unit away from humid areas and abnormally hot places.
- Do not touch the player with wet hands. If any liquid enters the player cabinet, take the player to a trained technician for inspection.
- This compact disc player uses a laser to read the music on the disc. The laser mechanism corresponds to the cartridge and stylus of a record player. Although this product incorporates a laser pick-up lens, it is completely safe when operated according to directions.
- Discs rotate at high speed inside the player. Do not use damaged, warped, or cracked discs.
- Do not touch the pick-up lens which is located inside the disc compartment. To keep dust from collecting on the pick-up lens, do not leave the compartment door open for an extended period of time. If the lens becomes dirty, clean it with a soft brush, or use an air blower brush designed for camera lenses.
- The apparatus shall not be exposed to dripping and splashing.

Important Battery Information

- Remove the batteries to avoid leakage if you do not use your system for more than one month.
- Discard leaky batteries immediately as leaking batteries may cause skin burns or other personal injuries. Dispose of batteries in the proper manner, according to provincial and local regulations.
- Any battery may leak electrolyte under the following circumstances:
 - if mixed with a different battery type,
 - if inserted incorrectly,

- if all batteries are not replaced at the same time,
- if disposed of in fire, or
- if an attempt is made to charge a battery not intended to be recharged

EN

Don't Infringe

This product should only be used for the purposes for which it is sold, that is, entertainment, violating no copyright law. Any attempts to use this product for which it is not intended is unlawful and therefore not condoned by Thomson.



Your THOMSON product is designed and manufactured with high quality materials and components which can be recycled and reused.

This symbol means that electrical and electronic equipment, at their end-of-life, should be disposed of separately from your household waste. Please, dispose of this equipment at your local community waste collection/recycling centre. In the European Union there are separate collection systems for used electrical and electronic product. Please, help us to conserve the environment we live in!

Technical Specification

Power supply: 230V~50Hz
Dimensions (H x W x D mm):
Unit size - TM9237: 180 x 305 x275
Tape deck: Response curve: 125Hz-8kHz (-5dB)
CD player: Response curve (+/- 2dB): 60Hz to 20 kHz
Rating Plate: Look for it at the bottom of the set.

8

Free Manuals Download Website

<http://myh66.com>

<http://usermanuals.us>

<http://www.somanuals.com>

<http://www.4manuals.cc>

<http://www.manual-lib.com>

<http://www.404manual.com>

<http://www.luxmanual.com>

<http://aubethermostatmanual.com>

Golf course search by state

<http://golfingnear.com>

Email search by domain

<http://emailbydomain.com>

Auto manuals search

<http://auto.somanuals.com>

TV manuals search

<http://tv.somanuals.com>