

Technics

Mini Changer System

SC-CH717

Operating Instructions
Instrucciones de funcionamiento

使用説明書

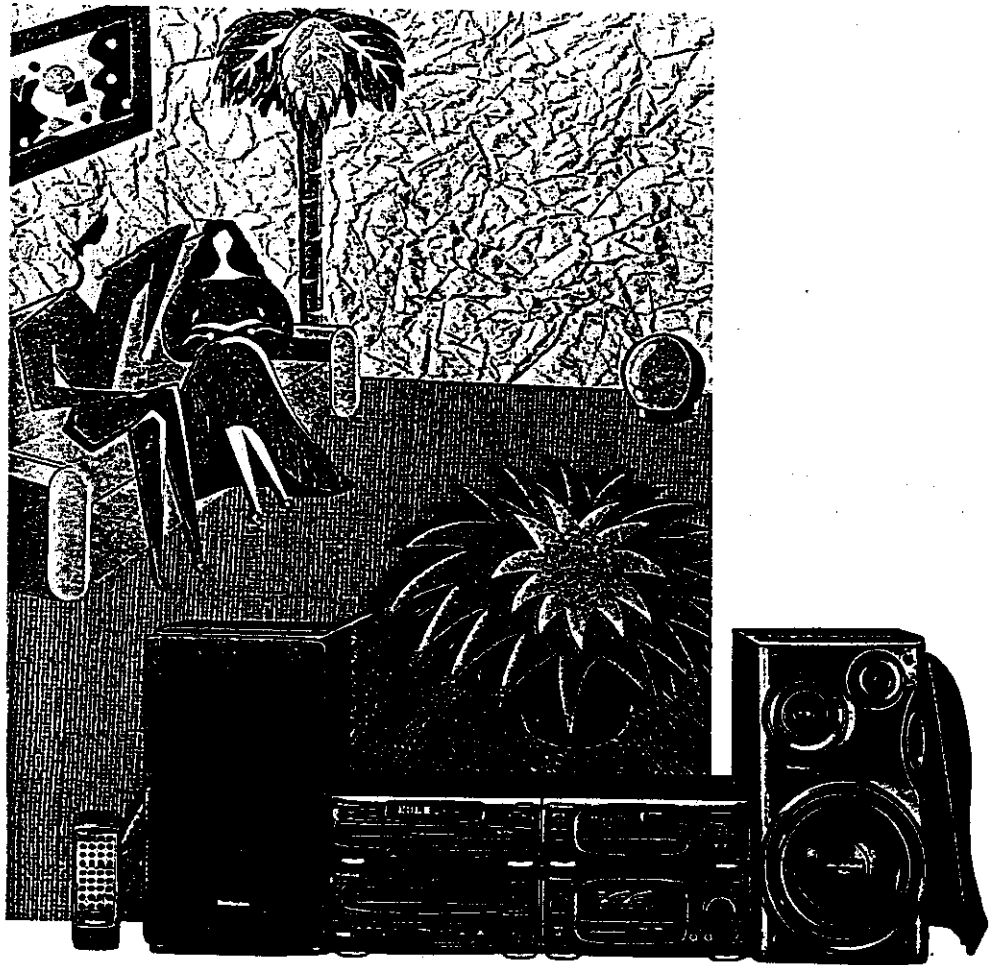

Before connecting, operating or adjusting this product, please read these instructions completely.

GC GN

COMPACT
disc
DIGITAL AUDIO
GRAPHICS

RQT2198-G

Dear customer

Thank you for purchasing this product.
For optimum performance and safety,
please read these instructions carefully.

These operating instructions are applicable
to the following systems.

System	SC-CH717
Amplifier	SE-CH717
Tuner/sound processor	ST-CH707
Compact disc changer	SL-CH515
Cassette deck	RS-CH505
Speakers	SB-CH717

According to the area, the tuner/sound processor is ST-CH505.

Table of contents

Suggestions for safety	5
Before use	5
Supplied accessories	8
Location of controls	10
Installation	16
Connections	18
Concerning the multi-control section	28
Concerning the remote control	32
Setting the time	34
Memory presetting	36
Listening to radio broadcasts	42
Listening to compact discs	46
Listening to tapes	64
Convenient functions	76
Making a recording from radio broadcasts	80
Recording from compact discs	88
Tape-to-tape recording	108
Changing the tone	114
Using the timer	126
Enjoying the microphone mixing	146
Changing the display	152
Using an external unit	154
Quick reference of remote control operations	158
Concerning compact discs	162
Maintenance	164
Concerning cassette tapes	166
Troubleshooting guide	168
Technical specifications	174

**CLASS 1
LASER PRODUCT**

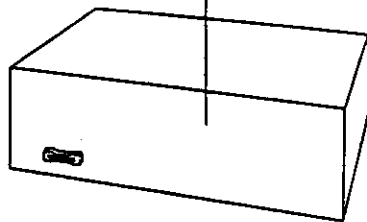

(Back of product)
(Komponentens bagside)
(產品背面)

Compact disc changer
Cambiador de discos compactos
激光換片器

小型換片器系統
松下電器產業製造日本大阪
製造在日本

**DANGER-Invisible
laser radiation when
open.
AVOID DIRECT EX-
POSURE TO BEAM.**

(Inside of product)

CAUTION!

THIS PRODUCT UTILIZES A LASER.
USE OF CONTROLS OR ADJUSTMENTS OR PERFORMANCE OF PROCEDURES OTHER THAN THOSE SPECIFIED HEREIN MAY RESULT IN HAZARDOUS RADIATION EXPOSURE.
DO NOT OPEN COVERS AND DO NOT REPAIR YOURSELF. REFER SERVICING TO QUALIFIED PERSONNEL.

¡ADVERTENCIA!

ESTE APARATO UTILIZA UN LASER.
EL USAR LOS CONTROLES, HACER LOS REGLAJES O LOS PASOS REQUERIDOS EN FORMA DIVERSA DE LA AQUÍ EXPUESTA PUEDE REDUNDAR EN EXPOSICIÓN PELIGROSA A LA RADIACIÓN.
NO ABRA LAS TAPAS NI HAGA REPARACIONES USTED MISMO. EN CASO DE PRODUCIRSE ANOMALÍAS SOLICITE AYUDA DE PERSONAL CUALIFICADO.

警告!

本產品使用激光射線。
控制器的使用，調整及操作等如不遵照此處的說明進行，很可能會受到激光射線的危險。勿拆開機殼或自行修理。有問題請交給專業維修人員。

THIS MUSIC SYSTEM IS CAPABLE OF RECEIVING THE NEW AM STEREO BROADCASTS FROM THE AM BAND RADIO STATIONS. HOWEVER LIKE MANY MUSIC SYSTEM CURRENTLY AVAILABLE ON THE MARKET IT WILL REPRODUCE THIS AM STEREO SIGNAL ONLY IN AM MONO, WHICH, IN EFFECT, IS OF NO LESSER QUALITY THAN YOUR EXISTING AM MONO MUSIC SYSTEM.

Suggestions for safety

■ Use a standard AC wall outlet

1. Use from an AC power source of high voltage, such as that used for an air conditioner, is very dangerous. A fire might be caused by such a connection.
2. A DC power source cannot be used. Be sure to check the power source carefully, especially on a ship or other place where DC is used.

■ Grasp the plug when disconnecting the power supply cord

1. Wet hands are dangerous. A dangerous electric shock may result if the plug is touched by wet hands.
2. Never place heavy items on top of the power supply cord, nor force it to bend sharply.

■ Place the unit where it will be well ventilated

Place this unit at least 10 cm (4") away from wall surfaces, etc. Be careful that curtains and similar materials do not obstruct the ventilation holes.

■ Avoid places such as the following:

In direct sunlight or in other places where the temperature is high.

In places where there is excessive vibration or humidity. Such conditions might damage the cabinet and/or other component parts and thereby shorten the unit's service life.

■ Be sure to place the unit on a flat, level surface

If the surface is inclined, a malfunction may result.

■ Never attempt to repair nor reconstruct this unit

A serious electric shock might occur if this unit is repaired, disassembled or reconstructed by unauthorized persons, or if the internal parts are accidentally touched.

■ Take particular care if children are present

Never permit children to put anything, especially metal, inside this unit. A serious electric shock or malfunction could occur if articles such as coins, needles, screwdrivers, etc. are inserted through the ventilation holes, etc. of this unit.

■ If water is spilled on the unit

Be extremely careful if water is spilled on the unit, because a fire or serious electric shock might occur. Immediately disconnect the power cord plug, and consult with your dealer.

■ Avoid spray-type insecticides

Insecticides might cause cracks or "cloudiness" in the cabinet and plastic parts of this unit. The gas used in such sprays might, moreover, be ignited suddenly.

■ Never use alcohol or paint thinner

These and similar chemicals should never be used, because they might cause flaking or cloudiness of the cabinet finish.

■ Disconnect the power supply cord if the unit will not be used for a long time

If the unit is left for a long time with the power ON, this not only will shorten its useful operation life, but also may cause other trouble.

■ If trouble occurs

If, during operation, the sound is interrupted or indicators no longer illuminate, or if an abnormal odour or smoke is detected, immediately disconnect the power cord plug, and contact with your dealer or an Authorized Service Center.

Before Use

(For areas except Australia and New Zealand)

Be sure to disconnect the mains cord before adjusting the voltage selector.

Use a minus (–) screwdriver to set the voltage selector (on the rear panel) to the voltage setting for the area in which the unit will be

(If the power supply in your area is 117 V or 120 V, set to the "127 V" position.)

Note that this unit will be seriously damaged if this setting is not made correctly. (There is no voltage selector for some countries; the correct voltage is already set.)

Supplied accessories

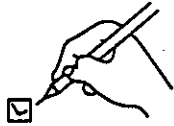

Please check and identify the supplied accessories.



AM loop antenna1 pc.
Antenna holder1 pc.
Screw1 pc.

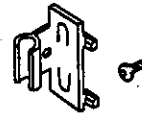

AC power supply cord1 pc.

Note

The configuration of AC power supply cord differs according to area.

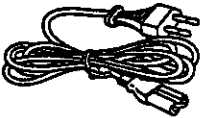

FM indoor antenna1 pc.



Remote control transmitter1 pc.

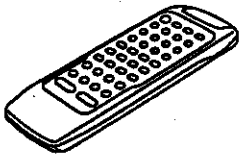

Speaker cords2 pcs.

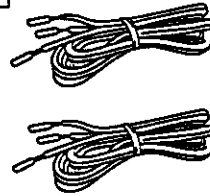

Flat cable (long)1 pc.



Remote control batteries (UM-4, "AAA", R03)2 pcs.

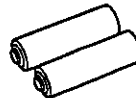

Flat cable (short)1 pc.



Surround speaker cables2 pcs.

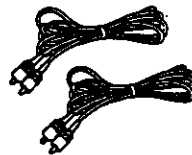

Video connection cable1 pc.
(For areas except Australia and New Zealand)



Power plug adaptor1 pc.
(For areas except Australia and New Zealand)

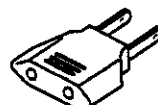

Location of controls

If you have not yet installed and connected this system, go straight to pages 16–26.

The functions indicated by the numbers with black background (for example ❶) can also be activated from the remote control transmitter. (See pages 158–161.)

Amplifier section

- ❶ **Power “STANDBY \odot /ON” switch**
(POWER, STANDBY \odot /ON)
Press to switch the unit from on to standby mode or vice versa. In standby mode, the unit is still consuming a small amount of power.
- ❷ **Standby indicator (STANDBY)**
When the unit is connected to the AC mains supply, this indicator lights up in standby mode and goes out when the unit is turned on.
- ❸ **Volume control**
- ❹ **Headphones jack**
- ❺ **Range select button**
- ❻ **Microphone jack**
- ❼ **Microphone volume control**
- ❽ **Display mode button**
- ❾ **Microphone jack**
(For areas except Australia and New Zealand)

(To be continued)

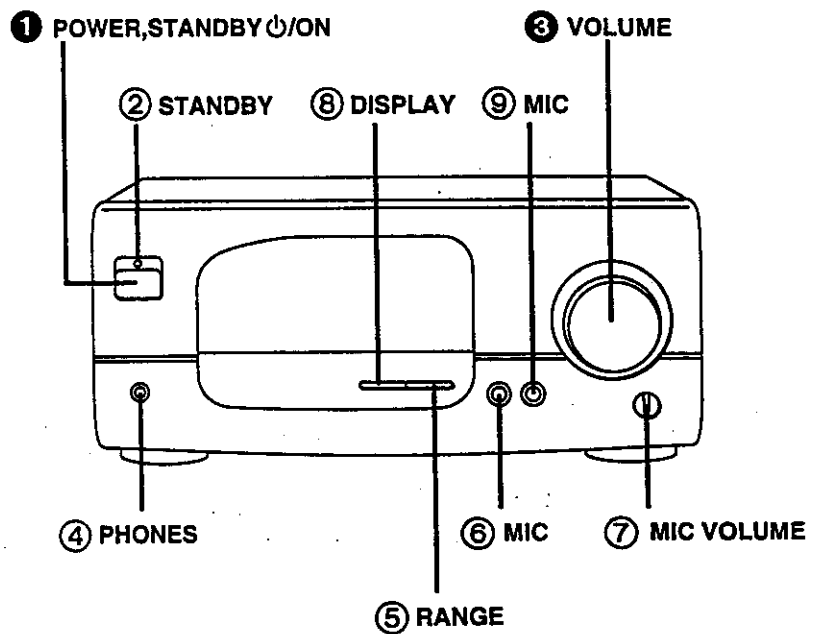
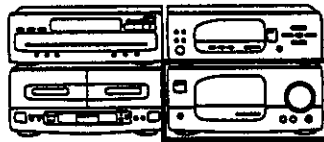

Location of controls

(Continued)

Compact disc changer section

A

- 1 Disc buttons
- 2 Stop button
- 3 Skip/search buttons
- 4 Loading drawer open/close button
- 5 Compact disc edit buttons
- 6 Display button
- 7 Random play button
- 8 Repeat play button
- 9 Pause button
- 10 Play button and indicator

CD Graphics (For areas except Australia and New Zealand)

This unit has CD Graphics function. You can enjoy karaoke complete with visual imagery and the text by connecting your TV set to this unit. Use CDs marked **GRAPHICS** to enjoy CD graphics.

(See page 26.)

A

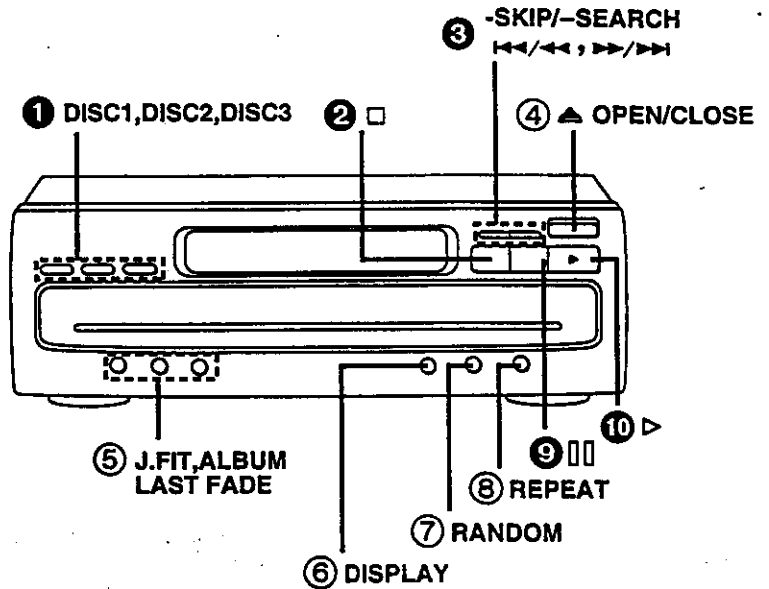
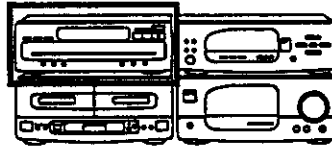

Tuner/sound processor section

B

- 1 Record timer button
- 2 External source input select button
- 3 Internal source input select button
- 4 Play timer button
- 5 EQ/SPACE mode ON/FLAT button
- 6 Tuner source/band select button and Indicator
- 7 Multi-control buttons
- 8 Remote control signal sensor
- 9 V. bass button
- 10 Voice mute button
- 11 Echo button
(For areas except Australia and New Zealand)
- 12 EQ/SPACE mode select button
- 13 Clock/timer button

(To be continued)

B

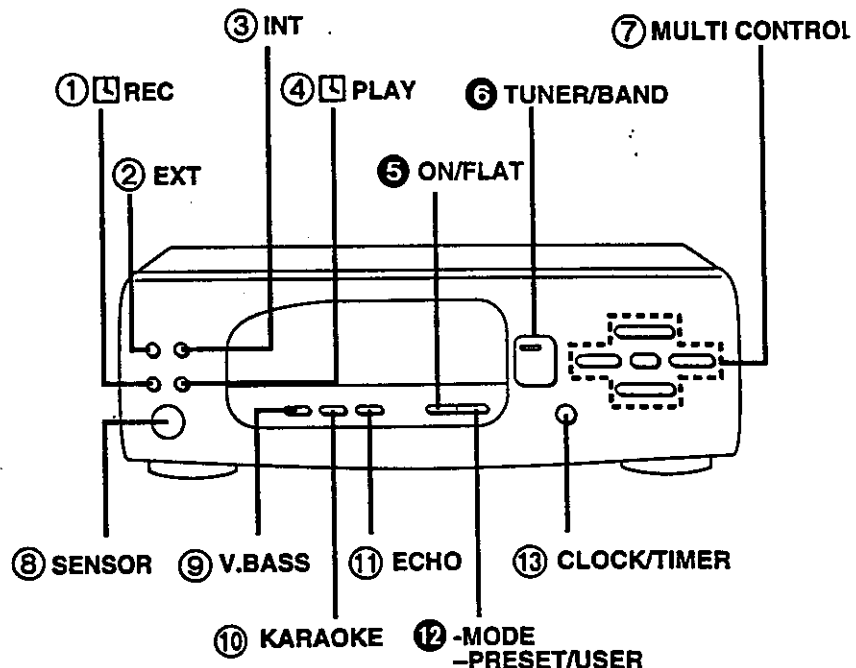
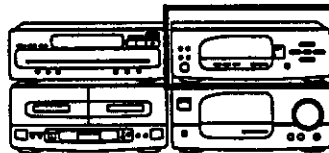

Location of controls

(Continued)

Cassette deck section

- ① Deck 1 cassette holder
- ② Dolby noise reduction button and indicators
- ③ Deck 1/deck 2 select button and indicators
- ④ Deck 1 cassette holder close button
- ⑤ Fast forward/rewind/tape program sensor buttons
- ⑥ Deck 2 cassette holder close button
- ⑦ One-touch tape edit buttons
- ⑧ Deck 2 cassette holder
- ⑨ Deck 1 cassette holder open button
- ⑩ Reverse mode button and indicators
- ⑪ Playback buttons and indicators
- ⑫ Stop button
- ⑬ Record pause button and indicator
- ⑭ CCRT button and indicator
- ⑮ Deck 2 cassette holder open button

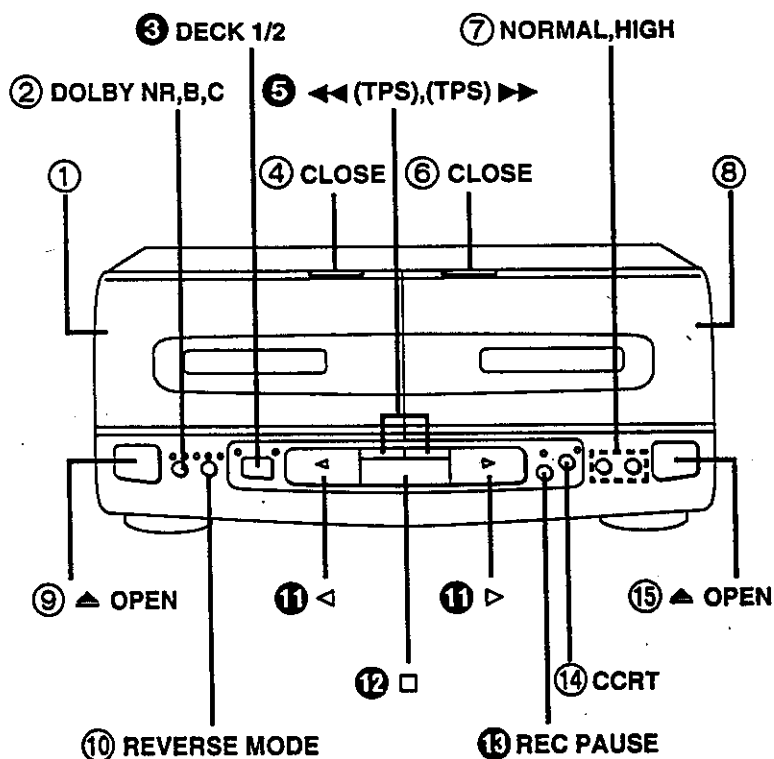
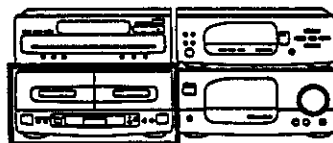

Installation

Stacking the components

Install the various components as shown below.

Horizontal stacking **A**

Vertical stacking **B**

System layout example **C**

To produce a better stereo sound, install both speakers away from the system.

Since this speaker system has built-in surround speakers, you can easily enjoy the surround sound effect when you select SPACE mode (page 118) or ECHO mode (page 146). (ECHO mode—for areas except Australia and New Zealand)

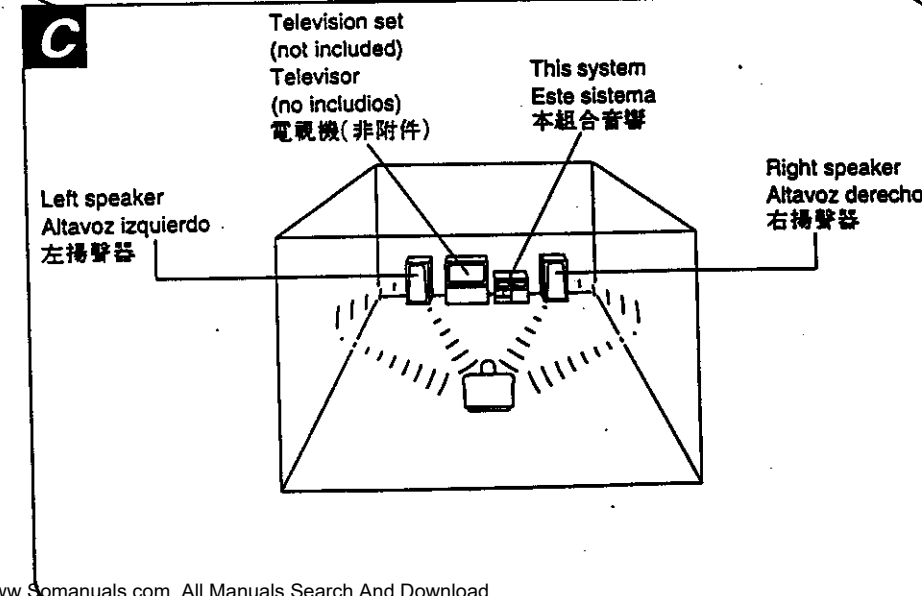
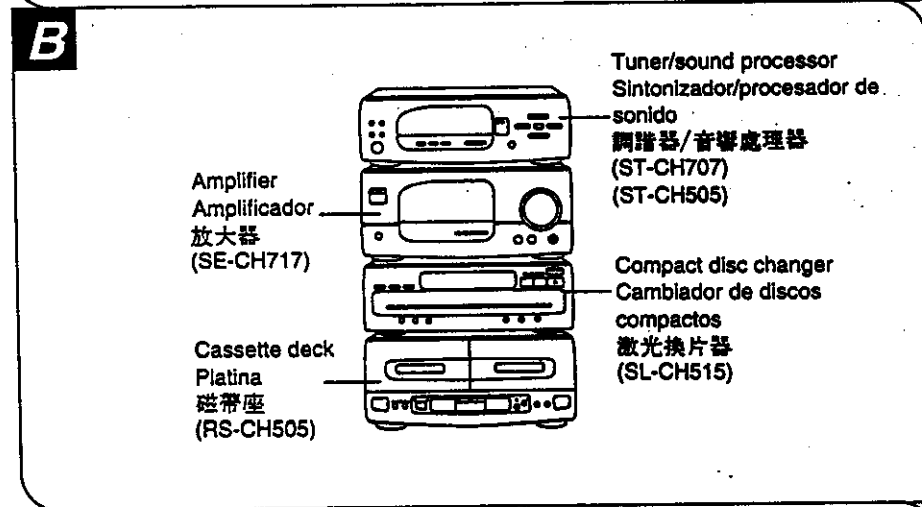
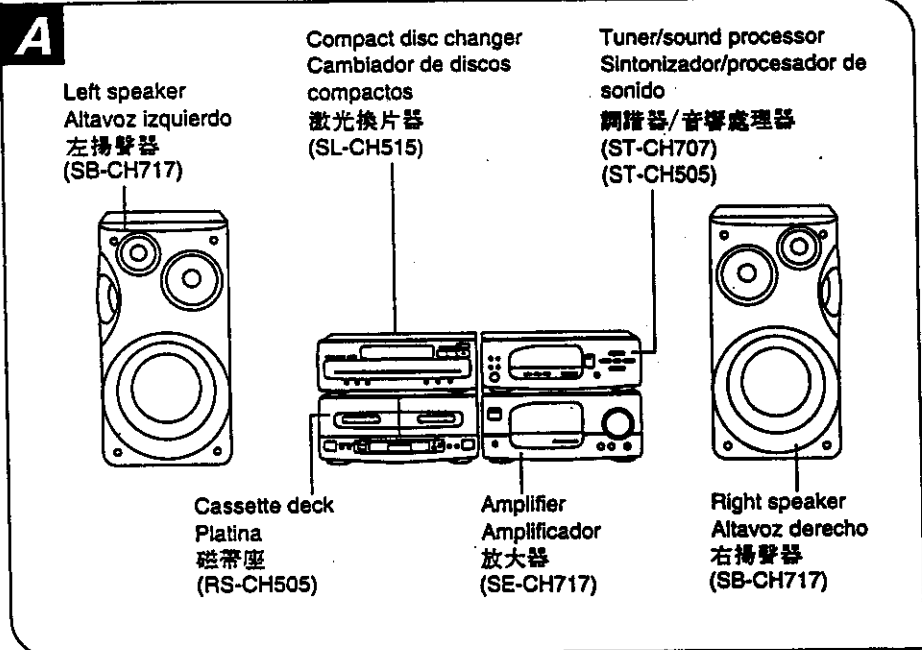

Connections

1 Connect the flat cables.

Hold the connector with the recessed part up and press in at the center until you hear a click.

1. Connect the shorter flat cable to the terminal of the tuner/sound processor and amplifier.
2. Connect the longer flat cable to the terminal of the tuner/sound processor, compact disc changer, and cassette deck.
Route the cable horizontally (underneath the heat outlet grille) so that the side with the white-color lead is positioned at the front.

Be sure to connect the blue-colored connector to B1 (tuner/sound processor).
After connection, hold and press the cable as flat to the back of the unit as possible.

Do not try connecting or disconnecting the flat cables while the power is switched to ON.

- 2 Connect the FM indoor antenna.
Install the antenna on a wall at a height and in a direction which result in the best reception.
The tip of the internal antenna wire should not come into contact with any metal objects.
When you cannot get a good reception with this FM indoor antenna, we recommend you install an FM outdoor antenna (not included). (See page 24.)

(To be continued)

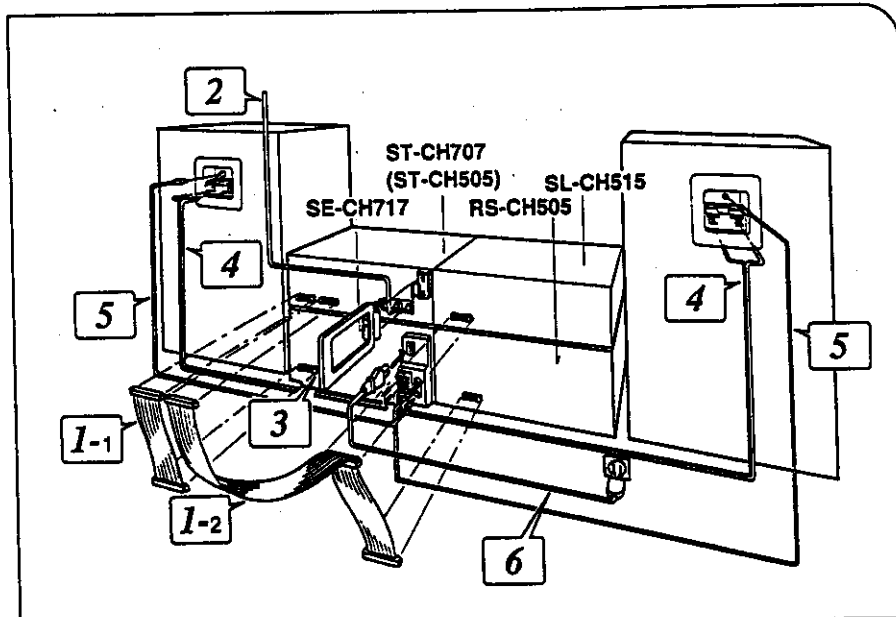

1

Connecting
Conexión
連接



Disconnecting
Desconexión
拆開

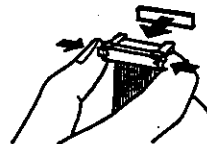

Heat outlet grille
Rejilla de escape de calor
排熱孔格柵

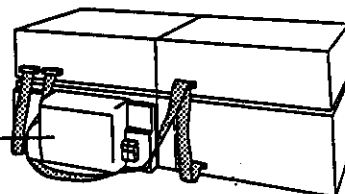

2

Adhesive tape
Cinta adhesiva
膠帶

FM indoor antenna (included)
Antena interior de FM (incluida)
FM 室內天線(附件)

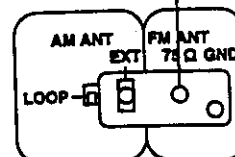

Connections

(Continued)

3 Connect the AM (MW/LW) loop antenna.

1. Attach the antenna holder to the rear panel of the tuner/sound processor.
2. Clamp the antenna to the antenna holder and connect the antenna terminal to the rear panel of the tuner/sound processor.
3. Position the loop for the best reception.

You may attach the antenna holder to a rack or other structure. Use a screw (included) to attach as shown in the figure. **A**

Note

To minimize noise pickup, keep the AM loop antenna cord away from the flat cables.

(To be continued)

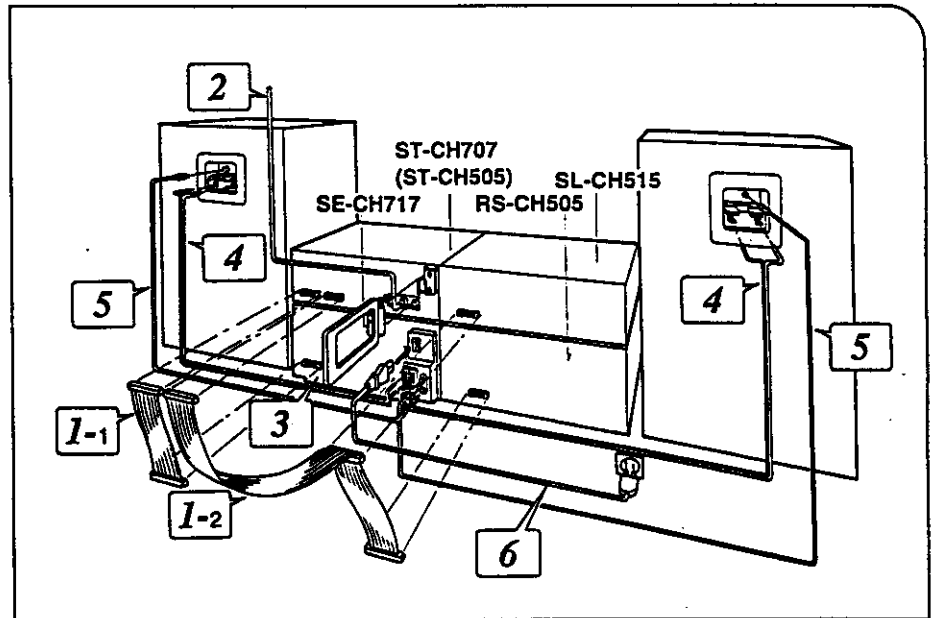

3

Press in until you hear a click.
Presione hacia adentro hasta que oiga un ruido seco.
按入，直至咔嚓一聲到位。

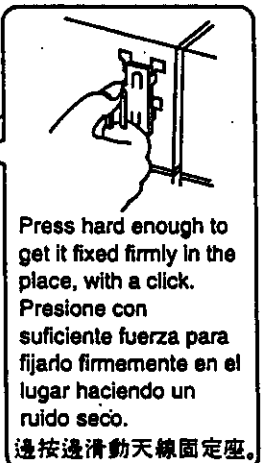
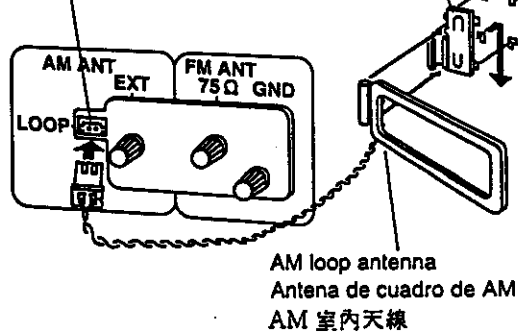

A

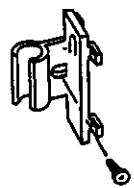

Connections

(Continued)

4 Connect the right (R) and left (L) speaker cables.

Note

Be sure to connect speaker cables before connecting the AC power supply cord.

•The load impedance of any speaker used with this unit must be 6–8 ohms.

Connection of speaker cables **A**

1. Strip off the outer covering, and twist the center conductor. Make sure the bare ends of the wires are not unraveled. (If they are, twist them tight again.)
2. Insert the wire to the rear panel of the speakers, and then pull down the levers.
3. Insert the wire to the rear panel of the amplifier, and close the lever.

Notes

- To prevent damage to circuitry, never short-circuit positive (+) and negative (–) speaker wires.
- Be sure to connect only positive (red) wires to positive (+) terminals and negative (black) wires to negative (–) terminals.

5 Connect the surround speaker cords. **B**

6 Connect the AC power supply cord after you have connected all other cables and cords.

(For areas except Australia and New Zealand)

Insertion of Connector: **C**

Even when the connector is perfectly inserted, depending on the type of inlet used, the front part of the connector may jut out as shown in the drawing. However there is no problem using the unit.

For areas except Australia and New Zealand **D**

If the power plug will not fit your socket, use the power plug adaptor (included).

(To be continued)

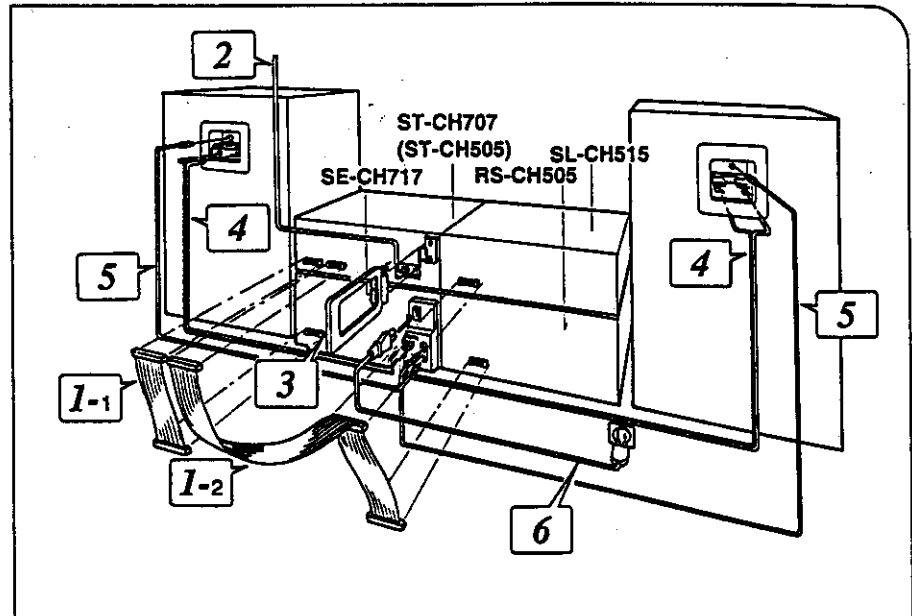

4

A

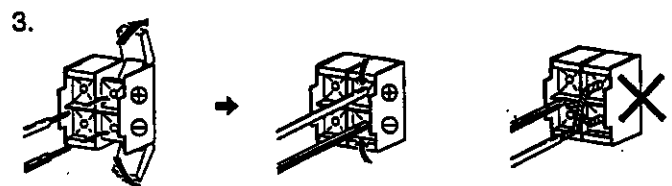
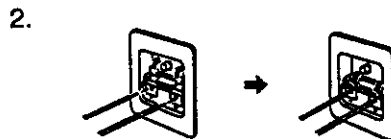
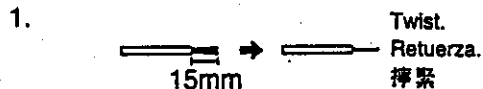

B

Rear panel of the amplifier
Panel trasero del amplificador
放大器後板

Rear panel of the speakers
Panel trasero de los altavoces
揚聲器後板

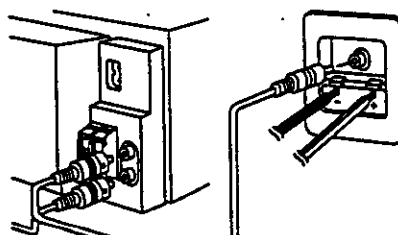

C

Appliance inlet
Toma del aparato
適用插座

Connector
Conector
連接器

Approx. 6 mm
Aprox. 6 mm
約: 6 毫米

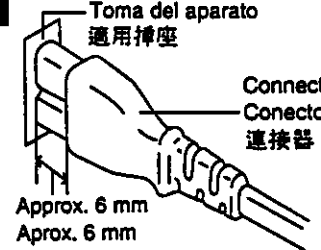

D

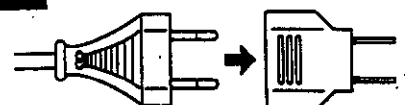

Connections

(Continued)

Optional antenna connections

FM outdoor antenna (not included)

A

If the FM indoor antenna does not provide satisfactory reception of FM broadcasts, use an outdoor antenna.

You may need an outdoor antenna if you use this system in a mountainous region or inside a reinforced-concrete building, etc. An outdoor antenna should be installed by a competent technician only.

Connection of the FM outdoor antenna

1. Remove a piece of the outer vinyl sheath from the end.
2. Bundle the shield braid, and remove a piece of the inner vinyl sheath covering the core wire.
3. Connect the core wire and the shield braid.

AM (MW/LW) outdoor antenna (not included) **B**

An outdoor antenna may be required in a mountainous region, or if this system is located inside a reinforced-concrete building, etc.

Run 5 to 12 m of vinyl-covered wire horizontally along a window or other convenient location.

Note

Do not remove the AM loop antenna.

(To be continued)

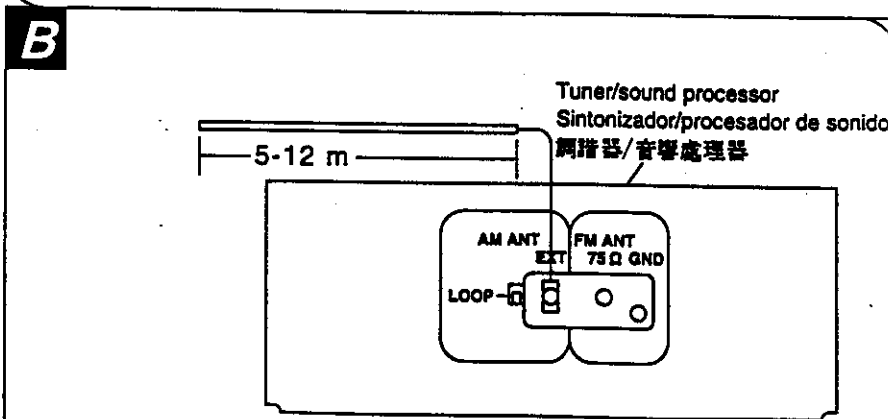
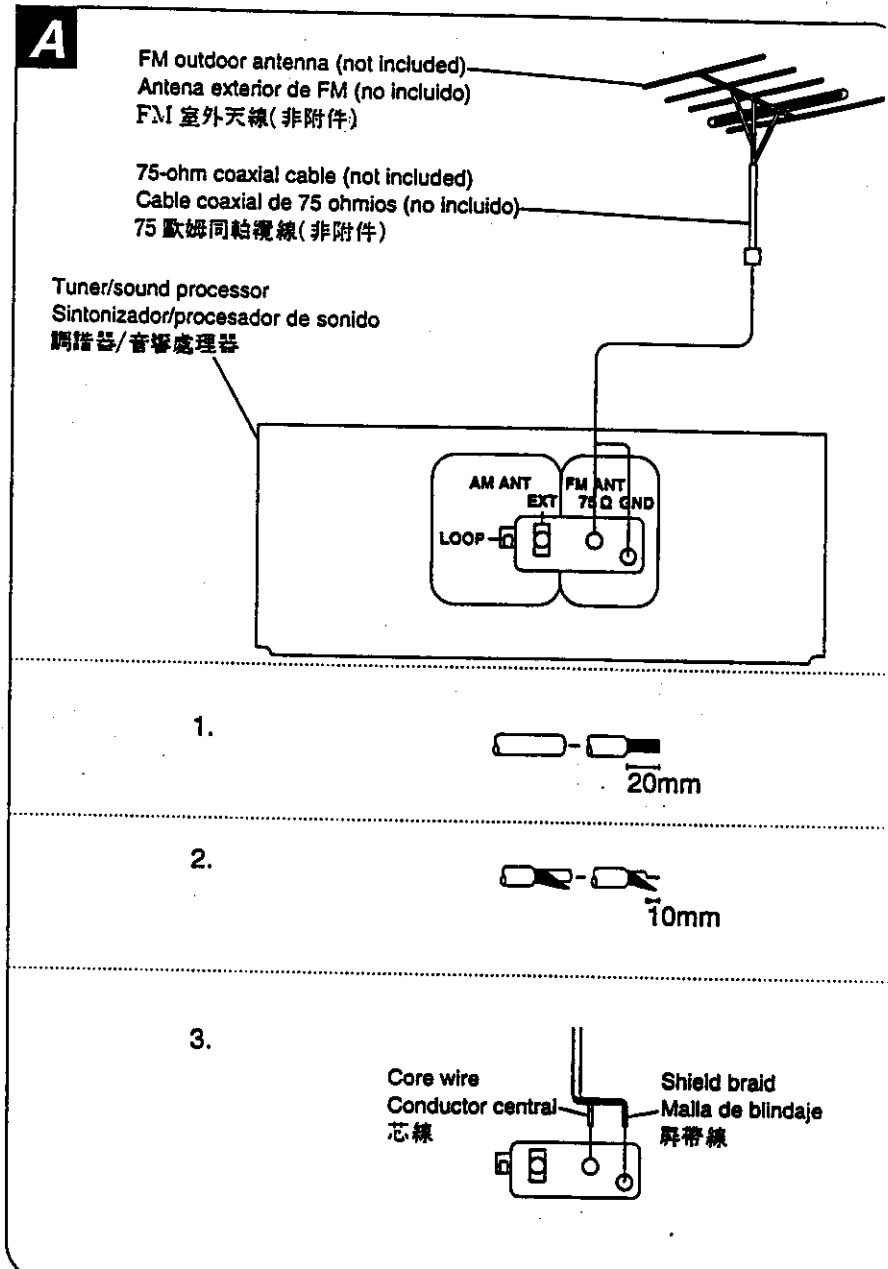

Connections

(Continued)

External unit connection

DCC (digital compact cassette deck)

A

Analog player **B**

CD graphics (For areas except Australia and New Zealand) **C**

"CD graphics" refers to CDs containing pre-recorded still-picture data and the text in addition to their music, and it is mainly used for karaoke.

You can enjoy karaoke complete with visual imagery by connecting your TV set to this unit.

1. Connect the TV set to this unit.
2. Set the TV's TV/VCR selector to the "video" position.
3. Proceed with steps 1 to 4 (on page 146) in the section on "Karaoke".

Notes

- Use CDs marked **GRAPHICS** to enjoy CD graphics. No picture will appear with CDs which are not marked in this way.
- Skipping forward or backward during CD graphics play may cause the picture to shift for a short period of time. This is not indicative of malfunctioning. If play is left to continue, the picture will return to normal.
- This unit does not come with a graphics channel selection or fade-out function.
- Set the CD changer according to the television set.
NTSC: When receiving NTSC signals
PAL: When receiving PAL signals
- For details, see the operation manual of the television set.

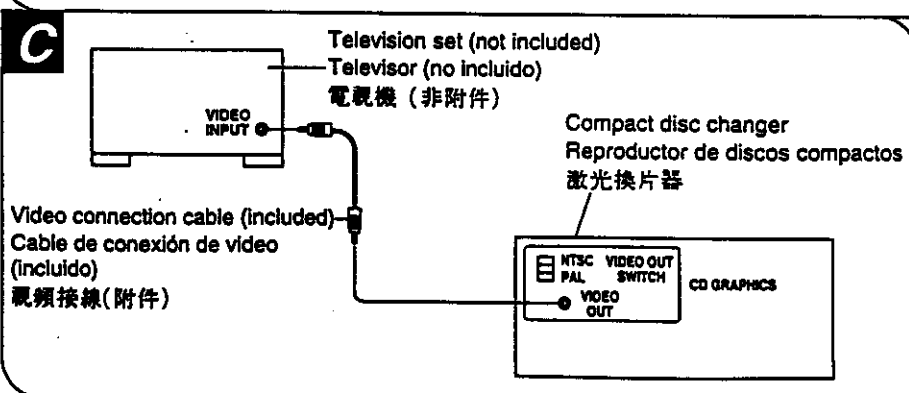
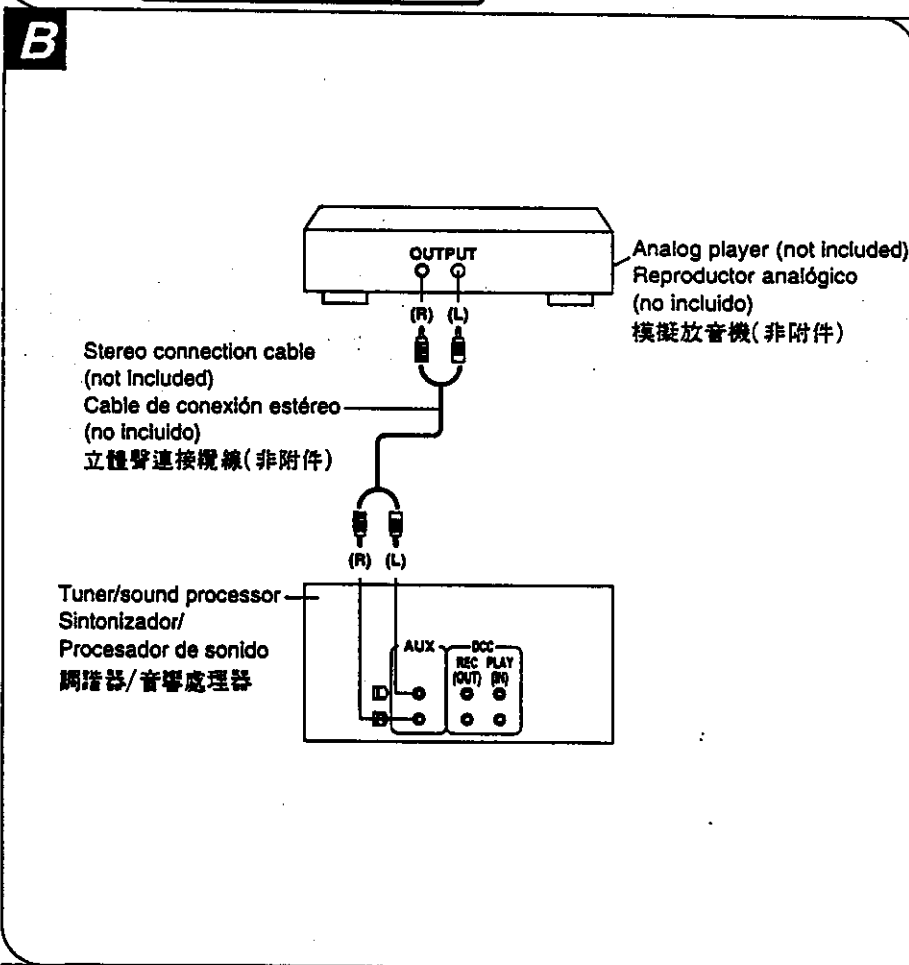
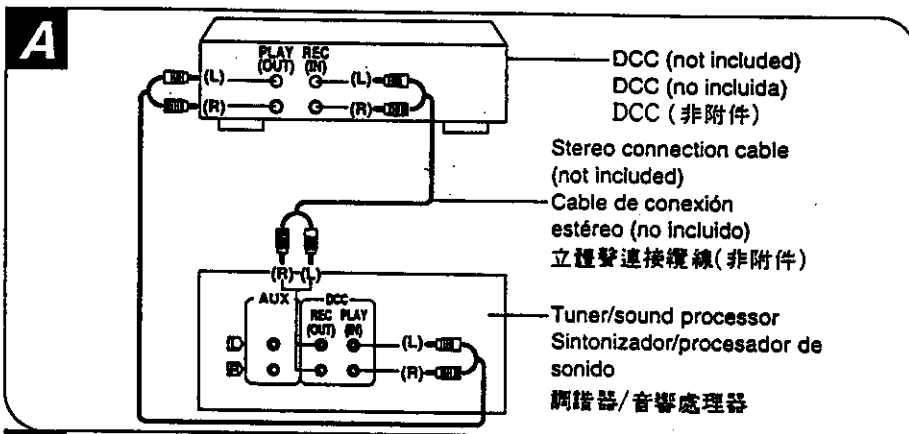

Concerning the multi-control section

Using the multi-control buttons, you can make following operation.

- Clock/timer settings
- Tuning or presetting the radio station
- Selecting or adjusting the EQ or SPACE mode
- The reverberation time adjustment (ECHO—for areas except Australia and New Zealand)

When operating, the display shows which buttons are available for the operation.

The chart below shows the display and the available buttons for each operation.

Clock/timer operation **A**

- Time setting (See page 34.)
- Record timer setting (See pages 134, 136 and 138.)
- Play timer setting (See pages 128, 130 and 132.)
- Sleep timer setting (See page 140.)

Radio operation **B**

- Automatic memory presetting (See pages 36 and 38.)
- Manual memory presetting (See page 40.)
- Manual tuner operation (See page 42.)
- Memory tuner operation (See page 42.)

EQ/SPACE operation **C**

- The EQ/SPACE mode selection (See pages 114, 116, 118 and 120.)
- The EQ/SPACE mode effect adjustment (See page 122.)

ECHO operation (For areas except Australia and New Zealand) **D**

"ECHO" effect adjustment (See page 146.)

(To be continued)

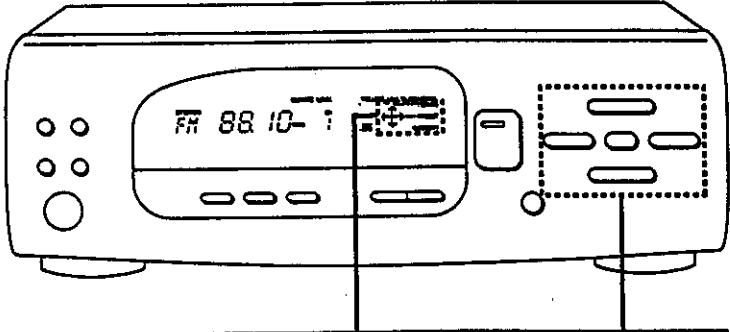

	Display Visualización 顯示	Available buttons Botones utilizables 適用鈕
A	MULTI CONTROL ← → ↙ SELECT SET ●	MULTI CONTROL ▲ ← SET → ▼
B	MULTI CONTROL TUNING ↕ PRESET ● MEMORY	MULTI CONTROL ▲ ← SET → ▼
C	MULTI CONTROL ↕ EFFECT ← → ↙ SELECT	MULTI CONTROL ▲ ← SET → ▼
		MULTI CONTROL ▲ ← SET → ▼
D	MULTI CONTROL ↕ EFFECT	MULTI CONTROL ▲ ← SET → ▼

Concerning the multi-control section

(Continued)

Demonstration function **A**

By keeping pressed V. BASS, the demonstration example shows on the display alternately.

Press and hold V. BASS.

The display will change alternately showing the display example when the multi control buttons are used.

To cancel, press any button on the system.

About the illumination guide **B**

Orange indicators on the buttons guide you to the easiest steps toward listening pleasure.

- To listen to a radio broadcast: **C**
- To listen to a compact disc: **D**
- To listen to a tape: **E**

A

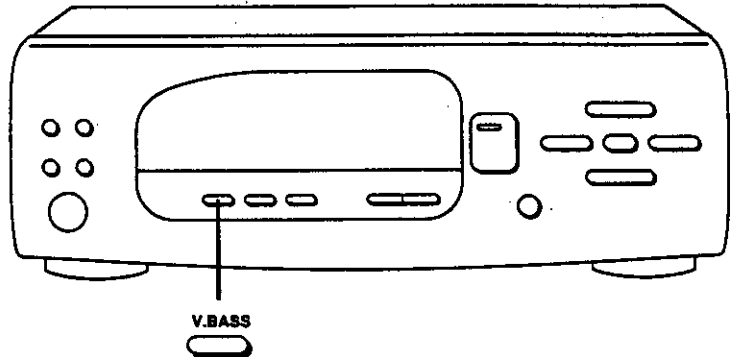

B

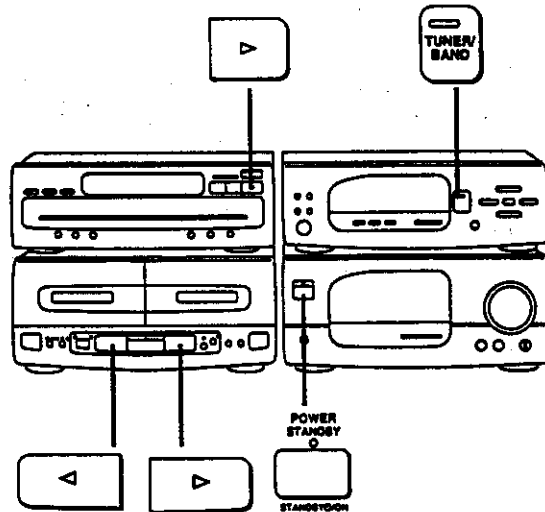

C

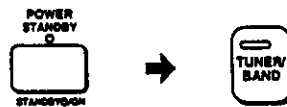

D



E



Concerning the remote control

Battery installation **A**

Use of batteries

- Do not mix old and new batteries, or batteries of different types (carbon and alkaline, etc.).
- Never subject batteries to excessive heat or flame; do not attempt to disassemble them; and be sure they are not short-circuited.
- If the remote control is not to be used for a long period of time, remove the batteries and store them in a cool, dark place.
- Do not attempt to recharge alkaline or carbon batteries.

Battery life

The battery life is about one year.

The batteries should be replaced if commands from the remote control transmitter do not operate the unit even when the transmitter is held close to the front panel.

Correct method of use **B**

Operation notes

- Aim the remote control's transmission window toward the unit's sensor. Avoid any obstacles.
- Be sure the transmission window and the unit's sensor are free from dust. Excessive dust might affect its performance.
- The operation may not be correct if direct sunlight or other strong light source strikes the receiving sensor of this unit. If there is a problem, place the unit away from the light source.
- If this system is installed in a rack with glass doors, the glass doors' thickness or color might make it necessary to use the remote control a shorter distance from the system.
- Never place heavy items.
- Do not disassemble or reconstruct.
- Do not spill water or other liquids.

A

Insert the batteries in the correct polarities (⊕, ⊖).
 Inserte las pilas colocando correctamente las polaridades (⊕, ⊖).
 要極性(⊕、⊖)正確地插入電池。

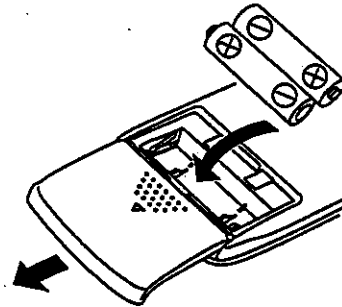

To remove the batteries, pull out the ⊕ side.
 Para extraer las pilas, saque el lado ⊕.
 取出電池時，拉⊕極邊。

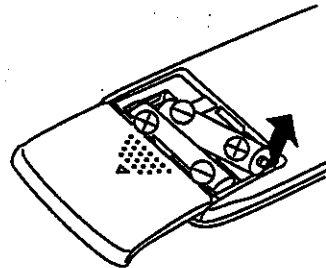

B

Remote control signal sensor
 Sensor de señales del mando a distancia
 遙控信號感應器

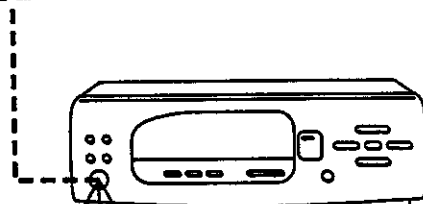

Tuner/sound processor
 Sintonizador/procesador de sonido
 調諧器/音響處理器

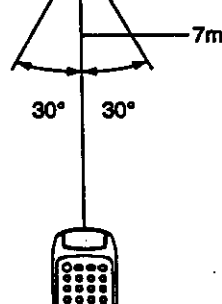

Setting the time

This is a 24-hour display clock.
These instructions explain how to set the timer for 16:25 (4:25 p.m.) on Wednesday.

- 1 Switch on the power on the amplifier.
- 2 ① Press CLOCK/TIMER to select "CLOCK".
Within 7 seconds:
② Press SET.
- 3 ① Press ► or ◀ to select "WED".
② Press SET.
- 4 ① Press ► or ◀ to select "16".
② Press SET.
- 5 ① Press ► or ◀ to select "25".
② Press SET to finish setting the time.

The display will return to the previous display after about 2 seconds.

When "E:" appears on the display:
It appears when you connect the power supply cord for the first time or if there has been a power failure.
If this happens, reset the time.

If the minutes setting has gone wrong:

1. Press CLOCK/TIMER.
2. Press SET 3 times.
3. Press ► or ◀ to set the minute, and then press SET.

For your reference:
To display the clock again:
Press CLOCK/TIMER.
The clock display will appear for about 7 seconds.

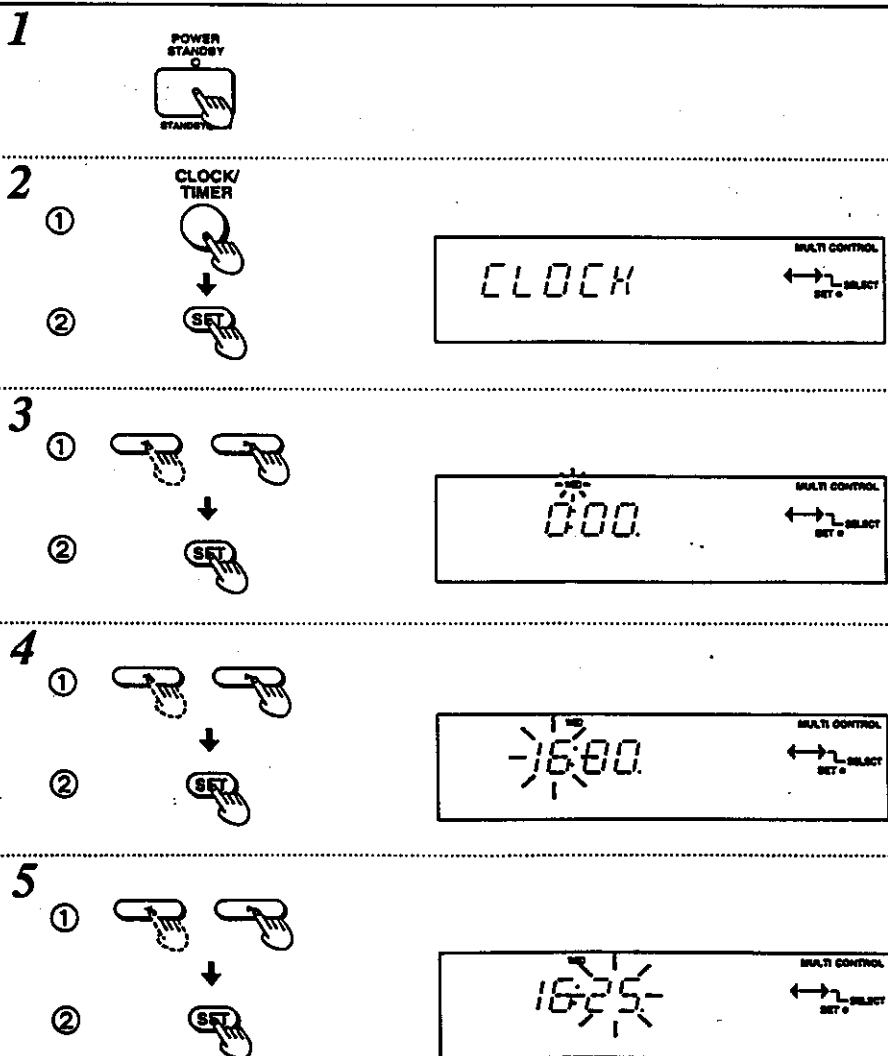
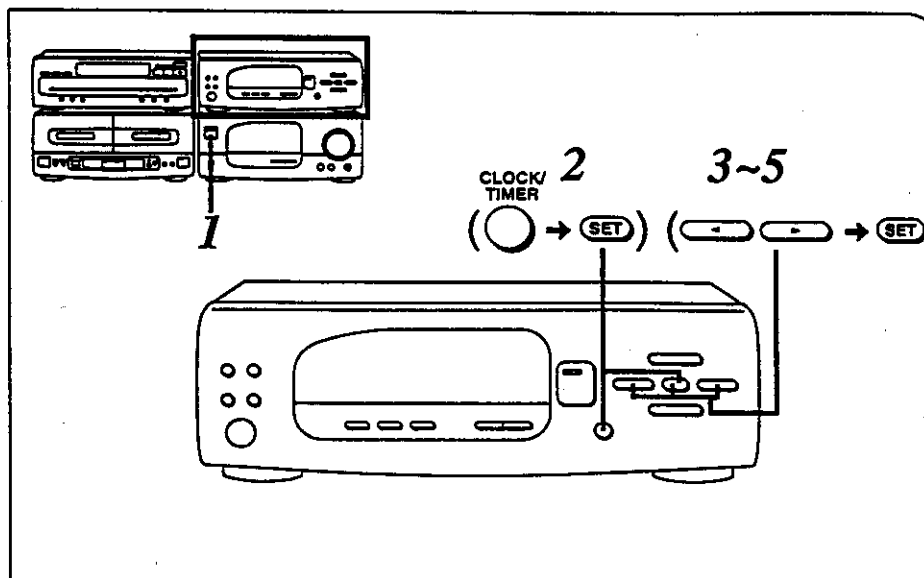

Memory presetting

This feature allows you to set broadcast frequencies into the memory. You can then easily retrieve any of those broadcast frequencies by pressing ► or ◀ on the tuner/sound processor.

Automatic memory presetting





The frequencies of the selected broadcast stations are automatically preset (in sequence from lower to higher frequencies) into the memory: "channels" 1 to 39 are available for the presetting of FM stations, "channels" 21 to 39 are available for MW stations and "channels" 31 to 39 are available for LW stations.

- 1** Switch on the power on the amplifier.
- 2** Press TUNER/BAND to select FM.
Each time you press TUNER/BAND, "FM", "MW", "LW" will appear in order.
- 3** Press and hold ▲ or ▼ until the display shows the frequency from which you want to begin automatic memory presetting.
Press ▲ or ▼ momentarily to stop changing frequencies when the displayed frequency approaches the lowest frequency. Press ▲ or ▼ a few times until the lowest frequency is reached.
- 4** Press and hold SET and the automatic memory presetting will begin.
Keep SET depressed until MEMO indicator starts flashing, then release the button.

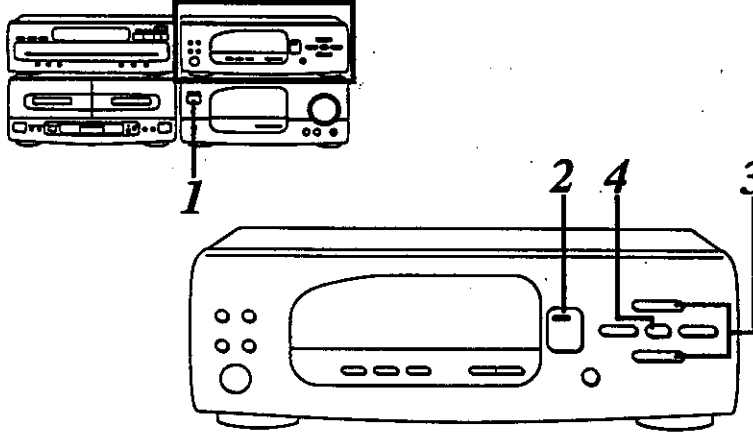
After completing the memory presetting, MEMO indicator will go out and the display will show the last preset frequency.

(To be continued)

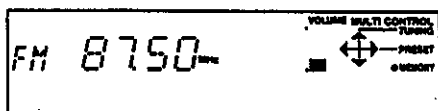

- 1**

- 2**

- 3**

- 4**

Lights when an FM stereo broadcast is being received.
Se enciende cuando se recibe una emisión en estéreo por FM.
當接收 FM 立體聲廣播時亮起。



Flashes.
Parpadea.
閃爍

Lights when you precisely tune in a broadcast station.
Se enciende cuando se sintoniza con precisión una emisora de radiodifusión.
當進行廣播電台微調時亮起。

Memory presetting

(Continued)

To preset MW, LW broadcast frequencies into the memory:

(See page 36.)

1. Select MW in step 2, then follow steps 3 and 4.
2. Select LW in step 2, then follow steps 3 and 4.

To confirm the preset stations:

Press ► or ◀.

Note

When you preset a broadcast station to a channel that has already been preset, the previous presetting will be erased. So if, for example, FM frequencies are preset from channel 1 to 39 and then MW frequencies are preset, the first MW frequency will be preset to channel 21 (thus erasing the FM presetting to channel 21), the second MW frequency will be preset to 22 (erasing FM 22), and so on.

About the TUNER/BAND indicator:

While listening to radio broadcasts:

Lights in green.

While listening to compact discs or tapes:

Lights in orange.

Preset memory contents maintenance:

The contents of the memory will continue to be stored for approximately 2 weeks, even if the power supply cord is disconnected.

Correct presetting may not be possible in cases where the broadcast waves are too strong or too weak. In such cases, carry out presetting manually. (See page 40.)

(To be continued)

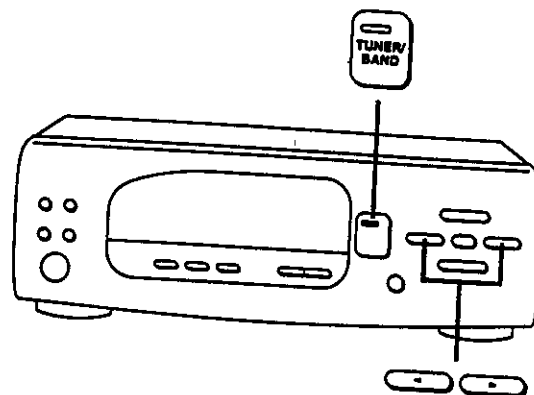
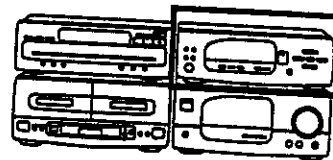

Memory presetting

(Continued)

Manual memory presetting

This example shows how to memorize FM 88.10 MHz into preset channel 1.

This feature allows you to preset manually preset stations into any desired channel.

- 1 Press TUNER/BAND to select FM or MW or LW.
Each time you press TUNER/BAND, "FM", "MW", "LW" will appear in order.
- 2 Press ▲ or ▼ to tune in to the desired broadcast.
- 3 Press SET momentarily.
- 4 Press ► or ◀ to select the desired preset channel.
- 5 Press SET momentarily.
MEMO indicator will go out.

Automatic scanning:

Press and hold ▲ or ▼ until the displayed frequency begins to change.

•The changing of the displayed frequency will automatically stop if a broadcast station frequency is located during the tuning process.

•When there is excessive interference, the automatic scanning may not function.

To cancel the automatic scanning, press ▲ or ▼ once again.

To preset FM stations in monaural position:

1. Select the desired frequency.
2. Press FM MODE on the remote control to show "MONO". (See page 44.)
3. Follow the procedure 3-5 above.

About the frequency step:

Each time you press ▲ or ▼, the frequency display will change as follows:

FM: 0.05 MHz step

MW: 9 kHz or 10 kHz step

(To change the MW allocation, see page 44.)

LW: 9 kHz step

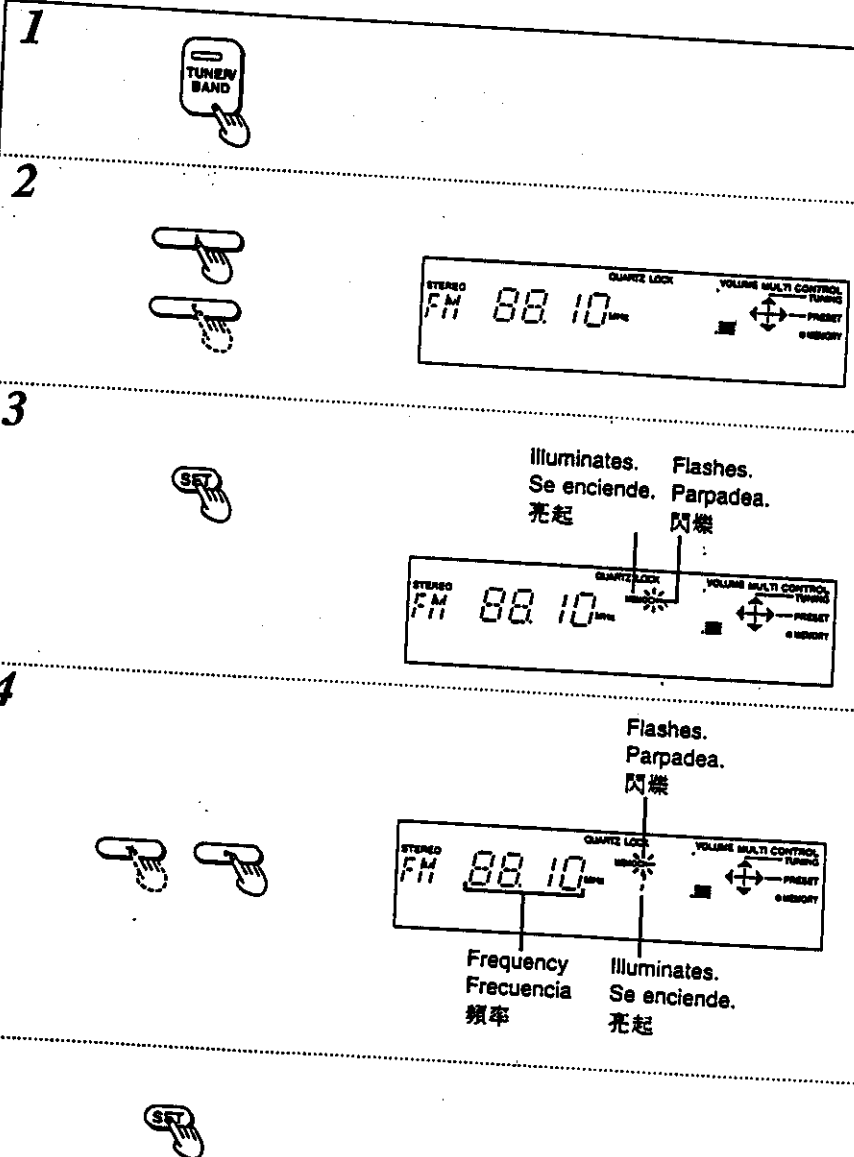
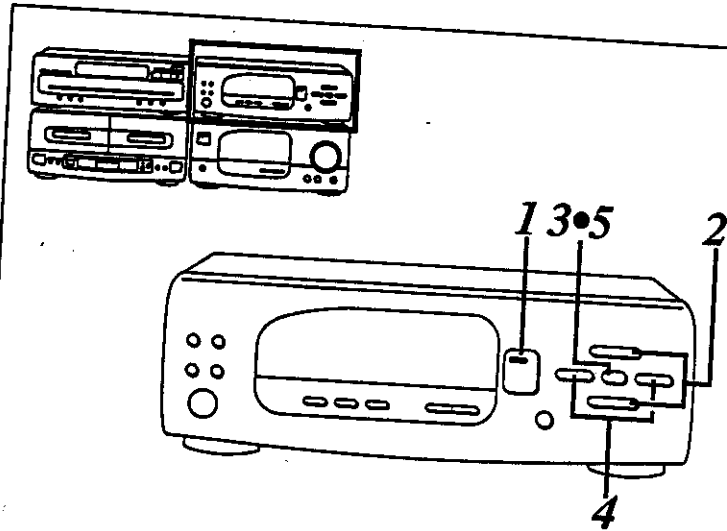

Listening to radio broadcasts

Manual tuner operation **A**

- 1 Switch on the power on the amplifier.
- 2 Press TUNER/BAND to select FM or MW or LW.
Each time you press TUNER/BAND, "FM", "MW", "LW" will be displayed in order.
- 3 Press ▲ or ▼ to tune into the desired broadcast.
The display will show the frequency which you selected.
- 4 Adjust the volume as you like on the amplifier.

Memory tuner operation **B**

Switch on the power and be sure you've completed the steps of "Automatic memory presetting" on page 36 or "Manual memory presetting" on page 40.

This example shows how to tune in to the preset channel 1.

Press ► or ◀ to select the desired preset channel.

The selected preset channel will appear on the display.

(To be continued)

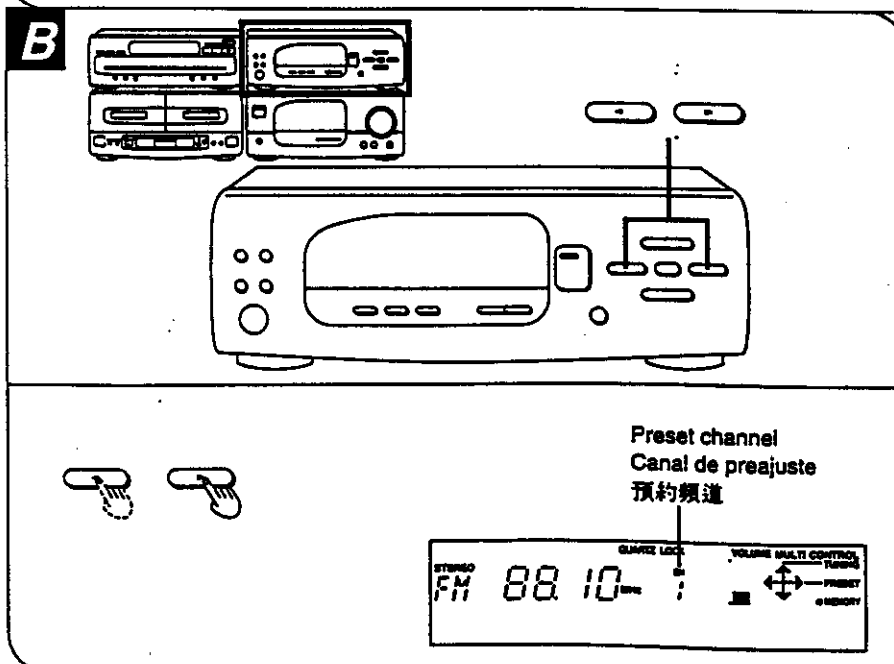
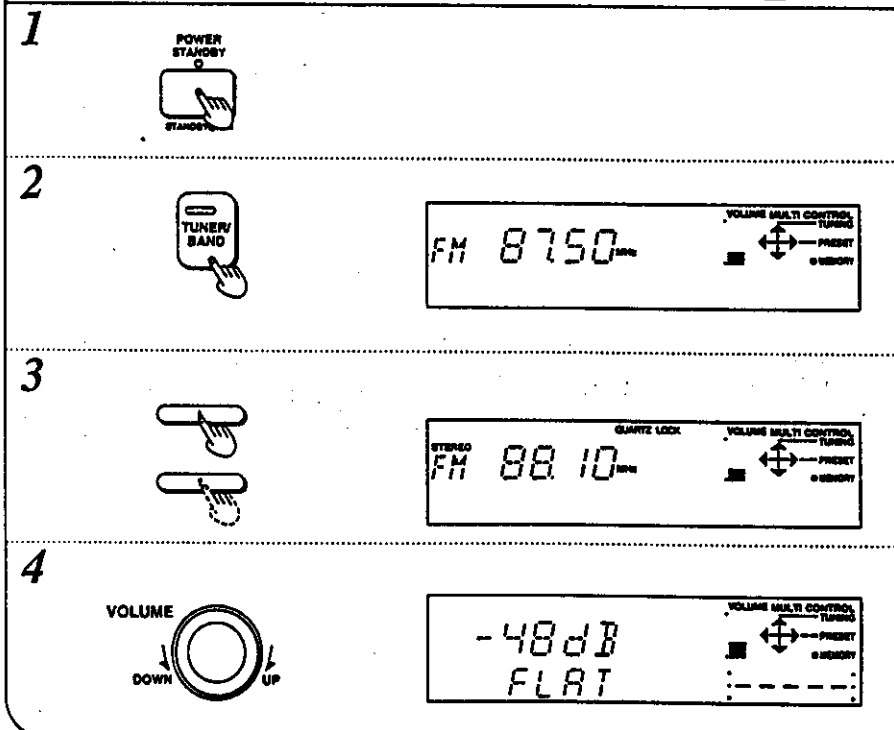
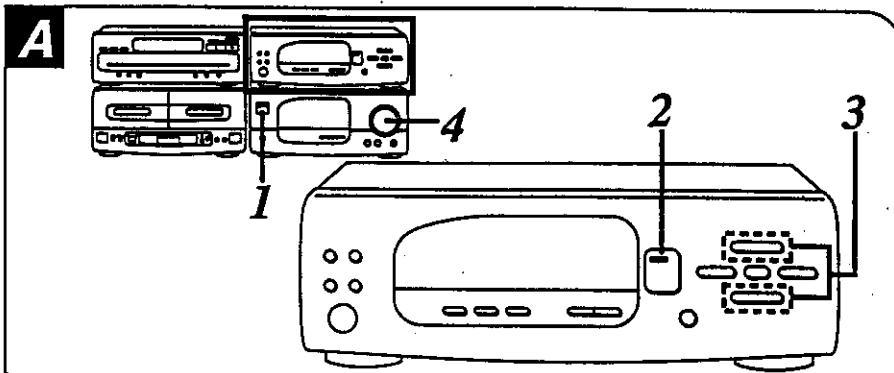

Listening to radio broadcasts

(Continued)

If noise is excessive in the FM mode:
Press FM MODE.

The sound will then be heard in monaural. If the broadcast signal is weak, or if there is a large amount of interference, you will get a clearer sound using FM MODE.

MW allocation settings:

(Only on the main unit)

This unit comes equipped with an electronic digital tuner that divides the broadcast band into many small steps. These steps match the assignable broadcast frequencies and intervals in between.

Each country allocates (assigns) broadcast bands according to their particular needs.

By adjusting the allocation, you can enable this tuner to receive MW broadcasts allocated in 10 kHz steps.

1. Press TUNER/BAND to select MW.
2. Press and hold TUNER/BAND for approximately 4 seconds.

To return to the original frequency indication, repeat steps 1 and 2.

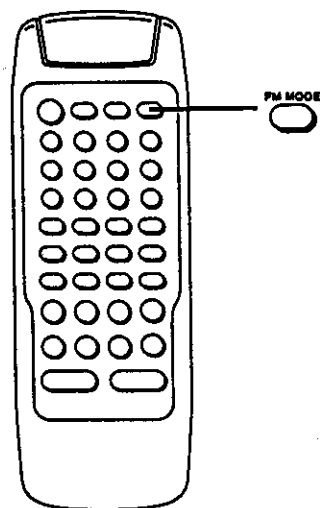

MONO lights.
Se enciende MONO.
MONO (單聲)亮起。

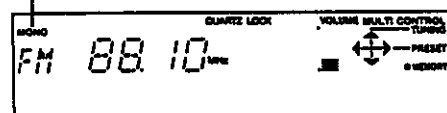

Listening to compact discs

Sequential play

Sequential play refers to play all tracks on the loaded discs in sequence beginning with the first track of the first disc and continuing in order to the last track of the last disc.

- 1 Switch on the power on the amplifier.
- 2 Press \blacktriangle OPEN/CLOSE to open the loading drawer.
- 3 Load the disc(s) on the disc tray(s).
Do not load 8 cm (3") and 12 cm (5") discs on the same disc tray.
Be sure to load a 8 cm (3") disc correctly at center position.
- 4 Press \blacktriangle OPEN/CLOSE to close the loading drawer.
- 5 Press \blacktriangleright .
Disc play begins from the first track on the first disc.
Play stops automatically when the last track on the last disc finishes playing.
- 6 Adjust the volume level as you like on the amplifier.

To stop the disc play:
Press \square .

To temporarily stop the disc play:
Press \square .
 \blacktriangleright indicator flashes.
To play again, press \blacktriangleright .

For your reference:
If you press \blacktriangleright instead of \blacktriangle OPEN/CLOSE after inserting disc(s), the loading drawer will close and play will start directly.
The compact disc will automatically stop when a different sound mode is selected during its operation.

(To be continued)

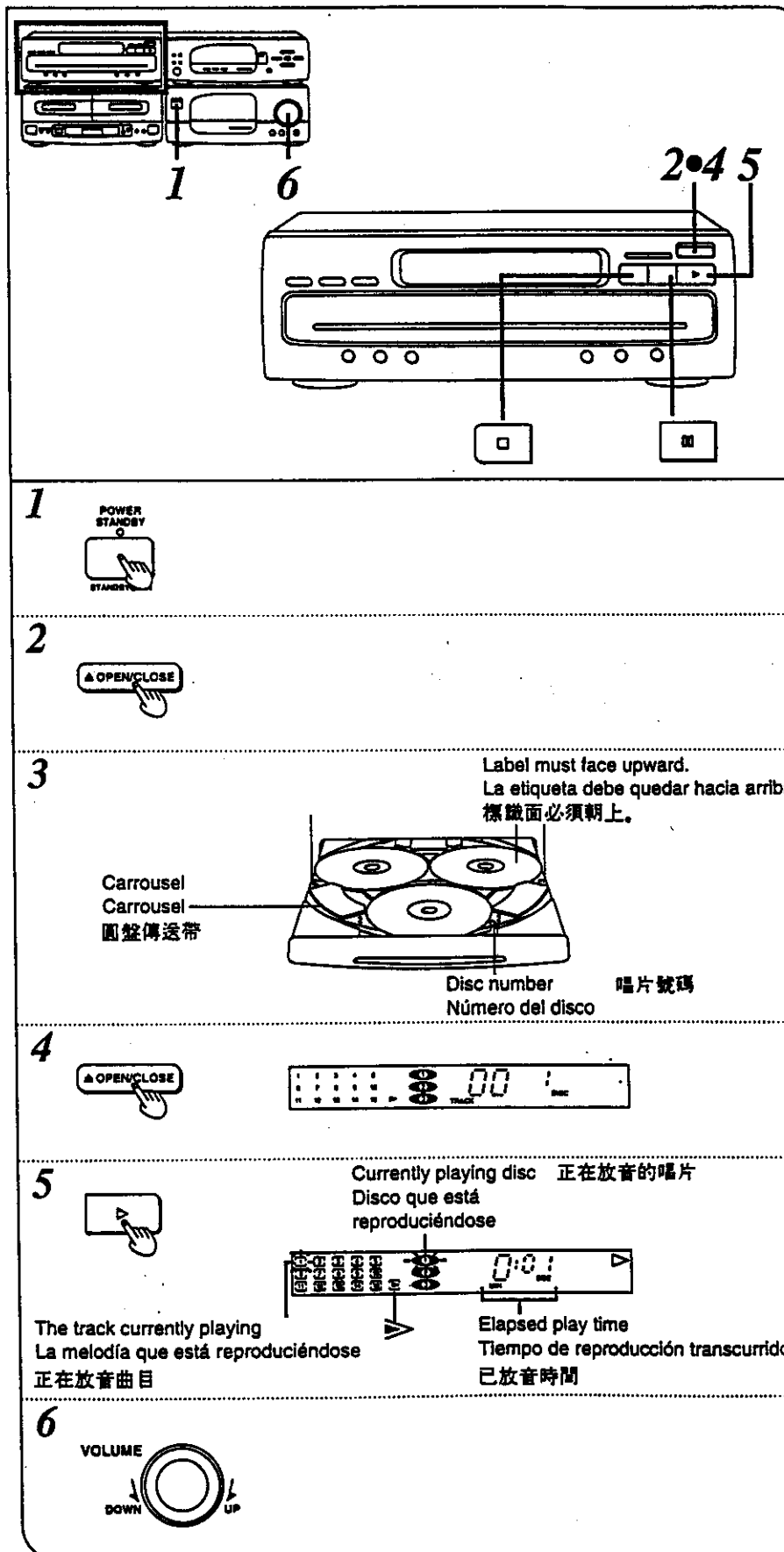

Listening to compact discs

(Continued)

About ▷ indicator:

While halted: Lights in orange.

While playing: Lights in green.

When "▷" appears on the display:

It indicates there are 16 or more tracks on the disc at the playing position.

Concerning the total playing time on the display:

The total playing time displayed includes the silent sections between tracks. Hence, there will be a difference between the total playing time and the liner notes included with the disc.

Notes

- Do not cover the hole or slits. Otherwise the incorrect operation will take place.
- Do not insert another disc onto tray placed at ①, although the tray is partially showing, its disc is in the play position. **4**
- Be sure to load the discs correctly in the center position as shown in the drawing. **5**
- Do not touch the carousel or the loading drawer while it is moving.
- Do not turn the tray forcibly by hand because it may fail to operate normally.
- If the discs are not correctly loaded, play may not start. In such a case, reinsert the disc as following.
 1. Switch the power to the standby mode on the amplifier, and then back on.
 2. Press OPEN/CLOSE to open the loading drawer.
 3. Load the disc(s) on the tray(s) correctly.
- If you press OPEN/CLOSE while the play indicator (▷) is lit in green, the drawer will open to half position. To open fully, follow the procedure below.
 1. Press □.
 2. Press OPEN/CLOSE to close the loading drawer.
 3. Press OPEN/CLOSE again to open the drawer.
- Do not move this changer with a compact disc inside the unit. If a disc comes off the disc tray, it might be scratched or the changer might become incapable of playing.

(To be continued)

A

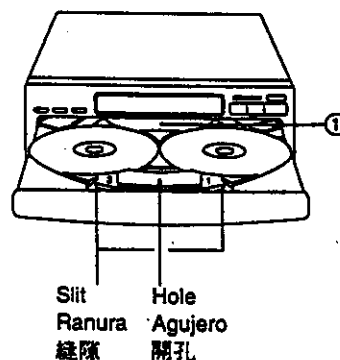

B

8 cm (3") CD
8 釐米 CD (3 英寸)



12 cm (5") CD
12 釐米 CD (5 英寸)

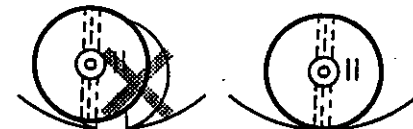

Listening to compact discs

(Continued)

To select the desired disc **A**

Press DISC1, DISC 2 or DISC 3 to select the disc which you want to play.
The play will automatically start from the first track of the disc you select.

To confirm the total playing time of the disc currently playing

Press DISPLAY.
The display will change (as described below) each time you press the button.

In the stop mode: **B**

- ① The display shows the total playing time of the disc at the playing position.
- ② The display shows the disc number and the total track number of the disc currently playing.

In the play mode: **C**

- ① The display shows the track number of the disc at the playing position.
- ② The display shows the elapsed time of the track currently playing.

To exchange discs during play

While a disc is playing, you can exchange discs.

1. Press OPEN/CLOSE during playing.
The loading drawer will open at half position.
2. Exchange the discs.
3. Press OPEN/CLOSE again to close the loading drawer.

After the last track on the current disc finishes playing, the changer will play all the remaining disc(s) loaded, and then stop.

Note

If you play a disc with the loading drawer open, the changer will automatically stop when the last track on the current disc finishes playing.

(To be continued)

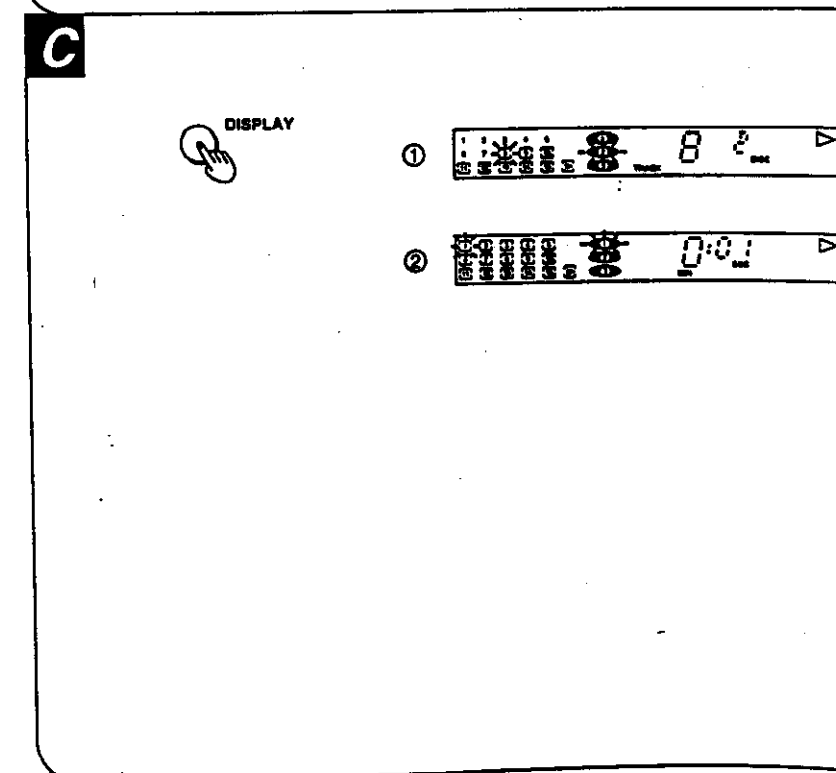
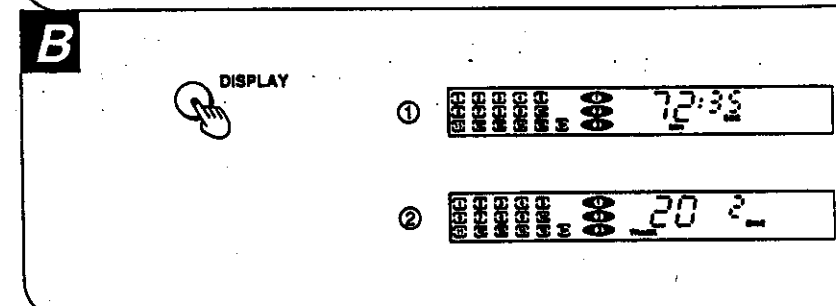
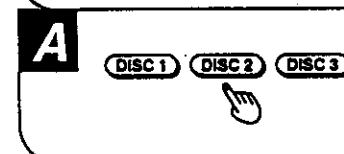
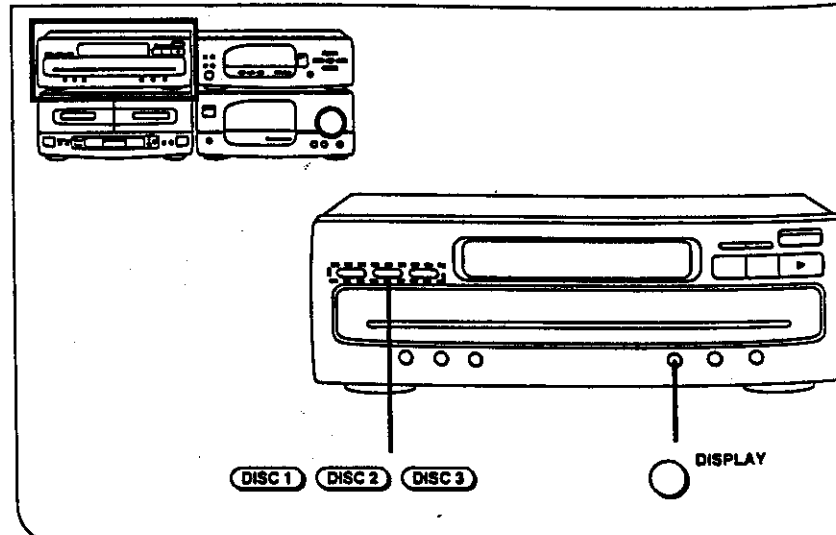

Listening to compact discs

(Continued)

Repeat function

This function repeats the play of all tracks on the loaded discs.

Press REPEAT before or during play.

In sequential play mode:

All tracks of all discs will be played repeatedly.

In program play mode:

The changer plays only the programmed selections in the programmed sequence continuously.

You can enjoy the same track over and over if you press REPEAT when only one track is programmed.

In random play mode:

When the changer has played all tracks on all the loaded discs, it will select a new random sequence and play repeatedly. The sequence differs each time.

To cancel repeat play

Press REPEAT once again.

Indicator on the display will go out.

(To be continued)

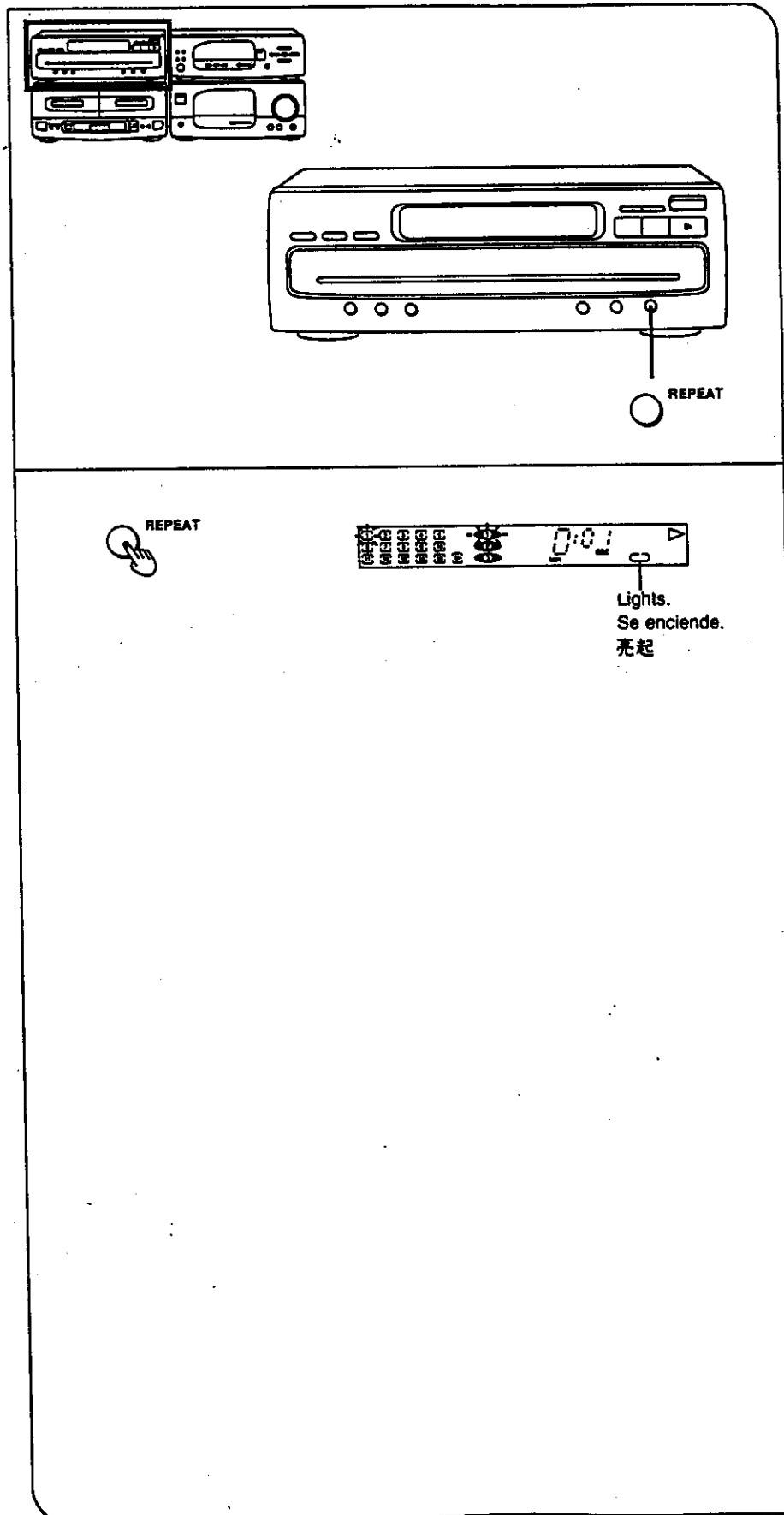

Listening to compact discs

(Continued)

Skip function **A**

Press either **▶▶/▶▶** or **◀◀/◀◀** until you reach the desired track.

▶▶/▶▶ : To skip forward

You can skip as many tracks as the number of time you press the button.

◀◀/◀◀ : To skip backward

You can skip to the beginning of the track being played. If you press this button again quickly, you can skip to the beginning of the previous track.

Note that in a backward skip, the current track is included in the count.

For your reference:

In program play mode you can skip only the programmed tracks.

Note

In random play mode, you cannot skip to the previous track.

Search function **B**

You can rapidly forward or backward on the disc for specific sections.

While in play mode, press and hold either **▶▶/▶▶** or **◀◀/◀◀**. Release the button when you have reached the desired point.

▶▶/▶▶ : To search forward

◀◀/◀◀ : To search backward

For your reference:

During program play and random play, search will take place within the track being played.

(To be continued)

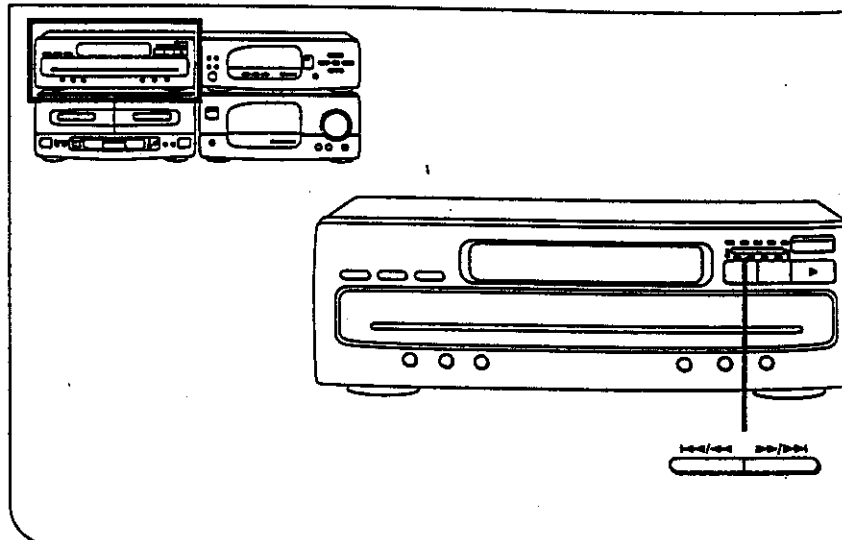

A

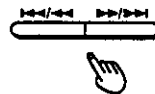

B

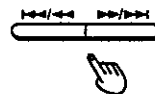

Listening to compact discs

(Continued)

Program play

(Available only from the remote control)

This function allows you to program up to 24 tracks from the loaded disc(s) in any order you choose.

This example shows how to program track 3 of the disc 2, track 5 of the disc 3, track 7 of the disc 1.

- 1 Press CD.
- 2 Press PROGRAM.
- 3 Press DISC.
- 4 Press one of the numeric buttons (1-3) to select the disc.
- 5 Press the numeric button to select the track you want to play.
- 6 Repeat steps 3-5 until you have completed the program.
- 7 Press \triangleright to start play. Play will automatically stop after playing the last track you programmed.

To cancel program play:
Press PROGRAM.

The compact disc changer resumes sequential play mode.

To select a two-digit track:
Press ≥ 10 .

For example:

Track no. 13: $\geq 10 \rightarrow 1 \rightarrow 3$

Track no. 20: $\geq 10 \rightarrow 2 \rightarrow 0$

To add an entry:
Repeat steps 3 to 5.

(To be continued)

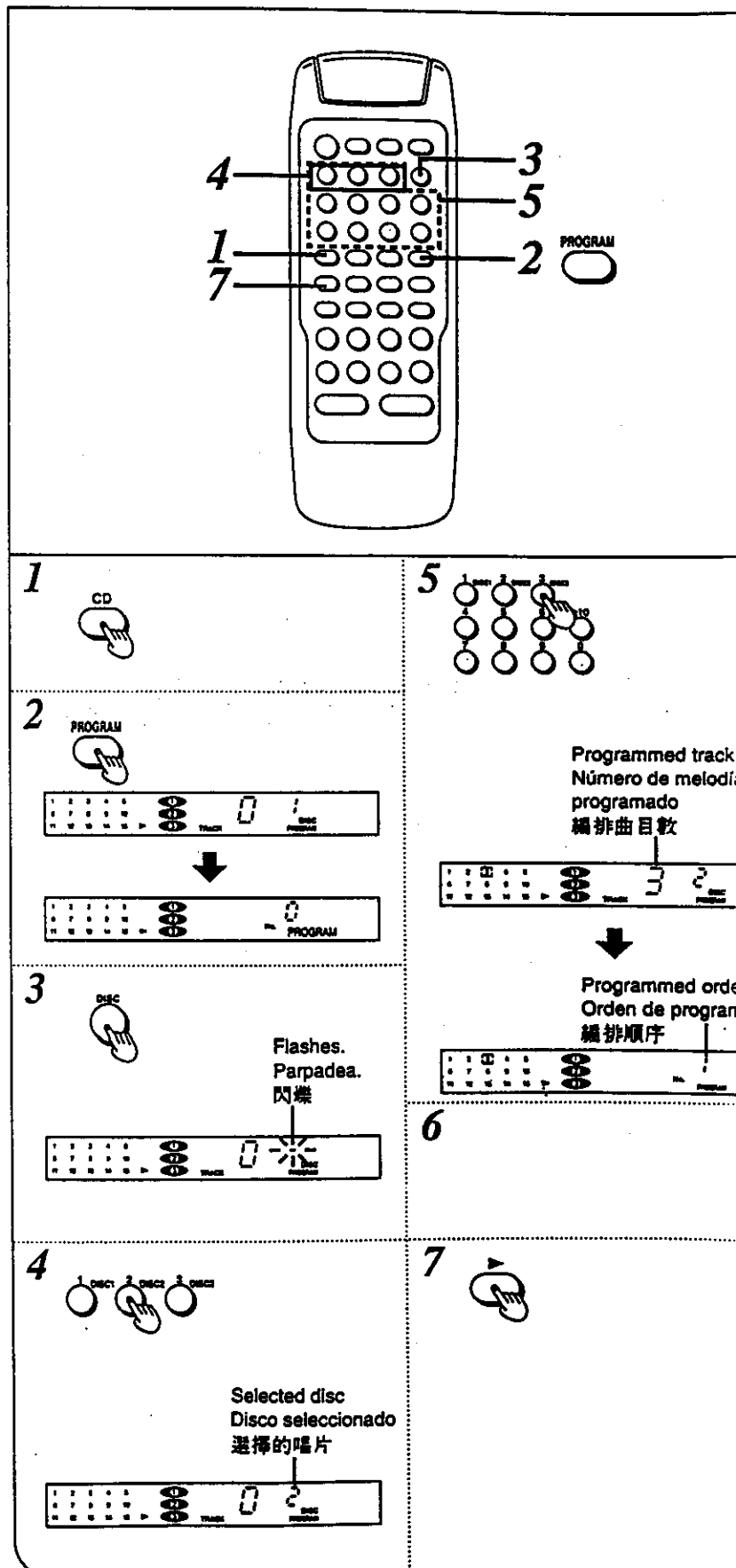

Listening to compact discs

(Continued)

Direct access play

(Available only from the remote control)

Direct access allows you to start sequential play from a specific track on a specific disc and to play all discs loaded in sequence. This example shows how to start the play from the 8th track of the disc 2.

- 1 Press CD.**
- 2 Press DISC.**
- 3 Press one of the numeric buttons (1-3) to specify which disc contains the track you wish to play.**
If you don't proceed to step 4, play will automatically begin with the first track of the selected disc.
- 4 Press the numeric button to select the desired track number.**
Play begins with the track selected and continues to the end of the last disc loaded, and then stops.

To select a two-digit track:
Press ≥ 10 .

For example:

Track no. 13: $\geq 10 \rightarrow 1 \rightarrow 3$

Track no. 20: $\geq 10 \rightarrow 2 \rightarrow 0$

(To be continued)

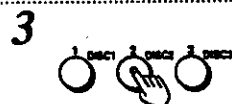
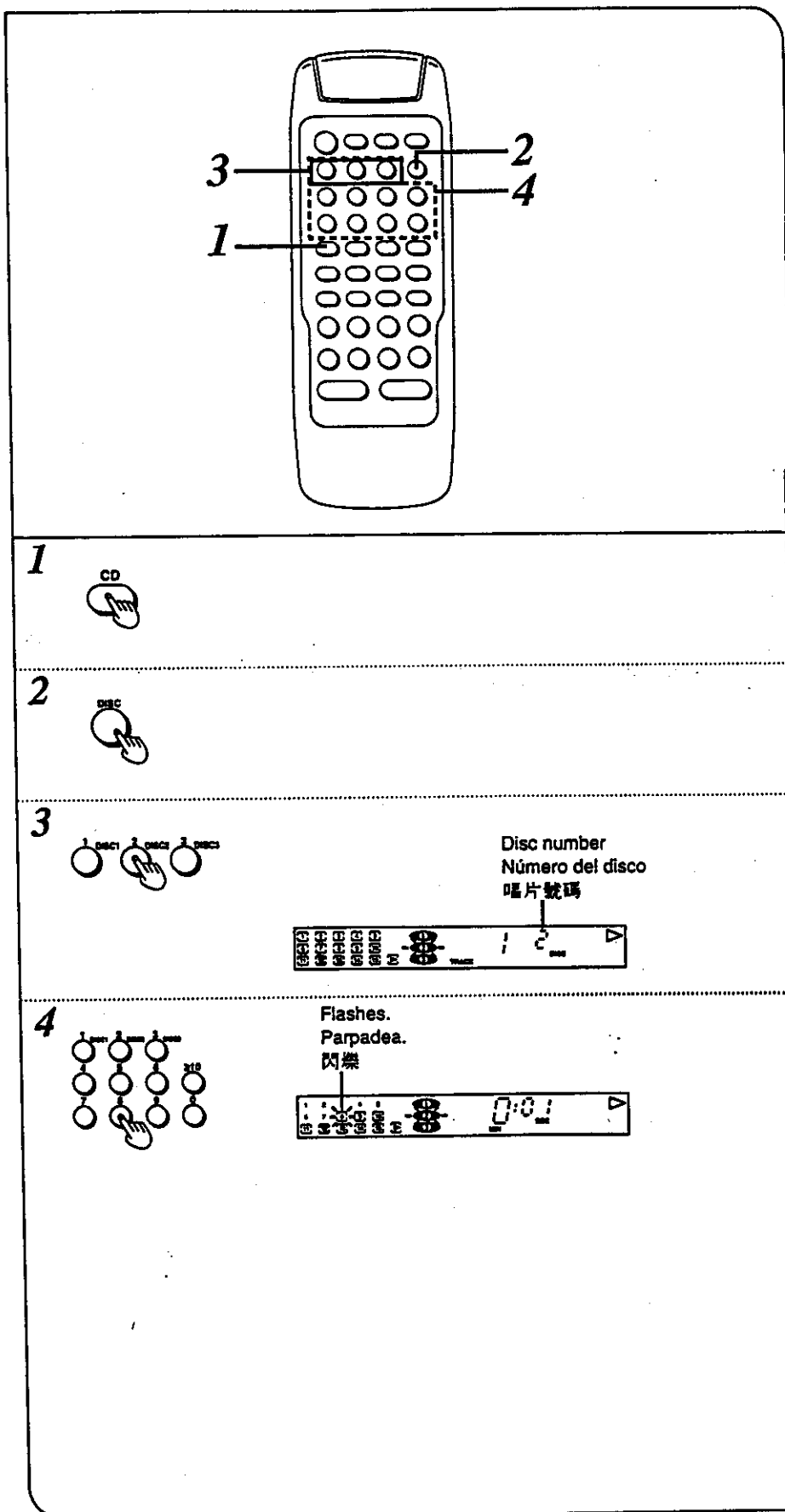

Disc number
Número del disco
唱片號碼

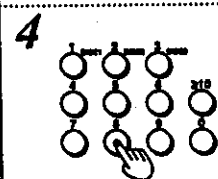

Flashes.
Parpadea.
閃爍

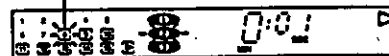

Listening to compact discs

(Continued)

Random play.

The changer will randomly choose a track from a randomly selected disc. Once the changer has played the selected track, it will make another selection at random, excluding the tracks already played. (No tracks will be repeated.)

Press RANDOM.

Random play will start.

The changer will stop automatically when all tracks on all the loaded discs have been played.

To cancel random play:

Press RANDOM once again.

RANDOM indicator will go out. The compact disc changer resumes the sequential play mode.

For your reference:

In the program play mode, the programmed tracks will be played randomly.

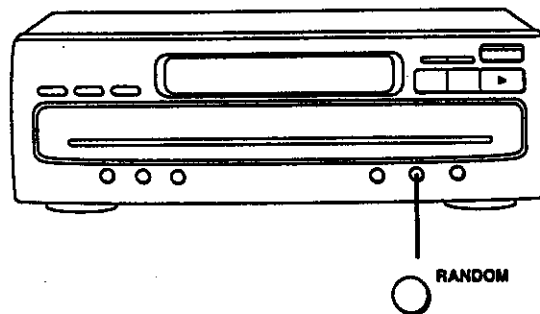
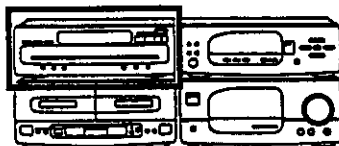

Lights.
Se enciende.
亮起

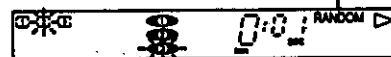

Listening to tapes

Playback

You can use either deck 1 or deck 2 for tape playback. This page shows an example using deck 1.

You can use normal, chrome and metal tapes for playback.

- 1** Switch on the power on the amplifier.
- 2** Press **▲ OPEN**, and then insert the cassette you wish to play. Insert the cassette with the exposed tape facing down.
- 3** Press **CLOSE** on deck 1 to close the cassette holder.
- 4** Press **DOLBY NR** if the cassette you want to play was recorded with Dolby noise reduction B or C mode.
If the tape was not recorded using Dolby NR, press DOLBY NR again so that the Dolby NR indicator (B or C) will go off.

(To be continued)

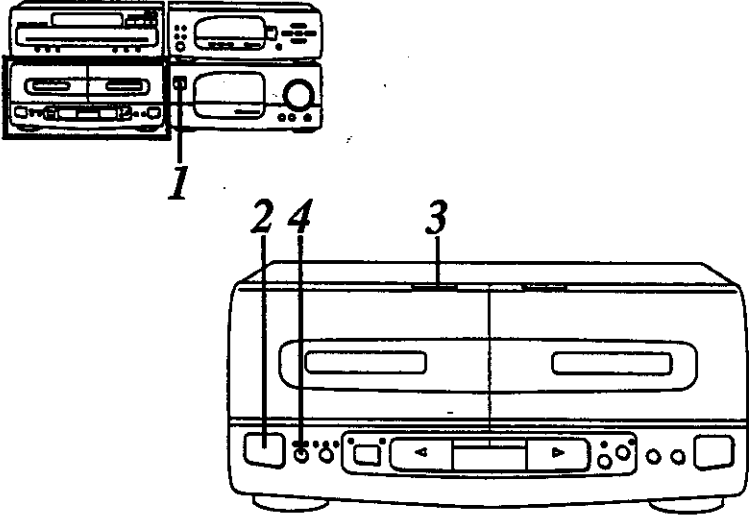

1



2



Front side
Lado delantero
前面



3



Press.
Pulse.
按



4





Listening to tapes

(Continued)

- 5 Press REVERSE MODE to select the reverse mode you want to use.**

Each time you press REVERSE MODE, one of the indicators will light up to show which mode you selected.

-  : The deck plays one side only, and then the tape automatically stops.
-  : The deck plays both sides 8 times, and then the tape automatically stops.
-  : The deck plays both sides of the tape, then automatically stops.

When you load cassettes into both decks, sequential playback will be made. (See page 72.)

- 6 Press ▷ or ◁ to start playback.**
- ▷: The forward side (front side) will play.
 - ◁: The reverse side will play.
- 7 Adjust the volume level as you like on the amplifier.**

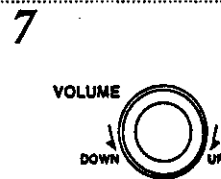
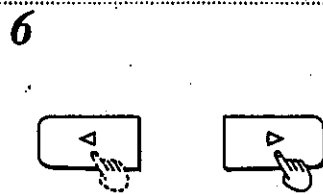
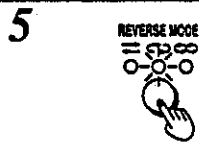
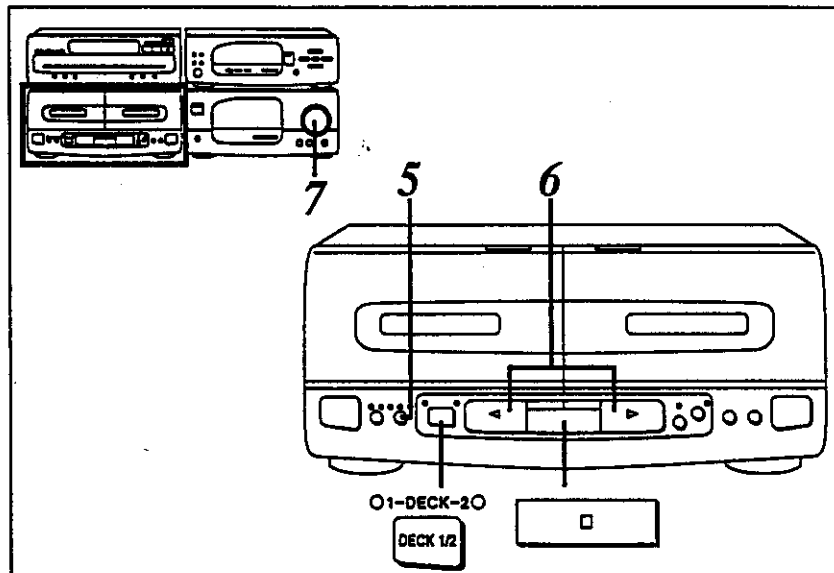

To stop tape playback:
Press □.

To change the deck to be used:
Press DECK 1/2 to select the deck you want to use.
DECK 1 or DECK 2 indicator will illuminate to show which deck you can operate.

For your reference:
The tape will automatically stop when a different sound mode is selected during its operation.

About the ▷ and ◁ Indicators:
While halted, fast forwarding, or rewinding:
Lights in orange.

While playing, recording or finding the beginning of a program:
Lights in green.

(To be continued)



Listening to tapes

(Continued)

To find the beginning of a program (TPS: tape program sensor)

Press (TPS) ►► or ◄◄ (TPS) while the tape is playing.

If the forward side (►) is playing:

◄◄ (TPS) ►► : The tape will play from the beginning of the next tune.

◄◄ (TPS) : The tape will rewind to the beginning of the present tune. Then the tune will play again.

If the reverse side (◄) of the tape is playing:
The reverse operation should take place.

Note

TPS (Tape Program Sensor) is the function that searches for the silent passage in a tape program. So, it may sometimes fail to operate correctly in the following situations:

- When there is no blank space between tape programs (for example, when you are playing a tape recorded from a microphone)
- When the interval between programs (blank space) is less than 4 seconds
- When there is a particular low-level passage or silent passage in the middle of a program (for example, classical music)
- When the program is less than 10 seconds, or when it is less than 10 seconds from the beginning of the program to the beginning of the next program
- When a tape has been recorded with fade-ins (the function that increases the volume level gradually at the beginning of a program) and fade-outs (the function that decreases the volume level gradually at the end of a program)

For your reference:

Each decks' play direction is stored in the system's memory.

(To be continued)

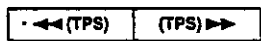
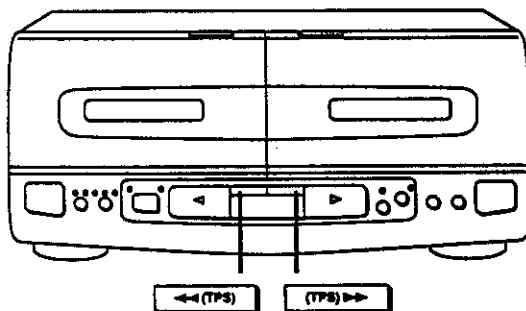
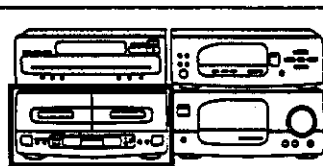

Listening to tapes

(Continued)

To fast forward or rewind the tape **A**

Press (TPS) **▶▶** or **◀◀** (TPS) while the tape is in the stop mode.

If the forward side (▷) of the tape is playing:

▶▶ (TPS) ▶▶ : The tape will be fast forwarded.

◀◀ (TPS) ◀◀ : The tape will be rewind.

If the reverse side (◁) of the tape is playing:
The reverse operation will take place.

High-speed rewind/fast-forward: **B**

On this unit, if there is less tape on the take-up side than on the supply side (refer to the illustration) at the time that **▶▶** or **◀◀** is pressed, the speed of the rewind/fast-forward operation will automatically be increased for approximately 1.5 times the normal speed. This function makes it possible to wind the tape faster when there is a large amount of tape to be wound.

Notes

- When there is more tape on the take up side than on the supply side, the tape will be wound at the normal speed.
- If high speed winding is begun from a state in which the tape is partly wound, such as that shown in the illustration (for example, when the ratio of tape between the two sides is 1:3), high speed winding will continue until the ratio between the two sides reaches 3:1, and then the remaining winding will be done at the normal speed.
- When the winding is begun from either the end or the beginning, all winding will be performed at high speed.

For your reference:

You can fast forward or rewind the tape while you are playing or recording a tape in another deck. Press DECK 1/2 to switch to the non playing deck, and then press **▶▶** or **◀◀**.

After above operation, be sure to press DECK 1/2 to select the deck in which you are playing a tape.

(To be continued)

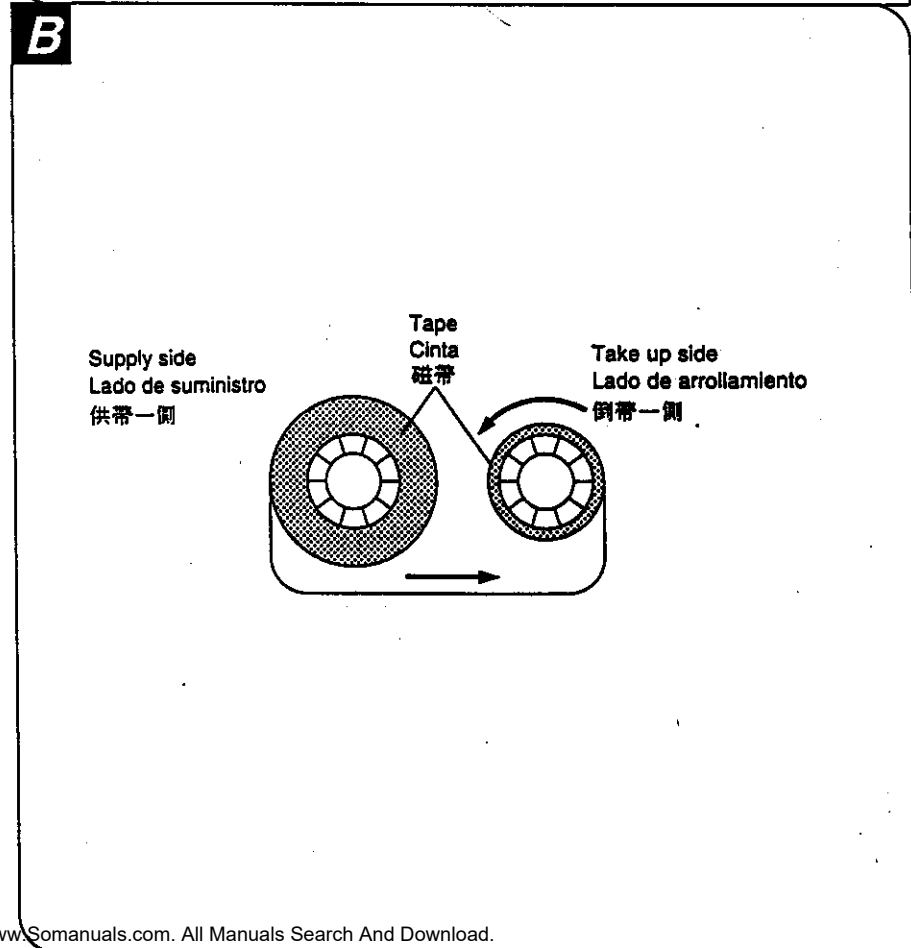
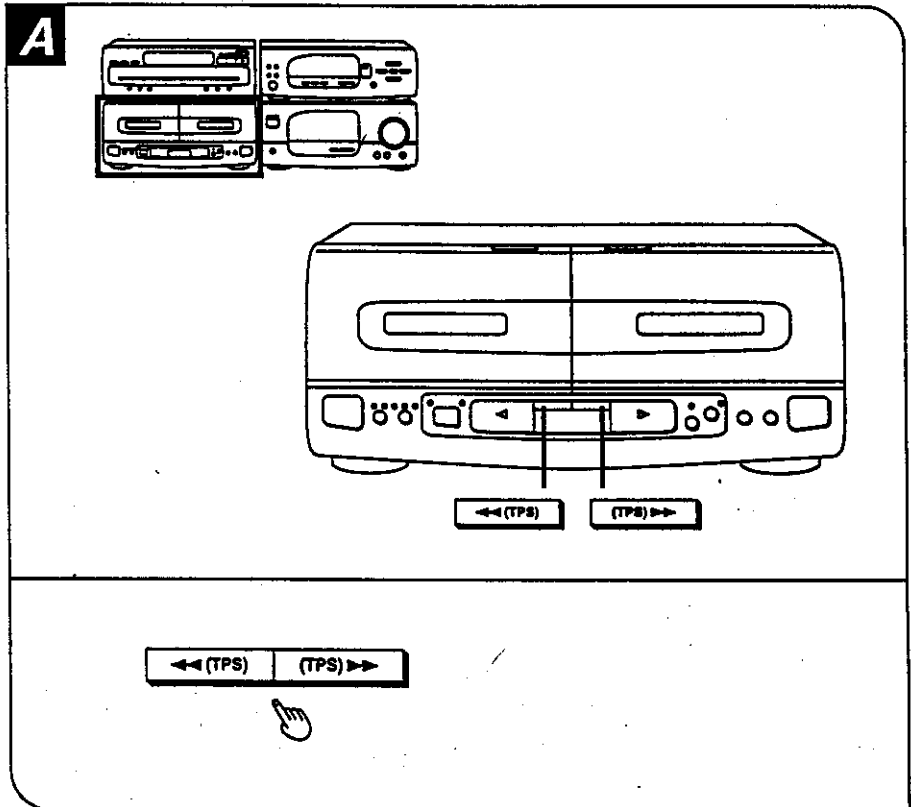



Listening to tapes

(Continued)

Sequential playback between 2 tapes

You can listen to two tapes consecutively with the procedure below.

- 1** Load cassettes in decks 1 and 2. Load with the side that you wish to listen to first facing you in deck 1.
- 2** Press CLOSE to close each deck's cassette holder.
- 3** Press DOLBY NR if the cassette you want to play was recorded with Dolby noise reduction B or C mode.
If the tape was not recorded using Dolby NR, press DOLBY NR again so that the Dolby NR indicator (B or C) will go off.
- 4** Press REVERSE MODE to set to the  mode.
- 5** Press DECK 1/2 to select deck 1. The DECK 1 indicator lights to show you can select deck 1.
- 6** Press  to start playback. Two tapes will play back as described on page 74.

(To be continued)

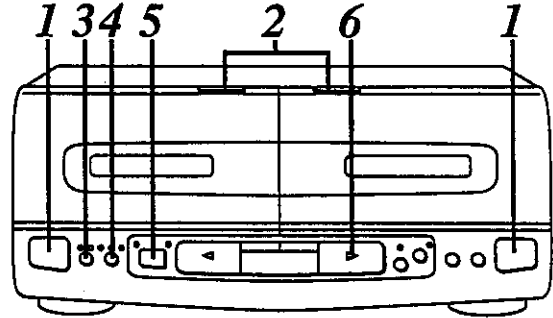
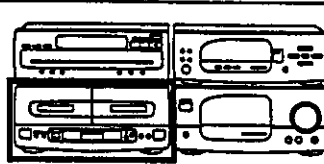

1



2



3



4



5



6



Listening to tapes

(Continued)

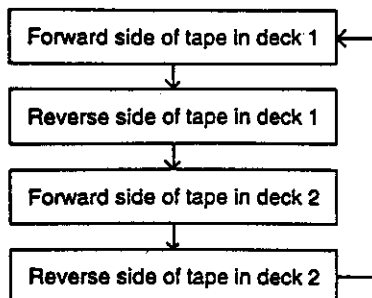

After repeating above operation 8 times, the tape will automatically stop.

To stop sequential tape play: **A**
Press .

For your reference:

- You cannot select Dolby NR for deck 1 and deck 2 respectively. We recommend that you use cassette of the same type (Dolby noise reduction) in both decks.
- You can also start playback from a position other than the forward side of the tape in deck 1.

About priority of the deck:

When you load cassettes in both decks, DECK 1 or 2 indicator will light to show which deck you loaded last.

When you switch on the power, DECK 1 indicator will light.

A

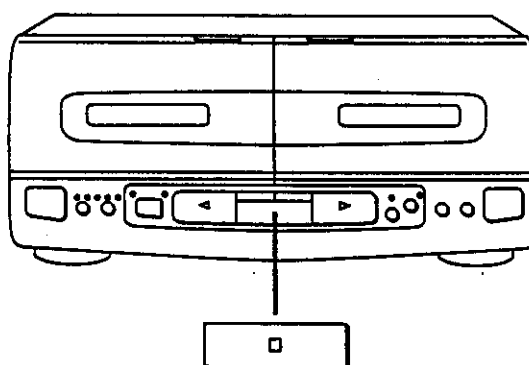
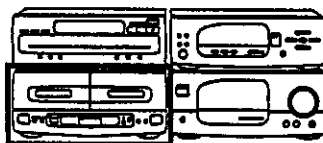

Convenient functions

Easy play

(Available only from the remote control)

From the power standby condition, you can start play directly.

Listening to compact discs **A**

Press **▶**.

The play will start from the first track.

Listening to radio broadcasts **B**

Press **TUNER/BAND**.

You can receive the station last tuned in when the power was switched to standby condition.

Listening to tapes **C**

Press **▶** or **◀**.

- The playback will automatically start corresponding to the direction (**▶** or **◀**) you select.
- Playback will automatically start under the same conditions (reverse mode) as last set when the power was switched to the standby mode.
- When tapes have been loaded in both decks, deck 1 has priority.

About fade-in start in direct play: **D**

When you set the volume level under -60 dB last, the easy play will start with volume increasing to -60 dB gradually (fade-in). When you set the volume level over -58 dB last, the play will start with volume increasing gradually up to the volume level you set last.

(To be continued)

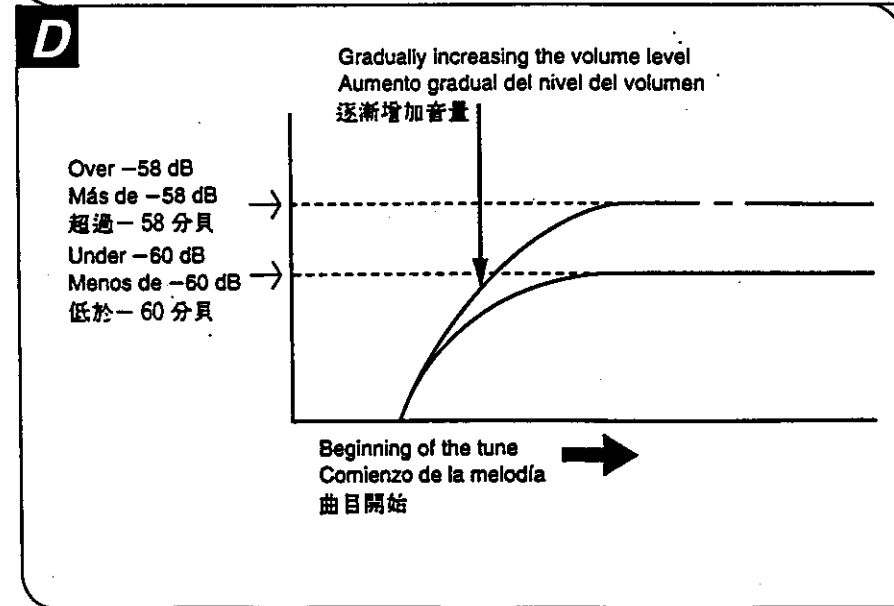
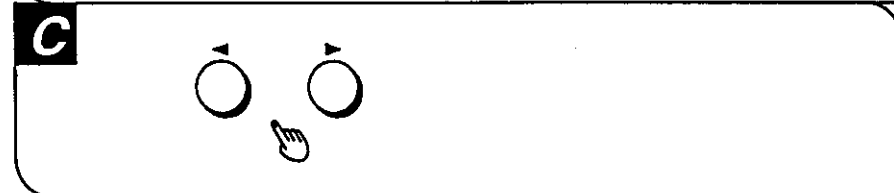
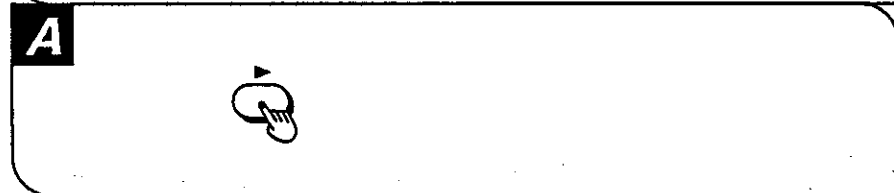
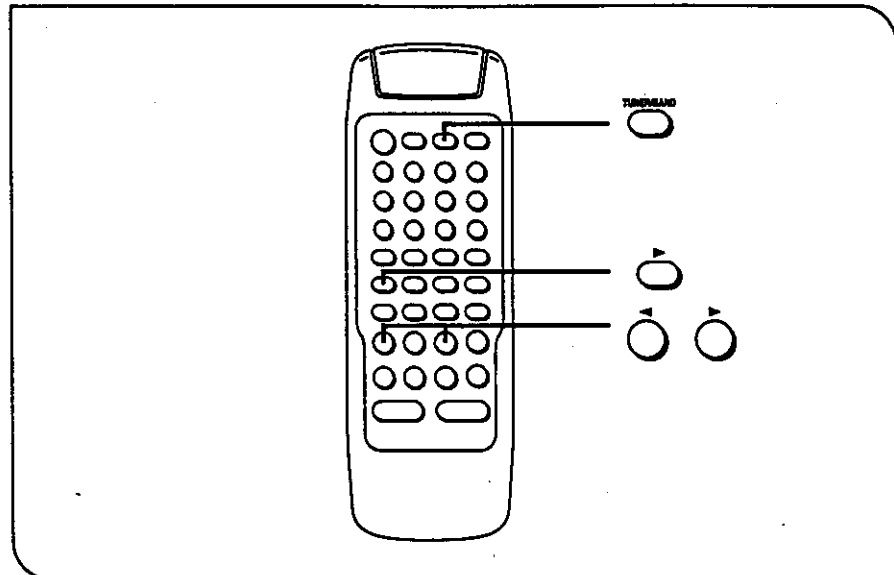

Convenient functions

(Continued)

To mute the volume **A**

(Available only from the remote control)

Press **MUTING -20 dB**.

This feature is convenient when you have a telephone call, etc.

To cancel the muted state, press **MUTING -20 dB** once again.

To cancel from the amplifier, reduce the volume level to the minimum position (**-** dB) and then reset to the desired volume.

To adjust the left-right volume balance **B**

Press one of **BALANCE**.

Perform fine balance adjustment while playing the selected music source. The balance display is only a rough quick.

Pressing **BALANCE** simultaneously will restore the balance to the center position.

To use headphones **C**

Connect the headphones to the headphones jack.

- Before connecting, reduce the volume level.
- Avoid listening for prolonged periods of time to prevent hearing damage.
- Plug type: Stereo mini

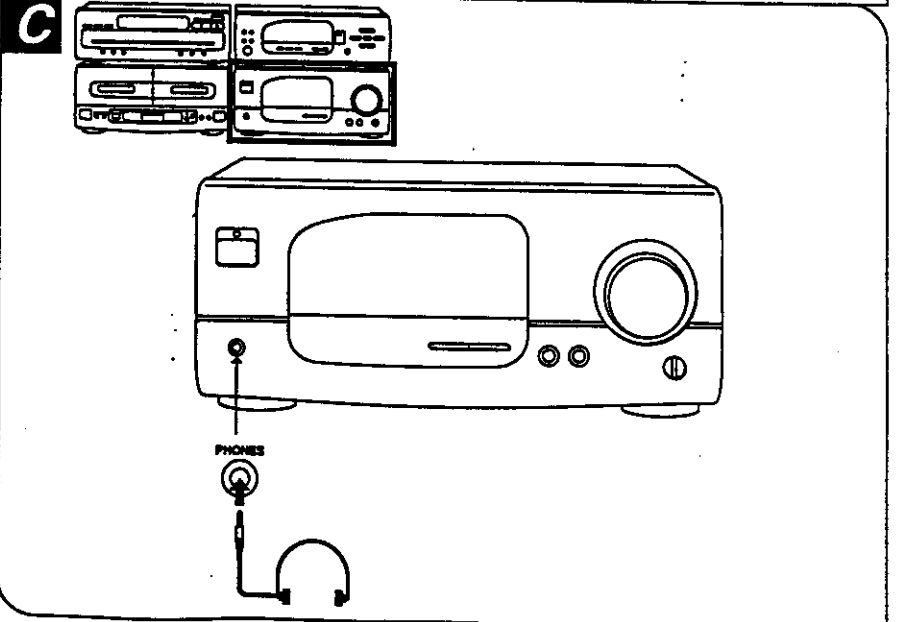
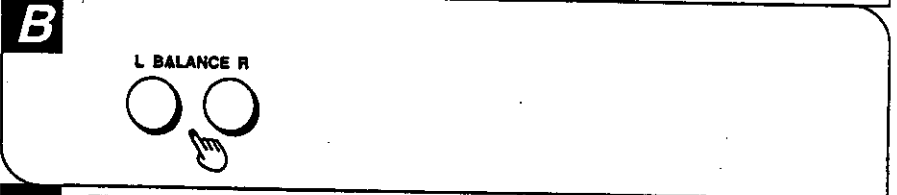
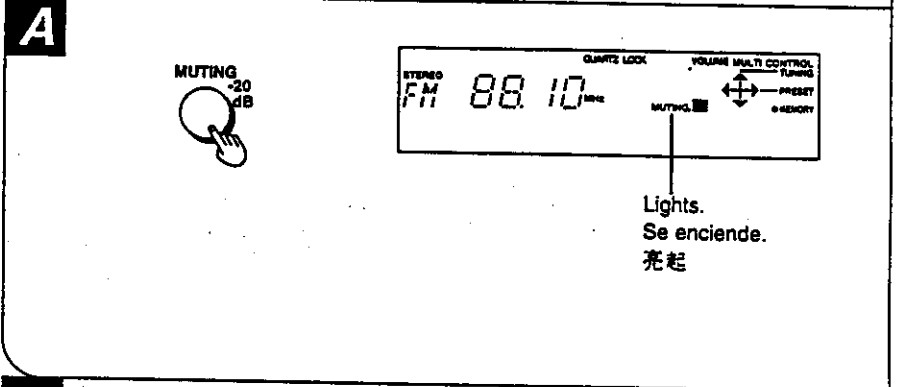
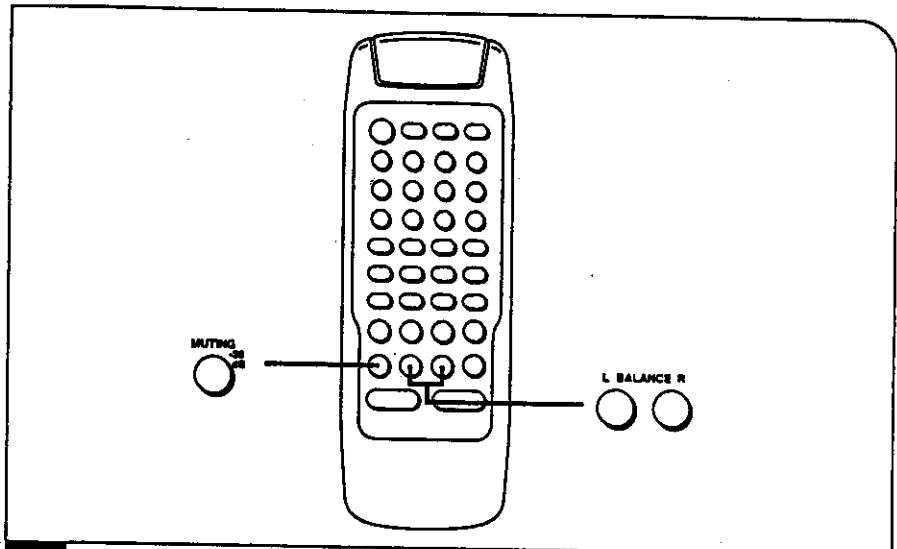

Making a recording from radio broadcasts

You can use normal, chrome, and metal tapes for recording.

Check that the tape's erasure prevention tabs (see page 166) are intact, and then insert the cassette into deck 2.

The leader tape must be wound up beforehand. (See page 84.)

- 1 Press **▲ OPEN** on deck 2 to load a cassette.
- 2 Press **CLOSE** on deck 2 to close the cassette holder.
- 3 Press **DOLBY NR** to select Dolby noise reduction B or C mode. If the tape will not be recorded using Dolby NR, press **DOLBY NR** again so that the Dolby NR indicator (B or C) will go off.

- 4 Press **REVERSE MODE** to select the reverse mode you want to use.

 : One side will record, and then the tape will stop automatically at the tape end.

 : Both sides will record (forward side→reverse side), and then the tape will stop automatically at the tape end.

- 5 Press **CCRT** to activate the CCRT (Computer Control Record Tuning—see page 82) function.

You can record without using the CCRT function.





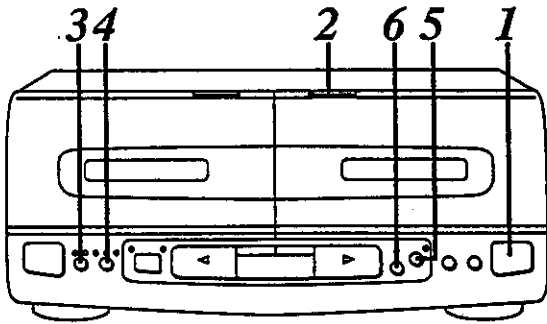

When the CCRT function is activated, the test signal for adjustment will be recorded on the tape, so the previous recording will be automatically erased.

- 6 Press **REC PAUSE** to put the cassette deck into the recording standby mode.

REC PAUSE indicator lights.

(To be continued)



- 1  **OPEN**
- 2  **CLOSE**
- 3  **DOLBY NR**
- 4  **REVERSE MODE**
- 5  **CCRT**
- 6  **REC PAUSE**

FM 88.10 MHz 7 VOLUME MULTI CONTROL TUNING PRESET MEMORY

CCRT

↓

FM 88.10 MHz 7 VOLUME MULTI CONTROL TUNING PRESET MEMORY

SET 0

Making a recording from radio broadcasts

(Continued)

- 7 Press TUNER/BAND, and then ► or ◀ on the tuner/sound processor to tune in to the desired station.
- 8 Press ► or ◀ to start recording.
 - : When recording on either the forward side or both sides
 - ◀: When recording only the reverse side

To stop recording:
Press □.

To cut an unnecessary part while recording:

1. Press REC PAUSE.
The cassette deck will go into the recording standby state.
2. To resume recording, press ► or ◀ corresponding to the direction in which recording is taking place.

CCRT recording function:

CCRT (Computer Control Record Tuning) is the function which identifies the quality of the tape (concerning bias, level, equalizer) automatically and sets the most desirable recording condition. The CCRT indicator flashes while setting, and stops flashing after the setting has completed. The CCRT setting will remain in the system's memory even after the power is switched to the standby mode.

The display shows the CCRT setting conditions as follows: **A**

1. Bias setting
2. Recording level setting
3. Recording equalizer setting

CCRT settings completed:
"SET OK" **B**

- You can make recording in constant tone quality with use of CCRT function regardless of the different characteristics.
- When making an edit-recording from a CD, the CCRT function will be automatically activated.

(To be continued)

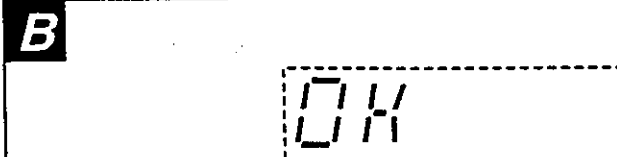
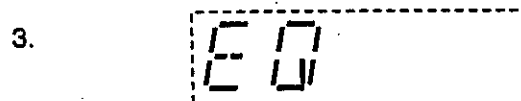
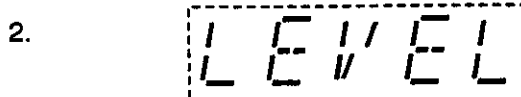
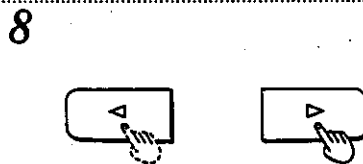
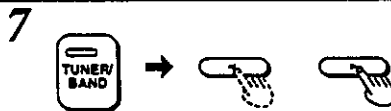
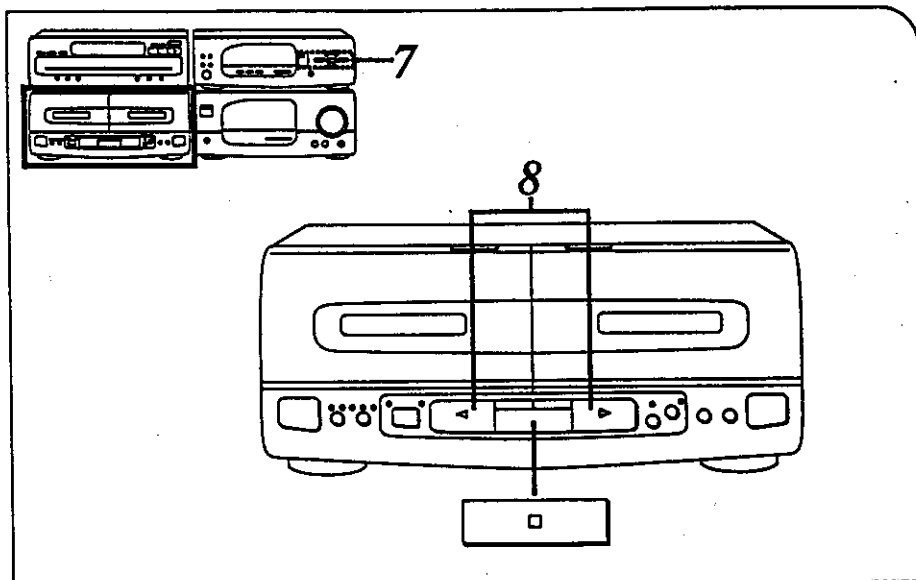

Making a recording from radio broadcasts

(Continued)

Notes

- Do not press INT or EXT while the CCRT setting.
- Do not insert or remove the cassette tape after the CCRT setting has completed. It cancels the CCRT setting.
- The CCRT setting may not be possible with the old cassette tape or at around the end of the cassette tape. (The CCRT indicator starts to flash in a high speed.) In this case, press □ to cancel the CCRT setting (the CCRT indicator goes out).
- Do not connect or disconnect the microphone while recording.

To cancel the CCRT setting on the way:
Press □.

To cancel the CCRT after the CCRT setting has completed:
Press CCRT.

To erase a recorded sound (Deck 2):
When you make a new recording on a previously recorded tape, the new recording will automatically erase what was previously recorded.

To erase a recorded sound without making a new recording, perform the following steps:

- 1) Disconnect the microphone if it was connected.
- 2) Press INT to select the tape mode.
- 3) Press DOLBY NR so that DOLBY NR indicator goes off.
- 4) Insert the recorded tape into the cassette holder of deck 2.
- 5) Select the desired reverse mode.
- 6) Press REC PAUSE.
- 7) Press ▷ or ◁ corresponding to the side to be erased.

To take up the leader tape **A**

The leader tape is the first few revolutions that you cannot record on.

(To be continued)

A

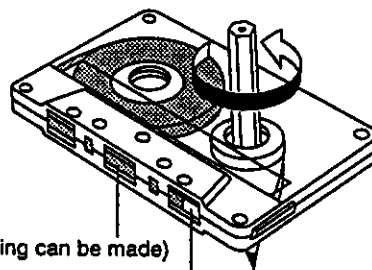

Magnetic tape (recording can be made)
Cinta magnética
(en la que puede grabarse)
磁帶(可以製作錄音)

Leader tape (no recordings can be made)
Cinta guía (en la que no puede grabarse)
引帶(不能製作錄音)

Making a recording from radio broadcasts

(Continued)

To record with desired tone quality

To record with the desired tone quality, follow the procedure below.

1. Select the desired tone quality. (See pages 114, 116, 118, 120, 122 and 124.)
2. Follow the procedure of "Making a recording from the radio broadcasts" on pages 80 and 82.

Note

When playing back such recordings, press ON/FLAT on the tuner/sound processor section to set to "FLAT".

To record without any tonal effect

Press ON/FLAT on the tuner/sound processor to set to "FLAT".
(See pages 116 and 120.)

About Dolby Noise Reduction system

Using Dolby NR reduces tape hiss in the high-frequency range. It boosts the level of the high-frequency during recording, and lowers it by the same amount during playback, simultaneously reducing high-frequency interference incurred during the recording process.

Dolby B NR type:

Noise is reduced to about $\frac{1}{3}$. Use this type when playing a tape in Dolby NR.

Dolby C NR type:

Noise is reduced to about $\frac{1}{10}$. Use this type when recording and playing back a high quality, high dynamic range source such as a CD or FM broadcast.

Dolby noise reduction manufactured under license from Dolby Laboratories Licensing Corporation.
"DOLBY" and the double-D symbol  are trademarks of Dolby Laboratories Licensing Corporation.

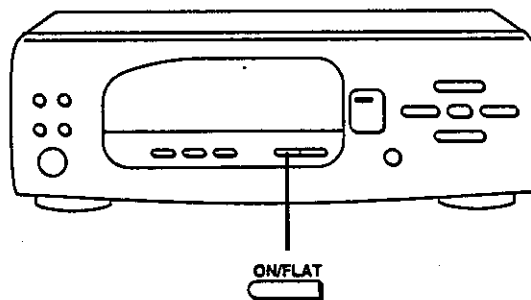
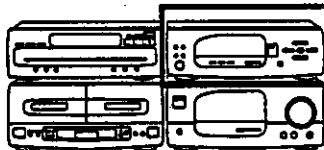

Recording from compact discs

There are 2 ways to record from compact discs, one-touch editing and synchro-recording. See below for the information.

One-touch editing

The system calculates the length of the tape used, and safeguards against a break in the continuity of sound when the recording changes from one side of the tape to the other. (Except for LAST FADE mode)

Editing of all tracks in their original sequence (ALBUM): **[A]**

If the system determines it is possible to record one more track on side A, the cassette deck rewinds the tape side A and the first track assigned on the tape side B will be recorded on the tape side A. Up to 24 tracks can be edited.

Allotting tracks to the tape without wasting tape space (J. FIT): **[B]**

If the amount of blank space is too great, the cassette deck rewind the tape end and the compact disc changer selects a track which is the most appropriate fit for the end of tape side A. Up to 24 tracks can be edited.

(To be continued)

A

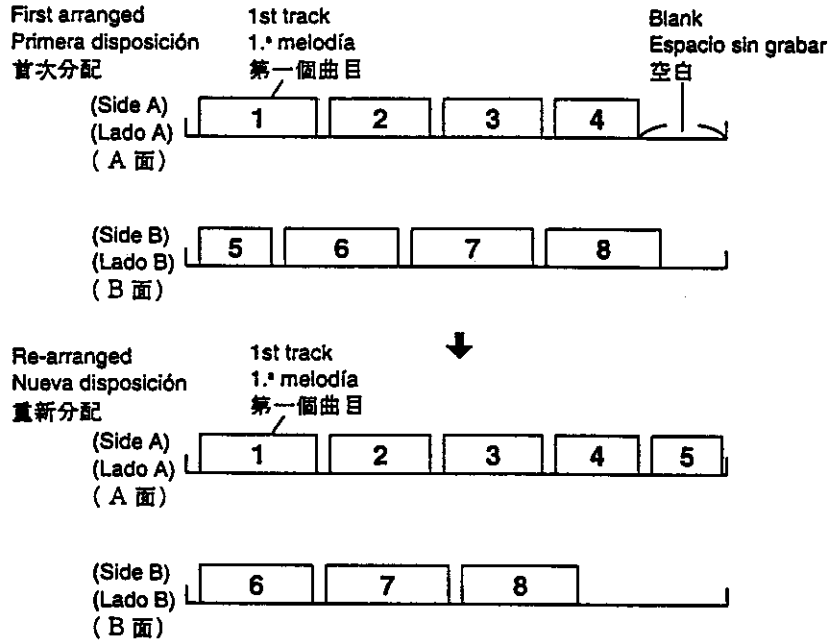

B

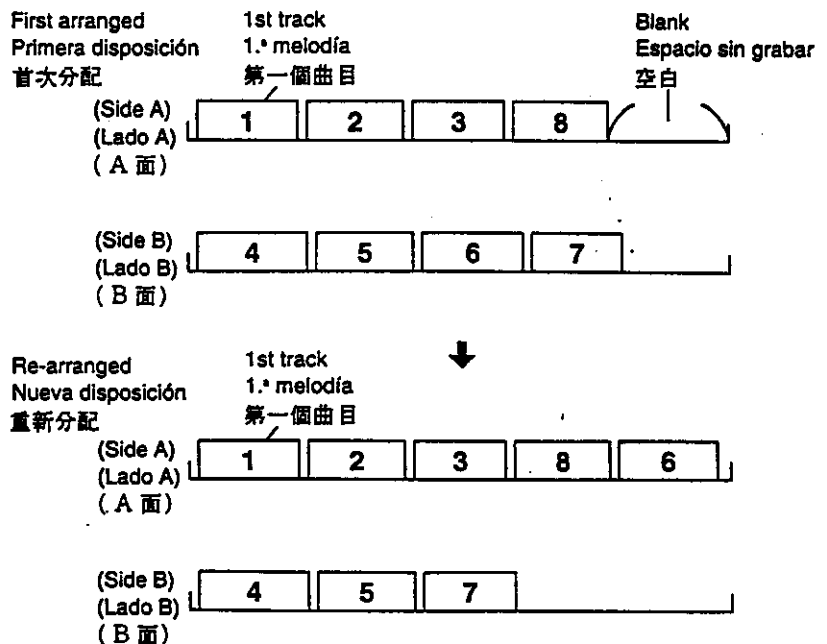

Recording from compact discs

(Continued)

Closing up the tape-end unrecorded sections (LAST FADE): **A**

At the end of side A of the tape, a track that cannot be recorded completely will be faded out, and then recorded from the beginning of side "B". During recording, silent gaps of approximately 4 seconds are automatically inserted between tracks (auto space function).

You can edit as many tracks as you like using this mode.

You can edit the desired tracks of the desired discs using the program play procedure. (See "Program edit-recording" on page 98.)

Linking up several discs (LINK): **B**

This example shows when you use J. FIT edit.

After the edit-recording of loaded disc(s) has finished, you can subsequently edit-record another disc on the remaining blank portion of the tape.

This function is convenient when recording from 8 cm (3") compact discs successively.

Synchro-recording

The system records tracks in the original sequence without calculating the tape length.

You can record as many tracks as you like using this mode.

When you want to record on the remaining portion of the pre-recorded tape, use the synchro-recording.

(To be continued)

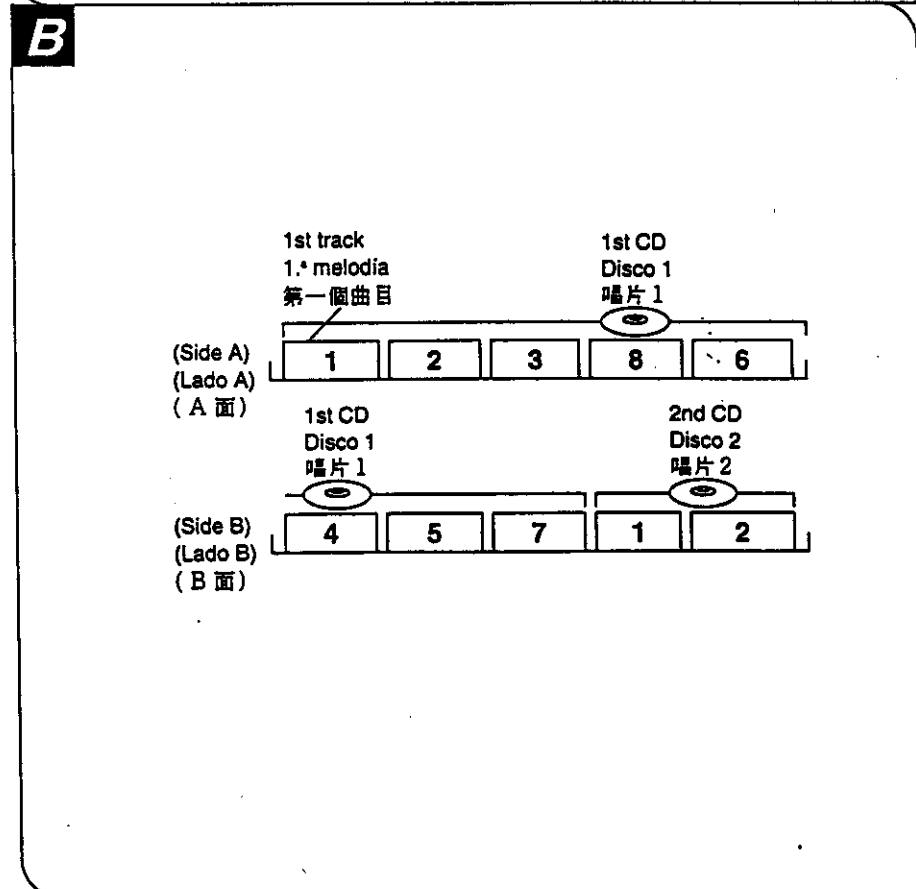
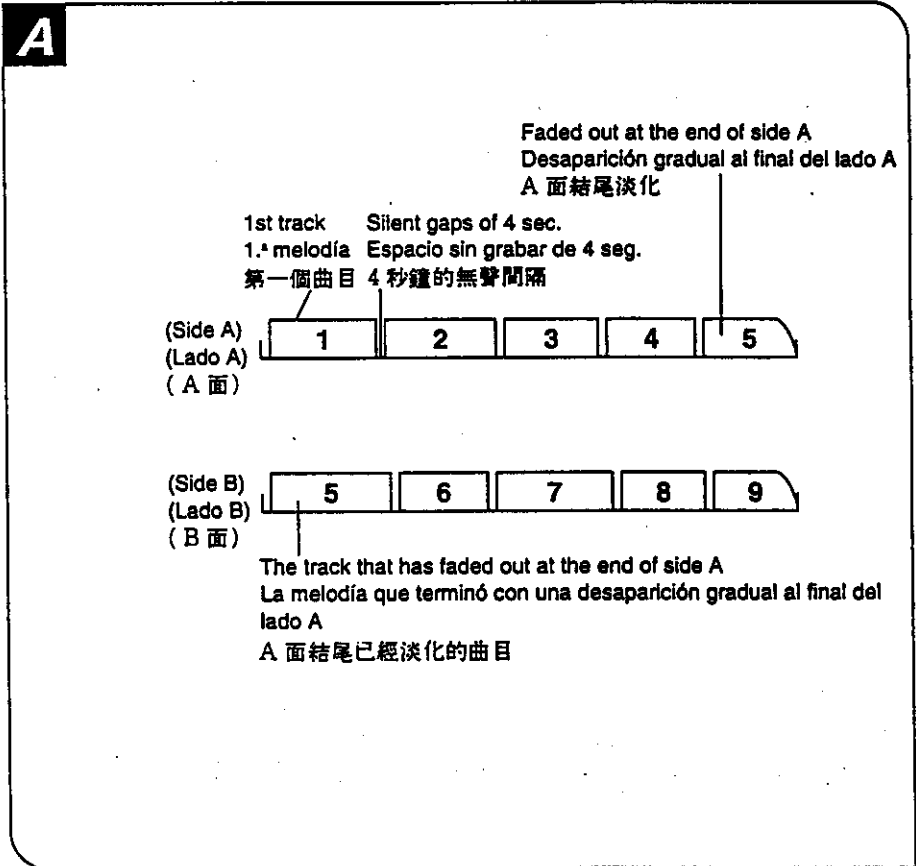

Recording from compact discs

(Continued)

One-touch editing preparation **A**

You can use normal, chrome, and metal tapes for recording. Check that the tape's erasure prevention tabs (see page 166) are intact, and then insert the cassette into deck 2.

- 1** Press **▲ OPEN** to load a cassette in deck 2.
When the edit-record starts, the cassette deck will automatically rewind the tape back to the beginning where the recording can be made. So you don't have to rewind the tape in advance.
- 2** Press **CLOSE** on deck 2 to close the cassette holder.
- 3** Press **DOLBY NR** to select Dolby noise reduction B or C mode.
If the tape will not be recorded using Dolby NR, press DOLBY NR again so that the Dolby NR indicator (B or C) will go off.
- 4** Press **REVERSE MODE** to select "⏮" for automatic two-sided recording.
- 5** Press **▲ OPEN/CLOSE** on the compact disc changer to load a disc, and then press it again.

To start one-touch editing

There are 3 types of one-touch editing.

Be sure to finish the procedure of "One-touch editing preparation" above.

Editing of all tracks in their original sequence (ALBUM) **B**

Press **ALBUM**.

The recording will start after the system completes the "One-touch editing operation" on page 96.

Notes

- Use a tape of under 99 minutes.
- You cannot edit-record tracks numbering higher than 24.

(To be continued)

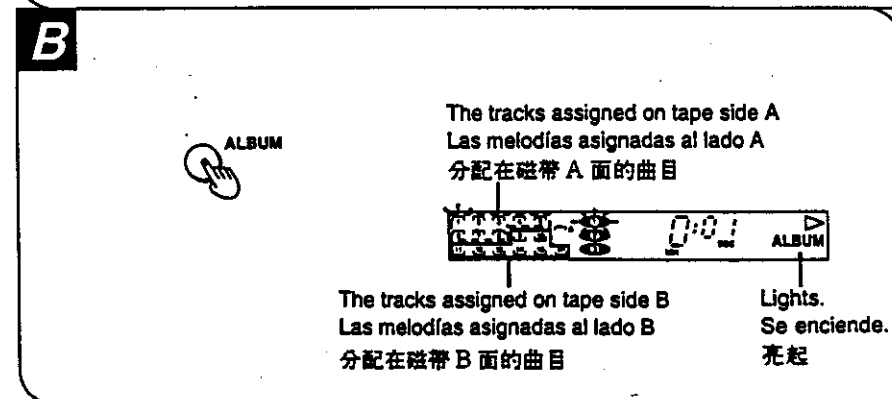
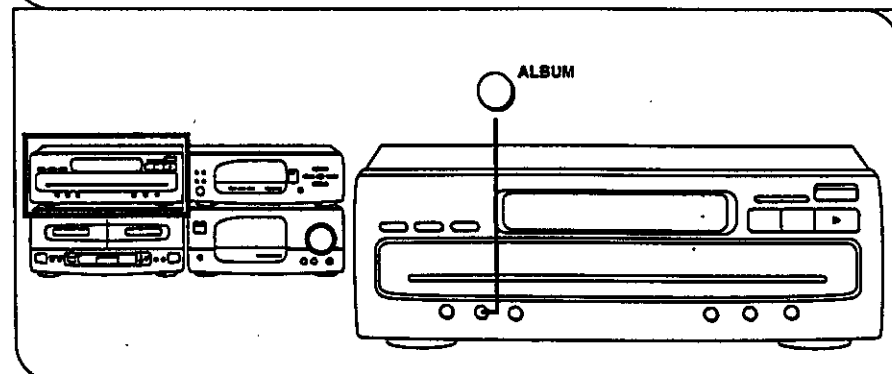
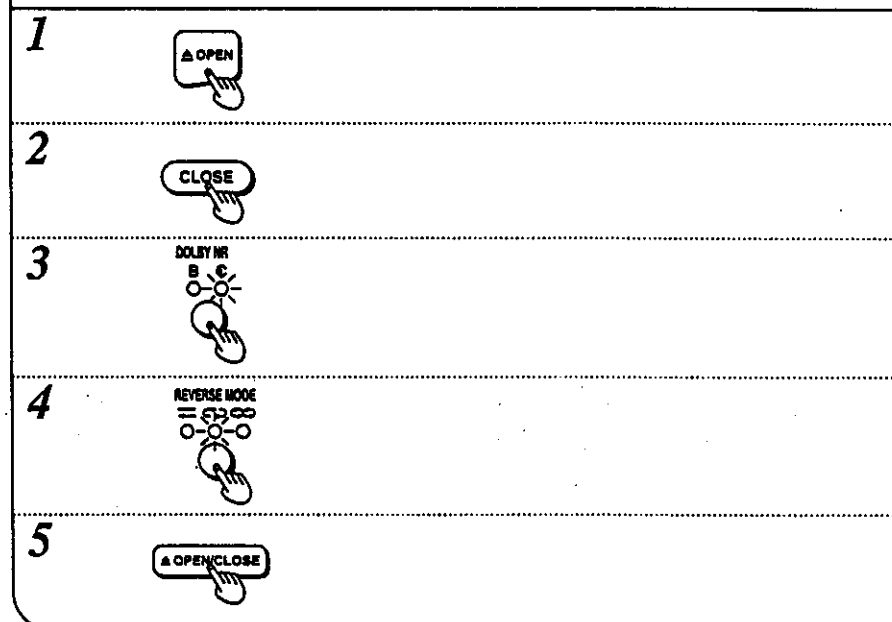
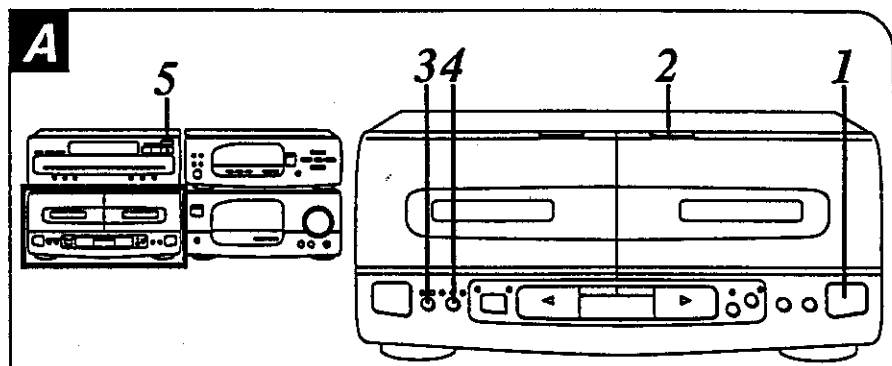

Recording from compact discs

(Continued)

Allotting tracks to the tape without wasting tape space (J. FIT) **A**

Press J. FIT.

The recording will start after the system completes the "One-touch editing operation" on page 96.

Notes

- Use a tape of under 99 minutes.
- You cannot edit-record tracks numbering higher than 24.

Closing up the tape-end unrecorded sections (LAST FADE) **B**

Press LAST FADE.

The recording will start after the system completes steps 2-3 of "One-touch editing operation" on page 96.

- Use this editing mode when you record more than 24 tracks.
- You can edit the desired tracks of the desired disc(s) using this editing mode. (See "Program edit recording" on page 98.)

To cancel one-touch editing:

Press \square on the cassette deck.

The compact disc changer also stops.

(To be continued)

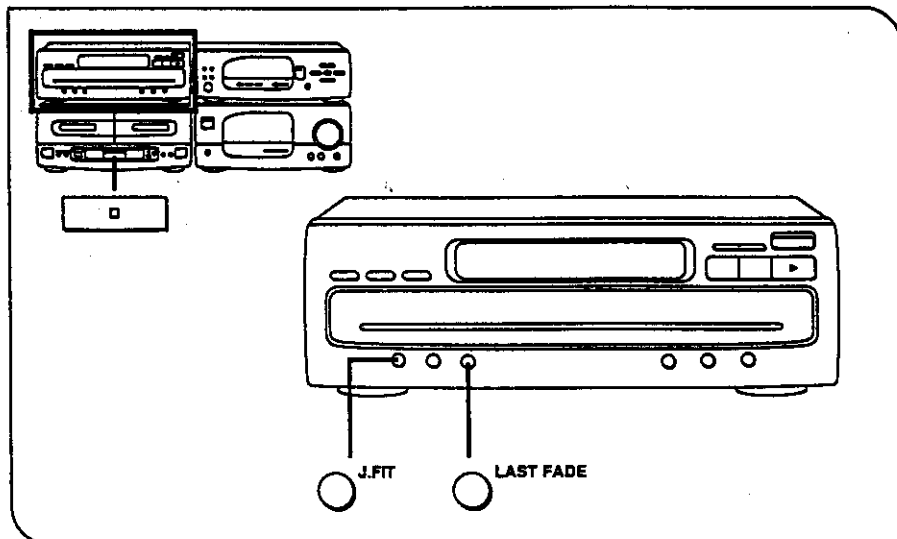

A



The tracks assigned on tape side A
Las melodías asignadas al lado A
分配在磁帶 A 面的曲目

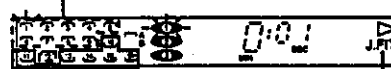

The tracks assigned on tape side B
Las melodías asignadas al lado B
分配在磁帶 B 面的曲目

Lights.
Se enciende.
亮起

B



Lights.
Se enciende.
亮起

Recording from compact discs

(Continued)

One-touch editing operation:

1. The cassette deck will fast-forward and rewind to measure its length. At the same time, CCRT function will be activated. (See page 82.)
2. The cassette deck will automatically advance the tape beyond the leader tape, and then stop.
3. The compact disc changer automatically scans for the peak (highest) level of the entire disc (Automatic Tape Level Setting—ATLS), then recording will start. ATLS is the function which scans (fast search) for the peak (highest) level of the disc, and sets the appropriate recording level. When ATLS is activated, no sound will be heard.

It takes about 70 seconds to complete ATLS for a compact disc of 60 minutes.

When there are tracks allotted on tape side B:

After recording tracks allotted on tape side A, the cassette deck will continue recording making the blank portion on tape side A to measure the tape length.

To record with desired tone quality:

A

Select the desired tone quality (see pages 114, 116, 118, 120, 122 and 124), and start editing. To play back such recordings, press ON/FLAT on the tuner/sound processor to set to FLAT.

After the edit recording has finished:

When one disc is loaded:

The deck automatically enters the recording standby mode. When "LINK" indicator flashes, it means you can edit tracks from same or another disc in succession.

(See page 100.)

When two or three discs are loaded:

When there is a blank portion on the tape, the deck will automatically start edit-recording from the next compact disc.

When "LINK" indicator flashes after recording of all the loaded discs has finished, it means you can edit tracks from the same or another disc(s) in succession.

To finish recording:

Press on the compact disc changer and "LINK" indicator goes off.

(To be continued)

A

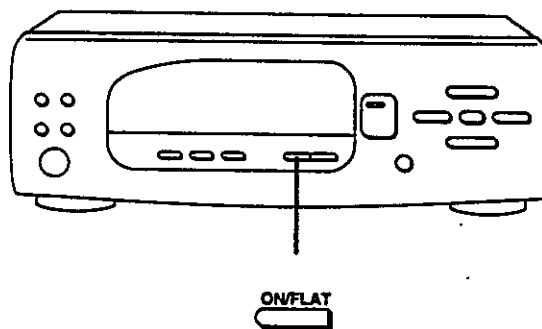
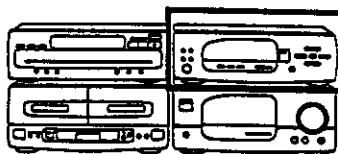

Recording from compact discs

(Continued)

Program edit-recording (LAST FADE mode only)

You can record the desired tracks of the desired disc(s) on the loading drawer using LAST FADE mode.

The cassette deck will automatically rewind the tape back to the beginning where the recording can be made. So you don't have to rewind the tape in advance.

- 1 Follow steps 1-4 on page 92.
- 2 Press \blacktriangle OPEN/CLOSE to load disc(s) and then press it again.
- 3 Press PROGRAM.
- 4 Press DISC.
- 5 Press one of the disc buttons (DISC 1-3) to select disc number.
- 6 Press the numeric button to select the track you want to record.
- 7 Repeat steps 4-6 to complete the program.
- 8 Press LAST FADE.
The recording will start after the system completes steps 2-3 of "One-touch editing operation" on page 96.

To stop recording:
Press \square on the cassette deck.

After the compact disc play finishes:
The cassette deck will create a non-recorded passage of about 4 seconds, and then go into the recording standby state.

When "F" appears on the display:
The number of programmed tracks is limited to 24. No further tracks can be programmed.

(To be continued)

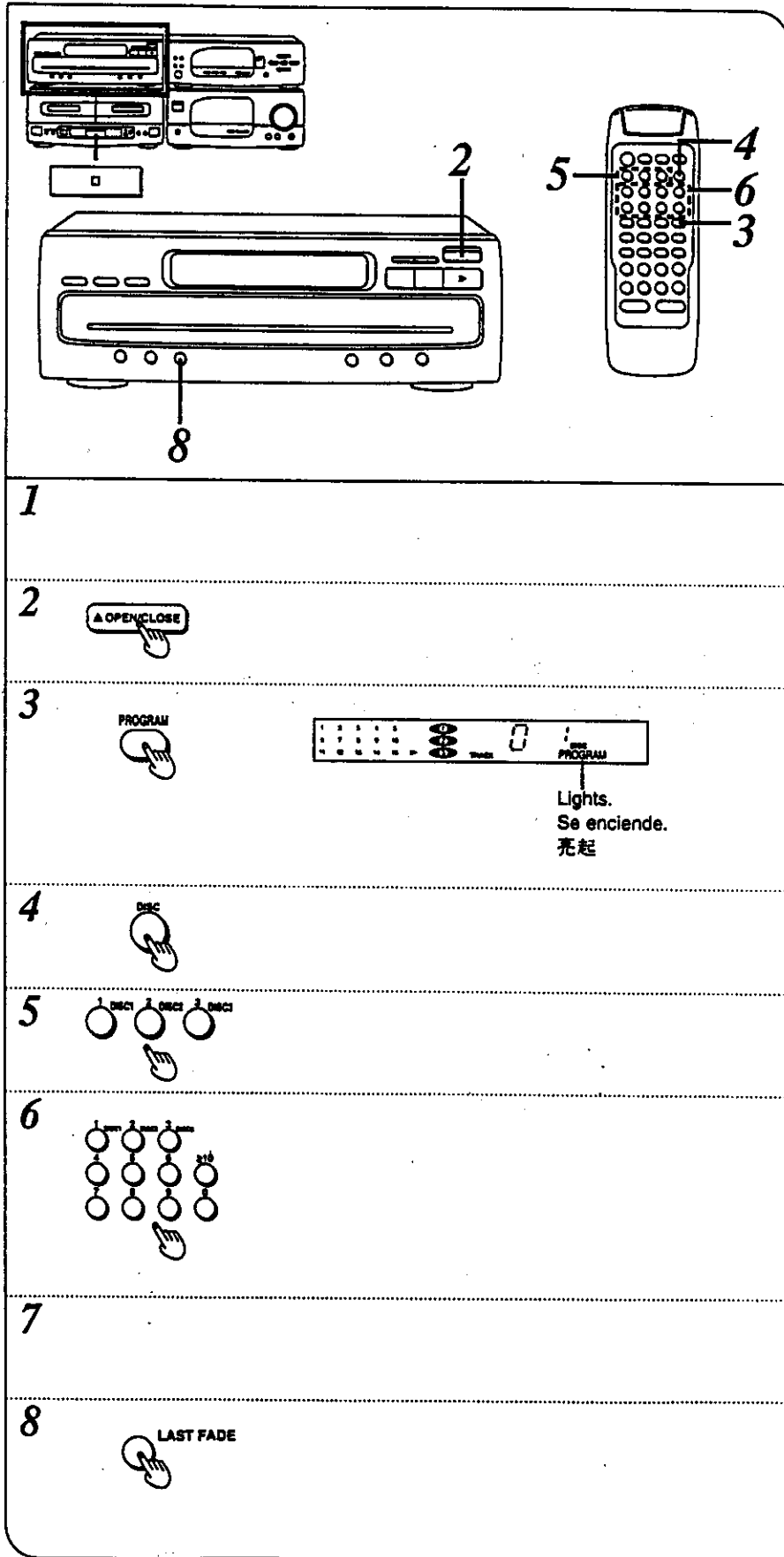

Recording from compact discs

(Continued)

Linking up several discs (LINK)

When "LINK" indicator flashes after the edit-recording of loaded disc(s) has finished, you can subsequently edit-record the same or another disc(s) on the remaining blank portion of the tape.

Finish the first edit-recording of the loaded disc(s).

- 1 Press **▲ OPEN/CLOSE** to replace disc(s) and press it again.
- 2 Press **▷**.
The recording will start from the disc on the disc tray 1, with the same editing mode of the first disc.
The system will assign tracks to be recorded on the remainder of the tape and display the results.
The recording will start after the system completes the ATLS (see "One-touch editing operation" on page 96) setting.
- 3 Repeat steps 1-2 to record more discs.

To cancel the LINK function:
Press **□**.

To specify the tracks to be edited:
(Steps 2-5 are available only from the remote control.)

1. Replace the CD.
2. Press PROGRAM.
3. Press DISC.
4. Press one of the numeric buttons (1-3) to select disc number.
5. Press numeric buttons to specify the tracks you want to record.
6. Press **▷** to start recording.

To record from the same disc(s) in succession:
Follow steps 2-6 above.

(To be continued)

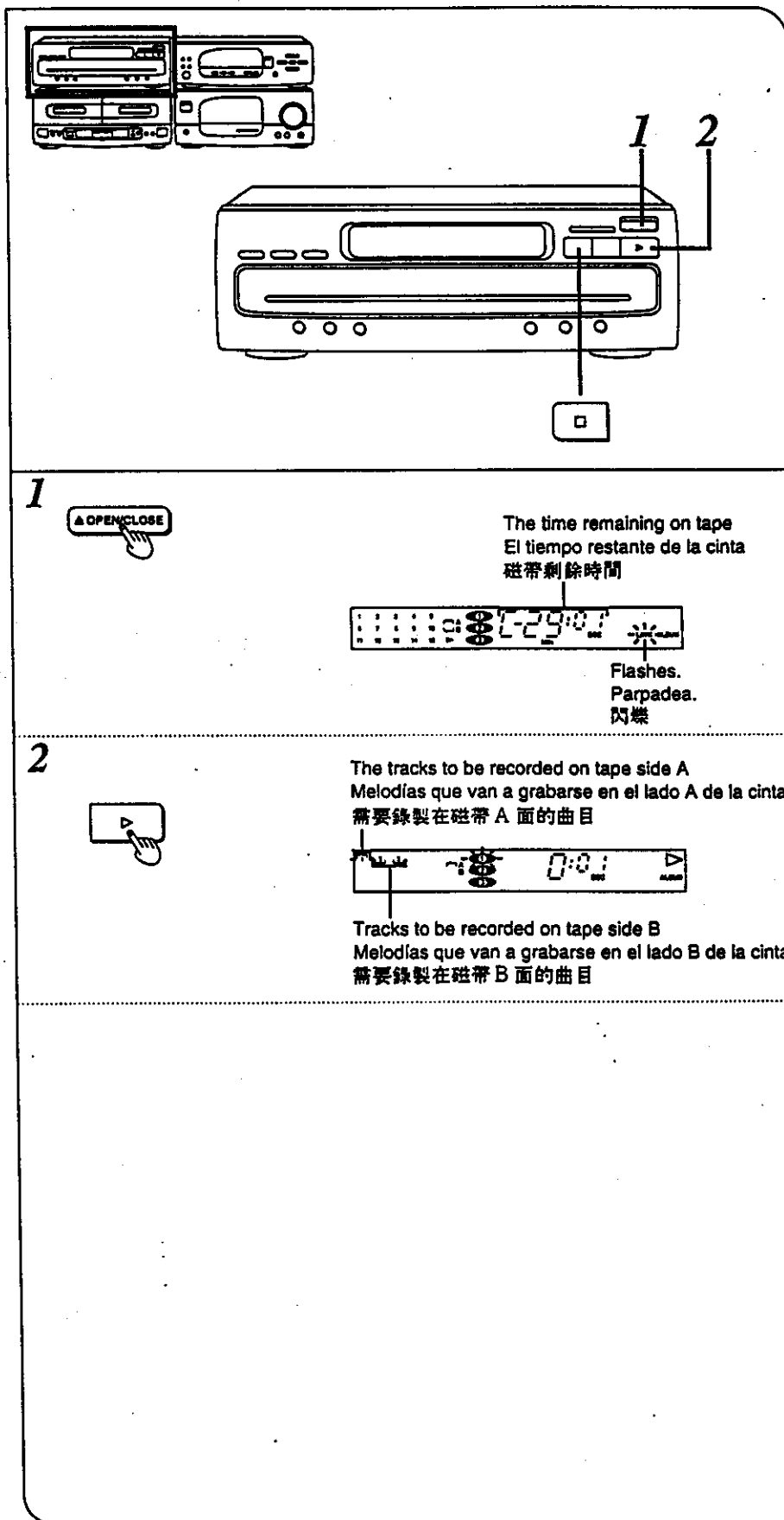

Recording from compact discs

(Continued)

Note

When you record the first compact disc using LAST FADE, tracks to be recorded will not be displayed. However, it is possible to record from another disc.

When the display shows "0:00", you cannot record from another disc. Press to cancel the edit mode.

If the time remaining on the tape is shorter than the length of the tracks to be recorded, you cannot record the tracks. Replace the disc with the tracks shorter than the time remaining on the tape or press to cancel the edit mode.

(To be continued)

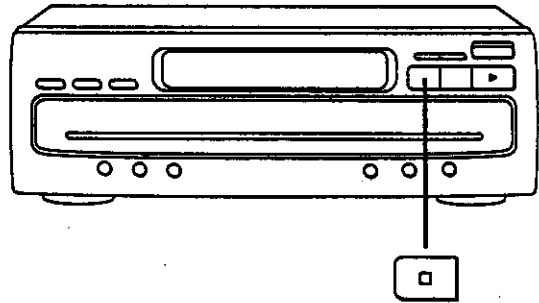
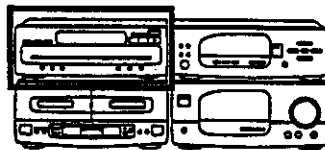

Recording from compact discs

(Continued)

Synchro recording

You can use normal, chrome, and metal tapes for recording.

Check that the tape's erasure prevention tabs (see page 166) are intact, and then insert the cassette into deck 2.

The leader tape must be wound up beforehand. (See page 84.)

1 Press **△ OPEN** to load a cassette in deck 2.

2 Press **CLOSE** to close deck's cassette holder.

3 Press **DOLBY NR** to select Dolby noise reduction B or C mode.

If the tape will not be recorded using Dolby NR, press **DOLBY NR** again so that the Dolby NR indicator (B or C) will go off.

4 Press **REVERSE MODE** to select the reverse mode you want to use.

 : One side will record, and then the tape will stop automatically.

 : Both sides will record (forward side/reverse side), and then the tape will stop automatically.

5 Press **CCRT** to activate the CCRT function.

(See page 82.)

You can record without using the CCRT function.

6 Set the tape direction.

To change the tape travel direction, first press **▷** or **◁** on the cassette deck, then **□**.

▷: Recording from the forward side

◁: Recording from the reverse side

(To be continued)

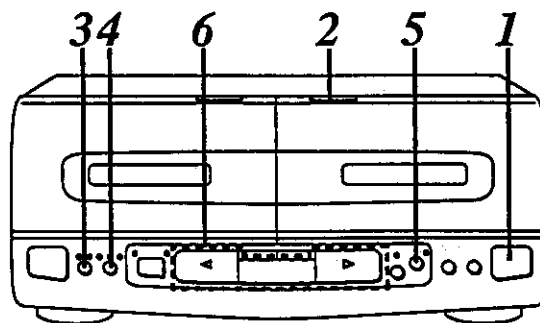
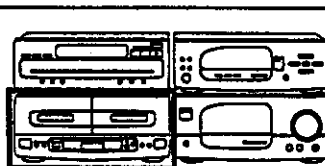

1



2



3



4

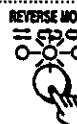

5



6



Recording from compact discs

(Continued)

- 7 Press **▲ OPEN/CLOSE** on the CD changer to load a disc.
Press **▲ OPEN/CLOSE** on the CD changer again to close the disc.
- 8 Press **REC PAUSE** on the cassette deck.
The cassette deck will enter the recording standby state.
- 9 Press **▷** on the CD changer to start recording.
The recording will automatically start corresponding to the tape travel direction indicator.

To stop recording:
Press **□** on the cassette deck.

After the compact disc play finishes:
When one disc is loaded:
The cassette deck will create a non-recorded passage of about 4 seconds, and then go into the recording standby state.

When two or three discs are loaded:
The deck will automatically start recording from the next compact disc.

When you want to cut an unnecessary track while recording:
Before an unnecessary track play will start:

1. Press **□**.
The cassette deck will create a non-recorded passage of about 4 seconds, and then go into the recording standby state.
2. Press **▶▶/▶▶** or **◀◀/◀◀** to skip to the desired track.
3. Press **▷** on the compact disc changer to resume recording.

- To specify the tracks to be recorded:**
1. Follow steps 1 to 7.
 2. Specify the desired discs and tracks using the program play procedure. (See page 56.)
 3. Press **REC PAUSE**.
 4. Press **▷** on the CD changer to start recording.

The recording will automatically start.

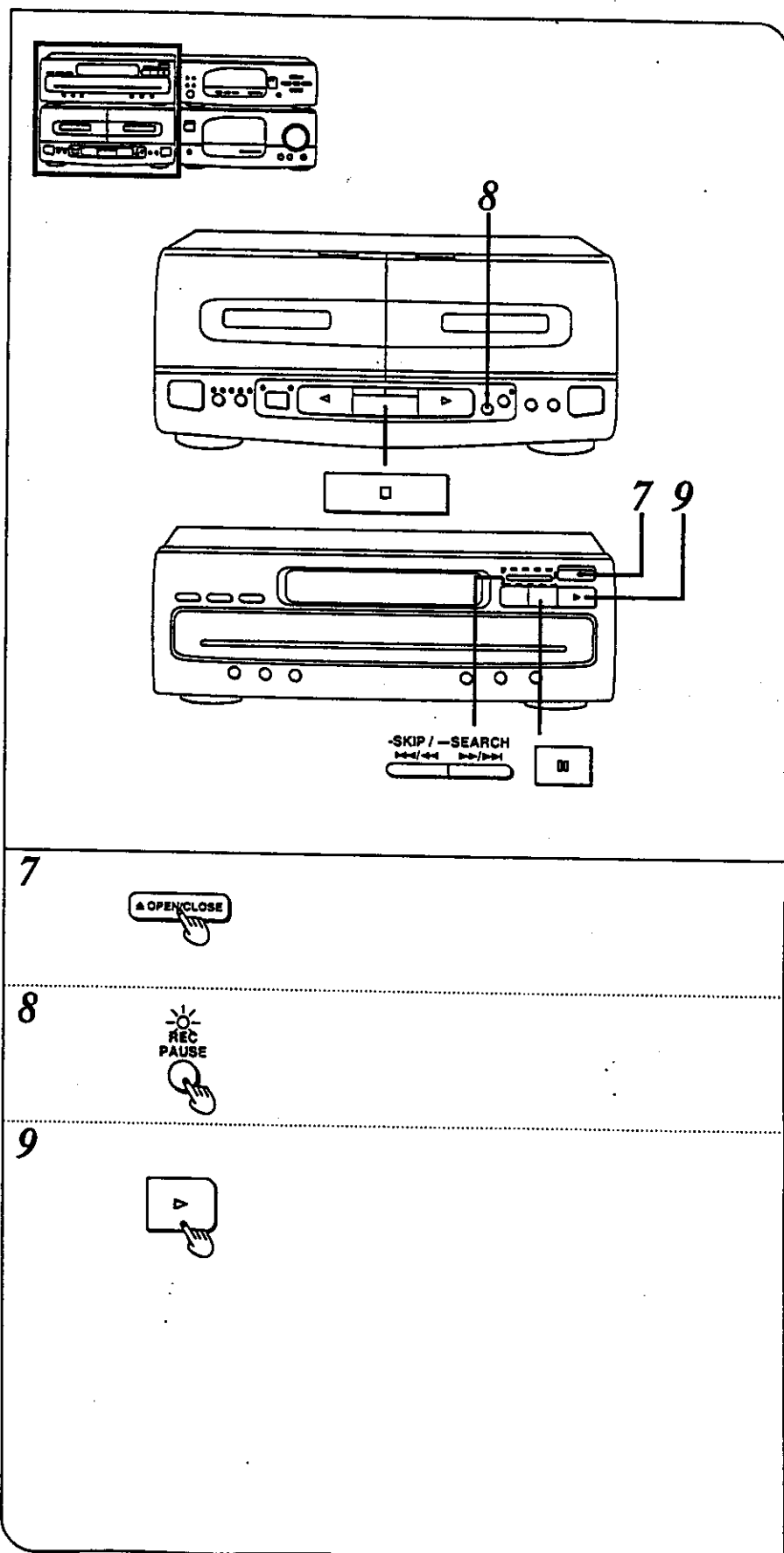

Tape-to-tape recording

You can use normal, chrome and metal tapes for recording.

The recording level and the noise reduction effect of the original (playback) tape will be recorded on the new tape just as they were in the original recording.

Press INT on the tuner/sound processor to select "TAPE".

Check that the tape's erasure prevention tabs (see page 166) are intact, and then insert the cassette into deck 2.

The leader tape must be wound up beforehand. (See page 84.)

1 Load cassettes.

For playback: Into deck 1

For recording: Into deck 2

Insert both cassette with the starting side facing in front.

2 Press CLOSE to close each deck's cassette holder.

3 Select the desired reverse mode.

 : Single-sided recording

 : Two-sided recording (forward side→reverse side)
In case the tape length loaded in deck 2 is longer than a tape in deck 1, deck 1 repeats the playback until deck 2 completes the two-sided recording. (8 times max.)

 : Two-sided recording (forward side→reverse side)

4 Press CCRT to activate the CCRT function.

(See page 82.)

You can record without using the CCRT function.

(To be continued)

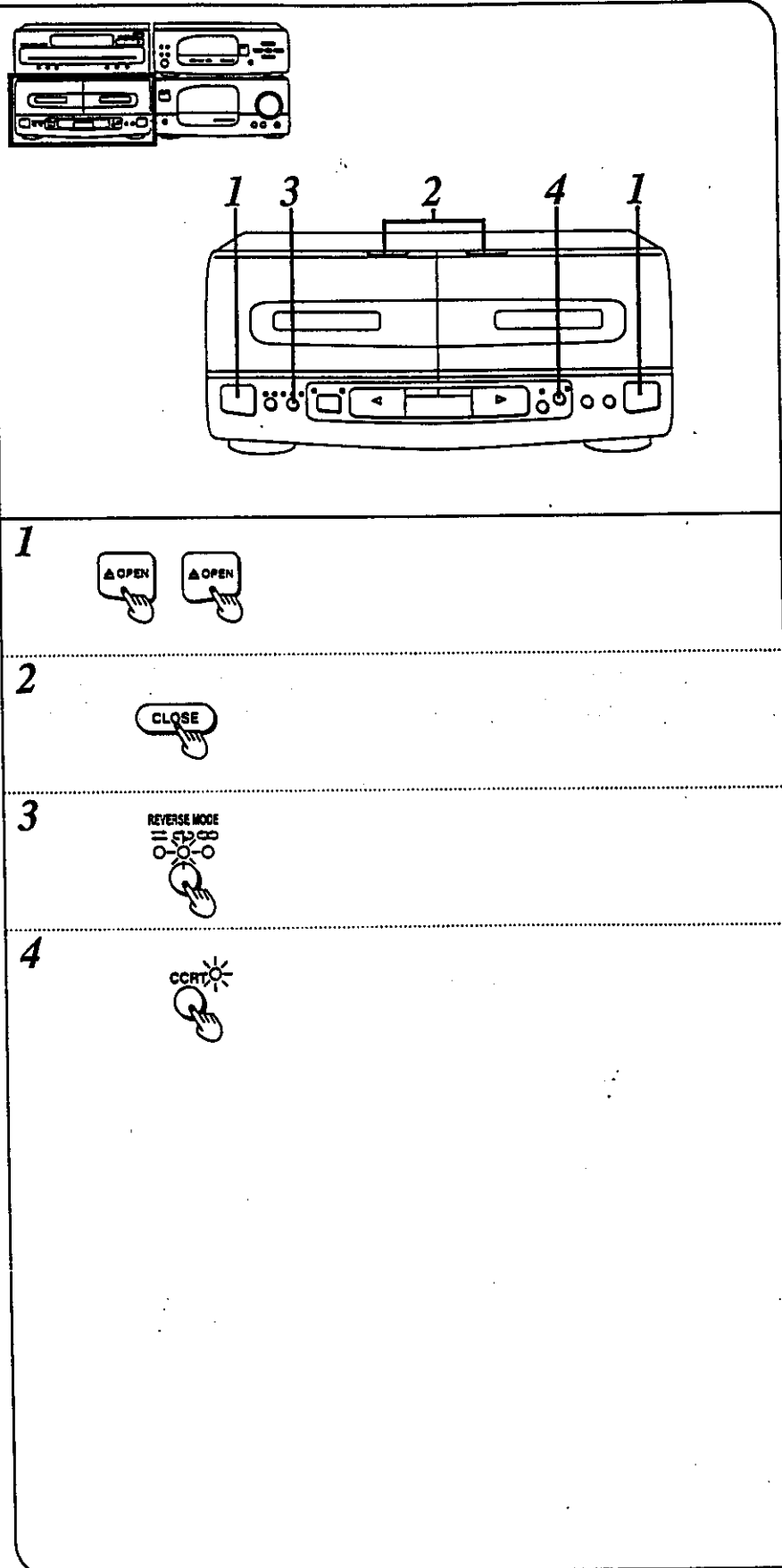

Tape-to-tape recording

(Continued)

5 Set the tape direction to (▷) of deck 1 and deck 2.

Press DECK 1/2 and confirm both deck's tape direction are (▷).

To change the tape direction, first press ▷, and then □.

To record on the reverse side, set deck 2 to (◁) tape direction. (In this case, be sure to rewind the tape to the beginning of the reverse side.)

6 Press one of ONE TOUCH TAPE EDIT (NORMAL or HIGH) to start recording with the desired editing speed.

NORMAL: When you wish to monitor the sound while recording

HIGH: When you wish to record at high speed (about 2 times normal speed)

While recording, both DECK 1 and DECK 2 indicators light. Tape direction indicator shows the tape direction of deck 2.

After recording has finished, both decks will stop.

To stop recording:

Press □.

Both decks will stop.

(To be continued)

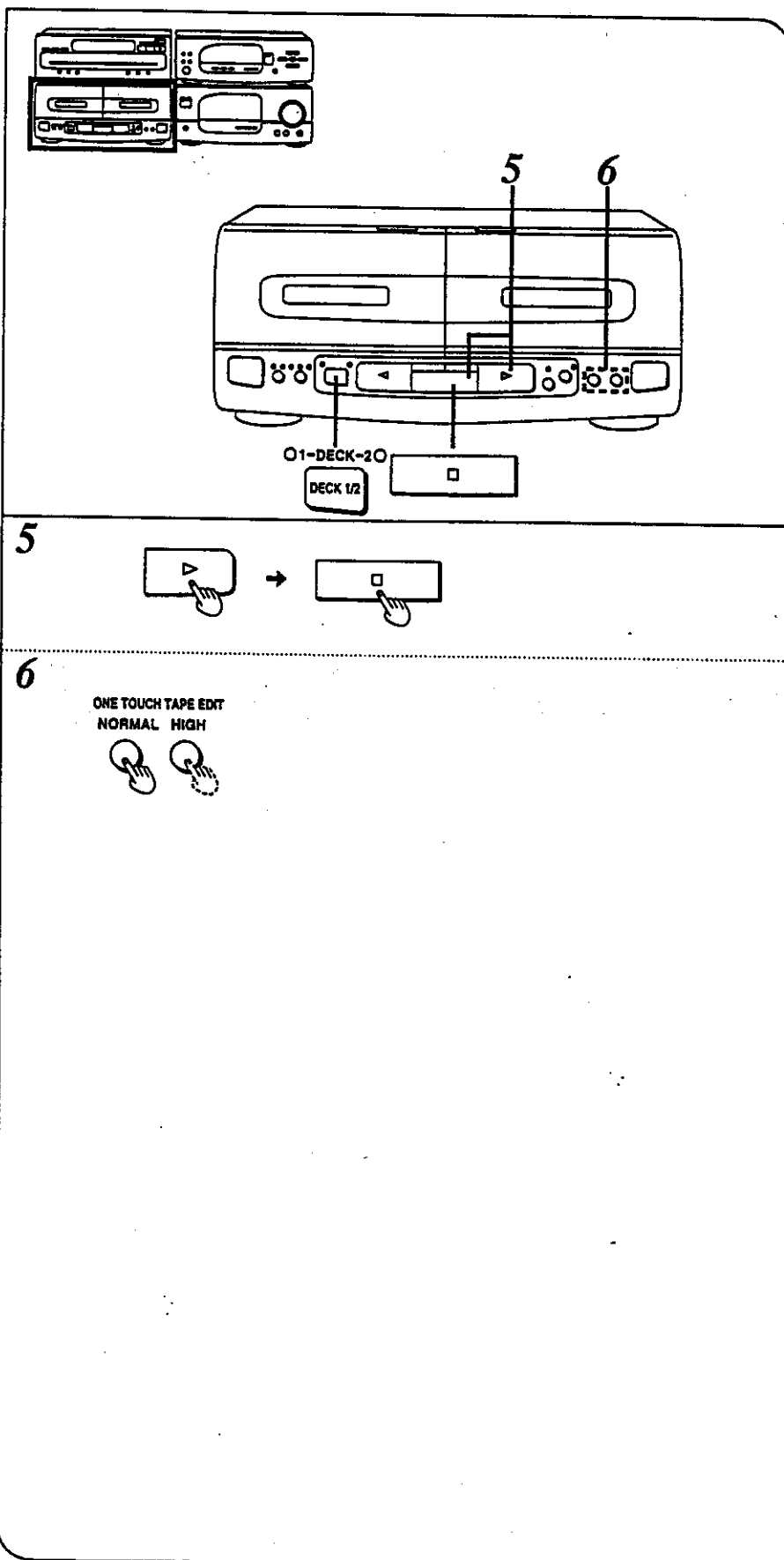



(Continued)

To record on the reverse side of the tape:

Set the deck 2 tape direction to ◁, and then press NORMAL or HIGH.

To enjoy another source while recording:

Press ▷ on the compact disc player or TUNER/BAND on the tuner/sound processor, and start the sound source.

You can change the volume level and tone quality without affecting the recording.

For your reference:

For optimum results, use an editing tape of the same or higher quality than the playback tape.

Notes

- Some TV sets generate noise that could be recorded during tape-to-tape recording. To prevent the possibility of this, do not use this system close to a TV set.
- Do not press CD edit recording buttons (J. FIT, ALBUM, LAST FADE) while tape-to-tape recording is in progress. It changes the tape-to-tape recording to the CD edit recording mode.
- You cannot expect special tone quality and equalization effects for tape-to-tape recording.

Changing the tone

About equalization curves (EQ)

Use this sound mode when you want to change the tone according to the type of music.

There are 5 equalization curves preprogrammed to this system. (See page 116.)

About simulated listening environments (SPACE)

Use this sound mode when you want to create the "live" performance sound.

There are 3 simulated listening environments preprogrammed to this system. (See page 120.)

You can adjust equalization curves and simulated listening environment as you like, to store them as "USER" mode. (See page 122.)

To retrieve the preprogrammed equalization curves (EQ mode) **A**

5 types of equalization curves preprogrammed to this system.

- 1 Press **MODE** to select EQ mode. Each time you press **MODE**, EQ and **SPACE** mode will be alternately switched.
EQ → SPACE

The display shows one of the EQ mode (HEAVY, CLEAR, SOFT, CAR, HP ST) which is previously retrieved.

- 2 Press and hold **MODE** to select **PRESET** mode. Each time you press and hold **MODE**, **PRESET** and **USER** mode will be alternately switched.

(To be continued)

A

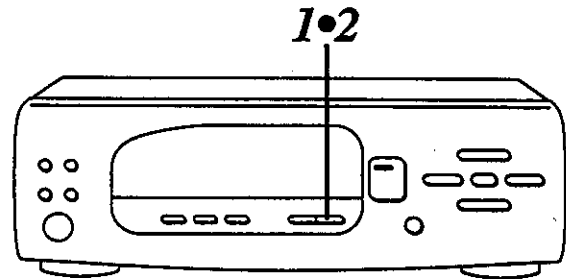
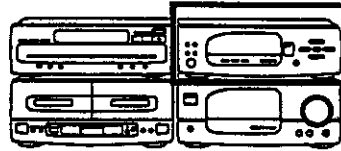

1



Lights.
Se enciende.
亮起

2

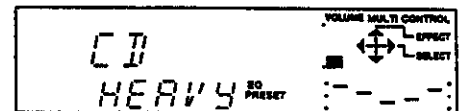

Changing the tone

(Continued)

To retrieve the preprogrammed simulated listening environments (SPACE mode)

3 types of simulated listening environments are preprogrammed to this system.

1 Press MODE to select SPACE mode.

Each time you press MODE, EQ and SPACE mode will be alternately switched.

EQ → SPACE

The display shows one of the SPACE mode (DISCO, LIVE, HALL) which is previously retrieved.

2 Press and hold MODE to select PRESET mode.

Each time you press and hold MODE, PRESET and USER mode will be alternately switched.

3 Press ► or ◀ to select the desired simulated listening environments.

Each press of ► advances the simulated listening environments setting as follows.

DISCO → LIVE → HALL

Pressing ◀ advances the equalization setting conversely.

(To be continued)

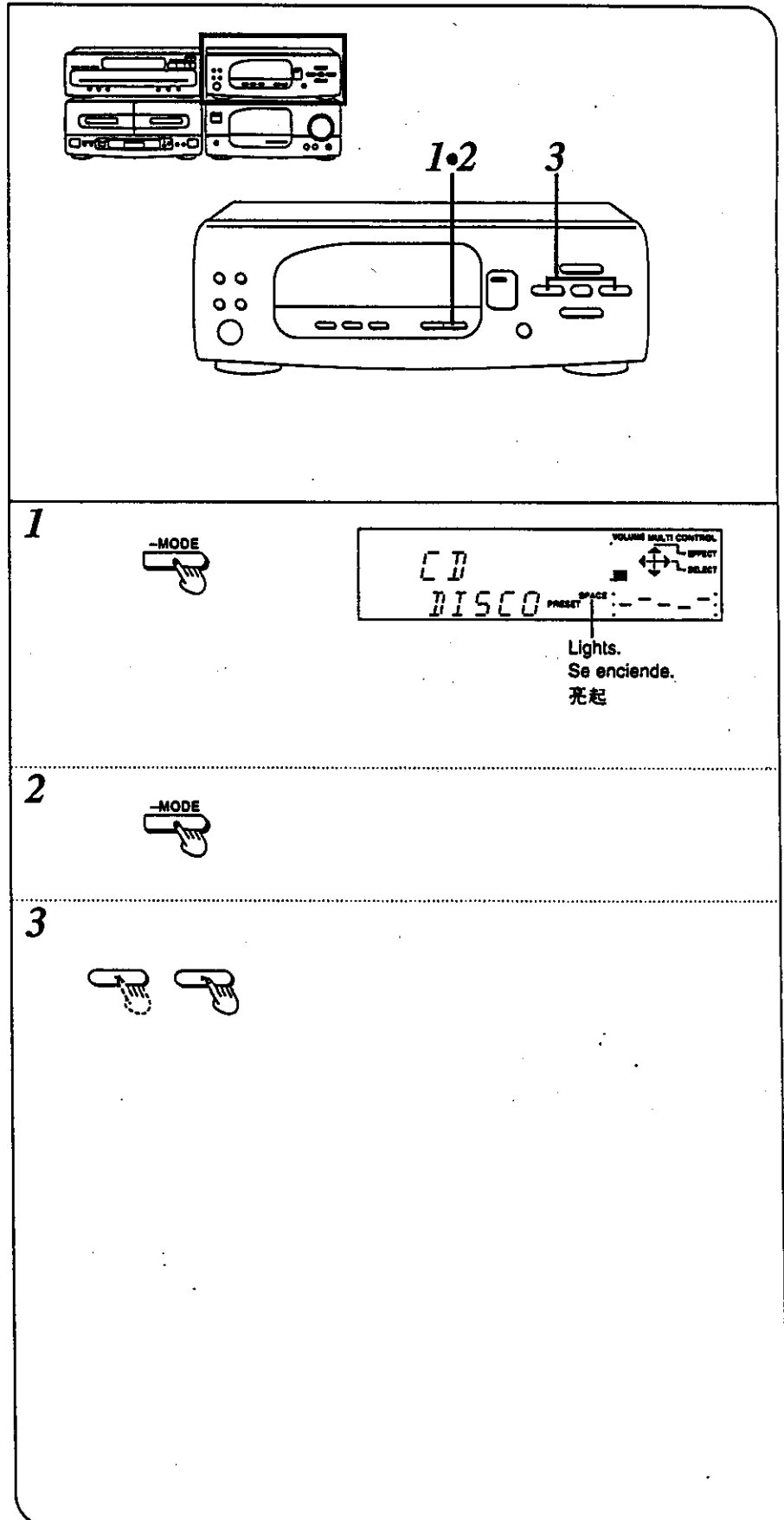

Changing the tone

(Continued)

About the pre-programmed simulated listening environments

1 DISCO

Use to create powerful bass sounds found in discos.

2 LIVE

Use primarily for vocal pieces to add gloss to the vocals.

3 HALL

Use to impart a deep bass and spread which will make you feel as if you were in a large concert hall.

To cancel the SPACE mode:

Press ON/FLAT to select FLAT.

For your reference:

You can record with desired simulated listening environments. To playback such recordings, press ON/FLAT to select FLAT.

When listening to the radio broadcast:

After pressing MODE (on steps 1 and 2), proceed to the next step within 10 seconds. If not, the display will return to the tuning/preset mode. In this case, press MODE twice, and proceed to the next step.

Note

During CD edit recording, you cannot alter the SPACE mode.

(To be continued)

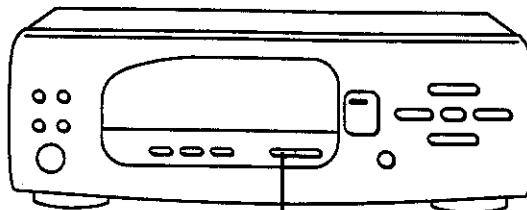
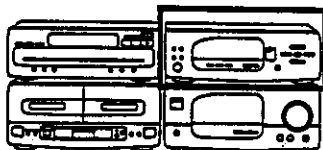

ON/FLAT

1 DISCO

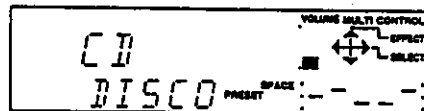

2 LIVE

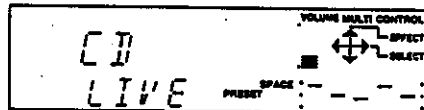

3 HALL

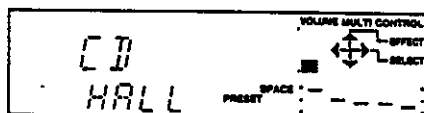

Changing the tone

(Continued)

To adjust EQ and SPACE

You can adjust equalization curves and simulated listening environment as you like, and store them as the USER mode in its memory.

- 1 Select the equalization curve or simulated listening environment of which you want to adjust the tone.
(See pages 114, 116, 118 and 120.)
- 2 Press ▲ or ▼ to adjust the equalization curve or simulated listening environment.
▲: To increase the effect
▼: To decrease the effect

Once you have made the adjustment, the system automatically stores the simulated listening environment or equalization curve as the USER mode in its memory.

To retrieve the USER mode:

1. Press MODE to select EQ or SPACE mode.
2. Press and hold MODE to select USER.
3. Press ► or ◀ to select the desired equalization curve or simulated listening environment.

For your reference:

- Any adjustment will not affect the PRESET modes (equalization curves or simulated listening environments preprogrammed to this system).
- USER modes will stay in the system's memory for approximately 2 weeks even if the power supply cord is disconnected.

(To be continued)

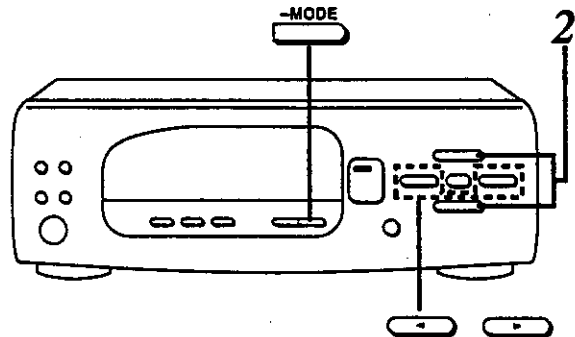
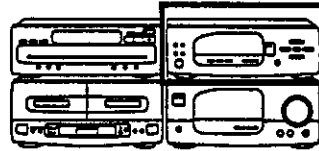

1

2

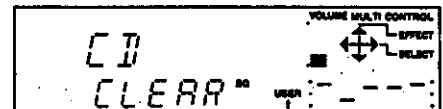

Lights.
Se enciende.
亮起

Changing the tone

(Continued)

To listen with augmented bass (V. BASS)

Press V. BASS to ON.

To cancel the V. BASS effect:
Press V. BASS once again.

Notes

- You cannot make a recording with the V. BASS effect. While recording, V. BASS mode cannot be activated.
- V. BASS indicator goes out while recording, and lights when recording finishes.

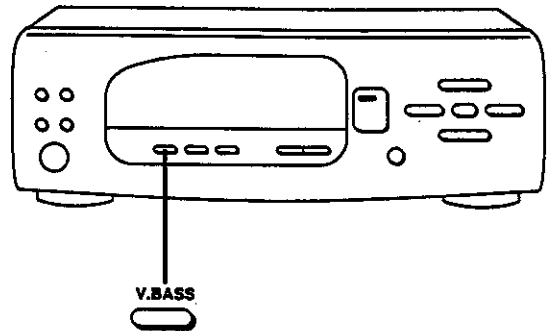
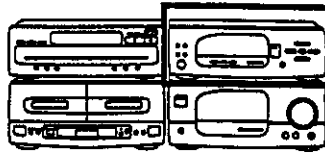

V.BASS



V. BASS indicator lights.
El indicador V. BASS se encenderá.
V.BASS 指示燈會亮起。

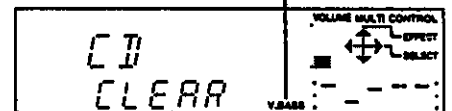

Using the timer

About the types of timer operation

Make sure that you have completed "Setting the time" on page 34.
There are 3 types of timer operation.

Play timer

(see pages 128, 130 and 132): **A**

Select this timer when you want to use the timer as an alarm clock. You can wake up with listening to music (CD, tuner, tape) at a desired volume level and time.

Record timer

(see pages 134, 136 and 138): **B**

Select this timer when you want to use the timer to record a midnight program or while you are out. The system will record a desired radio broadcast at a desired time.

Sleep timer (see page 140): **C**

Select this timer when you want to use the timer to switch off the music automatically as you can fall asleep while listening. The system will go into power standby condition after assigned time has passed.

You can use above timer mode in conjunction. (See pages 142 and 144 for details.)

(To be continued)

A

Well, at 6:30, play a CD with a little louder volume...

A las 6:30 me despertaré escuchando un disco compacto con el volumen un poco más alto...

好的, 在 6:30, 用稍微大一點的聲音欣賞 CD

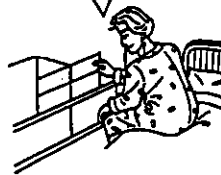

Good morning!

¡Buenos días!

早上好!



B

Before going out, set the broadcast station and time.

Antes de salir pondré la emisora de radiodifusión y la hora.

在出門前, 設定好收音機電台和定時器。

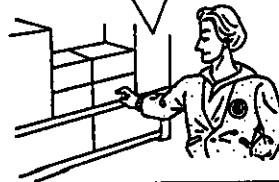

The recording will be made while you are out.

La grabación se realizará estando usted ausente.

在您外出時可進行錄音。



C

Set the system to go into standby mode after 30 minutes.

Prepararé el sistema para que se ponga en el modo de espera después de 30 minutos.

將本機設定在 30 分鐘後處於待命狀態。



OFF!

¡APAGADO!

關機!

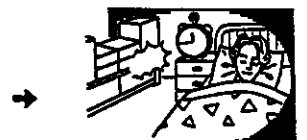

Using the timer

(Continued)

Setting the play timer

The following example shows how to set the play timer for playing a CD at -48 dB every day from Monday through Friday 6:30 to 7:40.

- 1 Adjust the volume level for the timer play on the amplifier.
- 2 ① Press **CLOCK/TIMER** three times to select **PLAY**.
Within 10 seconds:
② Press **SET**.
- 3 ① Press **▶** or **◀** to select the day.
② Press **SET**.
- 4 ("ON" time setting)
① Press **▶** or **◀** to select the hour.
② Press **SET**.
③ Press **▶** or **◀** to select the minutes.
④ Press **SET**.
- 5 ("OFF" time setting)
① Press **▶** or **◀** to select the hour.
② Press **SET**.
③ Press **▶** or **◀** to select the minutes.
④ Press **SET**.
- 6 ① Press **▶** or **◀** to select the desired source.
② Press **SET**.

When you select tuner, select a desired preset channel using **▶** or **◀**, and then press **SET**.

(To be continued)

1 VOLUME DOWN UP

2 CLOCK/TIMER → SET

3~6 (CLOCK/TIMER) → (▶ ◀) → SET

1 VOLUME MULTI CONTROL Tuning PRESET REPORT

2 MULTI CONTROL SELECT SET 0

3 VOLUME MULTI CONTROL ON DEPLAY SELECT SET 0

4 VOLUME MULTI CONTROL ON DEPLAY SELECT SET 0

5 VOLUME MULTI CONTROL OFF DEPLAY SELECT SET 0

6 VOLUME MULTI CONTROL ON DEPLAY SELECT SET 0



The diagram illustrates the step-by-step process of setting the play timer. It shows the stereo's display changing from '-48dB FLAT' to 'PLAY', then to '0:00', and finally to '6:00', '6:30', '7:30', and '7:40'. Each step is accompanied by a hand icon showing the button being pressed.

Using the timer

(Continued)

- 7 Prepare for the play.**
When you play a CD:
Load a disc.
When you load two or three discs:
Press one of the disc buttons to select which disc you want to play, and then proceed to next step.
When you play a tape:
Load a tape.
- 8 Press POWER on the amplifier to switch the power to standby mode.**
Please confirm  PLAY appears on the display. The timer play will start at the preset time with volume increasing gradually up to the volume level you preset.

To cancel the timer:

Press  PLAY to go out  PLAY on the display.

The play timer will not function, but the play timer setting will stay in the memory.

If you make an error:

Press CLOCK/TIMER to return to step 1.

About the variation of the day setting:

One day from
Sunday to Saturday: SUN...SAT
Everyday from
Sunday to Saturday: SUN-SAT
Everyday from
Monday to Saturday: MON-SAT
Everyday from
Monday to Friday: MON-FRI
Saturday and
Sunday only: SUN, SAT

To confirm the play timer:

Press CLOCK/TIMER to show " PLAY" on the display.

The display will show the ON time, OFF time, the source you select, and the volume level in 2 seconds steps.

To change the play timer setting:

Follow the procedure from the first step.
(See pages 128 and 130.)

(To be continued)

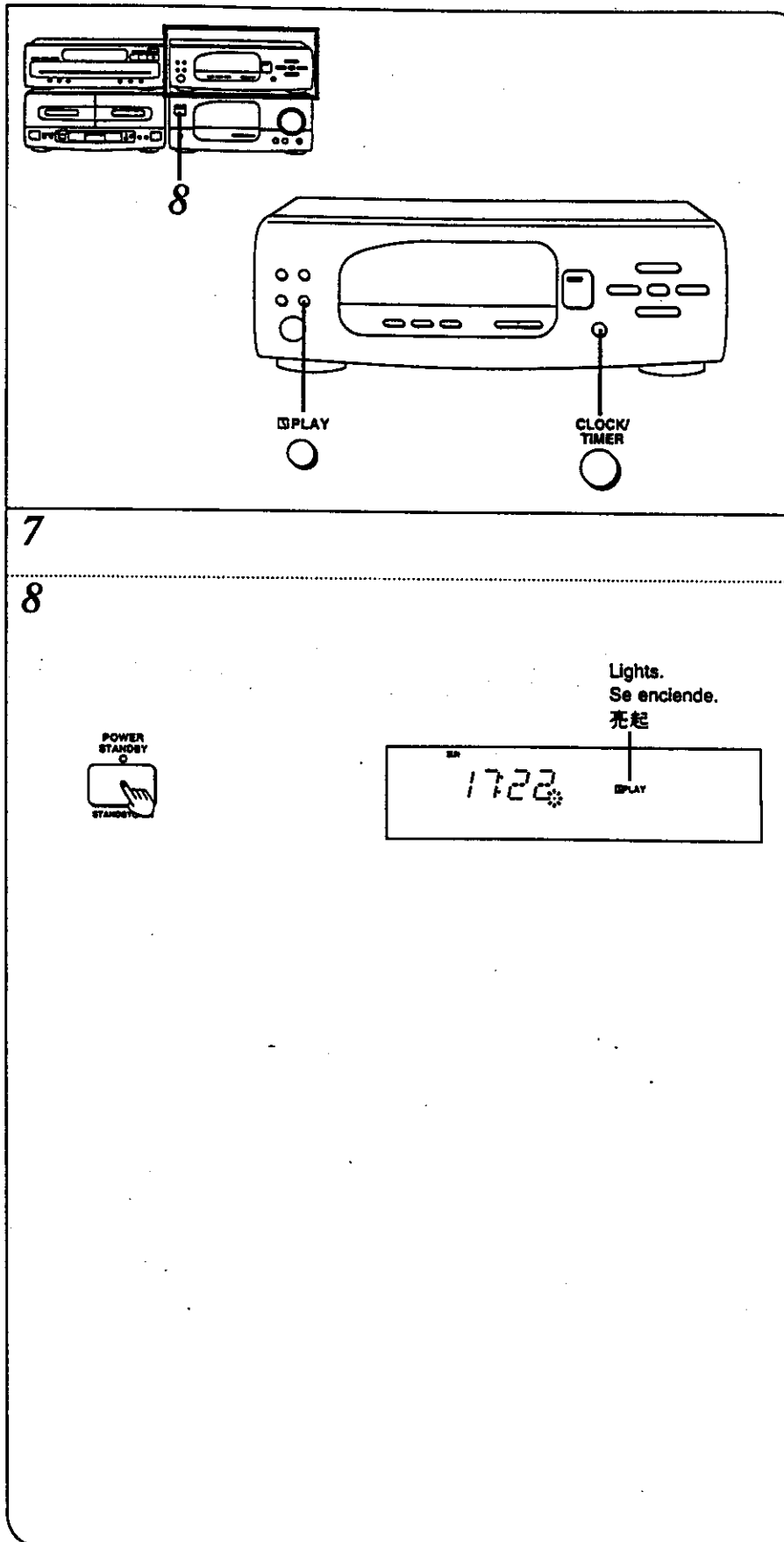

Using the timer

(Continued)

Using the timer at the same time setting continuously:

You can accomplish this even if the system is in the standby mode.

1. Press **▶** PLAY to show **▶** PLAY on the display.
2. Press POWER on the amplifier to switch the power to standby mode.

To enjoy the desired source after the timer setting is completed:

1. Start playing the desired source.
Even if you change the volume level or music source, the timer play will start with the preset condition.
2. Press POWER on the amplifier to standby mode after enjoying the play.

Notes

- This system retains the ON/OFF time settings until you make a new setting. In case you make a new ON time setting which is later than the previous OFF time setting, the system automatically advances the day you set on the step 3. (See page 128.) When you reset the OFF time, the day setting will return to the original setting.
- You cannot make the ON time and OFF time same setting.
- If the power is on, the timer will not function. The system must be in the standby mode.
- The play timer will function until you cancel the play timer mode.
- If you switch the power to standby mode while play timer is functioning, the OFF time setting will be cancelled.

For your reference:

When you insert cassettes in both deck 1 and deck 2, deck 1 has priority for timer play on tape.

(To be continued)

Using the timer

(Continued)

Setting the record timer

The following example shows how to set the record timer for, recording FM preset channel no. 1 on Saturday from 18:30 to 20:00.

- 1 ① Press **CLOCK/TIMER** twice to select **REC**.
Within 8 seconds:
② Press **SET**.
- 2 ① Press **▶** or **◀** to select the day.
② Press **SET**.
- 3 ("ON" time setting)
① Press **▶** or **◀** to select the hour.
② Press **SET**.
③ Press **▶** or **◀** to select the minutes.
④ Press **SET**.
- 4 ("OFF" time setting)
① Press **▶** or **◀** to select the hour.
② Press **SET**.
③ Press **▶** or **◀** to select the minutes.
④ Press **SET**.
- 5 ① Press **▶** or **◀** to select the desired preset channel.
② Press **SET**.
- 6 Prepare for recording.
 1. Insert a cassette into deck 2.
 2. Select the Dolby NR.
 3. Select the reverse mode.
 4. Select the tape travel direction.

(To be continued)

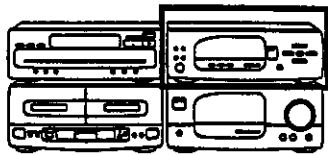

CLOCK/TIMER 1 (○ → SET) 2~5 (◀ ▶ → SET)

- 1
 - ① **CLOCK/TIMER** → ② **SET**
 - Display: **0REC**
- 2
 - ① **▶** → ② **SET**
 - Display: **000**
- 3
 - ① **▶** → ② **SET**
 - ③ **▶** → ④ **SET**
 - Display: **18:00**
 - Display: **18:30**
- 4
 - ① **▶** → ② **SET**
 - ③ **▶** → ④ **SET**
 - Display: **20:30**
 - Display: **20:00**
- 5
 - ① **▶** → ② **SET**
 - Display: **FM 88.10**
- 6

Using the timer

(Continued)

7 Press **POWER** on the amplifier to switch the power to standby mode.

Please confirm **REC** appears on the display.

The sound will be automatically muted during timer recording.

To cancel the timer:

Press **REC** to go out **REC** on the display.

The record timer will not function, but the record timer setting will stay in the memory.

If you make an error:

Press **CLOCK/TIMER** to return to step 1.

About the variation of the day setting:

One day from

Sunday to Saturday: SUN...SAT

Everyday from

Sunday to Saturday: SUN-SAT

To confirm the record timer:

Press **CLOCK/TIMER** to show **REC** on the display.

The display will show the ON time, OFF time, the broadcast station you select, in 2 seconds steps.

(To be continued)

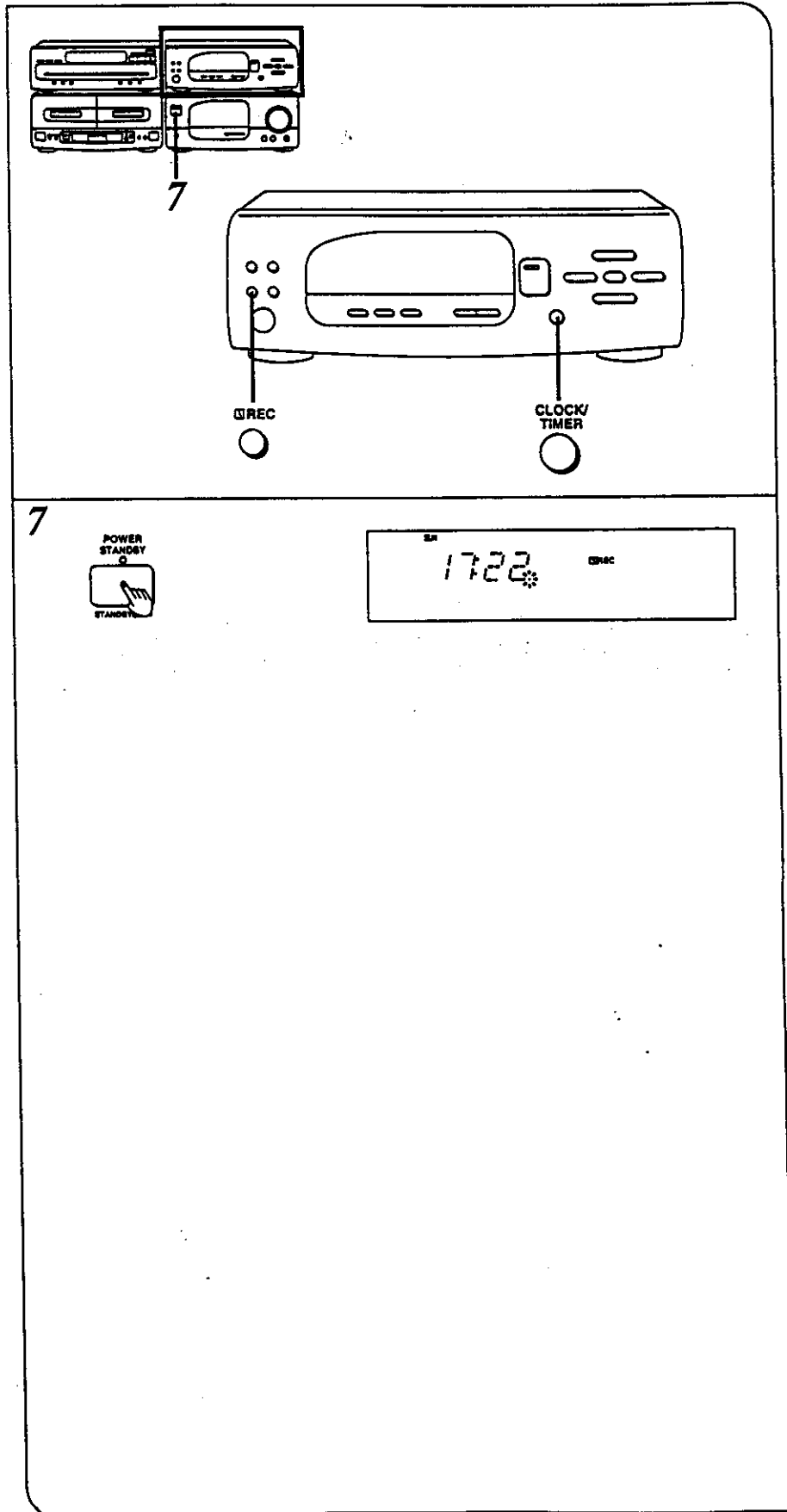

Using the timer

(Continued)

To change the record timer setting:

Follow the procedure from the first step.

(See pages 134 and 136.)

Using the timer at the same time setting continuously:

You can accomplish this even if the system is in the standby mode.

1. Press REC to show REC on the display.
2. Press POWER on the amplifier to switch the power to standby mode.

To enjoy the desired source after the timer setting is completed:

1. Start playing the desired source.
When listening to a cassette tape, use the deck 1.
Even if you change the music source, the timer recording will start with the preset condition.
2. After enjoying the source, prepare for recording, and then press POWER on the amplifier to standby mode.

Notes

- This system retains the ON/OFF time settings until you make a new setting. In case you make a new ON time setting which is later than the previous OFF time setting, the system automatically advances the day you set on the step 3. (See page 134.) When you reset the OFF time, the day setting will return to the original setting.
- You cannot make the ON time and OFF time same setting.
- If the power is on, the timer will not function.
- Once the record timer operation finishes, it clears the record timer mode (except for "everyday from Sunday to Saturday" mode).
- When you want to record a same program over several weeks (except when you select "everyday from Sunday to Saturday" mode), press REC to show REC on the display after the timer recording has finished.

For your reference:

While timer recording is taking place, the volume level will be automatically muted.

(To be continued)

Using the timer

(Continued)

To use the sleep timer **A**

You can use this timer function to switch the power to the standby mode at a specified time (within a range of 1 minute to 120 minutes from the present time).

The following example shows how to set the system to standby mode after 30 minutes.

- 1** While enjoying the desired source
- ① Press **CLOCK/TIMER** four times to select "SLEEP".
 - Within 7 seconds:
 - ② Press **SET**.
- 2**
- ① Press **▶** or **◀** to select the desired length of time.
 - ② Press **SET**.
 - Please confirm "SLEEP" appears on the display.

To cancel the sleep timer mode: **B**
 Press **SLEEP** to go out the "SLEEP" on the display.
 The time setting will remain in the unit's memory.

To confirm the time remaining on the sleep timer:
 Press **CLOCK/TIMER** four times.

To change the time setting while sleep timer is functioning:
 Follow procedure from the beginning.

If you want to operate the system again on the same sleep time:
 Press **SLEEP** on the remote control to show "SLEEP" on the display.

(To be continued)

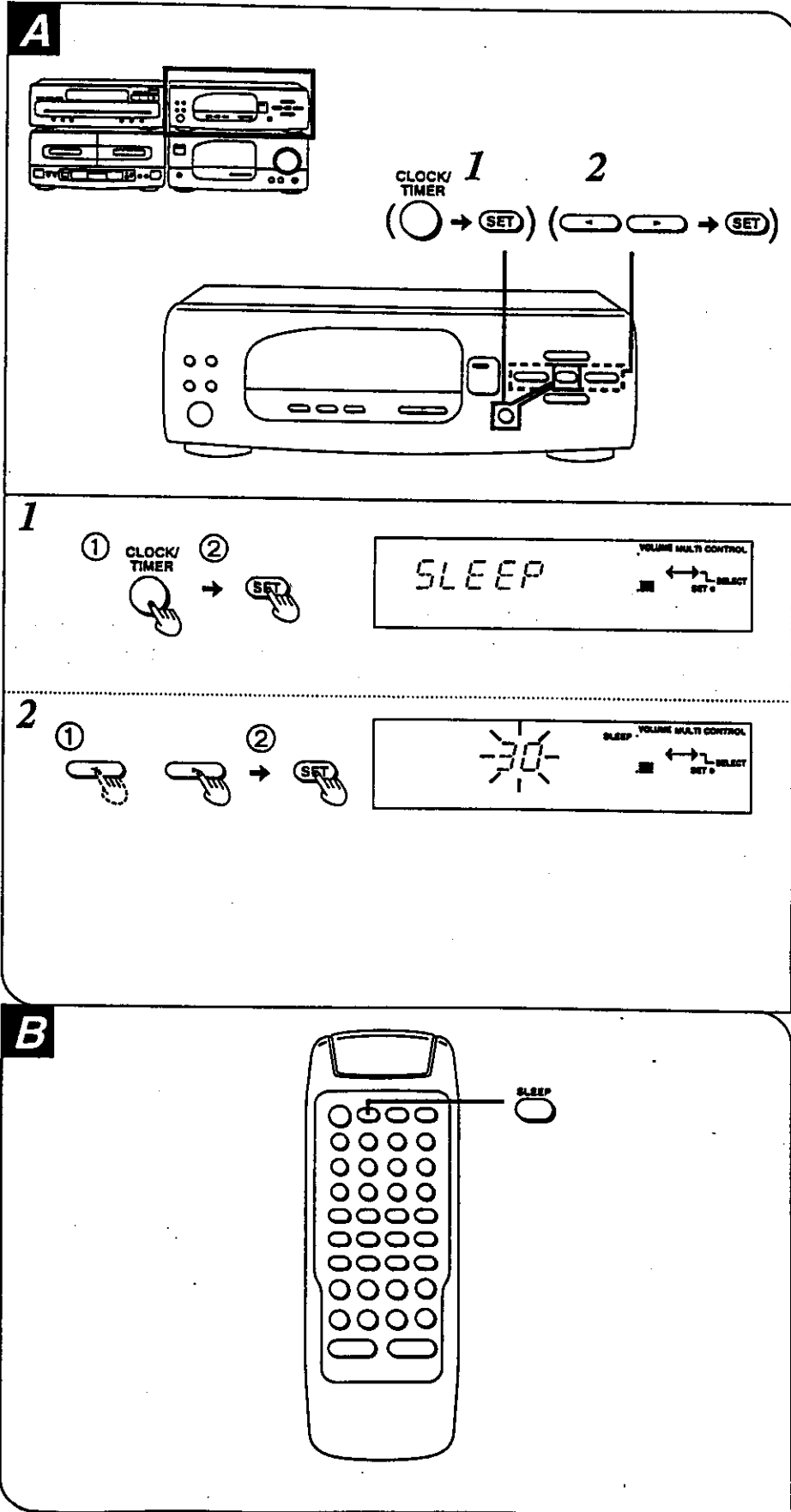

Using the timer

(Continued)

To use each timer mode in conjunction

To go to sleep listening to a tape, and wake up the next morning listening to a compact disc, and record from a radio broadcast while going out

1. Make a record timer setting.
(See pages 134, 136 and 138.)
2. Make a play timer setting for a compact disc.
(See pages 128, 130 and 132.)
Be sure to set the timer play to off before the timer recording will start.
3. Play back the tape in deck 1, and adjust the volume level.
(Select "←" of the reverse modes.)
4. Press CLOCK/TIMER to select SLEEP timer, and set the sleep time.
(See page 140.)

To go to sleep listening to a compact disc, and then to make a timer recording from a radio broadcast

1. Make a record timer setting.
(See pages 134, 136 and 138.)
2. Play a compact disc, and adjust the volume level.
3. Press CLOCK/TIMER to select SLEEP timer, and set the sleep time.
(See page 140.)
Be sure to set the sleep timer to off before the timer recording will begin.

(To be continued)

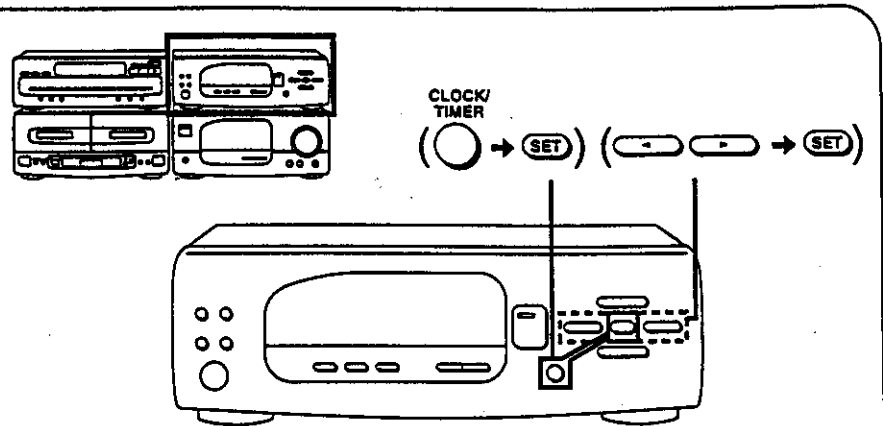



(Continued)

To make a timer recording from a radio broadcast while sleeping, and wake up the next morning listening to a cassette tape

1. Make a record timer setting.
(See pages 134, 136 and 138.)
2. Make a play timer setting for deck 1, and switch the power to standby mode.
(See pages 128, 130 and 132.)
Be sure to set the record timer to off before the play timer will begin.

To go to sleep listening to an FM broadcast and wake up the next morning listening to a compact disc

1. Make a play timer setting for compact disc. (See pages 128, 130 and 132.)
2. Tune in the desired band and station, and adjust the volume level.
3. Press CLOCK/TIMER to select SLEEP timer, and set the sleep time.
(See page 140.)

Timer sequence of priority:

Sleep timer, record timer, play timer is the timer operation of priority in order. Be sure not to make each timer setting overlap.

Example 1: A

The sleep timer setting has priority, so the record timer will not function.

Example 2: B

The record timer setting has priority, so the play timer will not function.

For your reference:

- When the OFF time of the record timer and the ON time of the play timer are the same, both timers will function.
- When the OFF time of the play timer and the ON timer of the record timer are the same, both timers will function.

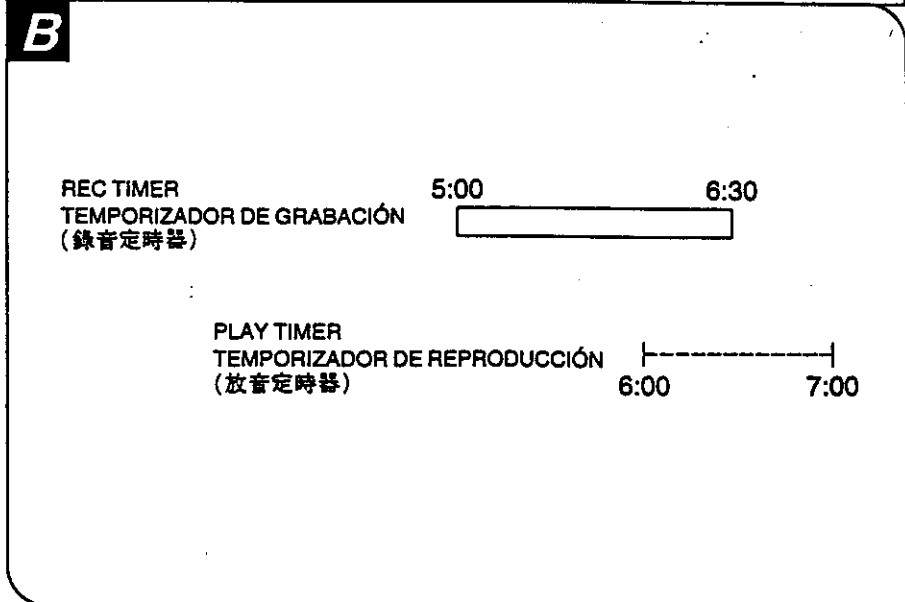
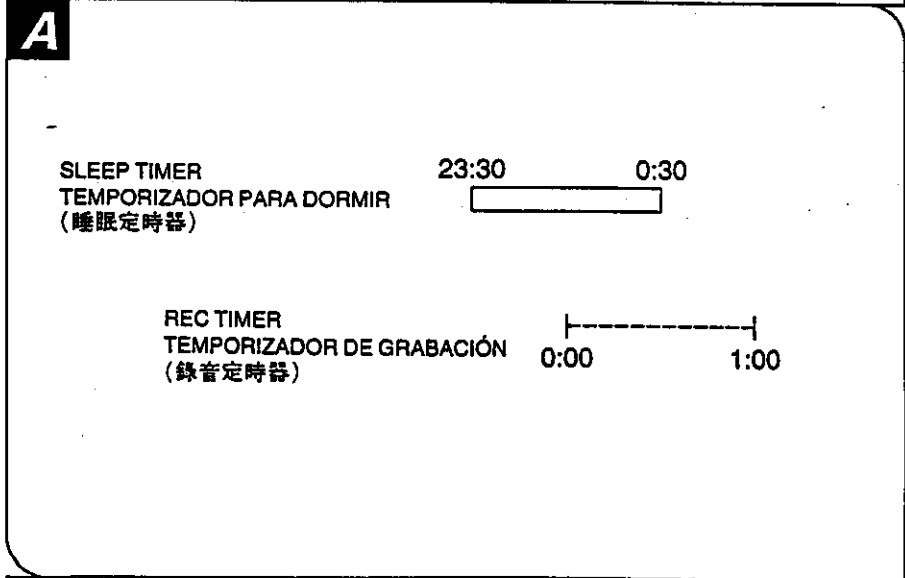
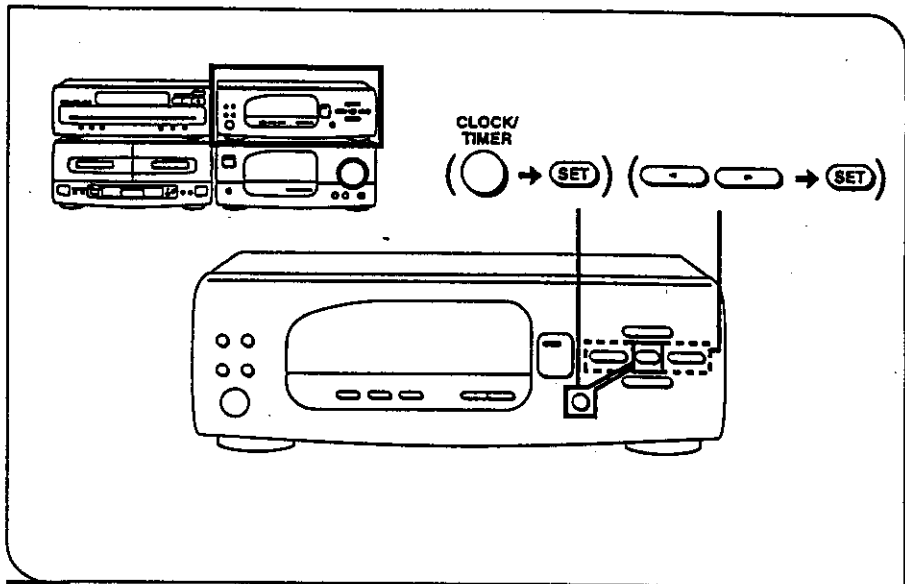

Enjoying the microphone mixing

This function mutes the vocal track but leaves the accompaniment allowing you to enjoy "KARAOKE" (singing with an accompaniment).

- 1** Connect the microphone plug to the MIC jack after reducing the volume level.
Plug type: M6 MONO type
(For areas except Australia and New Zealand)
You can connect another microphone jack to the second one.
- 2** Start playing a compact disc.
- 3** Press KARAOKE to ON.
"VOICE MUTE", "L ONLY", "R ONLY" and light off (FLAT) will be displayed in order each time you press KARAOKE.

VOICE MUTE	You can use a normal CD.
L ONLY or R ONLY	You can use a sound multiplex CD, or CD graphics.
Light off (FLAT)	You can use normal karaoke tape, a normal karaoke CD, or CD graphics.

- 4** Start microphone mixing, and adjust the microphone level.

To adjust the reverberation sound

(For areas except Australia and New Zealand)

- 1.** Press ECHO.
The ECHO indicator will light.
- 2.** Adjust the reverberation sound using ▲ or ▼.
You can adjust the reverberation sound within the range of 1.0 seconds to 1.6 seconds.
To cancel, press ECHO again.

Notes

- During CD edit recording, you cannot alter the ECHO mode.
- The ECHO mode cannot be activated when you select FM or MW or LW.
- You cannot alter the ECHO mode without the microphone.

(To be continued)

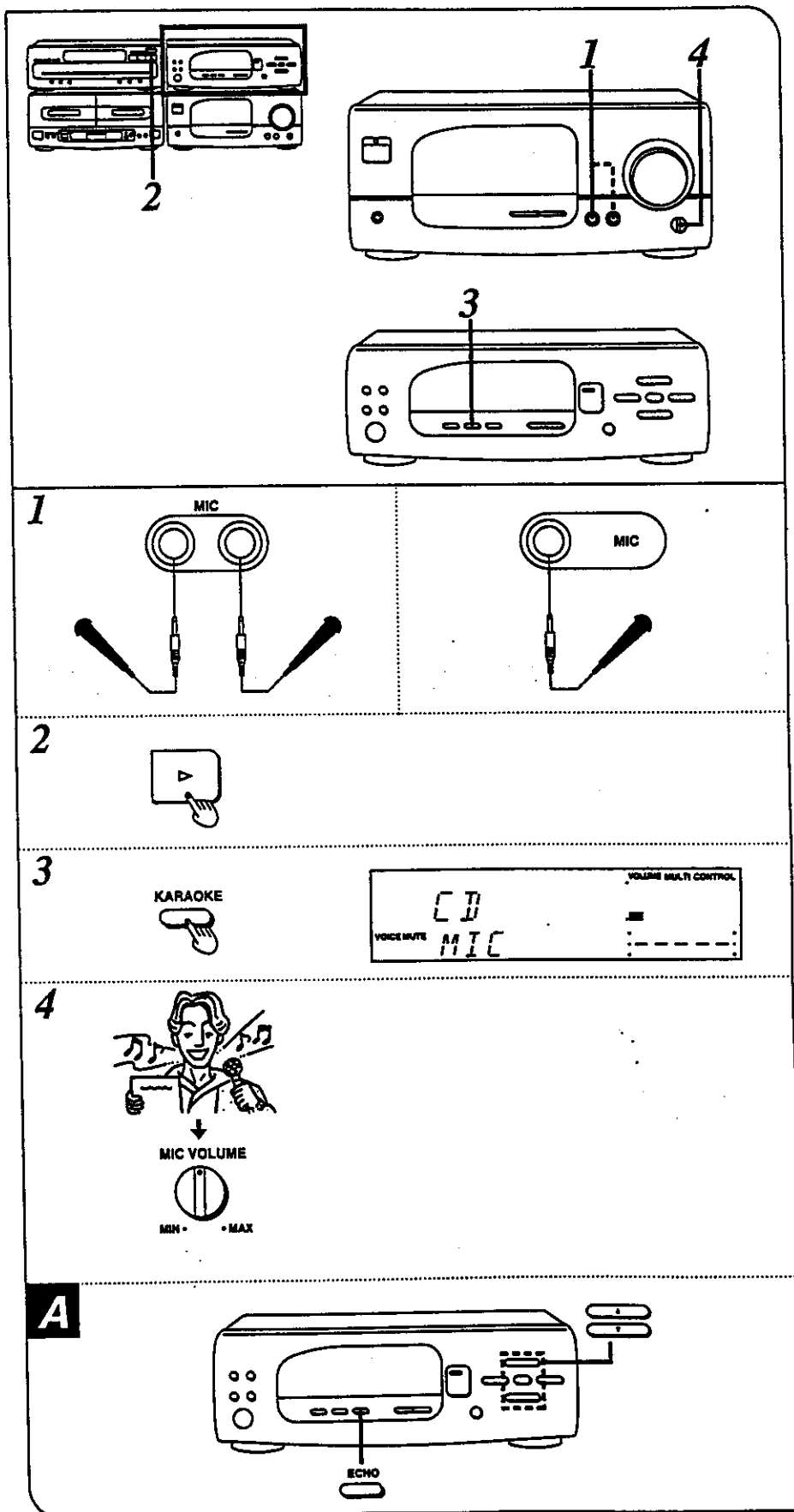

Enjoying the microphone mixing

(Continued)

To cancel the "KARAOKE" mode:
Press KARAOKE to go out the indicator.

When VOICE MUTE lights:
Press 3 times.

When L ONLY lights:
Press twice.

When R ONLY lights:
Press once.

To record of your "KARAOKE" performance:

Start recording on deck 2, then start "KARAOKE". To playback the tape recorded in "KARAOKE" mode, press KARAOKE to go out the "KARAOKE" mode indicator (VOICE MUTE, L ONLY, R ONLY).

To record your voice:

1. Connect the microphone to the MIC jack.
2. Press REC PAUSE to put the cassette deck into the recording standby mode.
3. Press > or < to start recording.
4. Start "KARAOKE".

You cannot record in "KARAOKE" mode using:

- A tone quality effect (equalization curve, simulated listening environment, and V. BASS effect)
- A cassette tape originally made for KARAOKE use

You cannot use "KARAOKE" function with:

- A tone quality effect (equalization curve, simulated listening environment effect)
- A monaural source
- Recording with "KARAOKE" mode on a DCC tape.

(To be continued)

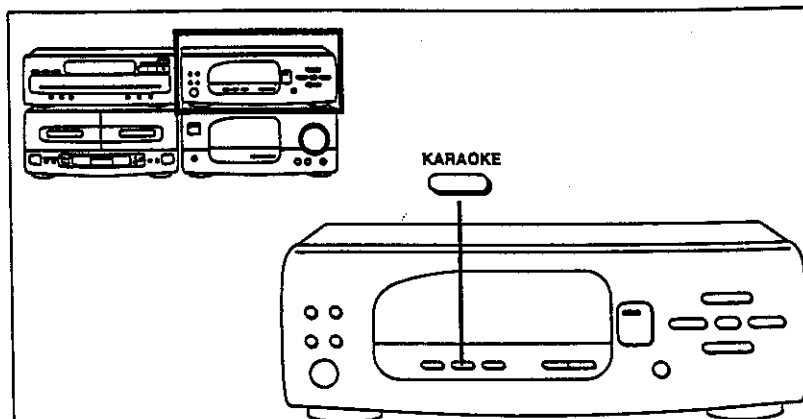

Enjoying the microphone mixing

(Continued)

Notes

- The KARAOKE mode cannot be activated when you select FM or MW or LW.
- During CD edit recording, you cannot alter the KARAOKE mode.
- This function may not be effective according to the type of music.
- If you hear strange noises (squealing or howling) during mixing, move the microphone farther away from the speakers or turn down the volume and microphone volume on the power amplifier.
- When you are not using the microphone, disconnect it from the MIC jack, and turn down the microphone volume level to MIN.
- Do not press KARAOKE when recording on a DCC or DAT.

Changing the display

Changing the output level display **A**

The display will change in 3 steps.
Select the desired display.

Press DISPLAY.

Each time you press DISPLAY, the display will change as shown in the illustration.

Note

You can change the output level scale only when the display shows same as ① and ②.

Changing the output level scale **B**

Change the output level scale of the source you are listening to.

Press RANGE.

Each time you press RANGE, the display will change as follows:

- ① Shows the output level scale, up to 60 W max.
When the output level scale is more than 60 W, "OVER" lights.
- ② Shows the output level scale, up to 6 W max.
When the output level scale is more than 6 W, "OVER" lights.

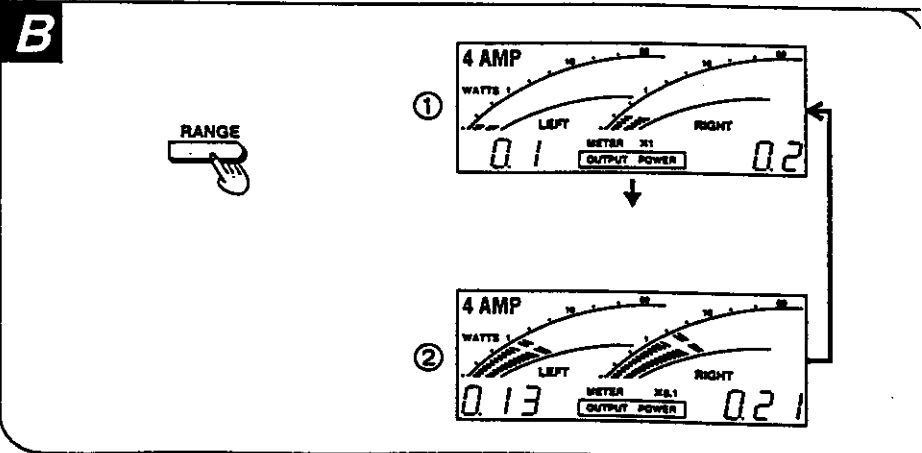
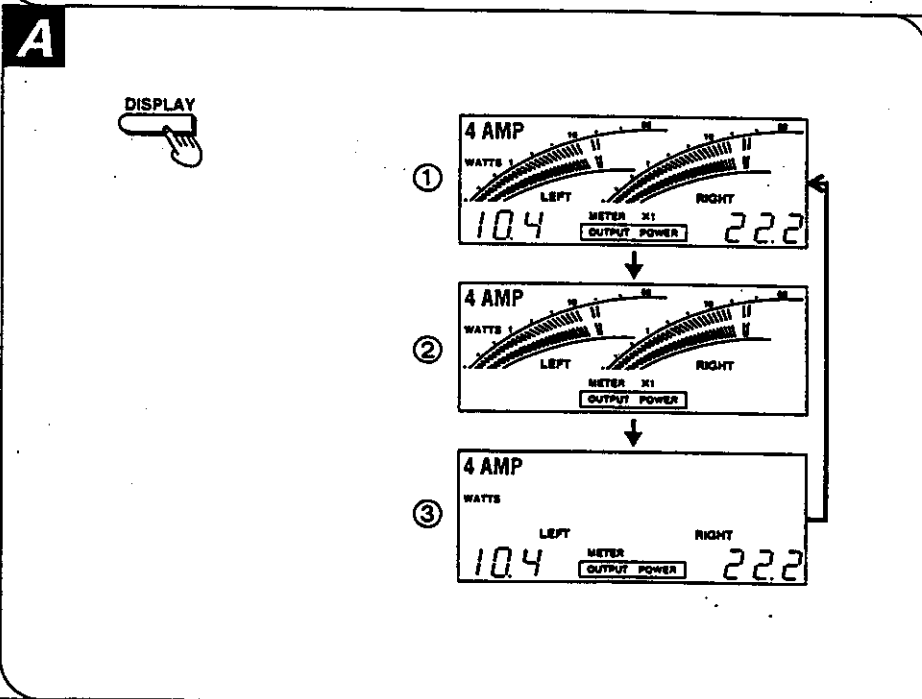
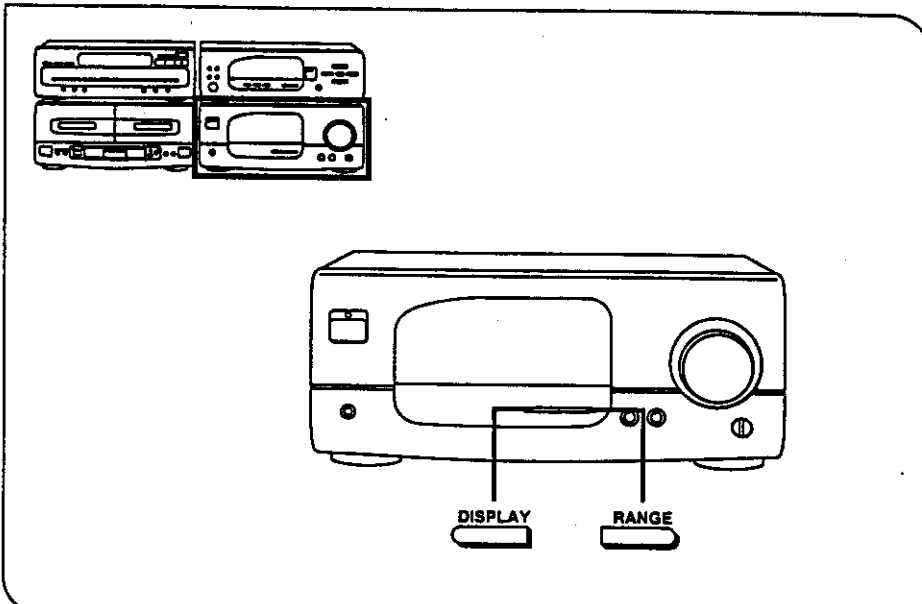

Using an external unit

Listening to an external source **A**

You can connect DCC (or DAT) or analog turntable to this system.

The following example shows when you select analog turntable.

- 1 Press EXT to select the external source.

Note

Each time you press EXT, "DCC" and "PHONO" will be alternately displayed.

- 2 Operate the unit which is connected to the system.
See the instruction manual of the unit concerned for the operation.

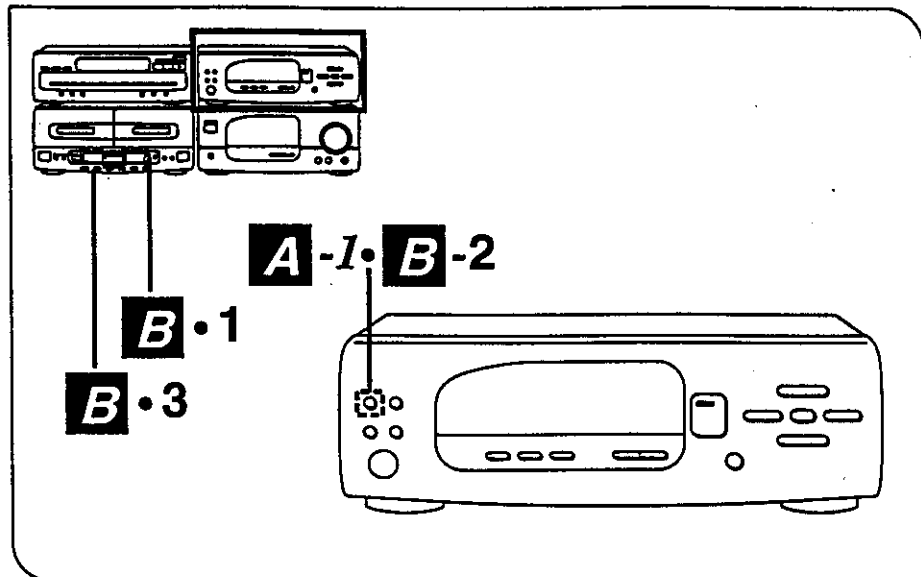

Recording from an external source **B**

The following example shows when you record from an analog player.

- 1 Press REC PAUSE on the cassette deck to put the cassette deck into the recording standby mode.
- 2 Press EXT to select the external source.
- 3 Press one of the playback buttons (▷ or ◁) on the cassette deck to start recording.
- 4 Start playing the source to be recorded.
See the instruction manual of the unit concerned for the operation.

(To be continued)

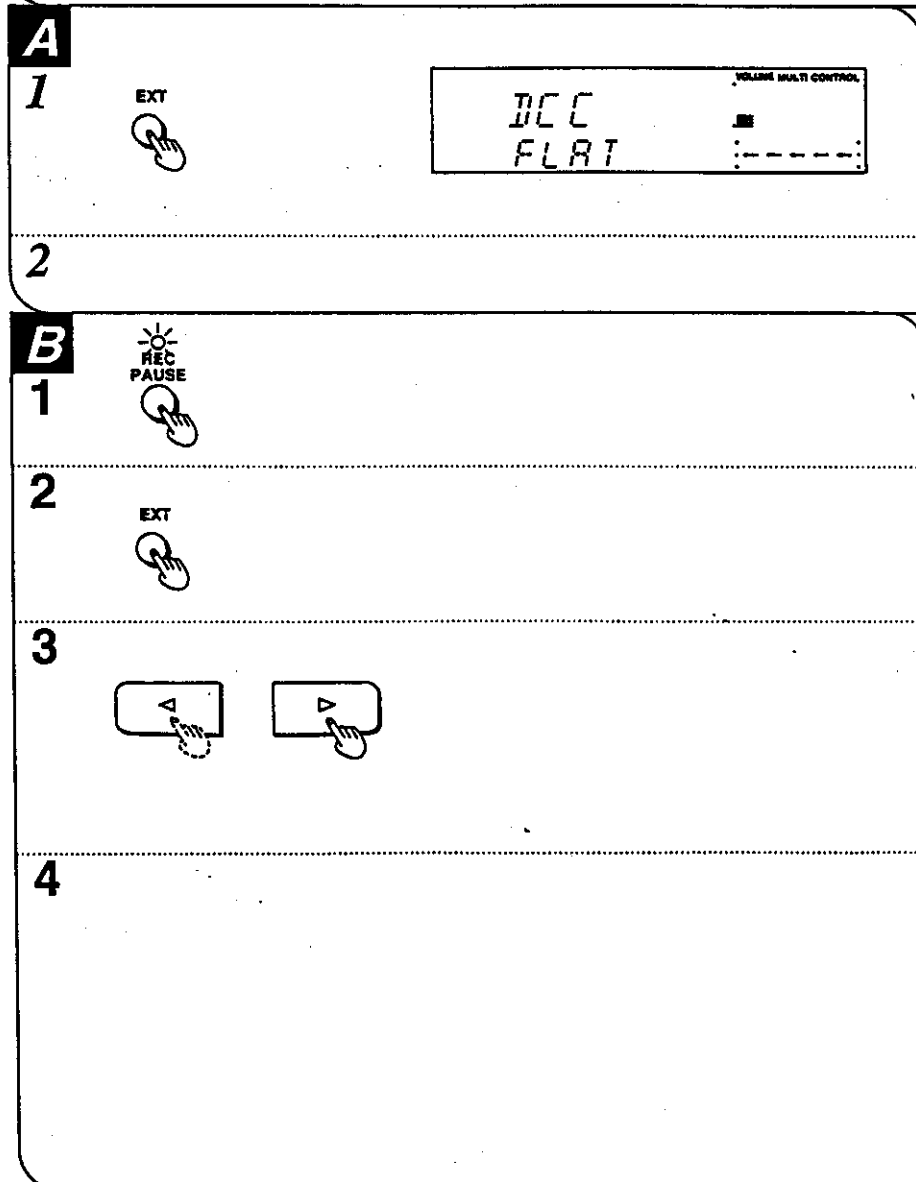

Using an external unit

(Continued)

To stop recording:

Press \square on the cassette deck.

To briefly interrupt recording:

Press REC PAUSE on the cassette deck.
The cassette deck will go into the recording standby state.

To resume recording:

Press one of the playback buttons (\triangleright or \triangleleft) corresponding to the direction in which recording is taking place.

To record on a DCC or DAT tape:

Start recording on a DCC or DAT, and then start playing the source to be recorded.
You cannot record the sound with the equalization curve, simulated listening environment, and V. BASS effect on a DCC or DAT tape.

Note



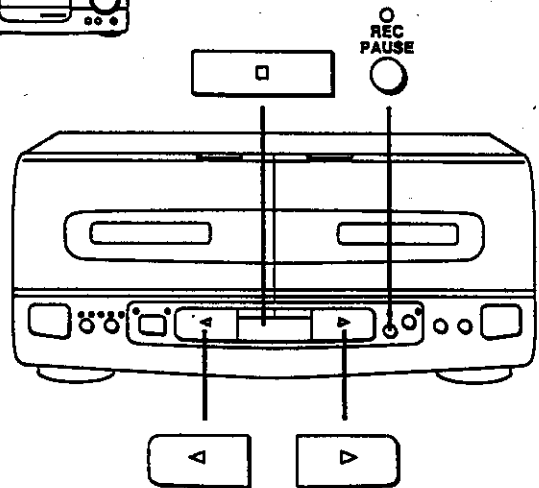
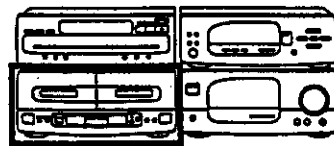



Do not press KARAOKE when recording on a DCC or DAT.

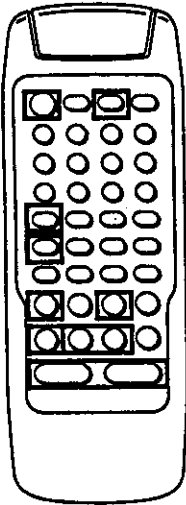

Quick reference of remote control operations
Referencia rápida de las operaciones del mando a distancia
遙控器操作

Common operation
Operaciones comunes
一般操作



Switching the system on and power standby mode Conexión y puesta en espera de la alimentación del sistema 打開本機並處於電源待命狀態	POWER 
Starting play directly from the power standby condition Inicio de la reproducción directamente desde el modo de alimentación en espera 直接從電源待命狀態開始放音	TUNELAND 
Selecting the input source Selección de la fuente de entrada 選擇輸入聲源	TUNELAND CD 
Adjusting the volume Ajuste del volumen 調節音量	- VOLUME + 
Adjusting the left-right volume balance Ajuste del equilibrio de volumen entre los canales derecho e izquierdo 調節左右音量平衡	L BALANCE R 
Muting the volume temporarily Silenciamiento temporal del volumen 暫時降低音量	MUTING 







(To be continued) (Continúa) (待續)

Quick reference of remote control operations

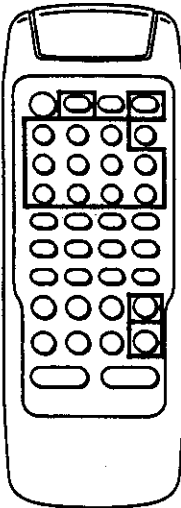
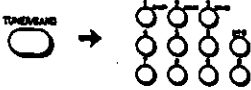
Referencia rápida de las operaciones del mando a distancia

遙控器操作

(Continued) (Continuación) (繼續)

		<i>Tuner/timer operation</i> <i>Operación de sintonizador/temporizador</i>	調諧器/定時器操作
	Listening to the radio broadcasts Escucha de radiodifusiones 欣賞收音機廣播		
	Switching between FM stereo mode and monaural Cambio entre sonido estéreo por FM y sonido mono 在 FM 立體聲方式和單聲道之間切換		
	Operating/releasing the sleep timer Operación/cancelación del temporizador para dormir 操作/清除睡眠定時器		
	<i>Tone control section</i> <i>Sección de control de tono</i> 音調控制部分		
	Switching between equalization curve and simulated listening environments Cambio entre curva de ecualización y ambientes de escucha simulados 均衡曲線和模擬欣賞環境的切換		
	Switching equalization curve or simulated listening environment on or off Activación o desactivación de la curva de ecualización o del ambiente de escucha simulado 均衡曲線和模擬欣賞環境的開關控制		
	Switching between PRESET and USER mode Cambio entre el modo PRESET y el modo USER PRESET (預編)和 USER (用戶)方式的 切换		Press and hold. Manténgalo pulsado. 按住

(To be continued) (Continúa) (待續)

Quick reference of remote control operations

Referencia rápida de las operaciones del mando a distancia

遙控器操作

(Continued) (繼續)
(Continuación)

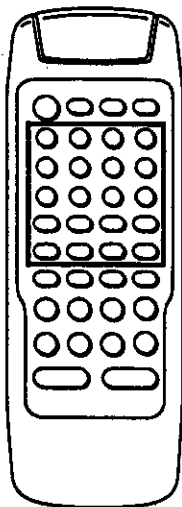

Compact disc section

Sección del reproductor de discos compactos

CD 部分

<p>Starting play Inicio de reproducción 開始放音</p>	
<p>Temporarily stopping play Parada temporal de la reproducción 暫時停止放音</p>	
<p>Stopping tracks Parada de la reproducción 停止放音</p>	
<p>Skipping tracks Salto de melodías 跳越曲目</p>	
<p>Starting play from a particular track Inicio de la reproducción desde una melodía particular 從指定的曲目開始放音</p>	
<p>Playing the particular track you programmed Reproducción de la melodía programada 播放您編排的指定曲目</p>	
<p>Cancelling the particular track you programmed Cancelación de la melodía programada 清除您編排的指定曲目</p>	

(To be continued) (待續)
(Continúa)

Quick reference of remote control operations

Referencia rápida de las operaciones del mando a distancia

遙控器操作

(Continued) (繼續)
(Continuación)

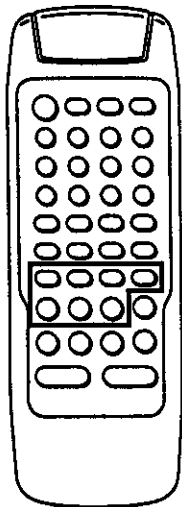

Tape section Sección de las platinas 磁帶部分

Switching between deck 1 and deck 2
Cambio entre la platina 1 y la 2
卡座 1 和卡座 2 的切换



Starting playback
Inicio de reproducción
開始放音



Finding the beginning of a track
Para encontrar el comienzo de una melodía
尋找曲目的開頭



During playback
Durante la reproducción
放音中

Fast forwarding or rewinding the tape
Avance rápido o rebobinado de la cinta
快進或倒轉磁帶



In stop mode
En el modo de parada
在停狀態下

Stopping playback
Parada de reproducción
停止放音



Recording
Grabación
錄音

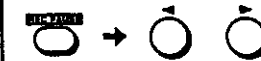

Concerning compact discs

To remove a disc from its case

A

Press the center holder and lift the disc holding by the edges.

To hold the disc

B

Hold the disc by the edges so the surface is not soiled with fingerprints.

Fingerprints, dirt and scratches can cause skipping and distortion.

To store a disc in its case

C

Insert the disc with label facing upwards and press downward at the center.

If the surface is soiled

D

Wipe gently with a soft, damp (water only) cloth.

If the disc is brought from a cold to a warm environment, moisture may form on the disc

Wipe this moisture off with a soft, dry, lint-free cloth before using the disc.

Improper disc storage:

You can damage discs if you store them in the following places:

- Areas exposed to direct sunlight
- Humid or dusty areas
- Areas directly exposed to a heat outlet or heating appliance

Handling precautions:

- Do not write on the label side with a ball-point pen or other writing utensils.
- Do not use record cleaning sprays, benzene, thinner, static electricity prevention liquids or any other solvent.
- Do not soil with fingerprints.



Only compact discs having this mark can be used with this unit.

En este aparato sólo podrán reproducirse los discos compactos que tengan esta marca.

本機僅可使用帶有此種標誌的激光唱片。

A

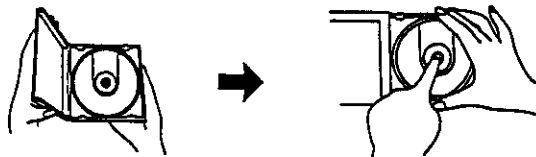

B



(Correct)
(Bien)
(正確)



(Incorrect)
(Mal)
(不正確)

C

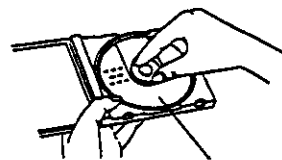

Label
Etiqueta
標籤面

D

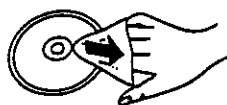

(Correct)
(Bien)
(正確)



(Incorrect)
(Mal)
(不正確)

Maintenance

Maintenance of external surfaces

To clean this unit, use a soft, dry cloth. If the surfaces are extremely dirty, use a soft cloth dipped in a soap-and-water solution or a weak detergent solution.

Wring the cloth well before wiping the unit. Wipe once again with a soft, dry cloth. Never use alcohol, paint thinner, benzene, or chemically treated cloths to clean this unit. Such chemicals may damage the finish of your system.

Tape head care **A**

To assure sound quality for recording and playback, be sure to clean the tape heads after approximately every 10 hours of use.

- 1 Press **POWER** on the amplifier to **ON**.
- 2 Press **▲ OPEN** to open the cassette holder.
- 3 Press **POWER** on the amplifier and **CLOSE** at the same time. The system will go into power standby mode leaving the cassette holder open.
- 4 Clean the tape heads, pinch rollers and the capstan shafts with a cotton swab (or a soft, lint-free cloth) slightly moistened with isopropyl alcohol. Do not use any solution other than alcohol for head cleaning.

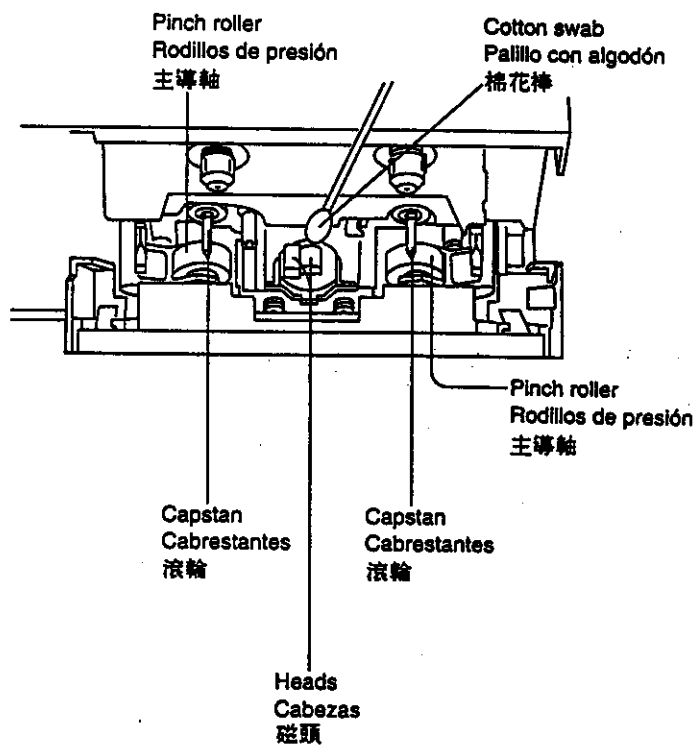

Concerning cassette tapes

Selection of cassette tapes

You can use normal, chrome, and metal tapes for recording:

- The deck automatically identifies the kind of tape loaded, and sets the bias (for recording) and equalization accordingly.
- The deck automatically sets the recording level.

Cassette tapes exceeding 90 minutes:

These tapes are handy for their long playback and recording time but be careful about repeatedly stopping and starting, rewinding and fast forwarding these tapes in short intervals as they are thin, tend to stretch and may become entangled in the deck mechanism.

Do not use the Fe-Cr tapes (TYPE III) in this system:

If you use this tape, it is impossible to obtain the required flat frequency response.

If the tape loosens, take up the slack **A**

Tape slack may cause the tape to break.

To prevent erasure of recorded sounds

Remove the erase-prevention tabs with a screwdriver or a similar object. **B**

To re-record on a protected cassette, cover the slot with adhesive tape. **C**

Do not cover the detection holes on chrome and metal tapes.

Improper tape storage:

You can damage tapes if you store them in the following places:

- In high temperature [35°C (95°F) or higher] or high humidity (80% or higher) areas
- In a strong magnetic field (near a speaker, on top of a TV, etc.)
This can erase a recording.
- Areas exposed to direct sunlight

A

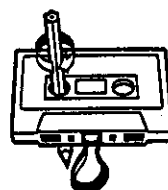

B

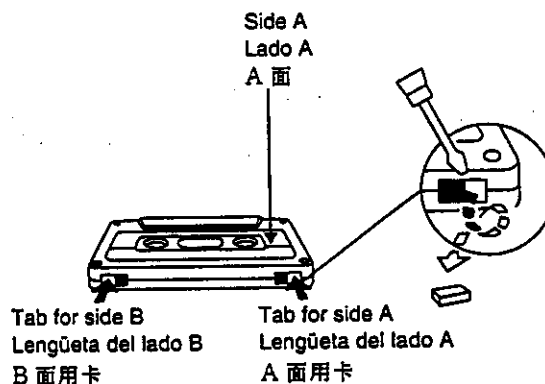

C

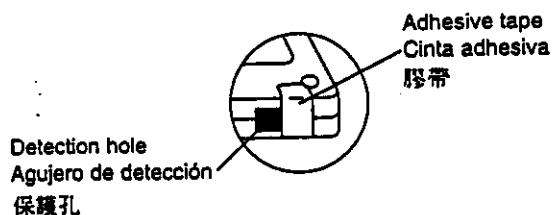

Troubleshooting guide

Before requesting service for this unit, check the chart below for a possible cause of the problem you are experiencing. Some simple checks or a minor adjustment on your part may eliminate the problem and restore proper operation.

If you are in doubt about some of the check points, or if the remedies indicated in the chart do not solve the problem, refer to the directory of Authorized Service Centers (enclosed with this unit) to locate a convenient service center, or consult your dealer for instructions.

Problem	Probable cause(s)	Suggested remedy
Problems common to all systems		
There is no sound when the power is ON.	Volume is set too low.	Adjust the volume level with the volume control on the amplifier.
The location of the various musical instruments is not well defined.	The (+) and (-) connections to one of the speakers are reversed.	Connect the speaker cord correctly.
The left and right sounds are reversed.	The left and right connections to the speaker are reversed.	Connect the speaker cords correctly.
When listening to the external unit, the left and right sounds are reversed.	The left and right connections to the external unit are reversed.	Connect the external unit's cord correctly.
Only one speaker is emitting sound.	One of the wires of the speaker cord is disconnected.	Connect the speaker cord correctly.
	The balance control is set to left or right.	Set the balance to the center position.
There is no sound when a source is being played.	The (+) and (-) wire of the speaker cords are shorted.	Switch the system to the standby mode, and reconnect the speaker cords so that they are not shorted. Then switch on the power.
"U70" display appears on the compact disc changer or tuner/sound processor display.	Flat cables are not connected steadily.	Connect the flat cables steadily.
"F65" display appears on the amplifier display.	Malfunction might occur in this unit.	Contact with your dealer or an Authorized Service Center.

While listening to FM broadcasts

There is a "rushing noise" during a stereo broadcast which is not audible during a monaural broadcast.	The transmitting station is a long distance away.	<ul style="list-style-type: none"> ● If you are using an indoor antenna, change to an outdoor antenna. ● If you are using a high-grade outdoor antenna, try changing the installation location, height, and orientation.
You hear excessive noise during a stereo broadcast, and occasionally the sound disappears.	The installation location and orientation of the antenna are unsuitable.	
The stereo indicator flickers and does not light completely.	The transmitting station is a long distance away.	Try switching off the TV set or VCR.
	The power of the TV set or VCR is ON.	
The sound during a stereo broadcast is highly distorted.	There is a building or mountain nearby. [Distortion is caused by interference between the signal from the transmitting station (direct wave) and the signal reflected from the building or mountain (reflected wave).]	Use a high-grade outdoor antenna, and install it in a good location, height, and orientation for reception.

(To be continued)

Troubleshooting guide

(Continued)

Problem	Probable cause(s)	Suggested remedy
---------	-------------------	------------------

While listening to MW/LW broadcasts

You hear an unusual beat sound.	You are using the system at the same time you are playing a TV set.	Switch off the TV set, or use the system further away from it.
You hear a low-frequency hum.	The antenna wire is near the power cord.	Separate the antenna wire from the power cord.

When there is a television set nearby

The picture on the TV disappears or stripes appear on the screen.	The location and orientation of the antenna are incorrect.	If you are using an indoor antenna, change to an outdoor antenna.
	The wiring at the back of the system is unsuitable.	Separate the antenna wire of the TV set from the system.

While listening to tapes

Sound is low, intermittent, or poor quality, noisy, scratchy, or unsteady.	Heads are dirty.	Clean the heads.
	Dolby noise reductions is set in the wrong position.	Set it to match the Dolby NR recording mode.
The deck does not enter the recording mode.	The erase-prevention tabs are removed from the cassette.	Attach tape to cover the space left by removal of the erase-prevention tabs.

While listening to compact discs

The display will not show the correct indication. Disc play does not start when you press the play button.	The disc is not positioned correctly in the disc tray.	Load the disc on the tray correctly.
	The disc is loaded upside down.	Reload the disc.
	The disc is dirty.	Wipe the disc with a soft cloth.
	The disc is scratched.	Replace the disc with a new one.
	The disc is badly warped.	
	The disc is a nonstandard one.	Replace the disc with a different one.
	There is condensation inside the disc player.	Switch the power ON, and then wait for 60 minutes before using the disc player.

While using the remote control

The system cannot be operated with the remote control.	The batteries are installed in the reverse polarity.	Re-insert the batteries in the correct polarity.
	The batteries are worn.	Replace the batteries with new batteries.

The servicer will require all components to service your system. Therefore, should service ever be necessary, be sure to bring the entire system.

Technical specifications

TUNER/SOUND PROCESSOR

■ Pre-amplifier section

Input sensitivity/Impedance

AUX	250 mV/15 kΩ
DCC	250 mV/15 kΩ

Output level

DCC RECOUT	150 mV/1.5 kΩ
------------	---------------

Frequency response

AUX	30 Hz–20 kHz
DCC	30 Hz–20 kHz

■ EQ, SFP section

Center frequency

80, 250, 1 k, 4 k, 12.5 k(Hz)

Fixed mode

SPACE	3 modes (DISCO, LIVE, HALL)
GEQ	5 modes (HEAVY, CLEAR, SOFT, CAR, HP ST)

Mic echo

(For areas except Australia and
New Zealand) 1.0–1.6 sec

■ FM tuner section

Frequency range 87.50–108.00 MHz
(0.05 MHz steps)

Sensitivity 1.8 μV (IHF usable)

S/N 26 dB 1.5 μV

S/N MONO 70 dB (75 dB, IHF)

Stereo separation at 1 kHz 35 dB

Antenna terminal(s) 75Ω (unbalance)

■ AM tuner section

Frequency range

MW 522–1611 kHz (9 kHz steps)
530–1620 kHz (10 kHz steps)

LW 144–288 kHz (9 kHz steps)

Sensitivity (S/N 20 dB)

MW 500 μV/m

LW 50 μV

■ Timer section

Clock Quartz-lock type

Function 24-hour programmable;

Play timer (1 time), Rec timer (1 time),

Sleep (120 min., 1 min. intervals)

Setting 1 minute–23 hours 59 minutes
(1 min. intervals)

■ General

Dimensions (W×H×D)

270×89×274 mm

Weight

1.75 kg

AMPLIFIER

Power output

DIN 1 kHz, THD 1%, both channels
driven 2×60 W (6Ω)

Total harmonic distortion

Rated power at 1 kHz 1% (6Ω)

Half power at 1 kHz 0.09% (6Ω)

Load impedance

MAIN 6–8Ω

SURROUND 8Ω

S/N (rated power)

84 dB

■ General

Power consumption 198 W

Power supply

(For Australia and New Zealand)

230–240 V, AC 50/60 Hz

(For others)

110/127/220/240 V, AC 50/60 Hz

Dimensions (W×H×D)

270×118.5×335 mm

Weight

5.7 kg

CD CHANGER

■ Audio

DA converter 1 bit 2 DAC MASH

■ CD Graphics

Video format

(For areas except Australia and
New Zealand)

NTSC (M)/PAL (B, D, G, H, I)

■ Pickup

Wavelength

780 nm

■ General

Dimensions (W×H×D)

270×89×320 mm

Weight

2.9 kg

CASSETTE DECK

Deck system Stereo cassette deck

Track system 4 track, 2 channel

Recording system AC bias

Bias frequency 80 kHz

Erasing system AC erase

Heads

Deck 1

(Playback head) Permalloy head

Deck 2

(Recording/Playback head)

Permalloy head

(Erasing head)

Double gap ferrite head

Motors

Decks 1, 2

(Capstan drive)

DC servo motor

(Reel table drive)

DC motor

Tape speed 4.8 cm/sec

Wow and flutter 0.1% (WRMS)

Fast forward and rewind times

Approx. 45 seconds

with C-60 cassette tape

Frequency response

(Dolby NR off, CCRT on)

NORMAL 20 Hz–17 kHz

30 Hz–15 kHz (+0 dB, –7 dB, DIN)

CrO₂ 20 Hz–18 kHz

30 Hz–17 kHz (+0 dB, –7 dB, DIN)

METAL 20 Hz–20 kHz

30 Hz–19 kHz (+0 dB, –7 dB, DIN)

S/N (Signal level=max recording level,
CrO₂)

NR off 56 dB (A weighted)

Dolby B NR on 66 dB (CCIR)

Dolby C NR on 74 dB (CCIR)

Input sensitivity and Impedance

LINE IN 126 mV/17.6 kΩ

Output voltage and Impedance

LINE OUT 400 mV/220Ω

■ General

Dimensions (W×H×D)

270×118.5×263 mm

Weight

2.85 kg

SPEAKER SYSTEM

Type 3 way/surround speaker system

Speaker(s)

Woofer

20 cm active air coupling woofer;

20 cm passive radiator;

17 cm cone type driver unit

Main unit

8 cm cone type

Tweeter

Dome type

Full range

8 cm cone type

Impedance

MAIN

6Ω

SURROUND

8Ω

Input power

MAIN

140 W (music), 70 W (DIN)

SURROUND

24 W (music), 12 W (DIN)

Output sound pressure level

81 dB/W (1.0 m)

Cross over frequency 160 Hz, 10 kHz

Frequency range

28 Hz–22 kHz (–16 dB)

■ General

Dimensions (W×H×D)

239×414.5×326 mm

Weight

6.2 kg

Notes:

- Specifications are subject to change without notice. Weight and dimensions are approximate.
- Total harmonic distortion is measured by the digital spectrum analyzer.

MASH is a trademark of NTT.

Free Manuals Download Website

<http://myh66.com>

<http://usermanuals.us>

<http://www.somanuals.com>

<http://www.4manuals.cc>

<http://www.manual-lib.com>

<http://www.404manual.com>

<http://www.luxmanual.com>

<http://aubethermostatmanual.com>

Golf course search by state

<http://golfingnear.com>

Email search by domain

<http://emailbydomain.com>

Auto manuals search

<http://auto.somanuals.com>

TV manuals search

<http://tv.somanuals.com>