

POWER SPORT™

Operator's Manual

LH318EA (HM80-90)

LH358EA (HM100)

OH195EA/OH195EP

OH318EA

Four-Cycle Engine • Horizontal Crankshaft • Air-Cooled

Table of Contents

IMPORTANT NOTICE! Safety Definitions	ii
I. General Safety Precautions	1
II. How to Get Service	4
III. Oil and Fuel Specifications	5
IV. Before Starting Your Engine	6
V. Starting Your Engine	10
VI. Stopping Your Engine and Short-Term Storage	18
VII. Transporting Your Recreational Vehicle	18
VIII. Maintenance	18
IX. Storing Your Engine	25
X. Preventing Forest, Brush and Grass Fires	27
XI. Maintenance Intervals	28
California & US EPA Emission Control Warranty Statement	36
Emission Control System Warranty	37
XII. Warranty Information	38

Visit our web site at www.TecumsehPower.com

- ◆ Register Your Tecumseh Engine
- ◆ Maintenance Tips
- ◆ Parts Look-Up System
- ◆ Great Tecumseh Apparel
- ◆ Nearest Authorized Tecumseh Servicing Dealer Location

LOG ON!

181-1269-14
(English) 1/01/08

I. Safety Definitions

Statements in this manual preceded by the following words and graphics are of special significance:

WARNING

Or

WARNING

WARNING indicates a potentially hazardous situation which if not avoided, could result in death or serious injury.

CAUTION

Indicates a potential situation which if not avoided, could result in equipment or property damage.

NOTE

Refers to important information and is placed in italic type.

It is recommended that you take special notice of all items discussed on the next three pages and wear the appropriate safety equipment.

Before operating this engine *it is your responsibility* to read this Operator's Manual. Follow these basic rules for your personal safety:

- Keep this manual handy at all times for future reference.
- Read it carefully and familiarize yourself with operating, maintenance, components and safety instructions.

II. Notice Regarding Emissions

NOTE

Engines which are certified to comply with California and U.S. EPA emission regulations for SORE (Small Off Road Equipment), are certified to operate on regular unleaded gasoline, and include the following emission control systems: (EM) Engine Modification and (TWC) Three-way Catalyst (if so equipped).

III. Tecumseh Contact Information

For engine adjustments, repairs or warranty service not covered in this manual, contact your nearest Authorized Tecumseh Servicing Dealer. Find them on our website at www.TecumsehPower.com or call Tecumseh Power Company at 1-800-558-5402.

The trademarks TECUMSEH® and the DESIGN (Native American Head logo) are registered trademarks of Tecumseh Products Company and are used by Tecumseh Power Company under license from Tecumseh Products Company. Tecumseh Power Company is no longer owned by Tecumseh Products Company nor is it associated or affiliated in any way with Tecumseh Products Company.

©Copyright 2006
Tecumseh Power Company
All Rights Reserved

I. Use this Engine Only in Approved Applications

Tecumseh Powersport engines are designed specifically for non-competitive recreational vehicle applications such as fun-karts, mini-bikes and ATV's. This engine is not designed or approved for aircraft, go-peds or any racing applications. Since not all applications of this engine can be anticipated, contact your nearest Authorized Tecumseh Servicing Dealer. Find them on our website at www.TecumsehPower.com or call Tecumseh Power Company at 1-800-558-5402 for more information or if you have questions about a particular application.

WARNING

Use of this Power Sport engine in non-approved applications may lead to serious injury or death.

II. Special Information for Users Installing an Engine

WARNING

If you purchased this engine separately with the intention of installing it on a recreational vehicle, ensure that the vehicle is designed or is retrofitted to be used specifically with this Tecumseh Power Sport engine. If you use an improper, non-approved and/or wrong sized engine, there is a potential for serious injury or death from:

- operation at unsafe speeds or a runaway vehicle,
- improper fit and operation of guards, electrical wiring, throttle cable, clutch, torque converter, etc.

III. Engine Model Applications

This manual applies to the following Power Sport Engine Models:

- LH318EA (HM80-90), LH358EA (HM100)
- OH195EA/OH195EP
- OH318EA

I. General Safety Precautions

WARNING

Read equipment manufacturer's manual and this material thoroughly before using this engine. Failure to do so can result in serious injury or death. Call Tecumseh Power Company at 1-800-558-5402 or visit www.TecumsehPower.com if you have any questions.

A. Avoid Carbon Monoxide Poisoning

All engine exhaust contains carbon monoxide, a deadly gas. Breathing carbon monoxide can cause headaches, dizziness, drowsiness, nausea, confusion and eventually death.

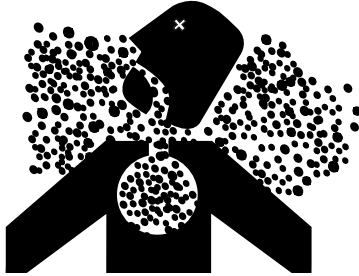

Carbon monoxide is a colorless, odorless, tasteless gas which may be present even if you do not see or smell any engine exhaust. Deadly levels of carbon monoxide can collect rapidly and you can quickly be overcome and unable to save yourself. Also, deadly levels of carbon monoxide can linger for hours or days in enclosed or poorly-ventilated areas. If you experience any symptoms of carbon monoxide poisoning, leave the area immediately, get fresh air, and **SEEK MEDICAL TREATMENT**.

To prevent serious injury or death from carbon monoxide:

- NEVER run engine indoors. Even if you try to ventilate engine exhaust with fans or open windows and doors, carbon monoxide can rapidly reach dangerous levels.
- NEVER run engine in poorly-ventilated or partially enclosed areas such as barns, garages, basements, carports, under dwellings, or in pits.
- NEVER run engine outdoors where engine exhaust can be drawn into a building through openings such as windows and doors.

B. Avoid Gasoline Fires

Gasoline (fuel) vapors are highly flammable and can explode. Fuel vapors can spread and be ignited by a spark or flame many feet away from engine. To prevent injury or death from fuel fires, follow these instructions:



- NEVER store engine with fuel in fuel tank inside a building with potential sources of ignition such as hot water and space heaters, clothes dryers, electric motors, etc.
- NEVER add fuel with engine running.
- NEVER start or operate the engine with the fuel fill cap removed.
- Allow engine to cool before refueling.
- NEVER fill fuel tank indoors or in an enclosed area such as a garage, barn shed, etc. Fill fuel tank outdoors in a well-ventilated area.
- DO NOT smoke while refueling tank.
- Use only an approved red GASOLINE container to store and dispense fuel. Tecumseh recommends purchasing gasoline in containers with a capacity of 2.5 gallons or less. Small containers are easier to handle and help eliminate spillage during refueling.
- DO NOT pour fuel from engine or siphon fuel by mouth. To empty the fuel tank see "I. Draining Fuel" instructions on page 26.

C. Adult Supervision of Operation, Refueling and Maintenance

The manufacturer of the recreational vehicle may provide information about who is allowed to operate or ride in the vehicle (see equipment manufacturer's manual). Not everyone who is allowed to operate or ride in the vehicle is capable of safely and responsibly operating, maintaining and/or fueling this Tecumseh Power Sport Engine. Tecumseh recommends the following:

- An adult should fuel this engine. NEVER allow children to refuel this engine. See "D. Filling Fuel Tank" instructions on page 8.
- An adult should perform maintenance on this engine. See "VIII. Maintenance" instructions on page 18. Only allow children to perform maintenance if an adult has determined they are experienced and capable of such operation.
- An adult should start the engine. See "G. Avoid Accidental Starts" instructions on page 3 and "A. Engine Pre-Ride Checklist" instructions on page 6. Only allow children to start the engine if an adult has determined they are experienced and capable of such operation.

To avoid unsupervised operation of the recreational vehicle, especially by children, NEVER leave the engine unattended when it is running.

D. Stay Away from Rotating Parts

NEVER operate the engine with an unguarded engine shaft. See Figure 1.

The equipment manufacturer attaches a sprocket and chain or pulley and belt to the engine shaft. If these parts are not properly guarded, or if you are not sure whether they are properly guarded, DO NOT use your recreational vehicle; contact the equipment manufacturer. Hands, feet, hair, jewelry, clothing, etc. can become entangled in rotating parts, leading to serious injury or death. To avoid serious injury or death, be sure the flywheel guard is in place. See Figure 2.

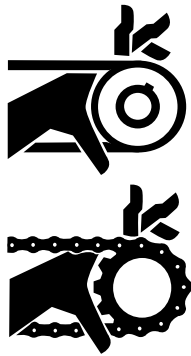

E. Do Not Modify Engine

To avoid serious injury or death, DO NOT modify engine in any way. Tampering with the governor setting can lead to a runaway vehicle and cause the engine to operate at unsafe speeds. NEVER tamper with factory setting of engine governor.

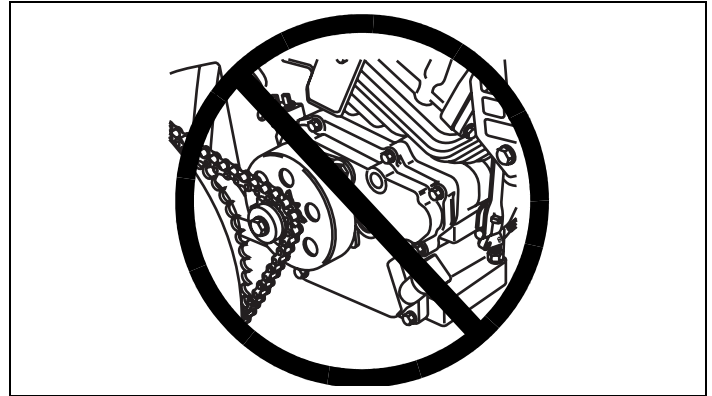

Figure 1. DO NOT use Without Engine Shaft Guard

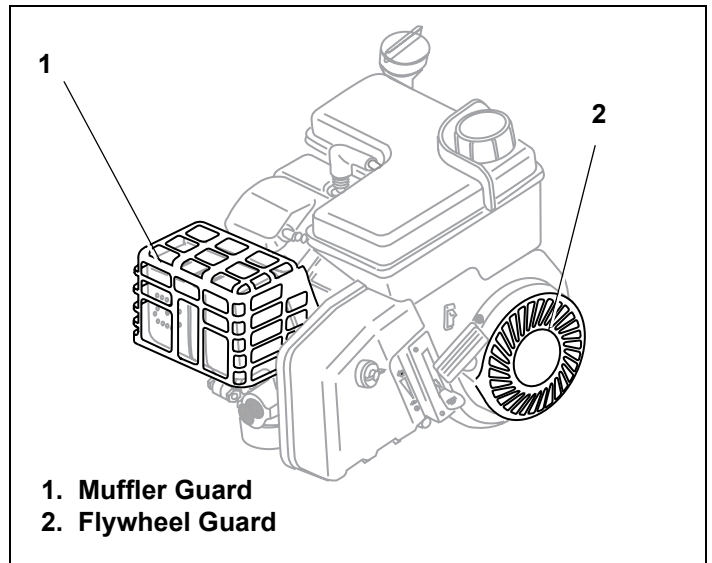

Figure 2. Typical Engine Guard Locations

F. Avoid Burns and Fire from Hot Surfaces

The muffler and other engine parts become extremely hot during operation and remain hot after the engine has stopped.

- To avoid severe burns on contact, NEVER operate the engine without the muffler guard in place, see Figure 2 and avoid hot areas of the engine.
- To reduce the risk of fire keep all materials that can burn, including grass and leaves, away from muffler and rest of engine. DO NOT operate, idle or park the recreational vehicle in long dry grass or other dry ground cover.



G. Avoid Accidental Starts

To prevent accidental starting when working on equipment always:

- Disconnect spark plug wire and keep it away from spark plug. See Figure 3.
 - Keep the disconnected spark plug wire securely away from metal parts where arcing could occur.
 - Attach the spark plug wire to the grounding post, if provided. See Figure 4.
- Disconnect battery at negative terminal first, if engine is equipped with an electric starter.
- Turn off all engine switches.
- Remove ignition key, if provided.

H. Use Hearing Protection

Engine noise may cause hearing damage. Always wear hearing protection when operating a recreational vehicle engine.

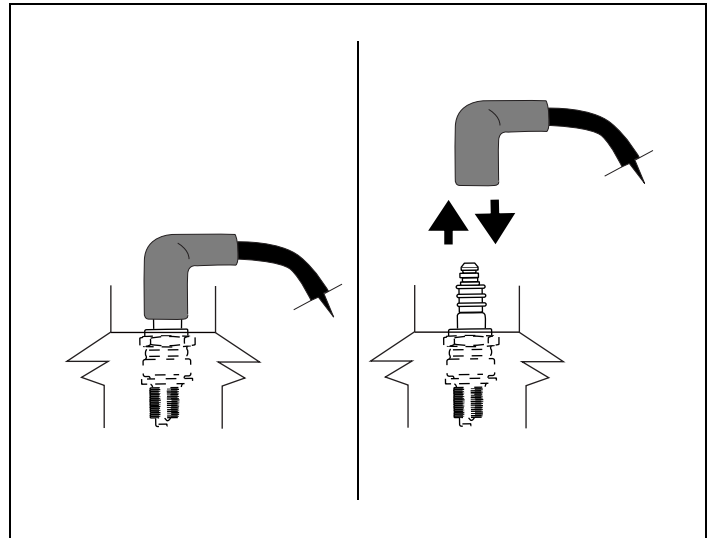

Figure 3. Disconnecting/Connecting Spark Plug

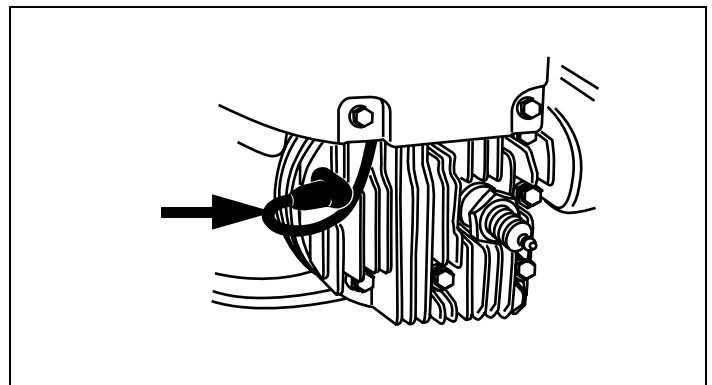

Figure 4. Spark Plug Grounding Post

II. How to Get Service

For engine adjustments, repairs or warranty service not covered in this manual, contact your nearest Authorized Tecumseh Servicing Dealer. Find them on our website at www.TecumsehPower.com or call Tecumseh Power Company at 1-800-558-5402.

Visit our web site at www.TecumsehPower.com

- ◆ Register Your Tecumseh Engine
- ◆ Maintenance Tips
- ◆ Parts Look-Up System
- ◆ Great Tecumseh Apparel
- ◆ Nearest Authorized Tecumseh Servicing Dealer Location

LOG ON!

A. Engine Identification Decal

A sample decal located on your engine indicates your engine's model number, specification and the date of manufacture (D.O.M.). Please look at the decal on your engine and fill in this information in the spaces provided for future reference. See Figure 5.

The Engine Identification Decal includes engine life specifications for the emissions-related useful life period of your engine. This period relates to the emission compliance life as certified by EPA and/or CARB. To find the life period specification for your engine, please look on your decal and find the letter enclosed by quotation marks between the words MODERATE and LIFE PERIOD. Match one of the following letters with the letter printed on your decal. For example, OH195EA/OH195EP models are designated as "C" 125 hours, "B" 250 hours and "A" 500 hours. LH318EA (HM80-90), LH358EA (HM100) and OH318EA models are designated as "C" 250 hours, "B" 500 hours and "A" 1000 hours.

B. Tecumseh Technician's Handbooks

If you have a general understanding of internal combustion engines and wish to repair and service your engine and/or engine emission control systems yourself, a Technician's Handbook is available from your Authorized Tecumseh Servicing Dealer. See Figure 6. This handbook covers repairs and adjustments not covered within this Operator's Manual, and it is intended for individuals who have had adequate training, experience and who practice proper tool usage. Service procedures should be clearly understood and practiced when servicing Tecumseh Power Sport Engines. Order as part no. 695244A for OH195EA/OH195EP and OH318EA models. Order as part no. 692509 for LH318EA (HM80-90), LH358EA (HM100) models.

Tecumseh manufactures and is responsible only for the engine used on this power equipment. If repair or service is needed for anything other than the engine, contact the service source recommended by the equipment manufacturer.

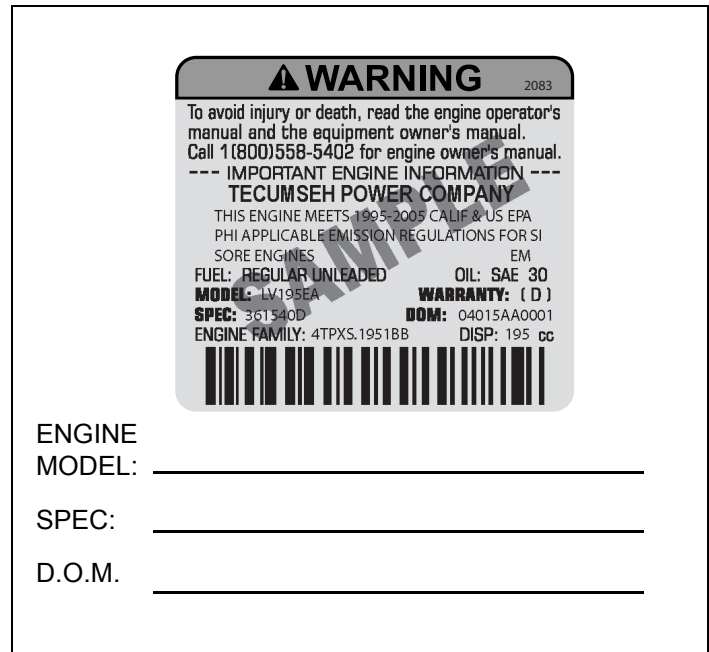

Figure 5. Engine Identification Label

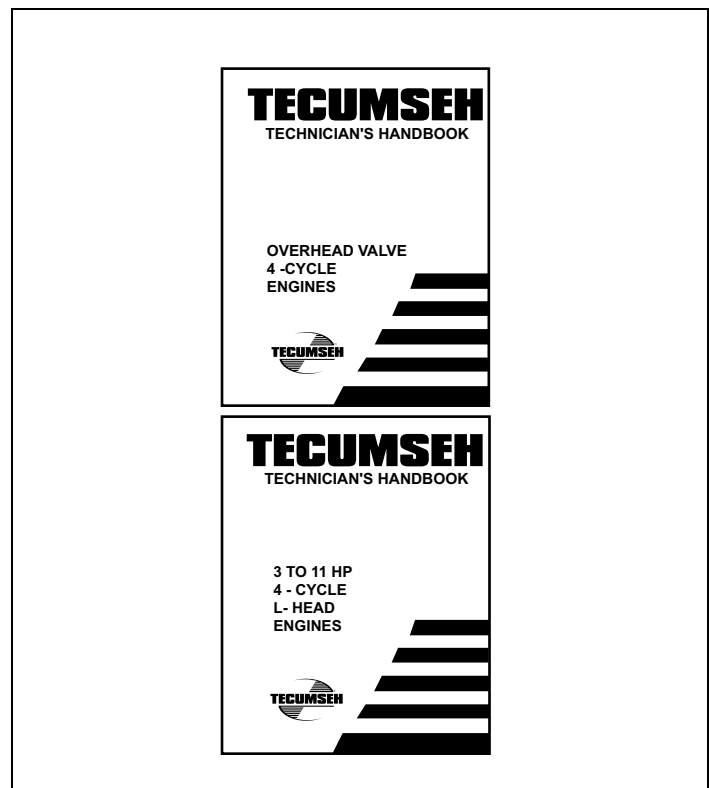

Figure 6. Technician Handbooks

III. Oil and Fuel Specifications

A. Oil

To operate engine you need to use a clean, high quality, detergent oil. For recommended engine oil, See Table 1.

NOTES

Be sure oil container is marked A.P.I. Service "SL/SJ".

Using multigrade oil above 32° F (0° C) will increase oil consumption. SAE10W40 is not recommended.

Oil sump capacities vary with each model. Tecumseh special-formulated oils are available at your Authorized Tecumseh Servicing Dealer. See Table 2.

Table 1. Recommended Engine Oil

Tecumseh Recommended Oil Usage											
						Straight Grade Tecumseh Part No. 730225A or SAE 30					
				Multi Grade Tecumseh Part No. 730226A or SAE 5W30 or SAE 10							
						Synthetic Tecumseh Part No. 730263 or SAE 0W30					
	-20°F	0°F	20°F	32°F	40°F	60°F	80°F	100°F			
	-30°C	-20°C	-10°C	0°C	10°C	20°C	30°C	40°C			

B. Fuel

Use unleaded regular, unleaded premium or reformulated automotive fuel only. You may use gasoline containing the following components identified. See Table 3.

- DO NOT use leaded fuel.
- Fuel must be fresh and clean. NEVER use fuel left over from last season or stored for long periods.
- NEVER mix oil with fuel.
- DO NOT use fuel containing Methanol (Wood Alcohol).

CAUTION

The use of alternative fuels such as E85 or E20 are not recommended for use in Tecumseh engines. Alternative fuels with high alcohol content can cause hard starting, poor engine performance, and may cause internal engine damage.

NOTE

Damage and/or performance problems that will occur from use of fuels, other than those listed in the Operator's Manuals will not be considered warranty.

Table 2. Oil Sump Capacities

Engine Model	Units		
	Ounces	U.S. Pints	Liters
Application			
LH318EA (HM80-90) LH358EA (HM100)	26 oz.	1-5/8	.78
OH195EA/OH195EP	21 oz.	1-1/4	.62
OH318EA	26 oz.	1-5/8	.78

Table 3. Recommended Fuel Components

Fuel Component	Percentage
Ethanol	10%
Grain Alcohol ("Gasohol")	10%
MTBE (Methyl Tertiary Butyl Ether)	15%
ETBE (Ethyl Tertiary Butyl Ether)	15%

IV. Before Starting Your Engine

A. Engine Pre-Ride Checklist

WARNING To avoid serious injury or death, always complete both the engine and equipment manufacturer's pre-ride checklist before using the engine. This engine should NEVER be used if you identify a problem with any of the steps listed below.

Be sure the engine is turned off for steps 1 thru 4:

1. Fuel cap—Check that the anti-splash fuel fill cap is securely in place.
2. Guards—Check that all of the guards are securely in place. NEVER operate the vehicle if you think there may be a guard missing. Check with equipment manufacturer for a complete list of guards. See Figure 7 and Figure 8. See "D. Stay Away from Rotating Parts" instructions on page 2.
3. Debris—Check that engine, controls and guards are free from debris, snow or ice. For debris removal areas, see "B. Removing Debris From Engine" instructions on page 20.
4. Throttle—With the engine off, check that the gas pedal operates smoothly and returns to an idle position when released.

WARNING An adult should start the engine. Only allow children to start engine if an adult has determined they are experienced and capable of such operation.

5. Idle speed—Be sure that operator is in place with the brake engaged before starting the engine. Start the engine and slowly release the brake. Check that the vehicle does not move when the engine is idling. If it does move at idle, stop the vehicle and shut off the engine. The vehicle requires service and should not be operated.
6. Engine stop switches—Check that the operator knows where all engine stop switches are located. Check that all engine stop switches immediately stop the engine. For stop switch locations, see Figure 13 on page 8.

For questions about the pre-ride checklist for this engine, contact your nearest Authorized Tecumseh Servicing Dealer. Find them on our website at www.TecumsehPower.com or call Tecumseh Power Company at 1-800-558-5402.

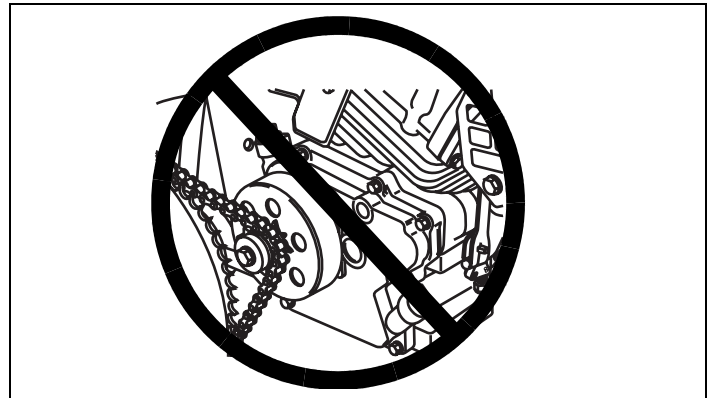

Figure 7. Incorrect Usage Without Engine Shaft Guard

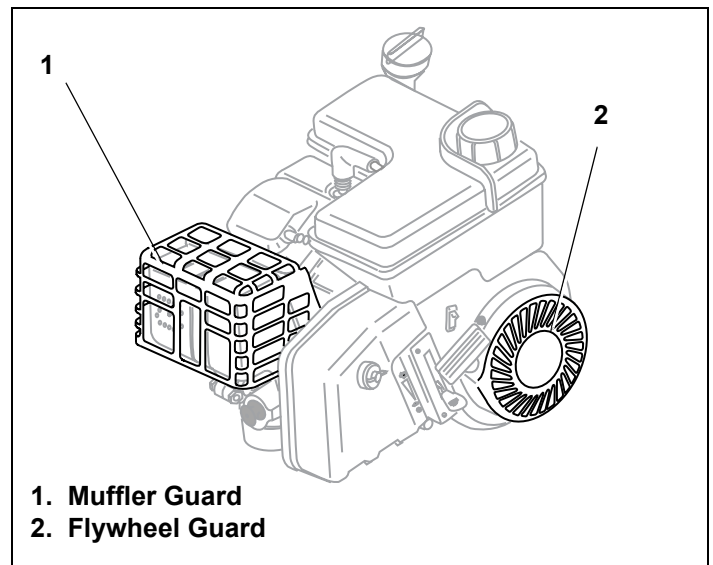

Figure 8. Engine Guard Locations

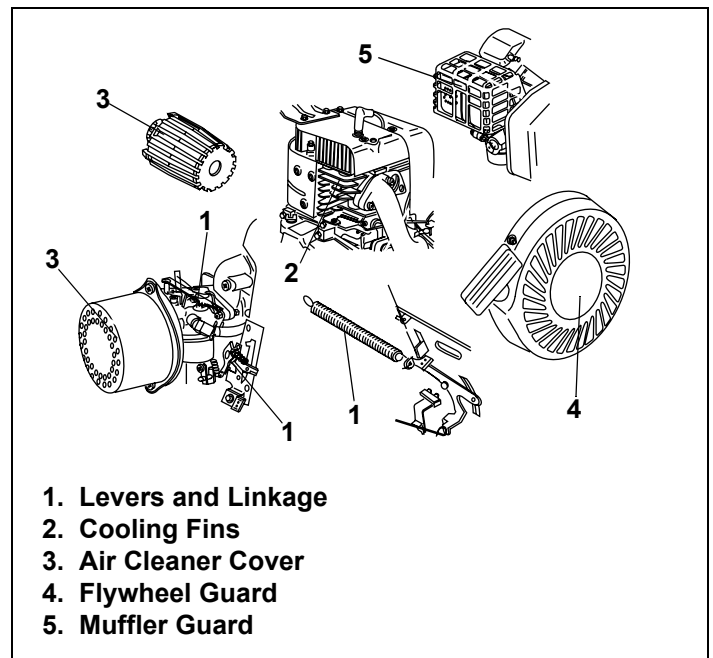

Figure 9. Debris Removal Areas

B. Checking Oil Level

To avoid engine damage, it is important to:

- Check oil level before each use and every 5 operating hours.
- Keep oil level between “FULL” and “ADD” marks on dipstick or to point of overflow on engines without dipstick. See Figure 10.
- Be sure oil fill dipstick/plug is tightened securely.

NOTES

Do not overfill engine with oil. Doing so may result in equipment malfunction or damage.

Do not allow oil level to fall below the “ADD” mark on dipstick. Doing so may result in equipment malfunction or damage.

Contact your Authorized Tecumseh Servicing Dealer for Tecumseh Oil.

I. Oil Fill Dipstick

If your engine has an oil fill plug see "II. Oil Fill Cap Without Dipstick (Oil fill Plug)" instructions.

1. Be sure engine is upright and level.

NOTE

Some Power Sport Engines are equipped with an oil fill dipstick. See Figure 11.

2. Unscrew oil fill dipstick from oil filler tube and wipe clean.
3. Screw oil fill dipstick back into oil filler tube. Tighten securely.
4. Unscrew and remove oil fill dipstick from oil filler tube. Note oil level. If oil reading on dipstick is below “ADD” mark, slowly add oil to reach “FULL” level. See Figure 10.
5. Screw oil fill dipstick back into oil filler tube. Tighten securely.
6. Wipe away any spilled oil.

II. Oil Fill Cap Without Dipstick (Oil fill Plug)

If your engine has an oil fill dipstick see "I. Oil Fill Dipstick" instructions.

1. Be sure engine is upright and level.

NOTE

All models in this manual may be equipped with optional oil fill plug locations. See Figure 12.

2. Clean area around oil fill plug(s). See Figure 12.
3. Unscrew oil fill plug.
4. Add oil to overflow point, making sure to avoid spilling.
5. Screw oil fill plug back into oil fill hole. Tighten securely.
6. Wipe away any spilled oil.

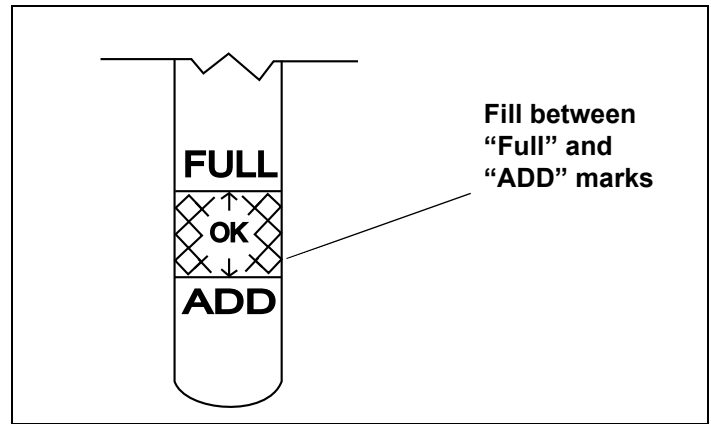

Figure 10. Engine Oil Level

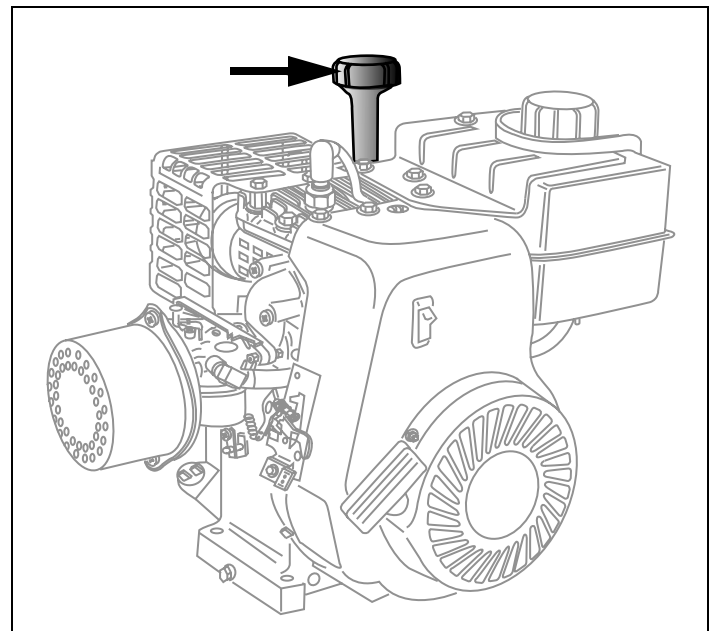

Figure 11. Possible Oil Fill Dipstick Location

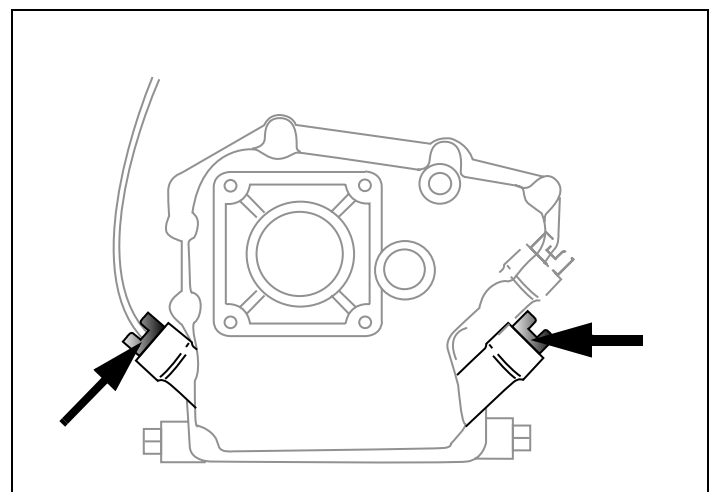

Figure 12. Possible Oil Fill Plug Location(s)

C. Engine Stop Switch

Power Sport Engines are equipped with an Engine Stop Switch. This rocker switch is used to shut off the ignition that supplies the spark plug with power. Pressing the switch to the “OFF” position will turn the engine off when it is running. This switch must be in the “ON” position or the engine will not start. See Figure 13.

D. Filling Fuel Tank

WARNING An adult should fuel this engine. NEVER allow children to refuel this engine. Gasoline (fuel) vapors are highly flammable and can explode. Fuel vapors can spread and be ignited by a spark or flame many feet away from engine. To prevent injury or death from fuel fires, follow these instructions:

1. Stop engine and allow it to cool before refueling.
2. Be sure engine is outdoors and in a well-ventilated area.
3. Clean area around fuel fill cap and remove anti-splash fuel fill cap. See Figure 14.

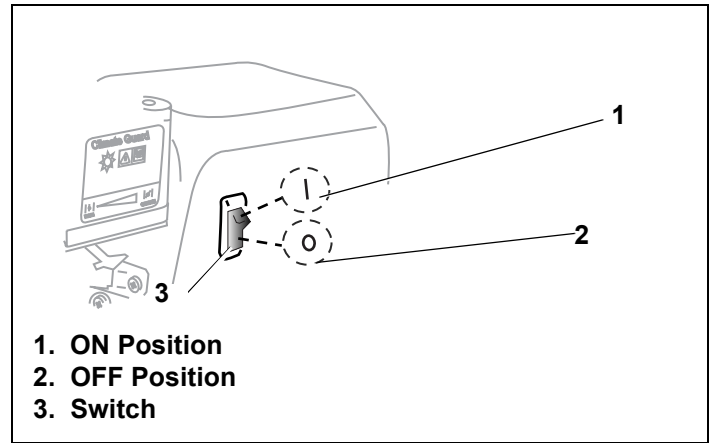

Figure 13. Engine Stop Switch

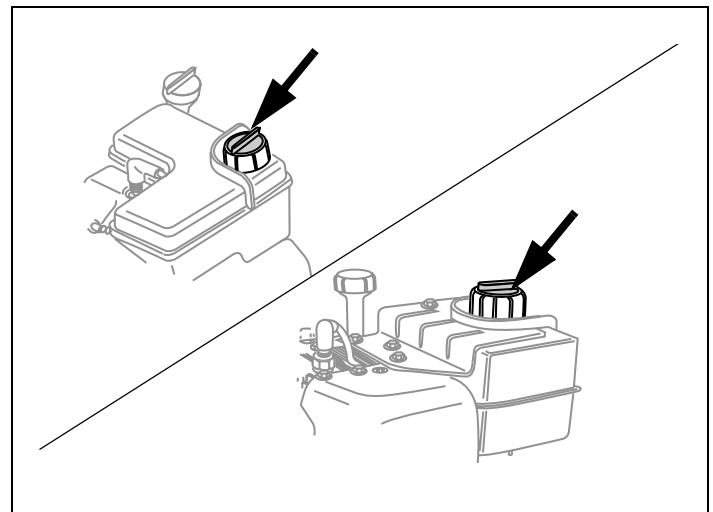

Figure 14. Possible Fuel Fill Cap Location(s)

4. Using an approved red GASOLINE container, add fuel slowly, being careful to avoid spilling. DO NOT overfill fuel tank. Leave space in the tank to allow fuel to expand without overflowing. See "B. Fuel" instructions on page 5.
5. Replace anti-splash fuel fill cap securely and wipe up spilled fuel before starting engine. If fuel is spilled DO NOT start engine. Move machine away from area of spillage. Avoid creating any source of ignition until fuel vapors are gone.

NOTES

Remove and discard white plastic fuel tank insert, if provided. See Figure 15.

Replace a damaged or missing gas cap only with a genuine Tecumseh replacement anti-splash fuel fill cap. Failure to do so may VOID YOUR WARRANTY. See Figure 16.

E. Optional Fuel Valve

Some engines are equipped with an optional fuel valve. See Figure 17.

1. Turn fuel valve counterclockwise to "OPEN" position.
2. Turn fuel valve clockwise to "OFF" position

NOTE

Always be sure fuel valve is in the "OFF" position after each use. See Figure 17.



Figure 15. Fuel Cap Insert Disposal Symbol

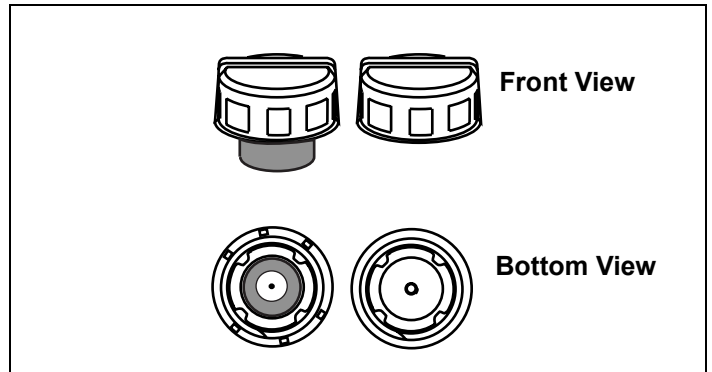

Figure 16. Possible Anti-Splash Fuel Fill Cap(s)

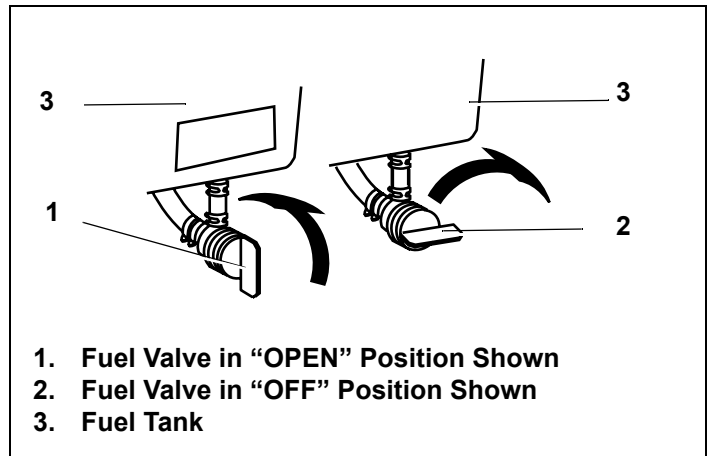

Figure 17. Optional Fuel Valve

V. Starting Your Engine

WARNING An adult should start the engine. Only allow children to start engine if an adult has determined they are experienced and capable of such operation.

NOTE

See "A. Engine Pre-Ride Checklist" instructions on page 6.

WARNING If you are unable to start this engine after following instructions in this manual, contact your Authorized Tecumseh Servicing Dealer. To avoid serious burn injuries or damage to your engine, DO NOT attempt to start or troubleshoot this engine in any other way. For example:

- DO NOT use starting fluid.
- DO NOT spray flammable vapors into carburetor or onto air cleaner.
- DO NOT put flammable liquids into carburetor or onto air cleaner.
- DO NOT operate engine or pull on starter rope with spark plug removed. Fuel can spray from spark plug hole and ignite.
- DO NOT apply throttle or gas pedal while starting.

This section contains starting instructions for several different types of engines. In order to locate the instructions that apply to your engine, first determine what type of starter you have. If you have an electric starter see "A. Engines with Electric Starters" instructions on page 12. If you have a manual recoil starter see "B. Engines with Recoil Starters" instructions.

Item Descriptions

The item descriptions listed below are for all Power Sport Engine models available and refer to Figures 18 thru 20. Take a moment to become familiar with your engine model.

1. Oil Fill Plug
2. Carburetor
3. Air Cleaner
4. Muffler
5. Muffler Guard
6. Oil Fill Dipstick
7. Spark Plug Cap
8. Fuel Fill Cap
9. On/Off Switch
10. Recoil Starter/Flywheel Guard
11. Starter Cord Handle
12. Levers/Linkage
13. Fuel Shut-Off Valve (If provided)
14. Primer

Only one of the following illustrations will apply to your engine. See Table 4.

Table 4. Model Assemblies

If your engine model is a:	Location:
LH318EA (HM80-90) LH358EA (HM100)	See Figure 18.
OH195EA/OH195EP	See Figure 19.
OH318EA	See Figure 20.

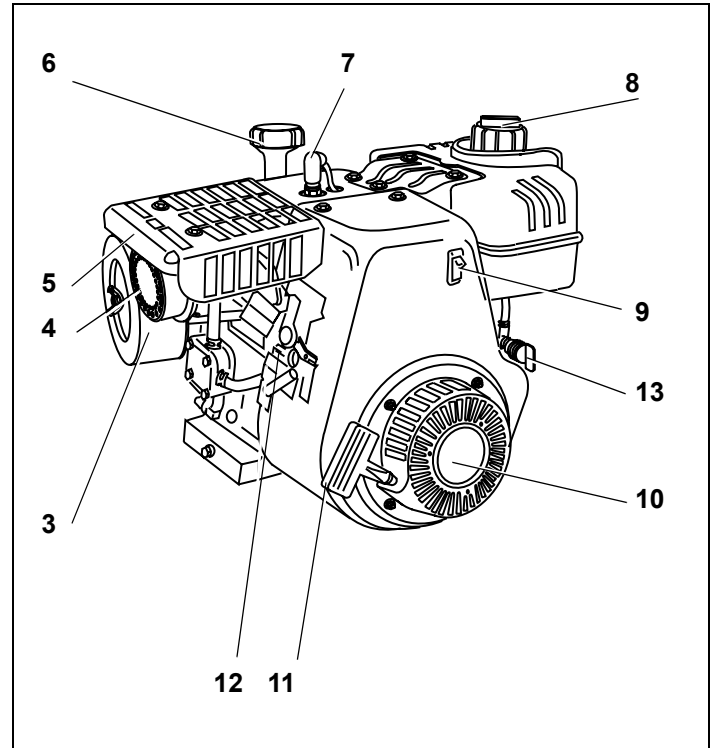

Figure 18. LH318EA (HM80-90), LH358EA (HM100) Model

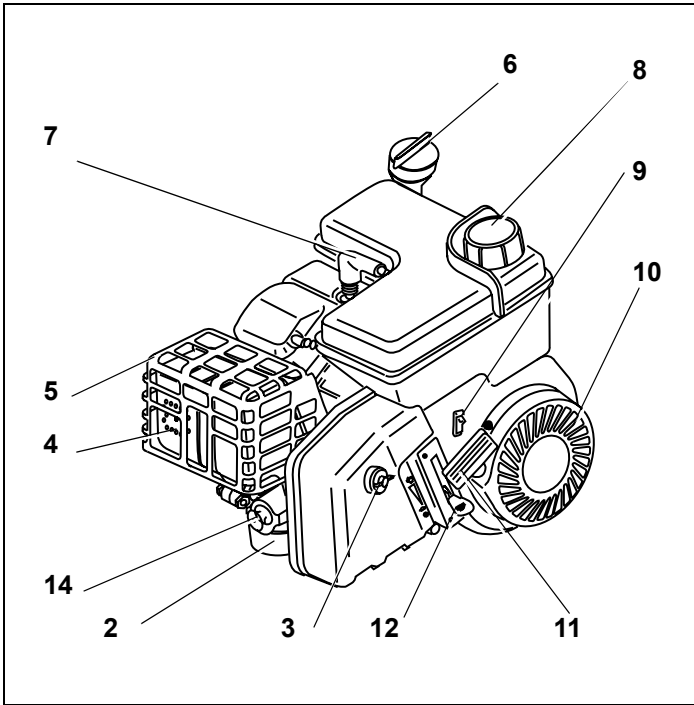

Figure 19. OH195EA/OH195EP Model

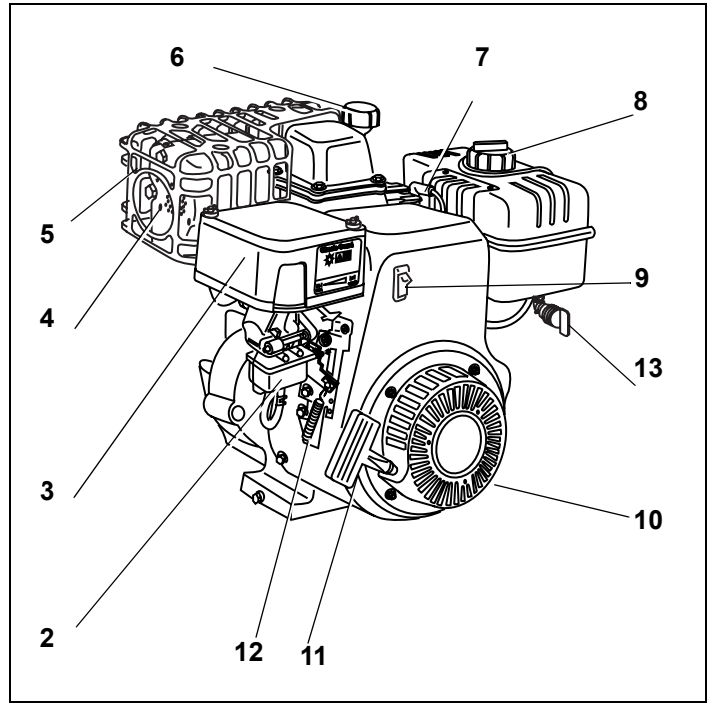

Figure 20. OH318EA

A. Engines with Electric Starters

Only one of the following two sections will apply to your engine. See Table 5.

Table 5. Engines with Electric Starters

If your engine has:	Go to:
Primer Bulb Only	"I. Engine With Primer Bulb" instructions.
Choke Only	"II. Engine with Choke" instructions on page 13.

I. Engine With Primer Bulb

1. To avoid carbon monoxide poisoning, be sure engine is outdoors in a well-ventilated area. See Figure 20.
2. Be sure fuel valve is open, if provided. See Figure 21.
3. When starting a cold engine, push primer bulb firmly with your thumb 3 times, allowing primer bulb to return completely to original position between pushes. See Figure 22.

NOTES

LH318EA (HM80-90), LH358EA (HM100) and OH318EA Models DO NOT have a primer bulb.

Cooler temperatures may require pushing primer bulb firmly with your thumb 5 times.

DO NOT use primer to restart a warm engine after a short shutdown. Doing so will flood the engine and may result in equipment malfunction.

4. Push starter button or turn ignition switch key to start engine.

NOTE

DO NOT operate an electric starter for more than 5 seconds each attempt.

5. When engine starts, release starter button or ignition switch key.
6. If engine fails to start after 3 attempts, repeat steps 2 thru 4.
7. If engine does not start after following steps 1 thru 6, contact your Authorized Tecumseh Servicing Dealer. DO NOT attempt to start or troubleshoot this engine in any other way.

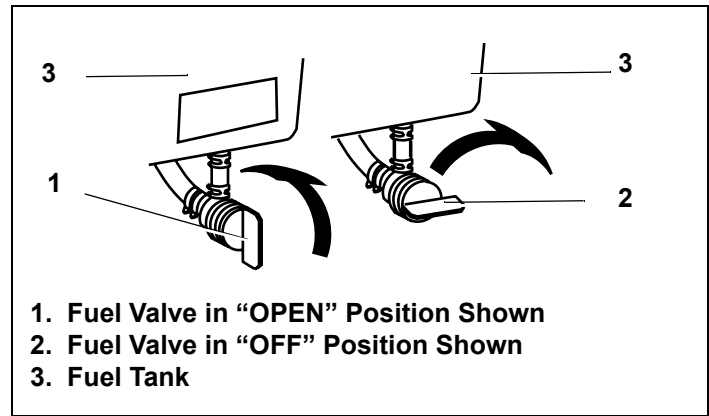

Figure 21. Optional Fuel Valve

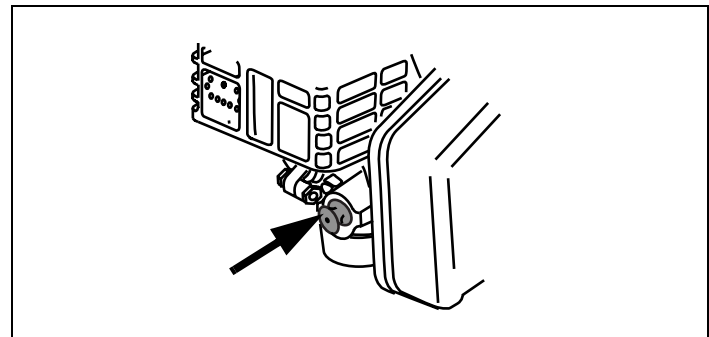

Figure 22. OH195EA/OH195EP Engine Primer Bulb

II. Engine with Choke

1. To avoid carbon monoxide poisoning, be sure engine is outdoors in a well-ventilated area.
2. Be sure fuel valve is open, if provided. See Figure 21.
3. Move Choke Control to "FULL CHOKE" position.

NOTES

Some engines are equipped with a horizontal mounted choke control. See Figure 23.

Some engines are equipped with a Remote Choke Control. See Figure 24.

Some OH195EA/OH195EP engines are equipped with a choke control lever under the muffler. See Figure 25.

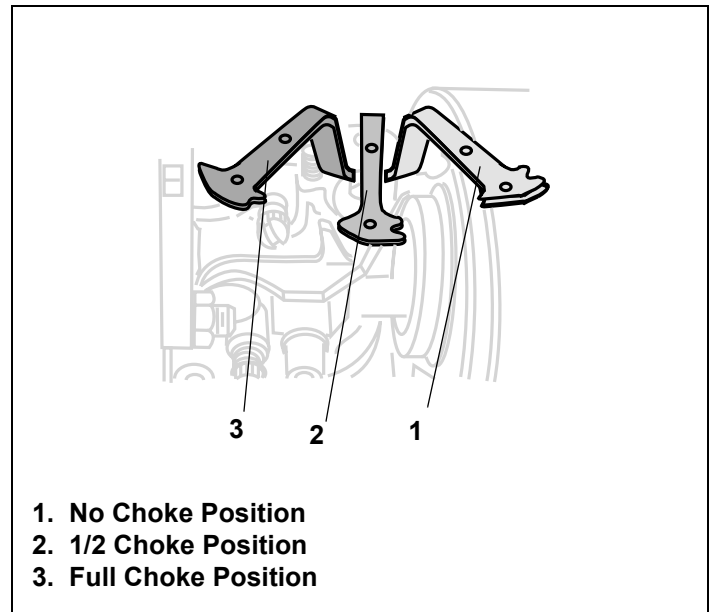

Figure 23. Horizontal Mount Choke Control Positions

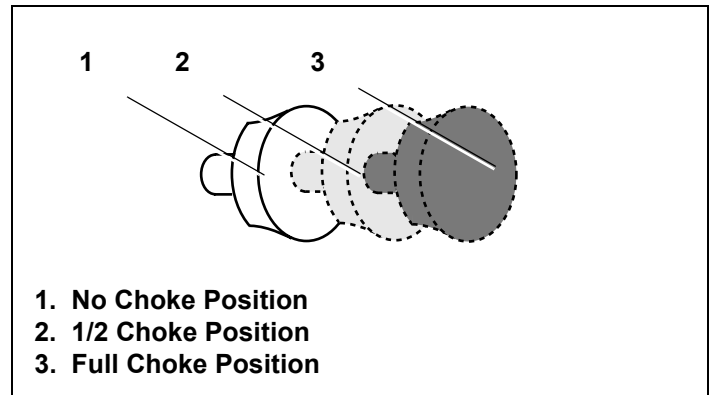

Figure 24. Remote Choke Control Positions

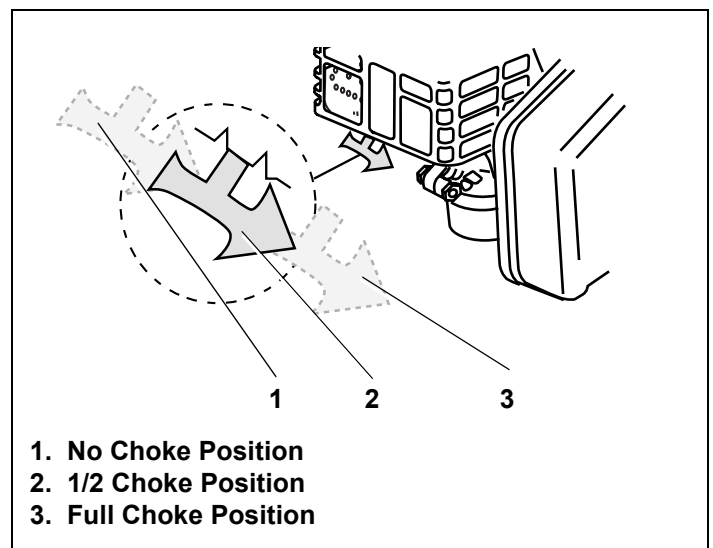

Figure 25. OH195EA/OH195EP Choke Control Positions

NOTES

OH318EA engines are equipped with a choke control lever located under the air cleaner. See Figure 26.

If restarting a warm engine move Choke Control to "NO CHOKE" position. See Figure 26.

Power Sport engines are equipped with a standard Spring Loaded Throttle Control to ensure the throttle will return to engine idle speed when it is released or if the cable fails. The throttle control must be in the idle position when starting engine. See Figure 27.

4. Push starter button or turn ignition switch key to start engine.

NOTE

DO NOT operate an electric starter for more than 5 seconds each attempt.

5. When engine starts:
 - a. Release starter button or ignition switch key.
 - b. Momentarily move Choke Lever to "1/2 CHOKE" position until engine runs smoothly.
 - c. Next, move Choke Lever to "NO CHOKE" position.

NOTES

If engine starts but falters when Choke Lever is moved to "NO CHOKE" position:

- a. Momentarily move Choke Lever back to "FULL CHOKE" position.
 - b. Next, move Choke Lever to "1/2 CHOKE" position until engine runs smoothly.
 - c. Finally, move Choke Lever to "NO CHOKE" position.
6. If engine dies after Choke Lever is moved to "NO CHOKE" position, repeat steps 2 thru 5 to restart engine.
 7. If engine fires, but does not continue to run, move Choke Lever to "NO CHOKE" position and start engine.
 8. If engine fails after 3 attempts in the "NO CHOKE" position, repeat steps 2 thru 7 to restart engine.
 9. If engine does not start after following steps 1 thru 8, contact your Authorized Tecumseh Servicing Dealer. DO NOT attempt to start or troubleshoot this engine in any other way.

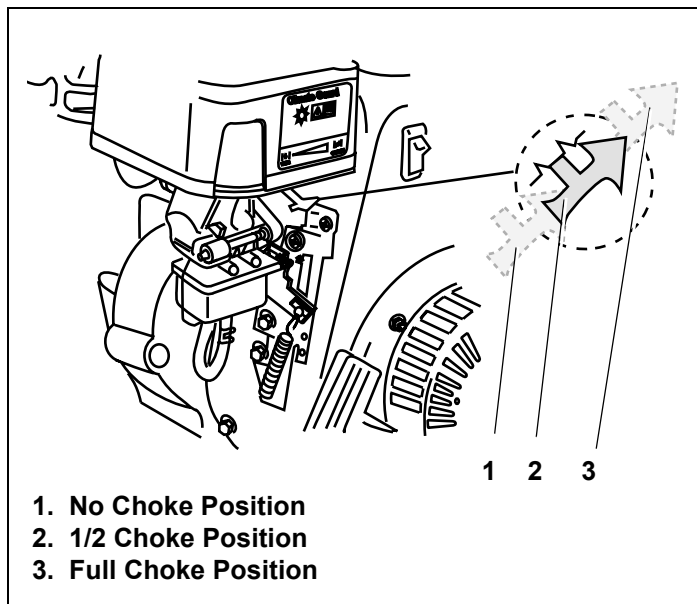

Figure 26. OH318EA Choke Control Positions

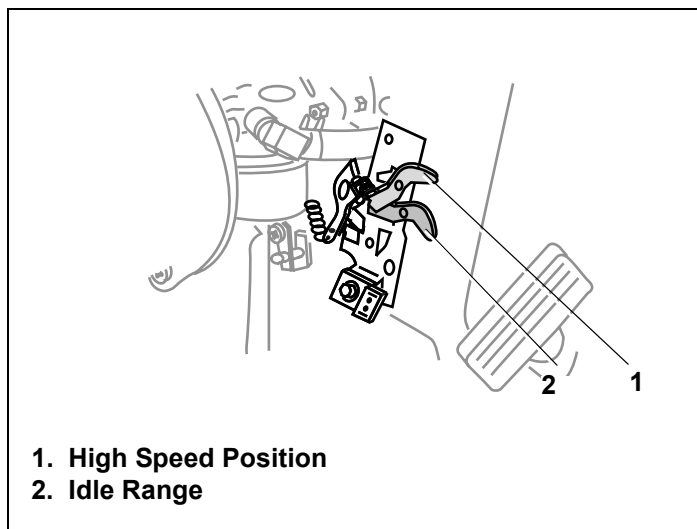

Figure 27. Engine Speed Control Positions

B. Engines with Recoil Starters

I. Engine With Primer Bulb

Only one of the following two sections will apply to your engine. See Table 6.

Table 6. Engines with Recoil Starters

If your engine has:	Go to:
Primer Bulb Only	"I. Engine With Primer Bulb" instructions.
Choke Only	"II. Engine With Choke" instructions on page 16.

1. To avoid carbon monoxide poisoning, be sure engine is outdoors in a well-ventilated area.
2. Be sure fuel valve is open, if provided. See Figure 28.
3. When starting a cold engine, push primer bulb firmly with your thumb 3 times, allowing primer bulb to return completely to original position between pushes. See Figure 29.

NOTES

LH318EA (HM80-90), LH358EA (HM100) and OH318EA Models DO NOT have a primer bulb.

Cooler temperatures may require pushing primer bulb firmly with your thumb 5 times.

DO NOT use primer to restart a warm engine after a short shutdown. Doing so will flood the engine and may result in equipment malfunction.

WARNING When pulling starter rope, the rope can unexpectedly jerk back toward engine causing serious injury. To avoid this risk, carefully follow these instructions:

4. Grasp starter cord handle. See Figure 30.
 - a. Pull rope out slowly until you feel drag.
 - b. Next, pull rope with one rapid full arm stroke.
 - c. Return rope slowly to original position.

NOTE

Following the instructions listed in the steps above avoids potential damage to the recoil mechanism.

5. If engine fails to start after 3 attempts, repeat steps 2 thru 4.
6. If engine does not start after following steps 1 thru 5, contact your Authorized Tecumseh Servicing Dealer. DO NOT attempt to start or troubleshoot this engine in any other way.

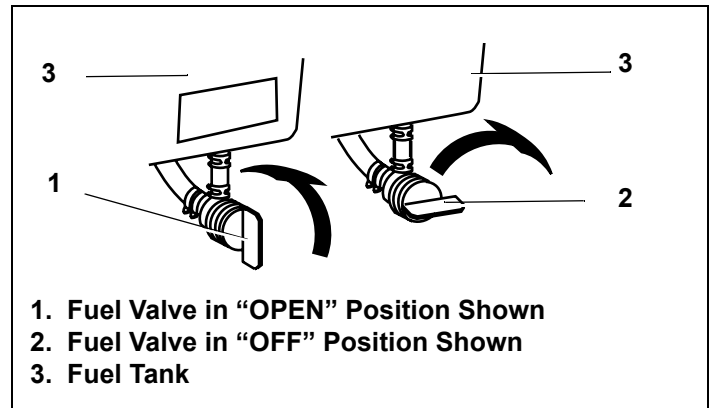

Figure 28. Optional Fuel Valve

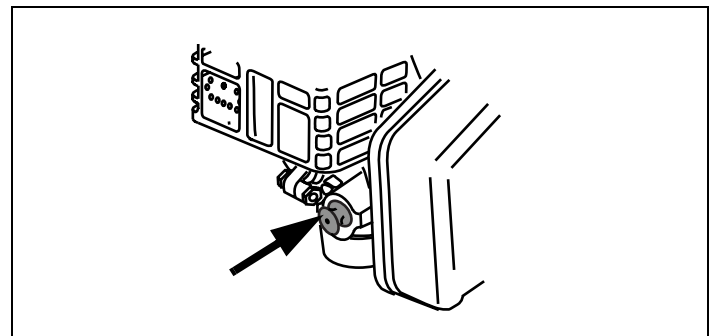

Figure 29. OH195EA/OH195EP Engine Primer Bulb

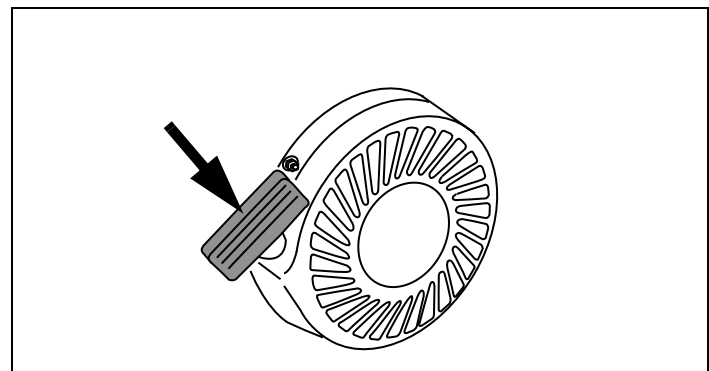

Figure 30. Starter Cord Handle

II. Engine With Choke

1. To avoid carbon monoxide poisoning, be sure engine is outdoors in a well-ventilated area.
2. Be sure fuel valve is open, if provided. See Figure 28 on page 15.
3. Move Choke Control to "FULL CHOKE" position.

NOTES

Some engines are equipped with a horizontal mounted choke control. See Figure 31.

Some engines are equipped with a Remote Choke Control. See Figure 32.

Some OH195EA/OH195EP engines are equipped with a choke control lever located under the muffler. See Figure 33.

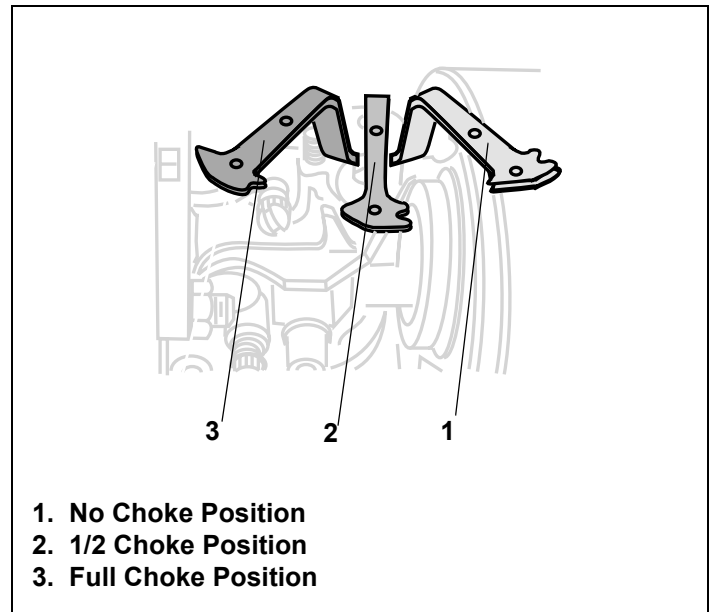

Figure 31. Horizontal Mount Choke Control Positions

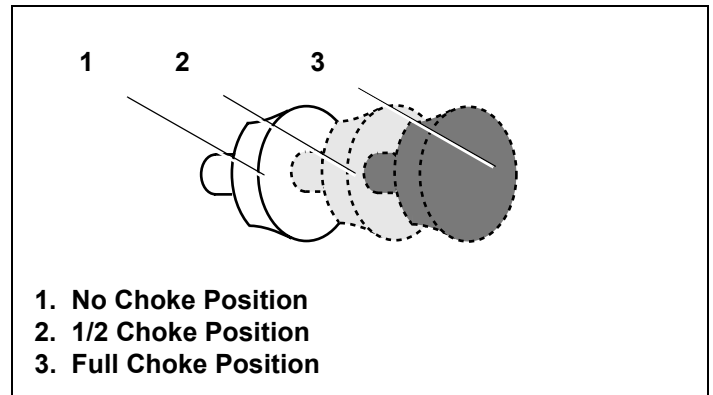

Figure 32. Remote Choke Control Positions

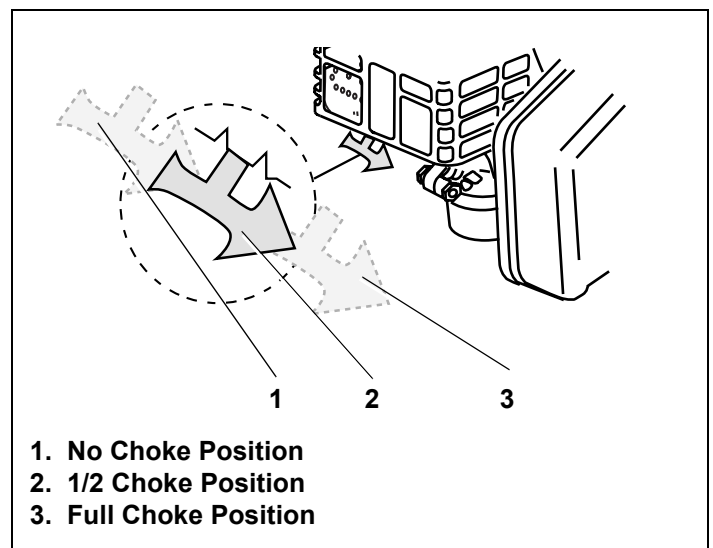

Figure 33. OH195EA/OH195EP Choke Control Positions

NOTES

OH318EA engines are equipped with a choke control lever located under the air cleaner. See Figure 34.

If restarting a warm engine move Choke Control to "NO CHOKE" position. See Figure 31 thru 34.

Power Sport engines are equipped with a standard Spring Loaded Throttle Control to ensure the throttle will return to engine idle speed when it is released or if the cable fails. The throttle control must be in the idle position when starting engine. See Figure 35.

WARNING

When pulling starter rope, the rope can unexpectedly jerk back toward engine causing serious injury. To avoid this risk, carefully follow these instructions:

4. Grasp starter cord handle. See Figure 30 on page 15.
 - a. Pull rope out slowly until you feel drag.
 - b. Next, pull rope with one rapid full arm stroke.
 - c. Return rope slowly to original position.

NOTE

Following the instructions in the steps above will also help avoid potential damage to the recoil mechanism.

5. When engine starts:
 - a. Momentarily move Choke Lever to "1/2 CHOKE" position until engine runs smoothly.
 - b. Next, move Choke Lever to "NO CHOKE" position.

NOTES

If engine starts but falters when Choke Lever is moved to "NO CHOKE" position:

- a. Momentarily move Choke Lever back to "FULL CHOKE" position.
 - b. Next, move Choke Lever to "1/2 CHOKE" position until engine runs smoothly.
 - c. Finally, move Choke Lever to "NO CHOKE" position.
6. If engine dies after Choke Lever is moved to "NO CHOKE" position, repeat steps 2 thru 5 to restart engine.
 7. If engine fires, but does not continue to run, move Choke Lever to "NO CHOKE" position and start engine.
 8. If engine fails after 3 attempts in the "NO CHOKE" position, repeat steps 2 thru 7 to restart engine.
 9. If engine does not start after following steps 1 thru 8, contact your Authorized Tecumseh Servicing Dealer. DO NOT attempt to start or troubleshoot this engine in any other way.

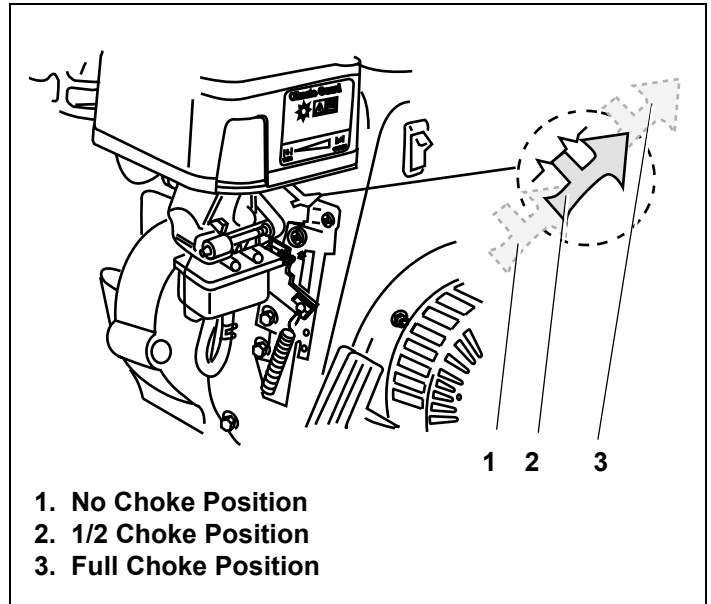

Figure 34. OH318EA Choke Control Positions

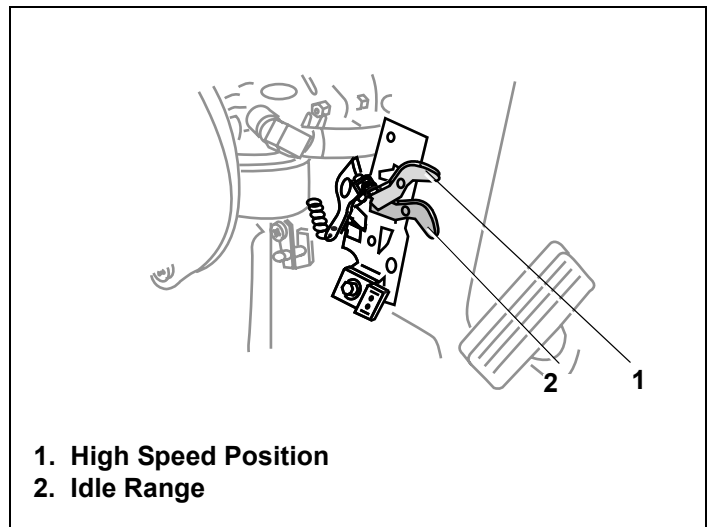

Figure 35. Engine Speed Control Positions

VI. Stopping Your Engine and Short-Term Storage

Stop engine according to equipment manufacturer's instructions.

WARNING To avoid unsupervised operation of a recreational vehicle, especially by children, NEVER leave the engine unattended when it is running. Always turn off the engine before exiting the vehicle and remove ignition key, if provided.

WARNING NEVER store the engine with fuel in the fuel tank inside a building with potential sources of ignition such as hot water and space heaters, clothes dryers, electric motors, etc.

VII. Transporting Your Recreational Vehicle

WARNING NEVER transport this vehicle inside another vehicle or in any enclosed space if there is any gasoline in the tank. Fuel vapor or spilled fuel may ignite.

If there is fuel in the fuel tank, close the fuel shut off valve, if equipped, and transport the recreational vehicle in an open vehicle, such as an open trailer or open bed of a pickup truck.

If you do not have an open vehicle and have to transport the recreational vehicle in a closed vehicle, follow these steps for emptying the fuel tank before transporting:

1. Empty fuel tank by using a commercially available suction device designed for use with gasoline.

WARNING DO NOT pour fuel from engine or siphon fuel by mouth.

2. Drain fuel into an approved red GASOLINE container, being careful to avoid spilling.
3. Run the engine until remaining fuel is consumed.

WARNING NEVER leave the engine unattended when it is running and NEVER run engine in enclosed areas.

VIII. Maintenance

WARNING An adult should perform maintenance on this engine. Only allow children to perform maintenance if an adult has determined they are experienced and capable of such operation.

WARNING To prevent accidental starting when working on equipment, always:

- Disconnect spark plug wire and keep it away from spark plug. See Figure 36.
- Keep the disconnected spark plug wire securely away from metal parts where arcing could occur.
- Attach the spark plug wire to the grounding post, if provided. See Figure 37.
- Disconnect battery at negative terminal first, if engine is equipped with an electric starter.
- Turn off all engine switches.
- Remove ignition key, if provided.

WARNING The muffler and other engine parts become extremely hot during operation and remain hot after the engine has stopped. To avoid severe burns on contact, stay away from these areas.

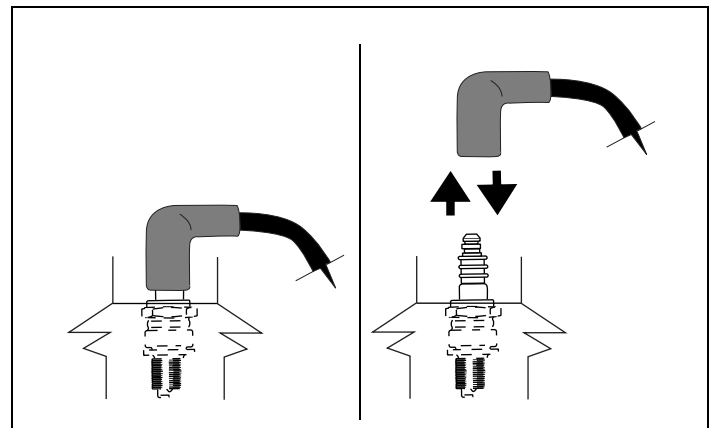

Figure 36. Disconnecting/Connecting Spark Plug

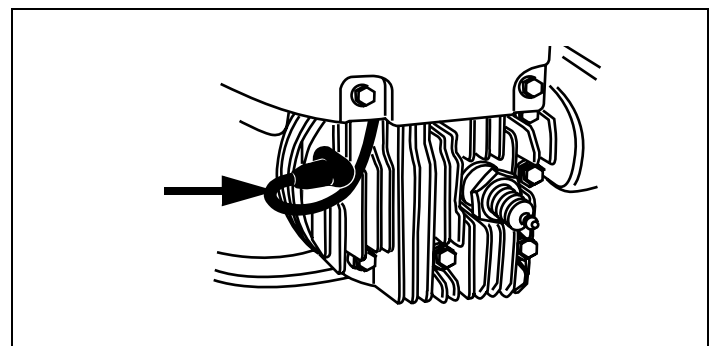

Figure 37. Spark Plug Grounding Post

A. Checking and Changing Oil

To avoid engine damage, it is important to:

- Check oil level before each use and every 5 operating hours when engine is warm.
 - Change oil after first 2 operating hours and every 3 months or every 25 operating hours thereafter; more often if operated in extremely dusty or dirty conditions. Engine should still be warm but not hot from recent use.
1. Be sure you find the correct drain plug location, if provided. See Figure 38.
 2. Disconnect spark plug wire and keep it away from spark plug. See "G. Avoid Accidental Starts" instructions on page 3. See Figure 36.
 - Keep the disconnected spark plug wire securely away from metal parts where arcing could occur.
 - Attach the spark plug wire to the grounding post, if provided. See Figure 37.
 3. Be sure the gas cap is on and is tightened securely.
 4. Clean area around oil drain plug.
 5. Place approved recyclable oil container under oil drain plug, tipping engine to position the oil drain plug at the lowest point on the engine.
 6. Remove oil drain plug and drain oil. See Figure 38.
- NOTE**
Used oil must be disposed of at a proper collection center.
7. Install oil drain plug and tighten securely.
 8. Fill with recommended oil. See "III. Oil and Fuel Specifications" instructions on page 5. See Table 1 and see Table 2 on page 5. See Figure 39.
 9. Wipe away any spilled oil.
 10. Carefully disconnect spark plug wire from grounding post, if provided. See Figure 37.
 11. Carefully re-connect spark plug wire to spark plug. See Figure 36.

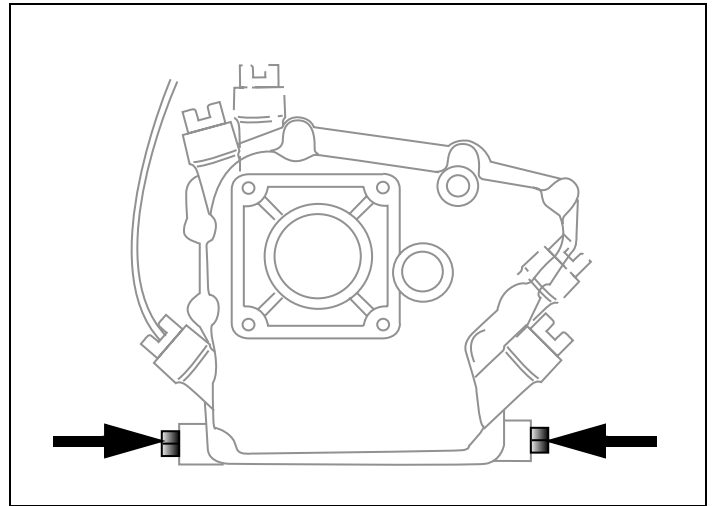

Figure 38. Possible Oil Drain Plug Location(s)

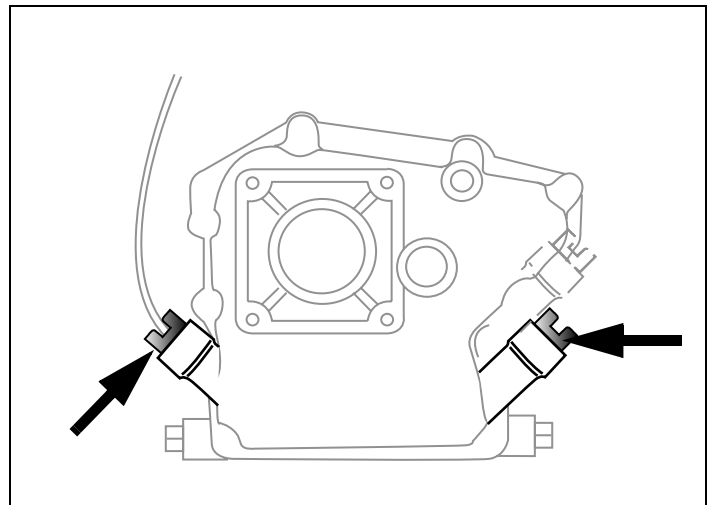

Figure 39. Possible Oil Fill Plug Location(s)

B. Removing Debris From Engine

Before each use, remove grass clippings, dirt, debris, snow or ice from the following areas:

- Cooling fins
- Air intake screens
- Levers
- Linkage
- Guards

Removing debris will facilitate adequate cooling, correct engine speed or reduce the risk of fire. See Figure 40.

C. Spark Plug

Check spark plug yearly or every 100 operating hours.

1. Clean area around spark plug.
2. Remove and inspect spark plug.
3. Replace spark plug if porcelain is cracked or if electrodes are:
 - Pitted
 - Burned
 - Fouled with deposits
4. Check electrode gap with wire feeler gauge and set gap to .030 in. (0.76mm) if necessary. See Figure 41.
5. Install spark plug and tighten securely.

NOTE

A resistor spark plug must be used for replacement. Contact your Authorized Tecumseh Servicing Dealer for a Tecumseh Resistor Spark Plug.

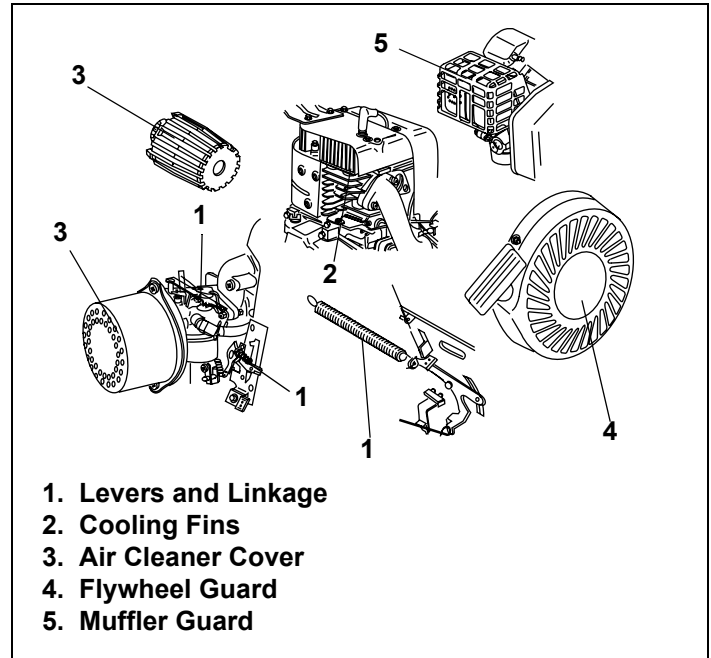

Figure 40. Debris Removal Areas

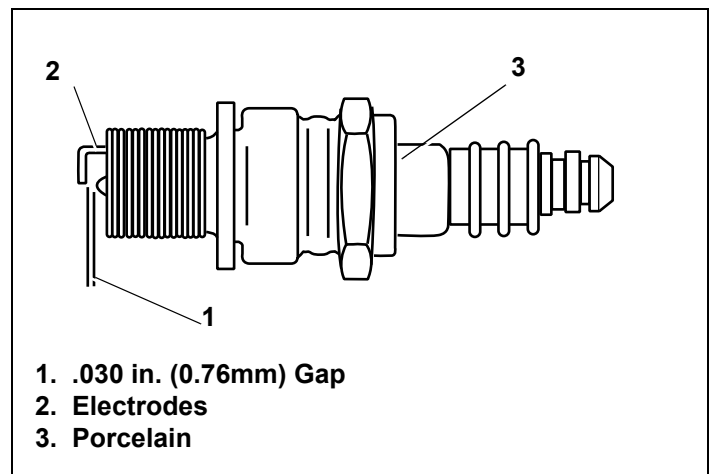

Figure 41. Resistor Spark Plug

D. Cleaning/Replacing Air Cleaner

Your engine has an air cleaner which helps prevent premature engine wear and failure. NEVER run engine without complete air cleaner installed on engine. Your air cleaner's filter(s) periodically needs to be cleaned or replaced. To do this, you first need to determine the type of air cleaner on your engine. Your engine will be equipped with one of the following air cleaners; Type A, B, C, D or E. See Figure 42 thru Figure 46. Follow instructions for the air cleaner type that resembles your model.

NOTE

Contact your Authorized Tecumseh Servicing Dealer for Tecumseh Air Cleaners.

I. Servicing Foam Pre-Filters

Clean foam pre-filter every 3 months or every 25 operating hours. Clean daily if used in extremely dusty conditions. After removing the pre-filter, follow these cleaning instructions below:

1. Wash in warm water and detergent solution then press (DO NOT twist) until all dirt is removed.
2. Rinse thoroughly until water is clear.
3. Wrap in a clean cloth and press (DO NOT twist) until completely dry.

NOTE

DO NOT oil a foam pre-filter.

4. Replace foam pre-filter onto paper filter.

II. Servicing Paper Filters

Paper filters cannot be cleaned and must be replaced once a year or every 100 operating hours; more often if used in extremely dusty conditions. Replacement filters are available at an Authorized Tecumseh Servicing Dealer. Follow the instructions next to the drawing of your air cleaner to remove and replace it.

NOTE

DO NOT put oil on or clean a paper filter.

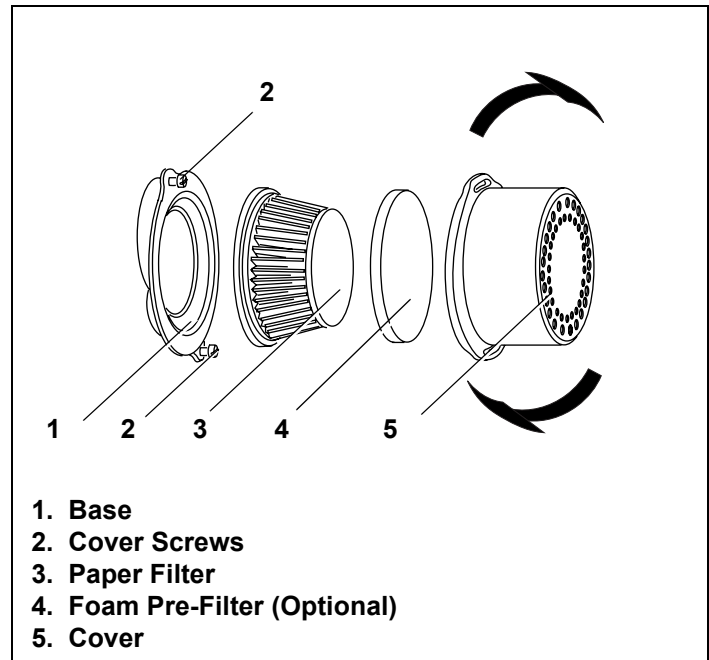

Figure 42. Type "A" Air Cleaner Assembly

E. Type "A" Air Cleaner

1. Loosen cover screws. See Figure 42.
2. Turn cover counterclockwise and remove from base.
3. Remove optional foam pre-filter, if provided, from cover. Inspect for dirt or debris accumulation. If either is present see "I. Servicing Foam Pre-Filters" instructions.
4. Remove paper filter from base. Inspect filters for discoloration or dirt accumulation. If either is present, see "II. Servicing Paper Filters" instructions.
5. Clean inside of base and cover thoroughly.
6. Install new paper element into base.
7. Install optional foam pre-filter into cover.
8. Turn cover clockwise and attach to base.
9. Tighten screws securely.

F. Type "B" Air Cleaner

1. Turn cover to left (counterclockwise) and remove it and paper filter from base. See Figure 43.
2. Discard filter.
3. Clean cover and base thoroughly.
4. Install new paper filter into cover.
5. Position clean cover and filter against base with tab on cover inserted into lower left corner of slot in base.
6. Push cover firmly against base and turn to right (clockwise) as far as it will go.
7. Be sure retainers are locked around base.

G. Type "C" Air Cleaner

1. Remove wing nut. See Figure 44.
2. Remove cover and clean thoroughly.
3. Remove foam pre-filter, if provided, from outside of paper filter. Inspect for dirt or debris accumulation. If either is present see "I. Servicing Foam Pre-Filters" instructions on page 21.
4. Remove paper filter element from base. Inspect filters for discoloration or dirt accumulation. If either is present, see "II. Servicing Paper Filters" instructions on page 21.
5. Clean inside of base and cover thoroughly.
6. Install clean paper filter element onto base.
7. Install clean foam pre-filter, if provided, over paper element.
8. Install clean cover over filters.
9. Install wing nut and tighten securely.

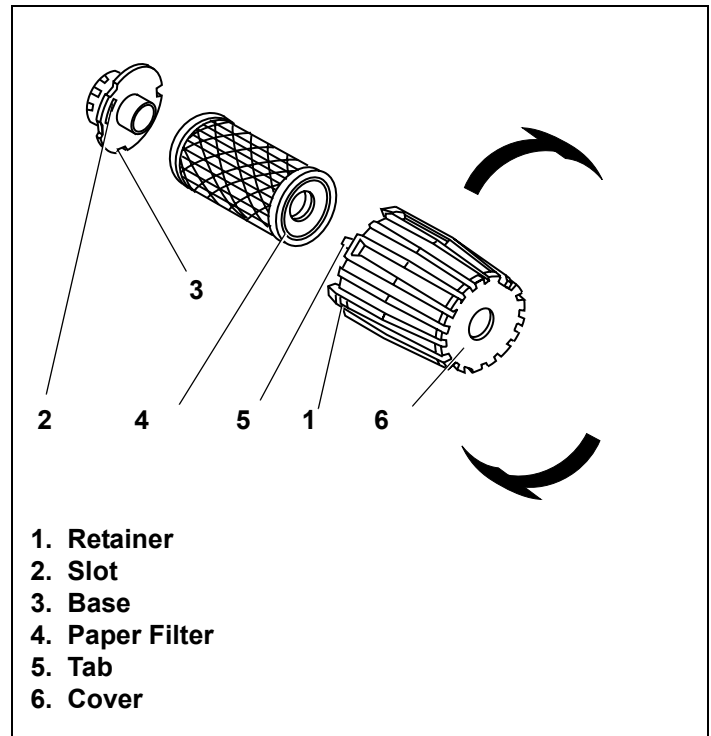

Figure 43. Type "B" Air Cleaner Assembly

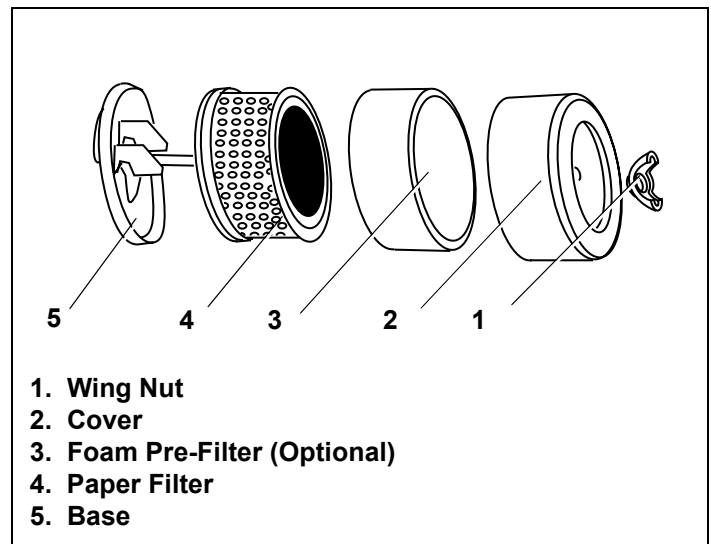

Figure 44. Type "C" Air Cleaner Assembly

H. Climate Guard® Anti-Icing Air Cleaners

Some engines may be equipped with a Climate Guard anti-icing air cleaner that prevents ice from forming in the carburetor when the engine is run at temperatures below 32 ° F (0 ° C).

Engines equipped with the baffle will have an opening which draws warm air from the muffler into the air cleaner housing. To work effectively, it is necessary for the Cold Weather Baffle to block cold air from entering the air cleaner.

I. Type “D” Air Cleaner

1. Remove wing nut and cover. See Figure 45.
2. Remove foam pre-filter, if provided, from cover. Inspect for dirt or debris accumulation. If either is present see "I. Servicing Foam Pre-Filters" instructions on page 21.
3. Remove paper element from base. Inspect for dirt or debris accumulation. If either is present see "II. Servicing Paper Filters" instructions on page 21.
4. Clean inside of base and cover thoroughly.
5. Install clean paper element into base.
6. Install clean foam pre-filter, if provided, into cover.
7. Install cover on base.
8. Install wing nut and tighten securely.

A. At temperatures of 32 ° F (0 ° C) and Below

1. Remove wing nut from air cleaner cover. See Figure 45.
2. Remove air cleaner cover from base.
3. Remove red baffle from inside of air cleaner cover.
4. Insert red baffle in “WINTER” position shown.
5. Install air cleaner cover onto base.
6. Install wing nut and tighten securely.

B. At temperatures above 32 ° F (0 ° C)

1. Remove wing nut from air cleaner cover. See Figure 45.
2. Remove air cleaner cover from base.
3. Remove red baffle from inside of air cleaner cover.
4. Insert red baffle in “SUMMER” position shown.
5. Install air cleaner cover onto base.
6. Install wing nut and tighten securely.

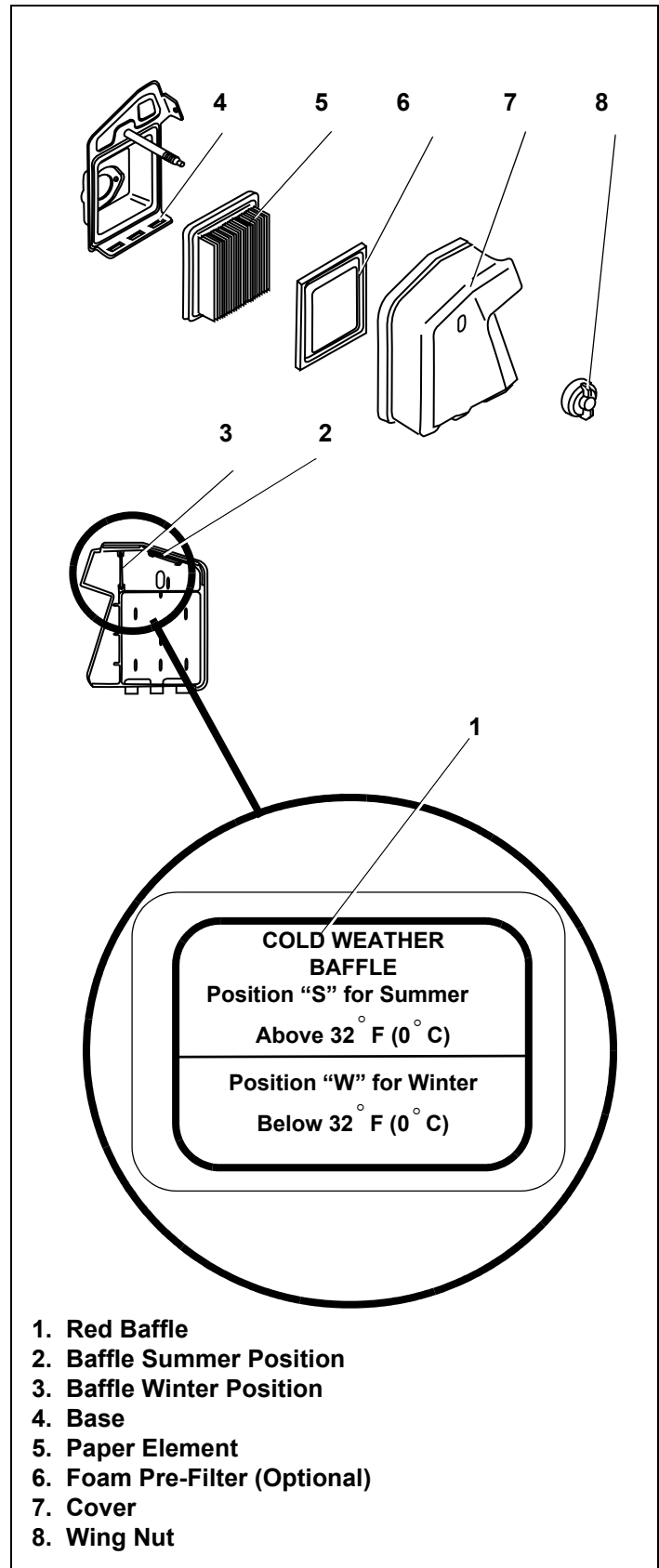

Figure 45. Type “D” Climate Guard Air Cleaner Assembly

II. Type “E” Air Cleaner

1. Remove wing nuts and air cleaner cover.
2. Remove foam pre-filter from paper filter, if provided, and inspect for dirt or debris accumulation. If either is present see "I. Servicing Foam Pre-Filters" instructions on page 21.
3. Remove paper filter from base and inspect for dirt or debris accumulation. If either is present see "II. Servicing Paper Filters" instructions on page 21.
4. Clean inside of base and air cleaner cover thoroughly.
5. Install paper filter into base.
6. Install foam filter onto paper filter.
7. Install air cleaner cover on base.
8. Install wing nuts and tighten securely.

A. At temperatures of 32 ° F (0 ° C) and Below

1. Remove wing nuts from air cleaner cover. See Figure 46.
2. Remove air cleaner cover from base.
3. Rotate air cleaner cover in “WINTER” position shown. See Figure 47.
4. Install air cleaner cover onto base.

NOTE

Be sure air cleaner cover is in correct “WINTER” position with snowflake symbol visible.

5. Install wing nuts and tighten securely.

B. At temperatures above 32 ° F (0 ° C)

1. Remove wing nuts from air cleaner cover. See Figure 46.
2. Remove air cleaner cover from base.
3. Rotate air cleaner cover in “SUMMER” position shown. See Figure 47.
4. Install air cleaner cover onto base.

NOTE

Be sure air cleaner cover is in correct “SUMMER” position with sun symbol visible.

5. Install wing nuts and tighten securely.

I. Alternator (Optional)

For alternator related electrical problems such as:

- Inoperative starter
- Discharged battery
- Fuse replacement
- Alternator maintenance/repairs

See your equipment manufacturer’s instructions and an Authorized Tecumseh Servicing Dealer.

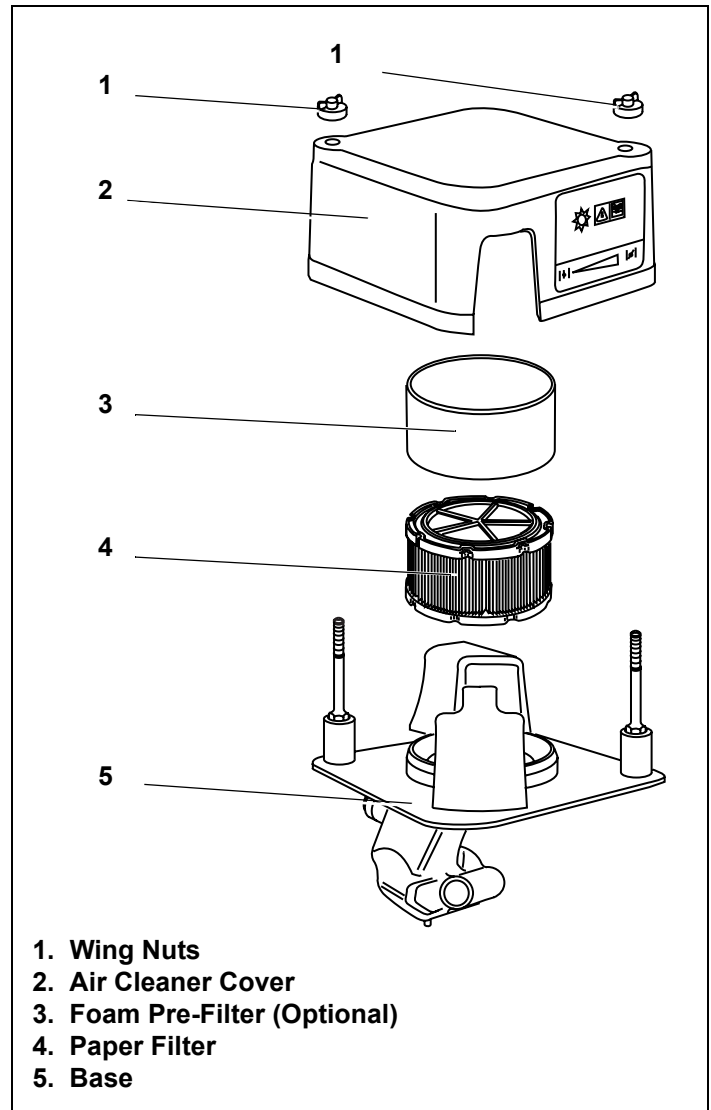

Figure 46. Type “E” Climate Guard Air Cleaner Assembly

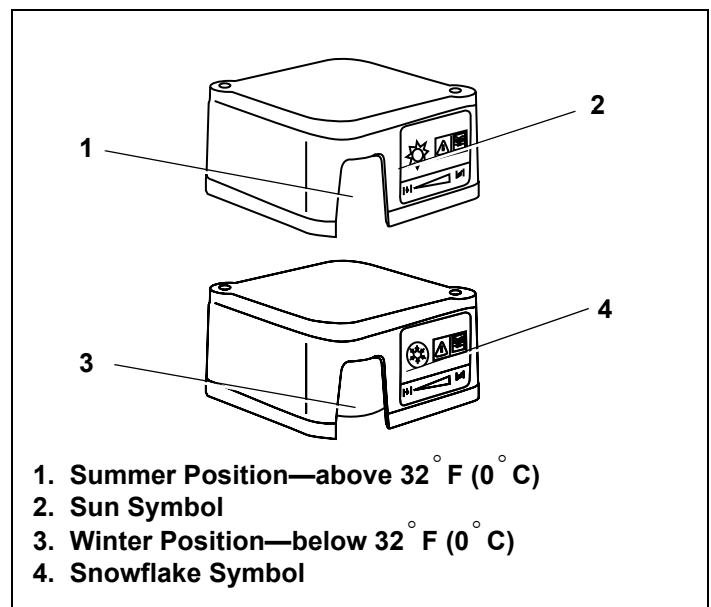

Figure 47. Air Cleaner Cover Positions

J. Adjustments

Do not make any engine adjustments. Factory settings are satisfactory for most conditions. If adjustments are needed, contact your Authorized Tecumseh Servicing Dealer.

K. Carburetor

If you think your carburetor needs adjusting, see your nearest Authorized Tecumseh Servicing Dealer. Engine performance should not be affected at altitudes up to 7,000 feet (2,134 meters). For operation at higher elevations, contact your Authorized Tecumseh Servicing Dealer.

L. Engine Speed



WARNING

To avoid serious injury or death, do not modify engine in any way.

Tampering with the governor setting can lead to a runaway vehicle and cause the engine to operate at unsafe speeds. NEVER tamper with factory setting of engine governor.

Running the engine faster than the speed set at the factory can be dangerous and will VOID THE ENGINE WARRANTY.

IX. Storing Your Engine

A. Short Term/Seasonal Storage

I. Clean Engine

Before servicing the engine remove the blower housing. In addition, remove grass clippings, dirt and debris from the following areas:

- Cooling fins
- Air intake screen
- Levers
- Linkage
- Guards
- Carburetor
- Head

Removing debris will facilitate adequate cooling, correct engine speed and reduce the risk of fire.

II. Fuel Storage



WARNING

NEVER store engine with fuel in fuel tank inside a building with potential sources of ignition such as hot water and space heaters, clothes dryers, electric motors, etc. Failure to do so may result in an explosion and result in death or serious injury.

NOTE

If engine fuel stored in the gas tank and/or an approved gas container is to be unused without gasoline stabilizer for more than 15-30 days, prepare it for short term/seasonal storage. See "IV. Fuel Treatment" instructions on page 26.

If engine fuel is to be stored for more than one season, without gasoline stabilizer, it will gradually deteriorate. Also, if it is stored in the engine's gas tank without gasoline stabilizer it is likely that your carburetor will have gum deposits, a clogged fuel system and will void your warranty. Prepare the fuel for extended storage. See "B. Extended Storage" instructions on page 26.

If you operate the engine during all 4 seasons, it is not necessary to lubricate the cylinder bore.

III. Fuel System

To avoid stale gas and carburetor problems, treat the fuel system in the following method below:

NOTE

Tecumseh recommends using **ULTRA-FRESH™** or Fuel Saver Plus Gasoline Stabilizer plus Fuel System Cleaner as an acceptable method of minimizing formation of fuel gum deposits during storage. This product is available from your Authorized Tecumseh Servicing Dealer.

Always follow mix ratio found on stabilizer container. Failure to do so may result in equipment damage.

It is not necessary to drain stabilized gas from carburetor.

IV. Fuel Treatment

1. Add fuel stabilizer according to manufacturer's instructions.
2. Run engine at least 10 minutes after adding stabilizer to allow it to reach carburetor.

 **WARNING** NEVER store the engine with fuel in the fuel tank inside a building with potential sources of ignition such as hot water and space heaters, clothes dryers, electric motors, etc.

NOTE

Instead of using a fuel preservative/stabilizer, you can empty the fuel tank as described under "I. Draining Fuel" instructions. See "B. Extended Storage" instructions.

B. Extended Storage

I. Draining Fuel

NOTES

Clean debris from engine before draining fuel from carburetor. See "I. Clean Engine" instructions on page 25.

If you have prepared your fuel for short term storage it is not necessary to drain fuel that contains stabilizer from your carburetor. See "A. Short Term/Seasonal Storage" instructions on page 25.

 **WARNING** To avoid severe injury or death, DO NOT pour fuel from engine or siphon fuel by mouth.

1. To prevent serious injury from fuel fires, empty fuel tank by running engine until it stops from lack of fuel. DO NOT attempt to pour fuel from engine.
2. Run the engine while waiting until the remaining fuel is consumed.

 **WARNING** NEVER leave the engine unattended when it is running and NEVER run engine in enclosed areas.

3. Begin servicing the cylinder bore. See "II. Oil Cylinder Bore" instructions on page 27.

II. Oil Cylinder Bore

 **WARNING** When lubricating cylinder bore, fuel may spray from spark plug hole. To prevent serious injury from fuel fires, follow these instructions:

1. Disconnect spark plug wire and keep it away from spark plug. See Figure 36.
 - Keep the disconnected spark plug wire securely away from metal parts where arcing could occur.
 - Attach the spark plug wire to the grounding post, if provided. See Figure 37.
- Disconnect battery at negative terminal first, if engine is equipped with an electric starter.
- Turn off all engine switches.
- Remove ignition key, if provided.
1. Remove spark plug.
2. Squirt 1oz. (30ml) of clean engine oil into spark plug hole.
3. Cover spark plug hole with rag to prevent fuel from spraying from spark plug hole when starter rope is pulled.

NOTES

For engines equipped with recoil starters proceed to Step 5.

For engines equipped with electric starters proceed to Step 6.

4. Grasp starter cord handle and pull out slowly using a full arm stroke. Repeat once. (This will distribute oil throughout the cylinder to prevent corrosion during storage.)
5. Install spark plug.
6. Carefully disconnect spark plug wire from grounding post, if provided.
7. Connect spark plug wire before attempting to start engine.

III. Battery

See equipment manufacturer's instructions for proper battery storage, if provided.

IV. Clean Engine

Remove any grass clippings, dirt, debris, snow, ice or slush from exterior of engine.

X. Preventing Forest, Brush and Grass Fires

Local, state and federal laws may require use of a spark arrester to prevent fires. For example, it is a violation of California Public Resources Code (section 4442) to use or operate engine on any forest-covered, brush-covered or unimproved grass-covered land unless engine is equipped with a spark arrester. Spark arrester must be maintained in effective working order by owner and/or operator.

To determine if your engine has a spark arrester, locate the muffler on your engine. For example, the muffler discharge will have a spark arrester cover that reads "Tecumseh Screen Type 36085".

If your engine does not have a spark arrester, you may purchase one from your Authorized Tecumseh Servicing Dealer. In some cases the muffler may need to be replaced to allow the spark arrester to be installed.

XI. Maintenance Intervals

Maintenance is one of the most important things that you can do to extend the life of your Tecumseh Engine. If you are unable to perform maintenance intervals yourself, contact your nearest Authorized Tecumseh Servicing Dealer. You may also call Tecumseh Power Company at 1-800-558-5402 or visit www.TecumsehPower.com to locate your dealer.

ALWAYS promptly follow maintenance intervals listed on the next two pages and see Table 7.

Table 7. Maintenance Intervals

Procedure	Time
Change Oil	After first 2 hrs. when engine is warm
Check Oil Level	5 hrs. or Before Each Use
Clean Cooling Fins	5 hrs. or Before Each Use
Change Oil	25 hrs. or 3 mos.
Clean Foam Pre-Filter	25 hrs. or 3 mos.
Replace Paper Element	100 hrs. or seasonally
Check Spark Plug	100 hrs. or seasonally
Replace Spark Plug	200 hrs. or seasonally

First Scheduled Maintenance

After First 2 Hours When Engine is Warm

1. Change Oil

Date _____ Owner/Dealer

Before Each Use Scheduled Maintenance

Every 5 Hours or Before Each Use

1. Check Oil Level
2. Clean Cooling Fins

Date _____ Owner/Dealer

Date _____ Owner/Dealer

Date _____ Owner/Dealer

Date _____ Owner/Dealer

Date _____ Owner/Dealer

Date _____ Owner/Dealer

Date _____ Owner/Dealer

Every 25 Hours or 3 Months Scheduled Maintenance

1. Change Oil
2. Clean Foam Pre-Filter

Date _____ Owner/Dealer

Date _____ Owner/Dealer

Date _____ Owner/Dealer

Date _____ Owner/Dealer

Date _____ Owner/Dealer

Date _____ Owner/Dealer

Date _____ Owner/Dealer

Date _____ Owner/Dealer

Date _____ Owner/Dealer

Date _____ Owner/Dealer

Date _____ Owner/Dealer

Date _____ Owner/Dealer

Date _____ Owner/Dealer

Date _____ Owner/Dealer

Date _____ Owner/Dealer

Date _____ Owner/Dealer

Date _____ Owner/Dealer

Date _____ Owner/Dealer

Date _____ Owner/Dealer

Date _____ Owner/Dealer

Date _____ Owner/Dealer

Date _____ Owner/Dealer

Date _____ Owner/Dealer

Date _____ Owner/Dealer

Date _____ Owner/Dealer

Date _____ Owner/Dealer

Date _____ Owner/Dealer

Date _____ Owner/Dealer

Date _____ Owner/Dealer

Date _____ Owner/Dealer

Date _____ Owner/Dealer

Date _____ Owner/Dealer

Date _____ Owner/Dealer

Date _____ Owner/Dealer

Date _____ Owner/Dealer

Date _____ Owner/Dealer

Date _____ Owner/Dealer

Date _____ Owner/Dealer

Date _____ Owner/Dealer

Date _____ Owner/Dealer

Date _____ Owner/Dealer

CALIFORNIA & US EPA EMISSION CONTROL WARRANTY STATEMENT

The U. S. Environmental Protection Agency (“EPA”), the California Air Resources Board (“CARB”) and Tecumseh Power Company are pleased to explain the Federal and California Emission Control Systems Warranty on your new small off-road engine. In California, new 1995 and later small off-road engines must be designed, built and equipped to meet the State’s stringent anti-smog standards. In other states, new 1997 and later model year engines must be designed, built and equipped, at the time of sale, to meet the U.S. EPA regulations for small non-road engines. Tecumseh Power Company will warrant the emission control system on your small off-road engine for the periods of time listed below, provided there has been no abuse, neglect, unapproved modification, or improper maintenance of your small off-road engine.

Your emission control system may include parts such as the carburetor, air cleaner assembly, ignition system, exhaust system, crankcase breather assembly and, the evaporative control system. Also included may be the compression release system and other emission-related assemblies.

Where a warrantable condition exists, Tecumseh Power Company will repair your small off-road engine at no cost to you for diagnosis, parts and labor.

MANUFACTURER’S EMISSION CONTROL SYSTEM WARRANTY COVERAGE

Emission control systems on 1995 and later model year California small off-road engines are warranted for two years as hereinafter noted. In other states, 1997 and later model year engines are also warranted for two years. If, during such warranty period, any emission-related part on your engine is defective in materials or workmanship, the part will be repaired or replaced by Tecumseh Power Company

OWNER’S WARRANTY RESPONSIBILITIES

As the small off-road engine owner, you are responsible for the performance of the required maintenance listed in your Operator’s Manual, but Tecumseh Power Company will not deny warranty solely due to the lack of receipts or for your failure to provide written evidence of the performance of all scheduled maintenance.

As the small off-road engine owner, you should, however, be aware that Tecumseh Power Company may deny you warranty coverage if your small off-road engine or a part thereof has failed due to abuse, neglect, improper maintenance or unapproved modifications.

You are responsible for presenting your small off-road engine to a Tecumseh Authorized Service Outlet (any Tecumseh Registered Service Dealer, Tecumseh Authorized Service Distributor or Tecumseh Central Warehouse Distributor) as soon as a problem exists. The warranty repairs should be completed in a reasonable amount of time, not to exceed 30 days.

Warranty service can be arranged by contacting either an Authorized Tecumseh Servicing Dealer and/or Tecumseh Power Company, c/o Service Manager, 900 North Street, Grafton, WI 53024-1499. Telephone 1-262-377-2700 [or in USA/Canada call 1-800-558-5402].

IMPORTANT NOTE

This warranty statement explains your rights and obligations under the Emission Control System Warranty (“ECS Warranty”) which is provided to you by Tecumseh Power Company pursuant to California law. Tecumseh Power Company also provides to original purchasers of new Tecumseh Power Company engines the Tecumseh Power Company Limited Warranties for New Tecumseh Engines and Electronic Ignition Modules. The Tecumseh Power Company Limited Warranties for New Tecumseh Engines and Electronic Ignition Modules (“Tecumseh Power Company Warranty”) are located on the back cover of the Operator’s Manual, enclosed with all new Tecumseh Power Company engines. The ECS Warranty applies only to the emission control system of your new engine. To the extent that there is any conflict in terms between the ECS Warranty and the Tecumseh Power Company Warranty, the ECS Warranty shall apply except in any circumstances in which the Tecumseh Power Company Warranty may provide a longer warranty period. Both the ECS Warranty and the Tecumseh Power Company Warranty describe important rights and obligations with respect to your new engine.

Warranty service can only be performed by a Tecumseh Power Company Authorized Servicing Dealer. At the time of requesting warranty service, evidence must be presented of the date of sale to the original purchaser. The purchaser shall pay any charges for making service calls and/or for transporting the products to and from the place where the inspection and/or warranty work is performed. The purchaser shall be responsible for any damage or loss incurred in connection with the transportation of any engine or any part(s) thereof submitted for inspection and/or warranty work.

If you have any questions regarding your warranty rights and responsibilities, you should contact Tecumseh Power Company at 1-262-377-2700 or in USA/Canada call 1-800-558-5402.

Revised July, 2005

IMPORTANT!

The emission Regulations may be different for your country. The emissions Control Warranty Statement is only applicable to engines with an emissions compliance statement and decal that references “Emissions Regulations”.

EMISSION CONTROL SYSTEM WARRANTY

Emission Control System Warranty ("ECS Warranty") for 1995 and later model year California small off-road engines (for other states, 1997 and later model year engines):

A. APPLICABILITY: This warranty shall apply to 1995 and later model year California small off-road engines (for other states, 1997 and later model year engines). The ECS Warranty Period shall begin on the date the new engine or equipment is delivered to its original, end-use purchaser, and shall continue for 24 consecutive months thereafter.

B. GENERAL EMISSIONS WARRANTY COVERAGE:

Tecumseh Power Company warrants to the original, end-use purchaser of the new engine or equipment and to each subsequent purchaser that each of its small off-road engines is:

1. Designed, built and equipped so as to conform with all applicable regulations adopted by the Air Resources Board pursuant to its authority in Chapters 1 and 2, Part 5, Division 26 of the Health and Safety Code, and
2. Free from defects in materials and workmanship which, at any time during the ECS Warranty Period, will cause a warranted emissions-related part to fail to be identical in all material respects to the part as described in the engine manufacturer's application for certification.

C. THE ECS WARRANTY ONLY PERTAINS TO EMISSION-RELATED PARTS ON YOUR ENGINE AS FOLLOWS:

1. Any warranted, emissions-related parts which are not scheduled for replacement as required maintenance in the Operator's Manual shall be warranted for the ECS Warranty Period. If any such part fails during the ECS Warranty Period, it shall be repaired or replaced by Tecumseh Power Company according to Subsection 4 below. Any such part repaired or replaced under the ECS Warranty shall be warranted for any remainder of the ECS Warranty Period.
2. Any warranted, emissions-related part which is scheduled only for regular inspection as specified in the Operator's Manual shall be warranted for the ECS Warranty Period. A statement in such written instructions to the effect of "repair or replace as necessary", shall not reduce the ECS Warranty Period. Any such part repaired or replaced under the ECS Warranty shall be warranted for the remainder of the ECS Warranty Period.
3. Any warranted, emissions-related part which is scheduled for replacement as required maintenance in the Operator's Manual, shall be warranted for the period of time prior to the first scheduled replacement point for that part. If the part fails prior to the first scheduled replacement, the part shall be repaired or replaced by Tecumseh Power Company according to Subsection 4 below. Any such emissions-related part repaired or replaced under the ECS Warranty, shall be warranted for the remainder of the ECS Warranty Period prior to the first scheduled replacement point for such emissions-related part.
4. Repair or replacement of any warranted, emissions-related part under this ECS Warranty shall be performed at no charge to the owner at a Tecumseh Authorized Service Outlet.

5. The owner shall not be charged for diagnostic labor which leads to the determination that a part covered by the ECS Warranty is in fact defective, provided that such diagnostic work is performed at a Tecumseh Authorized Service Outlet.
6. Tecumseh Power Company shall be liable for damages to other original engine components or approved modifications proximately caused by a failure under warranty of an emission-related part covered by the ECS Warranty.
7. Throughout the ECS Warranty Period, Tecumseh Power Company shall maintain a supply of warranted emission-related parts sufficient to meet the expected demand for such emission-related parts.
8. Any Tecumseh Power Company authorized and approved emission-related replacement part may be used in the performance of any ECS Warranty maintenance or repair and will be provided without charge to the owner. Such use shall not reduce Tecumseh Power Company ECS Warranty obligations.
9. Unapproved add-on or modified parts may not be used to modify or repair a Tecumseh Power Company engine. Such use voids this ECS Warranty and shall be sufficient grounds for disallowing an ECS Warranty claim. Tecumseh Power Company shall not be liable hereunder for failures of any warranted parts of a Tecumseh Power Company engine caused by the use of such an unapproved add-on or modified part.

EMISSION-RELATED PARTS INCLUDE THE FOLLOWING:

1. Carburetor Assembly including internal components:
 - a) Carburetor gaskets
 - b) Intake pipe
2. Air Cleaner Assembly including components:
 - a) Air filter element
3. Ignition System including components:
 - a) Spark plug
 - b) Ignition module
 - c) Flywheel assembly
4. Exhaust System including components:
 - a) Catalytic muffler (*if so equipped*)
 - b) Muffler gasket (*if so equipped*)
 - c) Exhaust manifold (*if so equipped*)
5. Crankcase Breather Assembly including components
 - a) Breather connection tube
6. Evaporative Control System including components:
 - a) Fuel line(s)
 - b) Fuel filter
 - c) Canister (*if so equipped*)
 - d) Fuel tank (*if so equipped*)
 - e) Fuel fill cap (*if so equipped*)

Revised July, 2005

IMPORTANT!

The emission Regulations may be different for your country. The emissions Control Warranty Statement is only applicable to engines with an emissions compliance statement and decal that references "Emissions Regulations".

XII. Warranty Information

Warranty requirements for engines sold outside of the USA may vary from country to country. For warranty details for your specific country, contact your national Tecumseh Service Distributor. If help is needed in locating your national service distributor, you may contact Tecumseh c/o International Service Coordinator, 900 North Street, Grafton, Wisconsin USA 53024-1499. Telephone is 1-262-377-2700 or in USA/Canada call 1-800-558-5402.

Limited Warranty for New Tecumseh Engines and Electronic Ignition Modules

For the time period shown below from the date of purchase, Tecumseh Power Company will, at its option as the exclusive remedy, either repair or replace for the original purchaser, free of charge, any part of any new Tecumseh engine which is found, upon examination by any Authorized Tecumseh Servicing Dealer to be DEFECTIVE IN MATERIAL AND/OR WORKMANSHIP, except as provided below. This Limited Warranty DOES NOT COVER (i) any Tecumseh engine or part(s) thereof used to power any vehicle in competitive racing and/or used on any commercial or rental track, or (ii) defects or damage caused by alterations or modifications of new Tecumseh engines or parts or by normal wear, accidents, improper maintenance, improper use or abuse of the product, or failure to follow the instructions contained in an Instruction Manual for the operation of the new Tecumseh engine or part. The cost of normal maintenance or replacement of service items which are not defective shall be paid for by the original purchaser. At the time warranty service is requested, evidence must be presented of the date of purchase by the original purchaser. Any charge for making service calls and/or for transporting any engine or part(s) thereof to and from the place where the inspection and/or warranty work is performed is payable solely by the purchaser. The purchaser is responsible for any damage or loss incurred in connection with the transportation of any engine or part(s) thereof submitted for inspection and/or warranty work. Warranty service can only be performed by an Authorized Tecumseh Servicing DEALER. Warranty service can be arranged by contacting either a Tecumseh Authorized Service Outlet (any Tecumseh Registered Service Dealer, Tecumseh Master Service Dealer, Tecumseh Authorized Service Distributor, or Tecumseh Central Warehouse Distributor) or by contacting Tecumseh c/o Service Manager, 900 North Street, Grafton, Wisconsin 53024-1499.

ENGINE WARRANTY PERIOD

Consumer Use+

WARRANTY CATEGORY~	WITHIN USA & CANADA	OUTSIDE USA & CANADA
(A)	90 day	90 day
(B)	1 year	1 year
(C)	2 years	1 year
(D)	2 years	2 years**
(E)	2 years	2 years
(H)	2 'n 10*	2 'n 10*
(K)	2 'n 10*	2 'n 10*

Commercial Use++

WARRANTY CATEGORY~	WITHIN USA & CANADA	OUTSIDE USA & CANADA
(A)	No Warranty	No Warranty
(B)	1 year	1 year
(C)	1 year	1 year
(D)	1 year	1 year
(E)	1 year	1 year
(H)	1 year	1 year
(K)	2 'n 10*	1 year

- * 2 years on engine, 10 years (the first 5 years covering parts and labor only; the second 5 years covering parts only) on electronic ignition.
- ** 1 year for Australian/New Zealand for rotary mower engines.
- + For purposes of this warranty policy, "consumer use" shall mean consumer's personal, residential, household use by the original retail purchaser.
- ++ For purposes of this warranty policy, "commercial use" shall mean all other uses, including use for commercial, income producing, or rental purposes.
- ~ The engine warranty category of your engine can be determined by review of the engine model number on the "Important Engine Information" decal. One letter in the engine model number will be preceded by the word WARRANTY: and surrounded by parens (A), (B), (C), (D), (E), (H) or (K) and that letter is your engine warranty category designation. IN CALIFORNIA ONLY, THIS EXPRESS WARRANTY IS SUPPLEMENTED BY THE TECUMSEH CALIFORNIA EMISSION CONTROL WARRANTY STATEMENT.

THIS EXPRESS WARRANTY IS IN LIEU OF ALL OTHER EXPRESS WARRANTIES. Neither Tecumseh nor any of its affiliates makes any warranties, representations, or promises, written or oral, as to the quality of the engine or any of its parts, other than as set forth herein. **ANY IMPLIED WARRANTY OF MARKETABILITY OR FITNESS FOR A PARTICULAR PURPOSE, TO THE EXTENT THAT EITHER MAY APPLY TO ANY TECUMSEH ENGINE OR PART(S) THEREOF, SHALL BE LIMITED IN DURATION TO THE PERIODS OF THE EXPRESS WARRANTIES SHOWN IN THE WARRANTY PERIOD CHART ABOVE AND TO THE EXTENT PERMITTED BY LAW AND ANY AND ALL IMPLIED WARRANTIES ARE EXCLUDED. IN NO EVENT WILL TECUMSEH BE LIABLE FOR ANY INCIDENTAL, CONSEQUENTIAL OR SPECIAL DAMAGES AND/OR EXPENSES.** Some states do not allow limitations on how long an implied warranty lasts or the exclusion or limitation of incidental or consequential damages, so the above limitation(s) or exclusion(s) may not apply to you. This Limited Warranty gives you specific legal rights and you may also have other legal rights which vary from state-to-state.

Revised January, 2004

WARNING CALIFORNIA PROPOSITION 65

The engine exhaust from this product contains chemicals known to the State of California to cause cancer, birth defects or other reproductive harm.

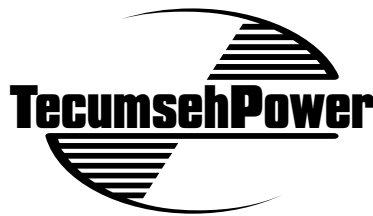

Tecumseh Power Company • Grafton, Wisconsin 53024-1499 • USA
Telephone: 1-800-558-5402

Visit us at: www.TecumsehPower.com

181-1269-14
(English) 1/01/08

Free Manuals Download Website

<http://myh66.com>

<http://usermanuals.us>

<http://www.somanuals.com>

<http://www.4manuals.cc>

<http://www.manual-lib.com>

<http://www.404manual.com>

<http://www.luxmanual.com>

<http://aubethermostatmanual.com>

Golf course search by state

<http://golfingnear.com>

Email search by domain

<http://emailbydomain.com>

Auto manuals search

<http://auto.somanuals.com>

TV manuals search

<http://tv.somanuals.com>