

---

# Operator's Manual

---

## TH098SA/TH139SA/TH139SP (HSK600-870)

Two-Cycle Engine • Horizontal/Vertical Crankshaft • Air-Cooled

### Table of Contents

IMPORTANT NOTICE! Safety Definitions.....	ii
I. General Safety Precautions .....	1
II. How to Get Service .....	3
III. Oil and Fuel Specifications.....	4
IV. Before Starting Your Engine.....	4
V. Starting Your Engine .....	5
VI. Stopping Your Engine and Short-Term Storage .....	9
VII. Maintenance .....	11
VIII. Transporting Your Engine.....	13
IX. Storing Your Engine .....	13
X. Preventing Forest, Brush and Grass Fires.....	15
XI. Maintenance Intervals .....	16
California & US EPA Emission Control Warranty Statement.....	20
Emission Control System Warranty .....	21
XII. Warranty Information.....	22

Visit our web site at [www.TecumsehPower.com](http://www.TecumsehPower.com)

- ◆ Register Your TecumsehPower Engine
- ◆ Maintenance Tips
- ◆ On-Line Store
- ◆ Locate your nearest TecumsehPower Servicing Dealer

LOG ON!

**181-807-14**  
**(English) 6/01/08**

# IMPORTANT NOTICE!

## Safety Definitions

Statements in this manual preceded by the following words and graphics are of special significance:

### **WARNING**

Or

### **WARNING**

WARNING indicates a potentially hazardous situation which if NOT avoided, could result in death or serious injury.

### **CAUTION**

Indicates a potentially hazardous situation which, if NOT avoided, may result in minor or moderate injury.

### **CAUTION**

Indicates a potential situation which, if NOT avoided, could result in equipment or property damage.

### *NOTE*

*Refers to important information and is placed in italic type.*

It is recommended that you take special notice of all items discussed on the next two pages and wear the appropriate safety equipment.

Before operating this engine *it is your responsibility* to read this Operator's Manual. Follow these basic rules for your personal safety:

- Keep this manual handy at all times for future reference.
- Read it carefully and familiarize yourself with operating, maintenance, components and safety instructions.

## Notice Regarding Emissions

### *NOTE*

*Engines which are certified to comply with California and U.S. EPA emission regulations for SORE (Small Off Road Equipment), are certified to operate on regular unleaded gasoline, and may include the following emission control systems: (EM) Engine Modification and (TWC) Three-way Catalyst (if so equipped).*

## TecumsehPower Contact Information

For engine adjustments, repairs or warranty service NOT covered in this manual, contact your nearest Authorized TecumsehPower Servicing Dealer. Find them on our website at [www.TecumsehPower.com](http://www.TecumsehPower.com) or call TecumsehPower Company at 1-800-558-5402 for additional information.

The trademarks TECUMSEH® and the DESIGN (Native American Head logo) are registered trademarks of Tecumseh Products Company and are used by TecumsehPower Company under license from Tecumseh Products Company. TecumsehPower Company is no longer owned by Tecumseh Products Company nor is it associated or affiliated in any way with Tecumseh Products Company.

©Copyright 2006, 2008

TecumsehPower Company

All Rights Reserved

# I. General Safety Precautions

## ⚠ WARNING

Read equipment manufacturer's manual and this material thoroughly before using this engine. Failure to do so can result in serious injury or death. Consult your local Authorized TecumsehPower Servicing Dealer, call 1-800-558-5402, or go to [www.TecumsehPower.com](http://www.TecumsehPower.com) for additional information.

### A. Avoid Carbon Monoxide Poisoning

All engine exhaust contains carbon monoxide, a deadly gas. Breathing carbon monoxide can cause headaches, dizziness, drowsiness, nausea, confusion and eventually death.

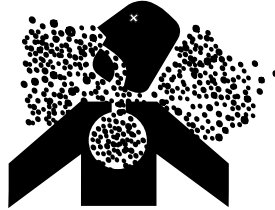

Carbon monoxide is a colorless, odorless, tasteless gas which may be present even if you DO NOT see or smell any engine exhaust. Deadly levels of carbon monoxide can collect rapidly and you can quickly be overcome and unable to save yourself. Also, deadly levels of carbon monoxide can linger for hours or days in enclosed or poorly-ventilated areas. If you experience any symptoms of carbon monoxide poisoning, leave the area immediately, get fresh air, and SEEK MEDICAL TREATMENT.

To prevent serious injury or death from carbon monoxide:

- NEVER run engine indoors. Even if you try to ventilate engine exhaust with fans or open windows and doors, carbon monoxide can rapidly reach dangerous levels.
- NEVER run engine in poorly-ventilated or partially enclosed areas such as barns, garages, basements, carports, under dwellings, or in pits.
- NEVER run engine outdoors where engine exhaust can be drawn into a building through openings such as windows and doors.

### B. Avoid Gasoline Fires

Gasoline (fuel) vapors are highly flammable and can explode. Fuel vapors can spread and be ignited by a spark or flame many feet away from engine. To prevent injury or death from fuel fires, follow these instructions:



- NEVER store engine with fuel in fuel tank inside a building with potential sources of ignition such as hot water and space heaters, clothes dryers, electric motors, etc.
- NEVER remove fuel fill cap or add fuel when engine is running.
- NEVER start or operate the engine with the fuel fill cap removed.
- Allow engine to cool before refueling.

- NEVER fill fuel tank indoors. Fill fuel tank outdoors in a well-ventilated area.
- DO NOT smoke while refueling tank.
- Use only an approved red GASOLINE container to store and dispense fuel. TecumsehPower Company recommends purchasing gasoline in containers with a capacity of 2.5 gallons or less. Small containers are easier to handle and help eliminate spillage during refueling.
- DO NOT pour fuel from engine or siphon fuel by mouth. To empty the fuel tank, see "I. Draining Fuel" instructions on page 14.

### C. Adult Supervision of Operation, Refueling and Maintenance

The manufacturer of the equipment may provide information about who is allowed to use this engine (see equipment manufacturer's manual). NOT everyone who is allowed to use this engine is capable of safely and responsibly operating, maintaining and/or fueling it. TecumsehPower Company recommends the following:

- An adult should fuel this engine. NEVER allow children to refuel this engine. See "B. Filling Fuel Tank" instructions on page 5.
- An adult should perform maintenance on this engine. See "VII. Maintenance" instructions on page 11. Only allow children to perform maintenance if an adult has determined they are experienced and capable of such operation.
- An adult should start the engine. See "G. Avoid Accidental Starts" instructions on page 2. Only allow children to start the engine if an adult has determined they are experienced and capable of such operation.
- To avoid unsupervised operation of the engine, especially by children, NEVER leave it unattended when it is running. Remove ignition key, if equipped.

### D. Stay Away from Rotating Parts

NEVER operate the engine with an unguarded engine shaft or flywheel. See Figure 1 on page 2.

The equipment manufacturer may attach a sprocket and chain or pulley and belt to the engine shaft. If these parts are NOT properly guarded, or if you are NOT sure whether they are properly guarded, DO NOT use your engine; contact the equipment manufacturer. Hands, feet, hair, jewelry, clothing, etc., can become entangled in rotating parts, leading to serious injury or death. To avoid serious injury or death, be sure the flywheel guard is in place. See Figure 1 on page 2.

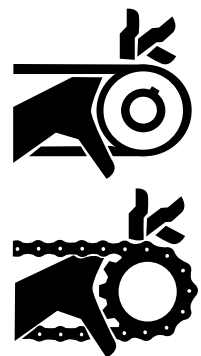

## E. DO NOT Modify Engine

To avoid serious injury or death, DO NOT modify engine in any way. Tampering with the governor setting can lead to a runaway engine and cause it to operate at unsafe speeds. NEVER tamper with factory setting of engine governor.

### ⚠ WARNING

Use of this engine on fun-carts, go-karts, or mini-bikes can result in serious injury or death. TecumsehPower Company manufactures the Power Sport line of engines for use in such applications. Consult your local Authorized TecumsehPower Servicing Dealer, call 1-800-558-5402, or visit [www.TecumsehPower.com](http://www.TecumsehPower.com) for additional information.

## F. Avoid Burns and Fire from Hot Surfaces

The muffler and other engine parts become extremely hot during operation and remain hot after the engine has stopped.



- To avoid severe burns on contact, STAY AWAY from hot areas of engine. DO NOT operate the engine without the muffler guard in place, if equipped.
- To reduce the risk of fire keep all materials that can burn, including grass and leaves, away from muffler and rest of engine. DO NOT operate, idle or park engine powered equipment in long dry grass or other dry ground cover.

## G. Avoid Accidental Starts

To prevent accidental starting when working on equipment always:

- Carefully disconnect spark plug wire and keep it away from spark plug. See Figures 2 and 3.
  - Keep the disconnected spark plug wire securely away from metal parts where arcing could occur.
  - Carefully attach the spark plug wire to the grounding post, if provided.
- Disconnect battery at negative terminal first, if engine is equipped with a DC electric starter.
- Turn all engine switches to “OFF” position.
- Remove ignition key, if provided.

## H. Use Hearing Protection

Engine noise may cause hearing damage. Always wear hearing protection when operating an engine.

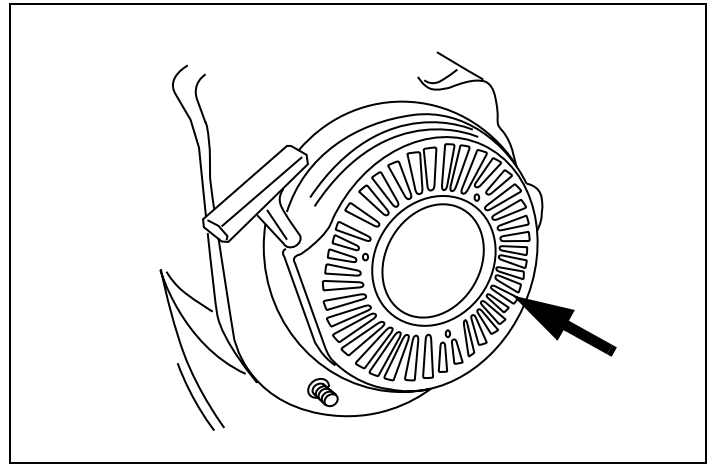

Figure 1. DO NOT Use Without Flywheel Guard

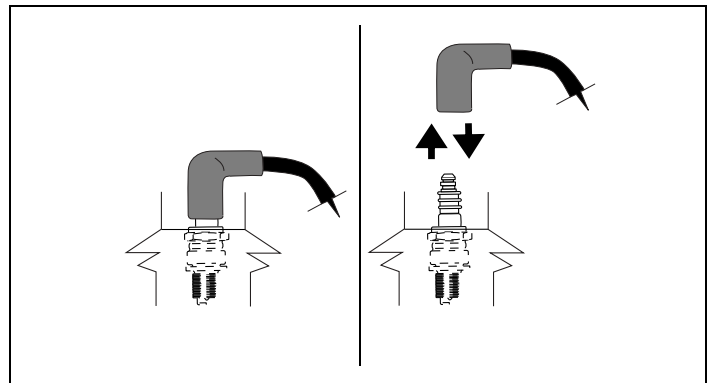

Figure 2. Disconnecting/Connecting Spark Plug

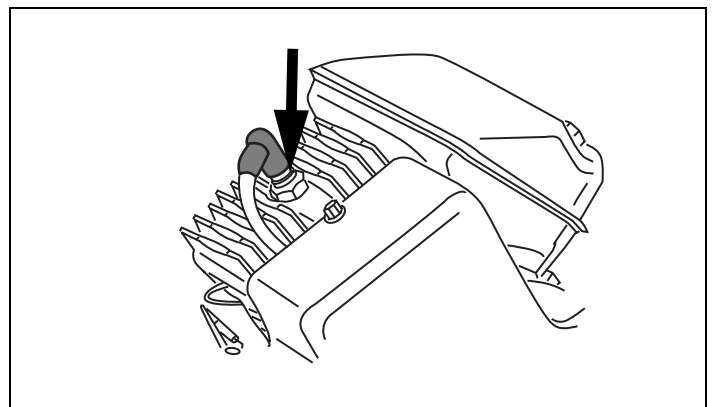

Figure 3. Typical Spark Plug Connection

## II. How to Get Service

For engine adjustments, repairs or warranty service NOT covered in this manual, contact your nearest Authorized TecumsehPower Servicing Dealer. Find them on our website at [www.TecumsehPower.com](http://www.TecumsehPower.com) or call TecumsehPower Company at 1-800-558-5402 for additional information.

Visit our web site at [www.TecumsehPower.com](http://www.TecumsehPower.com)

- ♦ Register Your TecumsehPower Engine
- ♦ Maintenance Tips
- ♦ On-Line Store
- ♦ Locate your nearest TecumsehPower Servicing Dealer

LOG ON!

### A. Engine Identification Decal

A sample engine identification decal is located in the next column and indicates the engine's model number, specification and date of manufacture (DOM). See Figure 4.

#### NOTES

Please look at the decal on your engine.

Fill in the engine information in the spaces provided for future reference.

The engine identification decal also includes engine life specifications for the emissions-related useful life period of your engine. This period relates to the emission compliance life as certified by EPA and/or CARB.

- TH models are designated as "C" 50 hours, "B" 125 hours, "A" 300 hours.

### B. Technician's Handbook

If you have a general understanding of internal combustion engines and wish to repair and service your engine and/or engine emission control systems yourself, a Technician's Handbook is available from your Authorized TecumsehPower Servicing Dealer. See Figure 5. This handbook covers repairs and adjustments not covered within this Operator's Manual, and it is intended for individuals who have had adequate training, experience and who practice proper tool usage. Service procedures should be clearly understood and practiced when servicing TecumsehPower engines.

- Order as part #694988 for TH models.

TecumsehPower Company manufactures and is responsible only for the engine used on this power equipment. If repair or service is needed for anything other than the engine, contact the service source recommended by the equipment manufacturer.



ENGINE  
MODEL: \_\_\_\_\_  
SPEC: \_\_\_\_\_  
DOM: \_\_\_\_\_

Figure 4. Engine Identification Decal



Figure 5. Technician's Handbook

### III. Oil and Fuel Specifications

#### A. Oil

To operate your engine you need to use a clean, high quality, 2-cycle oil mixed with fuel at a ratio of 50:1. For recommended mixture ratio of fuel and oil, see Tables 1 and 2. See "A. Mixing Fuel and Oil" instructions. Afterward, continue reading instructions below.

#### NOTES

Use of NMMA, TC-WII or TC-W3, JASO FB or FASO FC classified oil is recommended.

A 32:1 fuel mix ratio is recommended if NMMA oil is not available. See Table 2 and "A. Mixing Fuel and Oil" instructions. Afterward, continue reading instructions below.

Special-formulated oils are available at your Authorized TecumsehPower Servicing Dealer.

**Table 1. Fuel Mix Chart – Mixture Ratio 50:1**

U.S.		S.I. Metric	
Gas	Oil	Petrol	Oil
1 Gal.	2-1/2 oz.	4 Liters	80 ml
2 Gal.	5 oz.	8 Liters	160 ml
5 Gal.	13 oz.	20 Liters	400 ml

**Table 2. Fuel Mix Chart – Mixture Ratio 32:1**

U.S.		S.I. Metric	
Gas	Oil	Petrol	Oil
1 Gal.	4 oz.	4 Liters	125 ml
2 Gal.	8 oz.	8 Liters	250 ml
5 Gal.	20 oz.	20 Liters	625 ml

**Table 3. Recommended Fuel**

Fuel Component	Percentage
Ethanol	10%
Grain Alcohol ("Gasohol")	10%
MTBE (Methyl Tertiary Butyl Ether)	15%
ETBE (Ethyl Tertiary Butyl Ether)	15%

### B. Fuel

Use unleaded regular, unleaded premium or reformulated automotive fuel only. You may use gasoline containing the components identified in Table 3.

- DO NOT use leaded fuel.
- Fuel must be fresh and clean. NEVER use fuel left over from last season or stored for long periods.
- DO NOT use fuel containing Methanol (Wood Alcohol).

#### CAUTION

The use of alternative fuels such as E85 or E20 are NOT recommended for use in TecumsehPower engines. Alternative fuels with high alcohol content can cause hard starting, poor engine performance, and may cause internal engine damage.

#### NOTE

Damage and/or performance problems that occur from use of fuels other than those listed in the Operator's Manuals will not be considered warranty.

### IV. Before Starting Your Engine

#### A. Mixing Fuel and Oil

#### WARNING

NEVER store engine with fuel in the fuel tank inside a building with potential sources of ignition such as hot water or space heaters, clothes dryers, electric motors, etc. Doing so may lead to an explosion resulting in death or serious injury.

#### NOTES

DO NOT mix fuel and oil directly in fuel tank.

Use of NMMA, TC-WII or TC-W3, JASO FB or JASO FC classified oil is recommended.

A 32:1 fuel mix ratio is recommended if NMMA oil is not available. See Table 2.

TecumsehPower synthetic and special-formulated oils are available at your Authorized TecumsehPower Servicing Dealer.

1. Be sure container is outdoors and in a well-ventilated area.
2. Fill approved clean red GASOLINE container with 1/4 of recommended fuel amount. See Tables 1, 2 and 3.
3. Add required amount of recommended oil to fuel. See Tables 1 and 2.
4. Screw cap onto container.
5. Shake container vigorously.
6. Unscrew cap from container.
7. Fill container with remainder of recommended fuel. See Tables 1, 2 and 3.
8. Wipe away any spilled fuel or oil.

## B. Filling Fuel Tank

**WARNING** An adult should fuel this engine. NEVER allow children to refuel this engine. Gasoline (fuel) vapors are highly flammable and can explode. Fuel vapors can spread and be ignited by a spark or flame many feet away from engine. To prevent injury or death from fuel fires, follow these instructions:

1. Stop engine and allow it to cool before refueling.
2. Be sure engine is outdoors and in a well-ventilated area.
3. Clean area around fuel fill cap and remove fuel fill cap.

### NOTE

For recommended mixture ratios of fuel and oil, see Tables 1, 2 and 3 on page 4. See "III. Oil and Fuel Specifications" instructions on page 4. Afterward, continue reading instructions below.

4. Using an approved red GASOLINE container, add fuel mixture slowly, being careful to avoid spilling. DO NOT overfill fuel tank. Leave space in the tank to allow fuel to expand without overflowing.
5. Replace fuel fill cap securely and wipe up spilled fuel before starting engine. If fuel mixture is spilled DO NOT start engine. Move machine away from area of spillage. Avoid creating any source of ignition until fuel vapors are gone.

### NOTE

Replace a damaged or missing fuel fill cap only with a genuine TecumsehPower replacement Fuel Fill Cap. Failure to do so may **VOID YOUR WARRANTY**. See Figure 6.

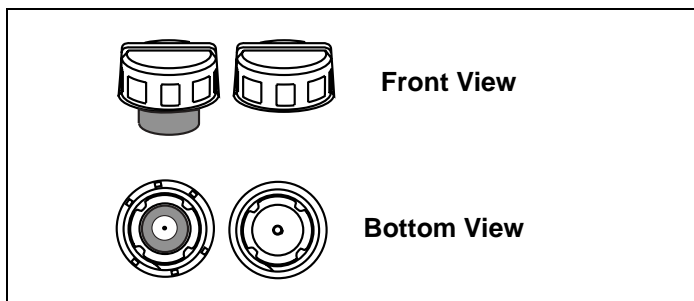

Figure 6. Possible Fuel Fill Cap(s)

## C. Check the Following Items

### NOTE

Be sure equipment is in **neutral** before attempting to start (see equipment manufacturer's instructions).

1. Be sure ignition switch on engine or equipment is in "ON", "RUN" or "START" position, if present (see equipment manufacturer's instructions).
2. Be sure air vent on fuel fill cap, if present (see equipment manufacturer's instructions) is free of debris. Be sure air vent screw, if present (see equipment manufacturer's instructions) on fuel fill cap is open.

## V. Starting Your Engine

**WARNING** To avoid serious injury or death, an adult should start this engine. Only allow children to start engine if an adult has determined they are experienced and capable of such operation.

**WARNING** If you are unable to start this engine after following instructions in this manual, contact your Authorized TecumsehPower Servicing Dealer. To avoid serious burn injuries or damage to your engine, DO NOT attempt to start or troubleshoot this engine in any other way. For example:

- DO NOT use starting fluid.
- DO NOT spray flammable vapors into carburetor.
- DO NOT put flammable liquids into carburetor.
- DO NOT operate engine or pull on starter rope with spark plug removed. Fuel can spray from spark plug hole and ignite.

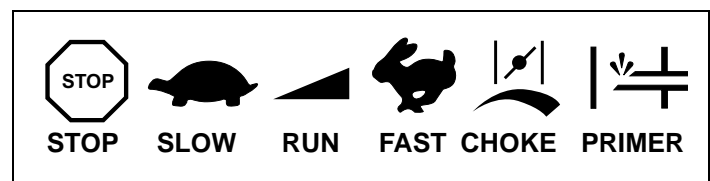

Figure 7. Typical Engine Symbols

### NOTE

If engine is remotely controlled (see equipment manufacturer's instructions) your equipment may have one or more of the following engine symbols. See Figure 7.

This section contains starting instructions for several different types of engines. In order to locate the instructions that apply to your engine, first determine what type of starter you have. If you have an electric starter, see "A. Engines with Electric Starters" instructions on page 6. If you have a manual recoil starter, see "B. Engines with Recoil Starters" instructions on page 8.

## A. Engines with Electric Starters

**WARNING** Some electric starters are equipped with a 120V AC Three-Wire Power Cord and Plug designed to operate on a 120V AC household current. It must be properly grounded at all times to avoid the possibility of injury or death from electrical shock.

- Determine if your house wiring has a Ground Fault Interrupted (GFI) Three-Wire Grounded System; If you are not sure ask a Licensed Electrician.
  - If your house wiring does not have a GFI Three-Wire Grounded System, **DO NOT USE THIS ELECTRIC STARTER UNDER ANY CONDITION.**
  - If your house wiring is grounded and a GFI Three-Prong Wall Receptacle is not available at the location where your starter will be used, one must be installed by a Licensed Electrician **BEFORE USING THE ELECTRIC STARTER.**
- To avoid carbon monoxide poisoning, be sure engine is outdoors in a well-ventilated area.

### NOTES

*If your engine is equipped with a 12V battery-operated electric starter, proceed to step 3.*

*When connecting power cord, always connect power cord to switch box on engine first; then into outlet. See Figure 8.*

*For European 220V AC applications use an appropriate grounded extension lead available locally.*

- Connect power cord to switch box on engine. See Figure 8.
- Plug end of power cord into outlet.
- Move choke control to "FULL CHOKE" position (see equipment manufacturer's instructions). See Figure 9 on page 7. Afterward, continue reading instructions below.
- Use equipment according to instructions listed in the table and notes below. See Table 4. See Figure 10 on page 7. Afterward, continue reading instructions below.

**Table 4. Priming Methods**

TH	
Above 32°F (0°C)	No priming required.
0°F to 32°F (-18°C to 0°C)	May require pushing primer bulb firmly with your thumb 3 times.
Below 0°F (-18°C)	May require pushing primer bulb firmly with your thumb 5 times.

### NOTES

*DO NOT use primer bulb to restart a warm engine after a short shutdown. Doing so will flood the engine and may result in equipment malfunction.*

*DO NOT operate an electric starter for more than 5 seconds each attempt.*

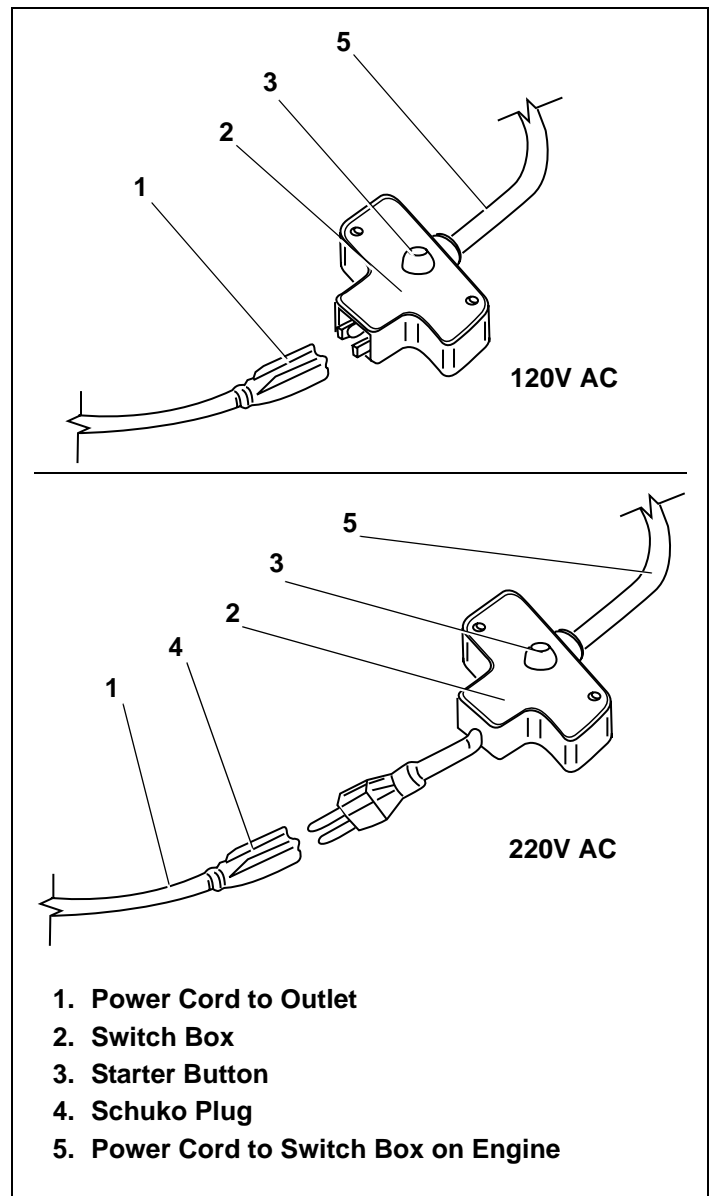

**Figure 8. Electrical Applications**



6. Push starter button or turn ignition switch key (see equipment manufacturer's instructions) to start engine.

**NOTE**

*If engine fails to start after 3 attempts repeat steps 2 thru 6.*

7. When engine starts:
  - a. Release starter button or ignition switch key.
  - b. Momentarily move choke control to "1/2 CHOKE" position until engine runs smoothly. See Figure 9.
  - c. Next, move choke control to "NO CHOKE" position. See Figure 9.

**NOTES**

*If engine starts but falters when choke control is moved to "NO CHOKE" position:*

- a. Momentarily move choke control back to "FULL CHOKE" position. See Figure 9.
- b. Next, move choke control to "1/2 CHOKE" position until engine runs smoothly.
- c. Finally, move choke control to "NO CHOKE" position.

*If engine dies after choke control is moved to "NO CHOKE" position repeat steps 2 thru 7 to restart engine.*

8. If engine fires but does not continue to run, move choke control to "NO CHOKE" position and start engine.
9. If engine fails to start after 3 attempts in the "NO CHOKE" position, move choke control to "FULL CHOKE" position and start engine.

**NOTE**

*When disconnecting power cord, always disconnect power cord from outlet first; then disconnect power cord from switch box on engine. See Figure 8 on page 6. Afterward, continue reading instructions below.*

10. Disconnect power cord from outlet.
11. Disconnect power cord from switch box on engine.
12. If engine does not start after following steps 1 thru 11, contact your Authorized TecumsehPower Servicing Dealer. DO NOT attempt to start or troubleshoot this engine in any other way.

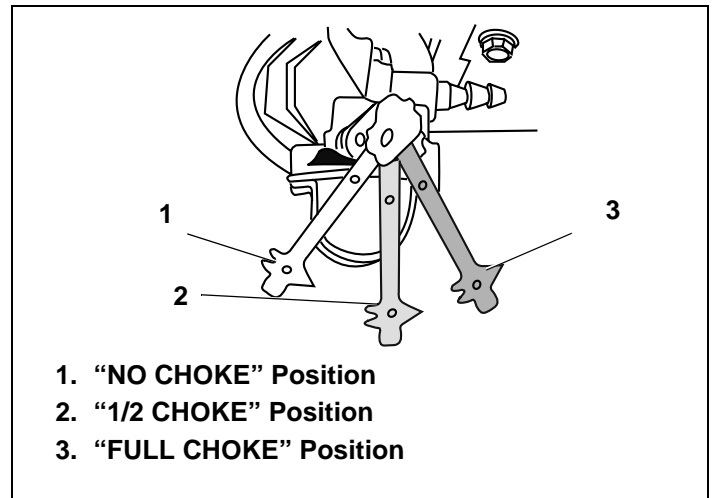

**Figure 9. Choke Control Positions**

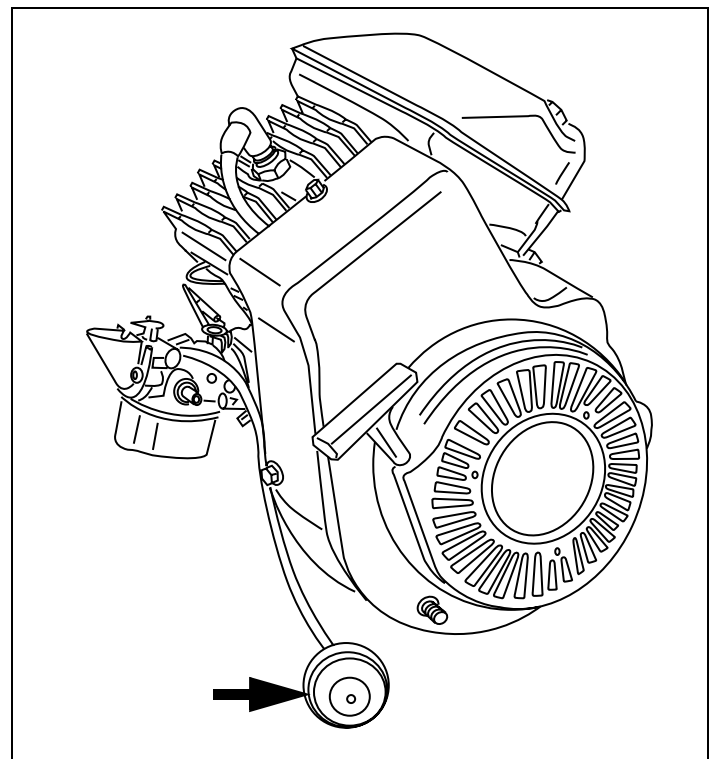

**Figure 10. Primer Bulb**

## B. Engines with Recoil Starters

If you have an electric starter, see "A. Engines with Electric Starters" instructions beginning on page 6.

1. To avoid carbon monoxide poisoning, be sure engine is outdoors in a well-ventilated area.
2. Move choke control to "FULL CHOKE" position (see equipment manufacturer's instructions). See Figure 12.
3. Use equipment according to instructions listed in the table and notes below. See Table 5. See Figure 10 on page 7. Afterward, continue reading instructions below.

**Table 5. Priming Methods**

TH	
Above 32°F (0°C)	No priming required.
0°F to 32°F (-18°C to 0°C)	May require pushing primer bulb firmly with your thumb 3 times.
Below 0°F (-18°C)	May require pushing primer bulb firmly with your thumb 5 times.

### NOTES

*DO NOT use primer bulb to restart a warm engine after a short shutdown. Doing so will flood the engine and may result in equipment malfunction.*

*DO NOT operate an electric starter for more than 5 seconds each attempt.*

4. Operate equipment control to release engine brake or clutch, if present (see equipment manufacturer's instructions).

### WARNING

When pulling starter rope, the rope can unexpectedly jerk back toward engine causing serious injury. To avoid this risk, carefully follow these instructions:

5. Grasp starter cord handle. See Figure 11.
  - a. Pull rope out slowly until you feel drag.
  - b. Without allowing the rope to retract, continue pulling rope with one rapid full arm stroke.
  - c. Return rope *slowly* to original position.

### NOTES

*Following the instructions listed in the steps above avoids potential damage to the recoil mechanism.*

*If recoil starter handle is frozen and will not operate engine, proceed as follows:*

- a. Pull as much rope out of starter as possible.
- b. Release starter handle and let it snap back against starter to break up ice; these two steps should **ONLY** be done **WHEN STARTER IS FROZEN**.

*If engine fails to start after 3 attempts, repeat steps 2 thru 5 and try again.*

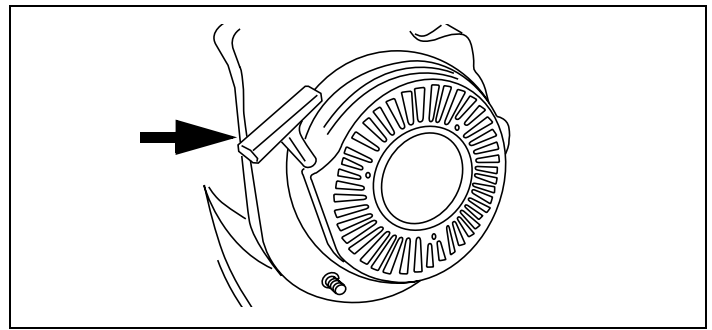

**Figure 11. Starter Cord Handle**

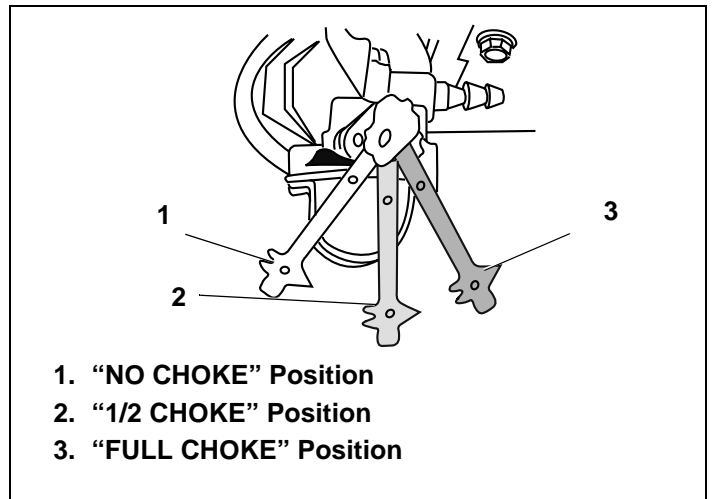

**Figure 12. Choke Control Positions**

6. When engine starts:
  - a. Release starter button or ignition switch key.
  - b. Momentarily move choke control to "1/2 CHOKE" position until engine runs smoothly. See Figure 12.
  - c. Next, move choke control to "NO CHOKE" position. See Figure 12.

### NOTES

*If engine starts but falters when choke control is moved to "NO CHOKE" position:*

- a. Momentarily move choke control back to "FULL CHOKE" position.
- b. Next, move choke control to "1/2 CHOKE" position until engine runs smoothly.
- c. Finally, move choke control to "NO CHOKE" position.

*If engine dies after choke control is moved to "NO CHOKE" position repeat steps 2 thru 6 to restart engine.*

7. If engine fires but does not continue to run, move choke control to "NO CHOKE" position and start engine.
8. If engine fails to start after 3 attempts in the "NO CHOKE" position, move choke control to "FULL CHOKE" position and start engine.
9. If engine does not start after following steps 1 thru 8, contact your Authorized TecumsehPower Servicing Dealer. DO NOT attempt to start or troubleshoot this engine in any other way.

## VI. Stopping Your Engine and Short-Term Storage

Stop engine according to equipment manufacturer's instructions.

**WARNING** To avoid unsupervised operation of an engine, especially by children, NEVER leave it unattended when it is running. Always turn off the engine after use and remove ignition key, if provided. Failure to do so may lead to serious injury or death.

**WARNING** NEVER store engine with fuel in the fuel tank inside a building with potential sources of ignition such as hot water or space heaters, clothes dryers, electric motors, etc. Doing so may lead to an explosion resulting in death or serious injury.

### A. Before Stopping

1. Run engine for a few minutes to help dry off any moisture on engine.
2. To help avoid possible freeze-up of starter proceed as follows:

#### I. Recoil Starters

With engine running, pull starter rope with a rapid continuous full arm stroke 3 or 4 times. See Figure 13.

#### NOTE

*The unusual sound made by pulling starter rope will not harm engine or starter.*

#### II. Electric Starters

#### NOTES

*When connecting power cord, always connect power cord to switch box on engine first; then into outlet. See Figure 14.*

*For European 220V AC applications use an appropriate grounded extension lead available locally.*

1. Connect power cord to switch box on engine.
2. Plug end of power cord into outlet.
3. With engine running, push starter button and spin starter for several seconds.

#### NOTES

*The unusual sound made by the spinning starter will not harm engine or starter.*

*When disconnecting power cord, always disconnect power cord from outlet first; then disconnect switch box on engine. See Figure 14.*

4. Disconnect power cord from outlet.
5. Disconnect switch box on engine.

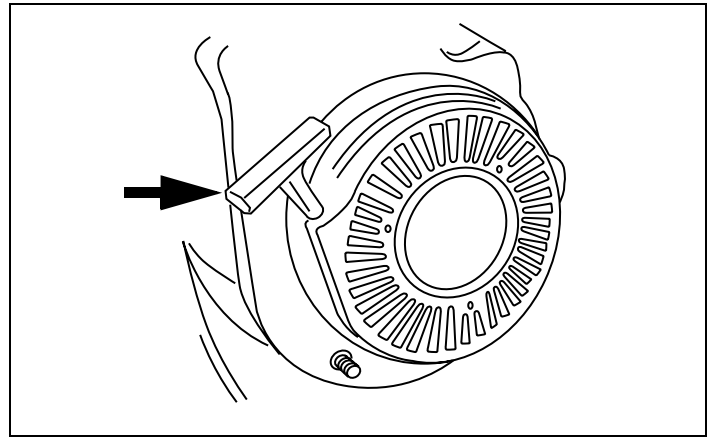

Figure 13. Starter Cord Handle

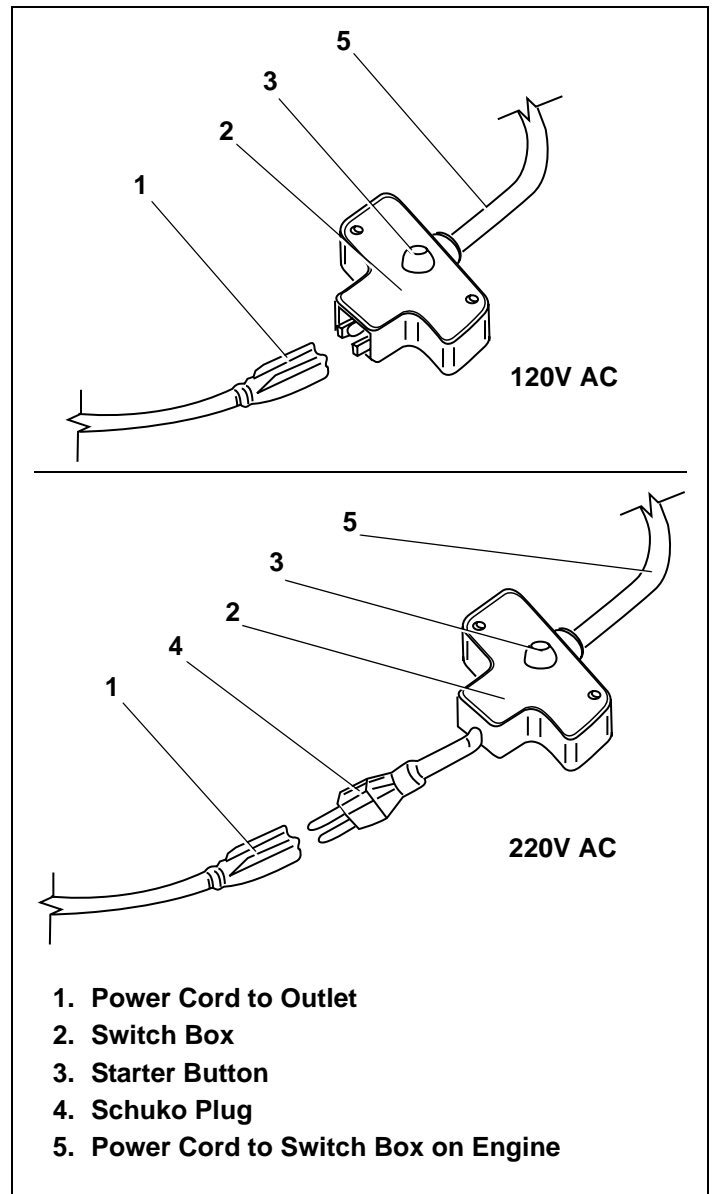

Figure 14. Electrical Applications

## B. Stop Engine

1. Move equipment control, if present (see manufacturer's instructions) engine control lever or ignition switch to "STOP" or "OFF" position.
2. Remove ignition key, if provided (see manufacturer's instructions).

### NOTE

Removing key will reduce the possibility of unauthorized starting of the engine while equipment is not in use.



### WARNING

NEVER store engine with fuel in the fuel tank inside a building with potential sources of ignition such as hot water or space heaters, clothes dryers, electric motors, etc. Doing so may lead to an explosion resulting in death or serious injury.

## C. After Engine is Stopped

### CAUTION

To prevent possible freeze-up of engine controls, follow instructions with engine stopped, listed below.

1. Wipe all snow and moisture from engine control lever and choke areas.
2. Move equipment control, if present (see manufacturer's instructions) engine control lever or ignition switch back and forth several times and leave control in "STOP" or "OFF" position.
3. Move engine choke back and forth several times and leave in the "FULL CHOKE" position. See Figure 15.

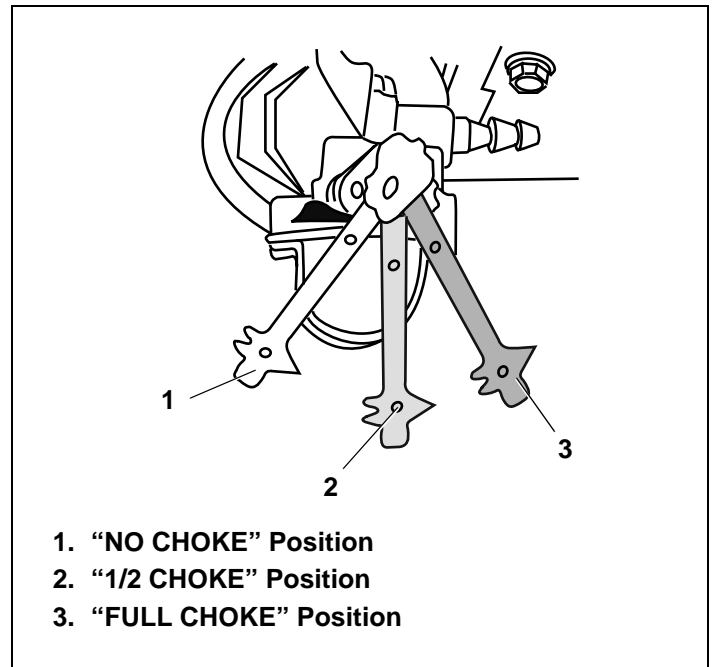

Figure 15. Choke Control Positions

## VII. Maintenance

**WARNING** To avoid serious injury or death, an adult should perform maintenance on this engine. Only allow children to perform maintenance if an adult has determined they are experienced and capable of such operation.

**WARNING** To prevent accidental starting when working on equipment, always:

- Carefully disconnect spark plug wire and keep it away from spark plug. See Figures 16 and 17.
  - Keep the disconnected spark plug wire securely away from metal parts where arcing could occur.
  - Carefully attach the spark plug wire to the grounding post, if provided.
- Disconnect battery at negative terminal first, if engine is equipped with a DC electric starter.
- Turn all engine switches to “OFF” position.
- Remove ignition key, if provided.

### NOTES

When disconnecting power cord, if present (see equipment manufacturer's instructions) always disconnect power cord from outlet first; then disconnect power cord from switch box on engine. See Figure 18.

When connecting power cord, always connect power cord to switch box on engine first; then into outlet. See Figure 18.

### A. Remote Choke

See equipment manufacturer's instructions and contact an Authorized TecumsehPower Servicing Dealer.

### B. Carburetor

If you think your carburetor needs adjusting, see your nearest Authorized TecumsehPower Servicing Dealer. Engine performance should not be affected at altitudes up to 7,000 feet (2,134 meters). For operation at higher elevations, contact an Authorized TecumsehPower Servicing Dealer.

### C. Engine Speed

**WARNING** To avoid serious injury or death, DO NOT modify engine in any way.

Tampering with the governor setting can lead to a runaway engine and cause it to operate at unsafe speeds. NEVER tamper with factory setting of engine governor.

Running the engine faster than the speed set at the factory can be dangerous and will **VOID THE ENGINE WARRANTY**.

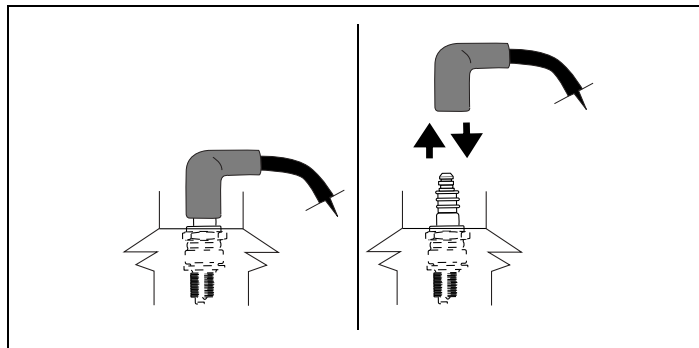

Figure 16. Disconnecting/Connecting Spark Plug

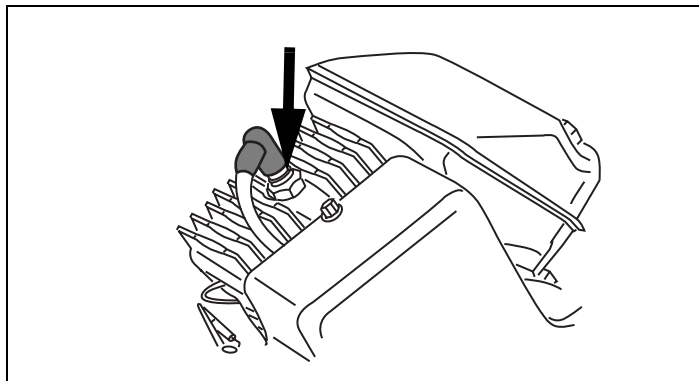

Figure 17. Typical Spark Plug Connection

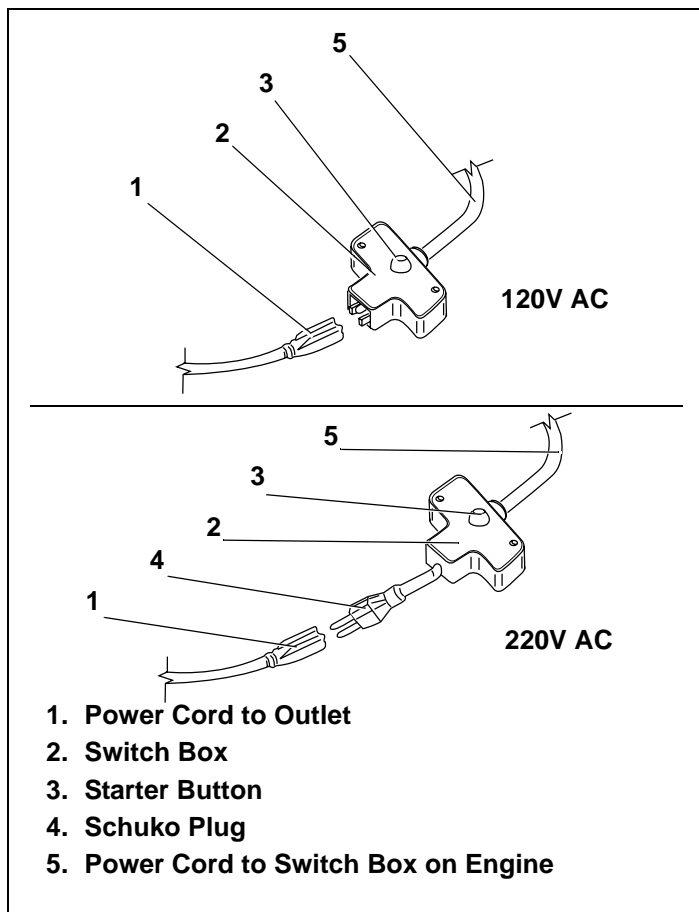

Figure 18. Electrical Applications

## D. Adjustments

DO NOT make any engine adjustments. Factory settings are satisfactory for most conditions. If adjustments are needed, contact your Authorized TecumsehPower Servicing Dealer.

## E. Muffler and Cylinder Exhaust Ports

The muffler and cylinder exhaust ports require cleaning after every 75 to 100 hours of operation.

### NOTE

For this maintenance procedure it is recommended that the engine be taken to an Authorized TecumsehPower Servicing Dealer.

## F. Spark Plug

Check spark plug yearly or every 100 operating hours.

1. Clean area around spark plug.
2. Remove and inspect spark plug.
3. Replace spark plug if porcelain is cracked or if electrodes are:
  - Pitted
  - Burned
  - Fouled with Deposits
4. Check electrode gap with wire feeler gauge and set gap to—.030 in. (0.76 mm) if necessary. See Figure 19.
5. Install spark plug and tighten securely.

### NOTE

A resistor spark plug must be used for replacement. Contact your Authorized TecumsehPower Servicing Dealer for a genuine replacement Resistor Spark Plug.

## G. Removing Snow from Engine

After each use remove snow from the following areas:

- Fuel Fill Cap
- Recoil Starter Screen
- Control Lever

### NOTES

See equipment manufacturer's instructions for proper location of fuel fill cap and control lever.

Removing snow will ease operation of the recoil starter rope and reduce the risk of water contamination when opening fuel fill cap. See Figure 20.

For more information about recoil starters, see "B. Engines with Recoil Starters" instructions on page 8.

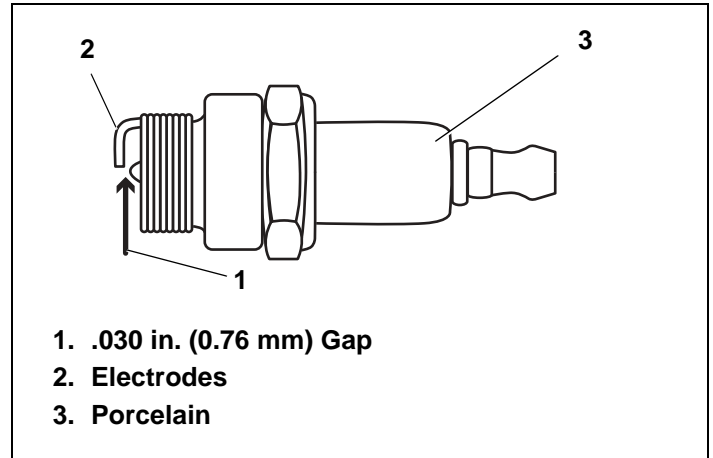

Figure 19. Resistor Spark Plug

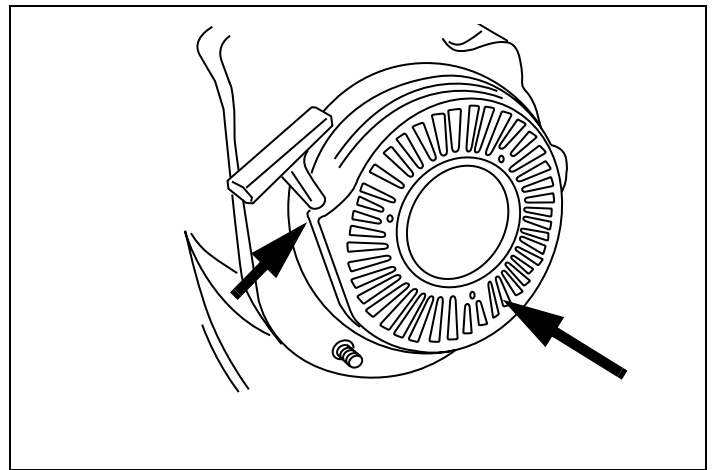



Figure 20. Recoil Starter Debris Areas

## VIII. Transporting Your Engine

 **WARNING** NEVER transport this engine inside another vehicle or in any enclosed space if there is any gasoline in the tank. Fuel vapor or spilled fuel may ignite leading to serious injury or death.

If there is fuel in the fuel tank, close the fuel shut-off valve, if equipped, and transport the engine upright in an open vehicle, such as an open trailer or open bed of a pickup truck.

If you DO NOT have an open vehicle and have to transport the engine upright in a closed vehicle, follow these steps for emptying the fuel tank before transporting:

1. Empty fuel tank by using a commercially available suction device designed for use with gasoline.

 **WARNING** To avoid serious injury or death, DO NOT pour fuel from engine or siphon fuel by mouth.

2. Drain fuel into an approved red GASOLINE container, being careful to avoid spilling.
3. Run the engine until remaining fuel is consumed.

 **WARNING** NEVER leave the engine unattended when it is running and NEVER run engine in enclosed areas to avoid death or serious injury.

## IX. Storing Your Engine

### A. Short-Term/Seasonal Storage

#### I. Clean Engine

Before servicing the engine remove the carburetor cover and/or blower housing. Remove dirt and debris from the following areas:

- Cooling Fins
- Air Intake Screen
- Levers
- Linkage
- Guards
- Carburetor
- Head

Removing debris will insure adequate cooling, correct engine speed and reduce the risk of fire.

#### II. Fuel Storage

 **WARNING** NEVER store engine with fuel in the fuel tank inside a building with potential sources of ignition such as hot water or space heaters, clothes dryers, electric motors, etc. Doing so may lead to an explosion resulting in death or serious injury.

#### NOTES

*If engine fuel stored in the gas tank and/or an approved gas container is to be unused without gasoline stabilizer for more than 15-30 days, prepare it for short-term/seasonal storage. See "IV. Fuel Treatment" instructions on page 14. Afterward, continue reading instructions below.*

*If engine fuel is to be stored for more than one season, without gasoline stabilizer, it will gradually deteriorate. Also, if it is stored in the engine's gas tank without gasoline stabilizer it is likely that your carburetor will have gum deposits, a clogged fuel system and **WILL VOID YOUR WARRANTY**. Prepare the fuel for extended storage. See "B. Extended Storage" instructions on page 14.*

### III. Fuel System

To avoid stale gas and carburetor problems, treat the fuel system in the following method below:

#### NOTES

*TecumsehPower Company recommends using ULTRA-FRESH™ Gasoline Stabilizer as an acceptable method of minimizing formation of fuel gum deposits during storage. This product is available from your Authorized TecumsehPower Servicing Dealer.*

*Always follow mix ratio found on stabilizer container. Failure to do so may result in equipment damage.*

*It is NOT necessary to drain stabilized gas from carburetor.*

### IV. Fuel Treatment

1. Add fuel stabilizer according to manufacturer's instructions.
2. Run engine at least 10 minutes after adding stabilizer to allow it to reach carburetor.

 **WARNING** NEVER store engine with fuel in the fuel tank inside a building with potential sources of ignition such as hot water or space heaters, clothes dryers, electric motors, etc. Doing so may lead to an explosion resulting in death or serious injury.

#### NOTE

*Instead of using a fuel preservative/stabilizer, you can empty the fuel tank as described under "I. Draining Fuel" instructions. See "B. Extended Storage" instructions.*

### B. Extended Storage

#### I. Draining Fuel

#### NOTES

*Clean debris from engine before draining fuel from carburetor. See "I. Clean Engine" instructions on page 13. Afterward, continue reading instructions below.*

*If you have prepared your fuel for short-term storage it is NOT necessary to drain fuel that contains stabilizer from your carburetor. See "A. Short-Term/Seasonal Storage" instructions on page 13. Afterward, continue reading instructions below.*

 **WARNING** To avoid severe injury or death, DO NOT pour fuel from engine or siphon fuel by mouth.

1. To prevent serious injury from fuel fires, empty fuel tank by running engine until it stops from lack of fuel. DO NOT attempt to pour fuel from engine.
2. Run the engine while waiting until the remaining fuel is consumed.

 **WARNING** NEVER leave the engine unattended when it is running and NEVER run engine in enclosed areas to avoid death or serious injury.

3. Begin servicing the cylinder bore. See "II. Oil Cylinder Bore" instructions on page 15.



## II. Oil Cylinder Bore

**CAUTION** When lubricating cylinder bore, fuel may spray from spark plug hole. To prevent serious injury from fuel fires, follow these instructions:

1. Carefully disconnect spark plug wire and keep it away from spark plug. See Figures 21 and 22.
  - Keep the disconnected spark plug wire securely away from metal parts where arcing could occur.
  - Carefully attach the spark plug wire to the grounding post, if provided.
  - Disconnect battery at negative terminal first, if engine is equipped with a DC electric starter.
  - Turn all engine switches to “OFF” position.
  - Remove ignition key, if provided.
2. Remove spark plug.
3. Squirt 1oz. (30 ml) of clean engine oil into spark plug hole.
4. Cover spark plug hole with rag to prevent fuel from spraying from spark plug hole when starter rope is pulled.

### NOTES

*For engines equipped with recoil starters proceed to Step 5.*

*For engines equipped with electric starters proceed to Step 6.*

5. Grasp starter cord handle:
  - a. Pull starter cord handle out slowly using a full arm stroke.
  - b. Repeat once. (This will distribute oil throughout the cylinder to prevent corrosion during storage.)
  - c. Proceed to Step 8.
6. Push starter button or turn ignition switch key to “START” position (see equipment manufacturer’s instructions) to cycle the engine for one to two seconds.
7. Turn ignition switch key to “OFF” position. Repeat Steps 6 and 7. (This will distribute oil throughout the cylinder to prevent corrosion during storage.)
8. Remove rag covering spark plug hole.
9. Install spark plug.
10. Carefully disconnect spark plug wire from grounding post, if provided.
11. Connect spark plug wire to spark plug before attempting to start engine.

## III. Battery

See equipment manufacturer’s instructions for proper battery storage if machine is equipped with a battery.

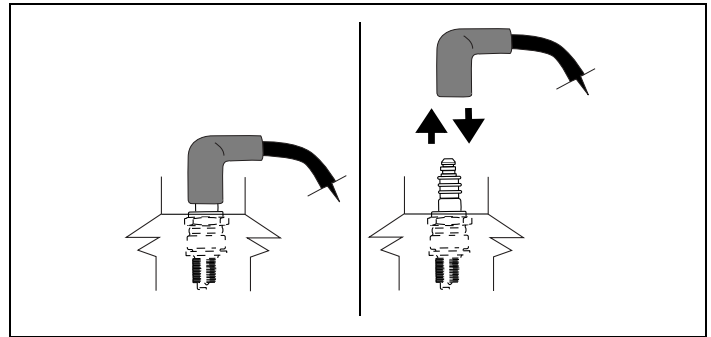

Figure 21. Disconnecting/Connecting Spark Plug

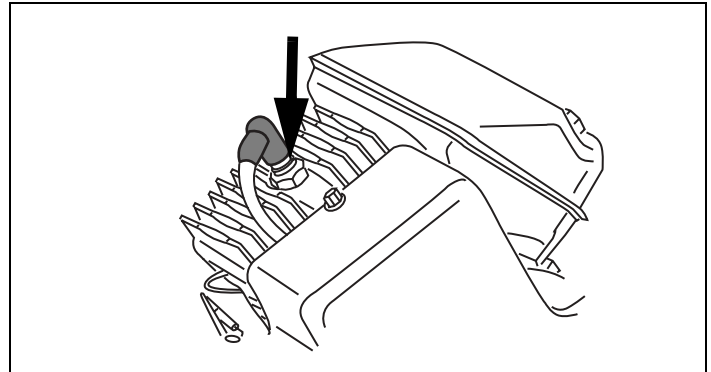

Figure 22. Typical Spark Plug Connection

## X. Preventing Forest, Brush and Grass Fires

Local, state and federal laws may require use of a spark arrester to prevent fires. For example, it is a violation of California Public Resources Code (section 4442) to use or operate engine on any forest-covered, brush-covered or unimproved grass-covered land unless engine is equipped with a spark arrester. Spark arrester must be maintained in effective working order by owner and/or operator.

To determine if your engine has a spark arrester, locate the muffler on your engine. For example, the muffler discharge will have a spark arrester cover that reads “Screen Type 36085”.

If your engine does NOT have a spark arrester, you may purchase one from your Authorized TecumsehPower Servicing Dealer. In some cases the muffler may need to be replaced to allow the spark arrester to be installed.









# CALIFORNIA & US EPA EMISSION CONTROL WARRANTY STATEMENT

The U. S. Environmental Protection Agency ("EPA"), the California Air Resources Board ("CARB") and TecumsehPower Company are pleased to explain the Federal and California Emission Control Systems Warranty on your new small off-road engine. In California, new 1995 and later small off-road engines must be designed, built and equipped to meet the State's stringent anti-smog standards. In other states, new 1997 and later model year engines must be designed, built and equipped, at the time of sale, to meet the U.S. EPA regulations for small non-road engines. TecumsehPower Company will warrant the emission control system on your small off-road engine for the periods of time listed below, provided there has been no abuse, neglect, unapproved modification, or improper maintenance of your small off-road engine.

Your emission control system may include parts such as the carburetor, air cleaner assembly, ignition system, exhaust system, crankcase breather assembly and, the evaporative control system. Also included may be the compression release system and other emission-related assemblies.

Where a warrantable condition exists, TecumsehPower Company will repair your small off-road engine at no cost to you for diagnosis, parts and labor.

## MANUFACTURER'S EMISSION CONTROL SYSTEM WARRANTY COVERAGE

Emission control systems on 1995 and later model year California small off-road engines are warranted for two years as hereinafter noted. In other states, 1997 and later model year engines are also warranted for two years. If, during such warranty period, any emission-related part on your engine is defective in materials or workmanship, the part will be repaired or replaced by TecumsehPower Company.

## OWNER'S WARRANTY RESPONSIBILITIES

As the small off-road engine owner, you are responsible for the performance of the required maintenance listed in your Operator's Manual, but TecumsehPower Company will not deny warranty solely due to the lack of receipts or for your failure to provide written evidence of the performance of all scheduled maintenance.

As the small off-road engine owner, you should, however, be aware that TecumsehPower Company may deny you warranty coverage if your small off-road engine or a part thereof has failed due to abuse, neglect, improper maintenance or unapproved modifications.

You are responsible for presenting your small off-road engine to a TecumsehPower Authorized Service Outlet

(any TecumsehPower Registered Service Dealer, TecumsehPower Authorized Service Distributor or TecumsehPower Central Warehouse Distributor) as soon as a problem exists. The warranty repairs should be completed in a reasonable amount of time, not to exceed 30 days.

Warranty service can be arranged by contacting either an Authorized TecumsehPower Servicing Dealer and/or TecumsehPower Company, c/o Service Manager, 900 North Street, Grafton, WI 53024-1499. Telephone 1-262-377-2700 [or in USA/Canada call 1-800-558-5402].

## IMPORTANT NOTE

This warranty statement explains your rights and obligations under the Emission Control System Warranty ("ECS Warranty") which is provided to you by TecumsehPower Company pursuant to California law. TecumsehPower Company also provides to original purchasers of new TecumsehPower engines the TecumsehPower Company Limited Warranties for New TecumsehPower Engines and Electronic Ignition Modules. The TecumsehPower Company Limited Warranties for New TecumsehPower Engines and Electronic Ignition Modules ("TecumsehPower Company Warranty") are located on the back cover of the Operator's Manual, enclosed with all new TecumsehPower engines. The ECS Warranty applies only to the emission control system of your new engine. To the extent that there is any conflict in terms between the ECS Warranty and the TecumsehPower Company Warranty, the ECS Warranty shall apply except in any circumstances in which the TecumsehPower Company Warranty may provide a longer warranty period. Both the ECS Warranty and the TecumsehPower Company Warranty describe important rights and obligations with respect to your new engine.

Warranty service can only be performed by a TecumsehPower Authorized Servicing Dealer. At the time of requesting warranty service, evidence must be presented of the date of sale to the original purchaser. The purchaser shall pay any charges for making service calls and/or for transporting the products to and from the place where the inspection and/or warranty work is performed. The purchaser shall be responsible for any damage or loss incurred in connection with the transportation of any engine or any part(s) thereof submitted for inspection and/or warranty work.

If you have any questions regarding your warranty rights and responsibilities, you should contact TecumsehPower Company at 1-262-377-2700 or in USA/Canada call 1-800-558-5402.

Revised February 2008

## IMPORTANT!

The Emission Regulations may be different for your country. The Emissions Control Warranty Statement is only applicable to engines with an emissions compliance statement and decal that references "Emissions Regulations".

## EMISSION CONTROL SYSTEM WARRANTY

Emission Control System Warranty ("ECS Warranty") for 1995 and later model year California small off-road engines (for other states, 1997 and later model year engines):

**A. APPLICABILITY:** This warranty shall apply to 1995 and later model year California small off-road engines (for other states, 1997 and later model year engines). The ECS Warranty Period shall begin on the date the new engine or equipment is delivered to its original, end-use purchaser, and shall continue for 24 consecutive months thereafter.

**B. GENERAL EMISSIONS WARRANTY COVERAGE:**

TecumsehPower Company warrants to the original, end-use purchaser of the new engine or equipment and to each subsequent purchaser that each of its small off-road engines is:

1. Designed, built and equipped so as to conform with all applicable regulations adopted by the Air Resources Board pursuant to its authority in Chapters 1 and 2, Part 5, Division 26 of the Health and Safety Code, and
2. Free from defects in materials and workmanship which, at any time during the ECS Warranty Period, will cause a warranted emissions-related part to fail to be identical in all material respects to the part as described in the engine manufacturer's application for certification.

**C. THE ECS WARRANTY ONLY PERTAINS TO EMISSION-RELATED PARTS ON YOUR ENGINE AS FOLLOWS:**

1. Any warranted, emissions-related parts which are not scheduled for replacement as required maintenance in the Operator's Manual shall be warranted for the ECS Warranty Period. If any such part fails during the ECS Warranty Period, it shall be repaired or replaced by TecumsehPower Company according to Subsection 4 below. Any such part repaired or replaced under the ECS Warranty shall be warranted for any remainder of the ECS Warranty Period.
2. Any warranted, emissions-related part which is scheduled only for regular inspection as specified in the Operator's Manual shall be warranted for the ECS Warranty Period. A statement in such written instructions to the effect of "repair or replace as necessary", shall not reduce the ECS Warranty Period. Any such part repaired or replaced under the ECS Warranty shall be warranted for the remainder of the ECS Warranty Period.
3. Any warranted, emissions-related part which is scheduled for replacement as required maintenance in the Operator's Manual, shall be warranted for the period of time prior to the first scheduled replacement point for that part. If the part fails prior to the first scheduled replacement, the part shall be repaired or replaced by TecumsehPower Company according to Subsection 4 below. Any such emissions-related part repaired or replaced under the ECS Warranty, shall be warranted for the remainder of the ECS Warranty Period prior to the first scheduled replacement point for such emissions-related part.
4. Repair or replacement of any warranted, emissions-related part under this ECS Warranty shall be performed at no charge to the owner at a TecumsehPower Authorized Service Outlet.

5. The owner shall not be charged for diagnostic labor which leads to the determination that a part covered by the ECS Warranty is in fact defective, provided that such diagnostic work is performed at a TecumsehPower Authorized Service Outlet.
6. TecumsehPower Company shall be liable for damages to other original engine components or approved modifications proximately caused by a failure under warranty of an emission-related part covered by the ECS Warranty.
7. Throughout the ECS Warranty Period, TecumsehPower Company shall maintain a supply of warranted emission-related parts sufficient to meet the expected demand for such emission-related parts.
8. Any TecumsehPower Company authorized and approved emission-related replacement part may be used in the performance of any ECS Warranty maintenance or repair and will be provided without charge to the owner. Such use shall not reduce TecumsehPower Company ECS Warranty obligations.
9. Unapproved add-on or modified parts may not be used to modify or repair a TecumsehPower engine. Such use voids this ECS Warranty and shall be sufficient grounds for disallowing an ECS Warranty claim. TecumsehPower Company shall not be liable hereunder for failures of any warranted parts of a TecumsehPower engine caused by the use of such an unapproved add-on or modified part.

**EMISSION-RELATED PARTS INCLUDE THE FOLLOWING:**

1. Carburetor Assembly including internal components:
  - a) Carburetor gaskets
  - b) Intake pipe
2. Air Cleaner Assembly including components:
  - a) Air filter element
3. Ignition System including components:
  - a) Spark plug
  - b) Ignition module
  - c) Flywheel assembly
4. Exhaust System including components:
  - a) Catalytic muffler (*if so equipped*)
  - b) Muffler gasket (*if so equipped*)
  - c) Exhaust manifold (*if so equipped*)
5. Crankcase Breather Assembly including components:
  - a) Breather connection tube
6. Evaporative Control System including components:
  - a) Fuel line(s)
  - b) Fuel filter
  - c) Canister (*if so equipped*)
  - d) Fuel tank (*if so equipped*)
  - e) Fuel fill cap (*if so equipped*)

Revised February 2008

### IMPORTANT!

The Emission Regulations may be different for your country. The Emissions Control Warranty Statement is only applicable to engines with an emissions compliance statement and decal that references "Emissions Regulations".

## XII. Warranty Information

### LIMITED WARRANTY FOR NEW TECUMSEHPower ENGINES AND ELECTRONIC IGNITION MODULES

For the time period shown below from the date of purchase and subject to the exceptions and limitations described herein, TecumsehPower Company will, at its option as the exclusive remedy, either repair or replace for the original purchaser, free of charge, any part of any new TecumsehPower engine which is found, upon examination by any Authorized TecumsehPower Servicing Outlet or by TecumsehPower's Service Division, to be **DEFECTIVE IN MATERIAL AND/OR WORKMANSHIP**. This Limited Warranty **DOES NOT COVER** (i) any TecumsehPower engine or part(s) thereof used to power any vehicle in competitive racing and/or used on any commercial or rental track, or (ii) defects or damage caused by alterations or modifications of new TecumsehPower engines or parts or by normal wear, accidents, improper maintenance, improper use or abuse of the product, or failure to follow the instructions contained in an Instruction Manual for the operation of the new TecumsehPower engine or part. The cost of normal maintenance or replacement of service items which are not defective shall be paid for by the original purchaser. At the time warranty service is requested, evidence must be presented of the date of purchase by the original purchaser. Any charge for making service calls and/or for transporting any engine or part(s) thereof to and from the place where the inspection and/or warranty work is performed is payable solely by the purchaser. The purchaser is responsible for any damage or loss incurred in connection with the transportation of any engine or part(s) thereof submitted for inspection and/or warranty work. **WARRANTY SERVICE CAN ONLY BE PERFORMED BY A TECUMSEHPower AUTHORIZED SERVICE OUTLET.** Warranty service can be arranged by contacting a TecumsehPower Authorized Service Outlet (any TecumsehPower Registered Service Dealer, TecumsehPower Authorized Service Distributor, or TecumsehPower Central Warehouse Distributor) or by contacting TecumsehPower Company c/o Service Manager, 900 North Street, Grafton, Wisconsin USA 53024-1499.

Warranty Category <sup>(6)</sup>	"CONSUMER USE" <sup>(4)</sup>		"COMMERCIAL USE" <sup>(5)</sup>	
	Within U.S.A. and Canada	Outside U.S.A. and Canada	Within U.S.A. and Canada	Outside U.S.A. and Canada
(A)	90 Day	90 Day <sup>(1)</sup>	No Warranty	No Warranty
(B)	1 Year	1 Year <sup>(1)</sup>	1 Year	1 Year
(C)	2 Years	1 Year <sup>(1)</sup>	1 Year	1 Year
(D)	2 Years	2 Years <sup>(2)</sup>	1 Year	1 Year
(E)	2 Years	2 Years	1 Year	1 Year
(H)	2 'n 10 <sup>(3)</sup>	2 'n 10 <sup>(3)</sup>	1 Year	1 Year
(K)	2 'n 10 <sup>(3)</sup>	2 'n 10 <sup>(3)</sup>	2 'n 10 <sup>(3)</sup>	1 Year
(M) <sup>(7)</sup>	3 Years	3 Years	1 Year	1 Year

- (1) 2 years for Member States of the European Union. Consumers may have additional legal rights not affected by the terms of this warranty pursuant to EU Directive 1999/44/EC and the national legislation of certain Member States of the European Union.
- (2) 1 year for Australian/New Zealand for rotary mower engines.
- (3) 2 years on engine and 10 years (the first 5 years covering parts and labor only; the second 5 years covering parts only) on electronic ignition.
- (4) For purposes of this warranty policy, "consumer use" shall mean consumer's personal, residential, household use by the original retail purchaser.
- (5) For purposes of this warranty policy, "commercial use" shall mean all other uses, including use for commercial, income producing, or rental purposes.
- (6) The engine warranty category of your engine can be determined by review of the engine model number on the "Important Engine Information" decal. One letter in the engine model number will be surrounded by parenthesis (A), (B), (C), (D), (E), (H) (K) or (M) and that letter is your engine warranty category designation.
- (7) Qualification for three (3) year consumer use warranty under engine warranty category (M) may be determined by notation of an (M) designation on the "Important Engine Information" decal located on the engine housing or an addendum decal affixed adjacent thereto.

THIS EXPRESS WARRANTY IS SUPPLEMENTED BY THE TECUMSEHPower CALIFORNIA EMISSION CONTROL WARRANTY STATEMENT, if any.

**THIS EXPRESS WARRANTY IS IN LIEU OF ALL OTHER EXPRESS WARRANTIES.** Neither TecumsehPower Company nor any of its affiliates makes any warranties, representations, or promises, written or oral, as to the quality of the engine or any of its parts, other than as set forth herein. **ANY IMPLIED WARRANTY OF MARKETABILITY, MERCHANTABILITY, OR FITNESS FOR A PARTICULAR PURPOSE, TO THE EXTENT THAT EITHER MAY APPLY TO ANY TECUMSEHPower ENGINE OR PART(S) THEREOF, SHALL BE LIMITED IN DURATION TO THE PERIODS OF THE EXPRESS WARRANTIES SHOWN IN THE WARRANTY PERIOD CHART ABOVE AND TO THE EXTENT PERMITTED BY LAW ANY AND ALL IMPLIED WARRANTIES ARE EXCLUDED. IN NO EVENT WILL TECUMSEHPower COMPANY BE LIABLE FOR ANY INDIRECT, INCIDENTAL, CONSEQUENTIAL OR SPECIAL DAMAGES AND/OR EXPENSES, INCLUDING, BUT NOT LIMITED TO, ANY LOSS OF TIME, INCONVENIENCE, LOSS OF UNIT USE OR ANY COST OR EXPENSE OF SUBSTITUTE UNITS DURING PERIODS OF MALFUNCTION OR NON-USE.** Some states do not allow limitations on how long an implied warranty lasts or the exclusion or limitation of incidental or consequential damages, so the above limitation(s) or exclusion(s) may not apply to you. This Limited Warranty gives you specific legal rights and you may also have other legal rights which vary from state-to-state.

TecumsehPower Company neither assumes nor authorizes any other person, natural or corporate, to assume for TecumsehPower Company any other obligations or liabilities in connection with or with respect to any TecumsehPower product or parts. The seller or dealer of a TecumsehPower product or part has no authority, whatsoever, to make any representations or promises on behalf of TecumsehPower Company or to modify the terms or limitations of TecumsehPower's warranty in any way.

Revised February 2008

#### **WARNING** CALIFORNIA PROPOSITION 65

The engine exhaust from this product contains chemicals known to the State of California to cause cancer, birth defects or other reproductive harm.



TecumsehPower Company • Grafton, Wisconsin 53024-1499 • USA  
Telephone: 1-800-558-5402

Visit us at: [www.TecumsehPower.com](http://www.TecumsehPower.com)

**181-807-14**  
**(English) 6/01/08**



## Free Manuals Download Website

<http://myh66.com>

<http://usermanuals.us>

<http://www.somanuals.com>

<http://www.4manuals.cc>

<http://www.manual-lib.com>

<http://www.404manual.com>

<http://www.luxmanual.com>

<http://aubethermostatmanual.com>

Golf course search by state

<http://golfingnear.com>

Email search by domain

<http://emailbydomain.com>

Auto manuals search

<http://auto.somanuals.com>

TV manuals search

<http://tv.somanuals.com>